

芯伯乐®
X I N B O L E

Product Specification

XBLW OPA333.2333

High-Precision, Rail-to-Rail I/O Operational Amplifier

WEB | www.xinboleic.com



Description

The OPA333, OPA2333 and are high-precision, low-quiescent current amplifier which can offer high input impedance and rail-to-rail input and output. The amplifier uses auto-zeroing techniques to provide low offset voltage(2 μ V type) and near zero-drift over time and temperature. These devices are optimized for low-voltage, single-supply operation.

The OPAX333 family provides excellent CMRR with no crossover associated with traditional complementary input levels. The design achieves excellent performance over the drive Analog-to-digital converter (ADC) process without reducing Differential nonlinearity.

The OPA333 (single) is available in SOT23-5 and SOP-8.

The OPA2333 (dual) is available in SOP-8 and MSOP-8.

Feature:

- Rail-to-Rail Input and Output
- Zero-Drift: 0.05 μ V/ $^{\circ}$ C
- Low Noise: 48nV/ \sqrt Hz
0.1Hz to 10Hz Noise: 0.8 μ VPP
- Gain bandwidth: 0.4MHz
- Quiescent current: 18 μ A(Typ.)
- Supply Range: 1.8V-5.5V
- Low Offset Voltage: 2 μ V(Typ.)

Applications

- Wearables
- Smartphones
- Electronic Scales
- Circuit Breakers
- Medical Instrumentation
- Battery-Powered Instruments
- Handheld Test Equipment
- Resistance Temperature Detectors

Ordering Information

Product Model	Package Type	Marking	Packing	Packing Qty
XBLW OPA333AIDBVR	SOT23-5	333A	Tape	3000Pcs/Reel
XBLW OPA333AIDR	SOP-8	O333A	Tape	2500Pcs/Reel
XBLW OPA2333AIDR	SOP-8	O2333A	Tape	2500Pcs/Reel
XBLW OPA2333AIDGKR	MSOP-8	2333A	Tape	3000Pcs/Reel

Pin Configurations

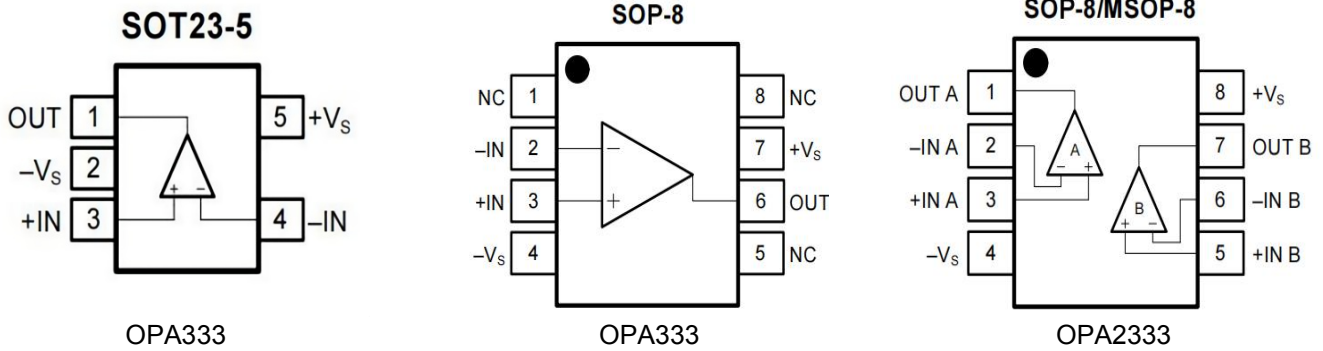

Pin Description

Symbol	Description
-INA, -INB	Inverting Input of the Amplifier. The Voltage range can go from (V_s^-) to (V_s^+).
+INA, +INB	Non-Inverting Input of Amplifier. This pin has the same voltage range as -IN.
$+V_s$	Positive Power Supply. The voltage is from 1.8V to 5.5V ($\pm 0.9V$ to $\pm 2.75V$).
$-V_s$	Negative Power Supply. It is normally tied to ground.
OUTA, OUTB	Amplifier Output.
N/C	No Connection.

Absolute Maximum Ratings (TA=25°C)

Parameter	Description	Value	Units
Supply Voltage		$\pm 3, +6$ (Single)	V
Voltage	Input Terminal	$V_s^- - 0.3$ to $V_s^+ + 0.3$	V
Differential Voltage		± 5	V
Temperature	Operating ⁽²⁾ , T_A	-55 to +150	°C
	Junction, T_J	150	°C
	Storage, T_{STG}	-65 to +150	°C
HBM	Electrostatic Discharge Voltage	8	kV

Note:

- Stresses beyond those listed under Absolute Maximum Ratings may cause permanent damage to the device. These are stress ratings only, which do not imply functional operation of the device at these or any other conditions beyond those indicated under Recommended Operating Conditions. Exposure to absolute-maximum-rated conditions for extended periods may affect device reliability.
- Provided device does not exceed maximum junction temperature (T_J) at any time.

Electrical Characteristics

$V_S=+5.0V, T_A=+25^{\circ}C, V_{CM}=V_S/2, V_O=V_S/2, R_L=10k\Omega$ connected to $V_S/2$, unless otherwise noted.

Symbol	Parameter	Conditions	Min.	Typ.	Max.	Unit
INPUT CHARACTERISTICS						
V_{OS}	Input offset voltage			2	15	μV
V_{OSTC}	Offset voltage drif	$T_A=-40^{\circ}C$ to $+125^{\circ}C$		0.05		$\mu V/^{\circ}C$
I_B	Input bias current	$V_{CM}=V_S/2$		± 100		PA
I_{OS}	Input offset current			± 100		PA
V_{CM}	Common-mode voltage range	$T_A=-40^{\circ}C$ to $+125^{\circ}C$	V_{S-}		V_{S+}	V
CMRR	Common-mode rejection ratio	$V_{S-} < V_{CM} < V_{S+}$	90	110		dB
		$T_A=-40^{\circ}C$ to $+125^{\circ}C$	85			
A_{VOL}	Open-loop voltage gain	$V_{S-}+0.3V < V_O < V_{S+}-0.3V$	105	135		
		$T_A=-40^{\circ}C$ to $+125^{\circ}C$	100			
OUTPUT CHARACTERISTICS						
V_{OH}	High output voltage swing	$R_L=10K\Omega$	$(V_{S+})-12$	$(V_{S+})-4$		mV
		$T_A=-40^{\circ}C$ to $+125^{\circ}C$	$(V_{S+})-18$			
V_{OL}	Low output voltage swing	$R_L=10K\Omega$		$(V_{S-})+4$	$(V_{S-})+12$	mV
		$T_A=-40^{\circ}C$ to $+125^{\circ}C$			$(V_{S-})+18$	
I_{SC}	Short-circuit current	Source current	55	65		mA
		$T_A=-40^{\circ}C$ to $+125^{\circ}C$	50			mA
		Sink current	48	55		mA
		$T_A=-40^{\circ}C$ to $+125^{\circ}C$	45			mA
POWERSUPPLY						
PSRR	Power supply rejection ratio	$V_S=1.8V$ to $5.5V$	90	110		dB
		$T_A=-40^{\circ}C$ to $+125^{\circ}C$	80			
I_Q	Quiescent current (per amplifier)	$T_A=-40^{\circ}C$ to $+125^{\circ}C$		20	28	μA
					35	
NOISE PERFORMANCE						
e_n	Input voltage noise density	$f=0.1Hz$ to $10Hz$		800		nVpp
		$f=1KHz$		48		nV/ \sqrt{Hz}
DYNAMIC PERFORMANCE						
GBW	Gain bandwidth productt			0.4		MHz
SR	Slew rate	$G=+1$		0.1		V/ μs
t_{OR}	Overload recovery time	$G=-10$		20		μs

Electrical Characteristics

$V_S=+2.7V, T_A=+25^{\circ}C, V_O=V_S/2, R_L=10k\Omega$ connected to $V_S/2$, unless otherwise noted.

Symbol	Parameter	Conditions	Min.	Typ.	Max.	Unit
INPUT CHARACTERISTICS						
V_{OS}	Input offset voltage			4	20	μV
V_{OSTC}	Offset voltage drift	$T_A=-40^{\circ}C$ to $+125^{\circ}C$		0.05		$\mu V/^{\circ}C$
I_B	Input bias current	$V_{CM}=V_S/2$		± 100		PA
I_{OS}	Input offset current			± 100		PA
V_{CM}	Common-mode voltage range	$T_A=-40^{\circ}C$ to $+125^{\circ}C$	V_{S-}		V_{S+}	V
CMRR	Common-mode rejection ratio	$V_{S-} < V_{CM} < V_{S+}$	90	110		dB
		$T_A=-40^{\circ}C$ to $+125^{\circ}C$	80	100		
A_{VOL}	Open-loop voltage gain	$V_{S+}+0.3V < V_O < V_{S+}-0.3V$	105	135		
		$T_A=-40^{\circ}C$ to $+125^{\circ}C$	95			
OUTPUT CHARACTERISTICS						
V_{OH}	High output voltage swing	$R_L=10K\Omega$	$(V_{S+})-12$	$(V_{S+})-3$		mV
		$T_A=-40^{\circ}C$ to $+125^{\circ}C$	$(V_{S+})-18$			
V_{OL}	Low output voltage swing	$R_L=10K\Omega$		$(V_{S-})+3$	$(V_{S-})+12$	mV
		$T_A=-40^{\circ}C$ to $+125^{\circ}C$			$(V_{S-})+18$	
I_{SC}	Short-circuit current	Source current	17	24		mA
		$T_A=-40^{\circ}C$ to $+125^{\circ}C$	14			mA
		Sink current	15	20		mA
		$T_A=-40^{\circ}C$ to $+125^{\circ}C$	12			mA
POWER SUPPLY						
PSRR	Power supply rejection ratio	$V_S=1.8V$ to $5.5V$	90	110		dB
		$T_A=-40^{\circ}C$ to $+125^{\circ}C$	80			
I_Q	Quiescent current (per amplifier)	$T_A=-40^{\circ}C$ to $+125^{\circ}C$		18	25	μA
					35	
NOISE PERFORMANCE						
e_n	Input voltage noise density	$f=0.1Hz$ to $10Hz$		800		nVpp
		$f=1KHz$		48		nV/\sqrt{Hz}
DYNAMIC PERFORMANCE						
GBW	Gain bandwidth product	$f=1kHz$		0.4		MHz
SR	Slew rate	$G=+1$		0.1		$V/\mu s$
t_{OR}	Overload recovery time	$G=-10$		20		μs

Typical Performance Characteristics

$V_S=+5V$, $T_A=+25^\circ C$, $V_{CM}=V_S/2$, $R_L=10k\Omega$ connected to $V/2$, unless otherwise noted.

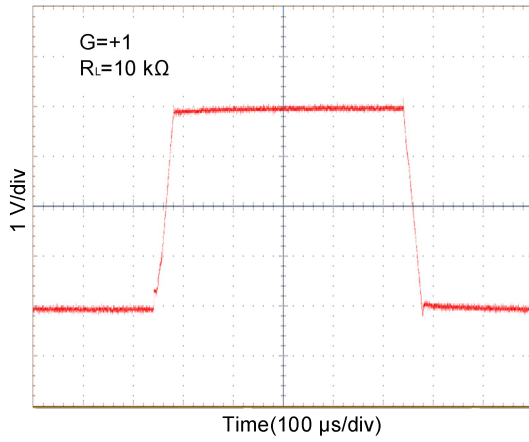

Figure 2 LARGE-SIGNAL STEP RESPONSE at +5V

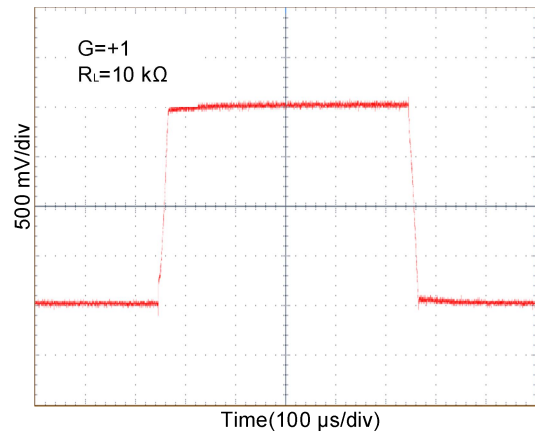

Figure 3 LARGE-SIGNAL STEP RESPONSE at +2.7V

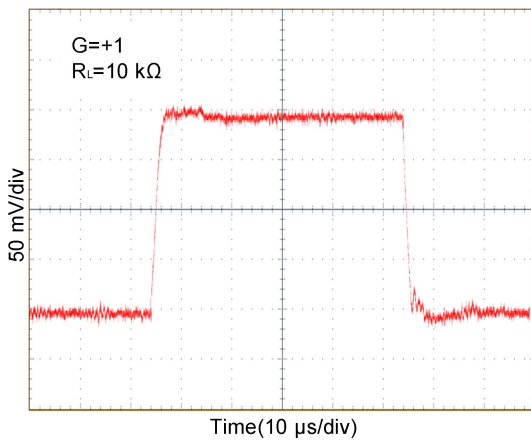

Figure 4 SMALL-SIGNAL STEP RESPONSE at +5V

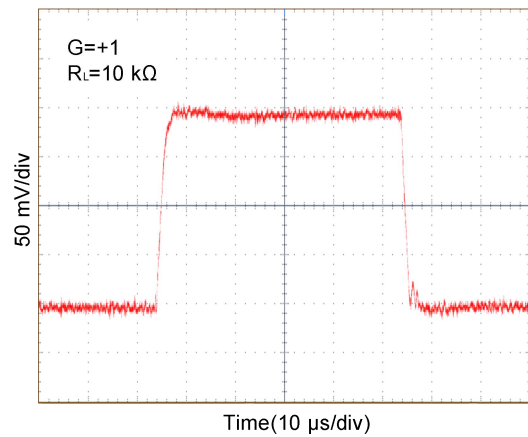

Figure 5 SMALL-SIGNAL STEP RESPONSE at +2.7V

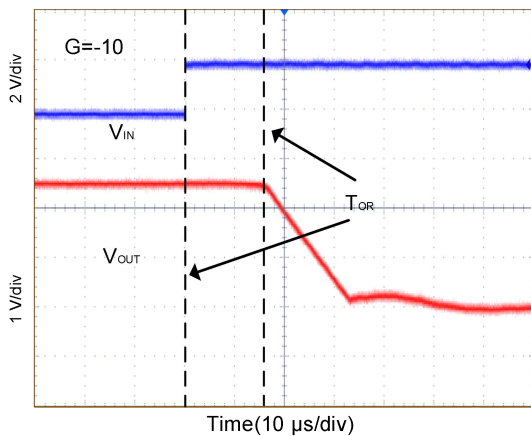

Figure 6 POSITIVE OVERLOAD RECOVERY

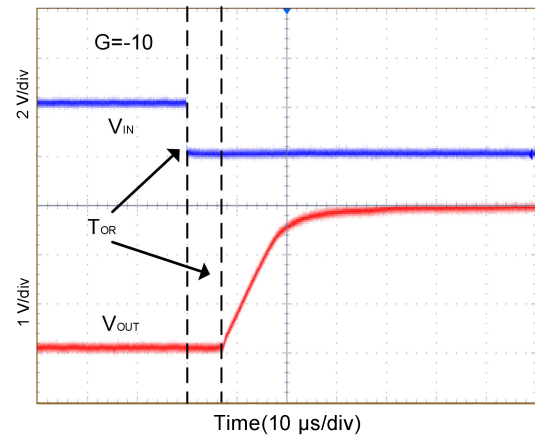

Figure 7 NEGATIVE OVERLOAD RECOVERY

Typical Performance Characteristics

$V_S=+5V$ $T_A=+25^\circ C$ $V_{CM}=V_S/2$ $R_L=10k\Omega$ connected to $V/2$ unless otherwise noted

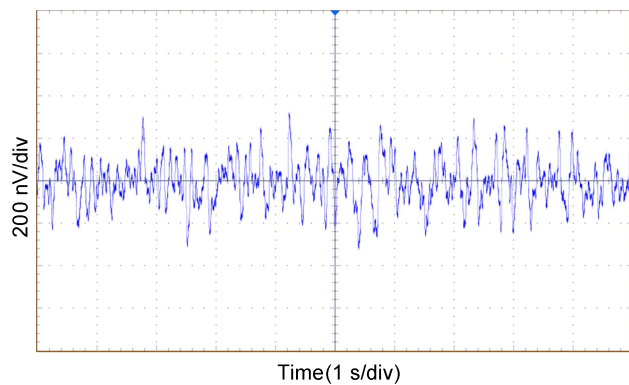

Figure 8 0.1Hz to 10Hz noise

Application Notes

1. Operation Characteristics

The OPAX333 is specified for operation from 1.8V to 5.5 V ($\pm 0.9V$ to $\pm 2.75 V$). Many specifications apply from $-40^{\circ}C$ to $+125^{\circ}C$. Parameters that can exhibit significant variance with regard to operating voltage or temperature are presented in *Typical Characteristics*.

2. Capacitive Load and Stability

The unity-gain follower (buffer) is the most sensitive configuration to capacitive loading. Direct capacitive loading reduces the phase margin of amplifiers and this results in ringing or even oscillation. Applications that require greater capacitive drive capability should use an isolation resistor between the output and the capacitive load like the circuit in Figure 9. The isolation resistor R_{ISO} and the load capacitor C_L form a zero to increase stability. The bigger the R_{ISO} resistor value, the more stable V_{out} will be. Note that this method results in a loss of gain accuracy because R_{ISO} forms a voltage divider with the R_L .

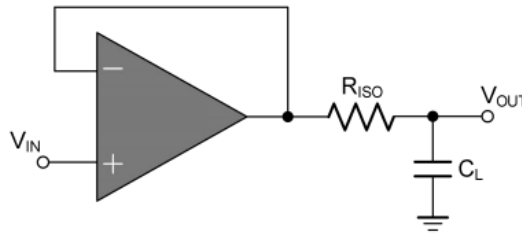

Figure 9. Indirectly Driving Heavy Capacitive Load

An improvement circuit is shown in Figure 10. It provides DC accuracy as well as AC stability. The R_F provides the DC accuracy by connecting the inverting signal with the output.

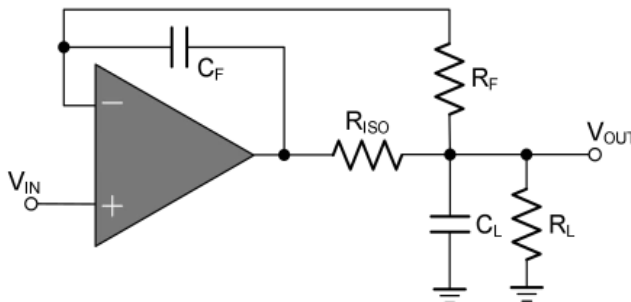

Figure 10. Indirectly Driving Capacitive Load with DC Accuracy

3. Input Bias Current Clock Feedthrough

The OPAX333 use switching on the inputs to correct for the intrinsic offset and drift of the amplifier. Charge injection from the integrated switches on the inputs can introduce very short transients in the input bias current of the amplifier. The extremely short duration of these pulses prevents the device from being amplified. However, the devices may be coupled to the output of the amplifier through the feedback network. The most effective method to prevent transients in the input bias current from producing additional noise at the amplifier output is to use a low-pass filter such as an RC network.

4. Layout Guidelines

For best operational performance of the device, use good printed circuit board (PCB) layout practices, including:

A. Place the external components as close to the device as possible. This configuration prevents parasitic errors (such as the Seebeck effect) from occurring.

B. To reduce parasitic coupling, run the input traces as far away from the supply lines and digital signal as possible.

C. Low-ESR, 0.1- μ F ceramic bypass capacitors must be connected between each supply pin and ground, placed as close to the device as possible. A single bypass capacitor from V+ to ground is applicable to single supply applications.

D. Consider a driven, low-impedance guard ring around the critical traces. A guard ring can significantly reduce leakage currents from nearby traces that are at different potentials.

5. Low-side Current Monitor

Figure 11 shows the OPAX333 configured in a low-side current-sensing application.

The load current (I_{LOAD}) creates a voltage drop across the shunt resistor (R_{SHUNT}). This voltage is amplified by the OPAX333.

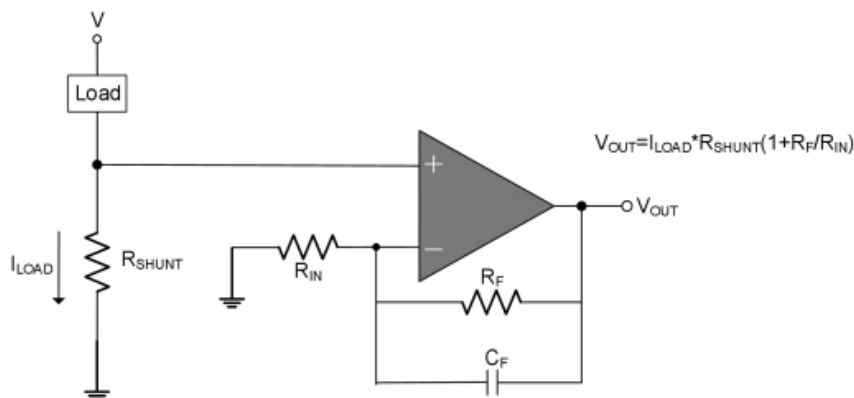

Figure11.Low-SideCurrentMonitor

6. Bridge Amplifier

Figure 12 shows the basic configuration for a bridge amplifier.

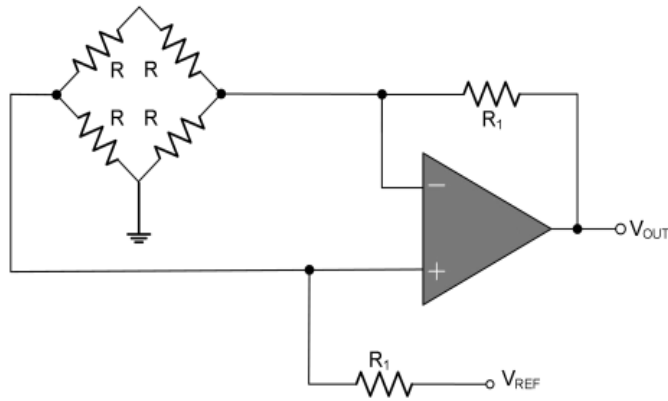

Figure 12. Bridge Amplifier

7. Programmable Power Supply

Figure 13 shows the OPAX333 configured as a precision programmable power supply using DAC and power amplifier. The OPAX333 in the front-end provides precision and low drift across a wide range of inputs and conditions.

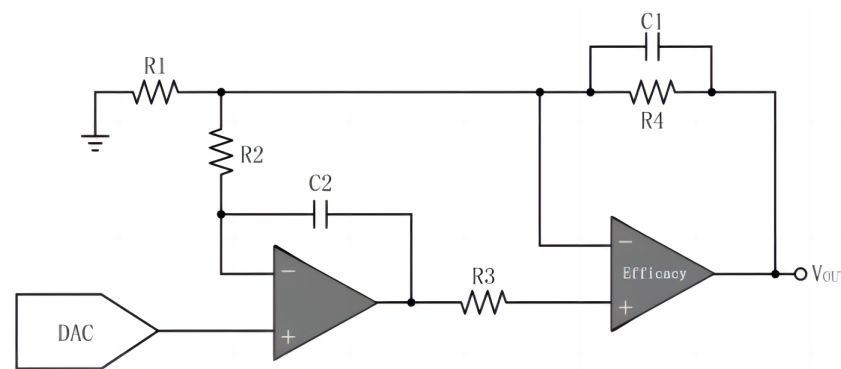
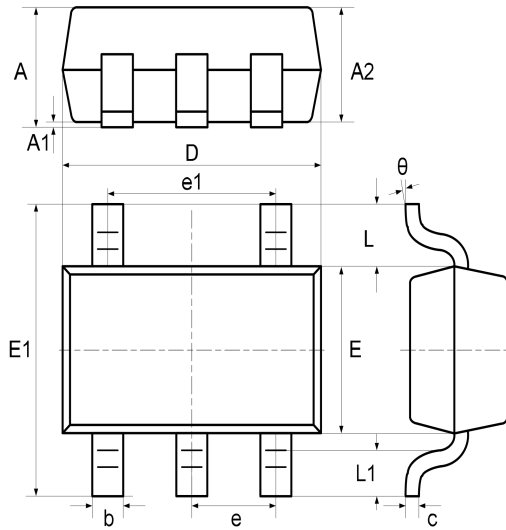

Figure13.ProgrammablePowerSupply

Package Information

SOT23-5



Symbol	Dimensions In Millimeters		Dimensions In Inches	
	Min	Max	Min	Max
A	1.040	1.350	0.042	0.055
A1	0.040	0.150	0.002	0.006
A2	1.000	1.200	0.041	0.049
b	0.380	0.480	0.015	0.020
c	0.110	0.210	0.004	0.009
D	2.720	3.120	0.111	0.127
E	1.400	1.800	0.057	0.073
E1	2.600	3.000	0.106	0.122
e	0.950 typ.		0.037 typ.	
e1	1.900 typ.		0.078 typ.	
L	0.700 ref.		0.028 ref.	
L1	0.300	0.600	0.012	0.024
theta	0°	8°	0°	8°

MSOP-8

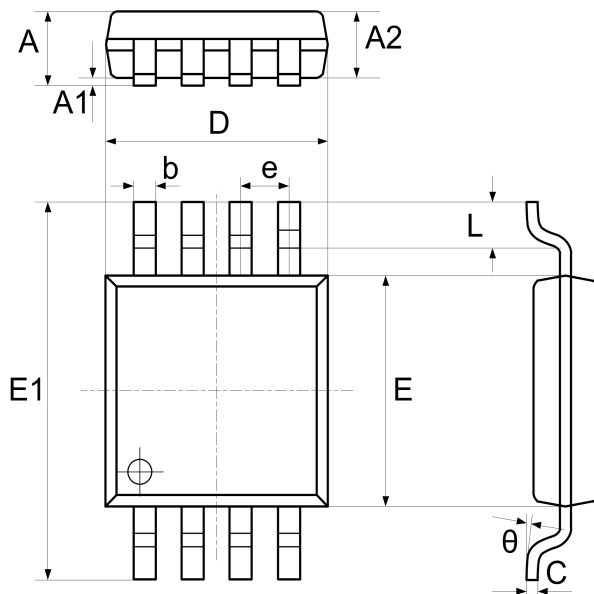

Symbol	Dimensions In Millimeters		Dimensions In Inches	
	Min	Max	Min	Max
A	0.800	1.100	0.033	0.045
A1	0.050	0.150	0.002	0.006
A2	0.750	0.950	0.031	0.039
b	0.290	0.380	0.012	0.016
C	0.150	0.200	0.006	0.008
D	2.900	3.100	0.118	0.127
E	2.900	3.100	0.118	0.127
E1	4.700	5.100	0.192	0.208
e	0.650 typ.		0.026 typ.	
L	0.400	0.700	0.016	0.029
theta	0°	8°	0°	8°

SOP-8

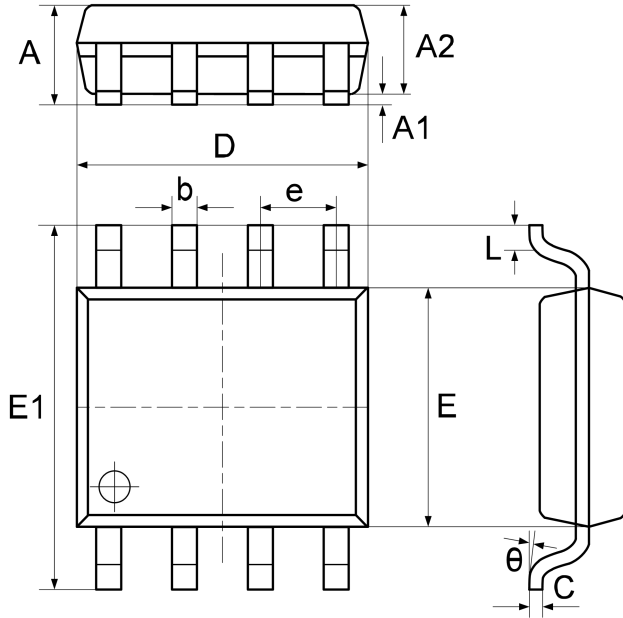

Symbol	Dimensions In Millimeters		Dimensions In Inches	
	Min	Max	Min	Max
A	1.370	1.670	0.056	0.068
A1	0.070	0.170	0.003	0.007
A2	1.300	1.500	0.053	0.061
b	0.306	0.506	0.013	0.021
C	0.203 typ.		0.008 typ.	
D	4.700	5.100	0.192	0.208
E	3.820	4.020	0.156	0.164
E1	5.800	6.200	0.237	0.253
e	1.270 typ.		0.050 typ.	
L	0.450	0.750	0.018	0.306
θ	0°	8°	0°	8°

Statement:

- XBLW reserves the right to modify the product manual without prior notice! Before placing an order, customers need to confirm whether the obtained information is the latest version and verify the completeness of the relevant information.
- Any semi-guide product is subject to failure or malfunction under specified conditions. It is the buyer's responsibility to comply with safety standards when using XBLW products for system design and whole machine manufacturing. And take the appropriate safety measures to avoid the potential in the risk of loss of personal injury or loss of property situation!
- XBLW product has not been licensed for life support, military and aerospace applications, and therefore XBLW is not responsible for any consequences arising from its use in these areas.
- If any or all XBLW products (including technical data, services) described or contained in this document are subject to any applicable local export control laws and regulations, they may not be exported without an export license from the relevant authorities in accordance with such laws.
- The specifications of any and all XBLW products described or contained in this document specify the performance, characteristics, and functionality of said products in their standalone state, but do not guarantee the performance, characteristics, and functionality of said products installed in Customer's products or equipment. In order to verify symptoms and conditions that cannot be evaluated in a standalone device, the Customer should ultimately evaluate and test the device installed in the Customer's product device.
- XBLW documentation is only allowed to be copied without any alteration of the content and with the relevant authorization. XBLW assumes no responsibility or liability for altered documents.
- XBLW is committed to becoming the preferred semiconductor brand for customers, and XBLW will strive to provide customers with better performance and better quality products.

X-ON Electronics

Largest Supplier of Electrical and Electronic Components

Click to view similar products for [Precision Amplifiers](#) category:

Click to view products by [XBLW](#) manufacturer:

Other Similar products are found below :

[ADA4692-4ARUZ-RL](#) [RS8654XP](#) [LTC6362IDD#TRPBF](#) [AD8627AKSZ-REEL](#) [TLC27L9CDR](#) [OPA2140AIDRGR](#) [OPA4186DR](#)
[MCP6V54-E/SL](#) [OP07CP\(LX\)](#) [CBM8606AWS8](#) [MCP6V91UT-E/LTY](#) [LTC2057HS8#TRPBF](#) [AD8662ARZ-REEL](#) [OPA277UA\(UMW\)](#)
[HG8552CMM/TR](#) [TSZ122IYDT\(UMW\)](#) [TSZ122IDT\(UMW\)](#) [LTC8552-TP](#) [OPA2330AIDR-TP](#) [TPV2376S8](#) [OPA2336UA-TP](#)
[OPA2376AIDR-TP](#) [TPSGM8552XS8G](#) [AD8538ARZ\(UMW\)](#) [OPA2333AIDR-TP](#) [OPA2317IDR-TP](#) [OPA2330AIDR\(UMW\)](#)
[OPA2333AIDR\(XBLW\)](#) [AD8552ARZ\(XBLW\)](#) [OP177FN](#) [AD8554ARZ-MS](#) [OP2177ARZ\(UMW\)](#) [AD8630ARZ-MS](#) [SL8582XS8](#)
[LTC2051IMS8#TRPBF](#) [ADA4610-2ARZ-RL](#) [LTC2054HVCS5#TRPBF](#) [CI823B](#) [ADA4610-1BRZ-R7](#) [OPA4189IPWR](#) [LT6233IS6-10#TRPBF](#) [OPA2328DR](#) [MCP60721UT-E/LTY](#) [MCP60721T-E/OT](#) [TLC27L7CP](#) [LT1014DDWR](#) [TLV4376IPWR](#) [5962-9088106Q2A](#)
[LMP2231AMFE/NOPB](#) [LMP7715MFE/NOPB](#)