

芯伯乐®
X I N B O L E

Product Specification

XBLW LM2577

Step-Up Voltage Regulator

WEB | www.xinboleic.com



Description

The LM2577 is a monolithic integrated circuit that provide all of the power and control functions for step-up (boost), flyback, and forward converter switching regulators. The device is available in three different output voltage versions: 12V, 15V, and adjustable. Requiring a minimum number of external components, these regulators are cost effective, and simple to use. Listed in this data sheet are a family of standard inductors and flyback transformers designed to work with these switching regulators. Included on the chip is a 3.0A NPN switch and its associated protection circuitry, consisting of current and thermal limiting, and undervoltage lockout. Other features include a 52 kHz fixed-frequency oscillator that requires no external components, a soft start mode to reduce in-rush current during start-up, and current mode control for improved rejection of input voltage and output load transients.

Feature:

- Requires few external components
- NPN output switches 3.0A, can stand off 65V
- Wide input voltage range: 3.5V to 40V
- Current-mode operation for improved transient response, line regulation, and current limit
- 52 kHz internal oscillator
- Soft-start function reduces in-rush current during start-up
- Output switch protected by current limit, under-voltage lockout, and thermal shutdown

Applications

- Simple boost regulator
- Flyback and forward regulators
- Multiple-output regulator

Ordering Information

Product Model	Package Type	Marking	Packing	Packing Qty
XBLW LM2577S-12	TO-263-5	LM2577S-12	Tape	800Pcs/Reel
XBLW LM2577T-12	TO-220-5	LM2577T-12	Tube	1000Pcs/Box
XBLW LM2577S-15	TO-263-5	LM2577S-15	Tape	800Pcs/Reel
XBLW LM2577T-15	TO-220-5	LM2577T-15	Tube	1000Pcs/Box
XBLW LM2577S-ADJ	TO-263-5	LM2577S-ADJ	Tape	800Pcs/Reel
XBLW LM2577T-ADJ	TO-220-5	LM2577T-ADJ	Tube	1000Pcs/Box

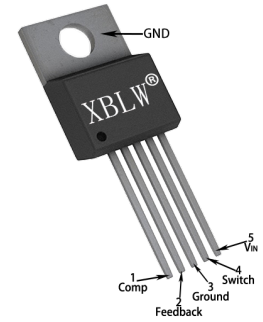

TO-220-5

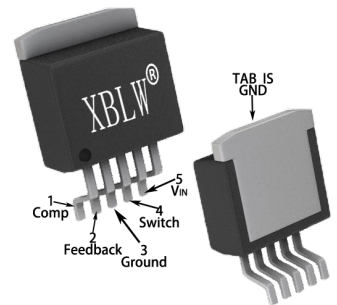

TO-263-5

Absolute Maximum Ratings

If Military/Aerospace specified devices are required, please contact the National Semiconductor Sales Office/Distributors for availability and specifications.

Characteristic	Limit	Unit
Supply voltage	45	V
Output switch voltage	65	V
Output switch current *2	6.0	A
Power dissipation	Internally limited	
Storage temperature range	-65~+150	°C
Lead temperature (soldering, 10 sec.)	260	°C
Maximum junction temperature	150	°C
Minimum ESD rating (C= 100pF, R= 1.5kΩ)	2	kV

Note 1: Absolute Maximum Ratings indicate limits beyond which damage to the device may occur. Operating ratings indicate conditions the device is intended to be functional, but device parameter specifications may not be guaranteed under these conditions. For guaranteed specifications and test conditions, see the Electrical Characteristics.

Note 2: Due to timing considerations of the LM2577 current limit circuit, output current cannot be internally limited when the LM2577 is used as a step-up regulator. To prevent damage to the switch, its current must be externally limited to 6.0A. However, output current is internally limited when the LM2577 is used as a flyback or forward converter regulator in accordance to the Application Hints.

Recommended Operating Rating

Characteristic	Limit	Unit
Supply voltage	3.5~40	V
Output switch voltage	0~60	V
Output switch current	≤3.0	A
Junction temperature range	-40~+125	°C

Electrical Characteristics: (Specifications with standard type face are for $T_J=25^{\circ}\text{C}$, and those in bold type face apply over full Operating Temperature Range. Unless otherwise specified, $V_{IN} = 5\text{V}$, and $I_{SWITCH} = 0$.)

LM2577-12

Characteristic	Symbol	Test conditions	Min. *3	Typ.	Max *3	Unit
System Parameters circuit of figure 1 *4						
Output voltage	V_{OUT}	$V_{IN}=5\text{V to }10\text{V}$ $I_{LOAD}=100\text{mA to }800\text{mA}$ *5	11.6/ 11.4	12	12.4/ 12.6	V
Line regulation	$\frac{\Delta V_{OUT}}{\Delta V_{IN}}$	$V_{IN}=3.5\text{V to }10\text{V}$ $I_{LOAD}=300\text{mA}$		20	50/ 100	mV
Load regulation	$\frac{\Delta V_{OUT}}{\Delta I_{LOAD}}$	$V_{IN}=5\text{V}$, $I_{LOAD}=100\text{mA to }800\text{mA}$		20	50/ 100	mV
Efficiency	η	$V_{IN}=5\text{V}, I_{LOAD}=800\text{mA}$		80		%
Device Parameters						
Input supply current	I_S	$V_{FEEDBACK}=14\text{V}(\text{switch off})$		7.5	10.0/ 14.0	mA
		$I_{SWITCH}=2.0\text{A}$ $V_{COMP}=2.0\text{V}(\text{max duty cycle})$		25	50/ 85	mA
Input supply undervoltage lockout	V_{UV}	$I_{SWITCH}=100\text{mA}$	2.70/ 2.65	290	3.10/ 3.15	V
Oscillator frequency	f_O	Measured at switch pin $I_{SWITCH}=100\text{mA}$	48/ 42	52	56/ 62	kHz
Output reference voltage	V_{REF}	Measured at feedback pin $V_{IN}=3.5\text{V to }40\text{V}$ $V_{COMP}=1.0\text{V}$	11.76/ 11.64	12	12.24/ 12.36	V
Output reference voltage line regulator	$\frac{\Delta V_{REF}}{\Delta V_{IN}}$	$V_{IN}=3.5\text{V to }40\text{V}$		7		mV
Feedback pin input resistance	R_{FB}			9.7		k Ω
Error amp transconductance	G_M	$I_{COMP}=-30\mu\text{A to }+30\mu\text{A}$ $V_{COMP}=1.0\text{V}$	225/ 145	370	515/ 615	μmho
Device Parameters						
Error amp voltage gain	A_{VOL}	$V_{COMP}=1.1\text{V to }1.9\text{V}$ $R_{COMP}=1.0\text{M}\Omega$ *6	50/ 25	80		V/V
Error amplifier output swing		Upper limit $V_{FEEDBACK}=10.0\text{V}$	2.2/ 2.0	2.4		V
		Lower limit $V_{FEEDBACK}=15.0\text{V}$		0.3	0.40/ 0.55	V
Error amplifier output current		$V_{FEEDBACK}=10.0\text{V to }15.0\text{V}$ $V_{COMP}=1.0\text{V}$	± 130 / ± 90	± 200	± 300 / ± 400	μA
Soft start current	I_{SS}	$V_{FEEDBACK}=10.0\text{V}$ $V_{COMP}=0\text{V}$	2.5/ 1.5	5.0	7.5/ 9.5	μA
Maximum duty cycle	D	$V_{COMP}=1.5\text{V}$ $I_{SWITCH}=100\text{mA}$	93/ 90	95		%

Continues:

Characteristic	Symbol	Test conditions	Min. *3	Typ.	Max *3	Unit
Switch transconductance	$\frac{\Delta I_{SWITCH}}{\Delta V_{COMP}}$			12.5		A/V
Switch leakage current	I_L	$V_{SWITCH}=65V$ $V_{FEEDBACK}=15V(\text{switch off})$		10	300/ 600	μA
Switch saturation current	V_{SAT}	$I_{SWITCH}=2.0A$ $V_{COMP}=2.0V(\text{max duty cycle})$		0.5	0.7/ 0.9	V
NPN switch current limit			3.7/ 3.0	4.5	5.3/ 6.0	A

LM2577-15

Characteristic	Symbol	Test conditions	Min. *3	Typ.	Max *3	Unit
System Parameters circuit of figure 2 *4						
Output voltage	V_{OUT}	$V_{IN}=5V \text{ to } 12V$ $I_{LOAD}=100mA \text{ to } 600mA$ *5	14.50/ 14.25	15	15.50/ 15.75	V
Line regulation	$\frac{\Delta V_{OUT}}{\Delta V_{IN}}$	$V_{IN}=3.5V \text{ to } 12V$ $I_{LOAD}=300mA$		20	50/ 100	mV
Load regulation	$\frac{\Delta V_{OUT}}{\Delta I_{LOAD}}$	$V_{IN}=5V,$ $I_{LOAD}=100mA \text{ to } 600mA$		20	50/ 100	mV
Efficiency	η	$V_{IN}=5V, I_{LOAD}=600mA$		80		%
Device Parameters						
Input supply current	I_S	$V_{FEEDBACK}=18V(\text{switch off})$		7.5	10.0/ 14.0	mA
		$I_{SWITCH}=2.0A$ $V_{COMP}=2.0V(\text{max duty cycle})$		25	50/ 85	mA
Input supply undervoltage lockout	V_{UV}	$I_{SWITCH}=100mA$	2.70/ 2.65	2.90	3.10/ 3.15	V
Oscillator frequency	f_O	Measured at switch pin $I_{SWITCH}=100mA$	48/ 42	52	56/ 62	kHz
Output reference voltage	V_{REF}	Measured at feedback pin $V_{IN}=3.5V \text{ to } 40V$ $V_{COMP}=1.0V$	14.70/ 14.55	15	15.30/ 15.45	V
Output reference voltage line regulator	$\frac{\Delta V_{REF}}{\Delta V_{IN}}$	$V_{IN}=3.5V \text{ to } 40V$		10		mV
Feedback pin input resistance	R_{FB}			122		k Ω
Error amp transconductance	G_M	$I_{COMP}=-30\mu A \text{ to } +30\mu A$ $V_{COMP}=1.0V$	170/ 110	300	420/ 500	μmho
Device Parameters						
Error amp voltage gain	A_{VOL}	$V_{COMP}=1.1V \text{ to } 1.9V$ $R_{COMP}=1.0M\Omega$ *6	40/ 20	65		V/V
Error amplifier output swing		Upper limit $V_{FEEDBACK}=12.0V$	2.2/ 2.0	2.4		V
		Lower limit $V_{FEEDBACK}=18.0V$		0.3	0.40/ 0.55	V

Continues:

Characteristic	Symbol	Test conditions	Min. *3	Typ.	Max *3	Unit
Error amplifier output current		V _{FEEDBACK} =12.0V to 18.0V V _{COMP} =1.0V	±130/ ±90	±200	±300/ ±400	μA
Soft start current	I _{SS}	V _{FEEDBACK} =12.0V V _{COMP} =0V	2.5/ 1.5	5.0	7.5/ 9.5	μA
Maximum duty cycle	D	V _{COMP} =1.5V I _{SWITCH} =100mA	93/ 90	95		%
Switch transconductance	$\frac{\Delta I_{SWITCH}}{\Delta V_{COMP}}$			12.5		A/V
Switch leakage current	I _L	V _{SWITCH} =65V V _{FEEDBACK} =18V (switch off)		10	300/ 600	μA
Switch saturation current	V _{SAT}	I _{SWITCH} =2.0A V _{COMP} =2.0V (max duty cycle)		0.5	0.7/ 0.9	V
NPN switch current limit		V _{COMP} =2.0V	3.7/ 3.0	43	5.3/ 6.0	A

LM2577-ADJ V_{FEEDBACK}=V_{REF}

Characteristic	Symbol	Test conditions	Min. *3	Typ.	Max *3	Unit
System Parameters circuit of figure 3 *4						
Output voltage	V _{OUT}	V _{IN} =5V to 10V I _{LOAD} =100mA to 800mA *5	11.60/ 11.40	12	12.40/ 12.60	V
Line regulation	$\frac{\Delta V_{OUT}}{\Delta V_{IN}}$	V _{IN} =3.5V to 10V I _{LOAD} =300mA		20	50/ 100	mV
Load regulation	$\frac{\Delta V_{OUT}}{\Delta I_{LOAD}}$	V _{IN} =5V, I _{LOAD} =100mA to 800mA		20	50/ 100	mV
Efficiency	η	V _{IN} =5V, I _{LOAD} =800mA		80		%
Device Parameters						
Input supply current	I _S	V _{FEEDBACK} =1.5V (switch off)		7.5	10.0/ 14.0	mA
		I _{SWITCH} =2.0A V _{COMP} =2.0V (max duty cycle)		25	50/ 85	mA
Input supply undervoltage lockout	V _{UV}	I _{SWITCH} =100mA	2.70/ 2.65	2.90	3.10/ 3.15	V
Oscillator frequency	f _O	Measured at switch pin I _{SWITCH} =100mA	48/ 42	52	56/ 62	kHz
Output reference voltage	V _{REF}	Measured at feedback pin V _{IN} =3.5V to 40V V _{COMP} =1.0V	1.214/ 1.206	1.230	1.246/ 1.254	V
Output reference voltage line regulator	$\frac{\Delta V_{REF}}{\Delta V_{IN}}$	V _{IN} =3.5V to 40V		0.5		mV
Error amp input bias current	I _B	V _{COMP} =1.0V		100	300/8 00	nA

Continues:

Characteristic	Symbol	Test conditions	Min. *3	Typ.	Max *3	Unit
Error amp transconductance	G_M	$I_{COMP}=-30\mu A$ to $+30\mu A$ $V_{COMP}=1.0V$	2400/1 600	3700	4800/ 5800	μmho
Device Parameters						
Error amp voltage gain	A_{VOL}	$V_{COMP}=1.1V$ to $1.9V$ $R_{COMP}=1.0M\Omega$ *6	500/ 250	800		V/V
Error amplifier output swing		Upper limit $V_{FEEDBACK}=1.0V$	2.2/ 2.0	2.4		V
		Lower limit $V_{FEEDBACK}=1.5V$		0.3	0.40/ 0.55	V
Error amplifier output current		$V_{FEEDBACK}=12.0V$ to $18.0V$ $V_{COMP}=1.0V$	± 130 / ± 90	± 200	± 300 / ± 400	μA
Soft start current	I_{SS}	$V_{FEEDBACK}=1.0V$ $V_{COMP}=0V$	2.5/ 1.5	5.0	7.5/ 9.5	μA
Maximum duty cycle	D	$V_{COMP}=1.5V$ $I_{SWITCH}=100mA$	93/ 90	95		%
Switch transconductance	$\frac{\Delta I_{SWITCH}}{\Delta V_{COMP}}$			125		A/V
Switch leakage current	I_L	$V_{SWITCH}=65V$ $V_{FEEDBACK}=1.5V$ (switch off)		10	300/ 600	μA
Switch saturation current	V_{SAT}	$I_{SWITCH}=2.0A$ $V_{COMP}=2.0V$ (max duty cycle)		0.5	0.7/ 0.9	V
NPN switch current limit		$V_{COMP}=2.0V$	3.7/ 3.0	4.3	5.3/ 6.0	A

Thermal Paramters (All Versions)

Characteristic	Symbol	Test conditions	Min.	Typ	Max	Unit
Thermal resistance	θ_J	TO220-5, Junction to ambient TO220-5, Junction to case		65		$^{\circ}C/W$
	A			2		
	θ_{JC}					
Thermal resistance	θ_{JA}	TO263-5, Junction to ambient *7		37		

*1: Absolute Maximum Ratings indicate limits beyond which damage to the device may occur. Operating ratings indicate conditions the device is intended to be functional, but device parameter specifications may not be guaranteed under these conditions. For guaranteed specifications and test conditions, see the Electrical Characteristics.

*2: Due to timing considerations of the LM2577 current limit circuit, output current cannot be internally limited when the LM2577 is used as a step-up regulator. To prevent damage to the switch, its current must be externally limited to 6.0A. However, output current is internally limited when the LM2577 is used as a flyback or forward converter regulator in accordance to the Application Hints.

*3: All limits guaranteed at room temperature (standard type face) and at temperature extremes (boldface type).

All room temperature limits are 100% production tested. All limits at temperature extremes are guaranteed via correlation using standard Statistical Quality Control (SQC) methods.

*4: External components such as the diode, inductor, input and output capacitors can affect switching regulator performance. When the LM2577 is used as shown in the Test Circuit, system performance will be as specified by the system parameters.

*5: All limits guaranteed at room temperature (standard type face) and at temperature extremes (boldface type). All limits are used to calculate Outgoing Quality Level, and are 100% production tested.

*6: A 1.0 MΩ resistor is connected to the compensation pin (which is the error amplifier's output) to ensure accuracy in measuring AVOL. In actual applications, this pin's load resistance should be ≥ 10 MΩ, resulting in AVOL that is typically twice the guaranteed minimum limit.

*7: If the TO-263 package is used, the thermal resistance can be reduced by increasing the PC board copper area thermally connected to the package. Using 0.5 square inches of copper area, θ_{JA} is 50°C/W; with 1 square inch of copper area, θ_{JA} is 37°C/W; and with 1.6 or more square inches of copper area, θ_{JA} is 32°C/W.

Test Circuit

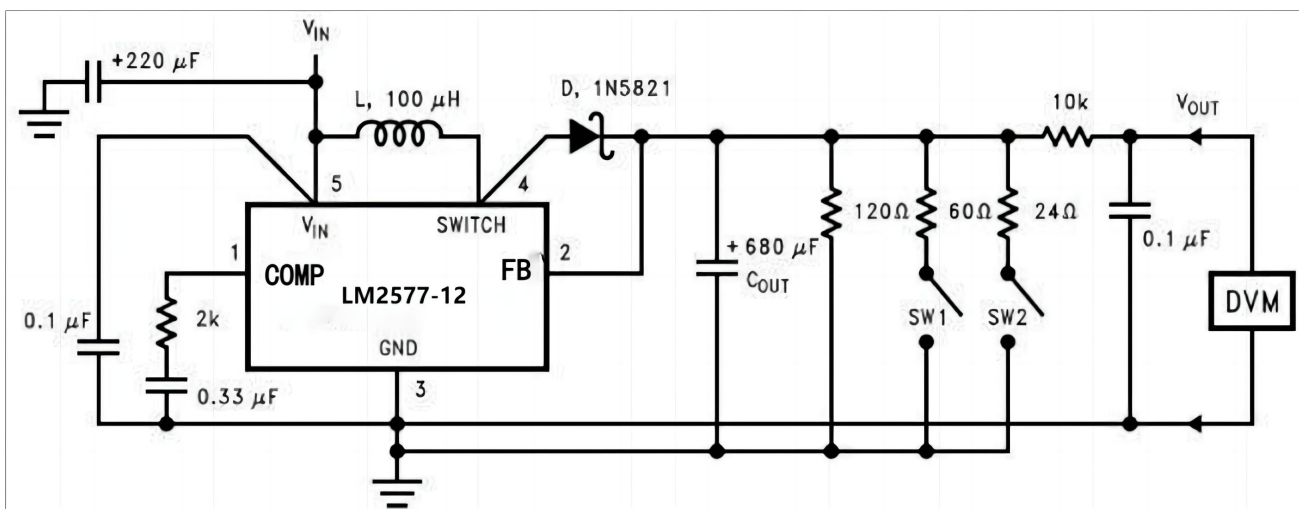

Figure.1 Circuit Used to Specify System Parameters for 12V Versions L =
415-0930 (AIE) D = any manufacturer
COUT = Sprague Type 673D Electrolytic 680μF, 20V

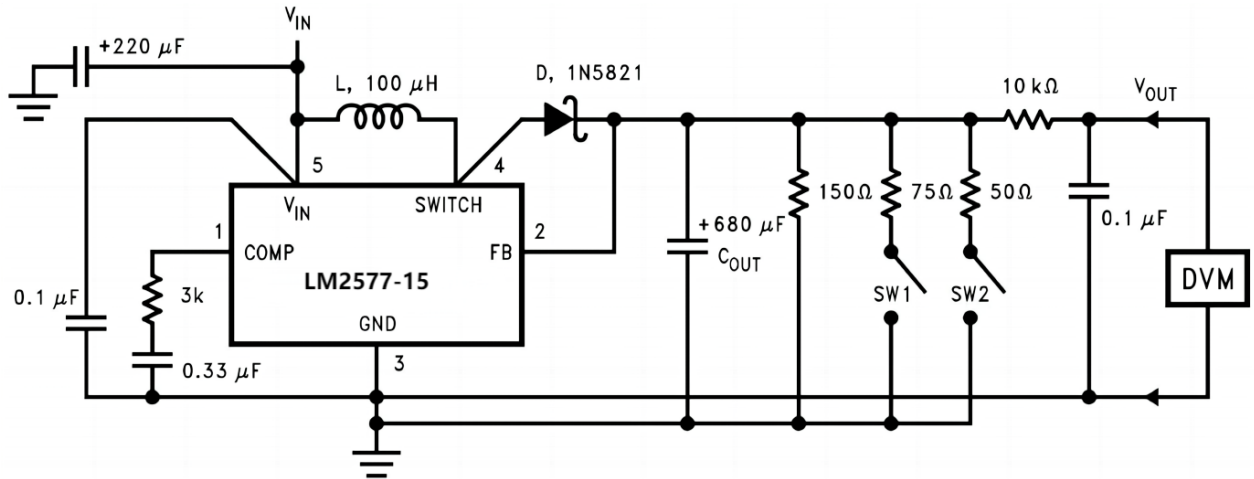

FIGURE 2. Circuit Used to Specify System Parameters for 15V Versions

L = 415-0930 (AIE)

D = any manufacturer

COUT = Sprague Type 673D

Electrolytic 680μF, 20V

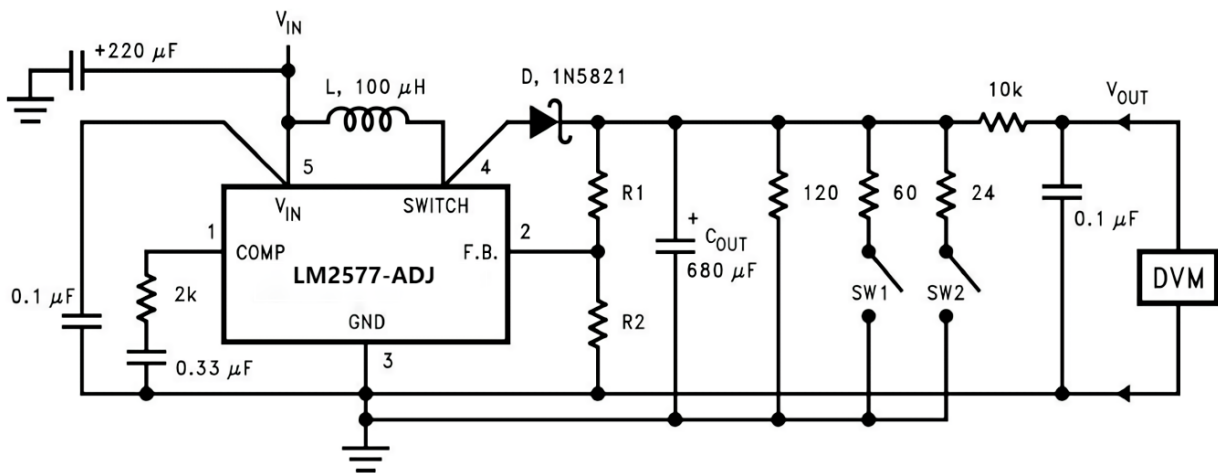

FIGURE 3. Circuit Used to Specify System Parameters for ADJ Versions

L = 415-0930 (AIE)

D = any manufacturer

COUT = Sprague Type 673D

Electrolytic 680 μF, 20V

R1 = 48.7k in series with 511Ω (1%)

R2 = 5.62k (1%)

Application Data

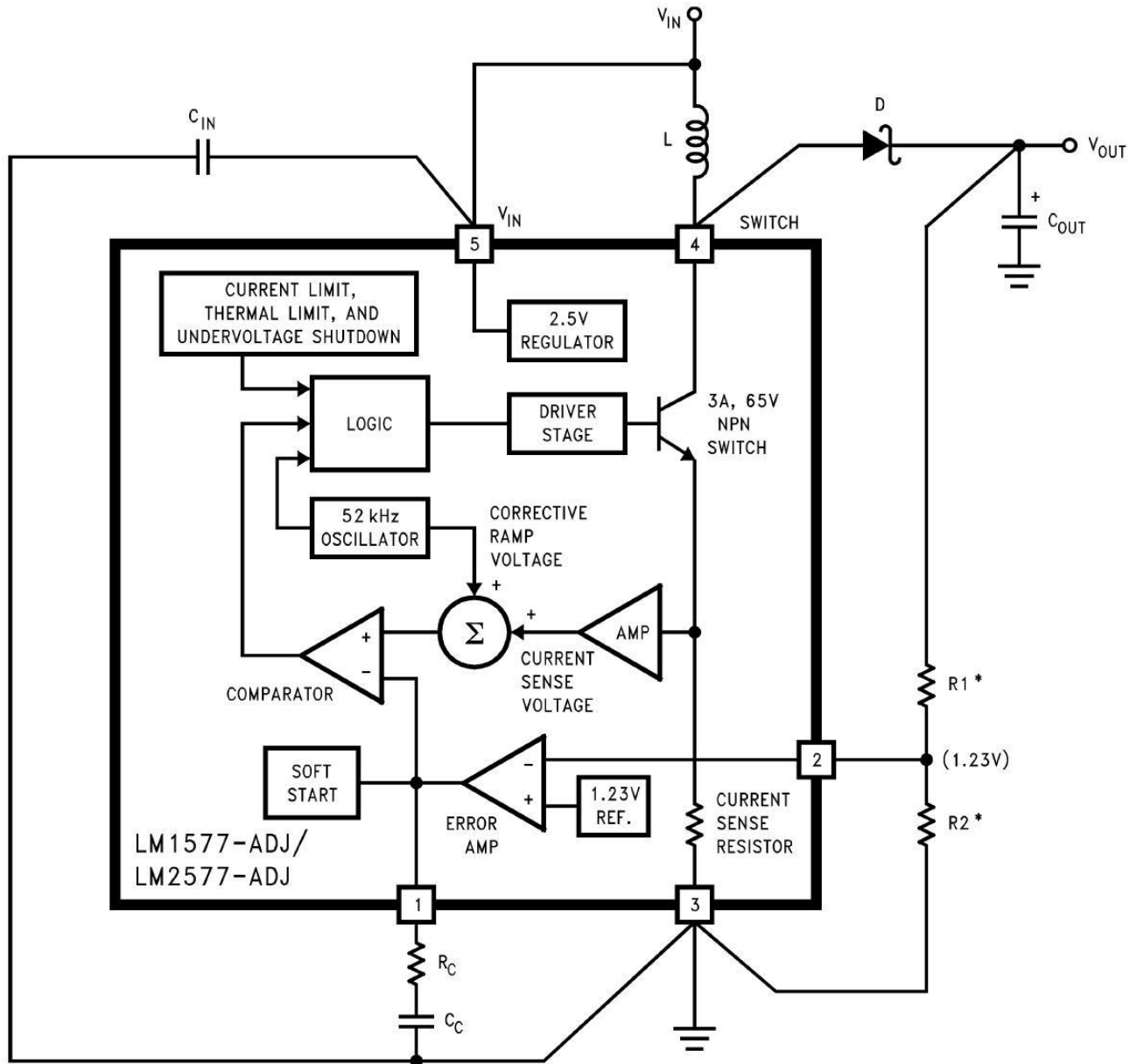

FIGURE 4. LM2577 Block Diagram and Boost Regulator Application

Step-Up (boost) Regulator

Figure 4 shows the LM2577-ADJ used as a Step-Up Regulator. This is a switching regulator used for producing an output voltage greater than the input supply voltage. The LM2577-12 and LM2577-15 can also be used for step-up regulators with 12V or 15V outputs (respectively), by tying the feedback pin directly to the regulator output.

A basic explanation of how it works is as follows. The LM2577 turns its output switch on and off at a frequency of 52 kHz, and this creates energy in the inductor (L). When the NPN switch turns on, the inductor current charges up at a rate of V_{IN}/L , storing current in the inductor. When the switch turns off, the lower end of the inductor flies above V_{IN} , discharging its current through diode (D) into the output capacitor (C_{OUT}) at a rate of $(V_{OUT} - V_{IN})/L$. Thus, energy stored in the inductor during the switch on time is transferred to the output during the switch off time.

The output voltage is controlled by the amount of energy transferred which, in turn, is controlled by modulating the peak inductor current. This is done by feeding back a portion of the output voltage to the error amp,

which amplifies the difference between the feedback voltage and a 1.230V reference. The error amp output voltage is compared to a voltage proportional to the switch current (i.e., inductor current during the switch on time).

The comparator terminates the switch on time when the two voltages are equal, thereby controlling the peak switch current to maintain a constant output voltage. Voltage and current waveforms for this circuit are shown in Figure 5, and formulas for calculating them are given in Figure 6.

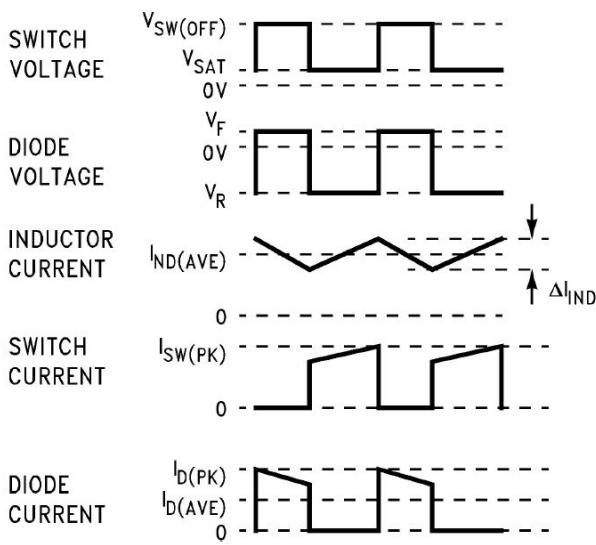

FIGURE 5. Step-Up Regulator Waveforms

Duty Cycle	D	$\frac{V_{OUT} + V_F - V_{IN}}{V_{OUT} + V_F - V_{SAT}} \approx \frac{V_{OUT} - V_{IN}}{V_{OUT}}$
Average Inductor Current	$I_{IND(AVE)}$	$\frac{I_{LOAD}}{1 - D}$
Inductor Current Ripple	ΔI_{IND}	$\frac{V_{IN} - V_{SAT}}{L} \cdot \frac{D}{52,000}$
Peak Inductor Current	$I_{IND(PK)}$	$\frac{I_{LOAD(max)}}{1 - D_{(max)}} + \frac{\Delta I_{IND}}{2}$
Peak Switch Current	$I_{SW(PK)}$	$\frac{I_{LOAD(max)}}{1 - D_{(max)}} + \frac{\Delta I_{IND}}{2}$
Switch Voltage When Off	$V_{SW(OFF)}$	$V_{OUT} + V_F$
Diode Reverse Voltage	V_R	$V_{OUT} - V_{SAT}$
Average Diode Current	$I_{D(AVE)}$	I_{LOAD}
Peak Diode Current	$I_{D(PK)}$	$\frac{I_{LOAD}}{1 - D_{(max)}} + \frac{\Delta I_{IND}}{2}$
Power Dissipation of LM2577	P_D	$0.25\Omega \left(\frac{I_{LOAD}}{1 - D} \right)^2 D + \frac{I_{LOAD} D V_{IN}}{50(1 - D)}$

V_F = Forward Biased Diode Voltage
 I_{LOAD} = Output Load Current

FIGURE 6 Step Up Regulator Formulas

Step-Up Regulator Design Procedure

The following design procedure can be used to select the appropriate external components for the circuit in Figure 4, based on these system requirements.

Given:

$V_{IN(min)}$ = Minimum input supply voltage

V_{OUT} = Regulated output voltage

$I_{LOAD(max)}$ = Maximum output load current

Before proceeding any further, determine if the LM2577 can provide these values of V_{OUT} and $I_{LOAD(max)}$ when operating with the minimum value of V_{IN} . The upper limits for V_{OUT} and $I_{LOAD(max)}$ are given by the following equations.

$$V_{OUT} \leq 60V$$

$$\text{and } V_{OUT} \leq 10 \times V_{IN(min)} \quad I_{LOAD(max)} \leq \frac{2.1A \times V_{IN(min)}}{V_{OUT}}$$

These limits must be greater than or equal to the values specified in this application.

1. Inductor Selection (L)

A. Voltage Options:

1. For 12V or 15V output From Figure 7 (for 12V output) or Figure 8 (for 15V output), identify inductor code for region indicated by $V_{IN(min)}$ and $I_{LOAD(max)}$. The shaded region indicates conditions for which the LM2577 output switch would be operating beyond its switch current rating.

The minimum operating voltage for the LM2577 is 3.5V. From here, proceed to step C.

2. For Adjustable version Preliminary calculations:

The inductor selection is based on the calculation of the following three parameters:

$D_{(max)}$, the maximum switch duty cycle ($0 \leq D \leq 0.9$):

$$D_{(max)} = \frac{V_{OUT} + V_F - V_{IN(min)}}{V_{OUT} + V_F - 0.6V}$$

where $V_F = 0.5V$ for Schottky diodes and $0.8V$ for fast recovery diodes (typically);

$E \cdot T$, the product of volts x time that charges the inductor:

$$E \cdot T = \frac{D_{(max)} (V_{IN(min)} - 0.6V) 10^6}{52,000 \text{ Hz}} \quad (V \cdot \mu s)$$

$I_{IND,DC}$, the average inductor current under full load;

$$I_{IND,DC} = \frac{1.05 \times I_{LOAD(max)}}{1 - D_{(max)}}$$

B. Identify Inductor Value:

1. From Figure 9, identify the inductor code for the region indicated by the intersection of E•T and IIND,DC. This code gives the inductor value in microhenries. The L or H prefix signifies whether the inductor is rated for a maximum E•T of 90 V•μs (L) or 250 V•μs (H).
2. If $D < 0.85$, go on to step C. If $D \geq 0.85$, then calculate the minimum inductance needed to ensure the switching regulator's stability:

$$L_{MIN} = \frac{6.4 (V_{IN(min)} - 0.6V) (2D_{(max)} - 1)}{1 - D_{(max)}} \quad (\mu H)$$

If L_{MIN} is smaller than the inductor value found in step B1, go on to step C. Otherwise, the inductor value found in step B1 is too low; an appropriate inductor code should be obtained from the graph as follows:

1. Find the lowest value inductor that is greater than L_{MIN} .
2. Find where E•T intersects this inductor value to determine if it has an L or H prefix. If E•T intersects both the L and H regions, select the inductor with an H prefix.

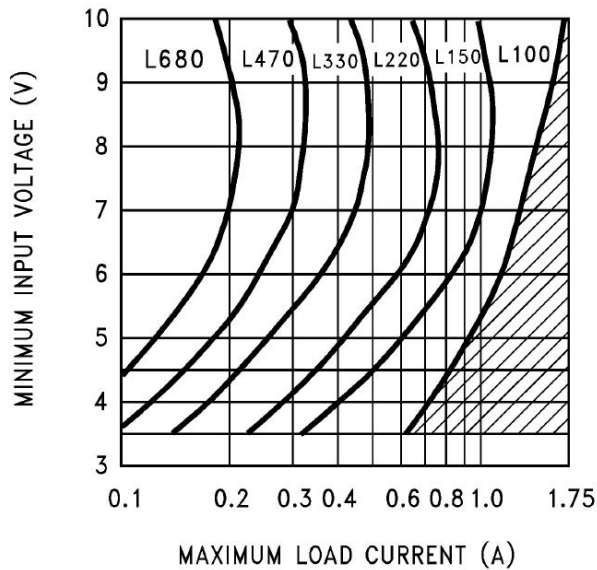

FIGURE 7. LM2577-12 Inductor Selection Guide

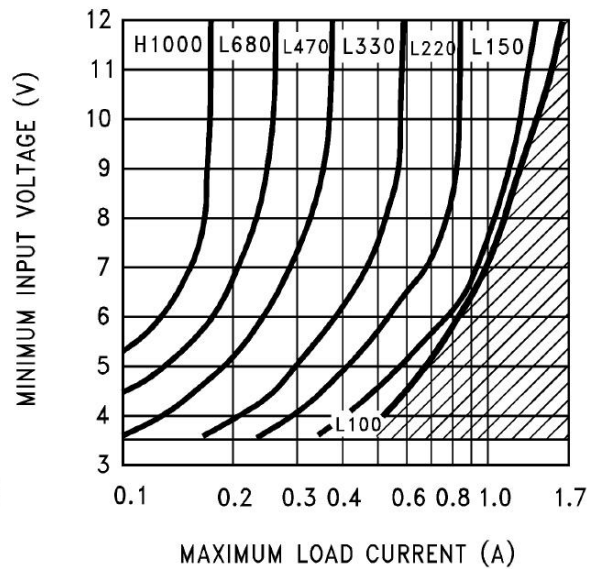
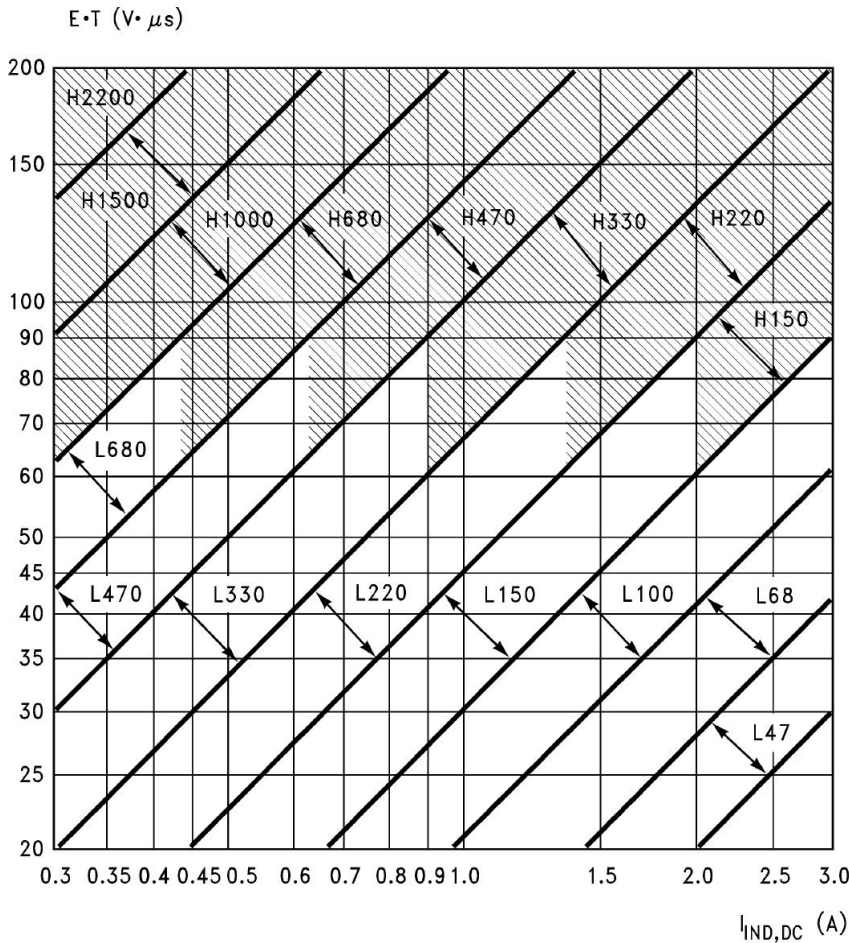

FIGURE 8. LM2577-15 Inductor Selection Guide



Note: These charts assume that the inductor ripple current is approximately 20% to 30% of the average inductor current (when the regulator is under full load). Greater ripple current causes higher peak switch currents and greater output ripple voltage; lower ripple current is achieved with larger-value inductors. The factor of 20 to 30% is chosen as a convenient balance between the two

FIGURE 9. LM2577-ADJ Inductor Selection Graph

C. Select an inductor from the table of Figure 10 which cross-references the inductor codes to the part numbers of three different manufacturers. Complete specifications for these inductors are available from the respective manufacturers. The inductors listed in this table have the following characteristics:

AIE: ferrite, pot-core inductors; Benefits of this type are low electro-magnetic interference (EMI), small physical size, and very low power dissipation (core loss). Be careful not to operate these inductors too far beyond their maximum ratings for E•T and peak current, as this will saturate the core.

Pulse: powdered iron, toroid core inductors; Benefits are low EMI and ability to withstand E•T and peak current above rated value better than ferrite cores.

Renco: ferrite, bobbin-core inductors; Benefits are low cost and best ability to withstand E•T and peak current above rated value. Be aware that these inductors generate more EMI than the other types, and this may interfere with signals sensitive to noise.

Inductor Code	Manufacturer's Part Number		
	Schott	Pulse	Renco
L47	67126980	PE - 53112	RL2442
L68	67126990	PE - 92114	RL2443
L100	67127000	PE - 92108	RL2444
L150	67127010	PE - 53113	RL1954
L220	67127020	PE - 52626	RL1953
L330	67127030	PE - 52627	RL1952
L470	67127040	PE - 53114	RL1951
L680	67127050	PE - 52629	RL1950
H150	67127060	PE - 53115	RL2445
H220	67127070	PE - 53116	RL2446
H330	67127080	PE - 53117	RL2447
H470	67127090	PE - 53118	RL1961
H680	67127100	PE - 53119	RL1960
H1000	67127110	PE - 53120	RL1959
H1500	67127120	PE - 53121	RL1958
H2200	67127130	PE - 53122	RL2448

FIGURE 10. Table of Standardized Inductors and Manufacturer's Part Numbers

2. Compensation Network (R_C, C_C) and Output Capacitor(C_{OUT}) Selection

R_C and C_C form a pole-zero compensation network that stabilizes the regulator. The values of R_C and C_C are mainly dependant on the regulator voltage gain, I_{LOAD(max)}, L and C_{OUT}. The following procedure calculates values for R_C, C_C, and C_{OUT} that ensure regulator stability. Be aware that this procedure doesn't necessarily result in R_C and C_C that provide optimum compensation. In order to guarantee optimum compensation, one of the standard procedures for testing loop stability must be used, such as measuring V_{OUT} transient response when pulsing I_{LOAD} (see Figure 15).

A. First, calculate the maximum value for R_C.

$$R_C \leq \frac{750 \times I_{LOAD(max)} \times V_{OUT}^2}{V_{IN(min)}^2}$$

Select a resistor less than or equal to this value, and it should also be no greater than 3 kΩ.

B. Calculate the minimum value for C_{OUT} using the following two equations.

$$C_{OUT} \geq \frac{0.19 \times L \times R_C \times I_{LOAD(max)}}{V_{IN(min)} \times V_{OUT}}$$

and

$$C_{OUT} \geq \frac{V_{IN(min)} \times R_C \times (V_{IN(min)} + (3.74 \times 10^5 \times L))}{487,800 \times V_{OUT}^3}$$

The larger of these two values is the minimum value that ensures stability.

C. Calculate the minimum value of C_C .

$$C_C \geq \frac{58.5 \times V_{OUT}^2 \times C_{OUT}}{R_C^2 \times V_{IN(min)}}$$

The compensation capacitor is also part of the soft start circuitry. When power to the regulator is turned on, the switch duty cycle is allowed to rise at a rate controlled by this capacitor (with no control on the duty cycle, it would immediately rise to 90%, drawing huge currents from the input power supply). In order to operate properly, the soft start circuit requires $C_C \geq 0.22 \mu\text{F}$.

The value of the output filter capacitor is normally large enough to require the use of aluminum electrolytic capacitors. Figure 11 lists several different types that are recommended for switching regulators, and the following parameters are used to select the proper capacitor.

Working Voltage (WVDC): Choose a capacitor with a working voltage at least 20% higher than the regulator output voltage.

Ripple Current: This is the maximum RMS value of current that charges the capacitor during each switching cycle. For step-up and flyback regulators, the formula for ripple current is

$$I_{RIPPLE(RMS)} = \frac{I_{LOAD(max)} \times D_{(max)}}{1 - D_{(max)}}$$

Choose a capacitor that is rated at least 50% higher than this value at 52 kHz.

Equivalent Series Resistance (ESR) : This is the primary cause of output ripple voltage, and it also affects the values of R_C and C_C needed to stabilize the regulator. As a result, the preceding calculations for C_C and R_C are only valid if ESR doesn't exceed the maximum value specified by the following equations.

$$ESR \leq \frac{0.01 \times V_{OUT}}{I_{RIPPLE(P-P)}} \text{ and } \leq \frac{8.7 \times (10) - 3 \times V_{IN}}{I_{LOAD(max)}}$$

where

$$I_{RIPPLE(P-P)} = \frac{1.15 \times I_{LOAD(max)}}{1 - D_{(max)}}$$

Select a capacitor with ESR, at 52 kHz, that is less than or equal to the lower value calculated. Most electrolytic capacitors specify ESR at 120 Hz which is 15% to 30% higher than at 52 kHz. Also, be aware that ESR increases by a factor of 2 when operating at -20°C .

In general, low values of ESR are achieved by using large value capacitors ($C \geq 470 \mu\text{F}$), and capacitors with high WVDC, or by paralleling smaller-value capacitors.

3. Output Voltage Selection (R1 and R2)

This section is for applications using the LM2577-ADJ. Skip this section if the LM2577-12 or LM2577-15 is being used. With the LM2577-ADJ, the output voltage is given by

$$V_{OUT} = 1.23V (1 + R1/R2)$$

Resistors R1 and R2 divide the output down so it can be compared with the LM2577-ADJ internal 1.23V reference. For a given desired output voltage V_{OUT} , select R1 and R2 so that

$$\frac{R1}{R2} = \frac{V_{OUT}}{1.23V} - 1$$

4. Diode Selection (D)

The switching diode used in the boost regulator must withstand a reverse voltage equal to the circuit output voltage, and must conduct the peak output current of the LM2577.

A suitable diode must have a minimum reverse breakdown voltage greater than the circuit output voltage, and should be rated for average and peak current greater than $I_{LOAD(max)}$ and $I_{D(PK)}$.

Schottky barrier diodes are often favored for use in switching regulators.

Their low forward voltage drop allows higher regulator efficiency than if a (less expensive) fast recovery diode was used. See Figure 11 for recommended part numbers and voltage ratings of 1A and 3A diodes.

V_{OUT} (max)	Schottky		Fast Recovery	
	1A	3A	1A	3A
20V	1N5817 MBR120P	1N5820 MBR320P		
30V	1N5818 MBR130P 11DQ03	1N5821 MBR330P 31DQ03		
40V	1N5819 MBR140P 11DQ04	1N5822 MBR340P 31DQ04		
50V	MBR150 11DQ05	MBR350 31DQ05	1N4933 MUR105	
100V			1N4934 HER102 MUR110 10DL1	MR851 30DL1 MR831 HER302

FIGURE 11. Diode Selection Chart

Boost Regulator Circuit Example

By adding a few external components (as shown in Figure 12), the LM2577 can be used to produce a regulated output voltage that is greater than the applied input voltage. Typical performance of this regulator is shown in Figure 13 and Figure 14. The switching waveforms observed during the operation of this circuit are shown in Figure 15.

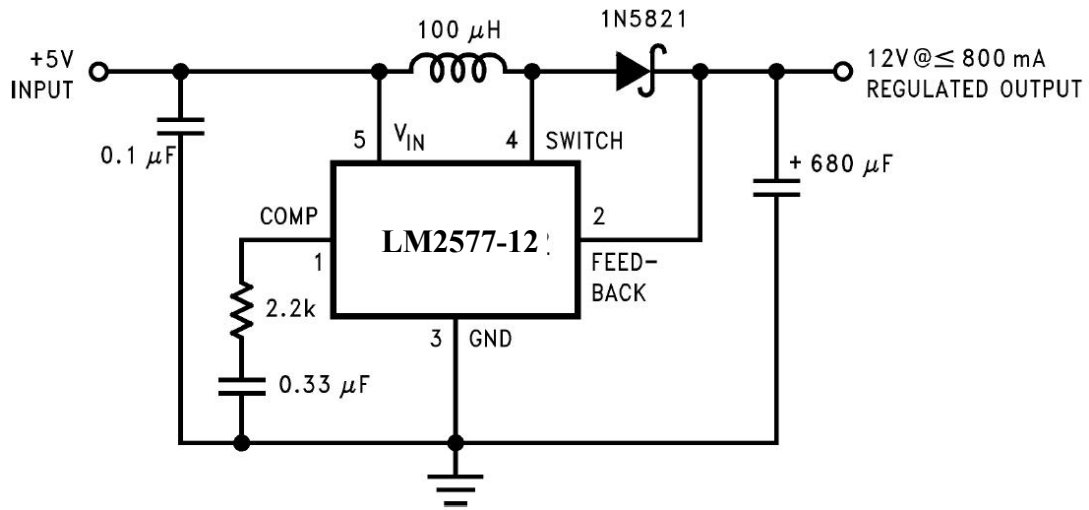

FIGURE 12. Step-up Regulator Delivers 12V from a 5V Input

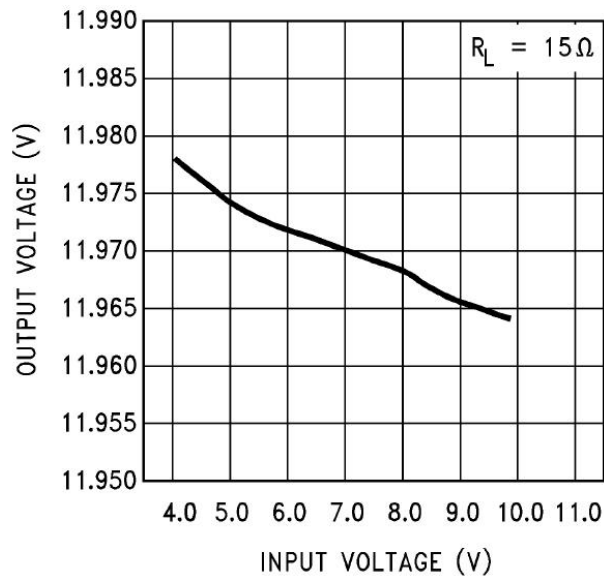
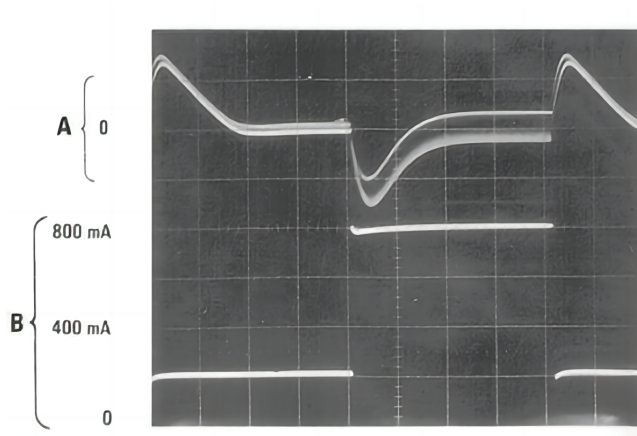

FIGURE 13. Line Regulation (Typical) of Step-Up Regulator of Figure 12



A: Output Voltage Change, 100 mV/div. (AC-coupled)

B: Load current, 0.2 A/div

Horizontal: 5 ms/div

FIGURE 14. Load Transient Response of Step-Up Regulator of Figure 12

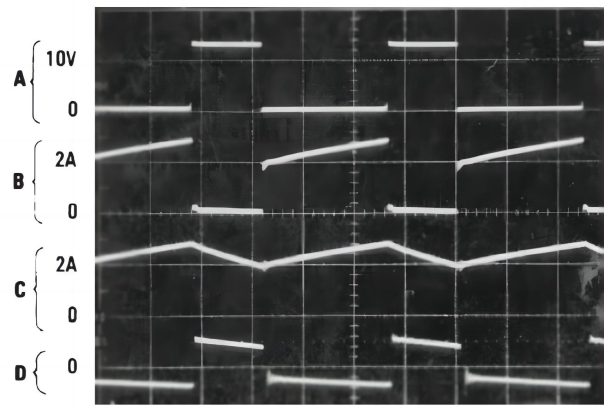

A: Switch pin voltage, 10 V/div

B: Switch pin current, 2 A/div

C: Inductor current, 2 A/div

D: Output ripple voltage, 100 mV/div (AC-coupled)

Horizontal: 5 μs/div

FIGURE 15. Switching Waveforms of Step-Up Regulator of Figure 12

Flyback Regulator

A Flyback regulator can produce single or multiple output voltages that are lower or greater than the input supply voltage. Figure 18 shows the LM2577 used as a flyback regulator with positive and negative regulated outputs. Its operation is similar to a step-up regulator, except the output switch controls the primary current of a flyback transformer. Note that the primary and secondary windings are out of phase, so no current flows through secondary when current flows through the primary. This allows the primary to charge up the transformer core when the switch is on. When the switch turns off, the core discharges by sending current through the secondary, and this produces voltage at the outputs. The output voltages are controlled by adjusting the peak primary current, as described in the step-up regulator section.

Voltage and current waveforms for this circuit are shown in Figure 16, and formulas for calculating them are given in Figure 18.

Flyback Regulator Design Procedure

1. Transformer Selection

A family of standardized flyback transformers is available for creating flyback regulators that produce dual output voltages, from $\pm 10\text{V}$ to $\pm 15\text{V}$, as shown in Figure 17. Figure 19 lists these transformers with the input voltage, output voltages and maximum load current they are designed for.

2. Compensation Network (C_C, R_C) and Output Capacitor (C_{OUT}) Selection

As explained in the Step-Up Regulator Design Procedure, C_C, R_C and C_{OUT} must be selected as a group. The following procedure is for a dual output flyback regulator with equal turns ratios for each secondary (i.e., both output voltages have the same magnitude). The equations can be used for a single output regulator by changing $\Sigma I_{LOAD(max)}$ to I_{LOAD(max)} in the following equations.

A. First, calculate the maximum value for R_C.

$$R_C \leq \frac{750 \times \Sigma I_{LOAD(max)} \times (15V + V_{IN(min)}N)^2}{V_{IN(min)}^2}$$

Where $\Sigma I_{LOAD(max)}$ is the sum of the load current (magnitude) required from both outputs. Select a resistor less than or equal to this value, and no greater than 3 k Ω .

B. Calculate the minimum value for ΣC_{OUT} (sum of C_{OUT} at both outputs) using the following two equations.

$$C_{OUT} \geq \frac{0.19 \times R_C \times L_P \times \Sigma I_{LOAD(max)}}{15V \times V_{IN(min)}}$$

and

$$C_{OUT} \geq \frac{V_{IN(min)} \times R_C \times N^2 \times (V_{IN(min)} + (3.74 \times 10^5 \times L_P))}{487,800 \times (15V)^2 \times (15V + V_{IN(min)} \times N)}$$

The larger of these two values must be used to ensure regulator stability.

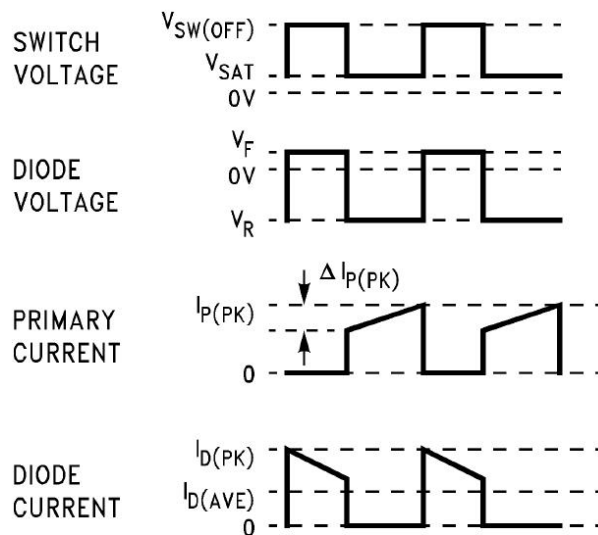
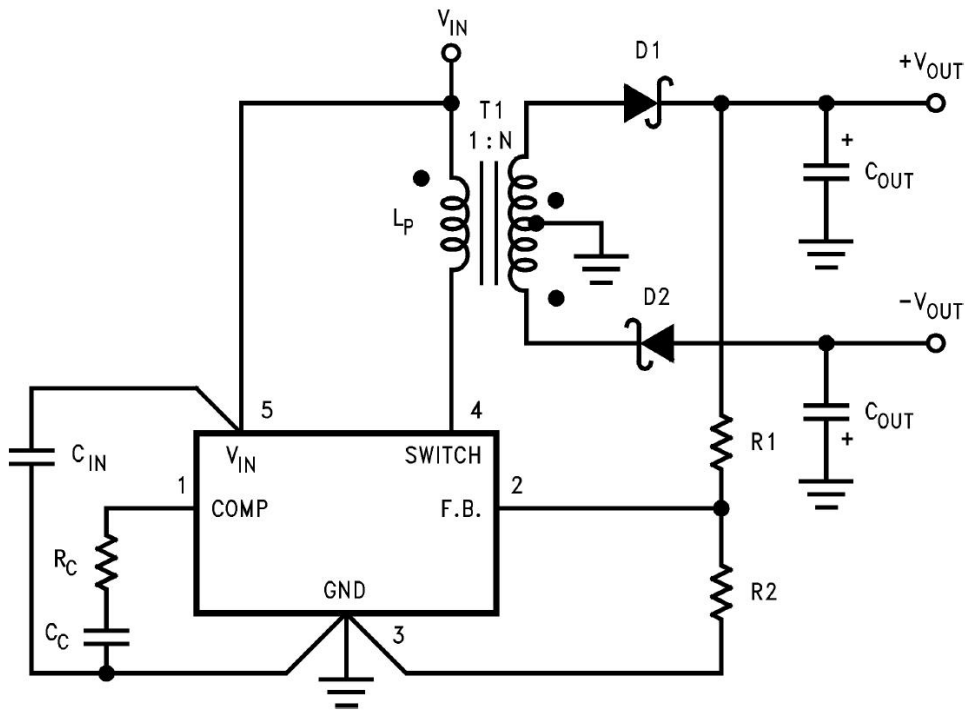

FIGURE 16. Flyback Regulator Waveforms



LM2577-ADJ

T1 = Pulse Engineering, PE-65300

D1, D2 = 1N5821

FIGURE 17. LM2577-ADJ Flyback Regulator with ±Outputs

Duty Cycle	D	$\frac{V_{OUT} + V_F}{N(V_{IN} - V_{SAT}) + V_{OUT} + V_F} \approx \frac{V_{OUT}}{N(V_{IN}) + V_{OUT}}$
Primary Current Variation	ΔI_P	$\frac{D(V_{IN} - V_{SAT})}{L_P \times 52,000}$
Peak Primary Current	$I_{P(PK)}$	$\frac{N}{\eta} \times \frac{\Sigma I_{LOAD}}{1 - D} + \frac{\Delta I_{PK}}{2}$
Switch Voltage when Off	$V_{SW(OFF)}$	$V_{IN} + \frac{V_{OUT} + V_F}{N}$
Diode Reverse Voltage	V_R	$V_{OUT} + N(V_{IN} - V_{SAT})$
Average Diode Current	$I_{D(AVE)}$	I_{LOAD}
Peak Diode Current	$I_{D(PK)}$	$\frac{I_{LOAD}}{1 - D} + \frac{\Delta I_{IND}}{2}$
Short Circuit Diode Current		$\approx \frac{6A}{N}$
Power Dissipation of LM2577	P_D	$0.25\Omega \left(\frac{N \Sigma I_{LOAD}}{1 - D} \right)^2 + \frac{N I_{LOAD} D}{50(1 - D)} V_{IN}$

$$N = \text{Transformer Turns Ratio} = \frac{\text{number of secondary turns}}{\text{number of primary turns}}$$

$$\eta = \text{Transformer Efficiency (typically 0.95)}$$

$$\Sigma I_{LOAD} = | +I_{LOAD} | + | -I_{LOAD} |$$

FIGURE 18. Flyback Regulator Formulas

Calculate the minimum value of C_C

$$C_C \geq \frac{58.5 \times C_{OUT} \times V_{OUT} \times (V_{OUT} + (V_{IN(min)} \times N))}{R_C^2 \times V_{IN(min)} \times N}$$

Calculate the maximum ESR of the $+V_{OUT}$ and $-V_{OUT}$ output capacitors in parallel.

$$ESR + \parallel ESR \leq \frac{8.7 \times 10^{-3} \times V_{IN(min)} \times V_{OUT} \times N}{\Sigma I_{LOAD(max)} \times (V_{OUT} + (V_{IN(min)} \times N))}$$

This formula can also be used to calculate the maximum ESR of a single output regulator.

At this point, refer to this same section in the Step-Up Regulator Design Procedure for more information regarding the selection of C_{OUT}

3. Output Voltage Selection

This section is for applications using the LM2577-ADJ. Skip this section if the LM2577-12 or LM2577-15 is being used. With the LM2577-ADJ, the output voltage is given by

$$V_{OUT} = 1.23V (1 + R1/R2)$$

Resistors R1 and R2 divide the output voltage down so it can be compared with the LM2577-ADJ internal 1.23V reference. For a desired output voltage V_{OUT} , select R1 and R2 so that

$$\frac{R1}{R2} = \frac{V_{OUT}}{1.23V} - 1$$

4. Diode Selection

The switching diode in a flyback converter must withstand the reverse voltage specified by the following equation.

$$V_R = V_{OUT} + \frac{V_{IN}}{N}$$

A suitable diode must have a reverse voltage rating greater than this. In addition it must be rated for more than the average and peak diode currents listed in Figure 18.

5. Input Capacitor Selection

The primary of a flyback transformer draws discontinuous pulses of current from the input supply. As a result, a flyback regulator generates more noise at the input supply than a step-up regulator, and this requires a larger bypass capacitor to decouple the LM2577 V_{IN} pin from this noise. For most applications, a low ESR, 1.0 μ F cap will be sufficient, if it is connected very close to the V_{IN} and Ground pins.

Transformer Type		Input Voltage	Dual Output Voltage	Maximum Output Current	Transformer Type	Manufacturers' Part Numbers		
						AIE	Pulse	Renco
1	L _p = 100 μH N = 1	5V	±10V	325 mA	1	326-0637	PE-65300	RL-2580
		5V	±12V	275 mA	2	330-0202	PE-65301	RL-2581
		5V	±15V	225 mA	3	330-0203	PE-65302	RL-2582
2	L _p = 200 μH N = 0.5	10V	±10V	700 mA				
		10V	±12V	575 mA				
		10V	±15V	500 mA				
		12V	±10V	800 mA				
		12V	±12V	700 mA				
3	L _p = 250 μH N = 0.5	15V	±10V	900 mA				
		15V	±12V	825 mA				
		15V	±15V	700 mA				

FIGURE 19. Flyback Transformer Selection Guide

In addition to this bypass cap, a larger capacitor ($\geq 47 \mu\text{F}$) should be used where the flyback transformer connects to the input supply. This will attenuate noise which may interfere with other circuits connected to the same input supply voltage.

6. Snubber Circuit

A “snubber” circuit is required when operating from input voltages greater than 10V, or when using a transformer with $L_p \geq 200 \mu\text{H}$. This circuit clamps a voltage spike from the transformer primary that occurs immediately after the output switch turns off. Without it, the switch voltage may exceed the 65V maximum rating. As shown in Figure 20, the snubber consists of a fast recovery diode, and a parallel RC. The RC values are selected for switch clamp voltage (V_{CLAMP}) that is 5V to 10V greater than $V_{\text{SW(OFF)}}$. Use the following equations to calculate R and C;

$$C \geq \frac{0.02 \times L_p \times I_{\text{P(PK)}}^2}{(V_{\text{CLAMP}})^2 - (V_{\text{SW(OFF)}})^2}$$

$$R \leq \left(\frac{V_{\text{CLAMP}} + V_{\text{SW(OFF)}} - V_{\text{IN}}}{2} \right)^2 \times \left(\frac{19.2 \times 10^{-4}}{L_p \times I_{\text{P(PK)}}^2} \right)$$

Power dissipation (and power rating) of the resistor is;

$$P = \left(\frac{V_{\text{CLAMP}} + V_{\text{SW(OFF)}} - V_{\text{IN}}}{2} \right)^2 / R$$

The fast recovery diode must have a reverse voltage rating greater than V_{CLAMP} .

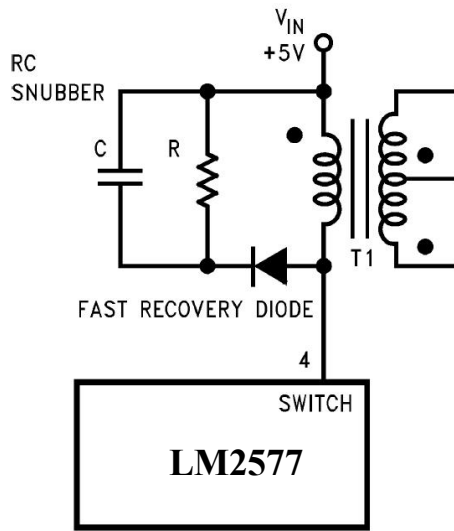
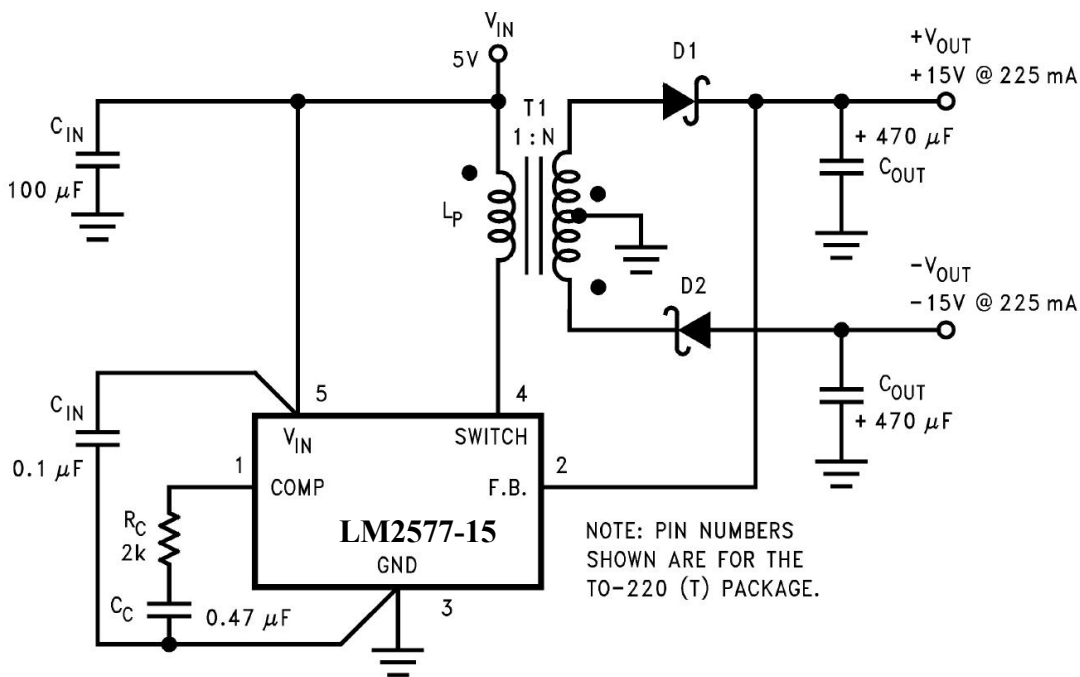

FIGURE 20. Snubber Circuit

Flyback Regulator Circuit Example

The circuit of Figure 21 produces $\pm 15\text{V}$ (at 225 mA each) from a single 5V input. The output regulation of this circuit is shown in Figure 22 and Figure 24, while the load transient response is shown in Figure 23 and Figure 25. Switching waveforms seen in this circuit are shown in Figure 26.



T1 = Pulse Engineering, PE-65300

D1, D2 = 1N5821

FIGURE 21. Flyback Regulator Easily Provides Dual Outputs

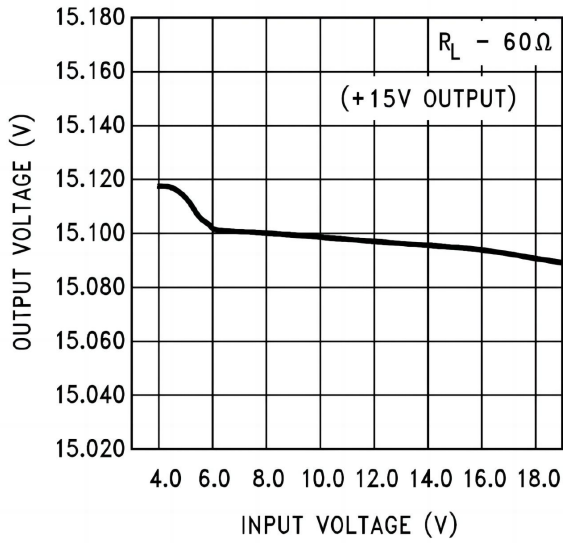

FIGURE 22. Line Regulation (Typical) of Flyback Regulator of Figure 21, +15V Output

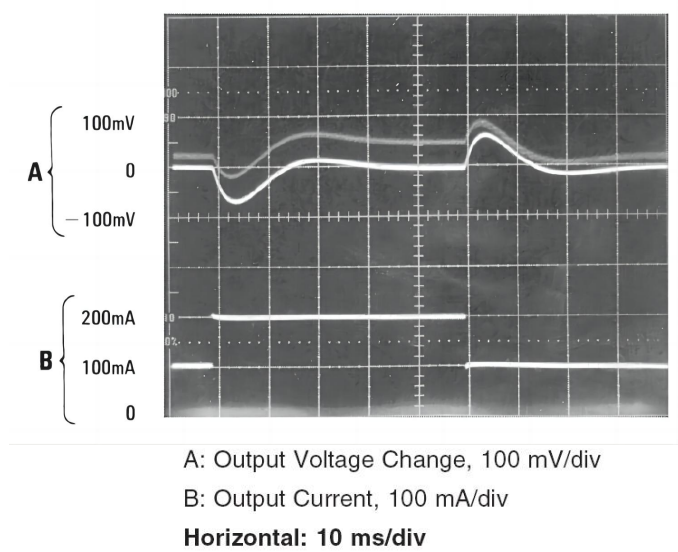

FIGURE 23. Load Transient Response of Flyback Regulator of Figure 21, +15V Output

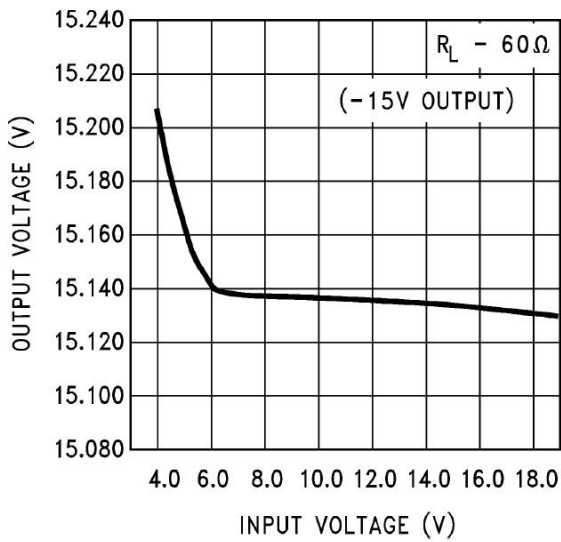

FIGURE 24. Line Regulation (Typical) of Flyback Regulator of Figure 21, -15V Output

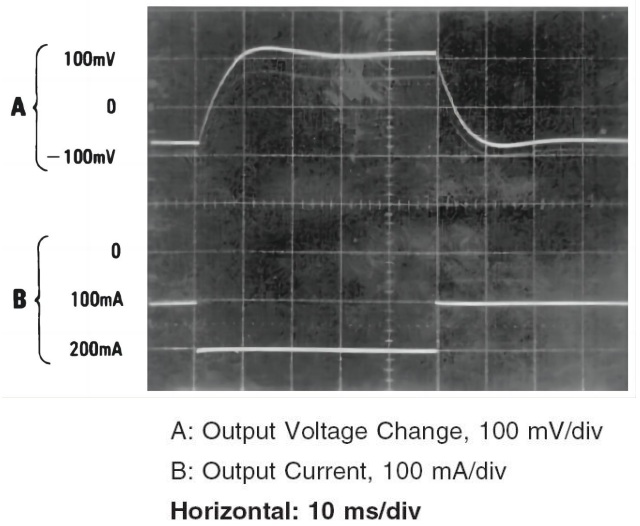
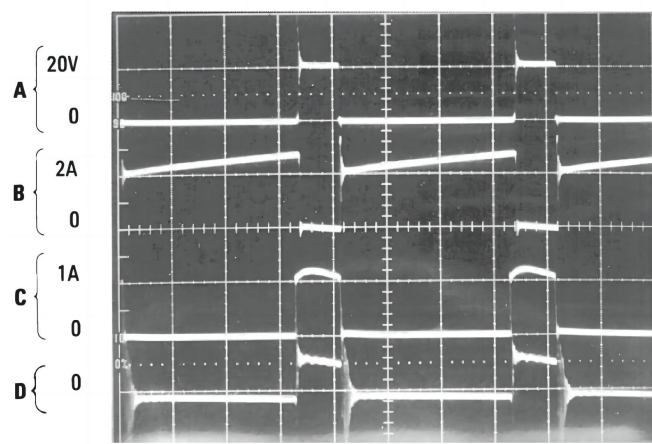

FIGURE 25. Load Transient Response of Flyback Regulator of Figure 21, -15V Output



A: Switch pin voltage, 20 V/div

B: Primary current, 2 A/div

C: +15V Secondary current, 1 A/div

D: +15V Output ripple voltage, 100 mV/div

Horizontal: 5 µs/div

FIGURE 26. Switching Waveforms of Flyback Regulator of Figure 21,
Each Output Loaded with 60

Package Information

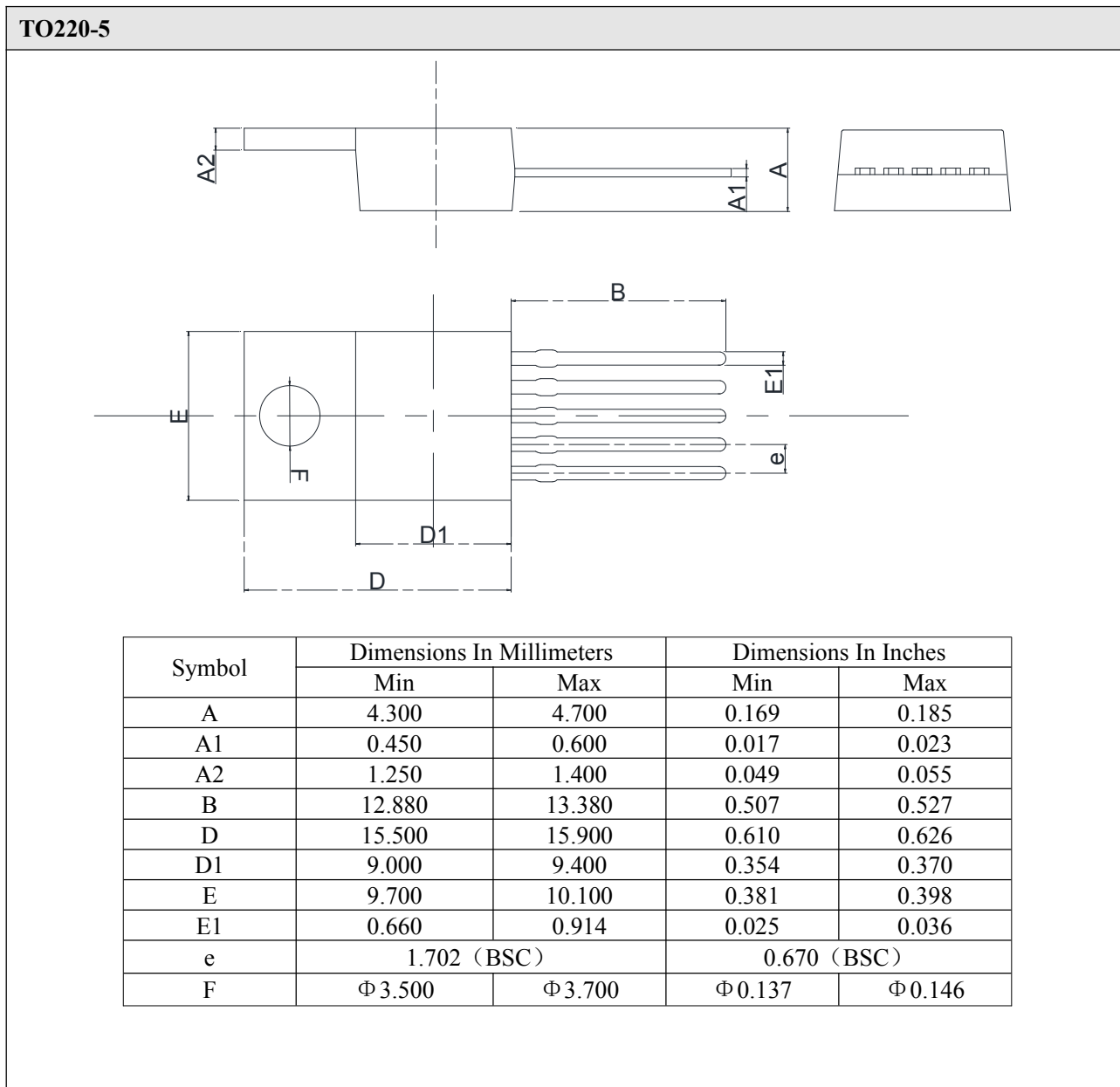

TO263-5

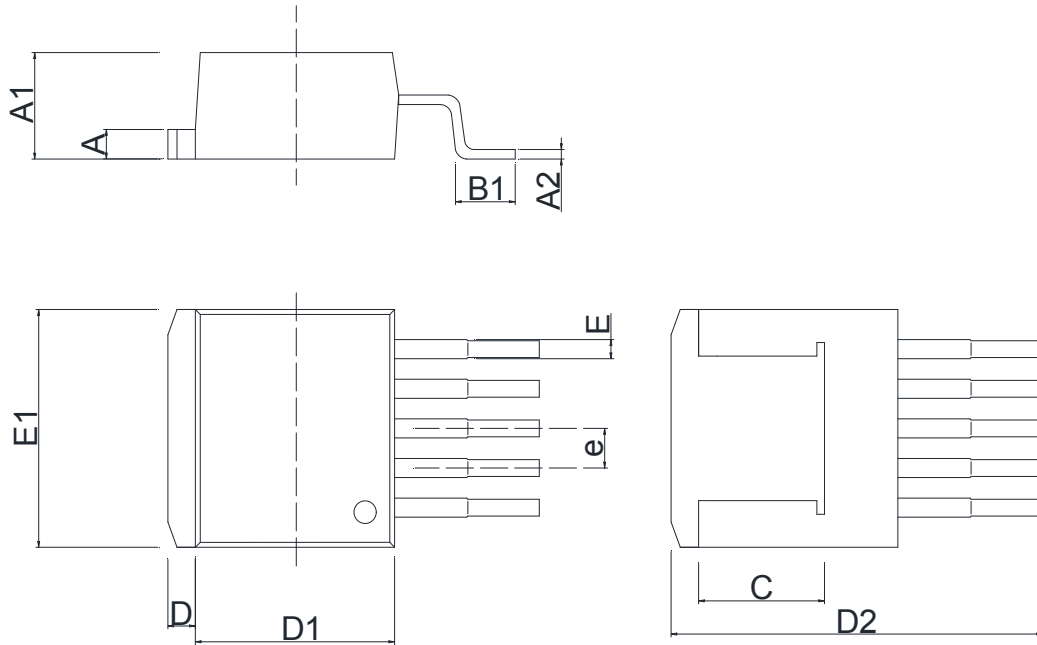

Symbol	Dimensions In Millimeters		Dimensions In Inches	
	Min	Max	Min	Max
A	1.170	1.370	0.046	0.054
A1	4.470	4.670	0.176	0.184
A2	0.310	0.530	0.012	0.021
B1	2.340	2.740	0.092	0.108
C	5.080 REF		0.200 REF	
D	1.170	1.370	0.046	0.054
D1	8.500	8.900	0.335	0.350
D2	14.550	15.550	0.572	0.612
E	0.660	0.860	0.025	0.034
E1	10.010	10.310	0.394	0.406
e	1.700 (BSC)		0.067 (BSC)	

Statement:

- XBLW reserves the right to modify the product manual without prior notice! Before placing an order, customers need to confirm whether the obtained information is the latest version and verify the completeness of the relevant information.
- Any semi-guide product is subject to failure or malfunction under specified conditions. It is the buyer's responsibility to comply with safety standards when using XBLW products for system design and whole machine manufacturing. And take the appropriate safety measures to avoid the potential in the risk of loss of personal injury or loss of property situation!
- XBLW product has not been licensed for life support, military and aerospace applications, and therefore XBLW is not responsible for any consequences arising from its use in these areas.
- If any or all XBLW products (including technical data, services) described or contained in this document are subject to any applicable local export control laws and regulations, they may not be exported without an export license from the relevant authorities in accordance with such laws.
- The specifications of any and all XBLW products described or contained in this document specify the performance, characteristics, and functionality of said products in their standalone state, but do not guarantee the performance, characteristics, and functionality of said products installed in Customer's products or equipment. In order to verify symptoms and conditions that cannot be evaluated in a standalone device, the Customer should ultimately evaluate and test the device installed in the Customer's product device.
- XBLW documentation is only allowed to be copied without any alteration of the content and with the relevant authorization. XBLW assumes no responsibility or liability for altered documents.
- XBLW is committed to becoming the preferred semiconductor brand for customers, and XBLW will strive to provide customers with better performance and better quality products.

X-ON Electronics

Largest Supplier of Electrical and Electronic Components

Click to view similar products for [Isolated DC/DC Converters](#) category:

Click to view products by [XBLW](#) manufacturer:

Other Similar products are found below :

[PSL486-7LR](#) [Q48T30020-NBB0](#) [18362](#) [JAHW100Y1](#) [SQ24S15033-PS0S](#) [CE-1004](#) [DFC15U48D15](#) [XGS-1205](#) [06322](#) [SPB05B-15](#)
[SQ48T10050-PDA0](#) [L-DA20](#) [DCG40-5G](#) [XKS-2405](#) [DPA423R](#) [VI-L53-CV](#) [24IBX15-50-0ZG](#) [HZZ01204-G](#) [SPU02N-09](#) [QUINT4-](#)
[BUFFER/24DC/40](#) [73-551-5039I](#) [AHV2815DF/HBB](#) [PAH-48/8.5-D48NB1-C](#) [QRS2050P025K00](#) [CM2320-9EG](#) [SKMW15F-05](#) [TEN 12-](#)
[2413](#) [TEQ 100-2418WIR](#) [TEQ 160-7218WIR](#) [TSV 1212S](#) [HQA2W085W033V-N07-S](#) [LT8301ES5#WTRPBF](#) [UC2842N](#) [SY8368AQQC](#)
[AOZ2261AQI-18](#) [B0509XT-1WR3](#) [B0503XT-1WR3](#) [VRB2405S-10WR3](#) [B0515XT-1WR3](#) [EA8103DHR](#) [VRB2424S-10WR3](#) [B0512XT-](#)
[1WR3](#) [B0524XT-1WR3](#) [AM40UW-2412SZ](#) [AM10CW-2412D-NZ-STD](#) [AOZ2260AQI-15](#) [B0303XT-1WR3](#) [AOZ2151EQI-30](#)
[AOZ2152EQI-30](#) [AOZ2254EQI-30](#)