



# ProSig Wi-Fi 6E Tri-Band Directional Antennas

## 2x2 and 4x4 MIMO Panel Antennas 2.4-2.5, 4.9-6.0 & 6.0-7.125 GHz

ProSig 2.4-2.5, 5.15-6.0, 6.0-7.125 GHz tri-band directional array panel antennas are specially designed to complement interior or exterior mounted Wi-Fi 6E wireless network systems.

The antennas are supplied with integrated RG58LL plenum-rated cables with RP-SMA connectors for ease of installation.

The supplied mounting bracket allows for either pole/mast mounting or direct wall mount configurations.

### FEATURES AND BENEFITS

- Tri-Band Wi-Fi coverage including legacy Wi-Fi, Wi-Fi 6, Wi-Fi 6E and Wi-Fi 7
- 2x2 and 4x4 MIMO options
- High performance beam pattern
- Pole/mast and wall mountable with supplied mounting hardware

### APPLICATIONS

- WLAN
- Wi-Fi - Wi-Fi 7 (802.11be), Wi-Fi 6E (802.11ax), Wi-Fi 6 (802.11ax), Wi-Fi 5 (802.11ac), Wi-Fi 4 (802.11n), 802.11b/g
- Automation and control
- Outdoor and indoor applications

### SPECIFICATIONS

ELECTRICAL SPECIFICATION			
Operating Frequency (MHz)	2400-2500	5150-5900	6000-7125
Peak Gain Max (dBi)	8.3	8.9	9.4
Total Efficiency Average (%)	>70	>60	>50
Average 3 dB Beamwidth (°) Azimuth	73	58	53
Average 3 dB Beamwidth (°) Elevation	56	63	52
Port Isolation dB	-20		
VSWR - Max	<2.0:1		
Nominal Impedance (Ohms)	50		
Max Power - Ambient 25°C (W)	2		
Polarization	Linear, Dual-Slant ±45°/ ±135°		

## VSWR

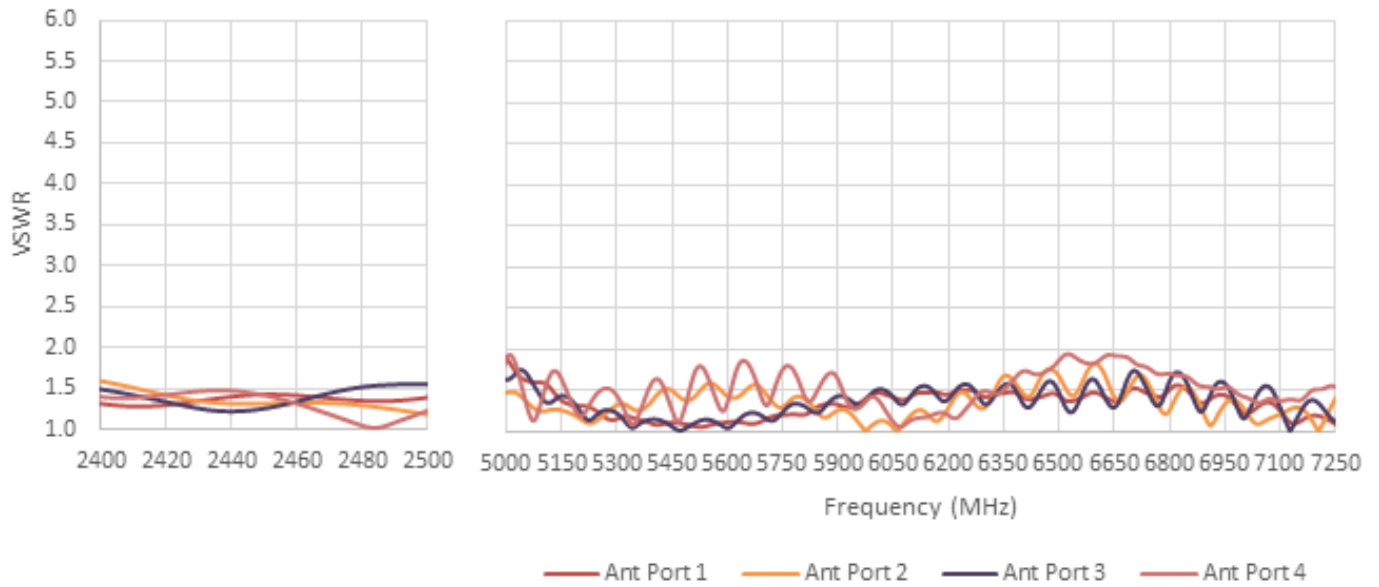

## ISOLATION

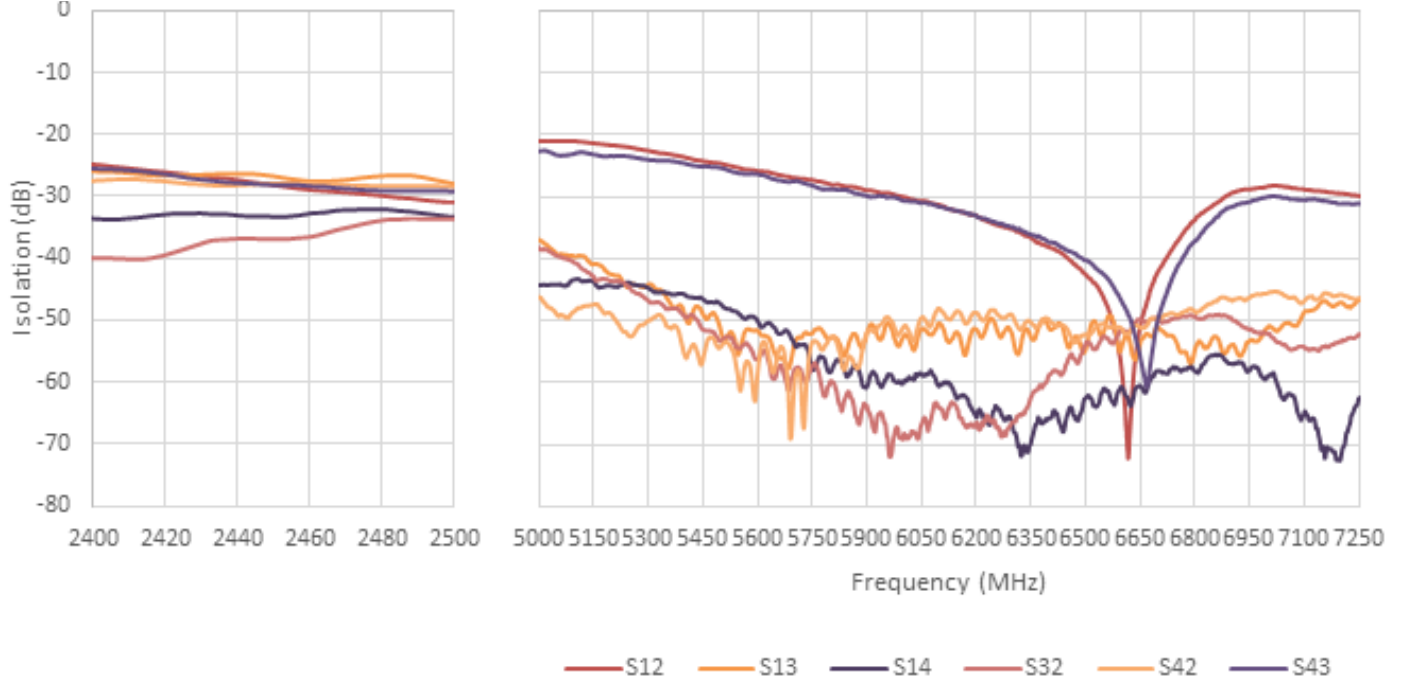

## EFFICIENCY

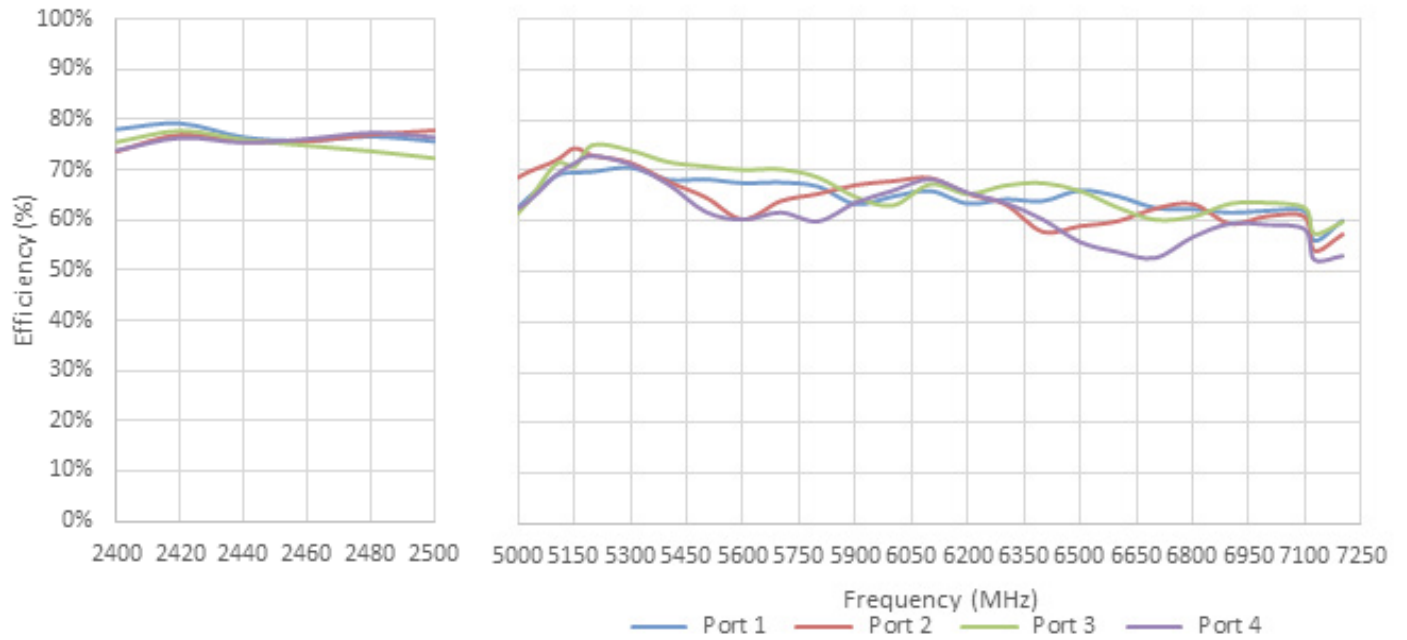

## GAIN

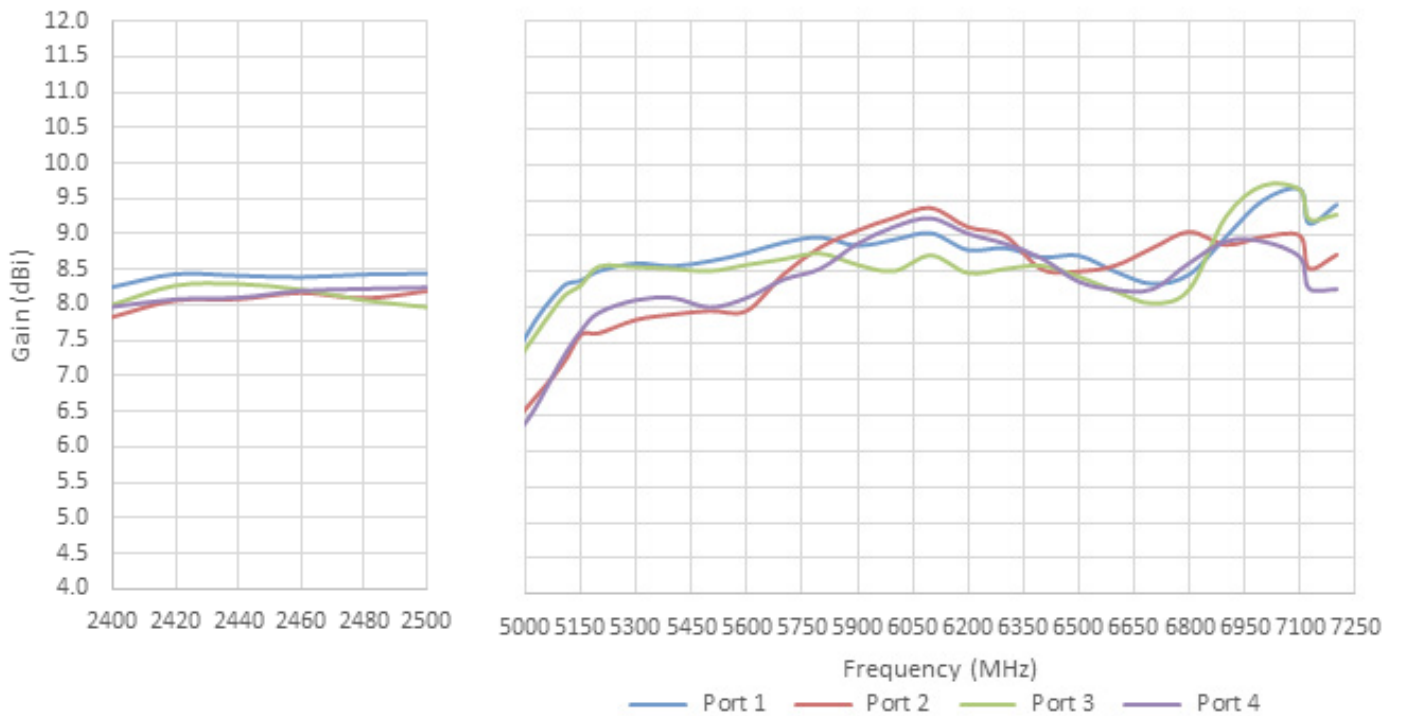

## MECHANICAL SPECIFICATION

Dimensions - L x W x H - mm (in.)	200 x 200 x 46.5 (7.87 x 7.87 x 1.83)
Weight - kg (lbs.)	2-Port - 0.43 (0.95) 4-Port - 0.54 (1.19)
Radome	ASA, Luran S 788T, UV (White)
Cable	750±15 mm PLENUM RATED RG58LL
Connector	RP-SMA
Ingress Protection	IP67
Wind Loading mph (kph)	135 (217)
Vibration	IEC 60068-2-64 (Vibration, broad-band random)
Shock	IEC 60068-2-27
Earthquake	IEC 60068-2-6 [Fc]
Drop Test - Radome	Drop freely from a height of 1m, 5 times, 1 drop per side
Pull Test - Cable	20lbs straight pull with antenna held fixed

## ENVIRONMENTAL SPECIFICATION

Operating Temperature - °C (°F)	-50 to +70°C (-58 to +149°F)
Storage Temperature - °C (°F)	-50 to +85°C (-58 to +149°F)
Material Substance Compliance	RoHS Compliant CE & UKCA

## PART NUMBER CONFIGURATIONS

PART NUMBER	PIGTAIL/CABLE	CONNECTOR	NUMBER PORTS
L000962-01	750 ± 15 mm / Plenum Rated RG58LL	2 x RP-SMA Male	2
L000962-02	750 ± 15 mm / Plenum Rated RG58LL	4 x RP-SMA Male	4

## MECHANICAL DRAWINGS

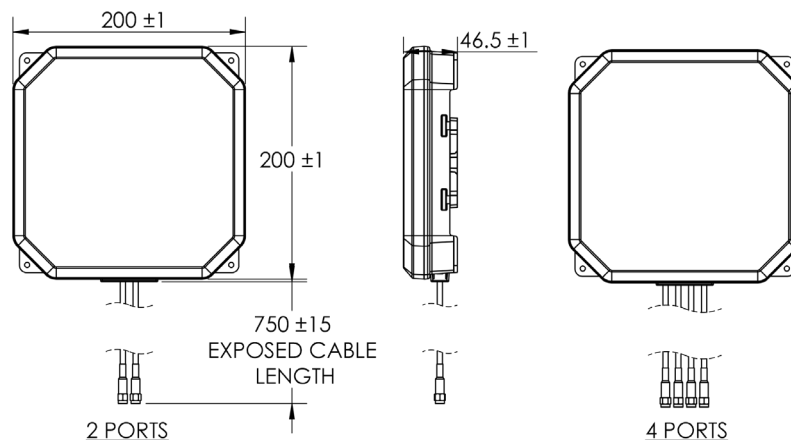

## MOUNTING OPTIONS USING SUPPLIED HARDWARE

### WALL MOUNT

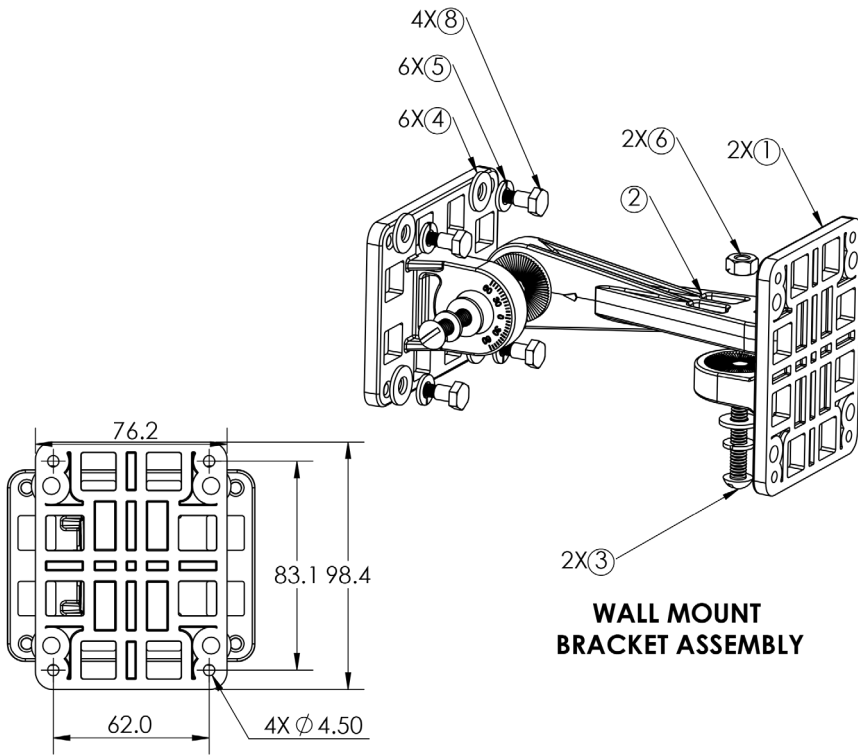

### POLE/MAST MOUNT

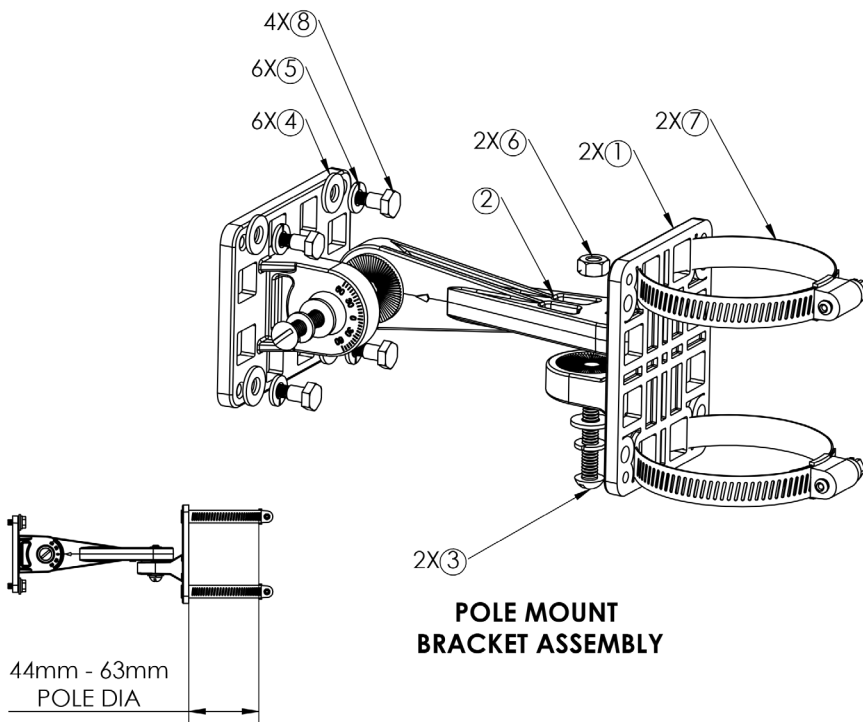

## RADIATION PATTERNS - PORT 1

### Radiation Patterns at 2.4 GHz Band

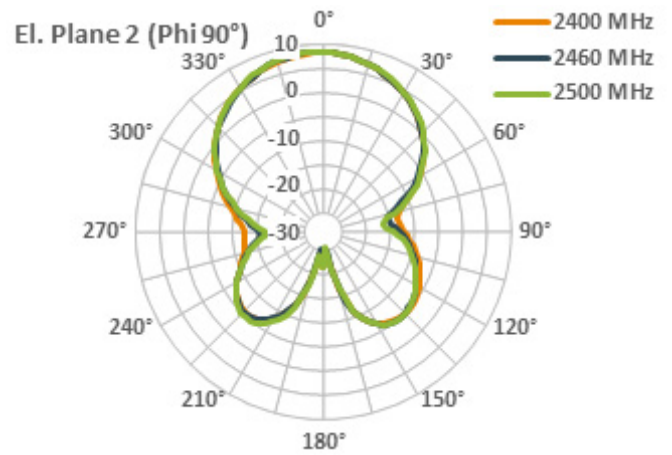
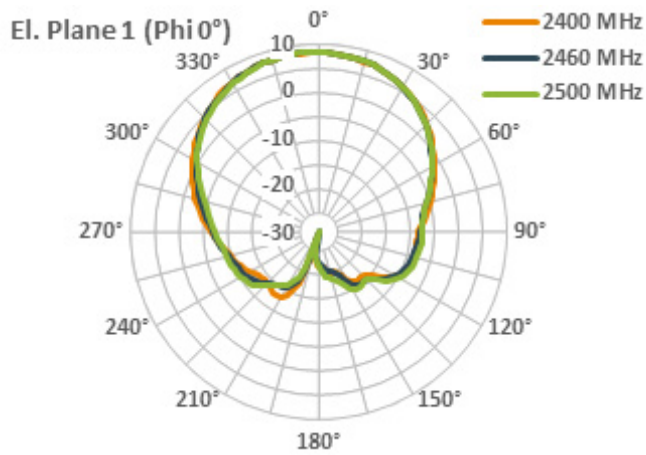

### Radiation Patterns at 5 GHz Band

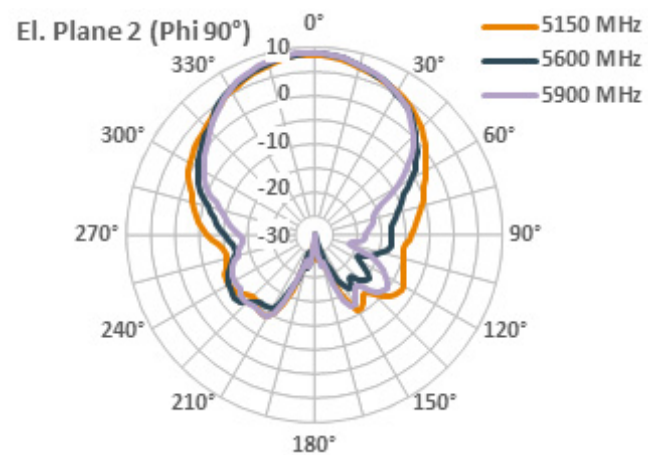
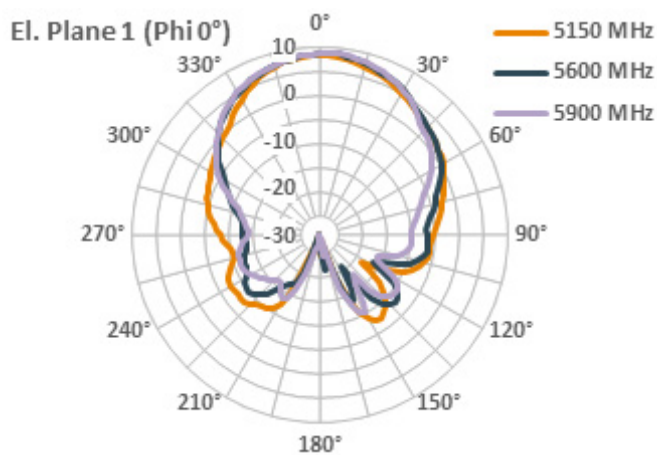

### Radiation Patterns at 6 GHz Band

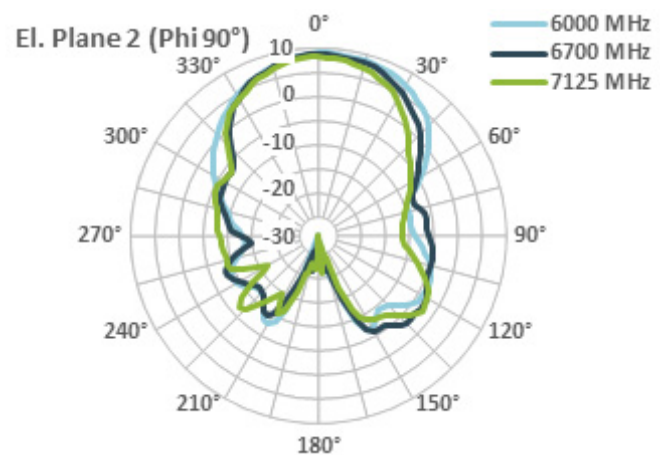
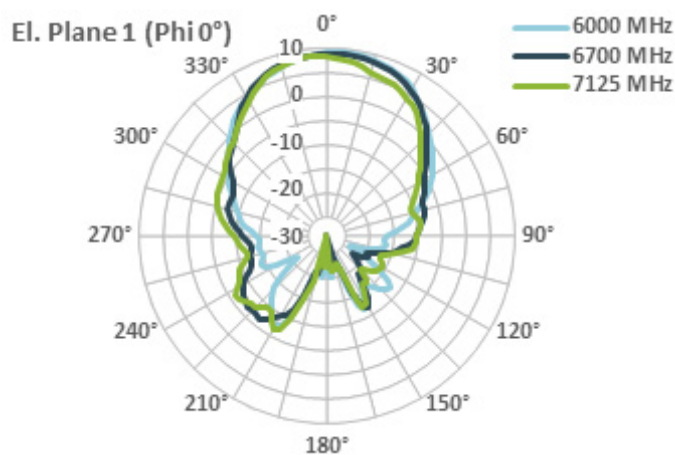

## RADIATION PATTERNS - PORT 2

### Radiation Patterns at 2.4 GHz Band

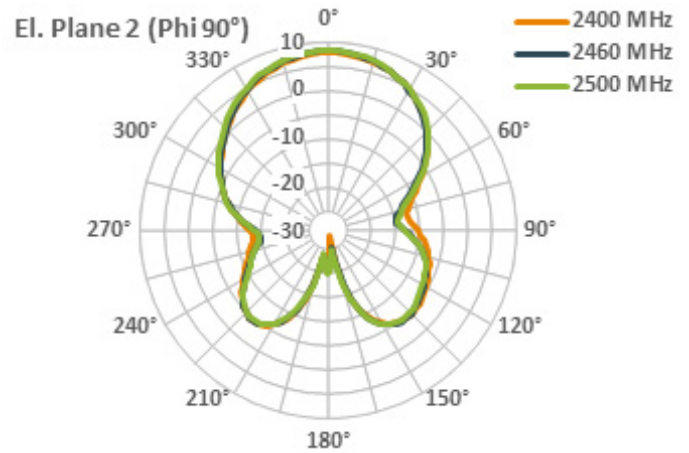
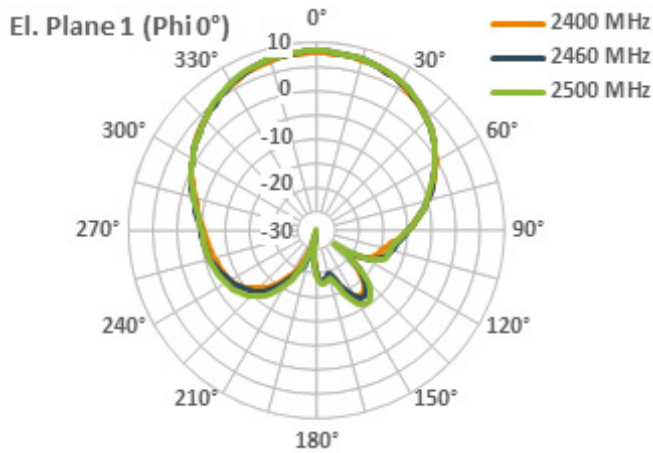

### Radiation Patterns at 5 GHz Band

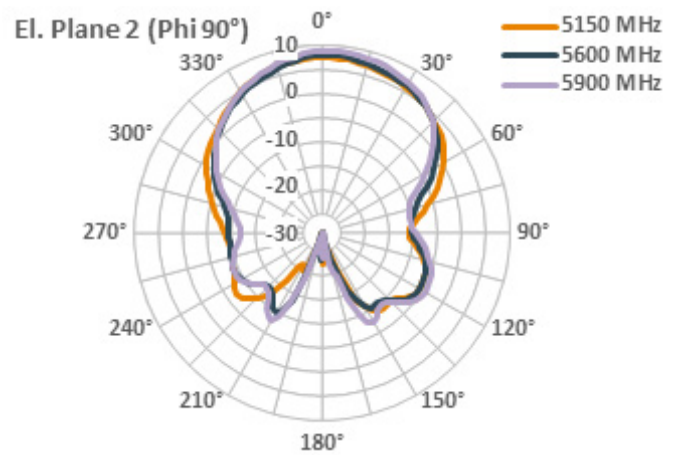
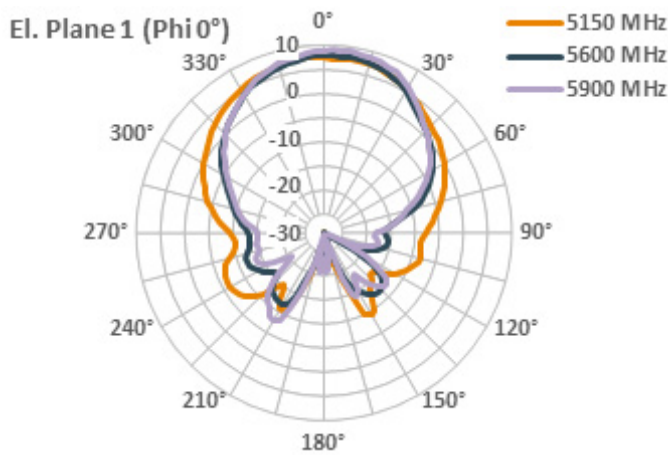

### Radiation Patterns at 6 GHz Band

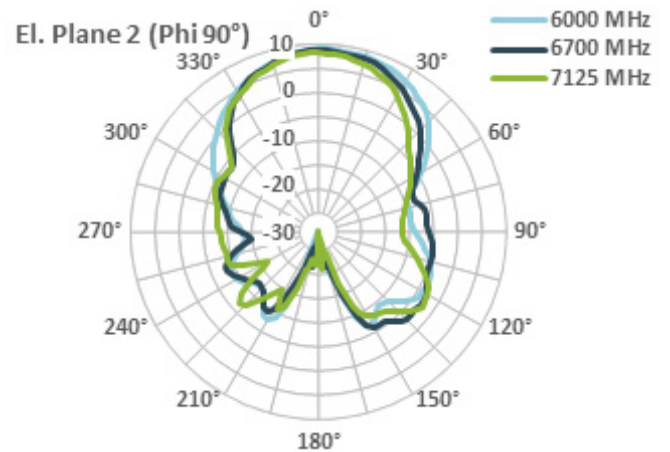
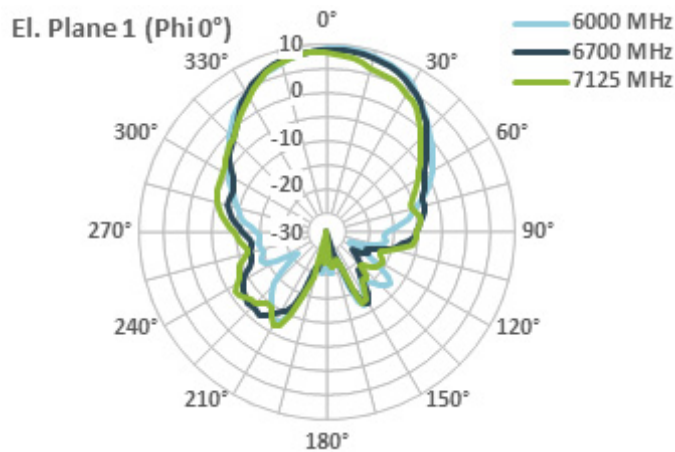

## RADIATION PATTERNS - PORT 3

### Radiation Patterns at 2.4 GHz Band

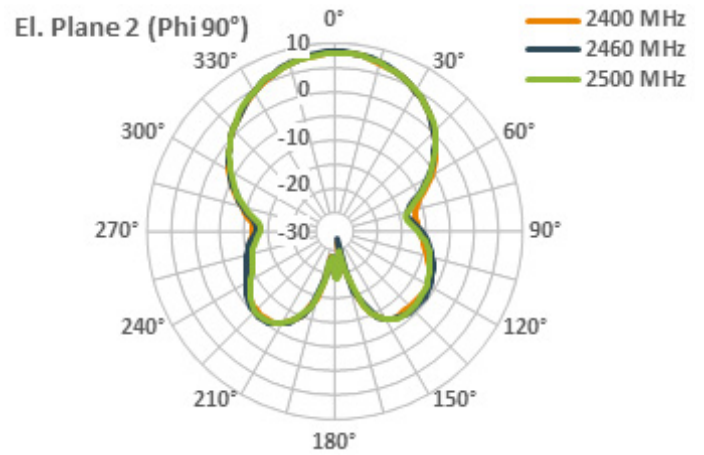
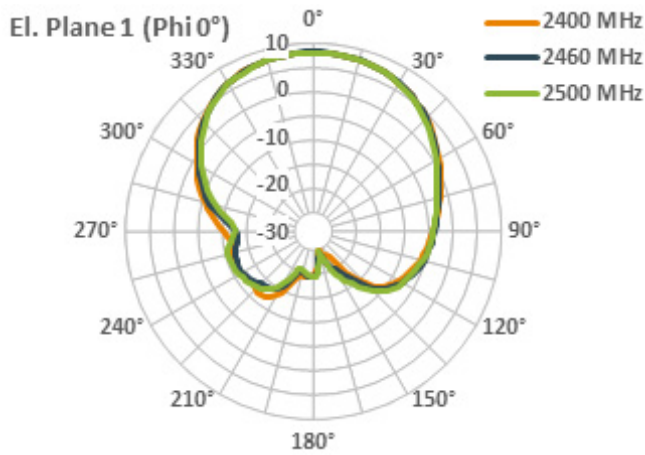

### Radiation Patterns at 5 GHz Band

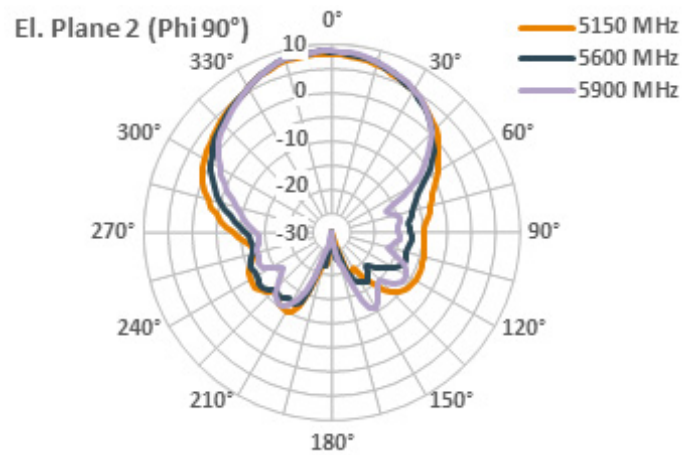
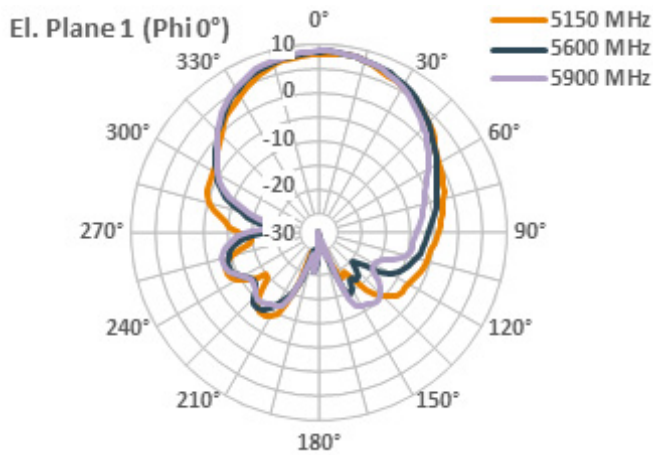

### Radiation Patterns at 6 GHz Band

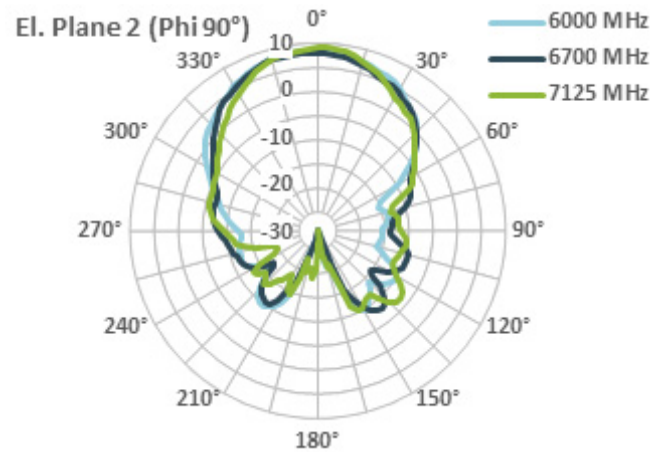
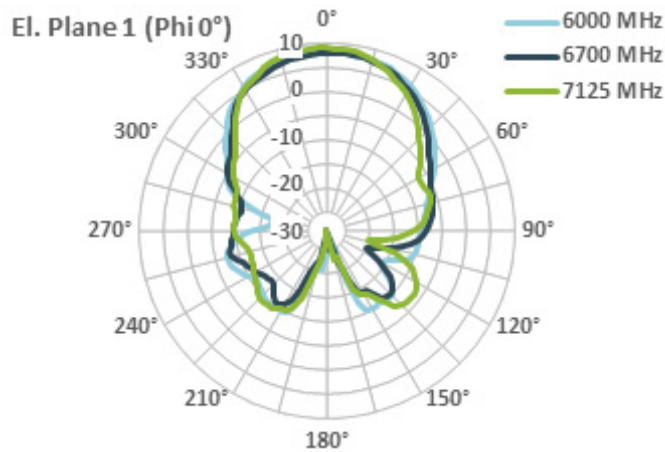

## RADIATION PATTERNS - PORT 4

### Radiation Patterns at 2.4 GHz Band

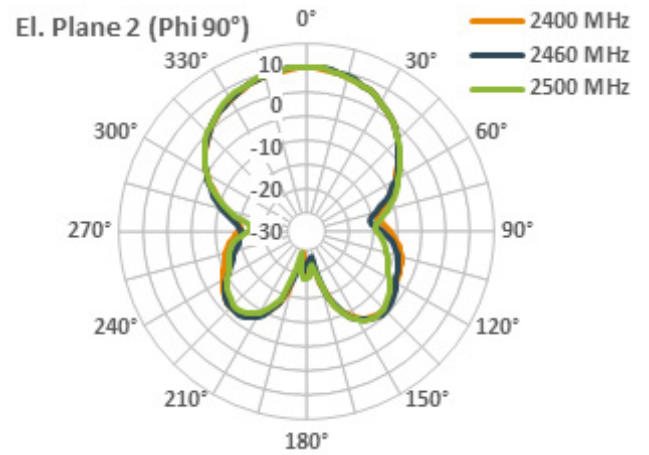
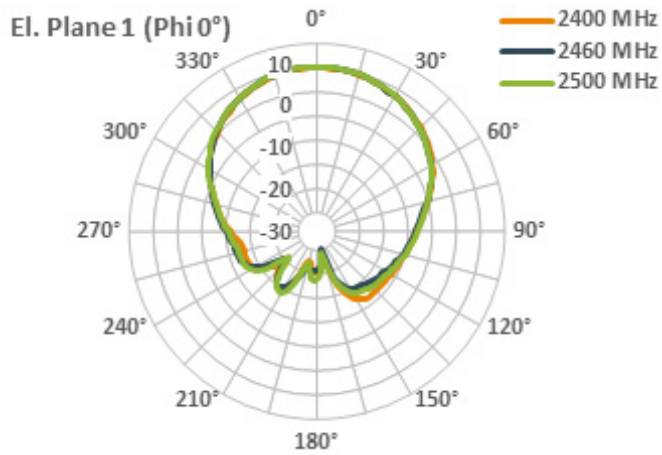

### Radiation Patterns at 5 GHz Band

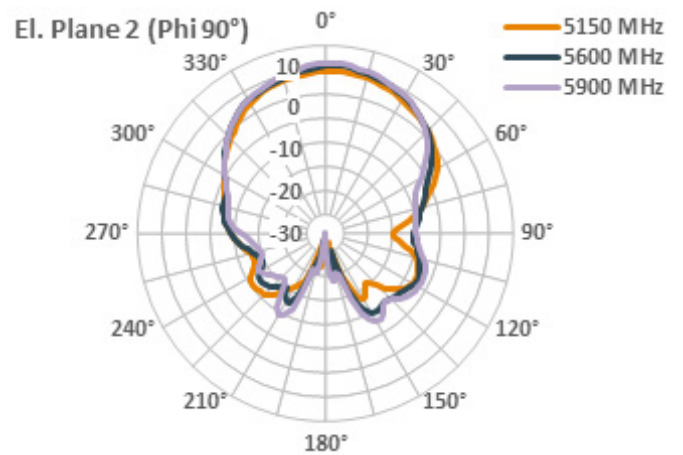
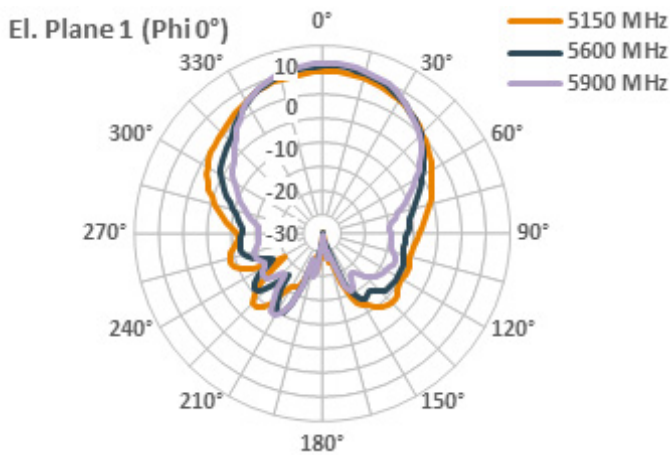

### Radiation Patterns at 6 GHz Band

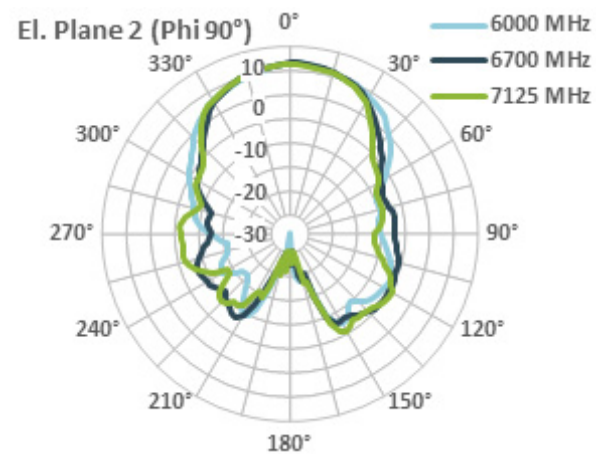
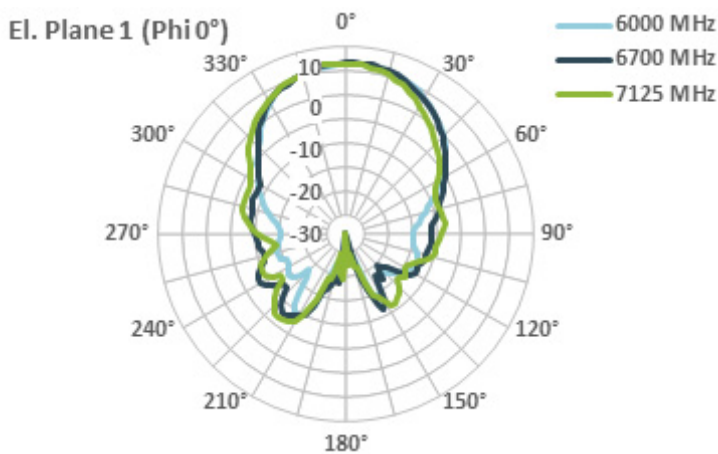

## PACKING INFORMATION

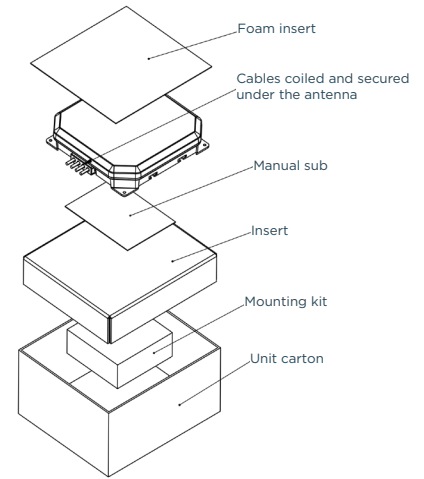
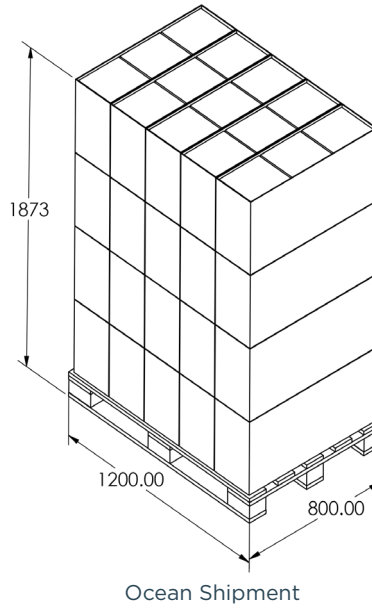
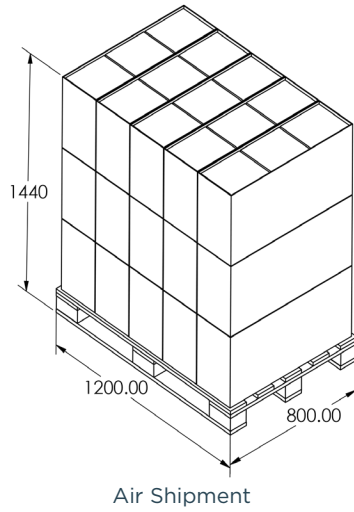

PACKAGED DIMENSIONS	Unit Carton	MASTER CARTON	AIR PALLET	OCEAN PALLET
Number of Antennas	1	9	135	180
Height mm (in)	13.4 (5.3)	43.0 (16.9)	144.0 (56.7)	187.3 (73.7)
Length mm (in)	24.4 (9.6)	77.0 (30.3)	120.0 (47.2)	120.0 (47.2)
Width mm (in)	21.4 (8.4)	23.0 (9.1)	80.0 (31.5)	80.0 (31.5)
Est. Shipping Weight kg (lbs.)	0.8 (1.8)	7.2 (15.9)	108.0 (238.1)	144.0 (317.5)

### TE TECHNICAL SUPPORT CENTER

USA:	+1 (800) 522-6752
Canada:	+1 (905) 475-6222
Mexico:	+52 (0) 55-1106-0800
Latin/S. America:	+54 (0) 11-4733-2200
Germany:	+49 (0) 6251-133-1999
UK:	+44 (0) 800-267666
France:	+33 (0) 1-3420-8686
Netherlands:	+31 (0) 73-6246-999
China:	+86 (0) 400-820-6015

### te.com

TE, TE Connectivity, TE connectivity (logo), and EVERY CONNECTION COUNTS are trademarks owned or licensed by the TE Connectivity plc family of companies. Other product names, logos, and company names mentioned herein may be trademarks of their respective owners.

The information given herein, including drawings, illustrations and schematics which are intended for illustration purposes only, is believed to be reliable. However, TE Connectivity makes no warranties as to its accuracy or completeness and disclaims any liability in connection with its use. TE Connectivity's obligations shall only be as set forth in TE Connectivity's Standard Terms and Conditions of Sale for this product and in no case will TE Connectivity be liable for any incidental, indirect or consequential damages arising out of the sale, resale, use or misuse of the product. Users of TE Connectivity products should make their own evaluation to determine the suitability of each such product for the specific application.

©2024 TE Connectivity. All Rights Reserved.

10/24 Original

## X-ON Electronics

Largest Supplier of Electrical and Electronic Components

*Click to view similar products for [Antennas](#) category:*

*Click to view products by [TE Connectivity](#) manufacturer:*

Other Similar products are found below :

[930-033-R](#) [EXE902SM](#) [108-00014-50](#) [66089-2406](#) [A09-F8NF-M](#) [A09-F5NF-M](#) [RGFRA1903041A1T](#) [W1049B090](#) [TRABT1560](#)  
[WTL2449CQ1-FRSMM](#) [CPL9C](#) [CB27S](#) [0600-00060](#) [Y4503](#) [PAL90209H-FNF](#) [GD53-25](#) [MAF94051](#) [S9025PLSMF](#) [QWFTB120](#)  
[MAF94300](#) [FG4403](#) [BB1442NR](#) [GPSCPMM00](#) [ANTDOM-05-01-WPM](#) [ANT-WP868SMA-Y](#) [EXW30BNX](#) [S4908WBFNM](#) [B4305CN](#)  
[C27](#) [C27S](#) [CBNC58](#) [EXH160MXI](#) [EXH160SFK](#) [EXC902SM](#) [CB27](#) [ABFT](#) [BB4502NR](#) [B4502N](#) [S4908WBFNF](#) [NMOQ88C](#) [NMOQB](#)  
[NMOQC](#) [ANT-GSMGPSPUKS](#) [60210](#) [60140](#) [ANT-8WPIG-UFL](#) [ANT-GPSPUKS](#) [A21H0](#) [29000863](#) [29000848](#)