



TAOGLAS®



Datasheet

Raptor Max

Part No:
MAX1012.A.001

Description

12-in-1 Permanent Mount Antenna with Multiband GNSS, 8 5G/4G,
3 Wi-Fi with Staggered RG-174/TGC-1.5DS Cables

Features:

- Low-profile, IP67 rated Enclosure
- 8* 5G/4G MIMO 617~6000MHz
- 3* WIFI MIMO 2.4/5.8/7.125GHz
- 1* GNSS L1/L5 Dual-band Antenna
- Cables: RG-174 for GNSS, TGC-1.5DS for 4G-5G and Wi-Fi
- Connectors: SMA(M) / RP-SMA(M)
- Dims: 330mm x 75.5mm x 45.2mm
- RoHS & Reach Compliant

1.	Introduction	3
2.	Specification	5
3.	Mechanical Drawing	9
4.	Packaging	10
5.	Installation Guide	11
6.	Characteristics	12
7.	LNA Characteristics	22
8.	Radiation Patterns	27
<hr/>		
	Changelog	143

Taoglas makes no warranties based on the accuracy or completeness of the contents of this document and reserves the right to make changes to specifications and product descriptions at any time without notice. Taoglas reserves all rights to this document and the information contained herein. Reproduction, use or disclosure to third parties without express permission is strictly prohibited.

Ireland & USA
ISO 9001:2015
Certified



Taiwan
ISO 9001:2015
Certified



1. Introduction



The Taoglas® Raptor MAX series combination antenna is designed to enhance the connectivity options available to you for your vehicle. With up to 16-in-1 connections available, in combinations of Multiband GNSS, 5G/4G MIMO, Wi-Fi MIMO, and LMR/VHF/UHF/Tetra, this next generation, super low-profile vehicle roof mount antenna eliminates the need for multiple antennas, saving you time and money on installations.

The MAX1012 version combines multiband GNSS (L1/L5), 8 5G/4G antennas, and 3 Wi-Fi antennas. The super low profile, fully IP67 rated waterproof enclosure is manufactured from a robust, IK08 rated, UV protected ABS material, ideal for use in any environment or weather condition. Combining all the antennas for your application into one compact enclosure saves on installation space, reduces costs and allows for multi network support.

Typical application for the Raptor MAX series of products include:

- **Connected Vehicles** – Fleet Management and Asset Tracking
- **Smart Cities** – Public Safety Systems and Infrastructure
- **Industrial IoT** – Monitoring and Asset Tracking
- **Public Safety** – First Responder Vehicles
- **Military and Defense** – Command and Control Systems

The antenna comes with RG-174 and low-loss TGC-1.5DS coaxial pigtail cables as standard, terminating in SMA(M) / RP-SMA(M), with custom configurations available depending on your requirements. Cable extension kits are available and are fully customized to suit your application. Several configurations of the Raptor MAX Series will launch as standard, see below, but other configurations are available upon request, available in both black and white and with or without braided cables. Contact your local Taoglas customer service team for more information.

Raptor Max Series Configurations:

- **MAX1008** 8x 5G/4G
- **MAX1009** 1x GNSS and 8x 5G/4G
- **MAX1012** 1x GNSS, 8x 5G/4G and 3x Wi-Fi
- **MAX1013** 1x GNSS, 8x 5G/4G and 4x Wi-Fi
- **MAX1014** 1x GNSS, 8x 5G/4G and 5x Wi-Fi
- **MAX1015** 1x GNSS, 8x 5G/4G and 6x Wi-Fi
- **MAX1016** 1x GNSS, 8x 5G/4G, 6x Wi-Fi and 1x LMR Whip



2. Specification

GNSS Frequency Bands					
GPS	L1 1575.42 MHz	L2 1227.6 MHz	L5 1176.45 MHz		
	■	□	■		
GLONASS	G1 1602 MHz	G2 1248 MHz	G3 1207 MHz		
	□	□	□		
Galileo	E1 1575.24 MHz	E5a 1176.45 MHz	E5b 1201.5 MHz	E6 1278.75 MHz	
	■	■	□	□	
BeiDou	B1C 1575.42 MHz	B1I 1561 MHz	B2a 1176.45 MHz	B2b 1207.14 MHz	B3 1268.52 MHz
	■	■	■	□	□
L-Band	L-Band 1542 MHz				
	□				
QZSS (Regional)	L1 1575.42 MHz	L2C 1227.6 MHz	L5 1176.45 MHz	L6 1278.75e6	
	■	□	■	□	
IRNSS (Regional)	L5 1176.45 MHz				
	■				
SBAS	L1/E1/B1 1575.42 MHz	L5/B2a/E5a 1176.45 MHz	G1 1602 MHz	G2 1248 MHz	G3 1207 MHz
	■	■	□	□	□

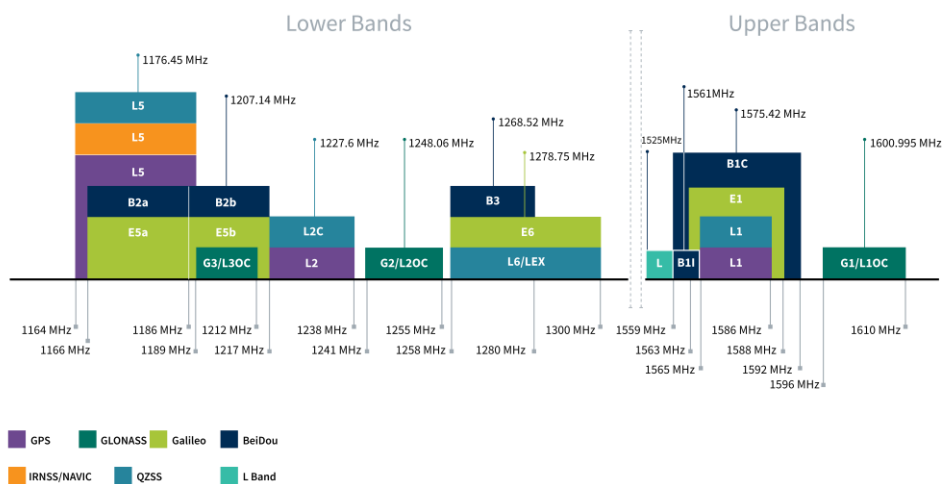

GNSS Bands and Constellations

Passive GNSS Electrical			
Frequency (MHz)	1176.45	1561	1575.42
VSWR (max.)	3:1	3:1	3:1
Passive Antenna Efficiency (%)	37.77	33.44	40.65
Passive Antenna Gain at Zenith (dBi)	1.75	3.59	4.51
Polarization	Linear		
Impedance	50 Ω		

LNA and Electrical Properties				
Frequency (MHz)	1176.45	1561	1575.42	1602
Gain(dB)	29.7	28.8	28.1	28.6
Noise Figure (dB)	2.9	2.8	2.9	2.3
Input Voltage (V)	+ 1.8 to 5.5			
Current consumption (mA)	5 ± 2			
IEC61000-4-2 (ESD protection)	± 30 kV air / ± 20Kv contact discharge			

4G-5G Electrical									
Band	Frequency (MHz)	Antenna MIMO	Efficiency (%)	Average Gain (dB)	Peak Gain (dBi)	Impedance	Polarization	Radiation Pattern	Max. input power
5GNR/4G Band71	617-698	4G-5G 1	27.0	-5.69	2.03	50 Ω	Linear	Omni	10W
		4G-5G 2	20.4	-6.91	-1.50				
		4G-5G 3	25.6	-5.92	0.17				
		4G-5G 4	44.1	-3.56	3.54				
		4G-5G 5	24.9	-6.04	2.68				
		4G-5G 6	24.5	-6.11	-0.41				
		4G-5G 7	25.1	-6.00	-1.18				
		4G-5G 8	29.9	-5.24	0.85				
4G/3G Band 12,13,14,17,28,29	698-824	4G-5G 1	34.1	-4.67	2.63	50 Ω	Linear	Omni	10W
		4G-5G 2	32.0	-4.95	1.92				
		4G-5G 3	35.7	-4.48	2.67				
		4G-5G 4	42.9	-3.67	2.75				
		4G-5G 5	32.0	-4.95	1.77				
		4G-5G 6	26.4	-5.79	-0.11				
		4G-5G 7	32.9	-4.83	1.97				
		4G-5G 8	36.4	-4.39	2.24				
4G/3G/NB-IoT/Cat M Band 5,8,18,19,20,26,27	824-960	4G-5G 1	38.3	-4.16	1.52	50 Ω	Linear	Omni	10W
		4G-5G 2	36.0	-4.44	1.50				
		4G-5G 3	28.3	-5.48	1.20				
		4G-5G 4	35.5	-4.49	2.45				
		4G-5G 5	29.9	-5.24	1.53				
		4G-5G 6	28.7	-5.43	-0.35				
		4G-5G 7	36.3	-4.40	2.66				
		4G-5G 8	40.1	-3.97	2.58				
5GNR/4G Band 21,32,74,75,76	1427-1518	4G-5G 1	37.4	-4.27	2.73	50 Ω	Linear	Omni	10W
		4G-5G 2	41.9	-3.78	3.32				
		4G-5G 3	33.1	-4.81	2.78				
		4G-5G 4	32.9	-4.82	2.33				
		4G-5G 5	31.2	-5.06	2.10				
		4G-5G 6	31.5	-5.01	1.43				
		4G-5G 7	39.7	-4.02	2.25				
		4G-5G 8	25.7	-5.91	0.94				
4G/3G Band 1,2,3,4,9,23,25,35,39,66	1710-2200	4G-5G 1	46.4	-3.34	4.93	50 Ω	Linear	Omni	10W
		4G-5G 2	47.2	-3.26	4.61				
		4G-5G 3	51.5	-2.88	5.48				
		4G-5G 4	48.7	-3.13	5.34				
		4G-5G 5	51.5	-2.88	6.07				
		4G-5G 6	49.3	-3.07	6.07				
		4G-5G 7	29.8	-5.26	4.22				
		4G-5G 8	31.3	-5.04	2.93				
4G/3G Band 7,30,38,40,41	2300-2690	4G-5G 1	49.9	-3.02	5.47	50 Ω	Linear	Omni	10W
		4G-5G 2	48.3	-3.16	4.39				
		4G-5G 3	48.2	-3.17	6.12				
		4G-5G 4	38.8	-4.12	6.69				
		4G-5G 5	39.2	-4.07	5.96				
		4G-5G 6	49.2	-3.08	6.79				
		4G-5G 7	39.7	-4.01	5.28				
		4G-5G 8	43.1	-3.65	6.09				
5GNR/4G Band 22,42,48,77,78,79	3300-5000	4G-5G 1	51.4	-2.89	6.13	50 Ω	Linear	Omni	10W
		4G-5G 2	44.9	-3.48	7.46				
		4G-5G 3	47.4	-3.24	5.75				
		4G-5G 4	48.2	-3.17	6.88				
		4G-5G 5	42.5	-3.72	5.24				
		4G-5G 6	46.2	-3.35	5.90				
		4G-5G 7	43.1	-3.65	5.37				
		4G-5G 8	46.1	-3.36	6.02				
4G-5G 5200/Wi-Fi5800	5150-5925	4G-5G 1	43.2	-3.65	7.96	50 Ω	Linear	Omni	10W
		4G-5G 2	42.7	-3.69	7.82				
		4G-5G 3	43.4	-3.63	5.67				
		4G-5G 4	46.5	-3.33	5.73				
		4G-5G 5	42.7	-3.70	5.26				
		4G-5G 6	43.6	-3.61	5.84				
		4G-5G 7	40.1	-3.97	6.03				
		4G-5G 8	44.6	-3.50	6.14				

Wi-Fi Electrical									
Band	Frequency (MHz)	Antenna MIMO	Efficiency (%)	Average Gain (dB)	Peak Gain (dBi)	Impedance	Polarization	Radiation Pattern	Max. input power
Wi-Fi – 2GHz	2400-2500	Wi-Fi1	56.5	-2.48	4.36	50 Ω	Linear	Omni	10W
		Wi-Fi2	58.2	-2.35	6.55				
		Wi-Fi3	56.1	-2.51	5.68				
Wi-Fi - 5GHz	5150-5850	Wi-Fi1	49.3	-3.07	5.71				
		Wi-Fi2	49.5	-3.05	7.47				
		Wi-Fi3	47.8	-3.20	5.63				
Wi-Fi - 6GHz	5925-7125	Wi-Fi1	47.1	-3.27	6.33				
		Wi-Fi2	49.9	-3.02	7.47				
		Wi-Fi3	48.4	-3.15	6.28				

Mechanical	
Dimensions	330 x 75.5 x 45.2mm
Material	PC
Connector	SMA(M) and RP-SMA(M) - See Page 8 for more details
Cable	RG-174 and TGC-1.5DS - See Page 8 for more details
IK Impact Rating	IK08 – 5 Joules / 1.7Kg dropped from 300mm

Environmental	
Temperature Range	-40 - +85°C
Relative Humidity	Non-condensing 65°C 95% RH
Ingress Protection	IP67
RoHS & REACH Compliant	Yes

3. Mechanical Drawing

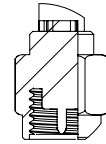
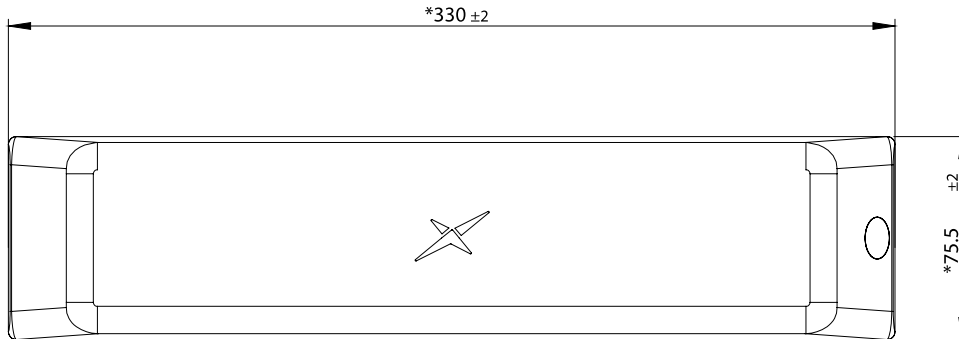

DETAIL A
SCALE 1.5 : 1

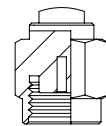
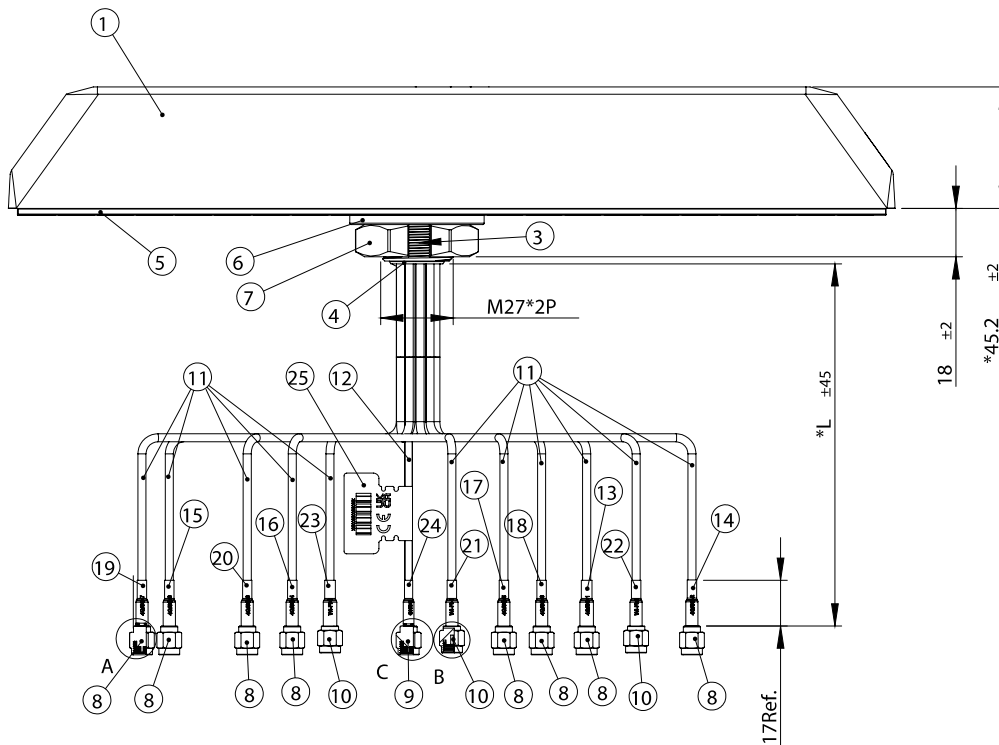

DETAIL B
SCALE 1.5 : 1

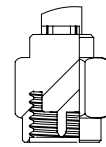

DETAIL C
SCALE 1.5 : 1

Name	Material	Finish	Qty
1 Top housing	PC	MT9050, Black	1
2 Bottom housing	PC+10%GF	MT9050, Black	1
3 Metal Stem	Zinc Alloy	Ni Plated	1
4 Grommet	Silicone Rubber	Black	1
5 Double Side Adhesive	3M 9448HK + CR4305 2t	Black	1
6 washer(ID28*OD50 t4.0)	S35C	Ni-Zn Plated	1
7 M27*P2.0mm steel Nut	S35C	Ni-Zn Plated	1
8 SMA(M)ST Plug for low loss1.5DS	Brass	Au Plated	8
9 SMA(M)ST Plug _for RG-316/RG-174	Brass	Au Plated	1
10 SMA(M)ST_RP low loss 1.5DS	Brass	AU PLATING	3
11 TGC-1.5DS Coaxial Cable	PE	Black	11
12 RG174 Coaxial Cable	PE	Black	1
14 Heat Shrink Tube(4G/5G-1)	PE	Red Tube/White Text	1

Name	Material	Finish	Qty
14 Heat Shrink Tube(4G/5G-2)	PE	Red Tube/White Text	1
15 Heat Shrink Tube(4G/5G-3)	PE	Red Tube/White Text	1
16 Heat Shrink Tube(4G/5G-4)	PE	Red Tube/White Text	1
17 Heat Shrink Tube(4G/5G-5)	PE	Red Tube/White Text	1
18 Heat Shrink Tube(4G/5G-6)	PE	Red Tube/White Text	1
19 Heat Shrink Tube(4G/5G-7)	PE	Red Tube/White Text	1
20 Heat Shrink Tube(4G/5G-8)	PE	Red Tube/White Text	1
21 Heat Shrink Tube (WiFi-1)	PE	Yellow tube/ Black text	1
22 Heat Shrink Tube (WiFi-2)	PE	Yellow Tube/Black Text	1
23 Heat Shrink Tube (Wi-Fi-3)	PE	Yellow Tube /Black Text	1
24 Heat Shrink Tube(GNSS)	PE	Blue Tube/White Text	1
25 CE,WEEE and UKCA mark logo Label	PEPA	White	1

Cable length from base	
Cable P/N	L
4G-5G-1	300
4G-5G-2	275
4G-5G-3	275
4G-5G-4	250
4G-5G-5	200
4G-5G-6	200
4G-5G-7	225
4G-5G-8	225
WiFi-1	250
WiFi-2	225
WiFi-3	225
GNSS	300

4. Packaging

1pc Antenna per Large PE Bag
 Bag Dimensions: 470x470mm
 Weight: 0.58Kg



8pcs per Carton
 Carton Dimensions: 370x370x300mm
 Weight: 6.1Kg



5. Installation Guide

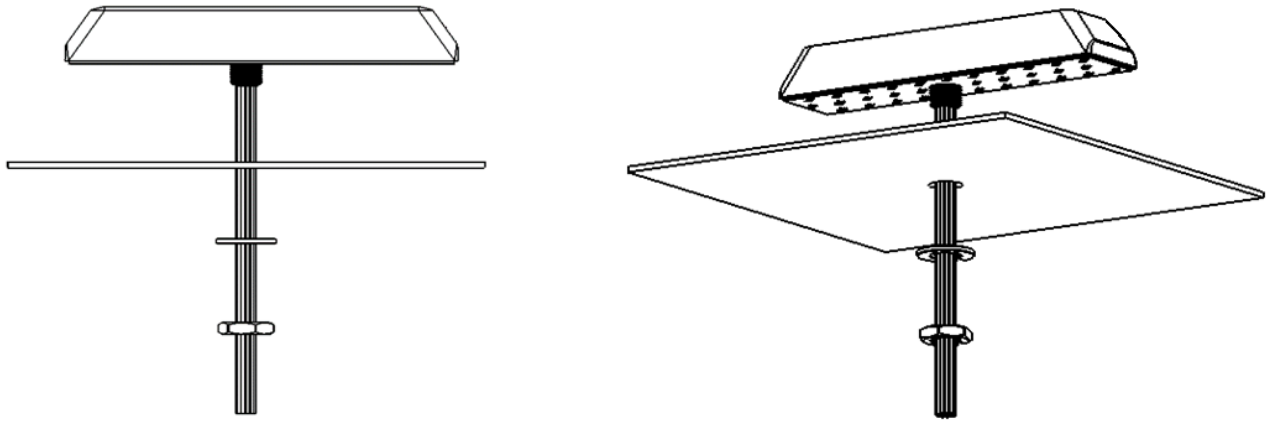

Correct installation of the Raptor Max is required to ensure that the waterproof integrity of the vehicle or enclosure is not compromised.

Step 1: Drill the recommended 30mm diameter hole as indicated below.

Step 2: Ensure that the surface you are mounting to is clean, dry and flat to receive the Raptor Max.

Step 3: Feed the cables through the hole and remove the 3m adhesive backing from the base.

Step 4: Position the Raptor Max into the correct orientation on the mounting surface and firmly press down to activate the 3M adhesive.

Step 5: To permanently mount the antenna, slide the washer and nut over the cable assembly and hand tighten to ensure a secure fit.

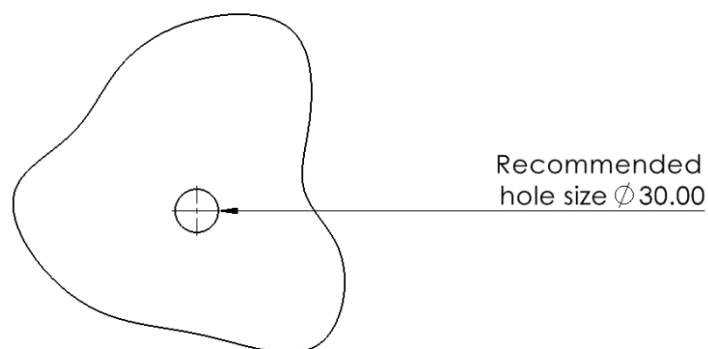

6. Characteristics

6.1 Test Setup

AUT



Vector Network Analyzer

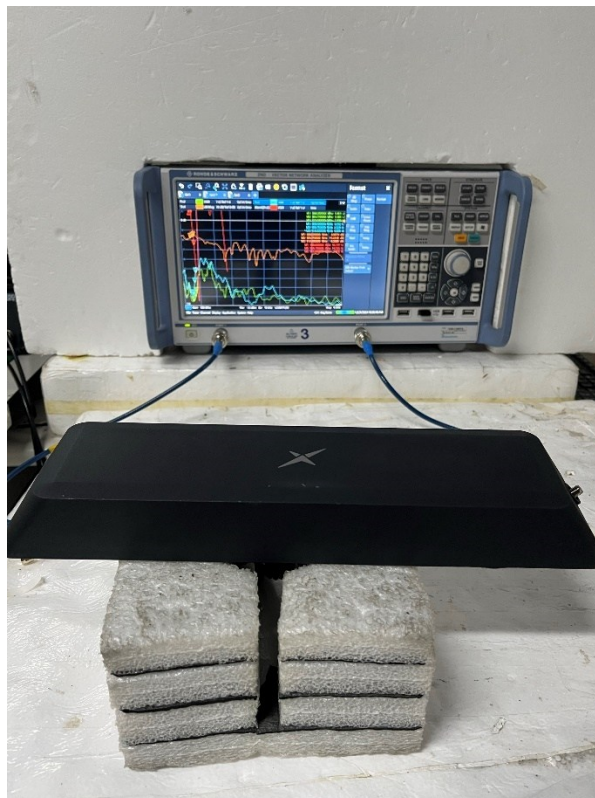

VNA Test Set-up

6.2 GNSS - Return Loss

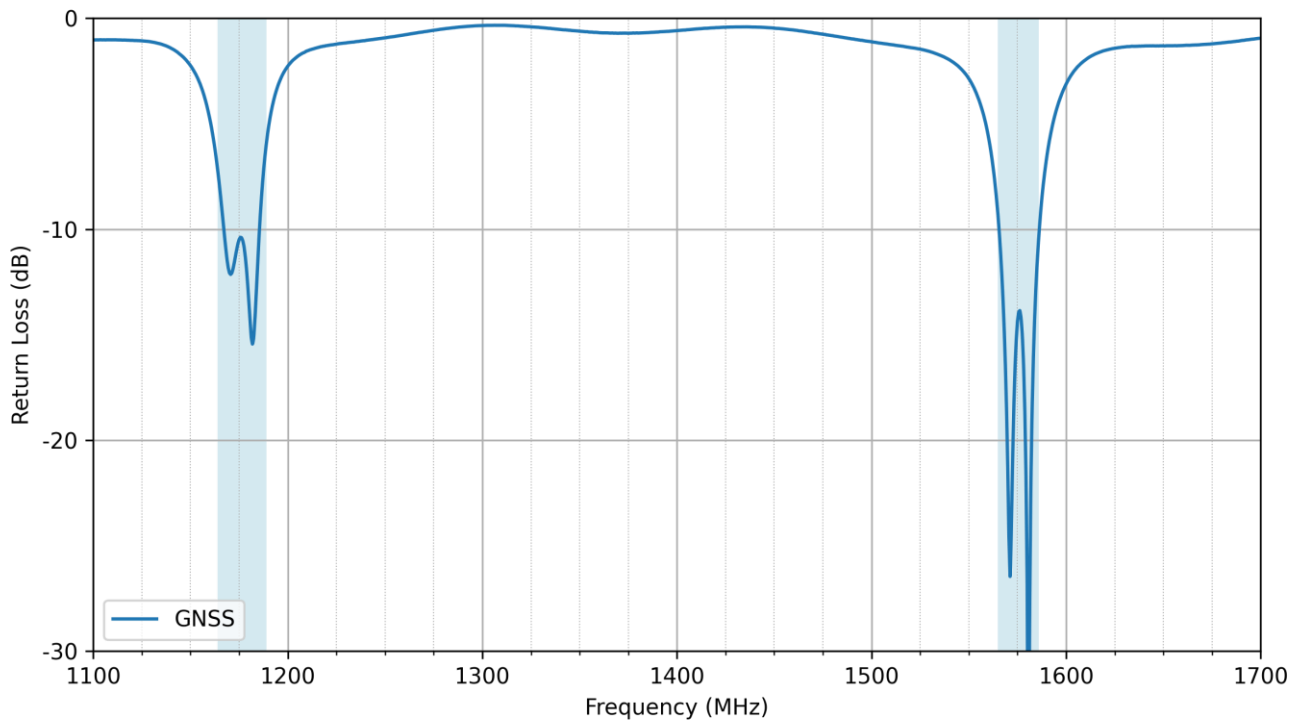

6.3 GNSS - VSWR

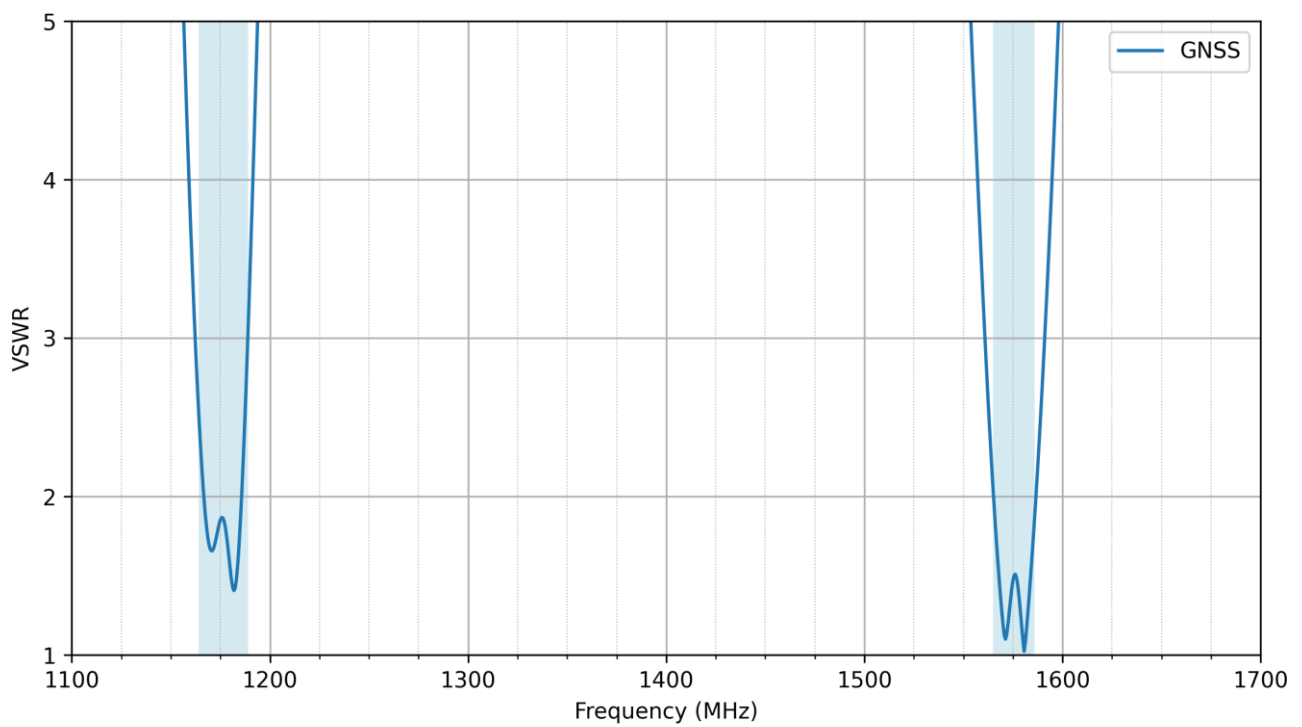

6.4 GNSS - Efficiency

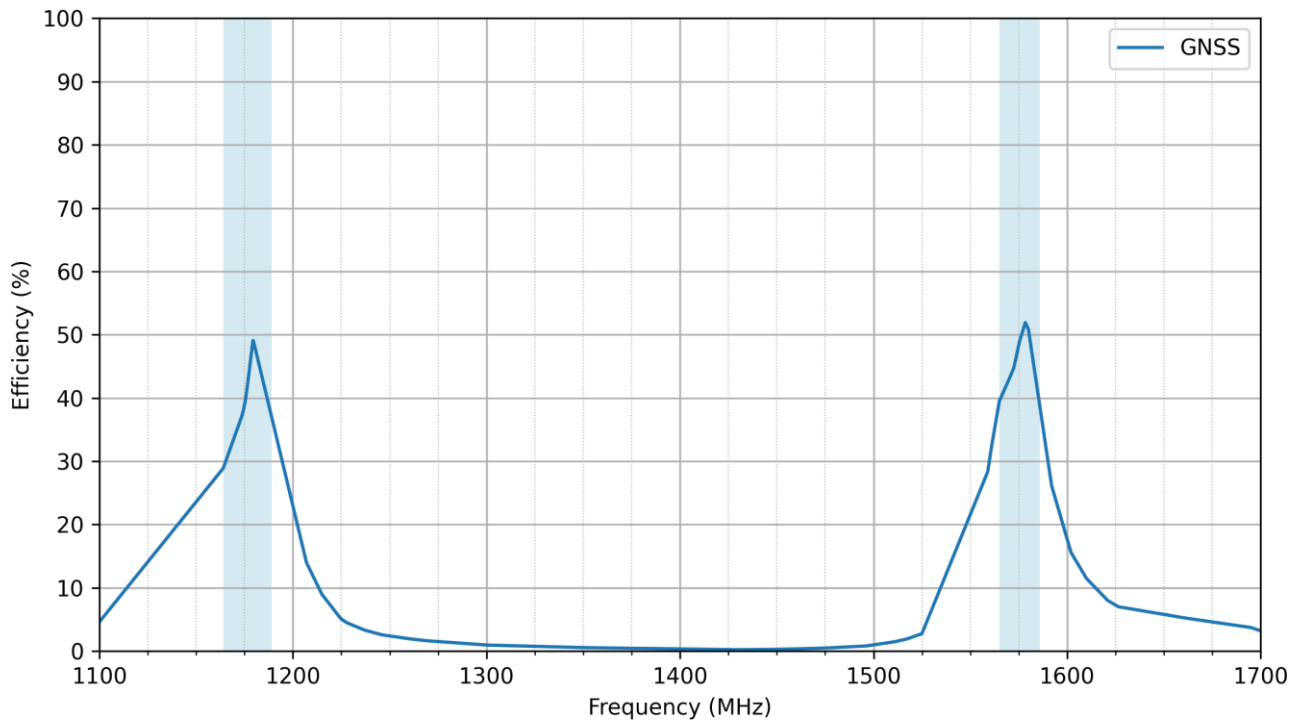

6.5 GNSS - Average Gain

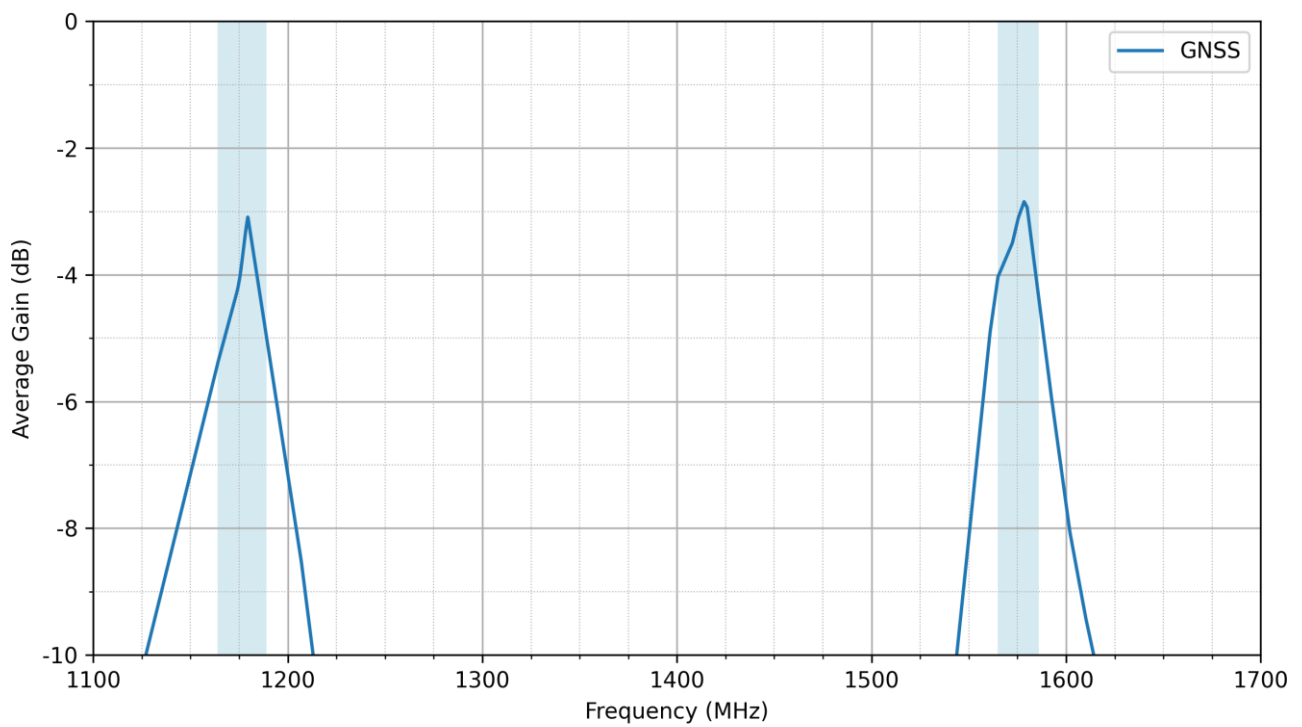

6.6 GNSS - Peak Gain

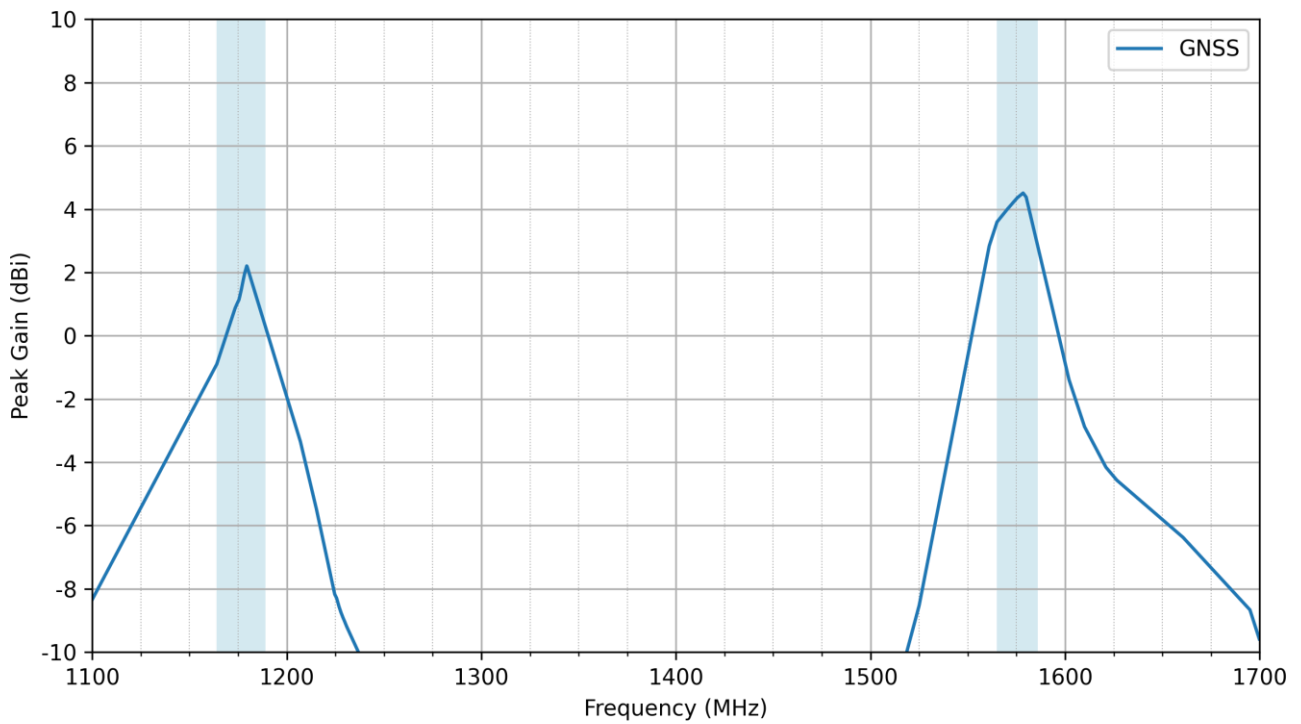

6.7 4G-5G -Return Loss

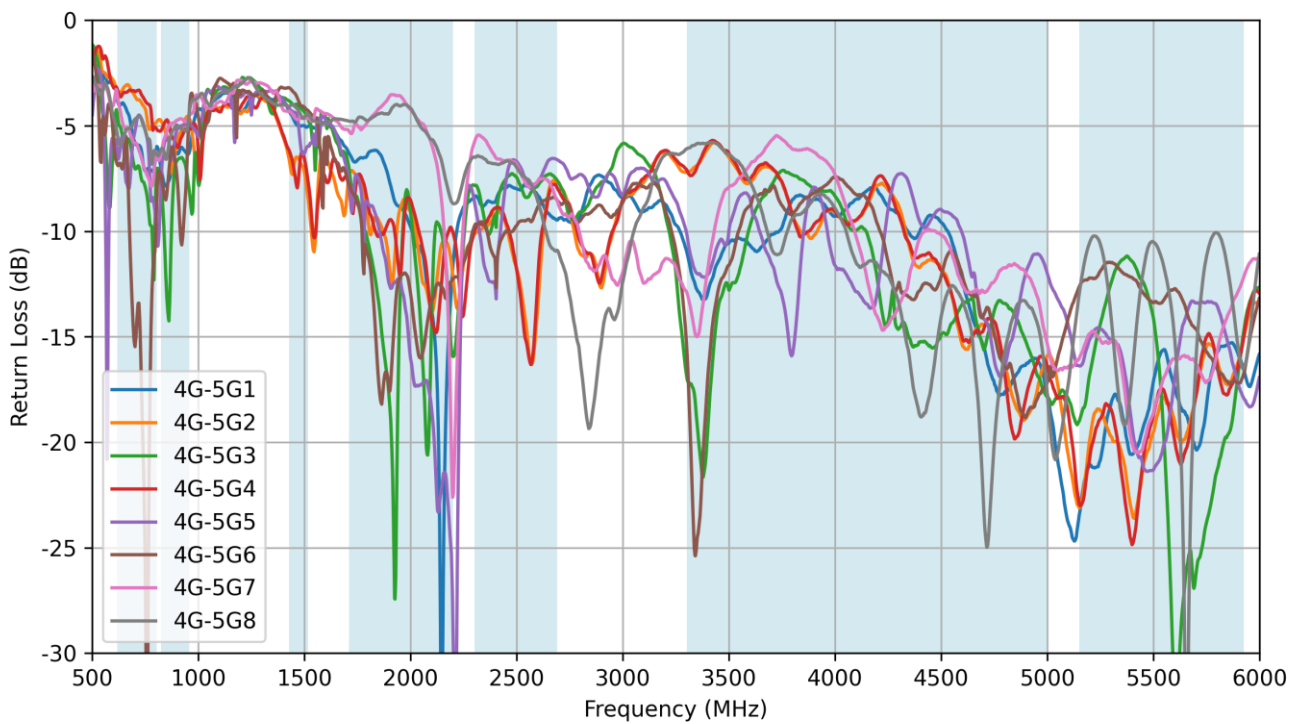

6.8 4G-5G -VSWR

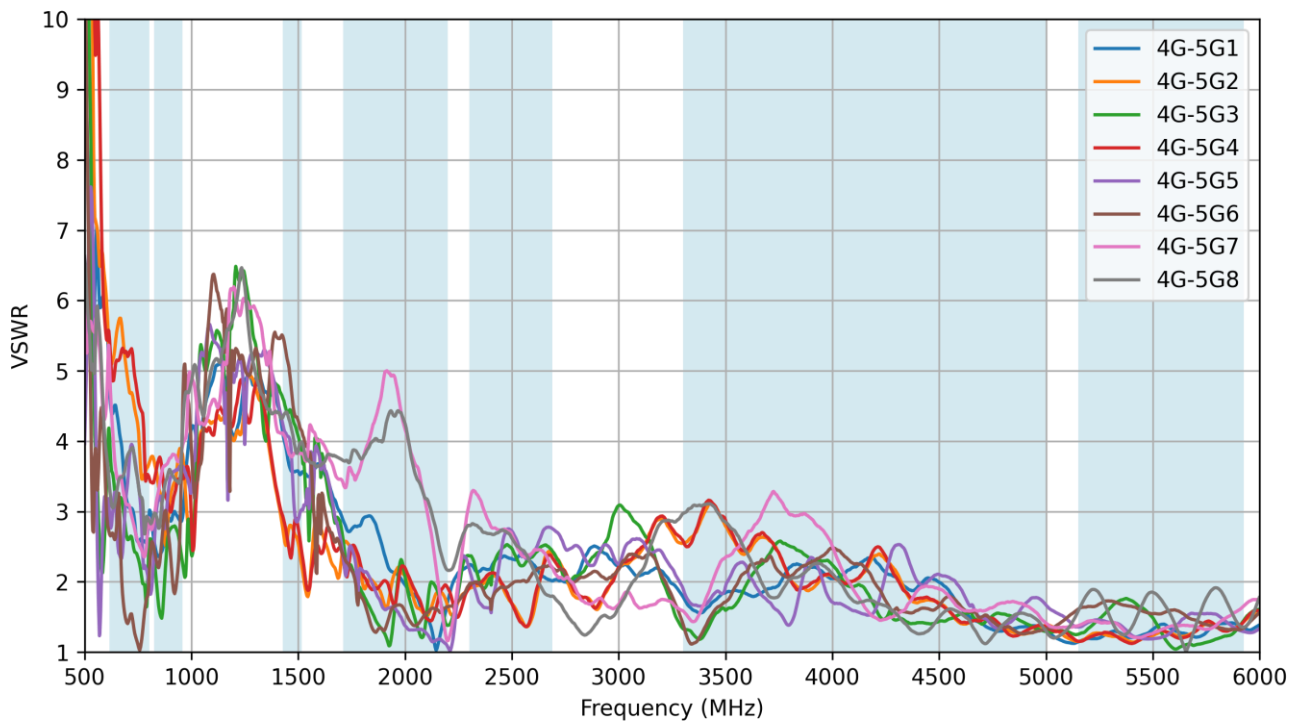

6.9 Isolation

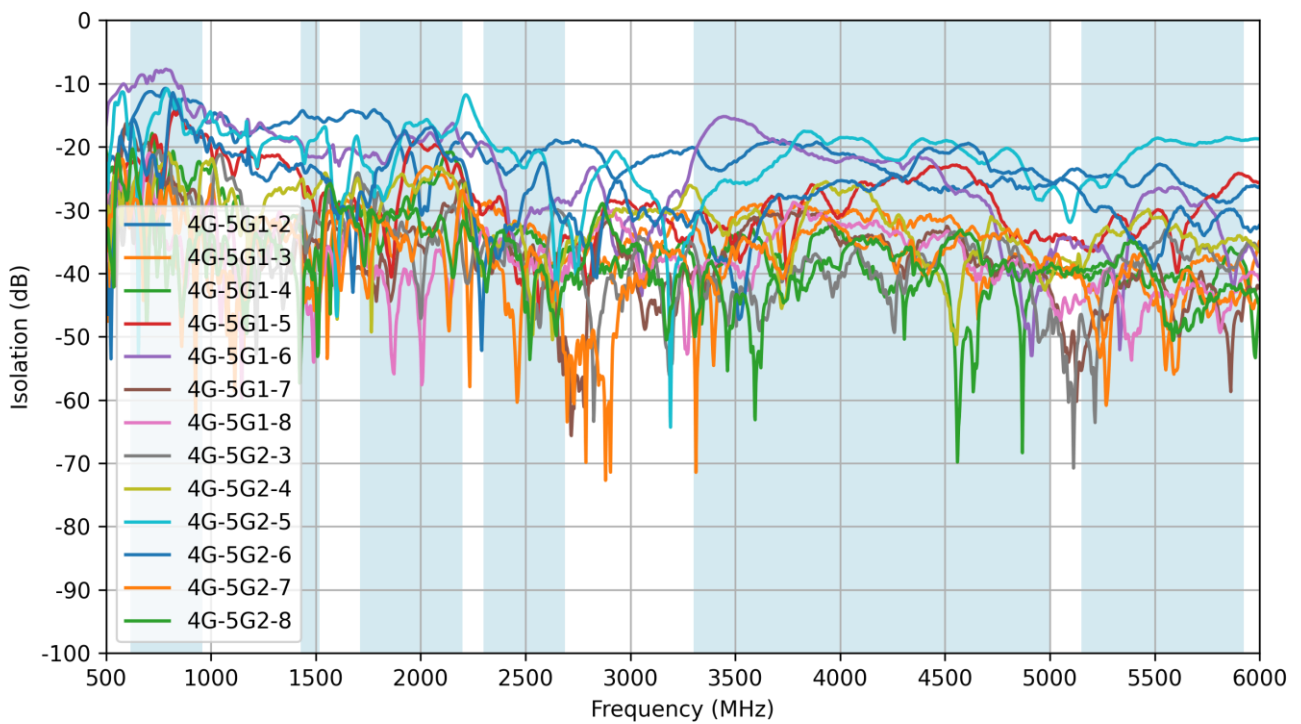

6.10 Isolation

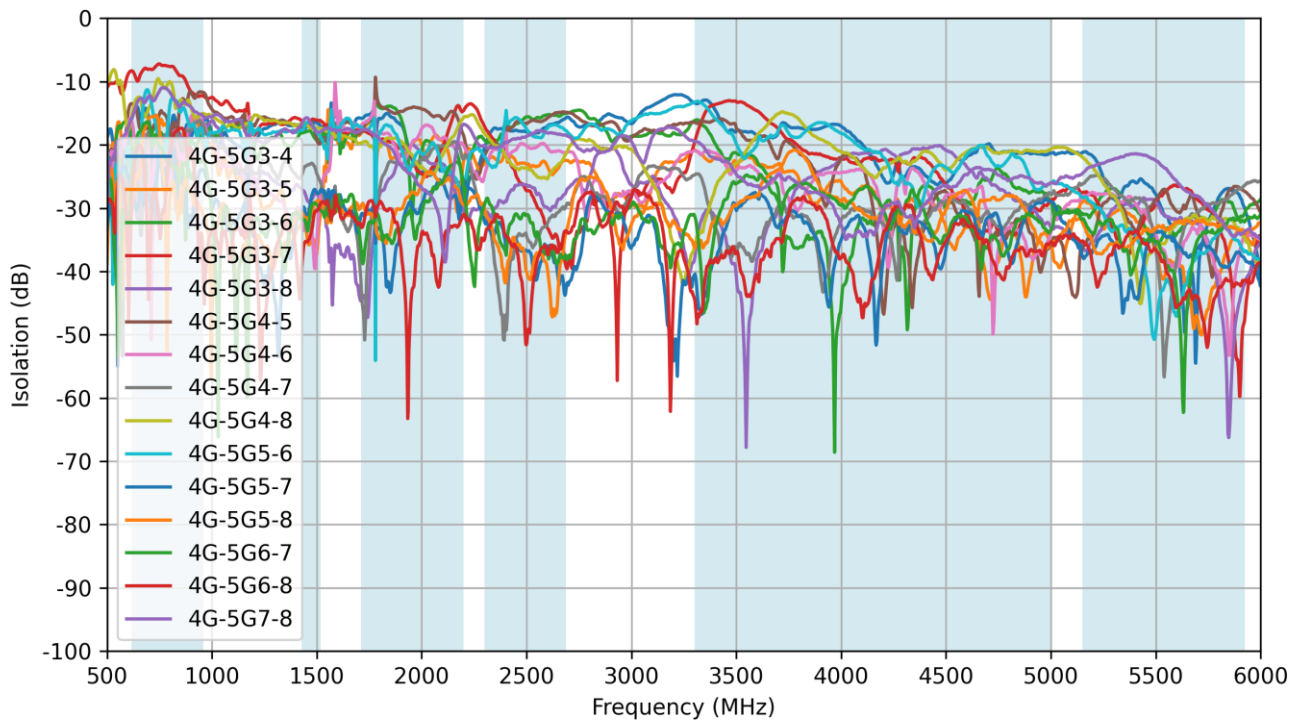

6.11 4G-5G -Efficiency

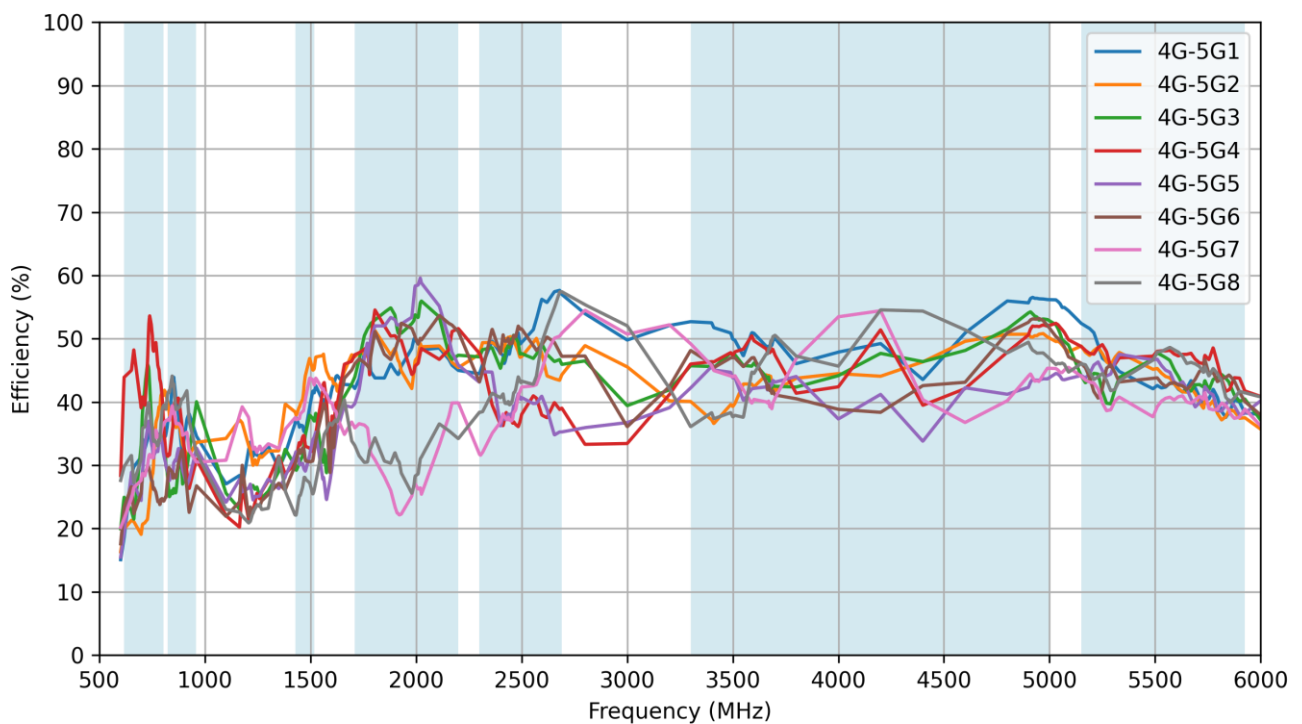

6.12 4G-5G -Average Gain

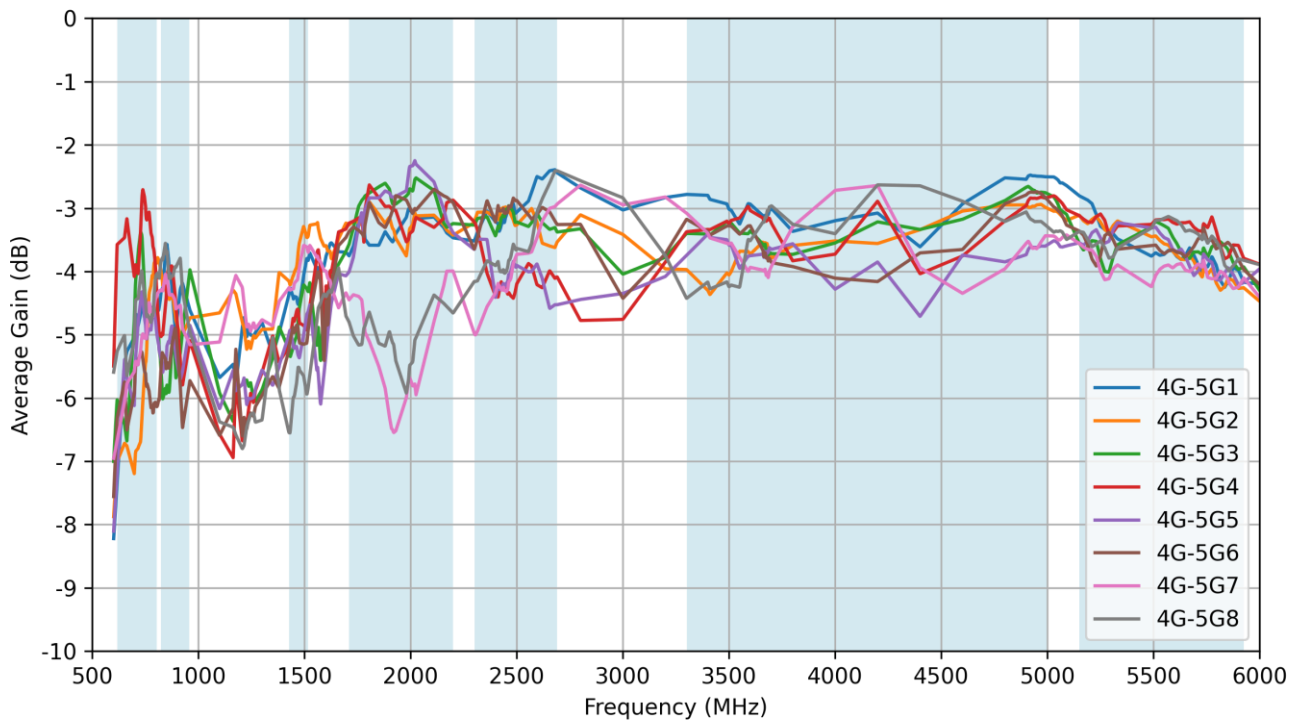

6.13 4G-5G -Peak Gain

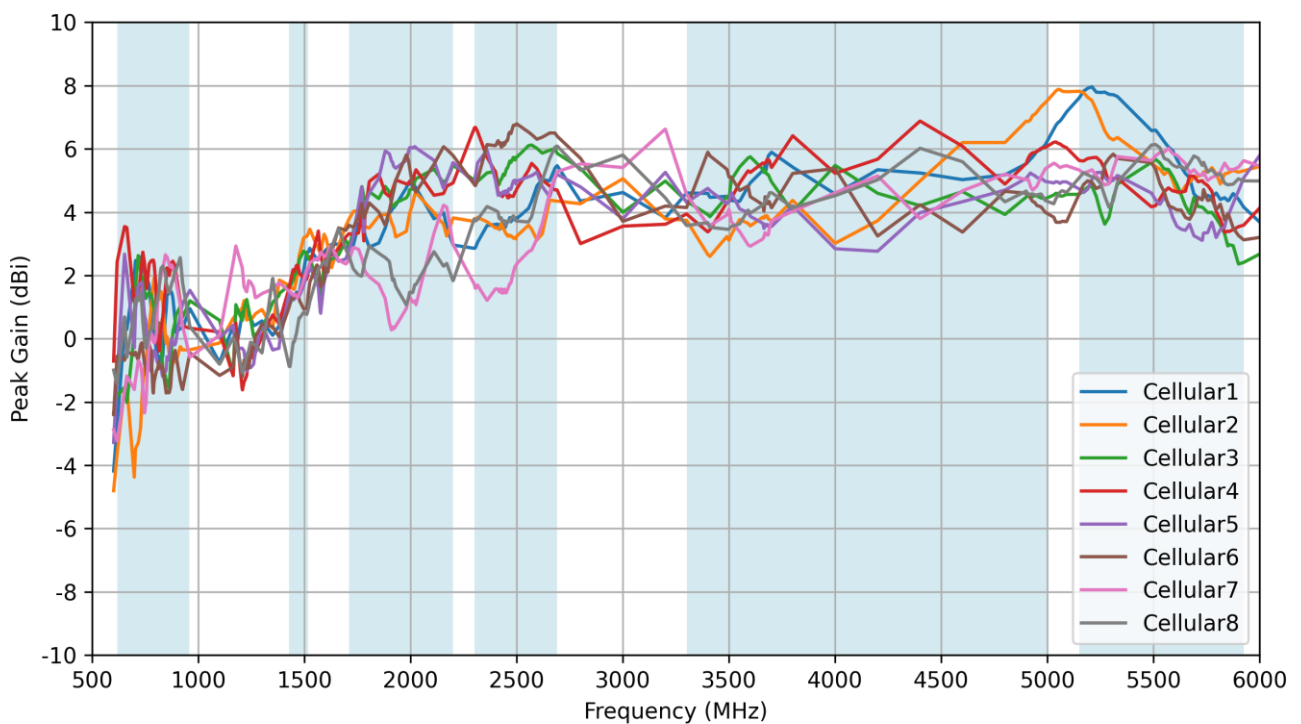

6.14 Wi-Fi - Return Loss

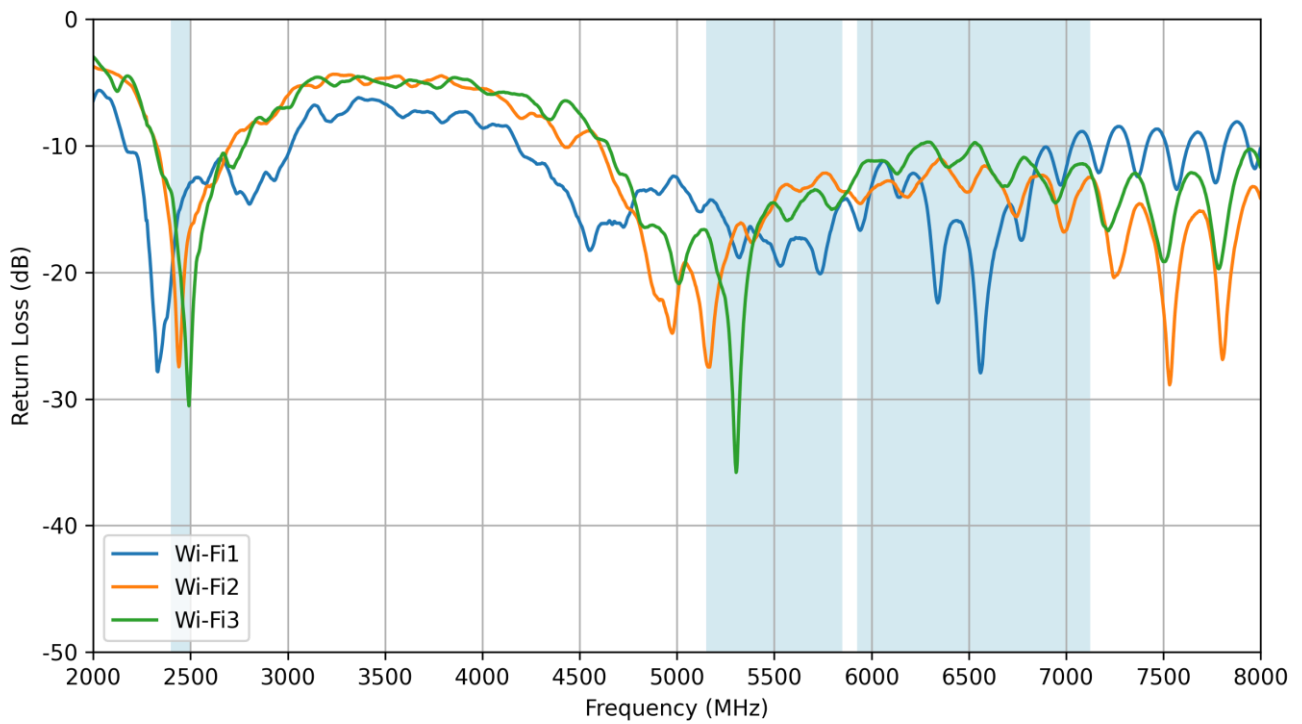

6.15 Wi-Fi - VSWR

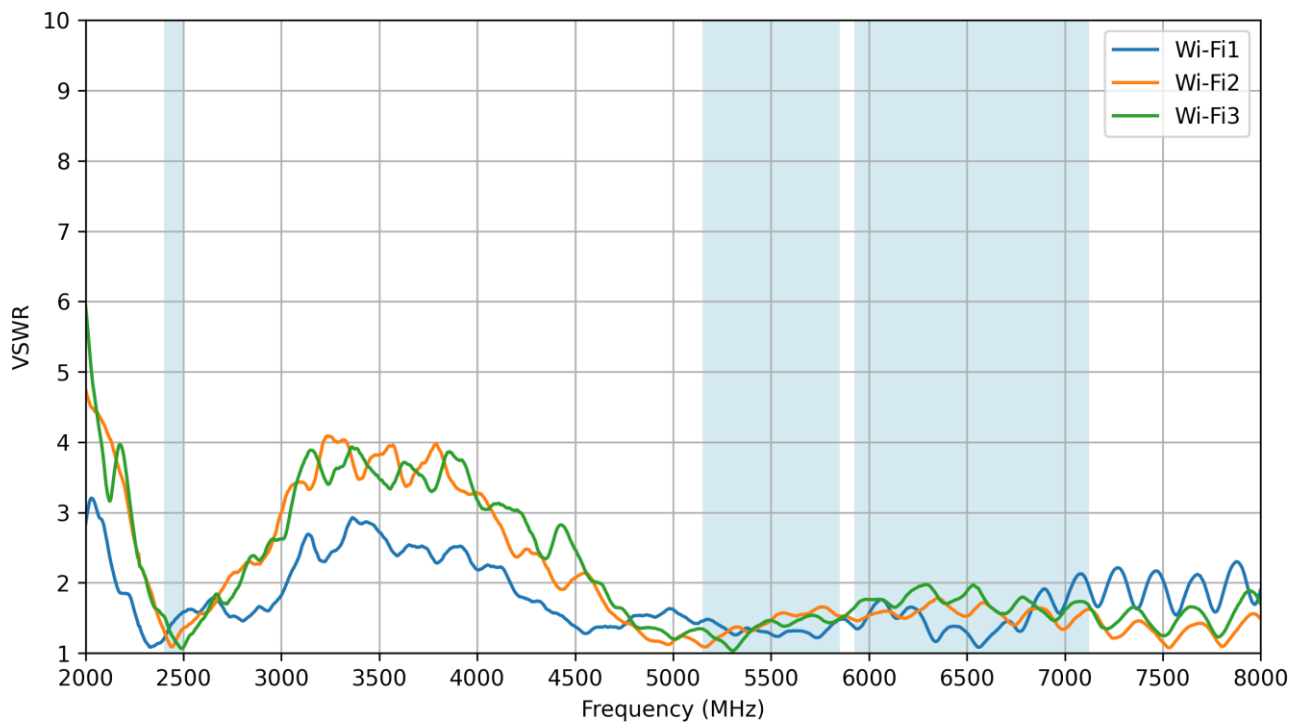

6.16 Wi-Fi - Isolation

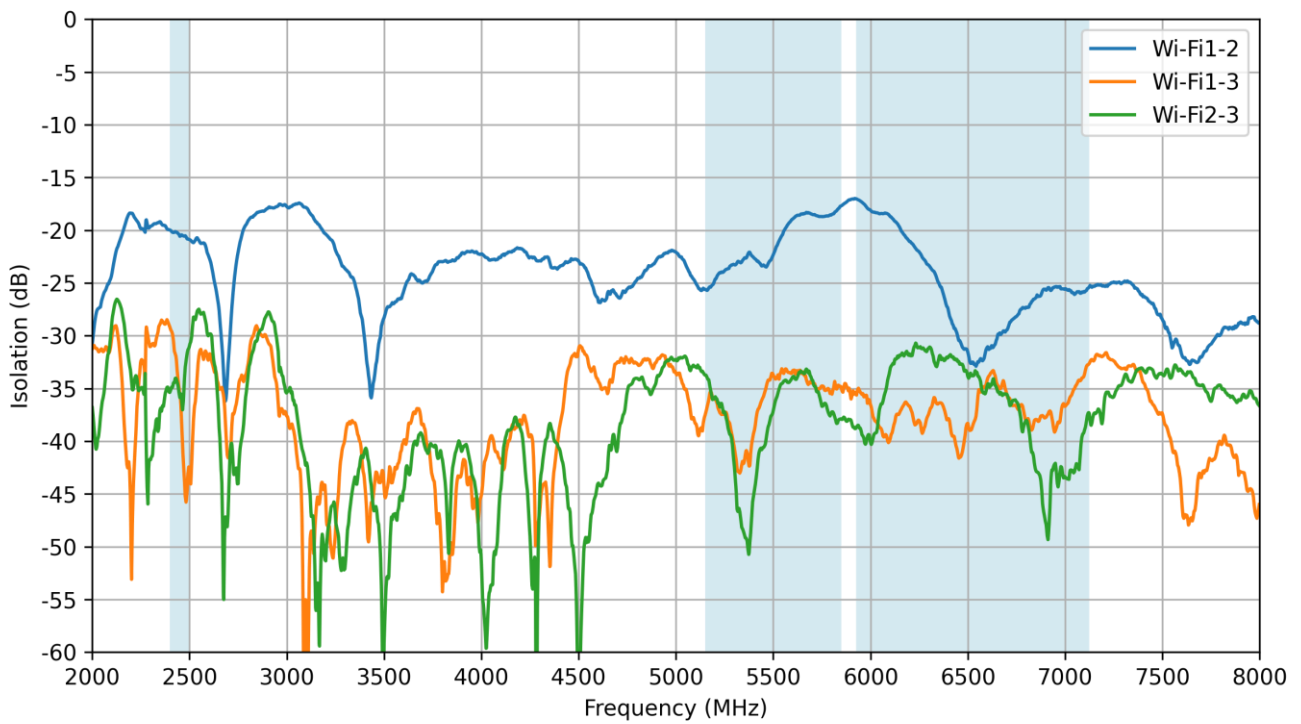

6.17 Wi-Fi - Efficiency

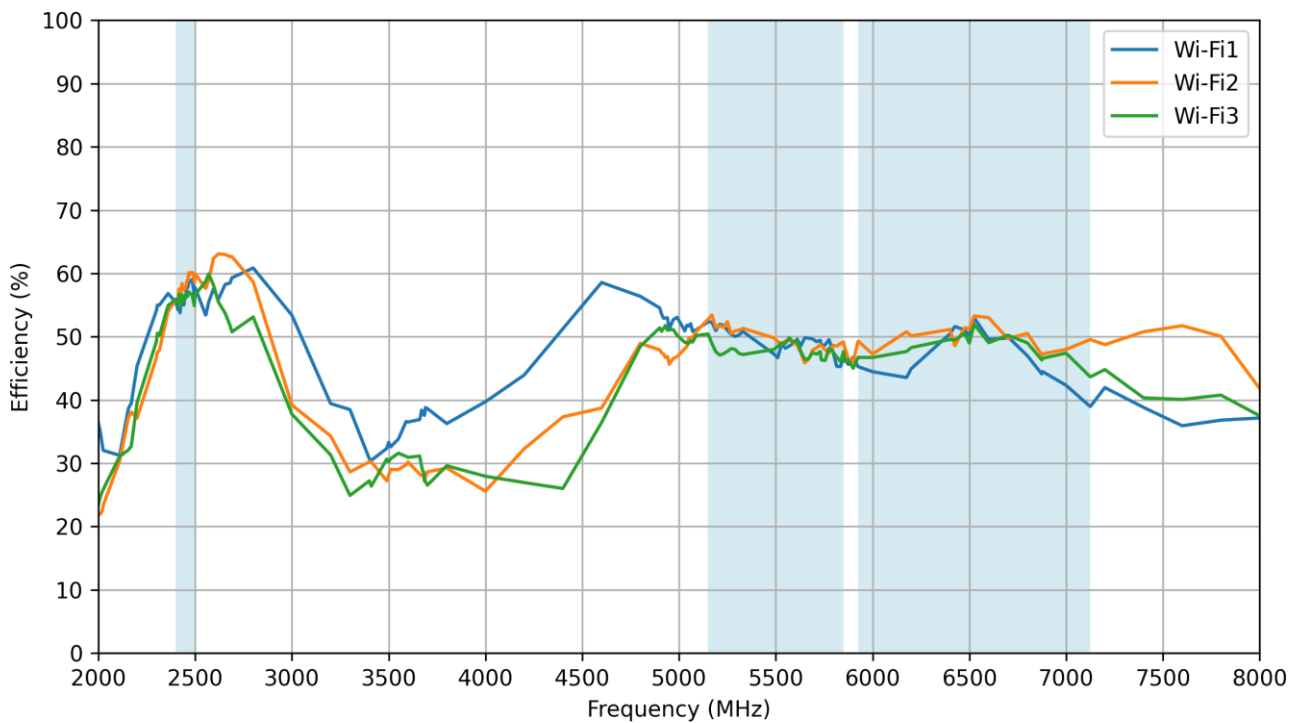

6.18 Wi-Fi - Average Gain

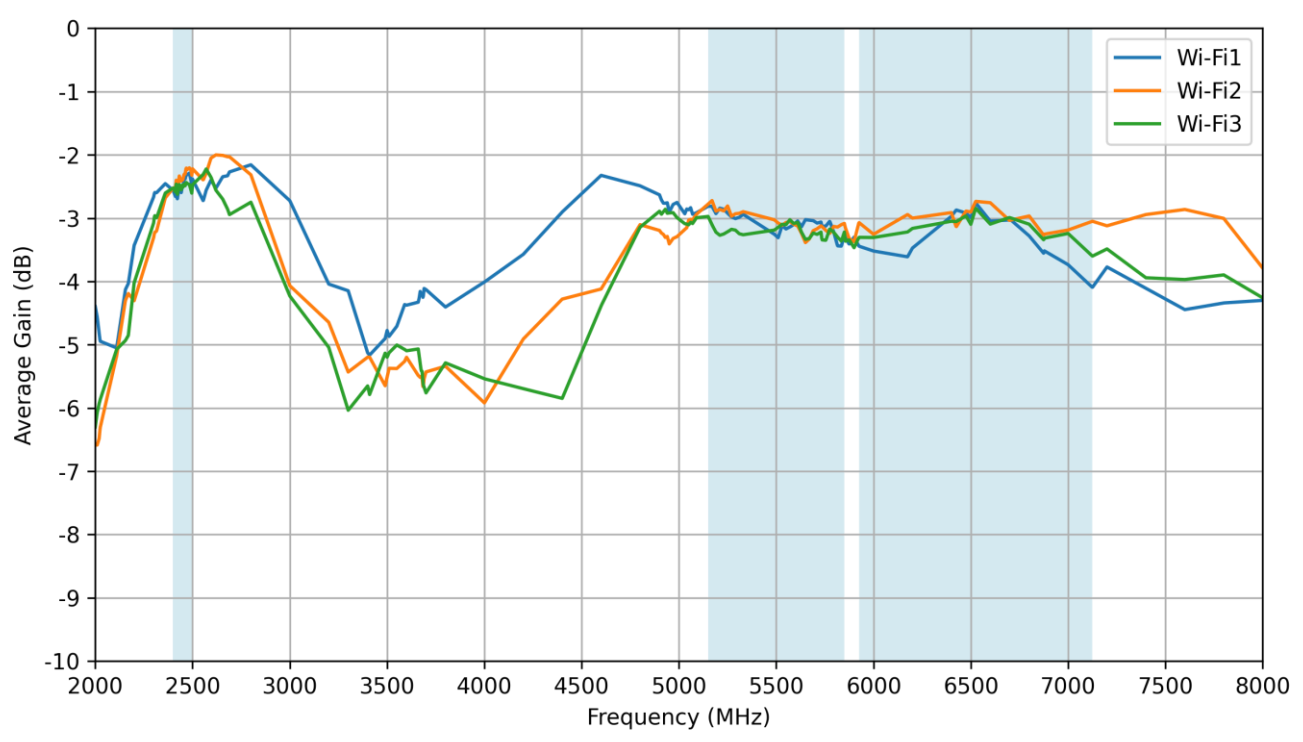

6.19 Wi-Fi - Peak Gain

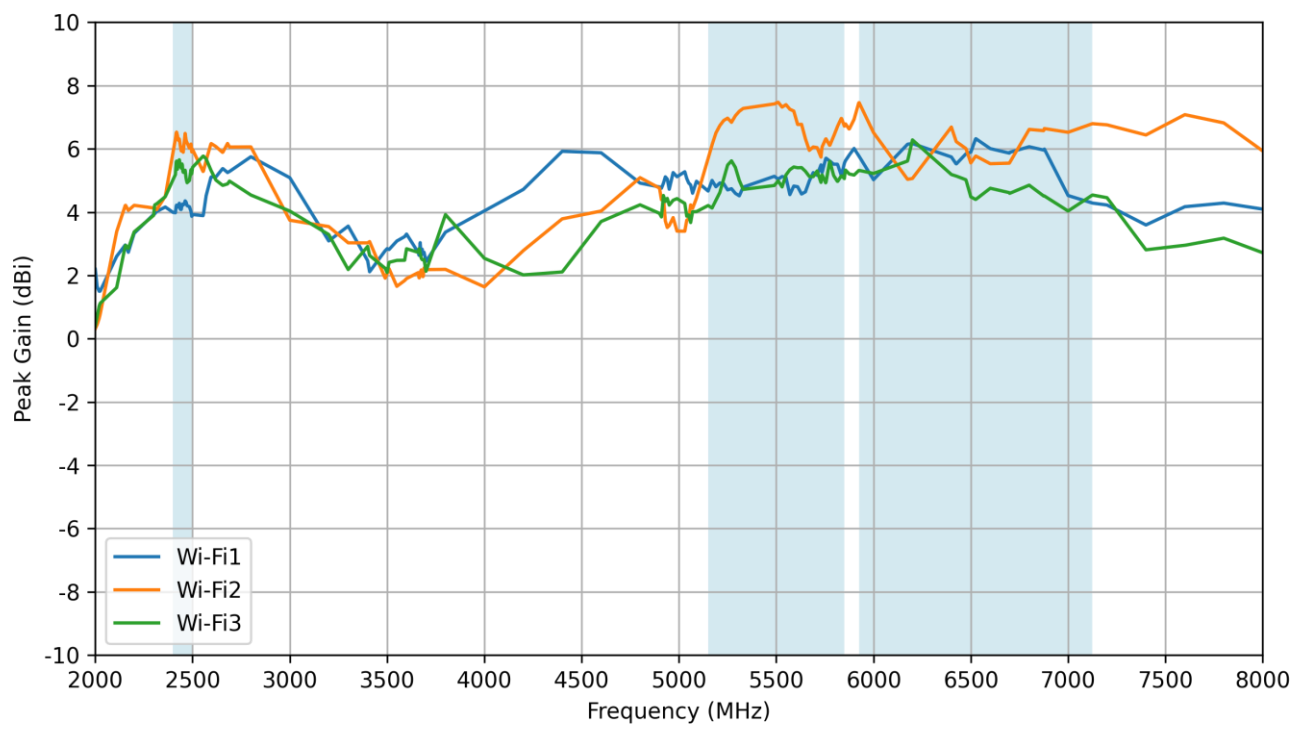

7. LNA Characteristics

7.1 Block Diagram

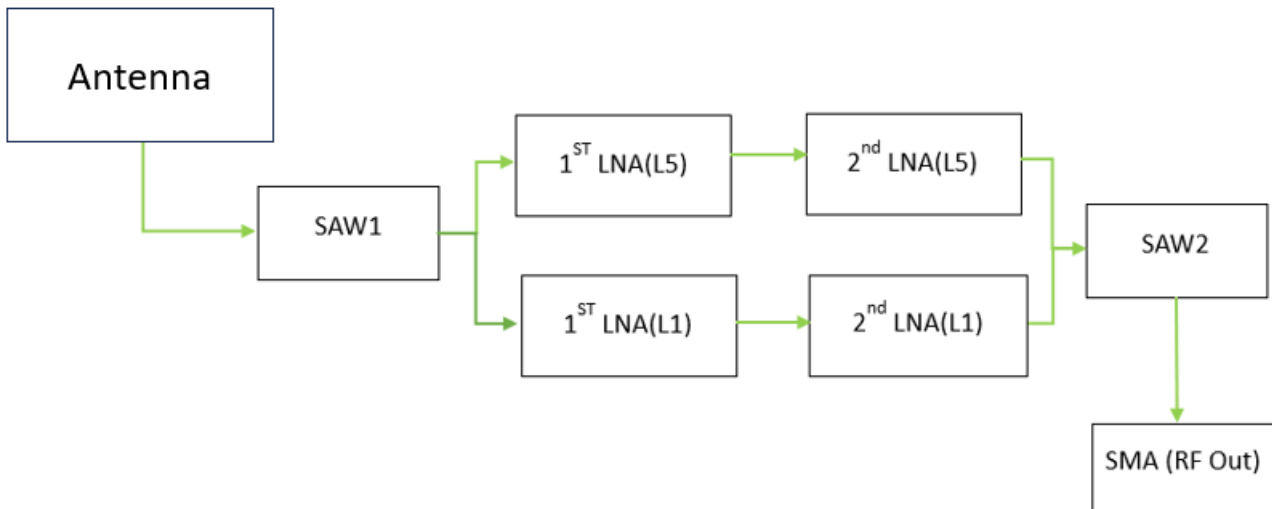

7.2 Noise Figure – Low-Band

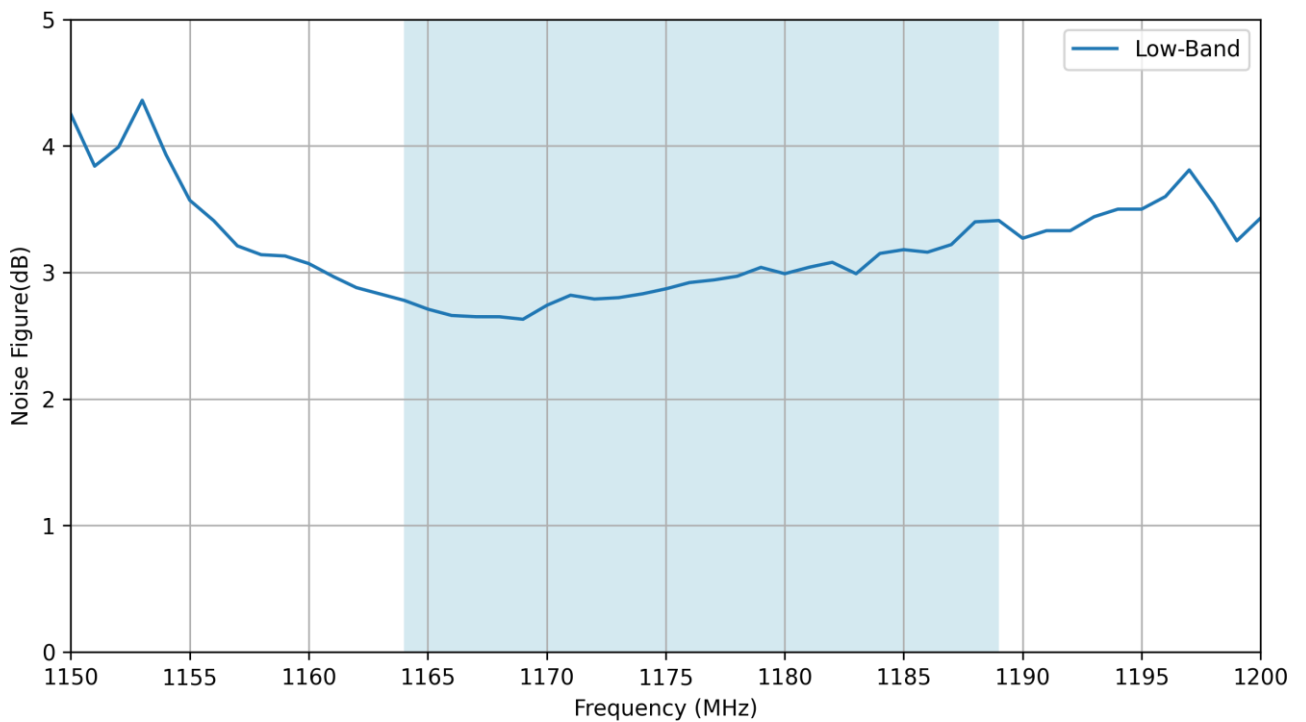

7.3 Noise Figure – High-Band

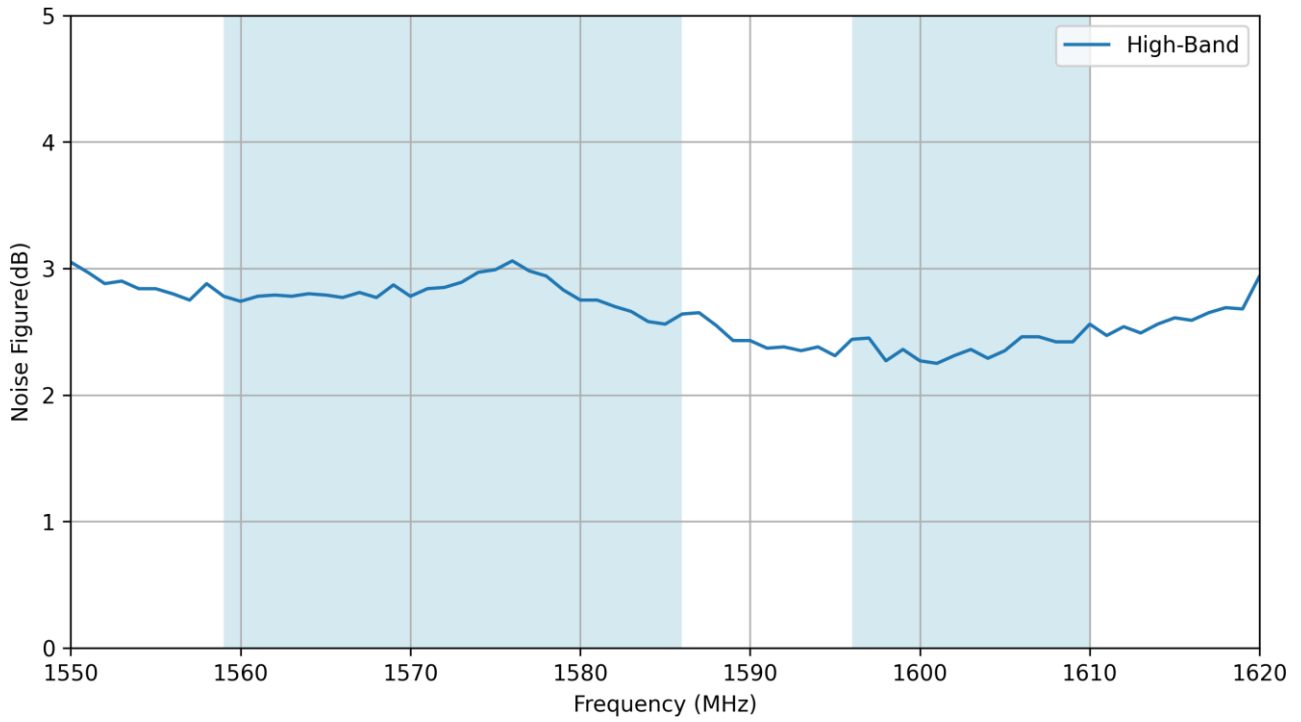

7.4 Gain – Low-Band

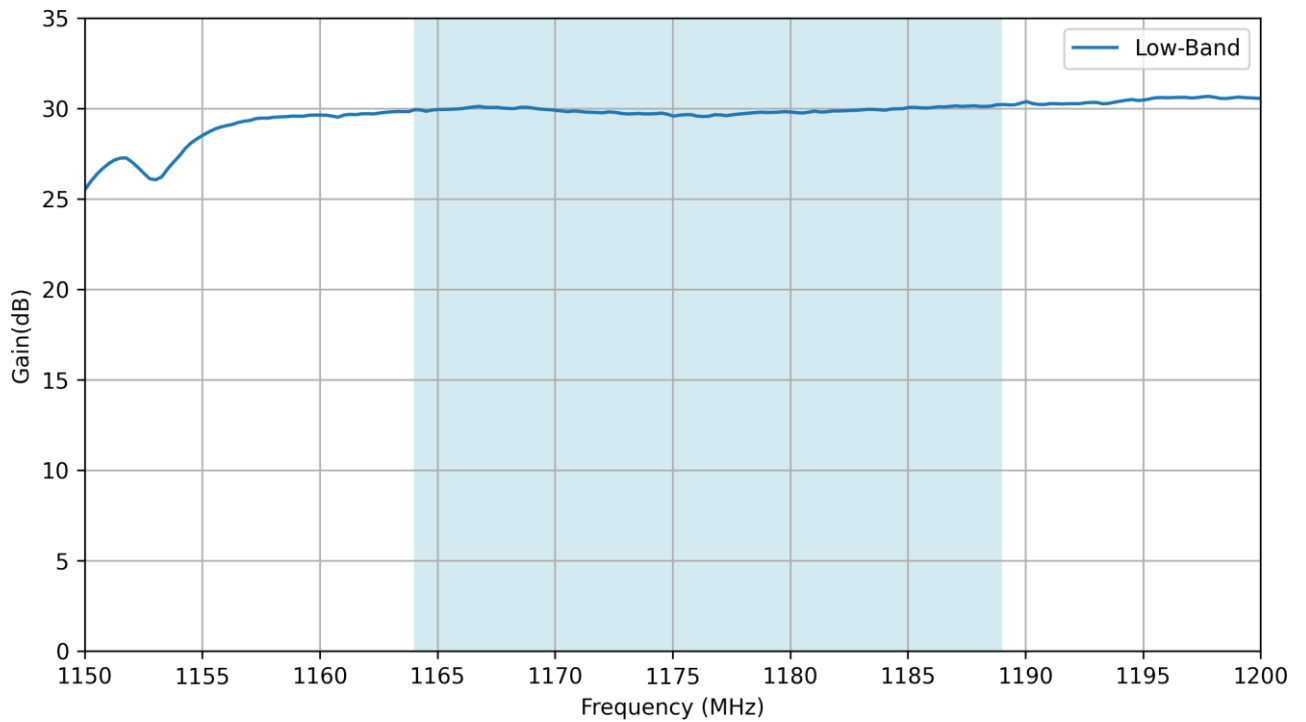

7.5 Gain – High-Band

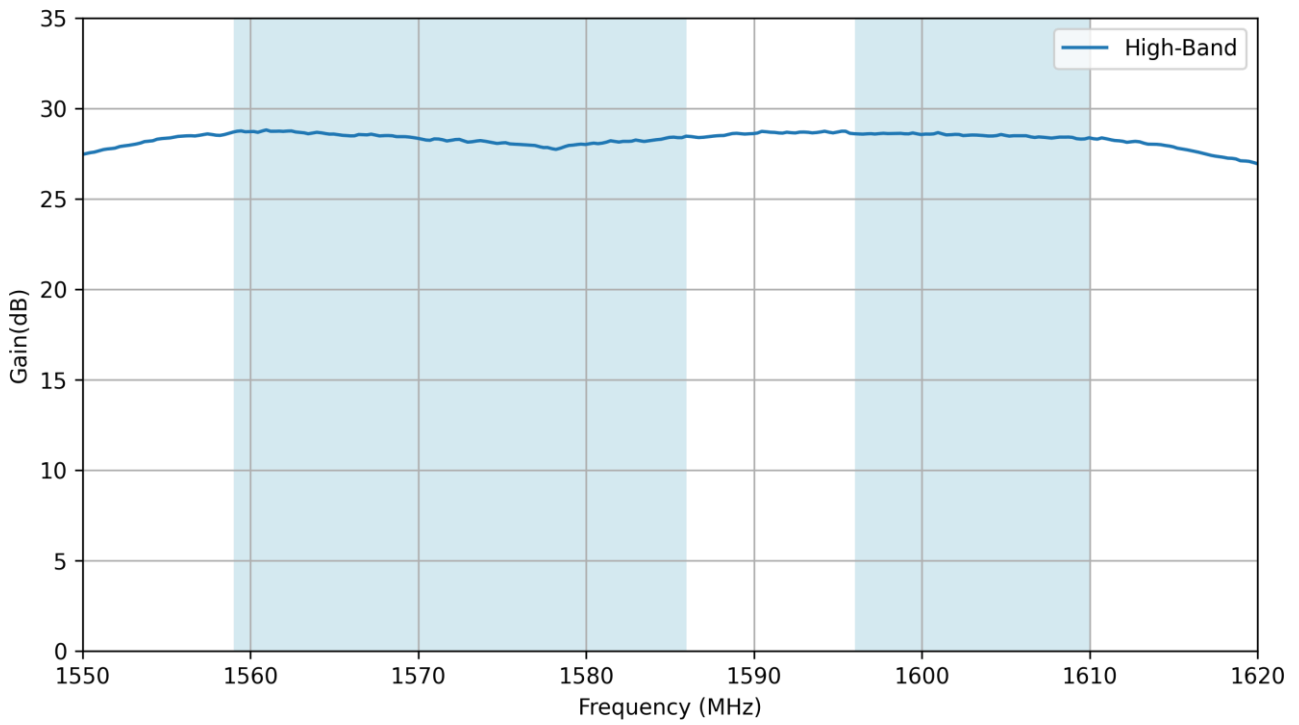

7.6 Gain – Wide-Band

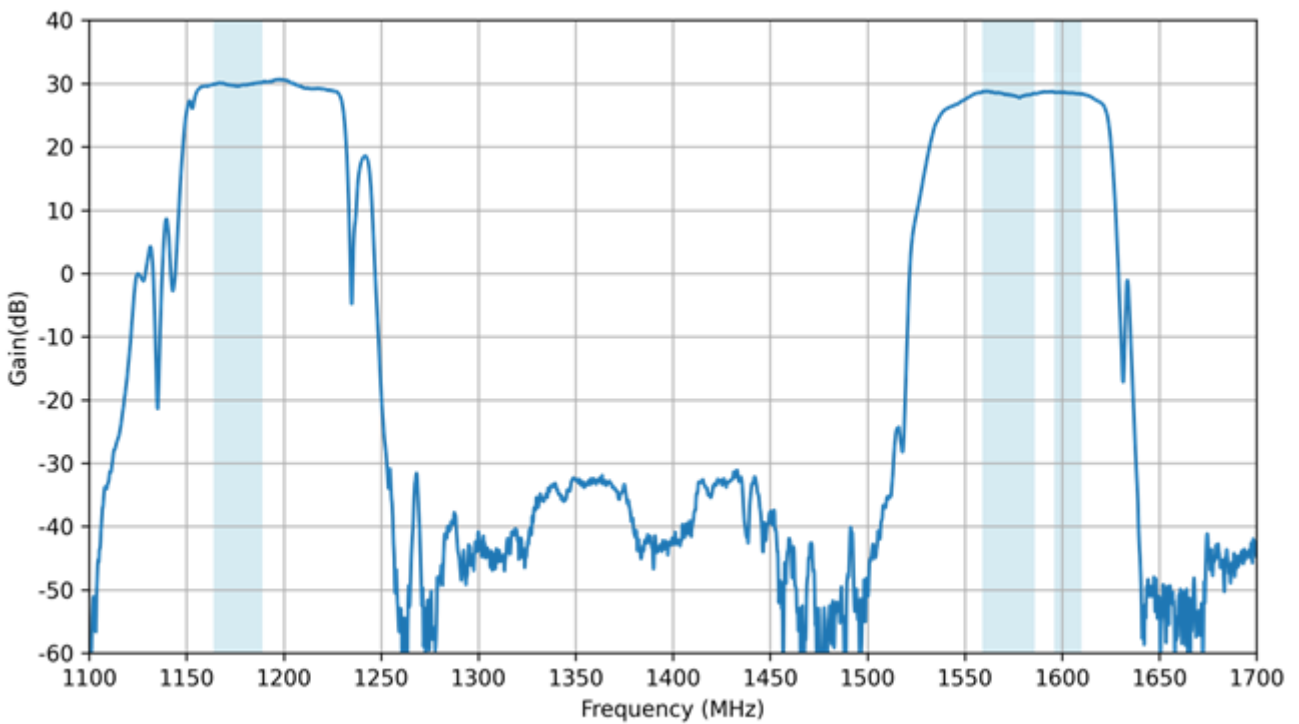

7.7 Out Of Band Rejection

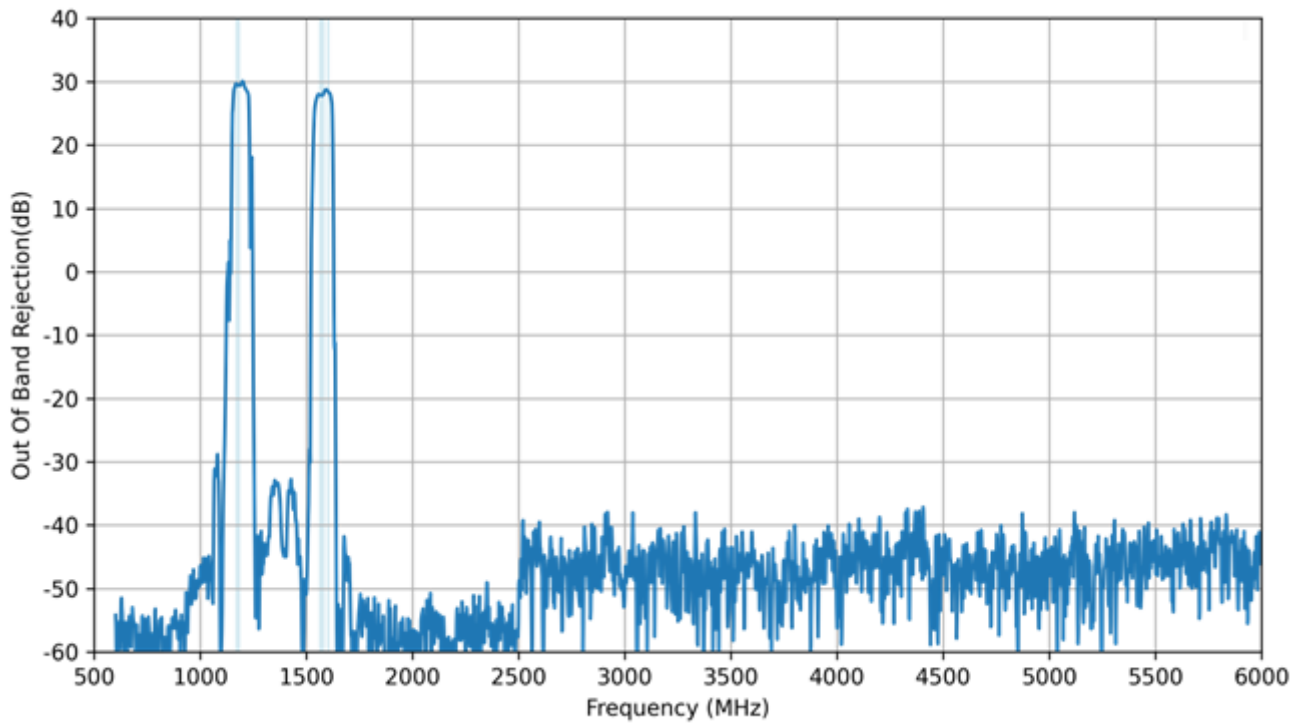

7.8 Group Delay - High-Band

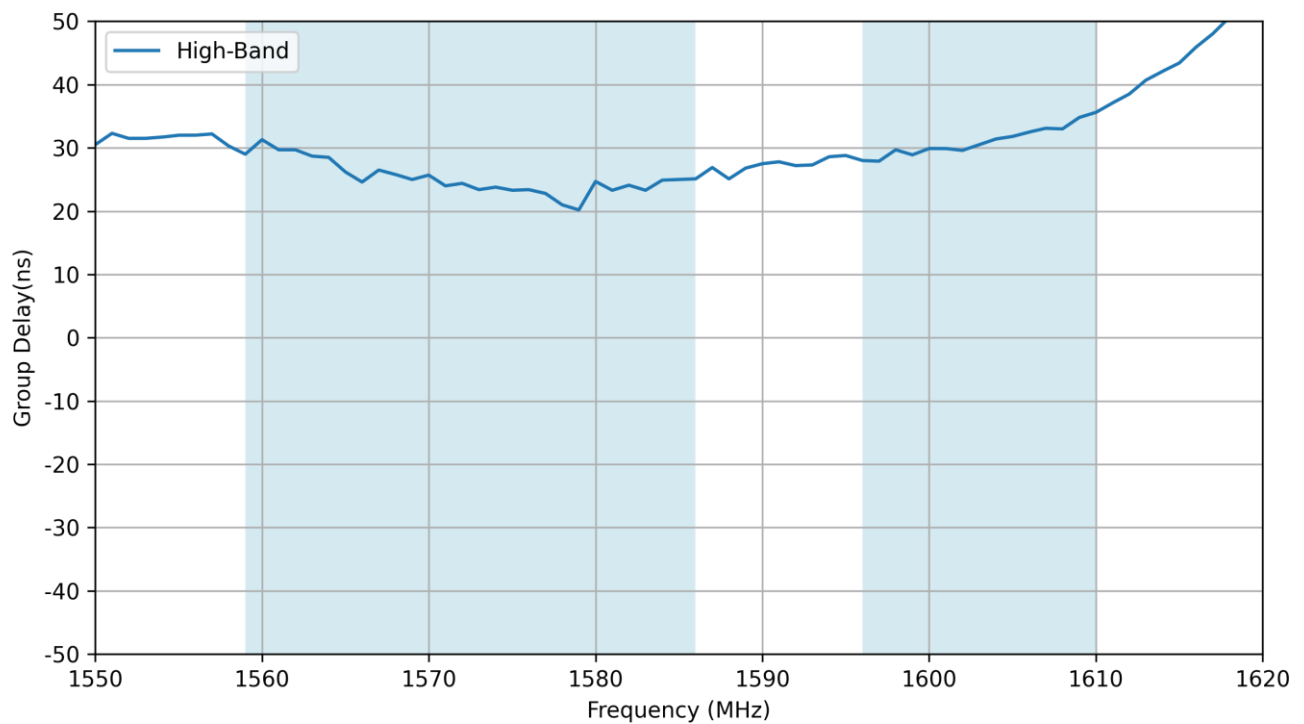

7.9 Group Delay - Low-Band

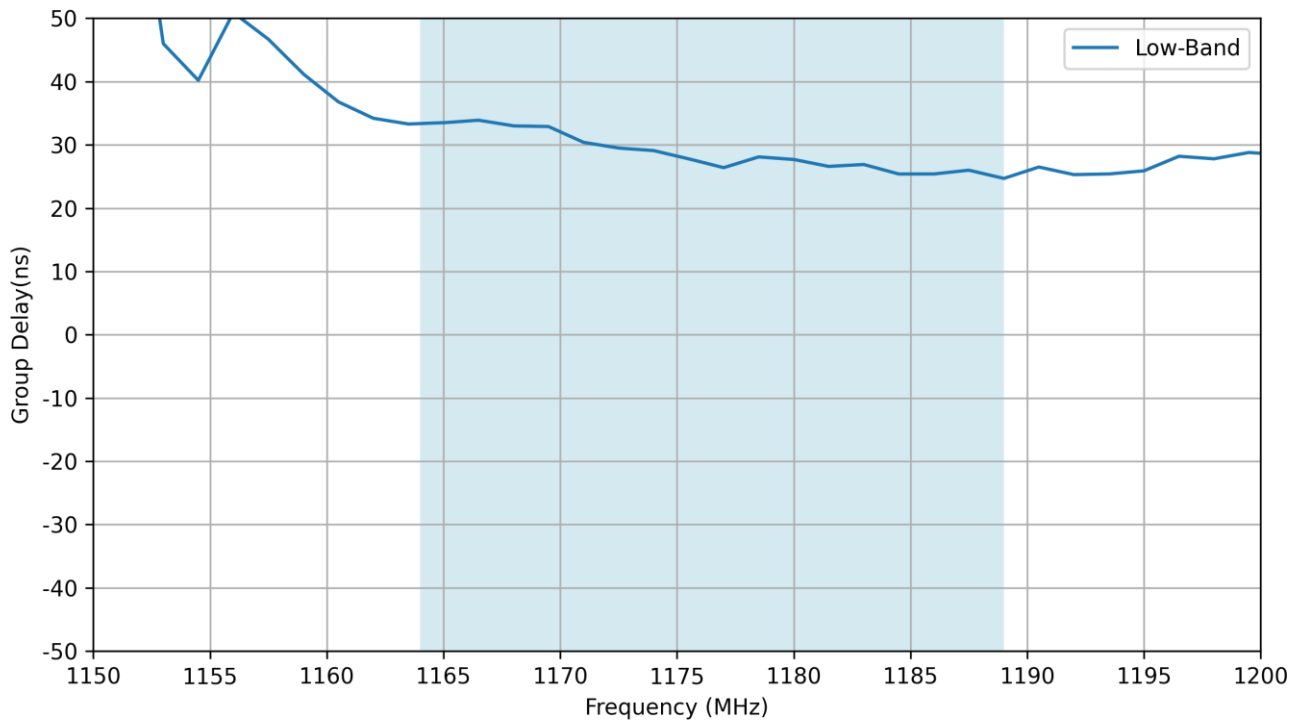

8. Radiation Patterns

8.1 Test Setup

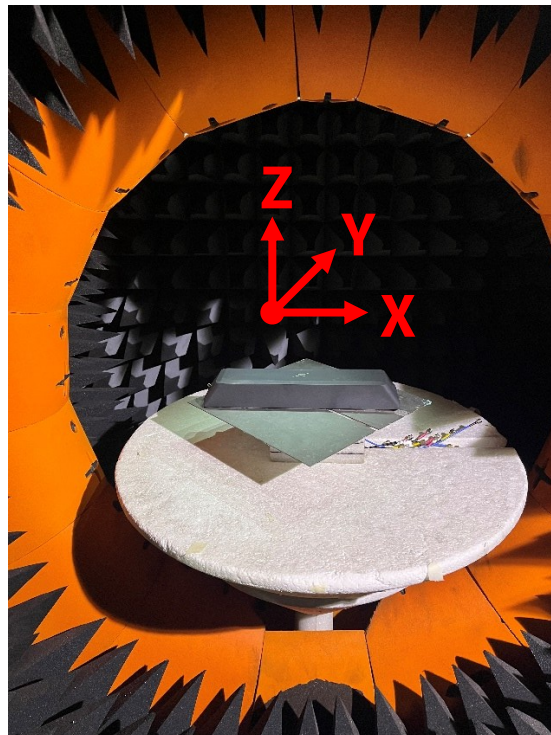
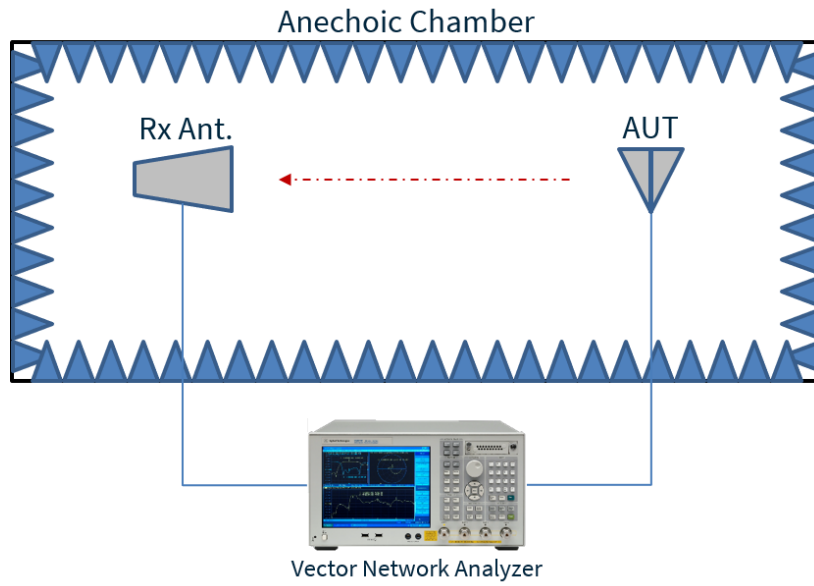

8.2 GNSS Patterns at 1176 MHz

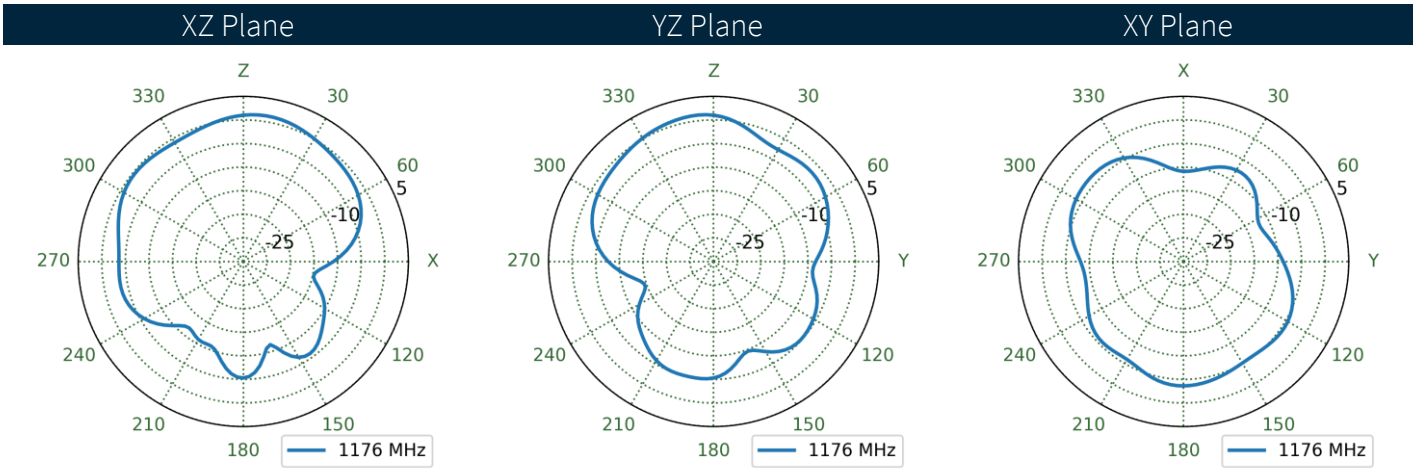
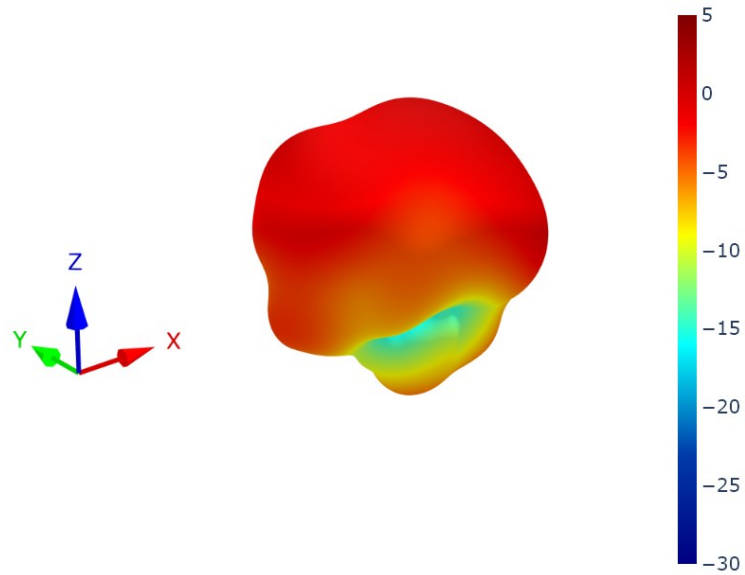

8.3 GNSS Patterns at 1575 MHz

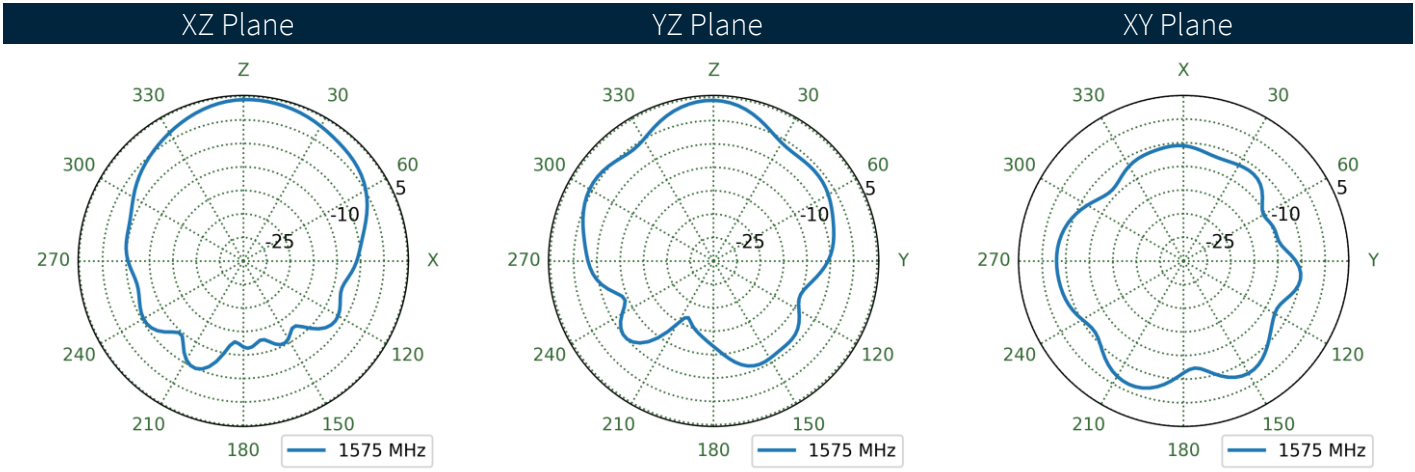
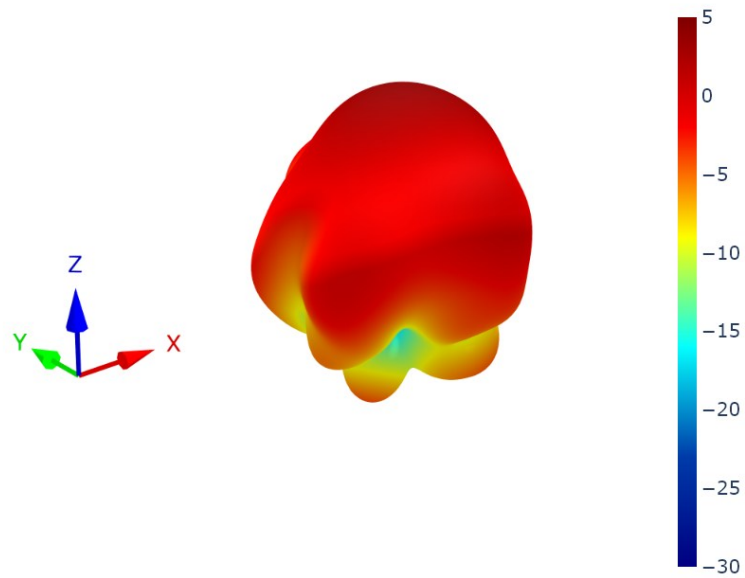

8.4 4G-5G 1 Patterns at 652 MHz

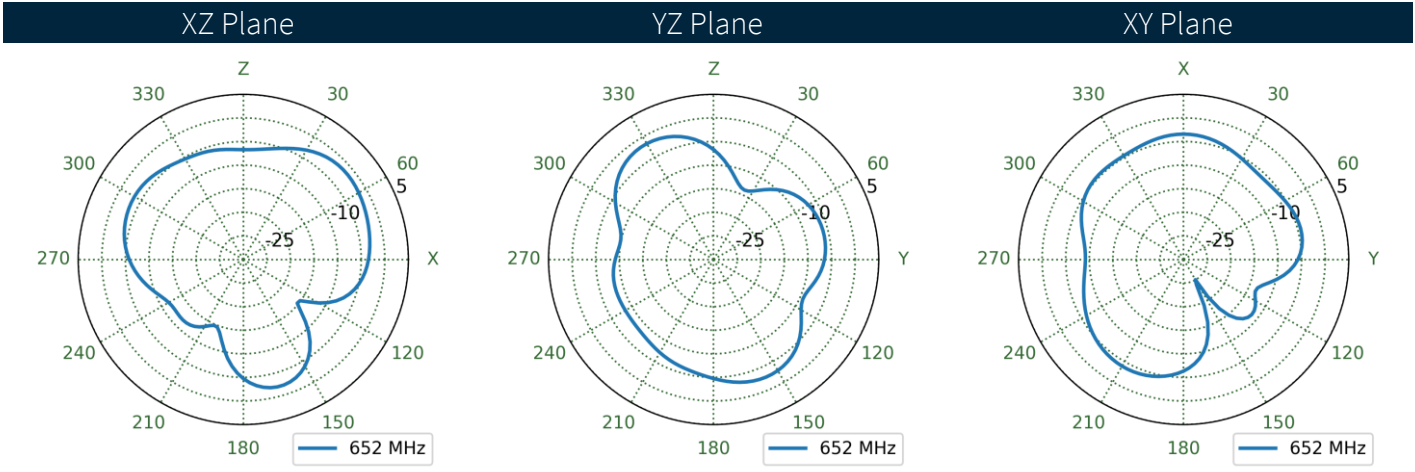
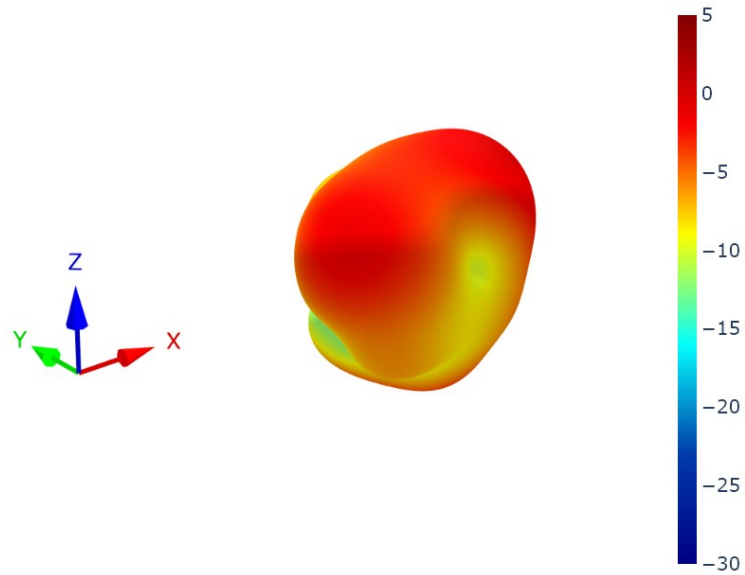

8.5 4G-5G 2 Patterns at 652 MHz

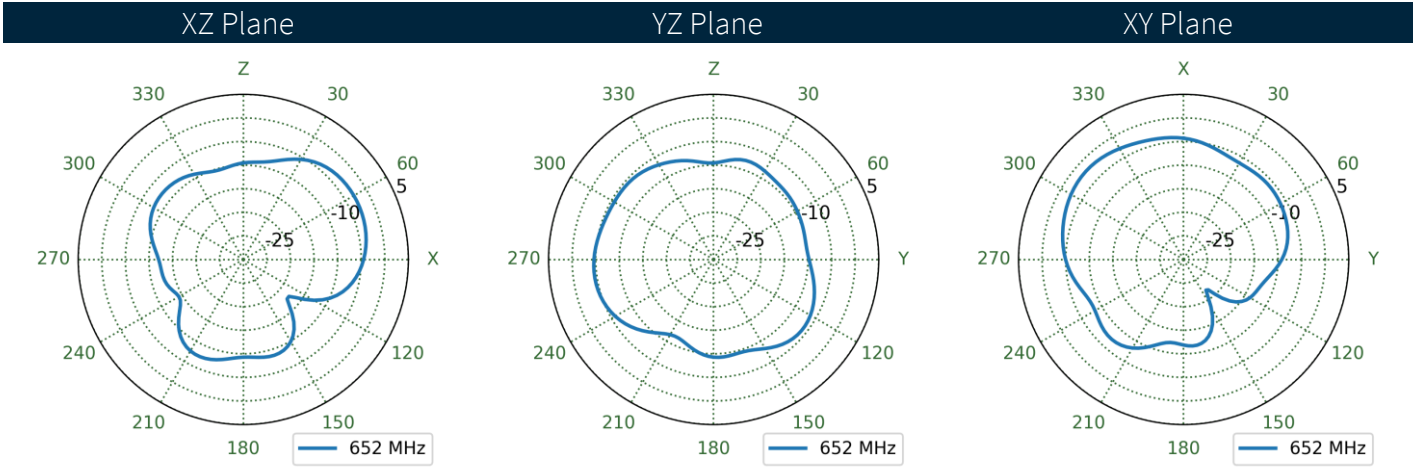
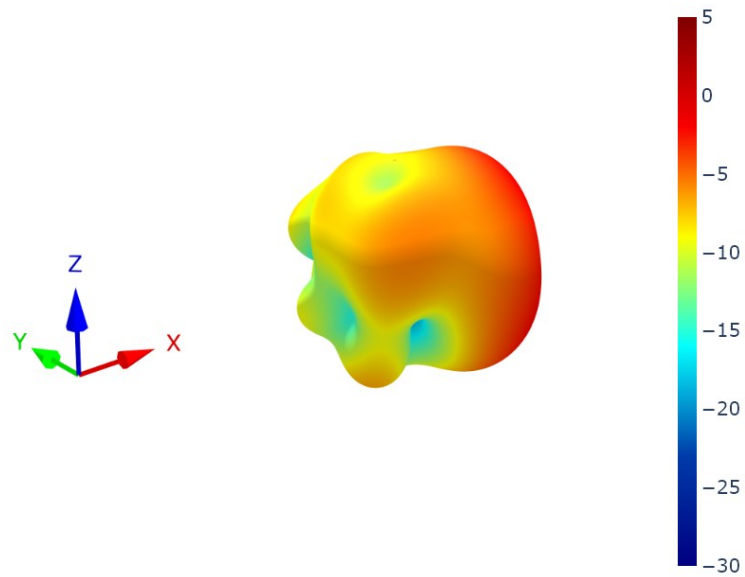

8.6 4G-5G 3 Patterns at 652 MHz

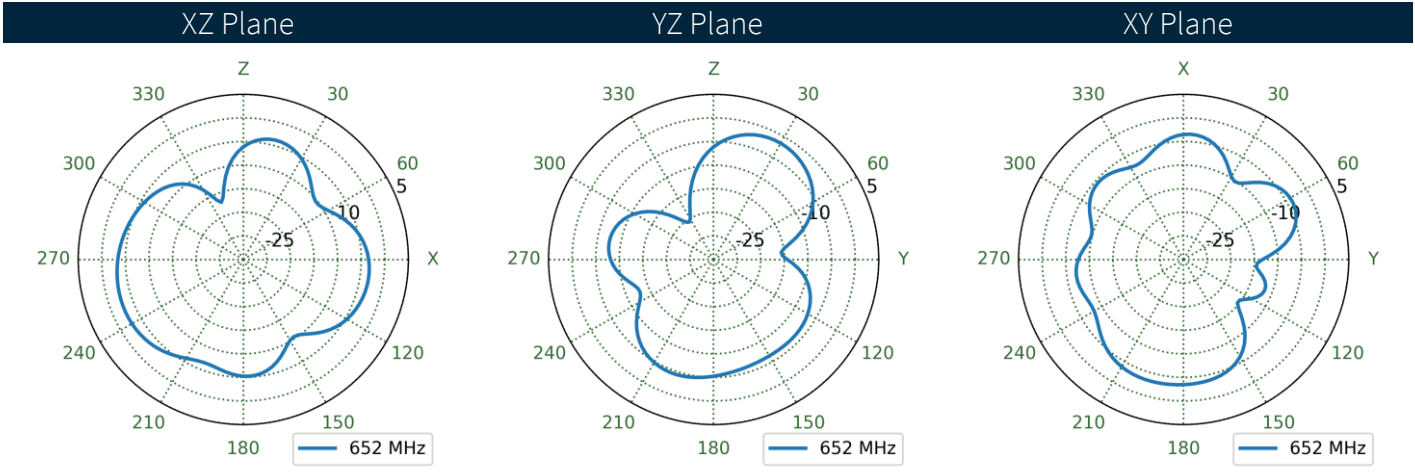
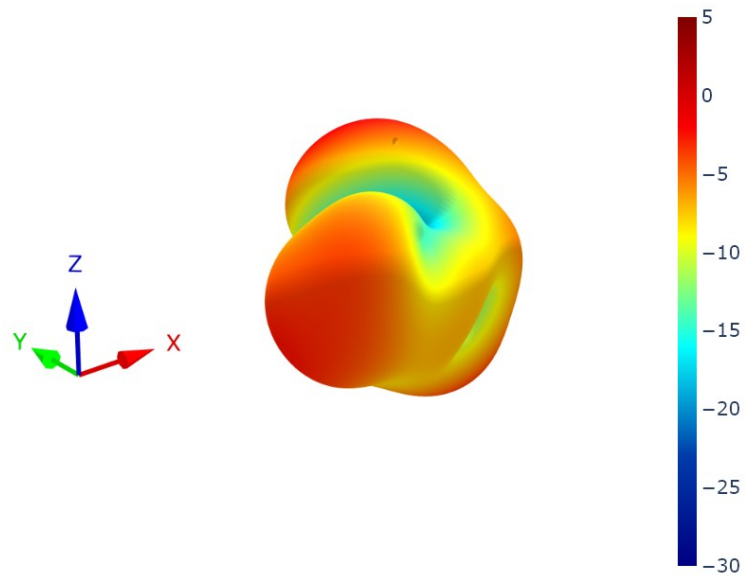

8.7 4G-5G 4 Patterns at 652 MHz

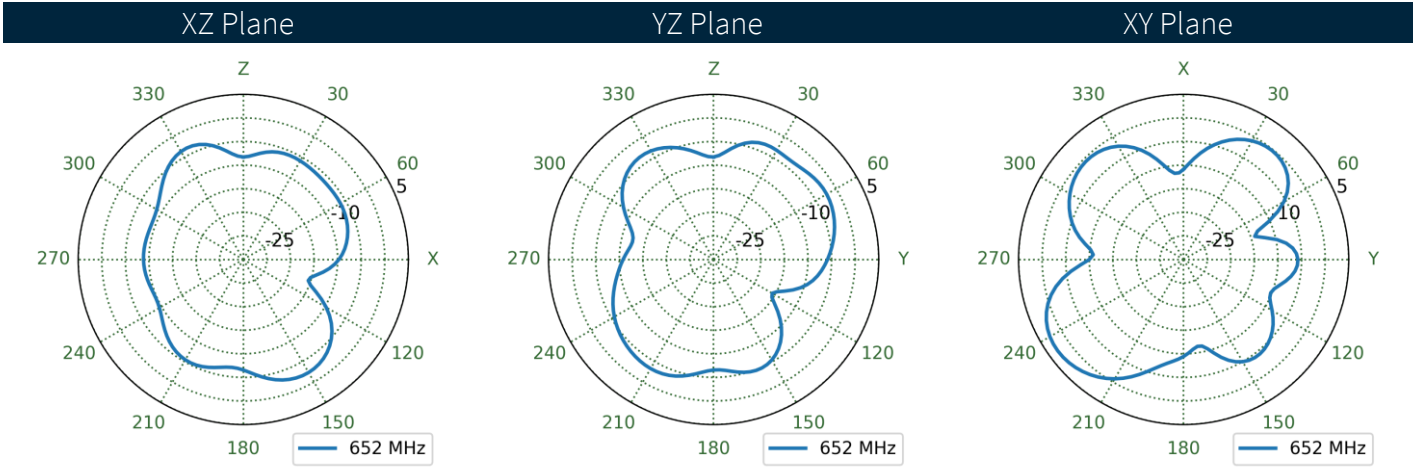
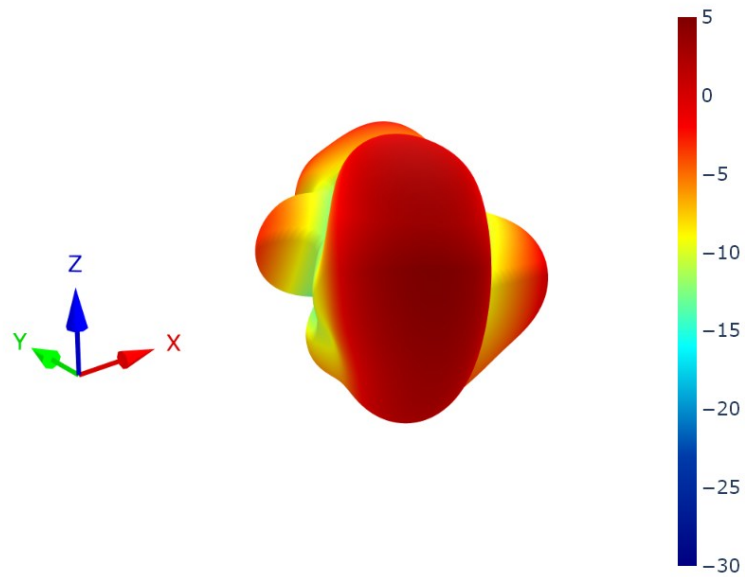

8.8 4G-5G 5 Patterns at 652 MHz

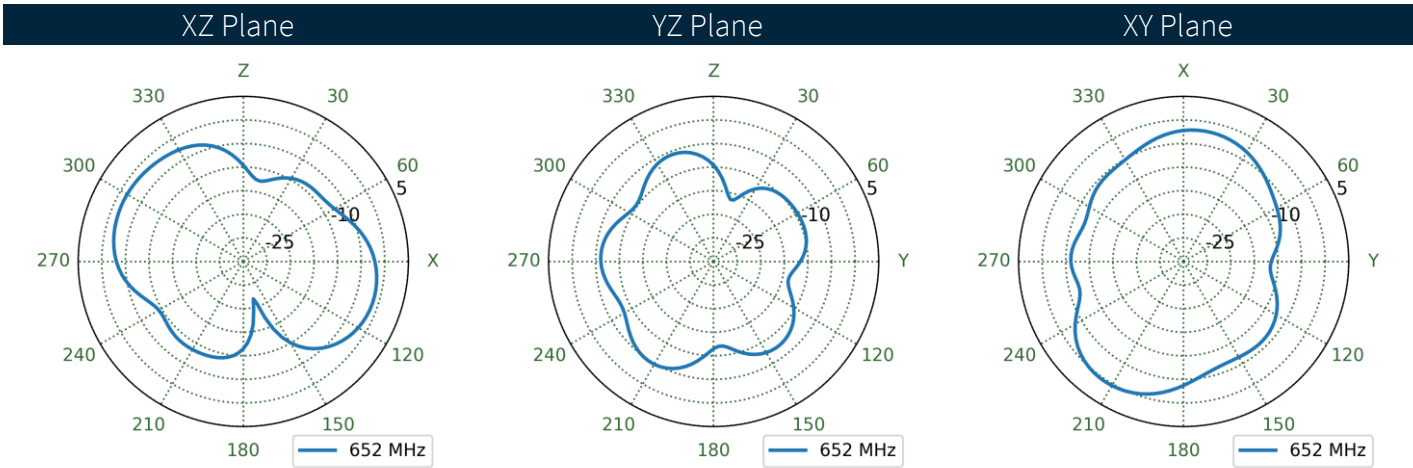
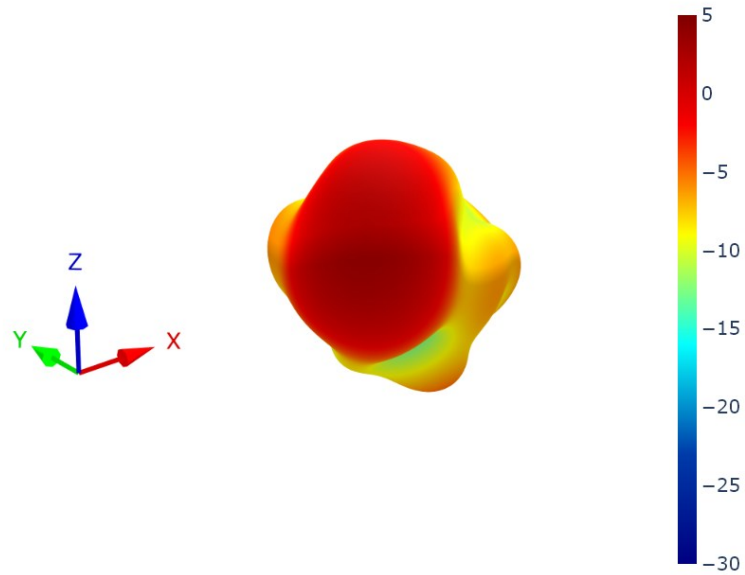

8.9 4G-5G 6 Patterns at 652 MHz

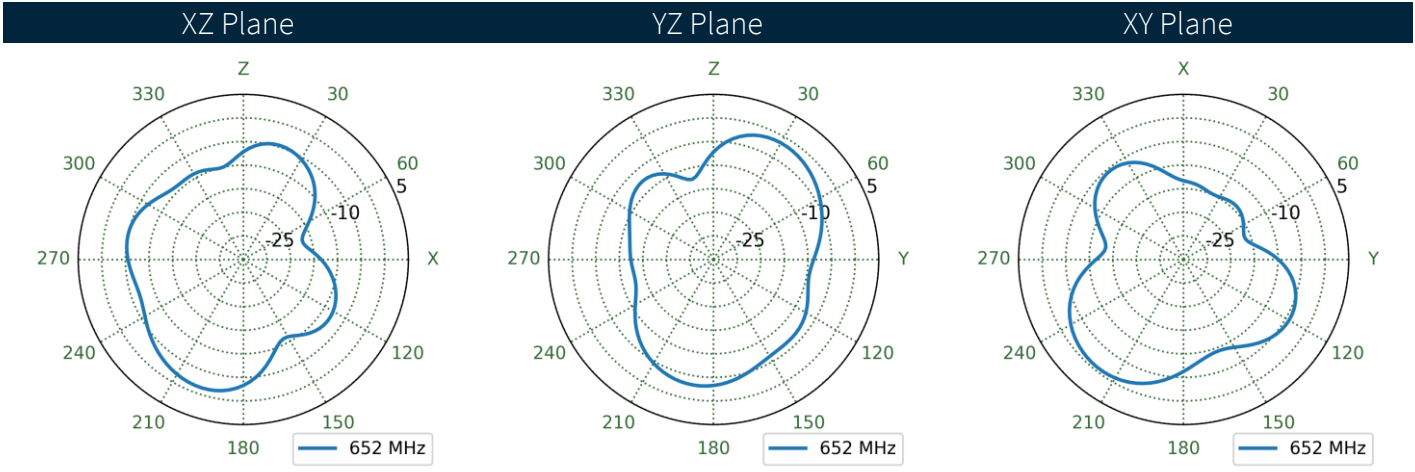
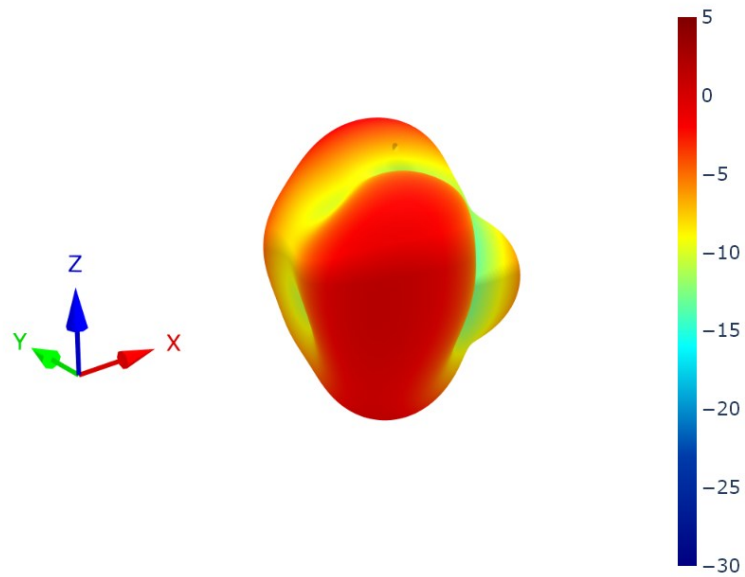

8.10 4G-5G 7 Patterns at 652 MHz

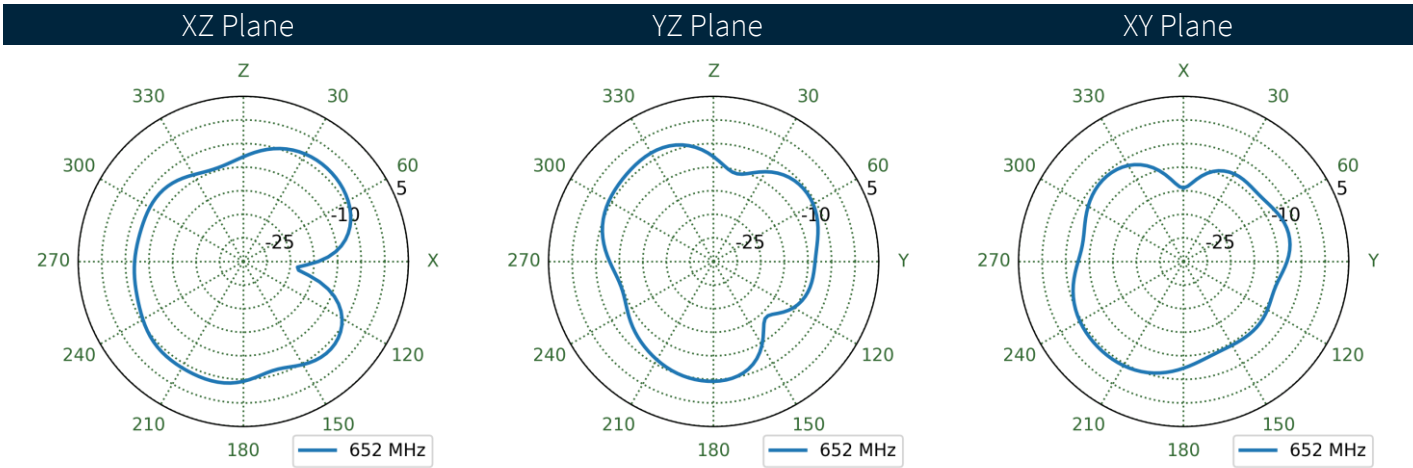
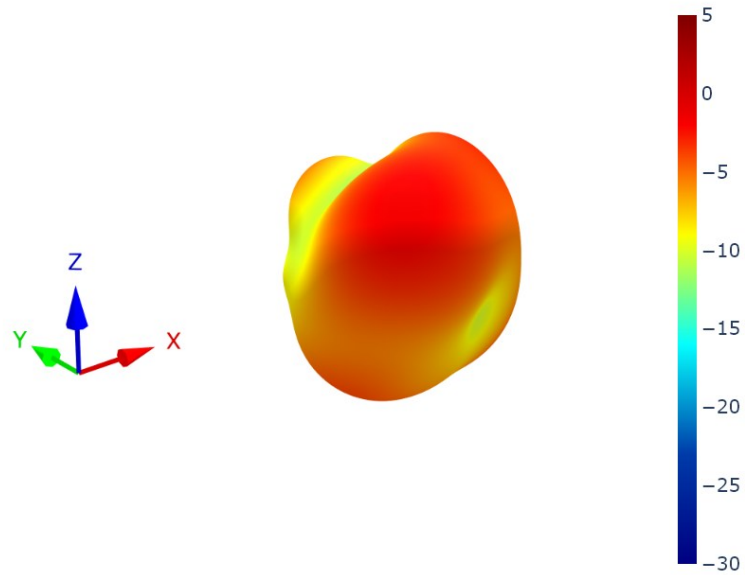

8.11 4G-5G 8 Patterns at 652 MHz

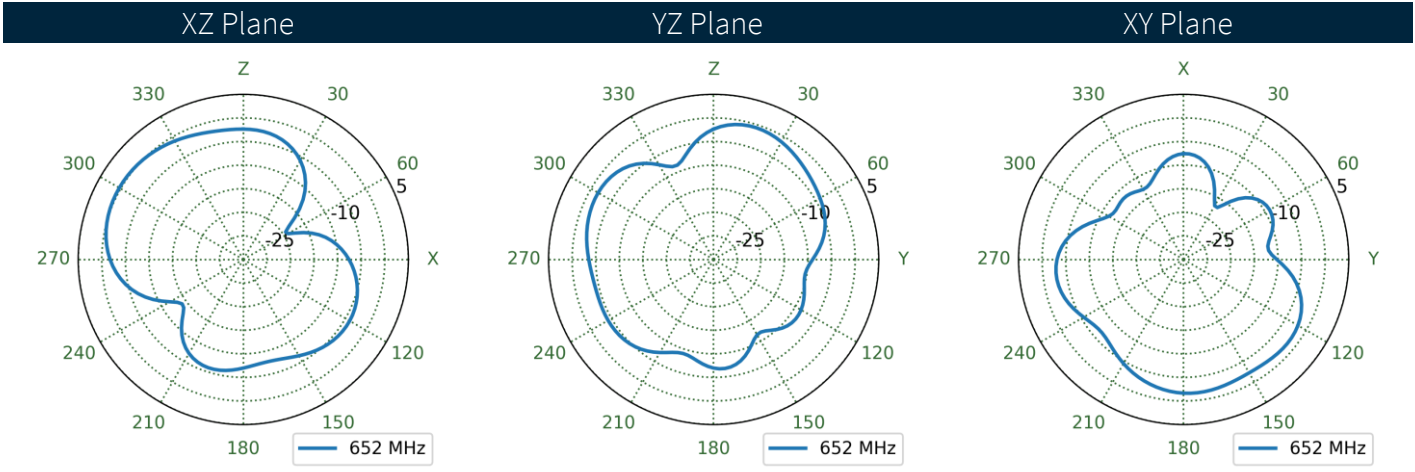
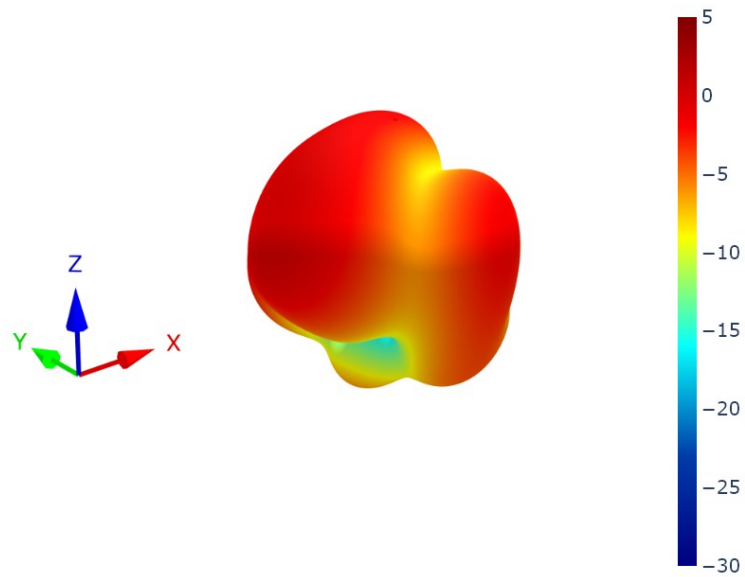

8.12 4G-5G 1 Patterns at 751 MHz

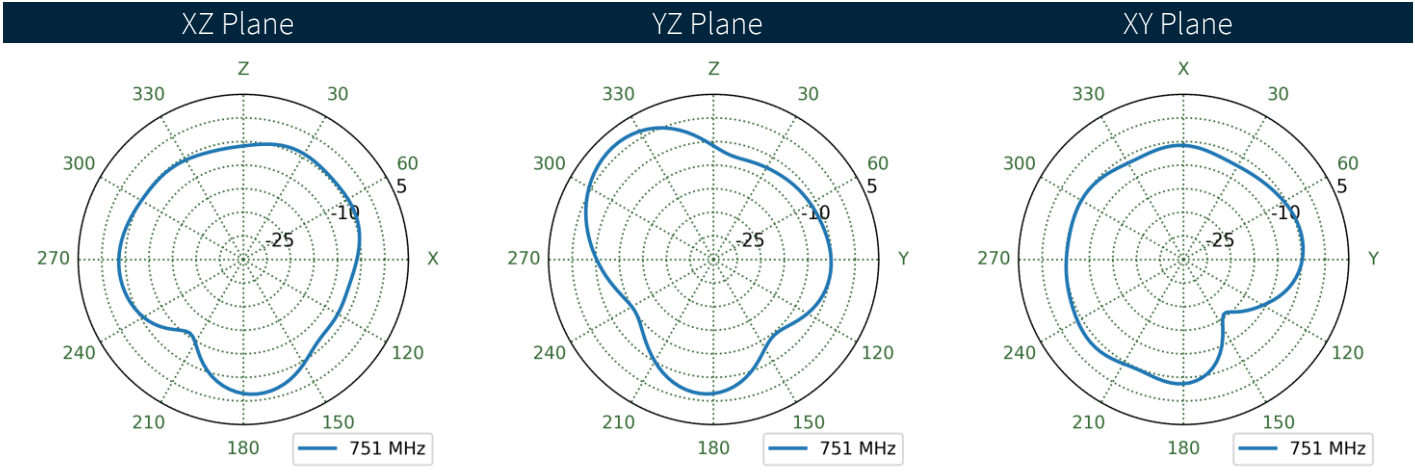
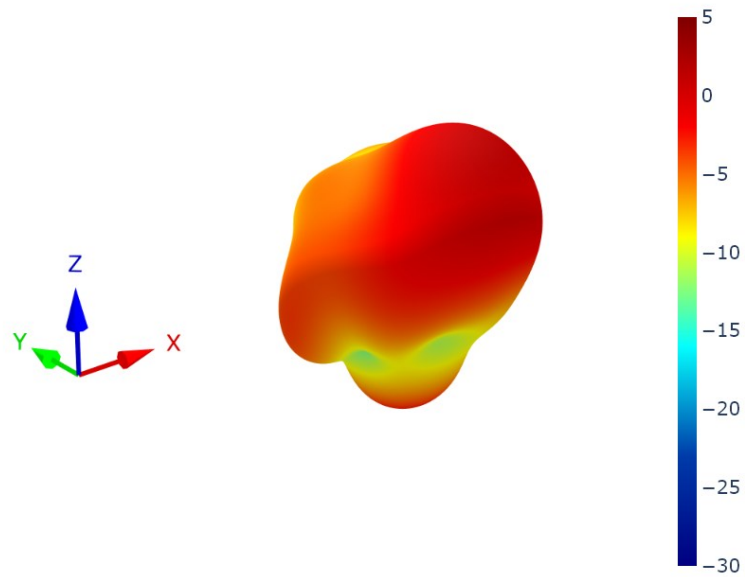

8.13 4G-5G 2 Patterns at 751 MHz

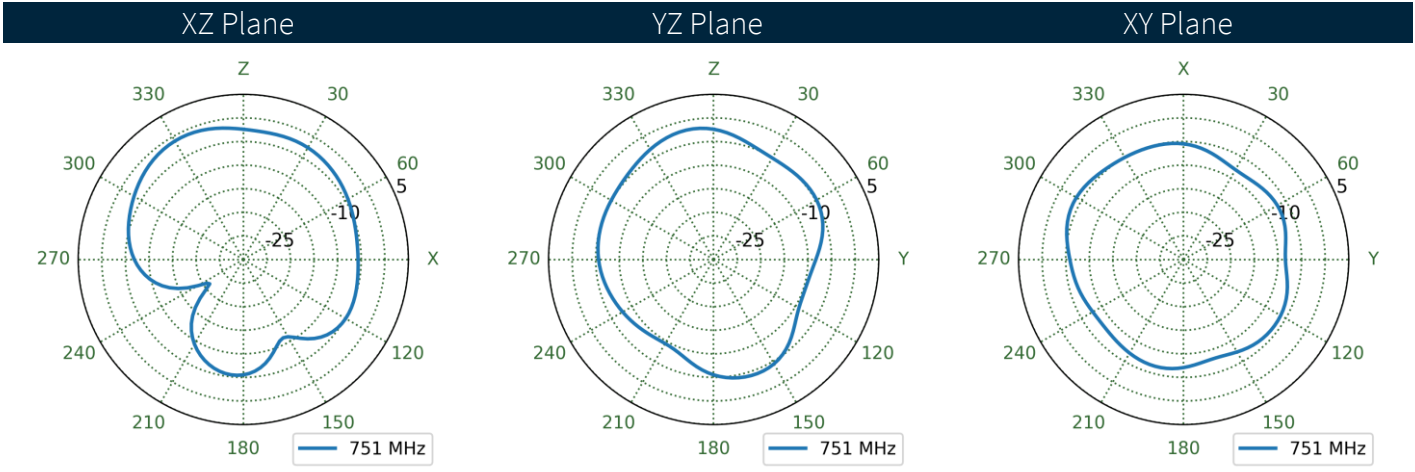
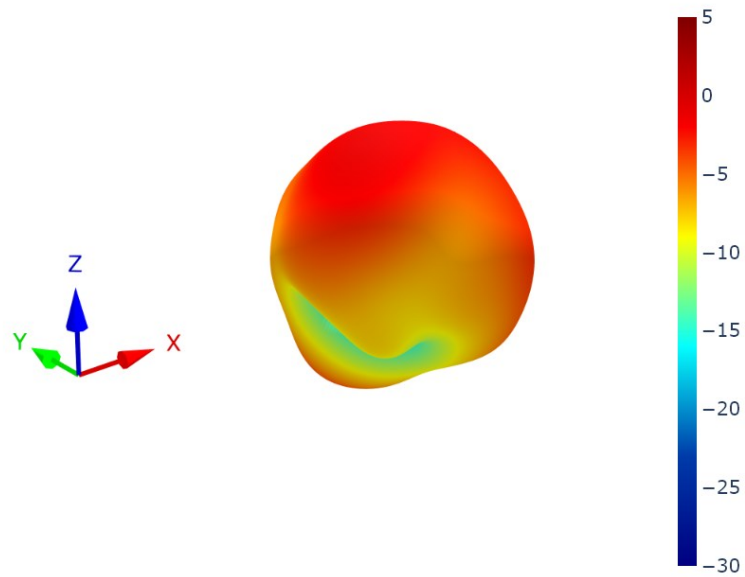

8.14 4G-5G 3 Patterns at 751 MHz

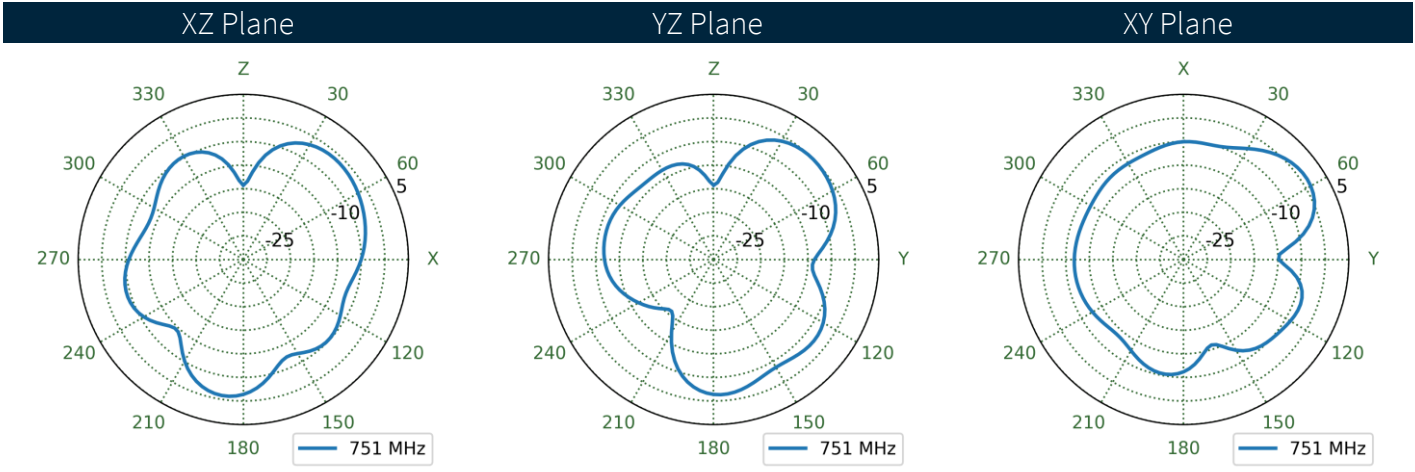
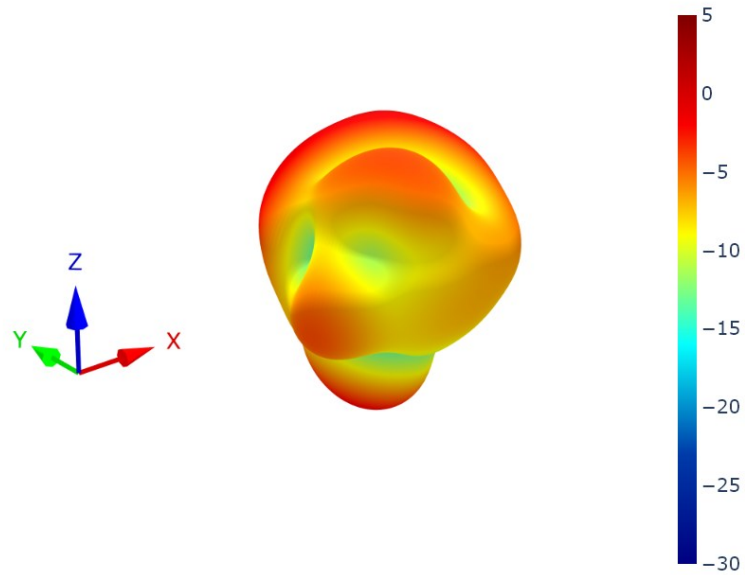

8.15 4G-5G 4 Patterns at 751 MHz

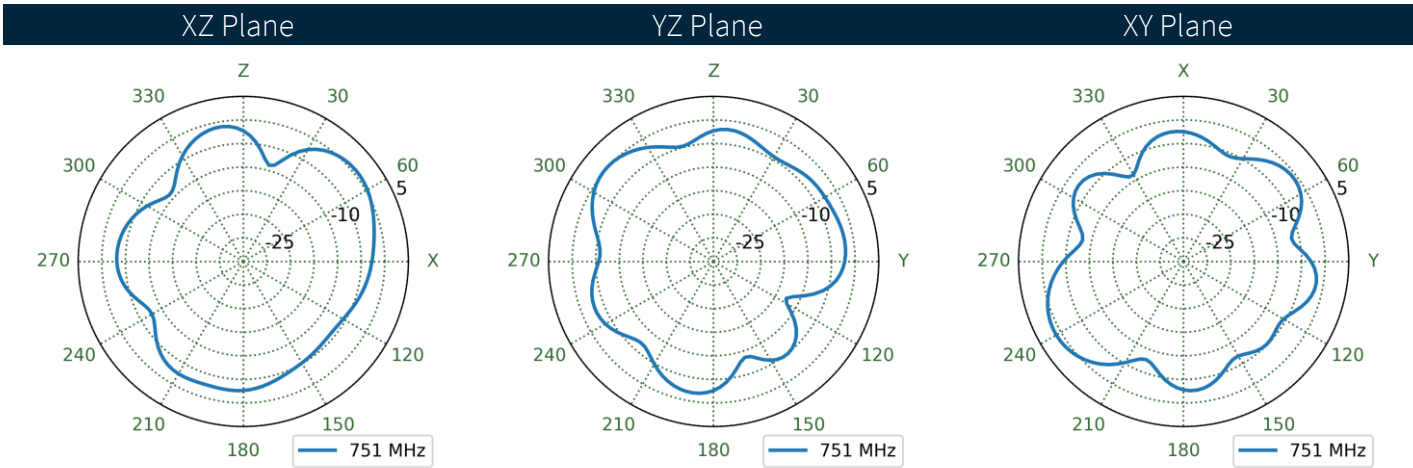
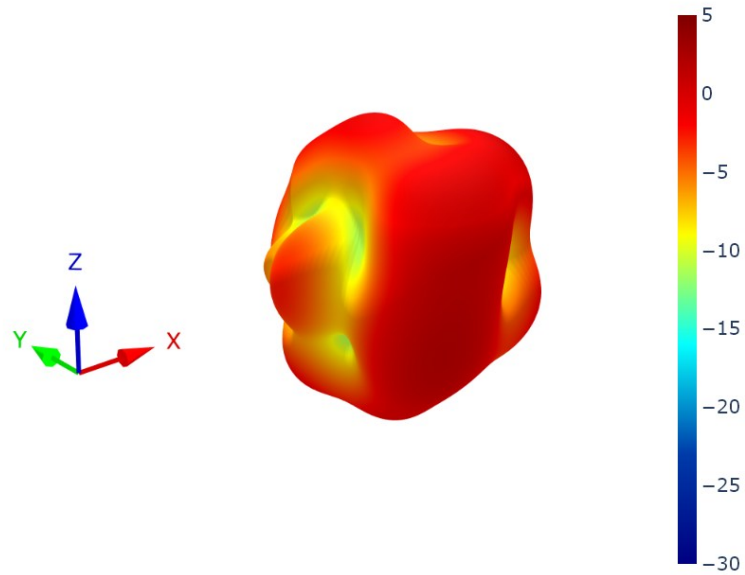

8.16 4G-5G 5 Patterns at 751 MHz

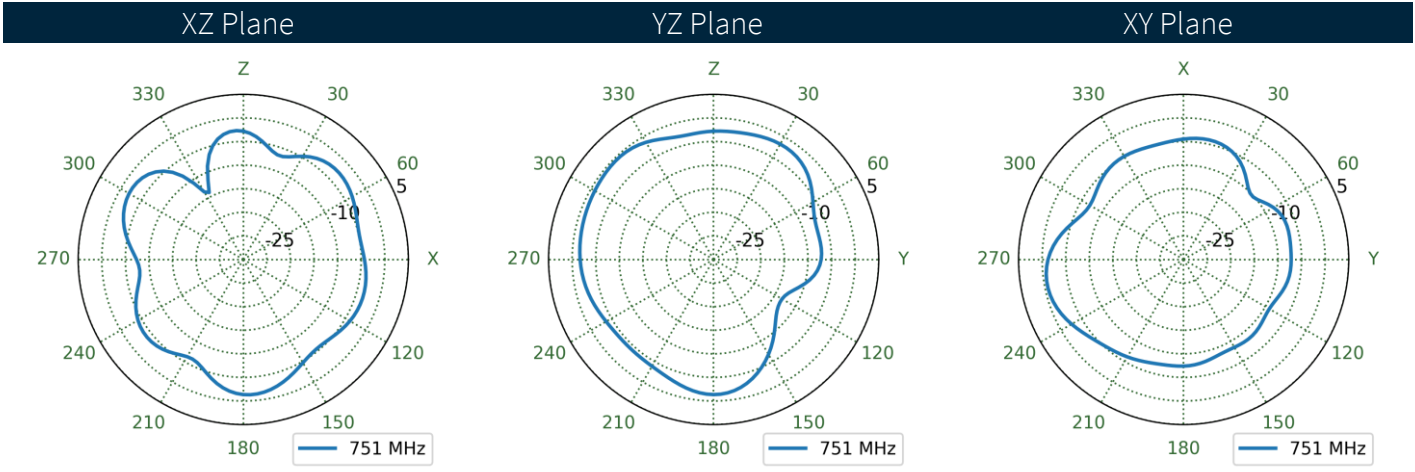
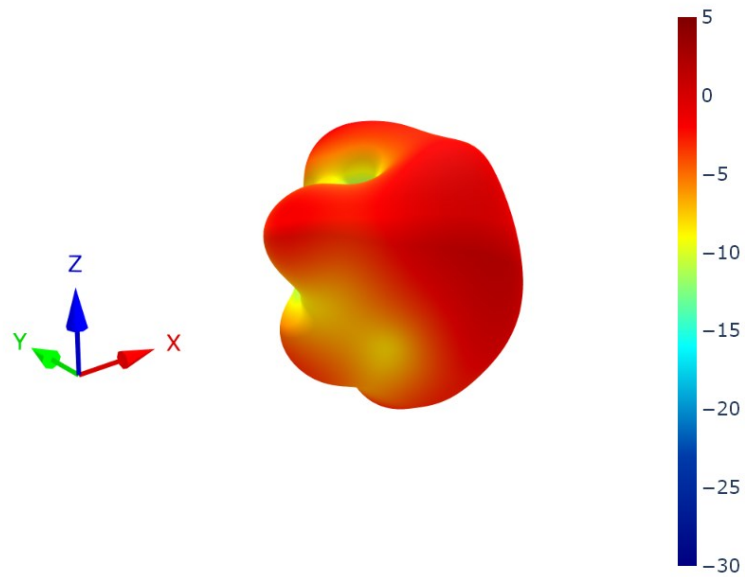

8.17 4G-5G 6 Patterns at 751 MHz

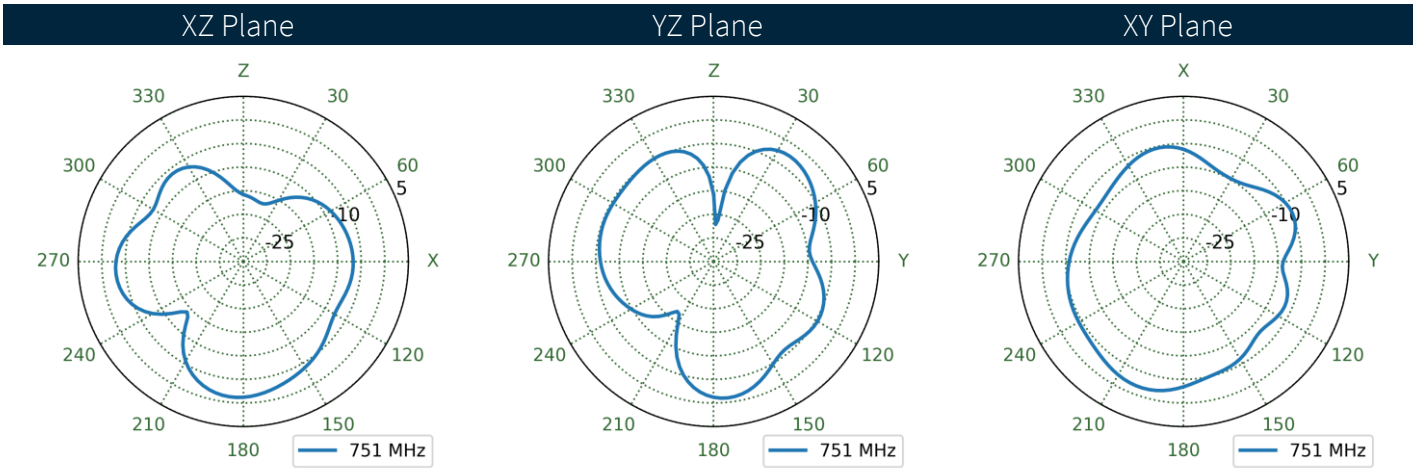
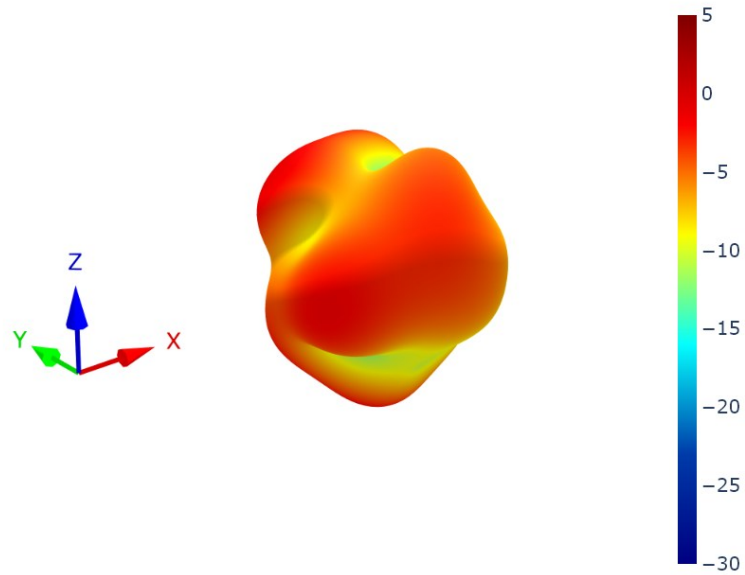

8.18 4G-5G 7 Patterns at 751 MHz

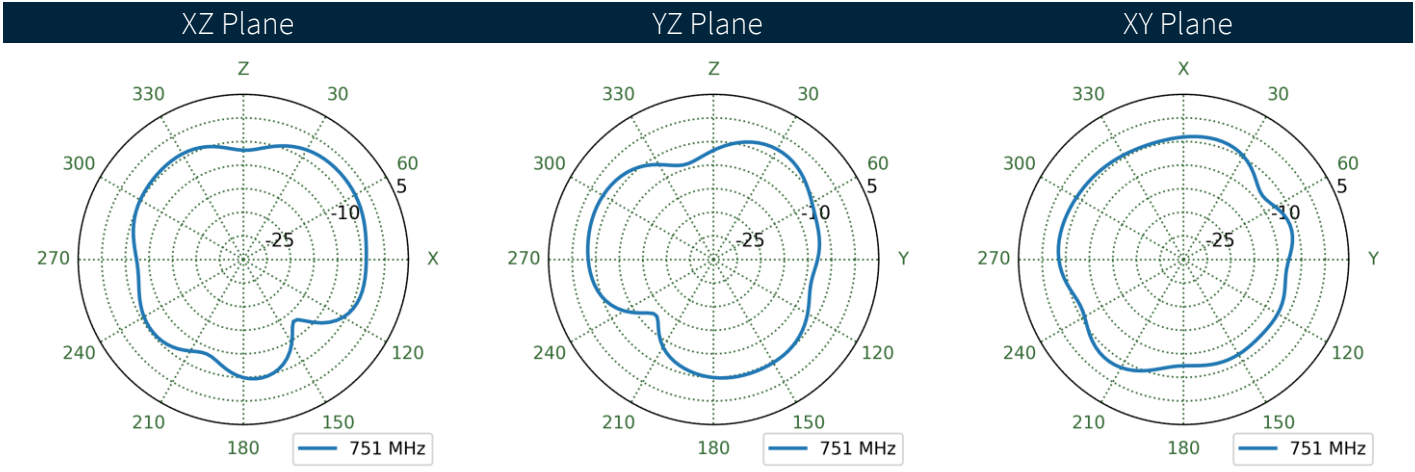
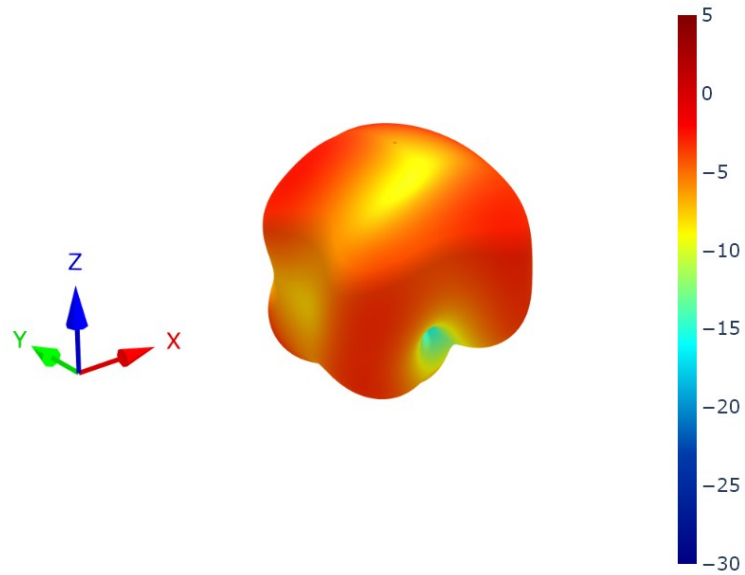

8.19 4G-5G 8 Patterns at 751 MHz

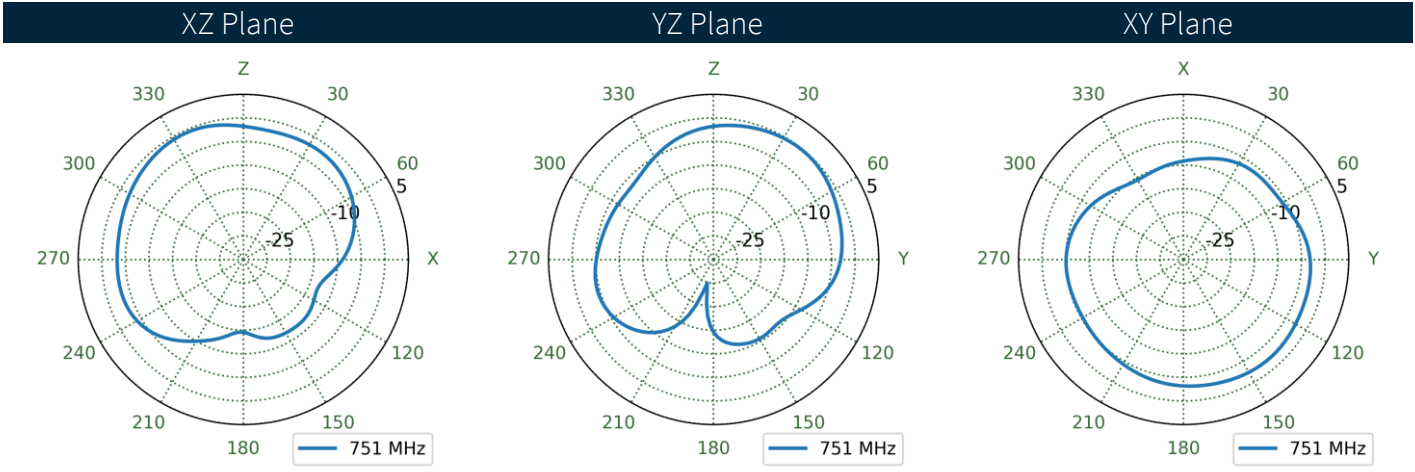
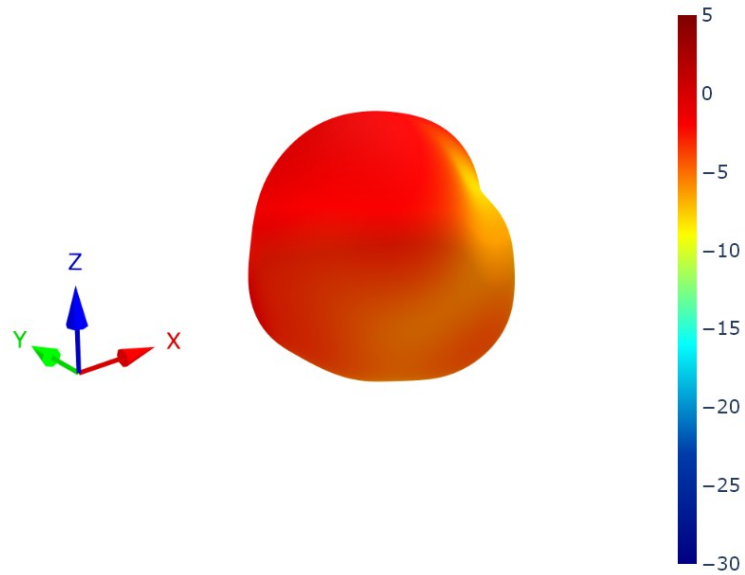

8.20 4G-5G 1 Patterns at 890 MHz

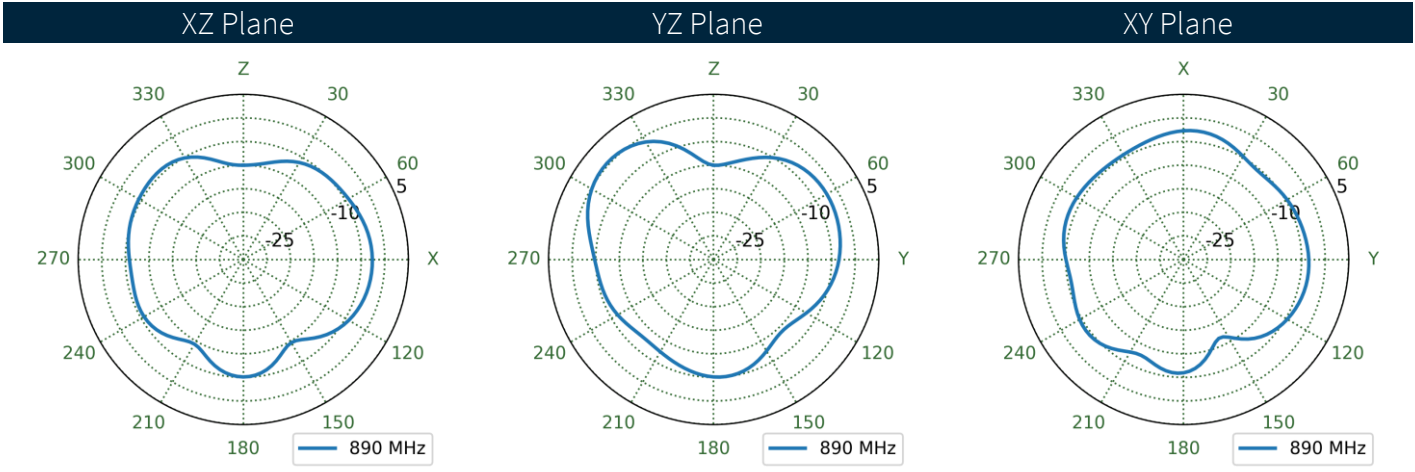
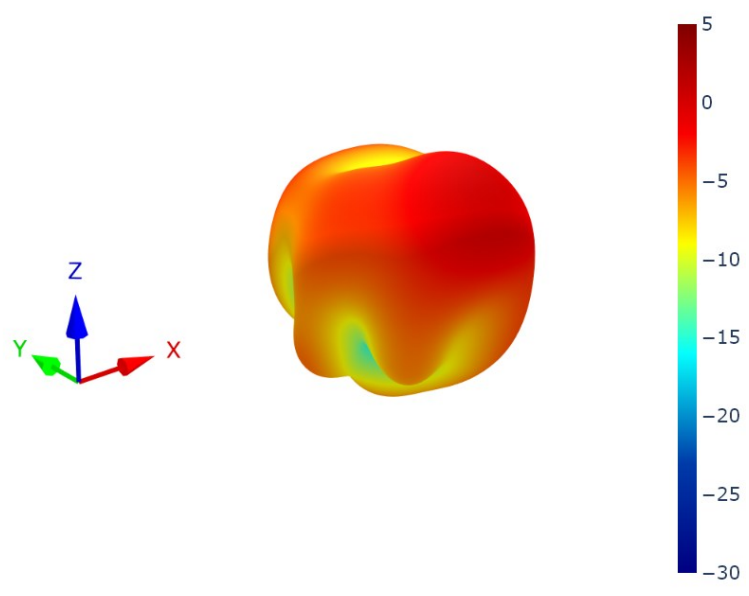

8.21 4G-5G 2 Patterns at 890 MHz

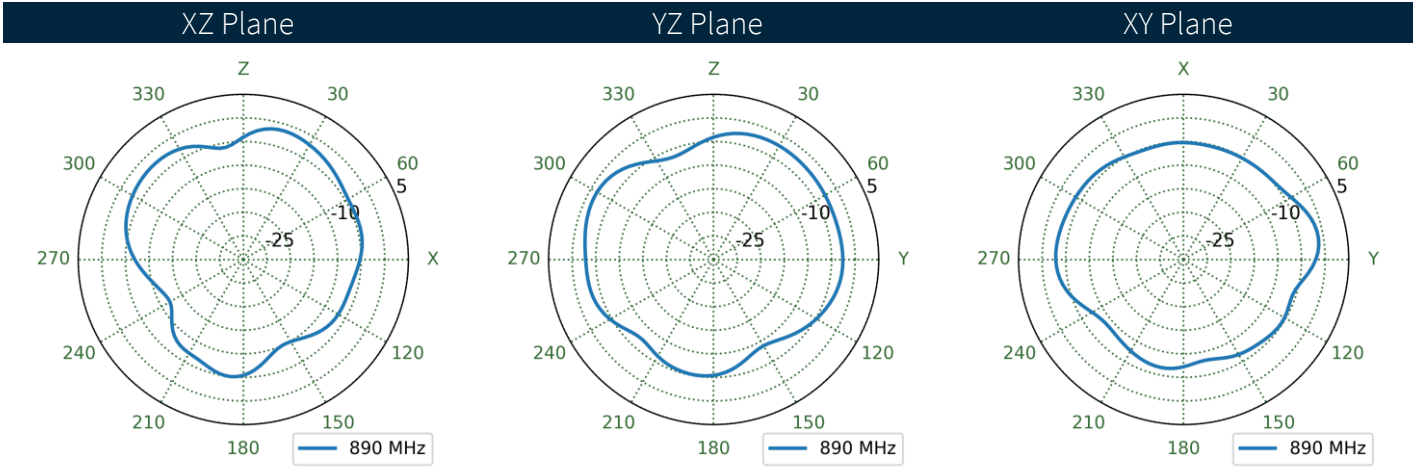
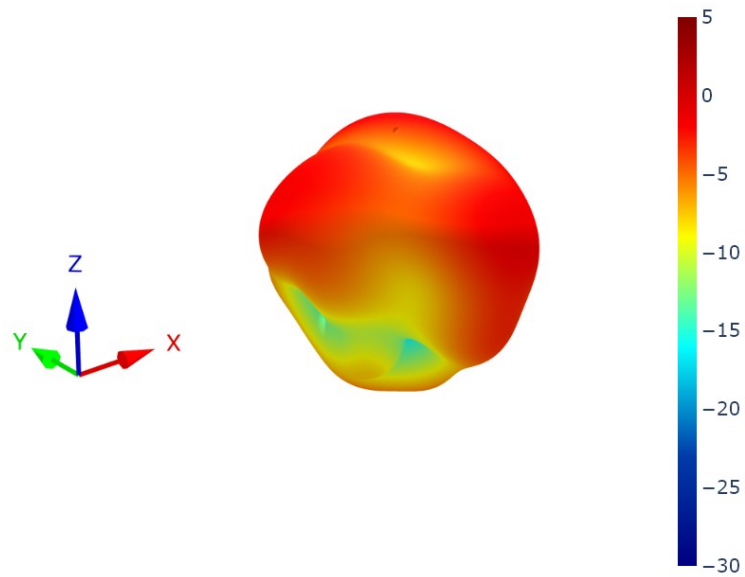

8.22 4G-5G 3 Patterns at 890 MHz

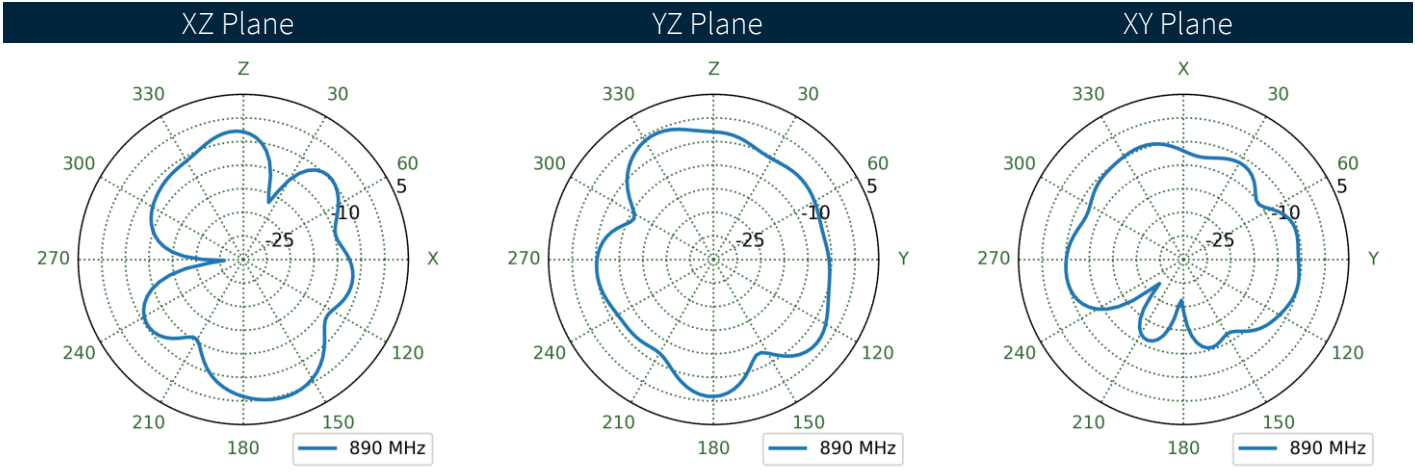
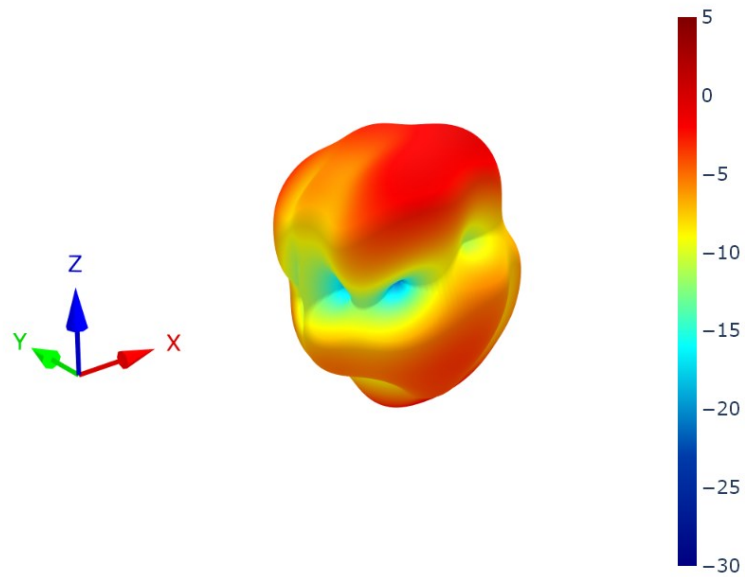

8.23 4G-5G 4 Patterns at 890 MHz

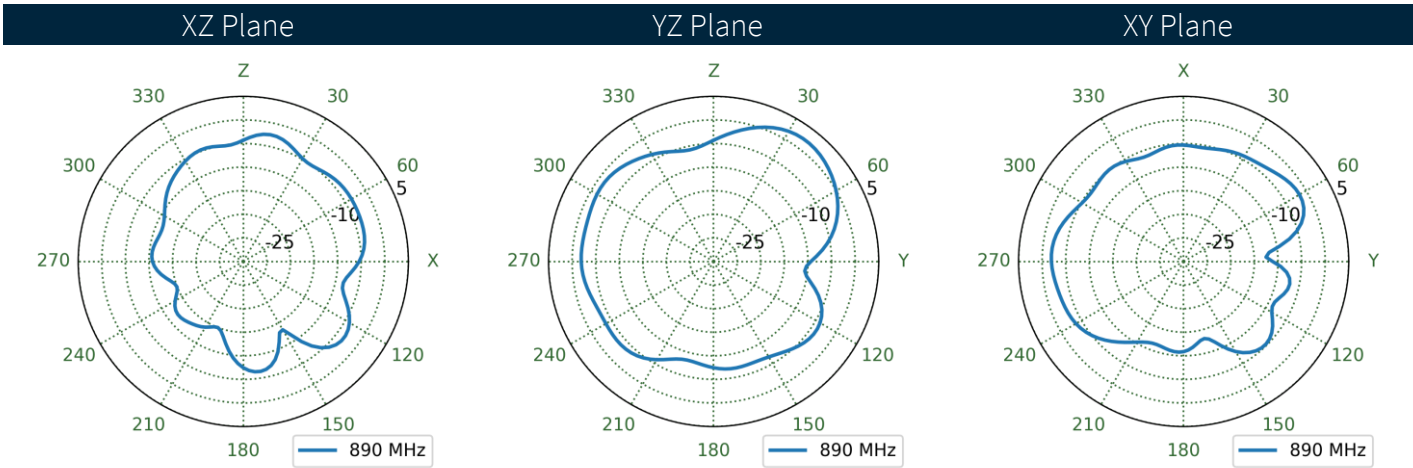
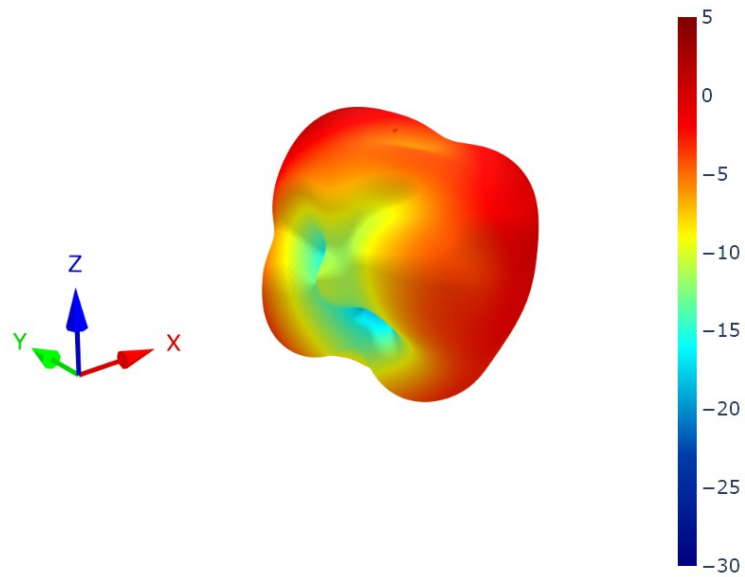

8.24 4G-5G 5 Patterns at 890 MHz

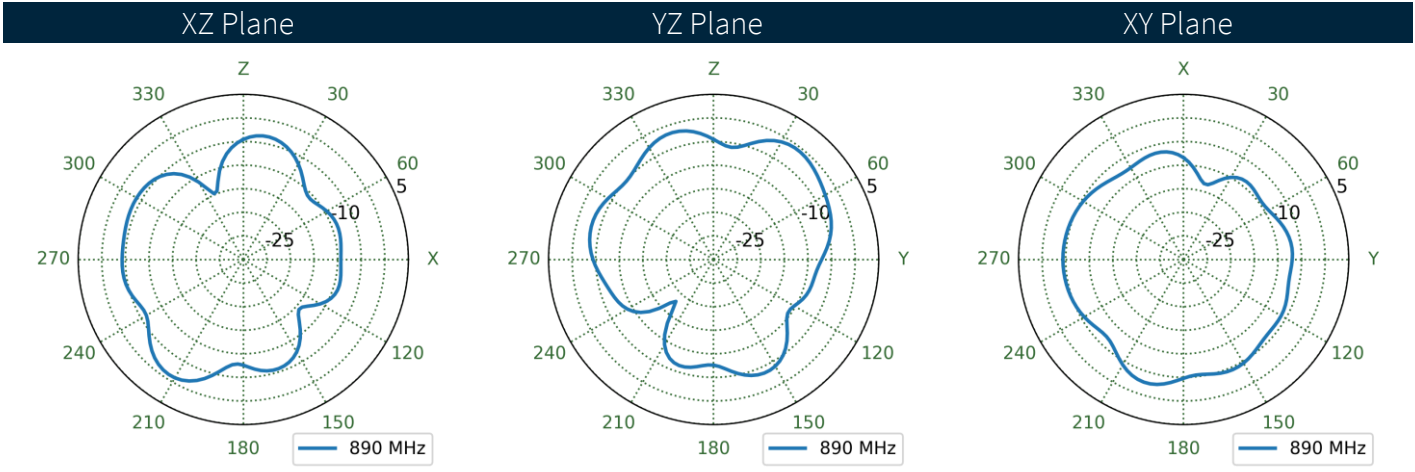
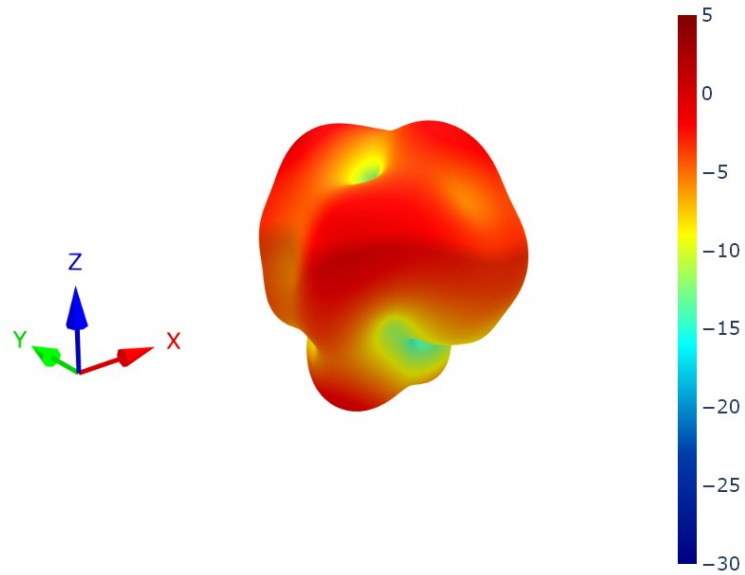

8.25 4G-5G 6 Patterns at 890 MHz

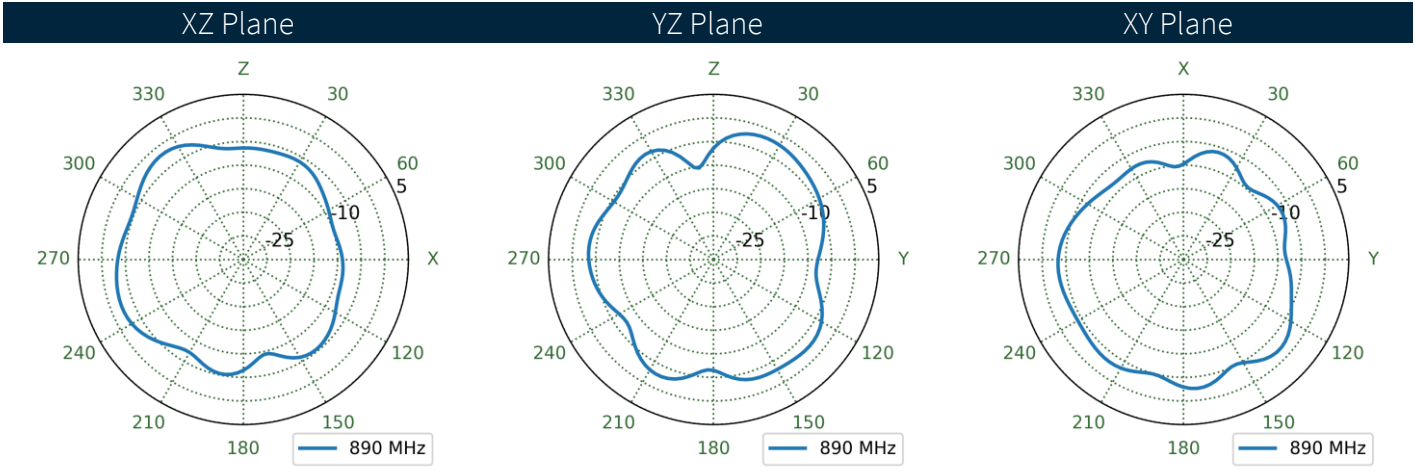
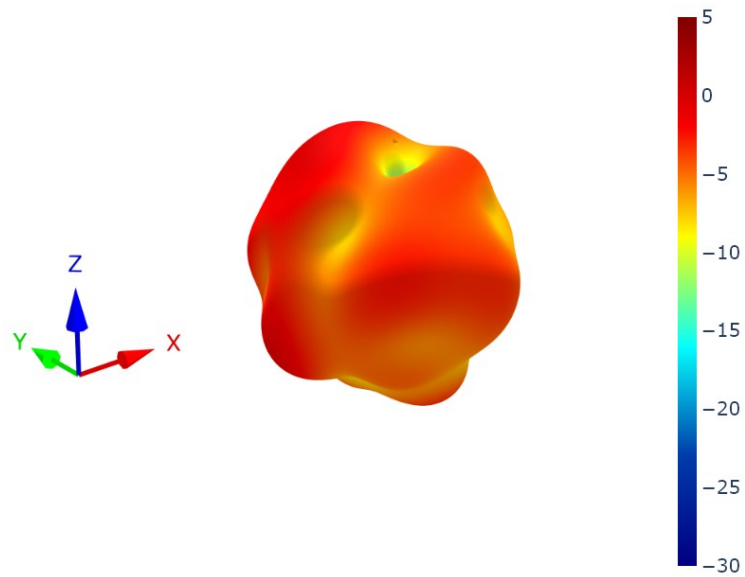

8.26 4G-5G 7 Patterns at 890 MHz

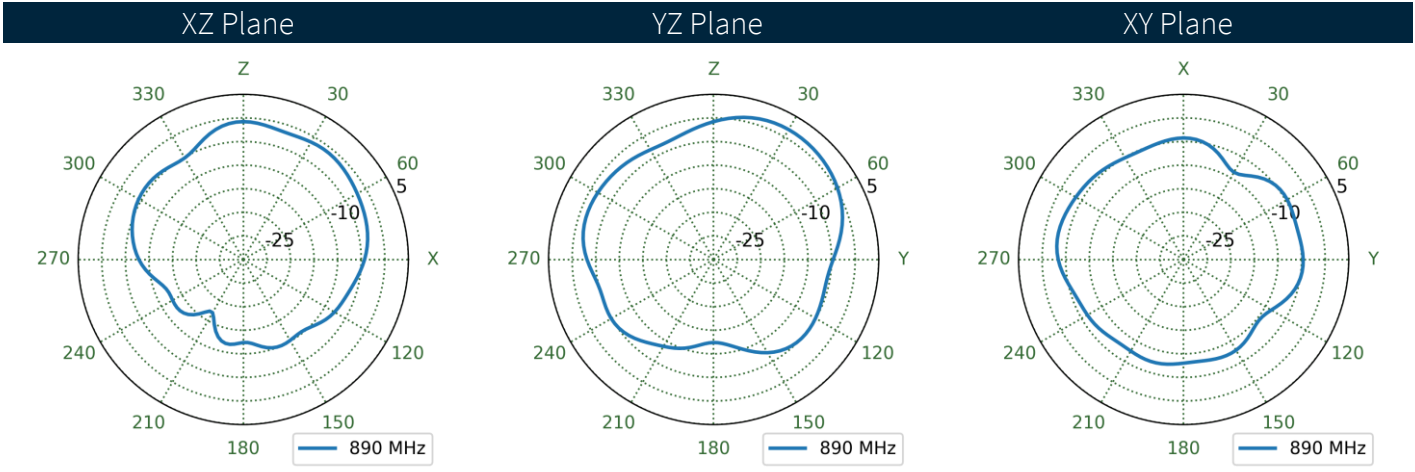
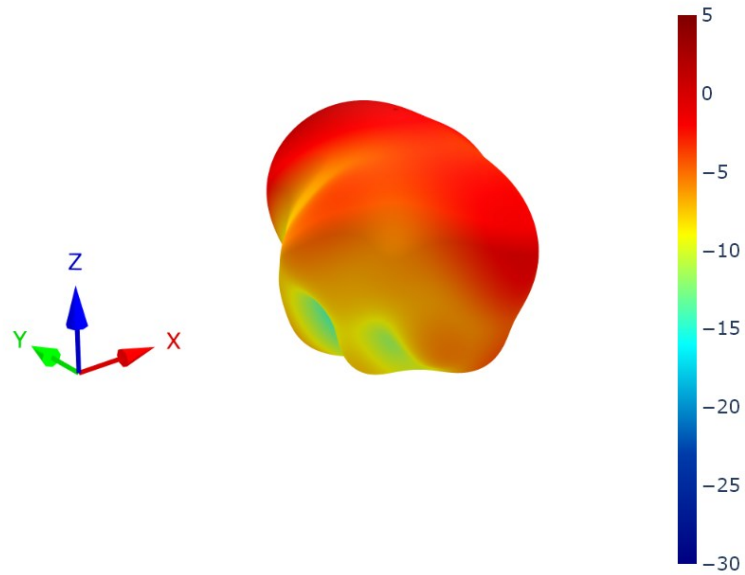

8.27 4G-5G 8 Patterns at 890 MHz

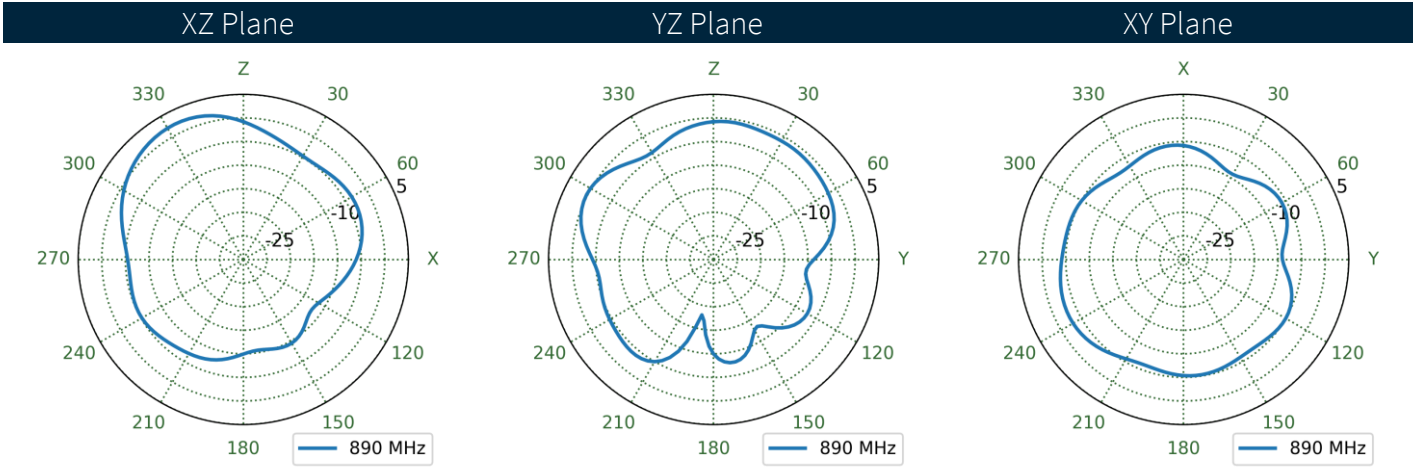
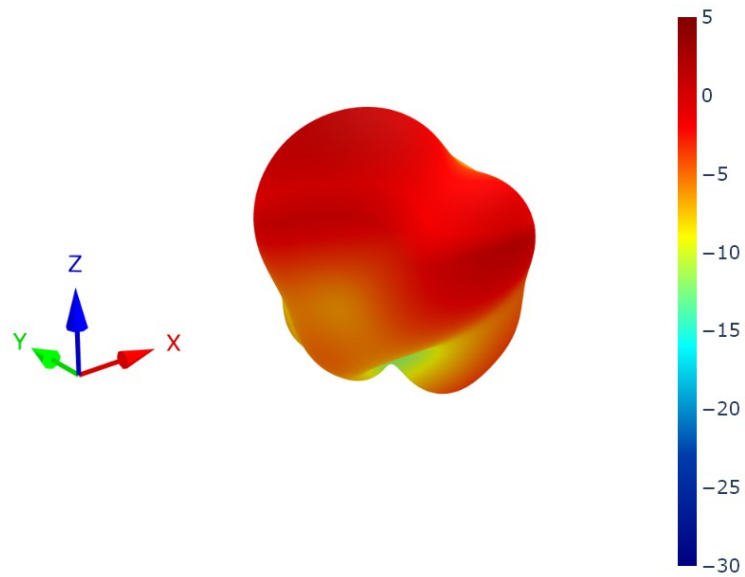

8.28 4G-5G 1 Patterns at 1470 MHz

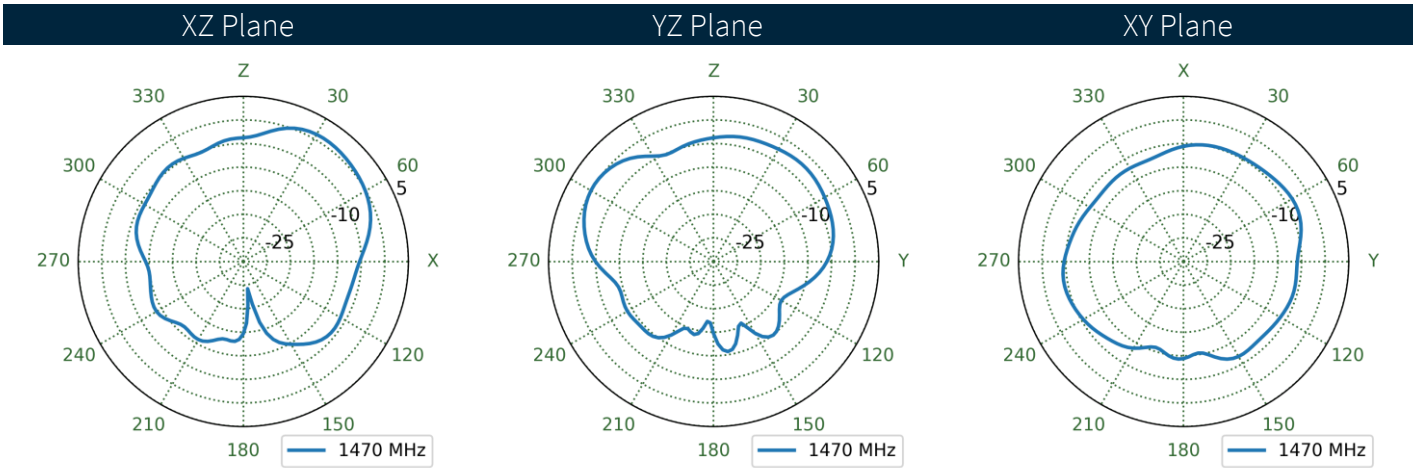
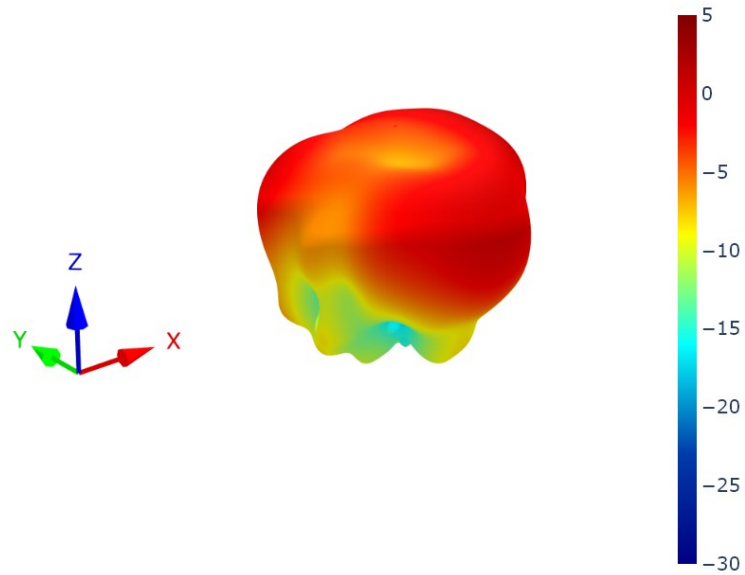

8.29 4G-5G 2 Patterns at 1470 MHz

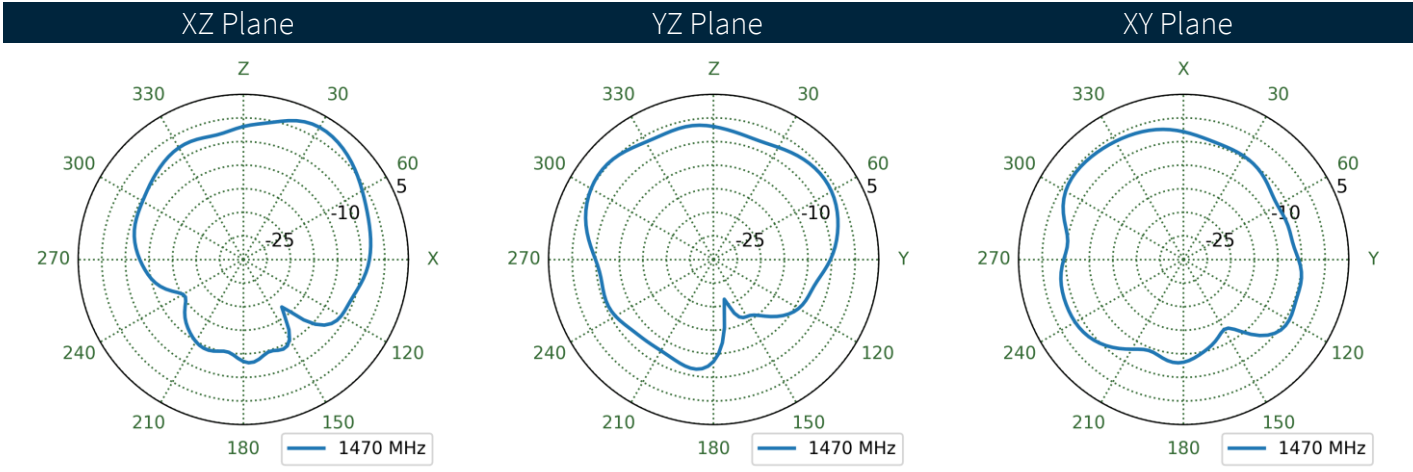
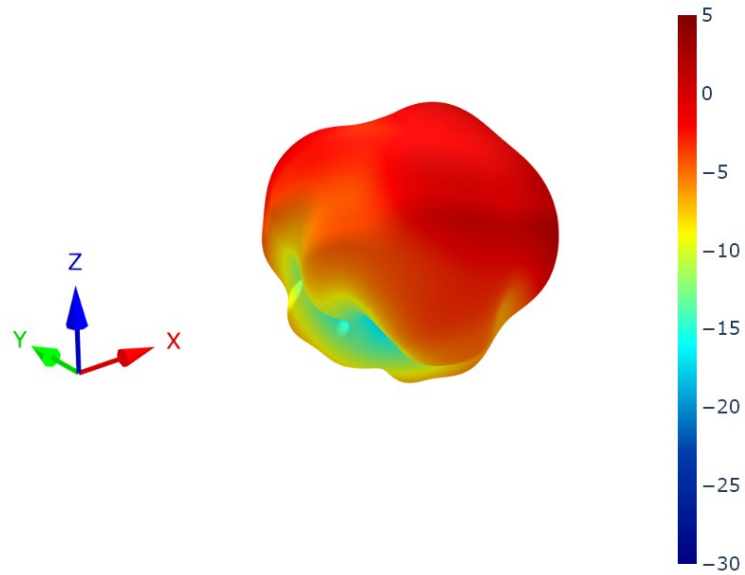

8.30 4G-5G 3 Patterns at 1470 MHz

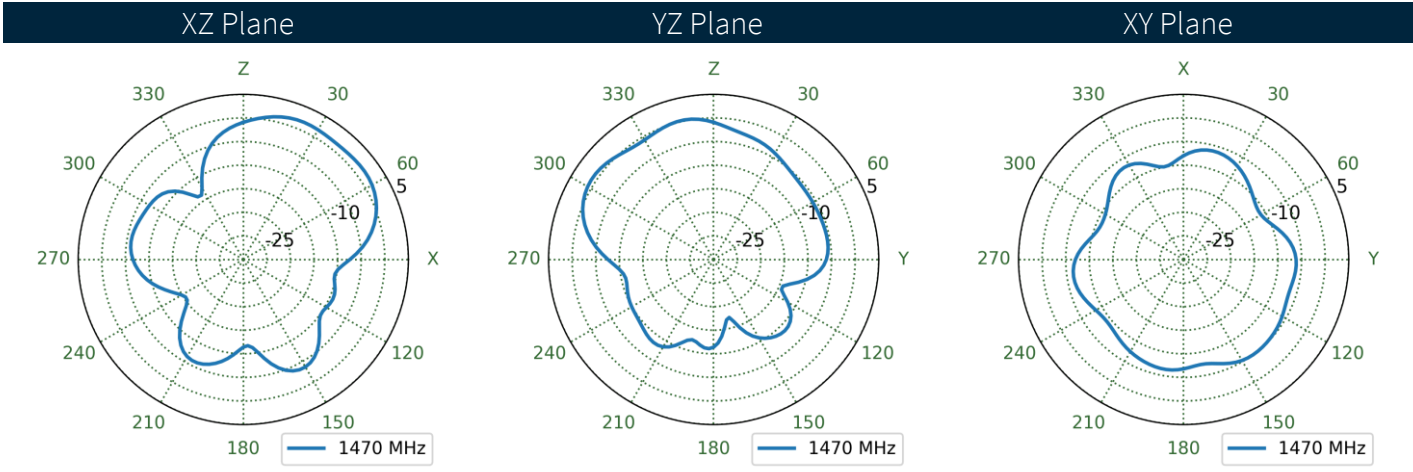
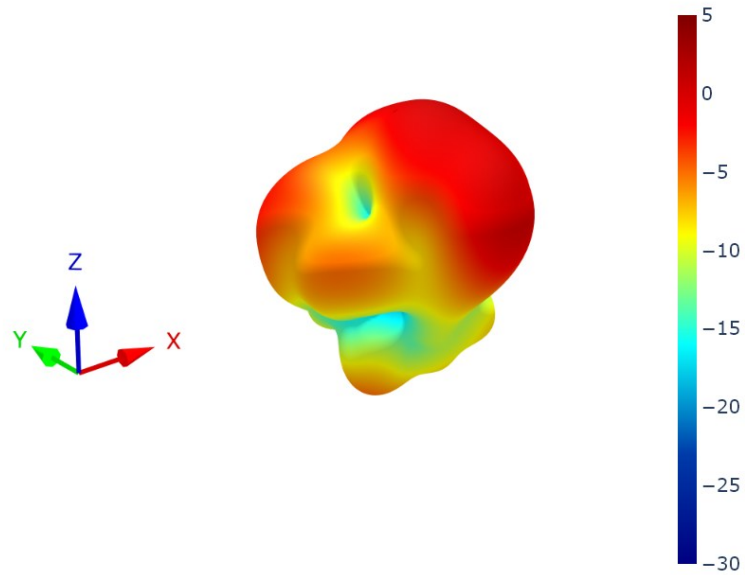

8.31 4G-5G 4 Patterns at 1470 MHz

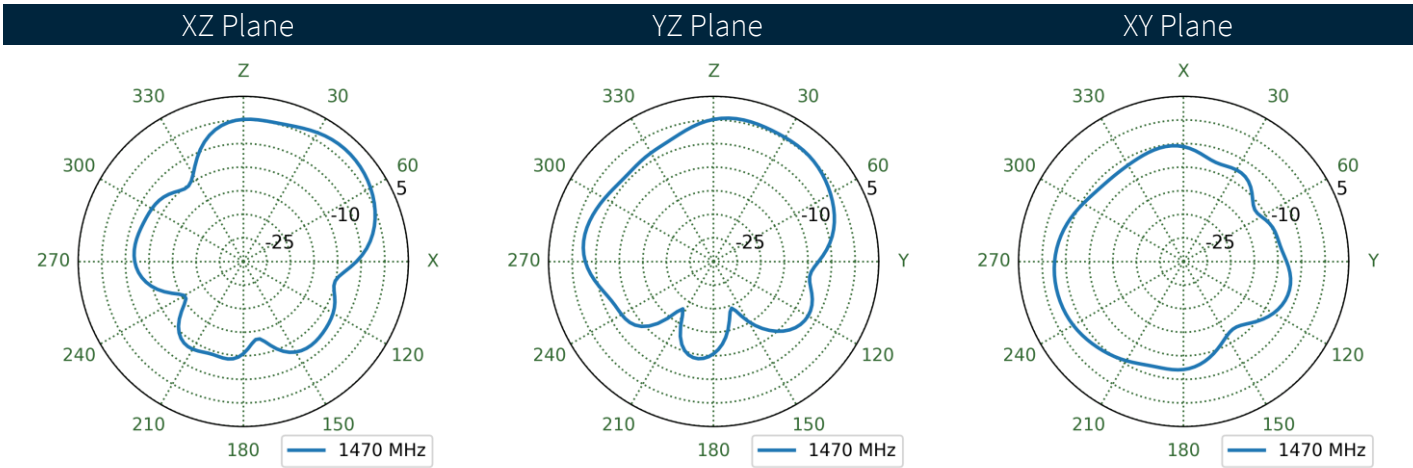
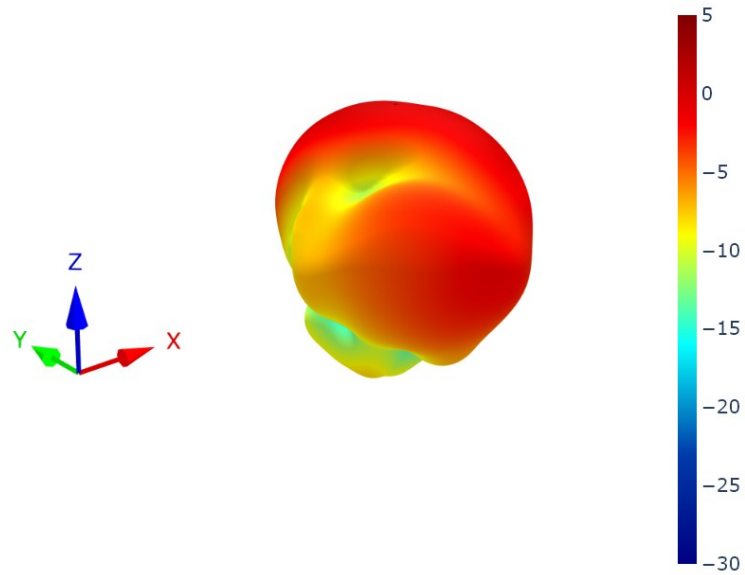

8.32 4G-5G 5 Patterns at 1470 MHz

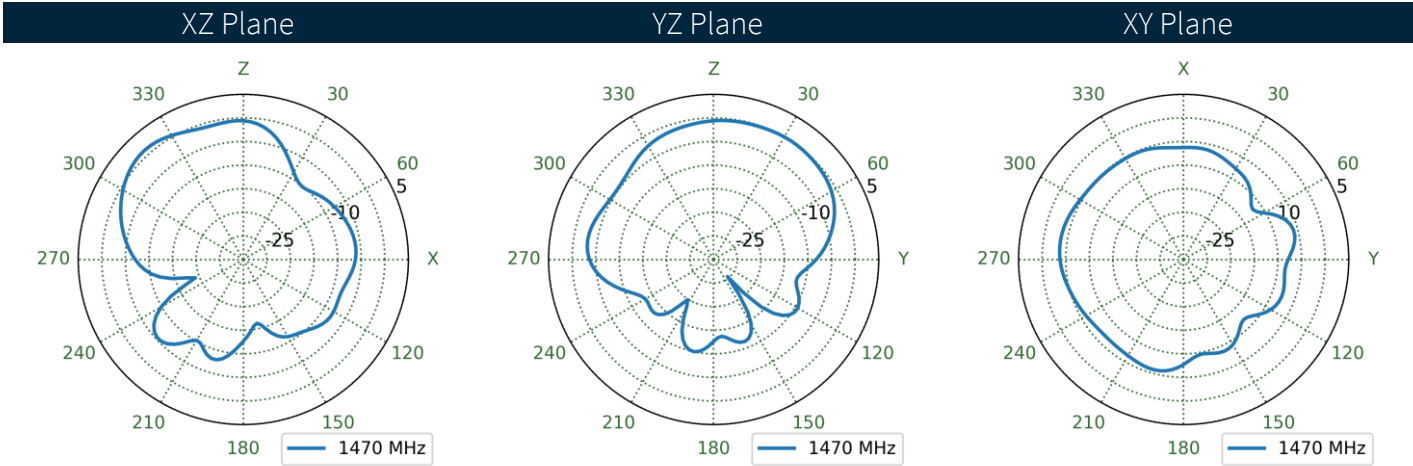
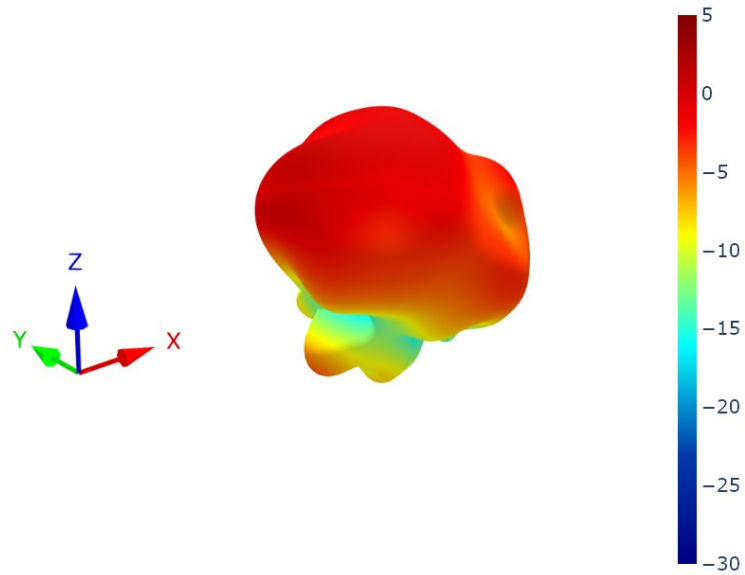

8.33 4G-5G 6 Patterns at 1470 MHz

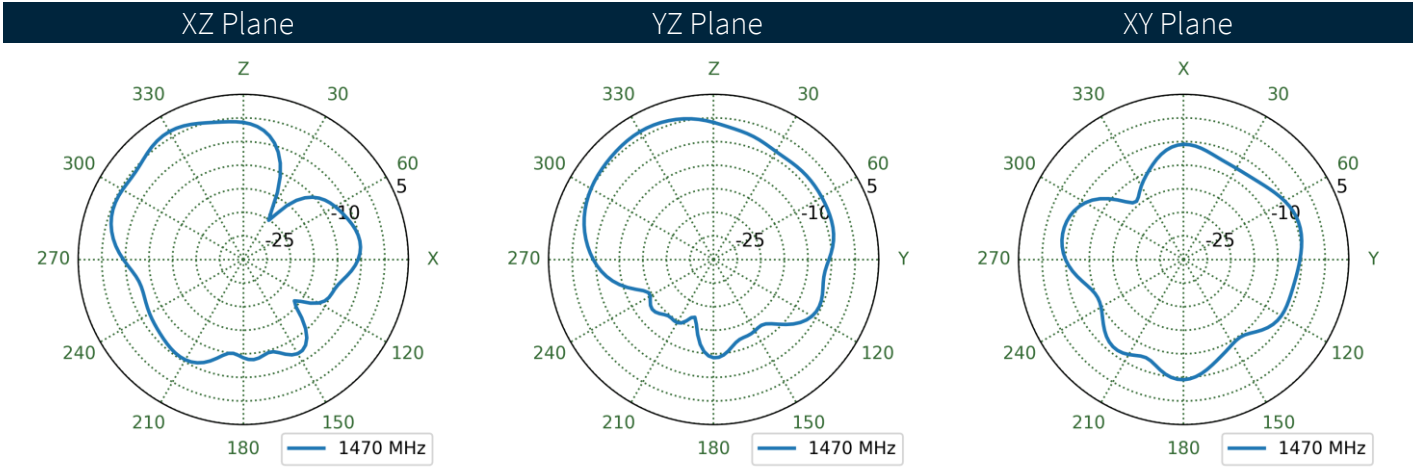
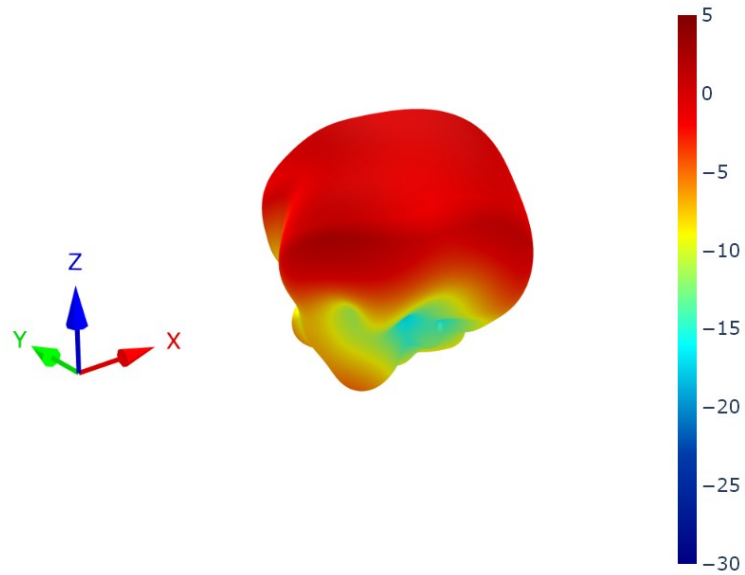

8.34 4G-5G 7 Patterns at 1470 MHz

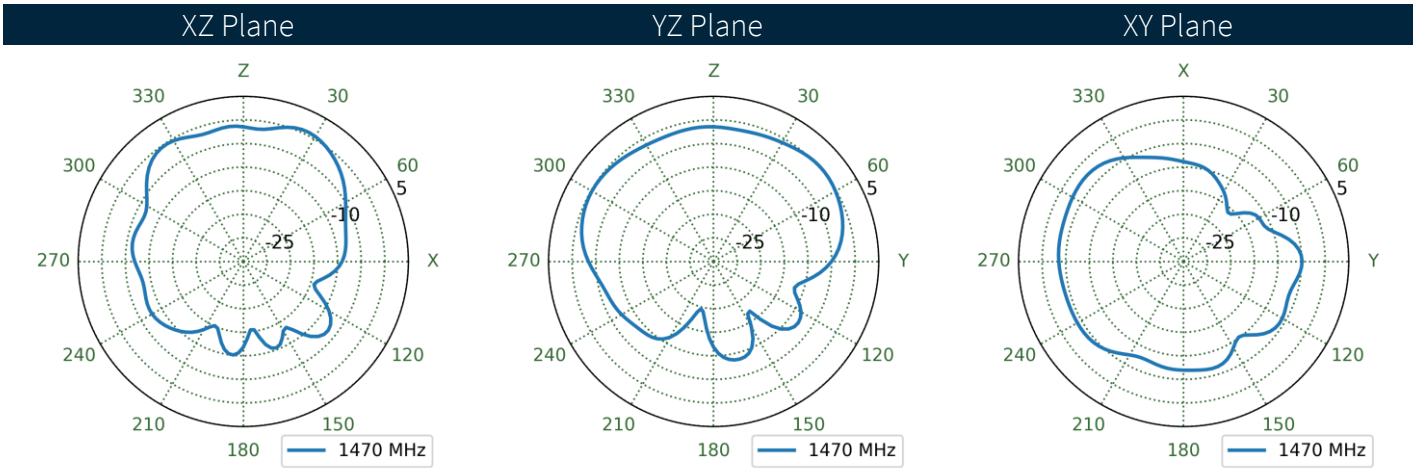
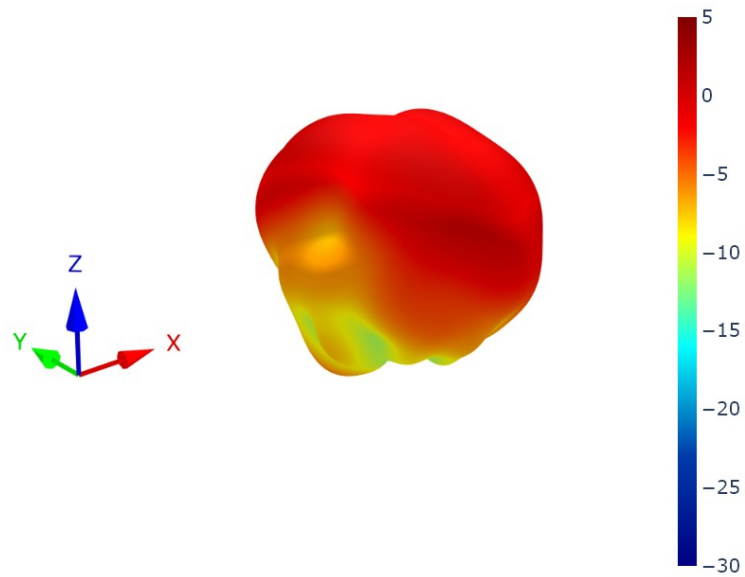

8.35 4G-5G 8 Patterns at 1470 MHz

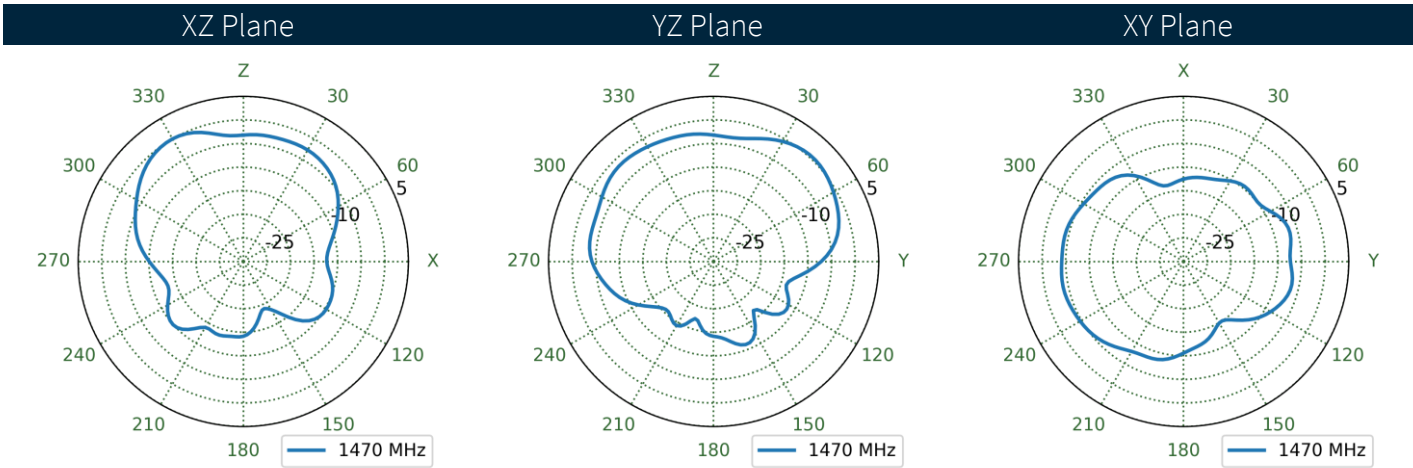
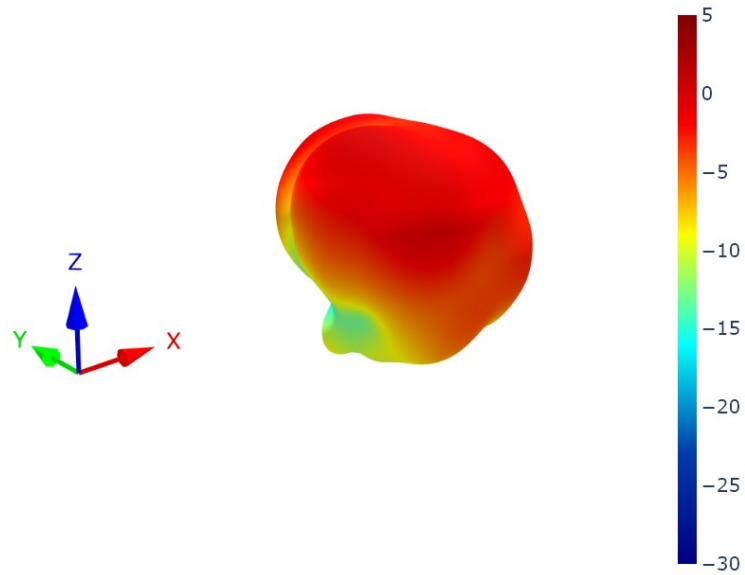

8.36 4G-5G 1 Patterns at 1805 MHz

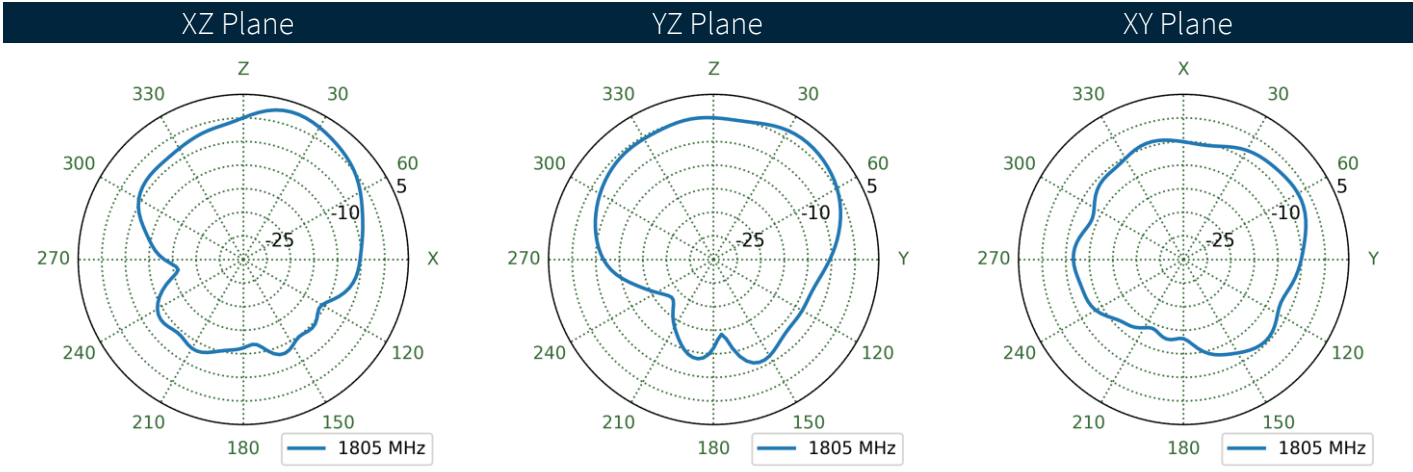
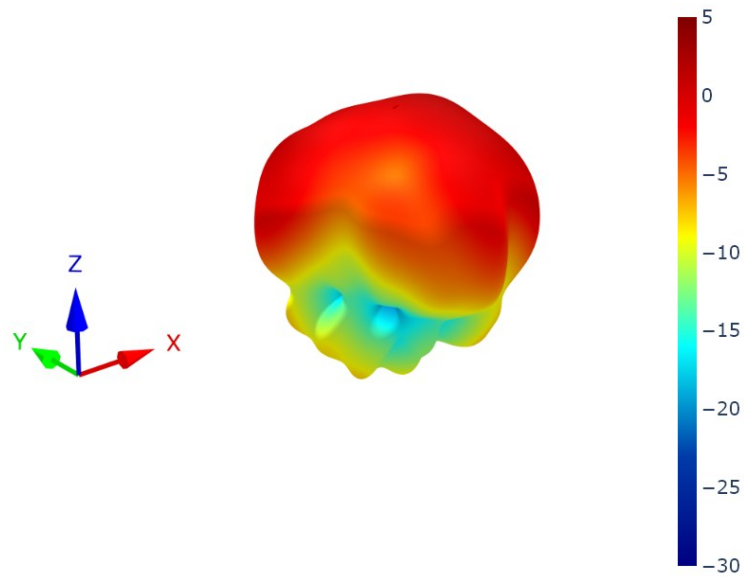

8.37 4G-5G 2 Patterns at 1805 MHz

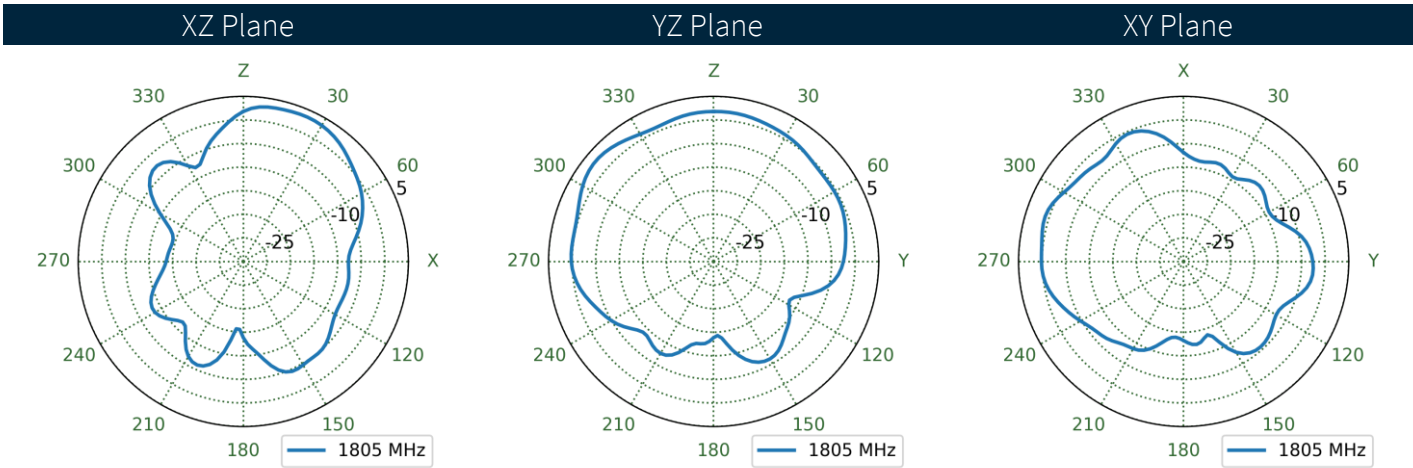
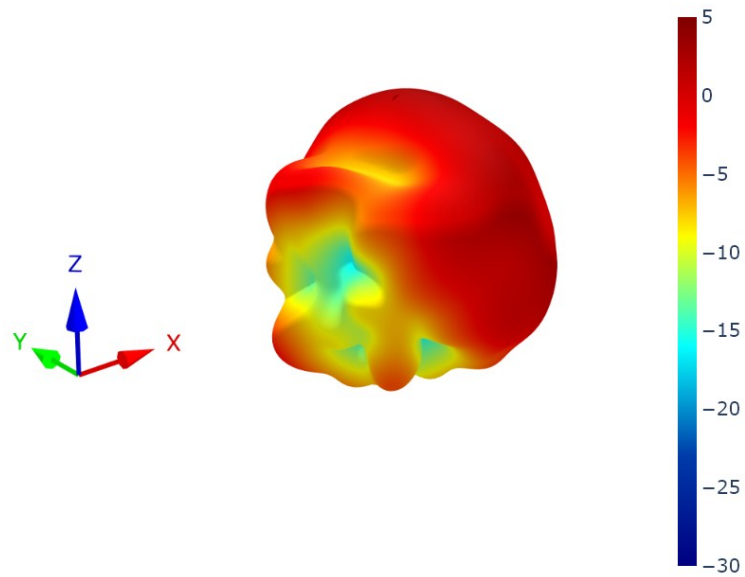

8.38 4G-5G 3 Patterns at 1805 MHz

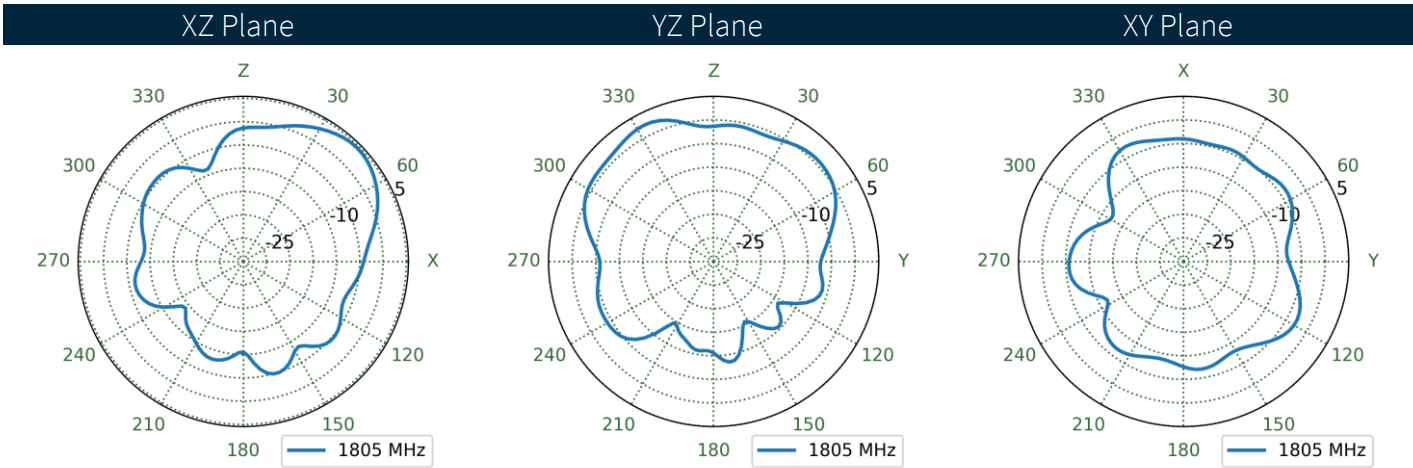
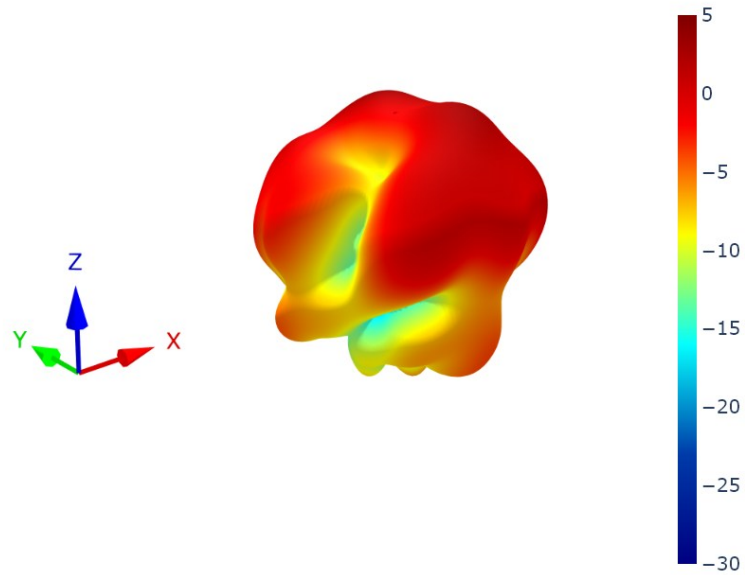

8.39 4G-5G 4 Patterns at 1805 MHz

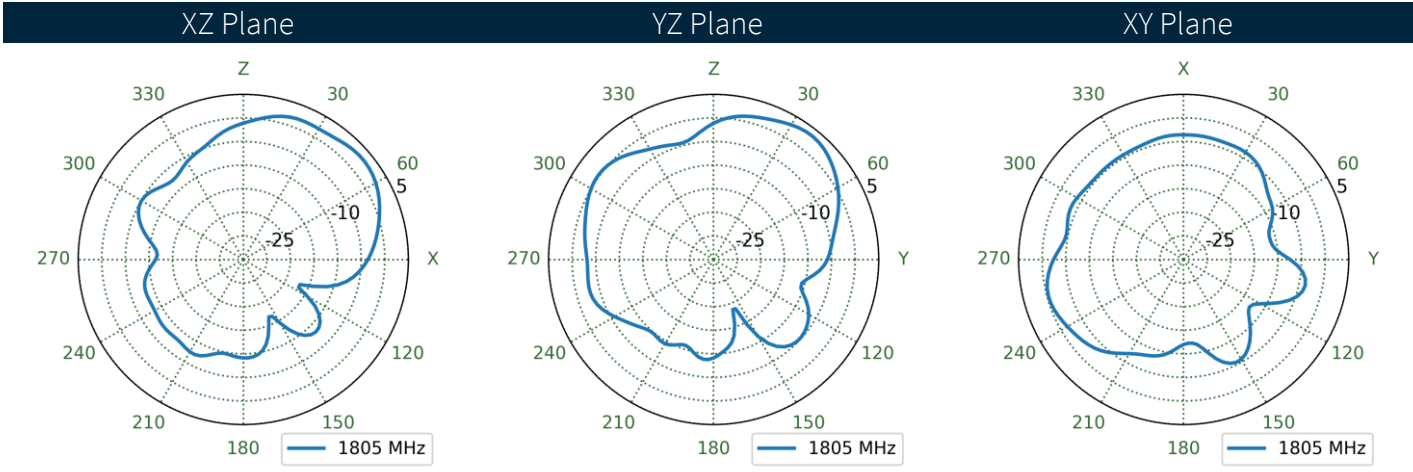
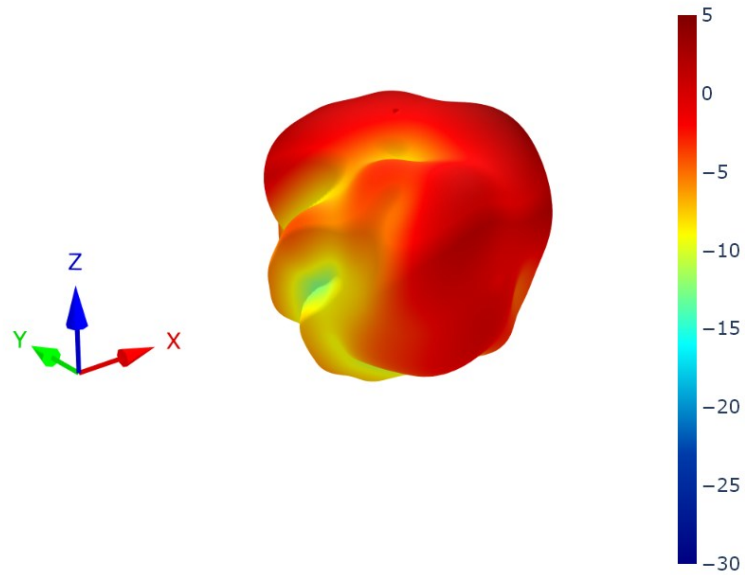

8.40 4G-5G 5 Patterns at 1805 MHz

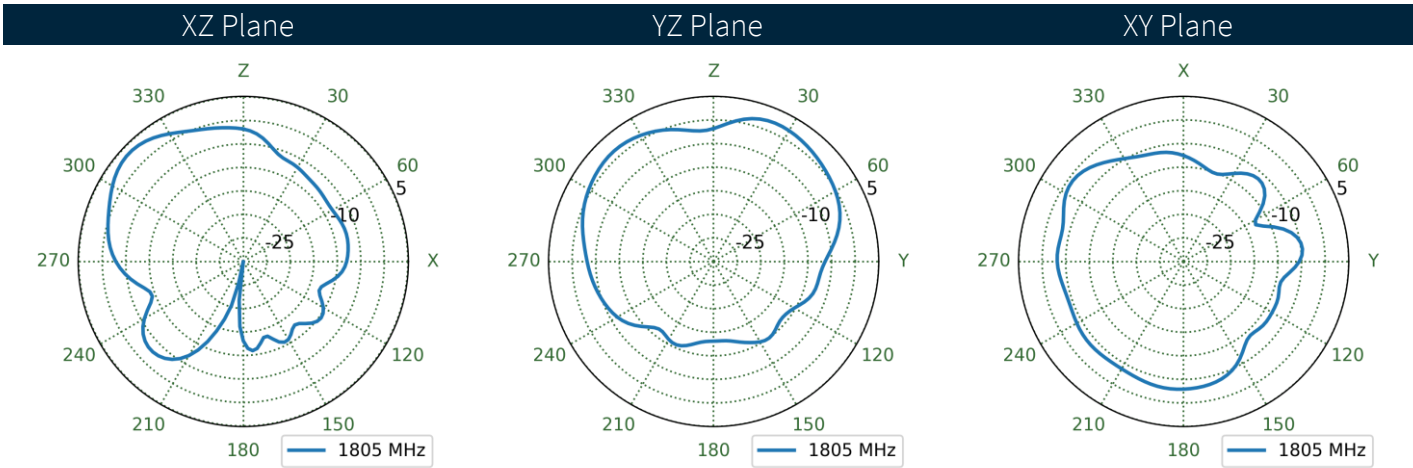
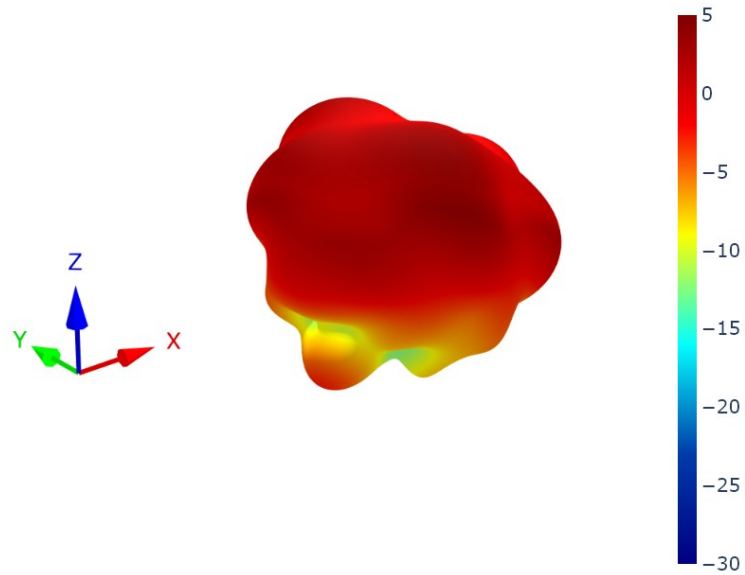

8.41 4G-5G 6 Patterns at 1805 MHz

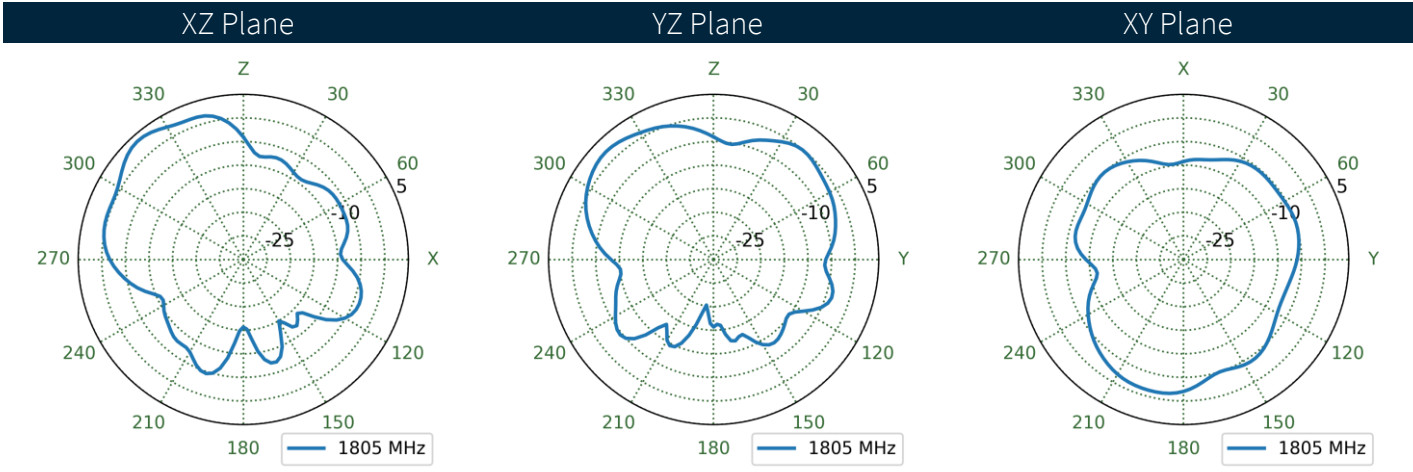
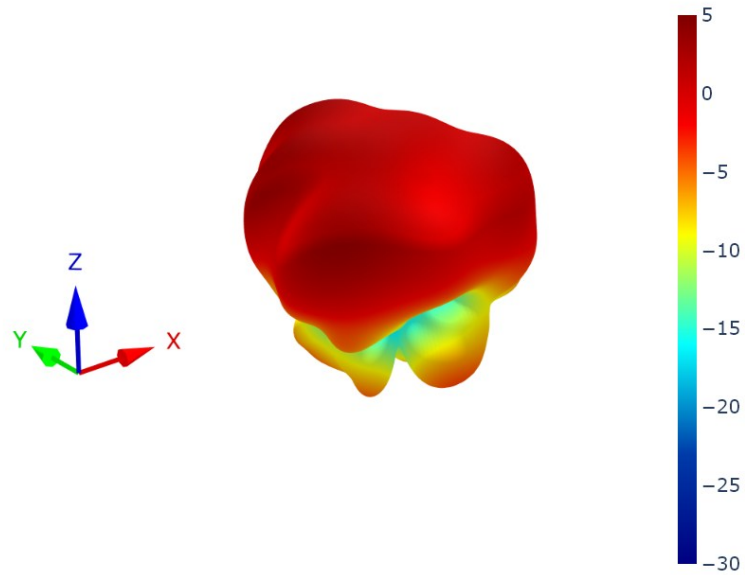

8.42 4G-5G 7 Patterns at 1805 MHz

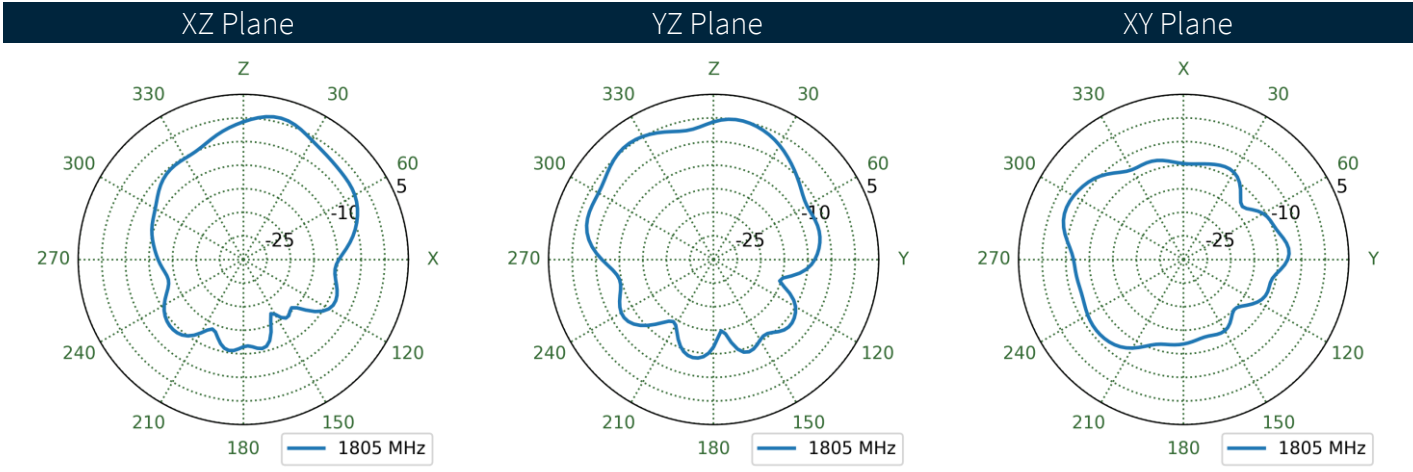
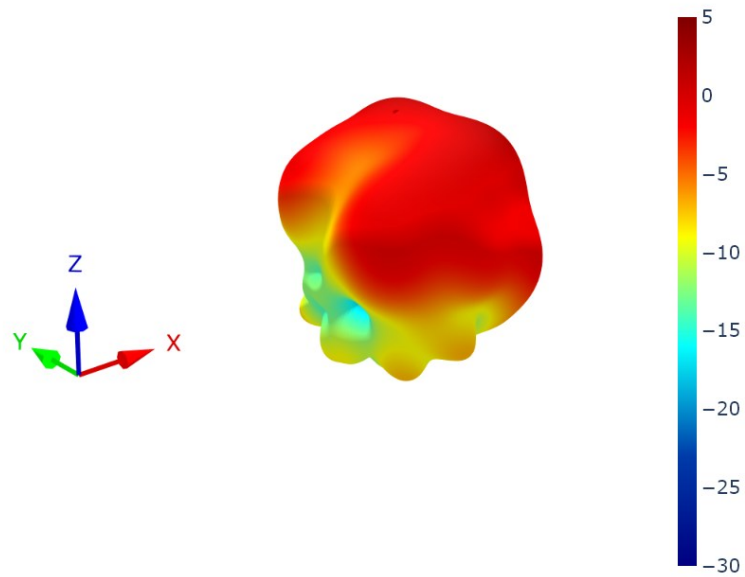

8.43 4G-5G 8 Patterns at 1805 MHz

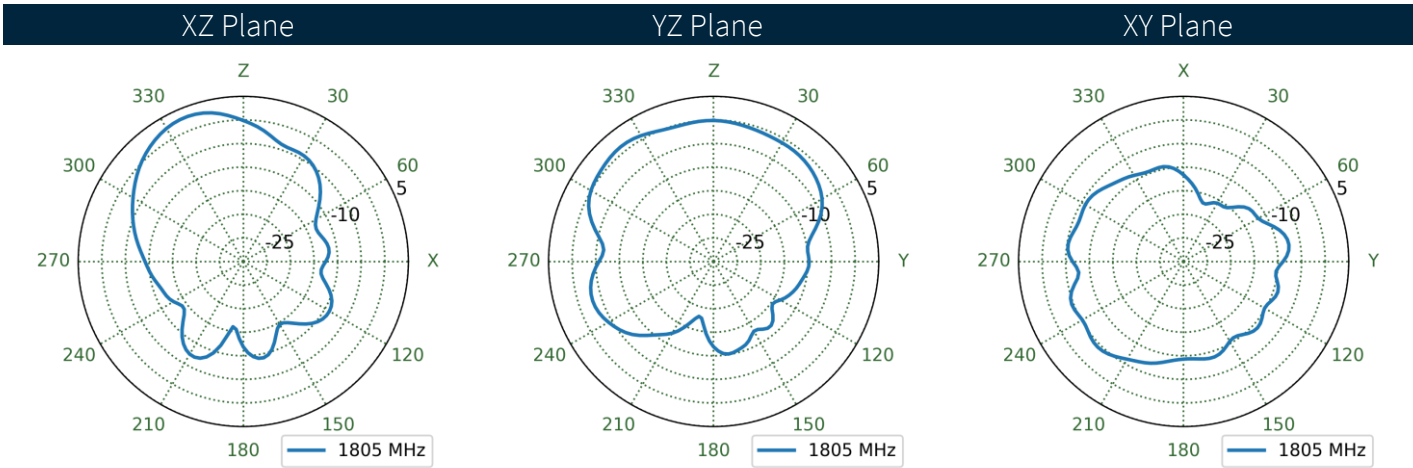
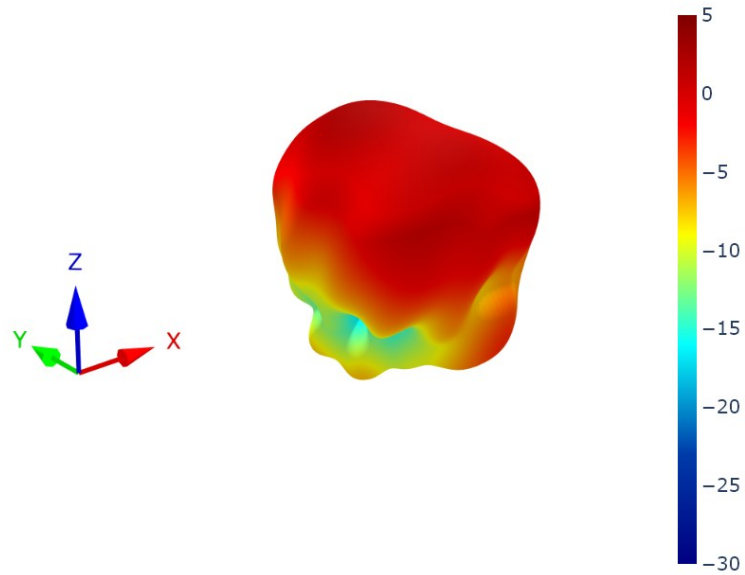

8.44 4G-5G 1 Patterns at 1920 MHz

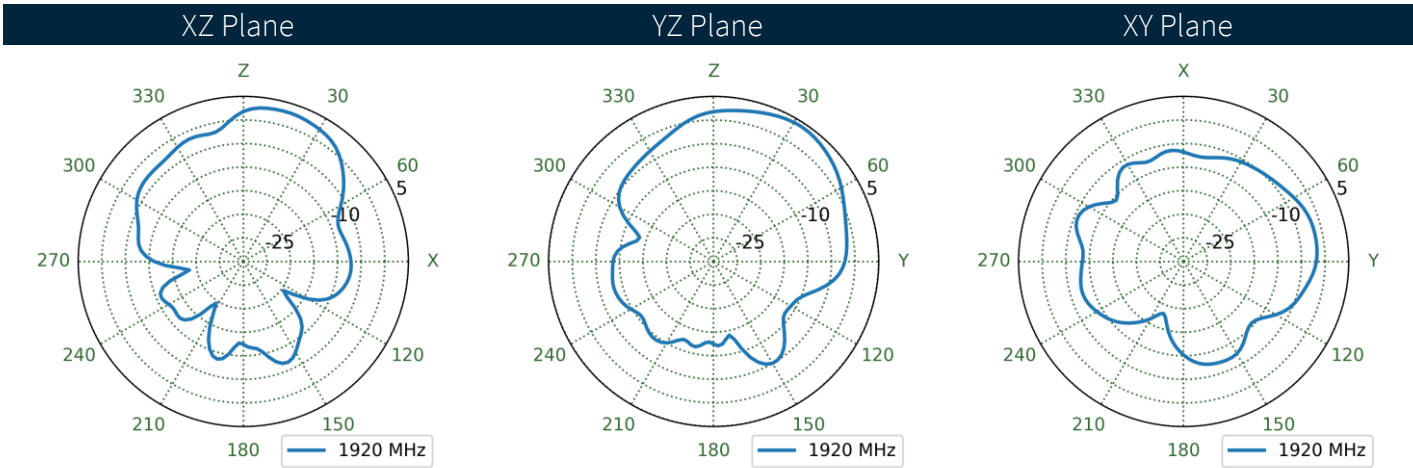
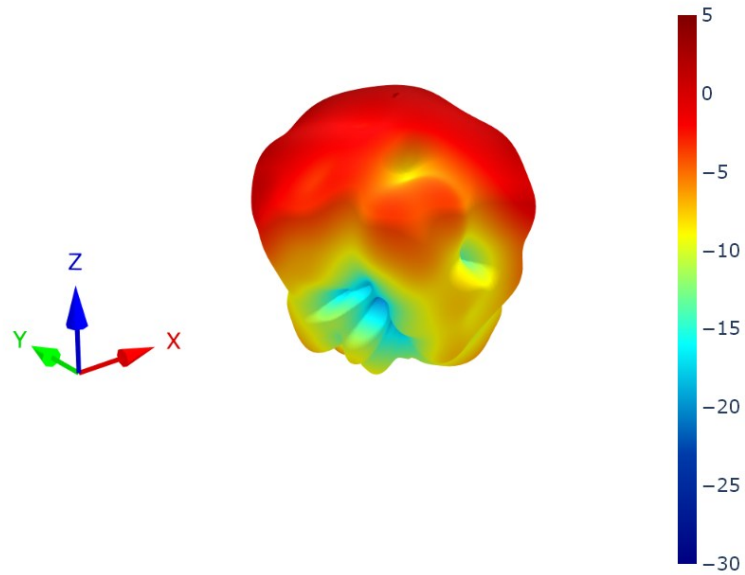

8.45 4G-5G 2 Patterns at 1920 MHz

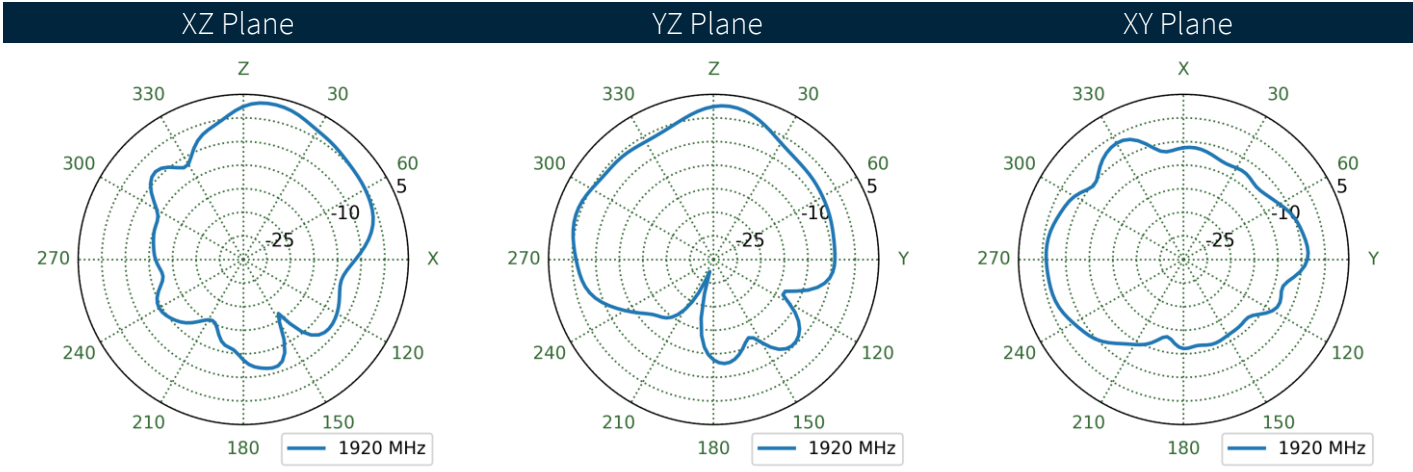
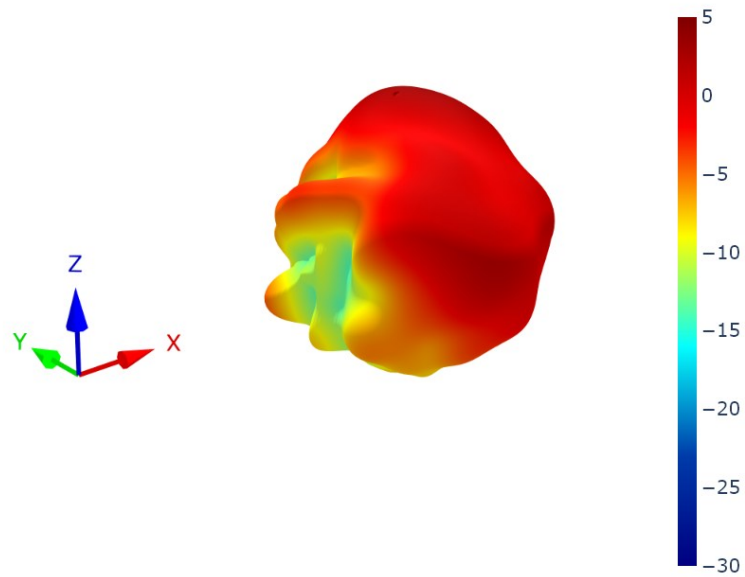

8.46 4G-5G 3 Patterns at 1920 MHz

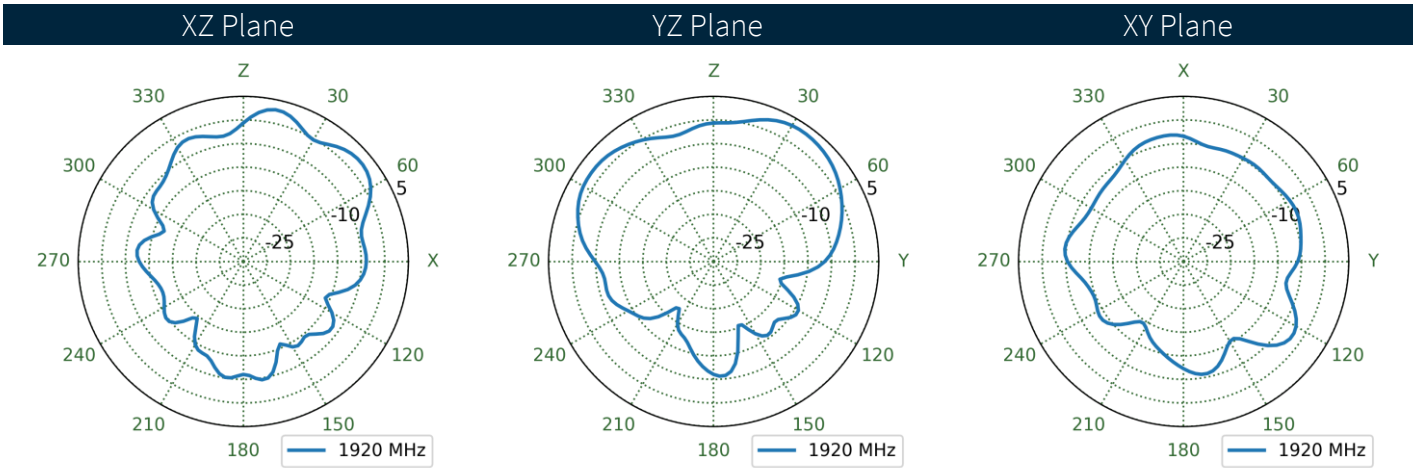
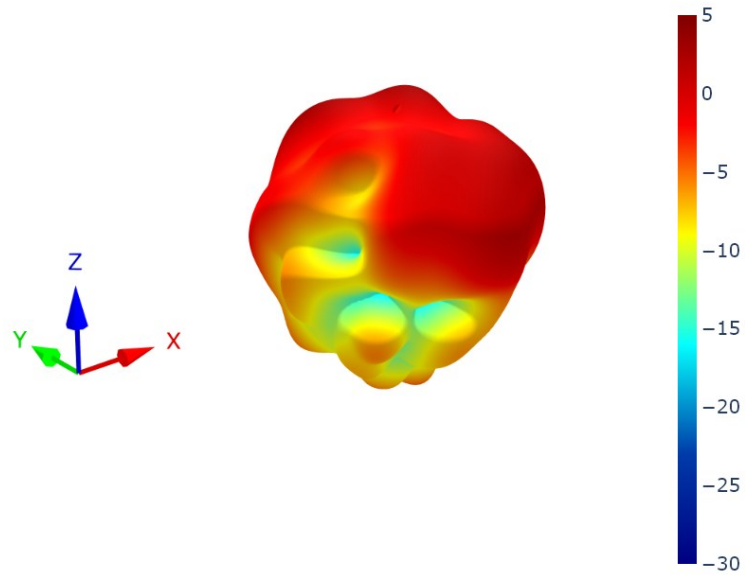

8.47 4G-5G 4 Patterns at 1920 MHz

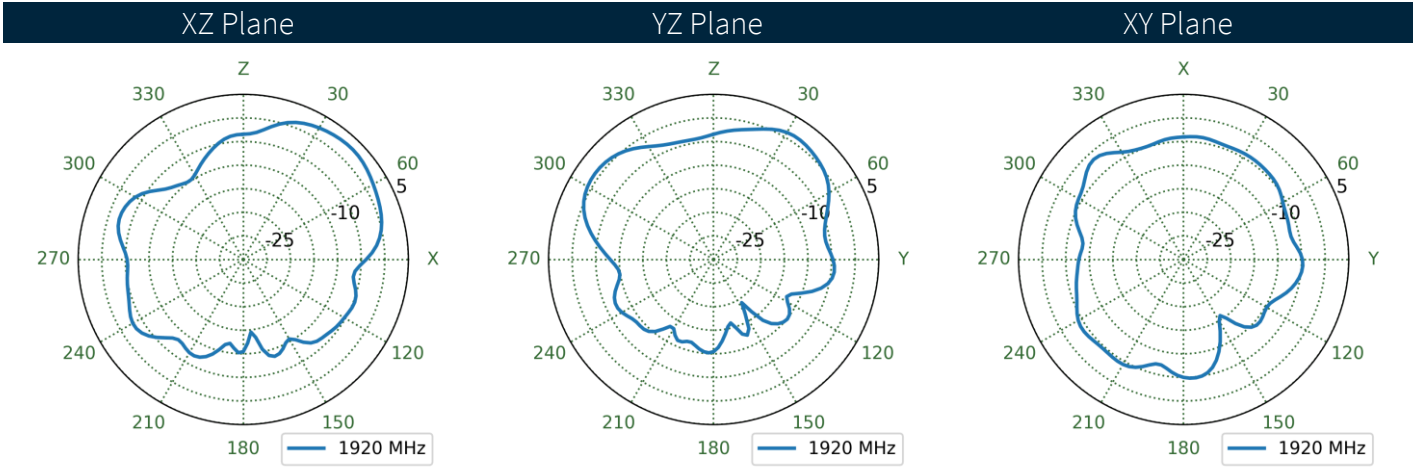
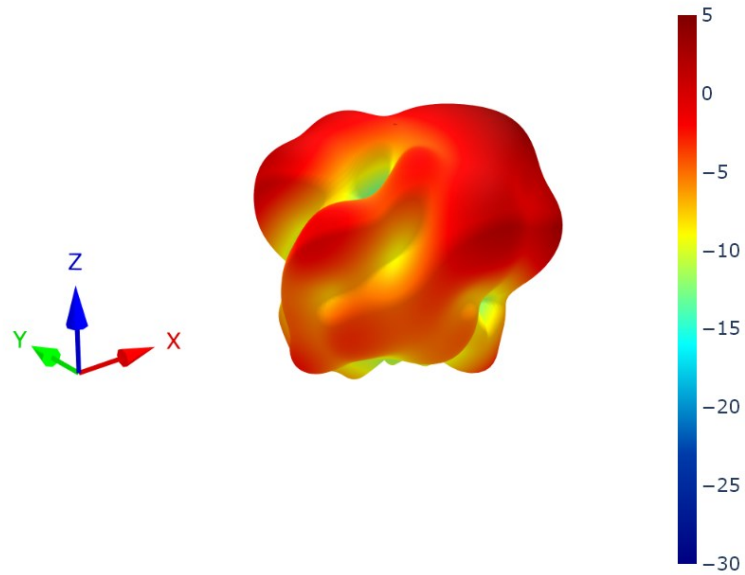

8.48 4G-5G 5 Patterns at 1920 MHz

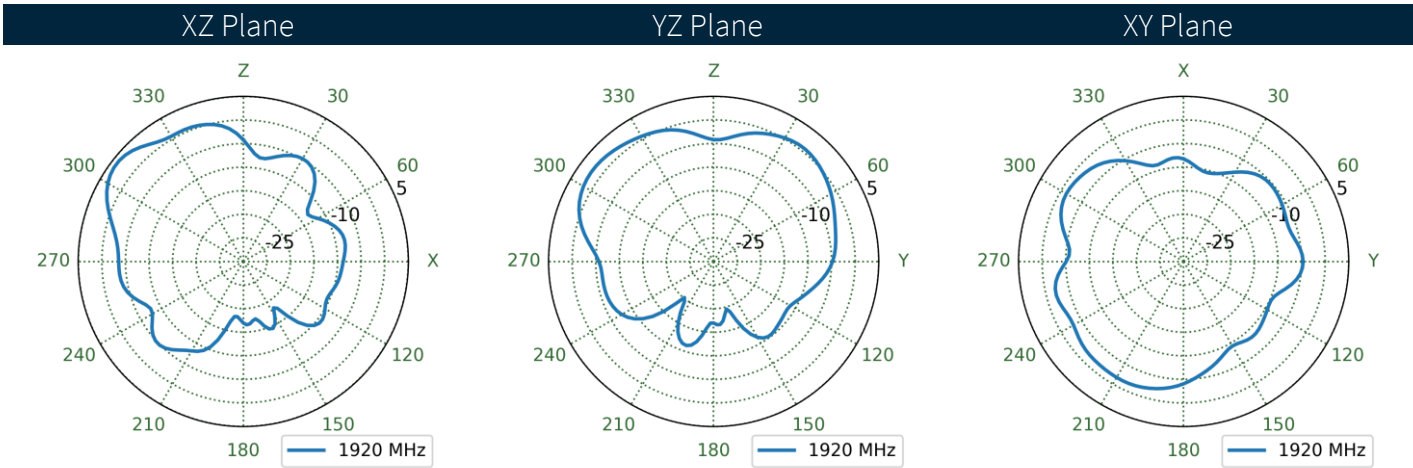
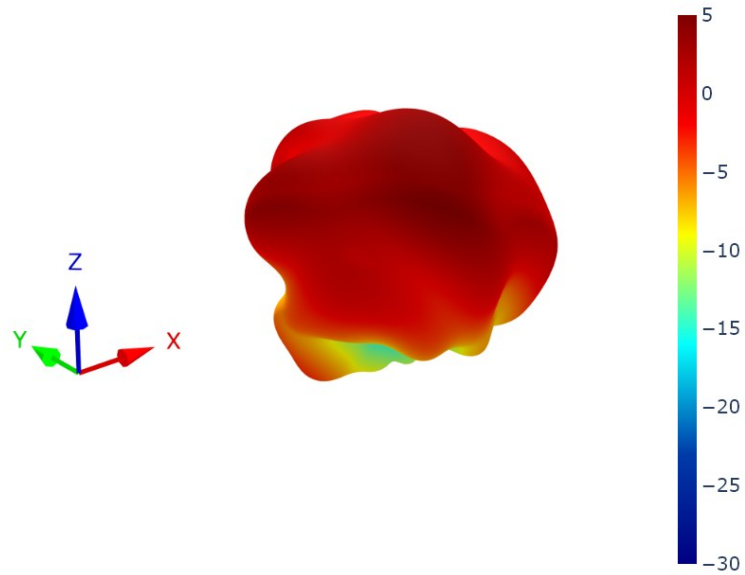

8.49 4G-5G 6 Patterns at 1920 MHz

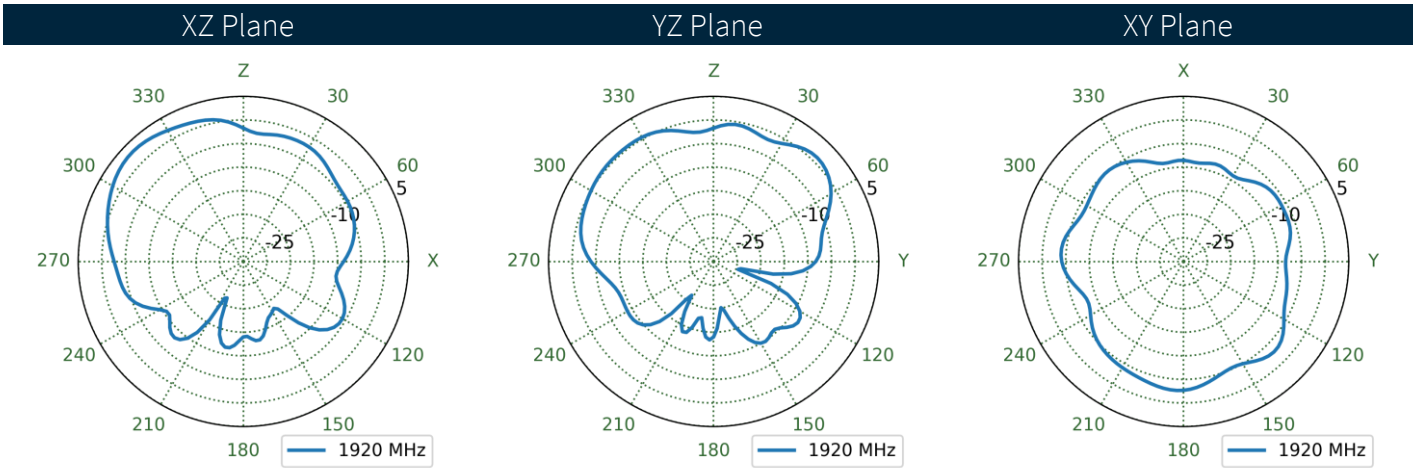
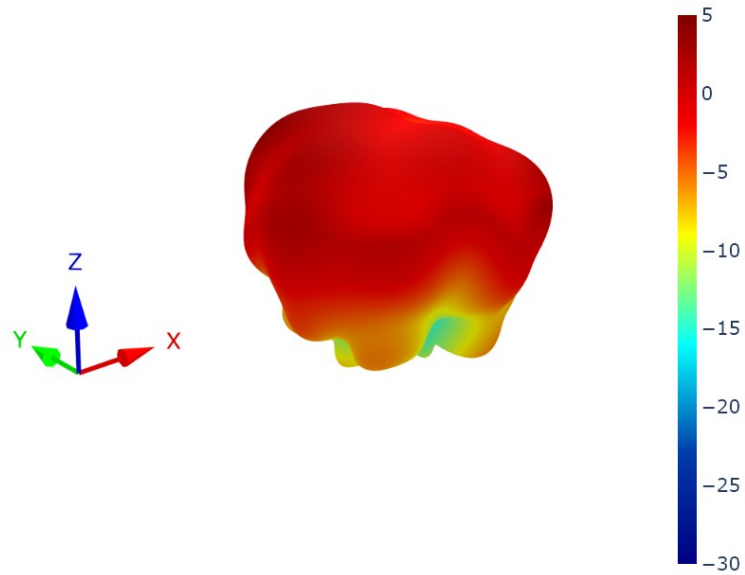

8.50 4G-5G 7 Patterns at 1920 MHz

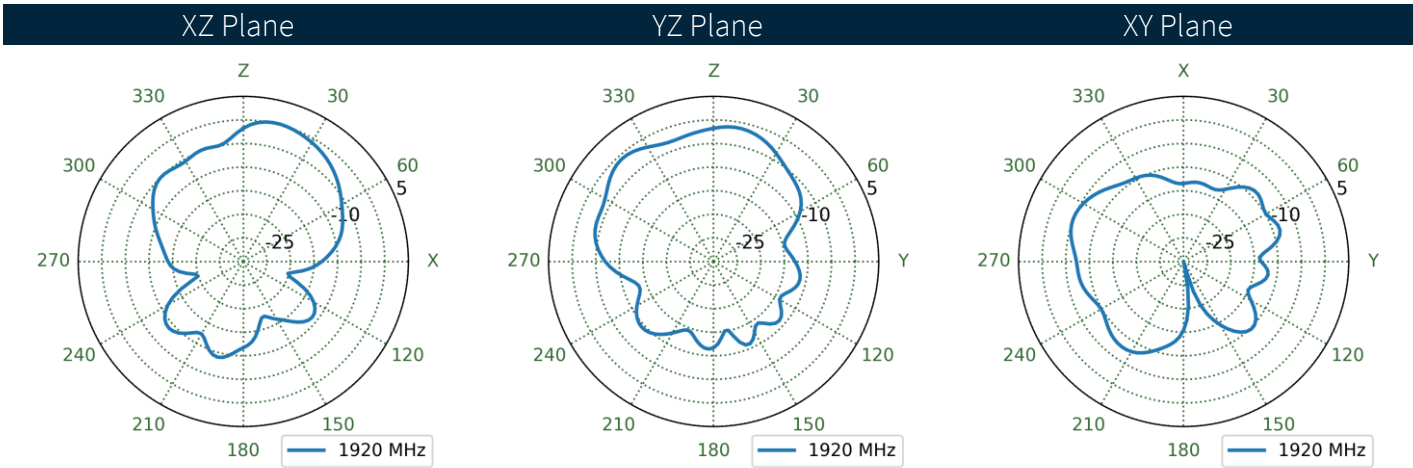
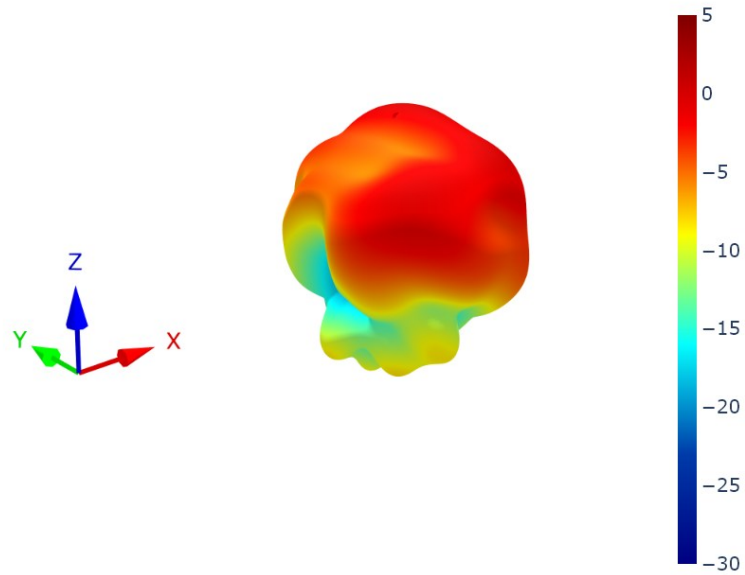

8.51 4G-5G 8 Patterns at 1920 MHz

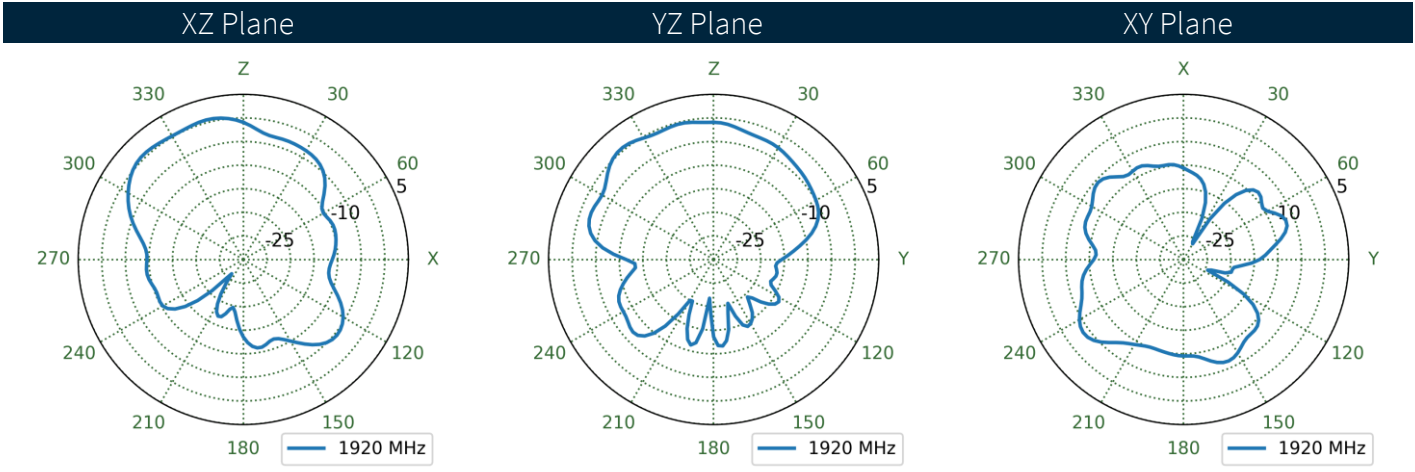
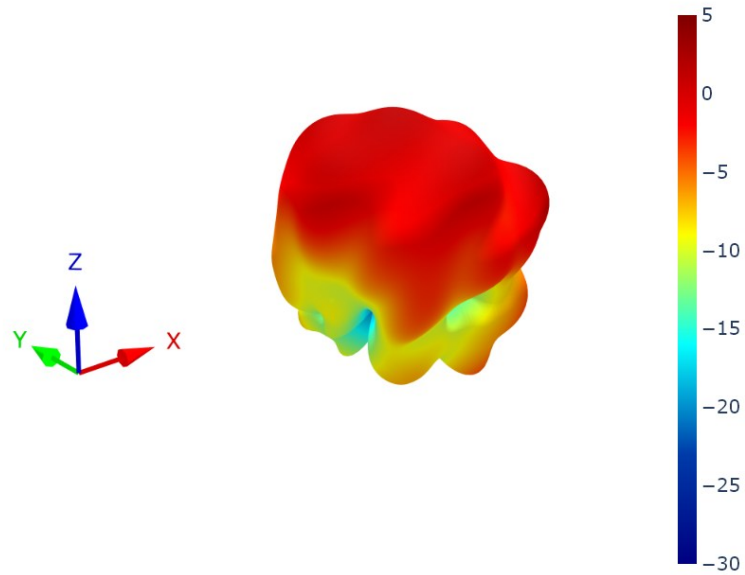

8.52 4G-5G 1 Patterns at 1990 MHz

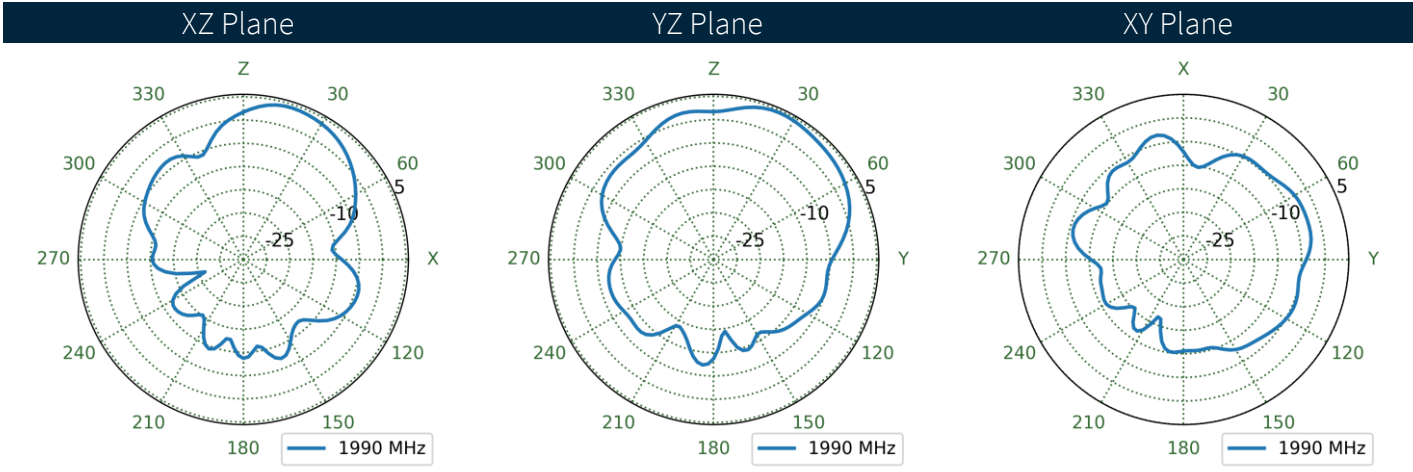
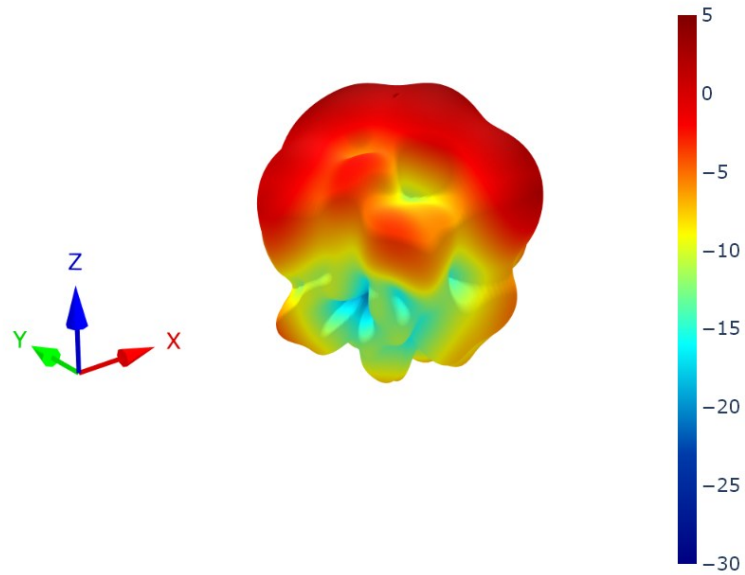

8.53 4G-5G 2 Patterns at 1990 MHz

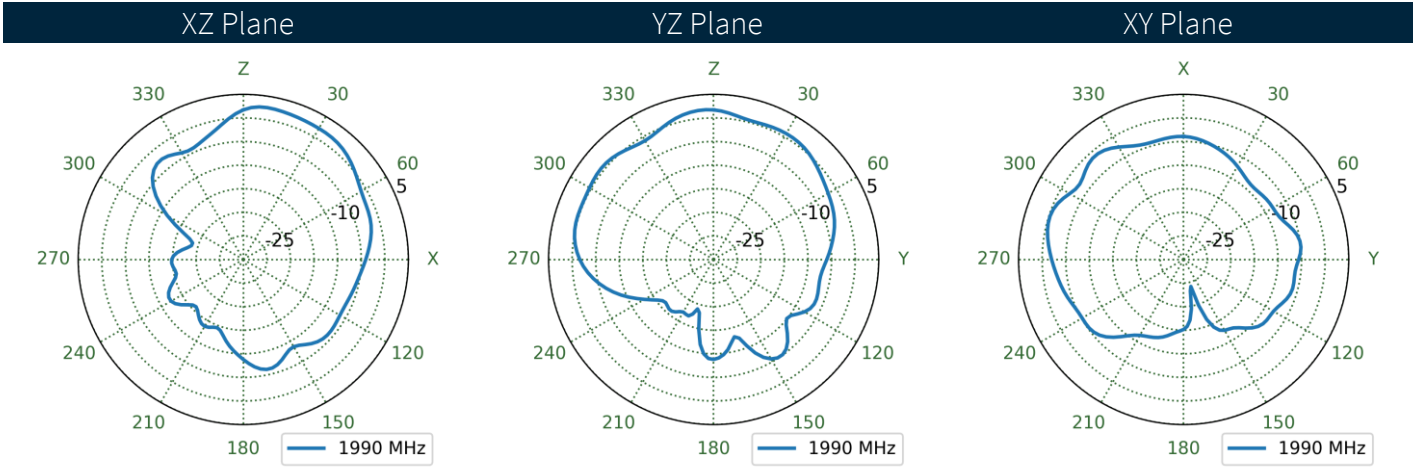
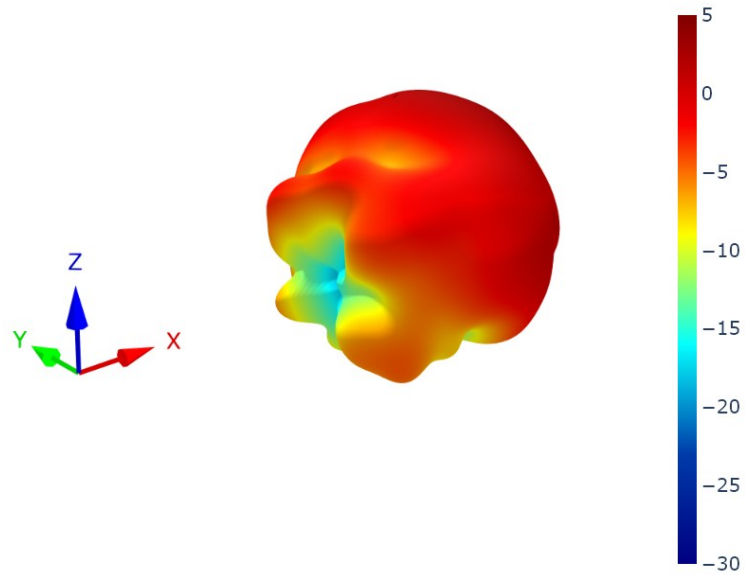

8.54 4G-5G 3 Patterns at 1990 MHz

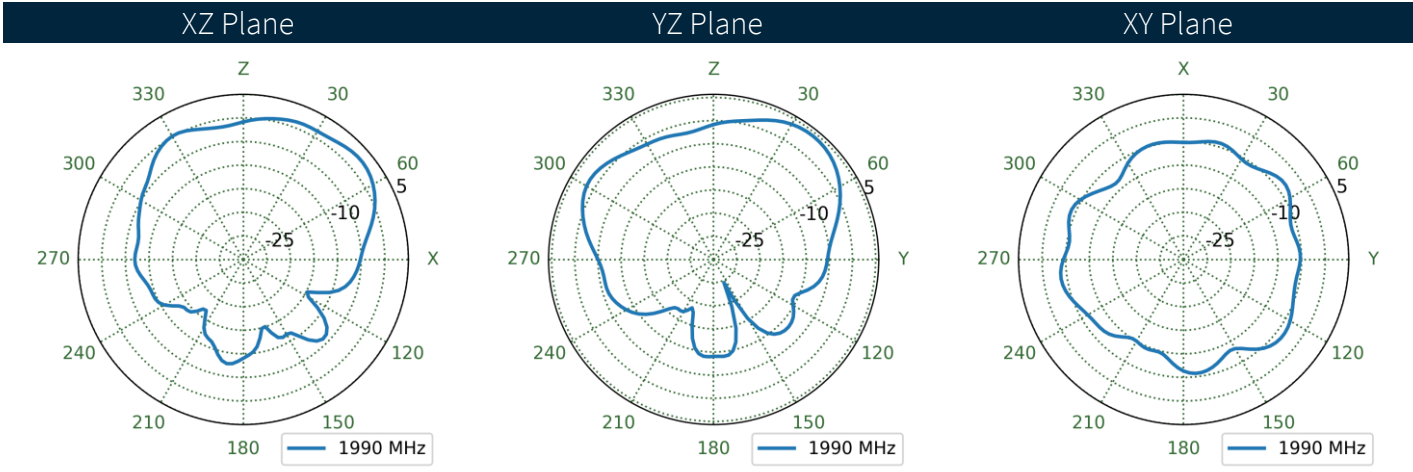
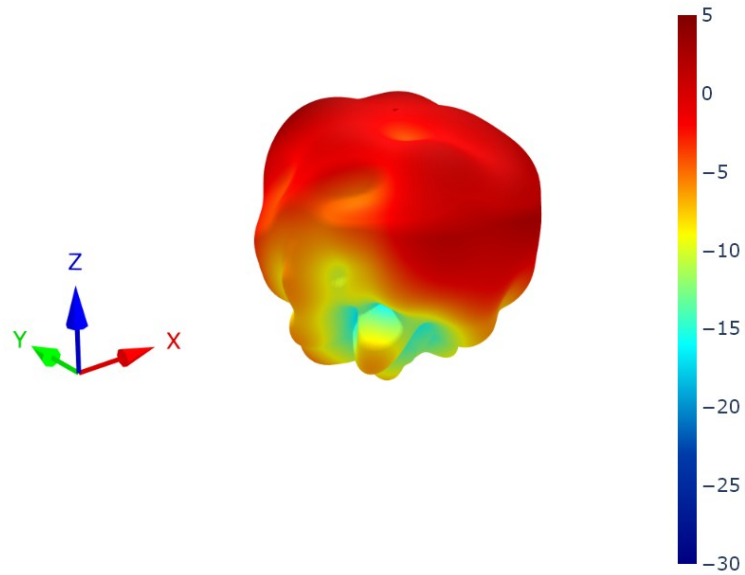

8.55 4G-5G 4 Patterns at 1990 MHz

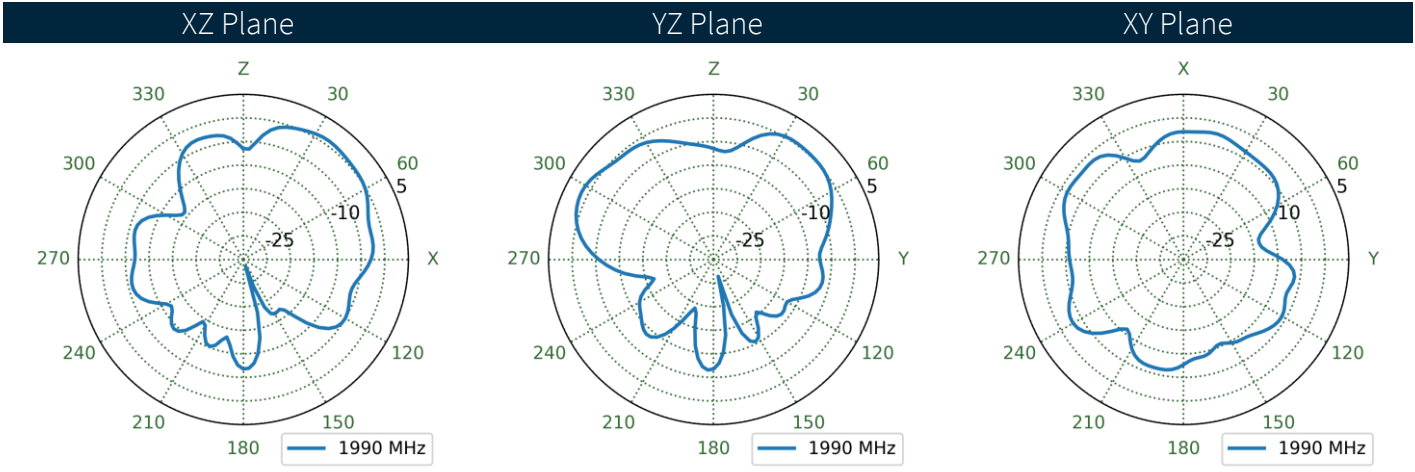
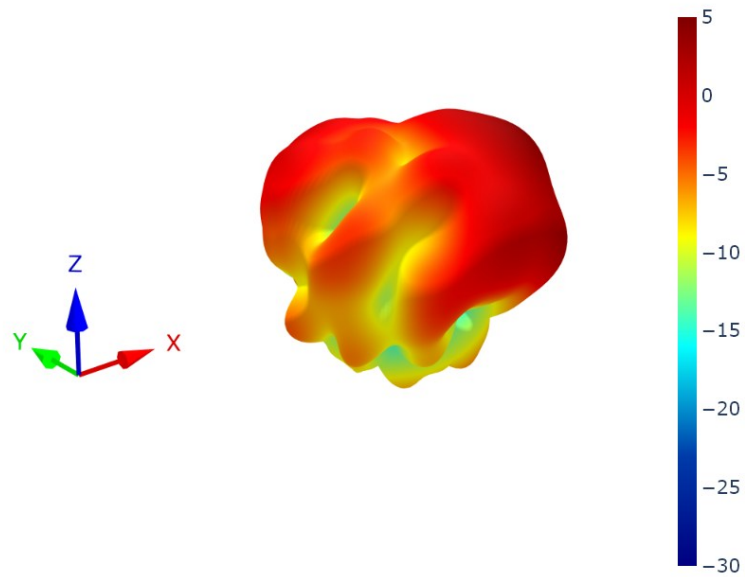

8.56 4G-5G 5 Patterns at 1990 MHz

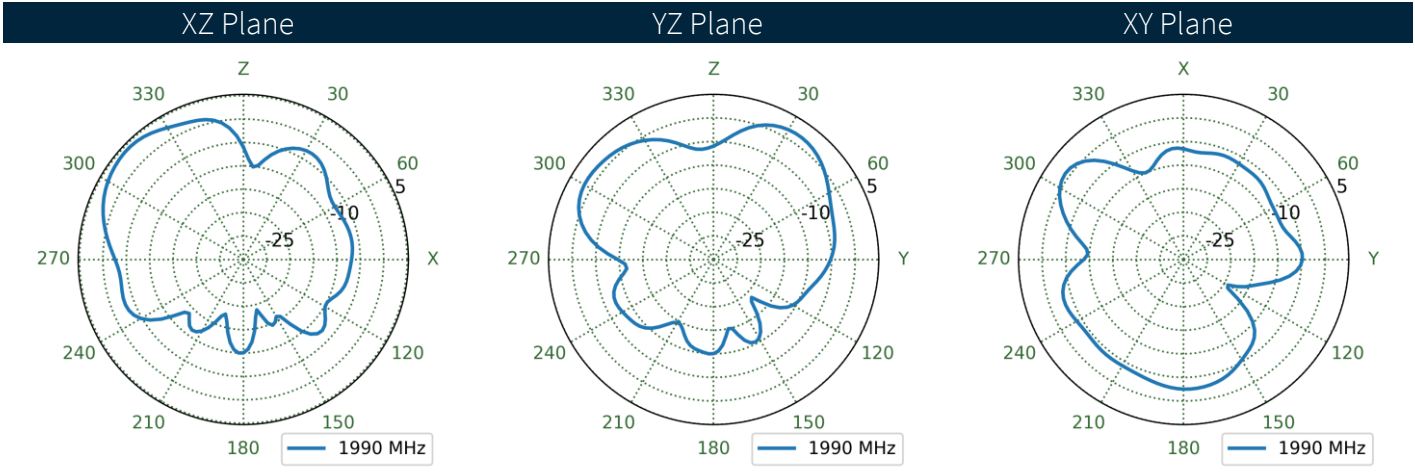
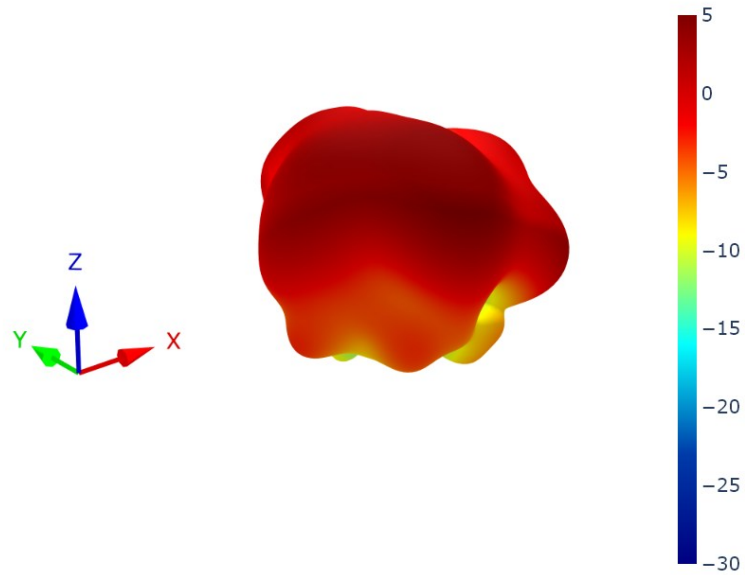

8.57 4G-5G 6 Patterns at 1990 MHz

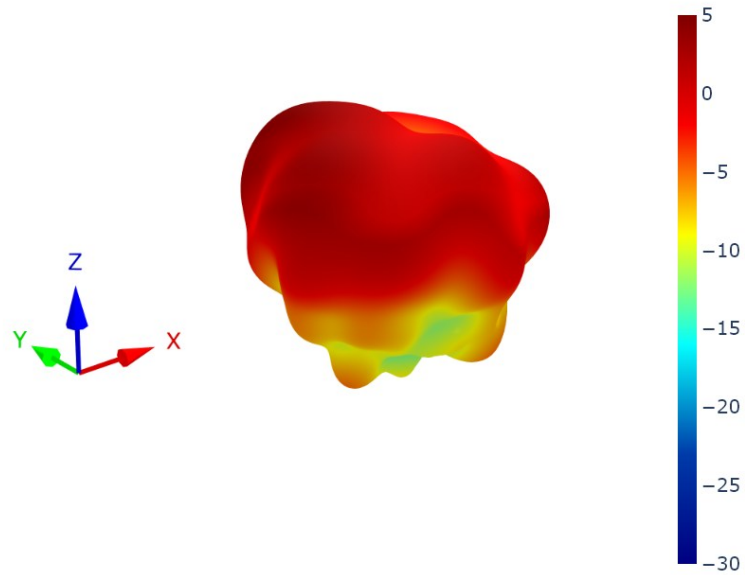

XZ Plane YZ Plane XY Plane

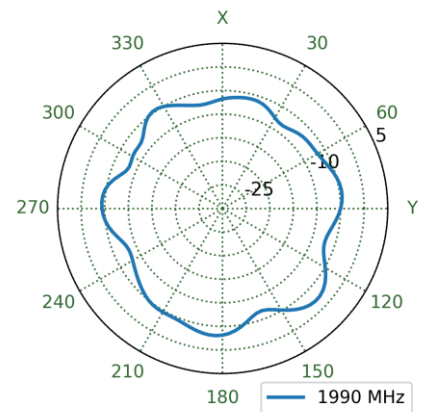
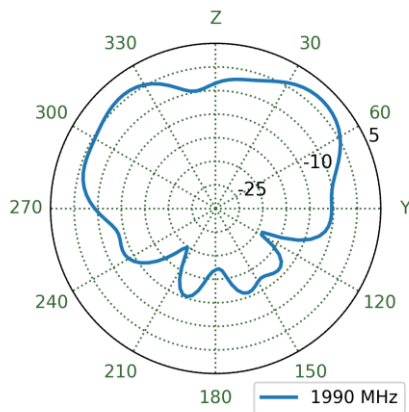
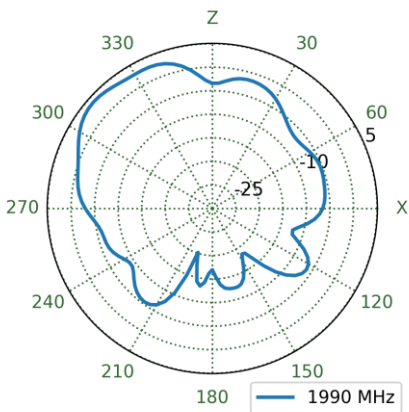

8.58 4G-5G 7 Patterns at 1990 MHz

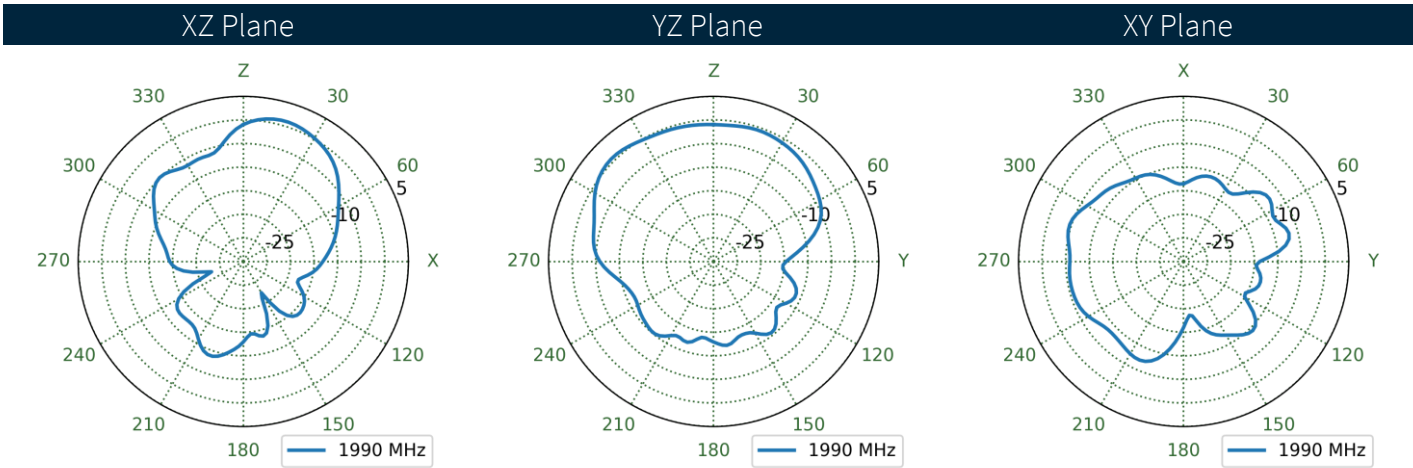
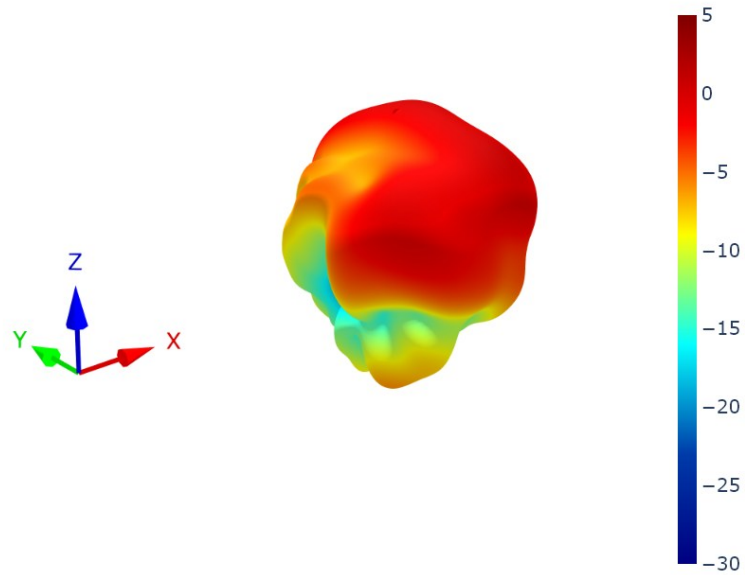

8.59 4G-5G 8 Patterns at 1990 MHz

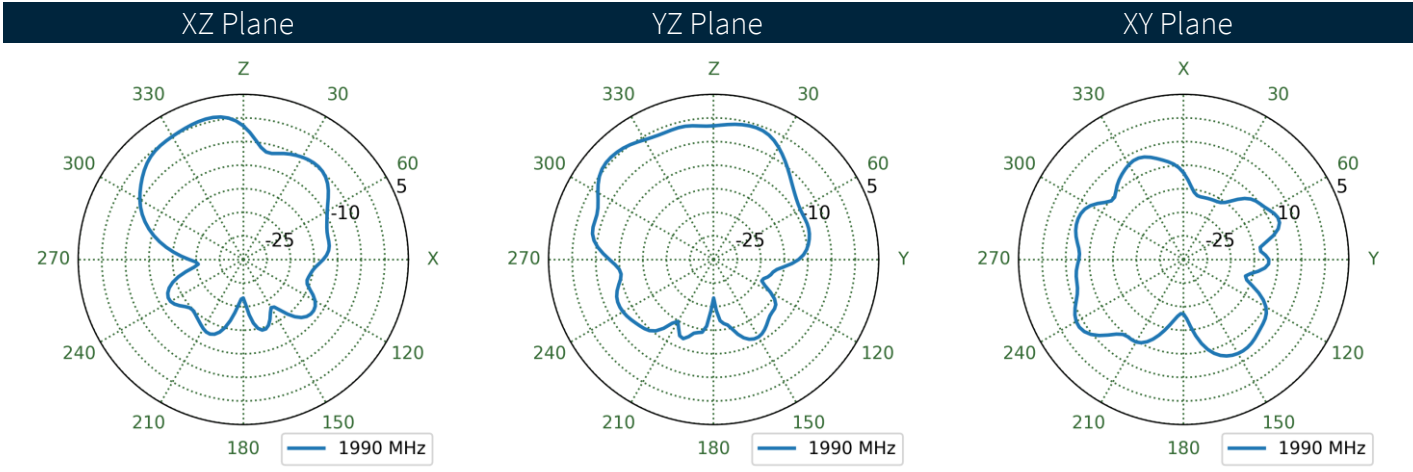
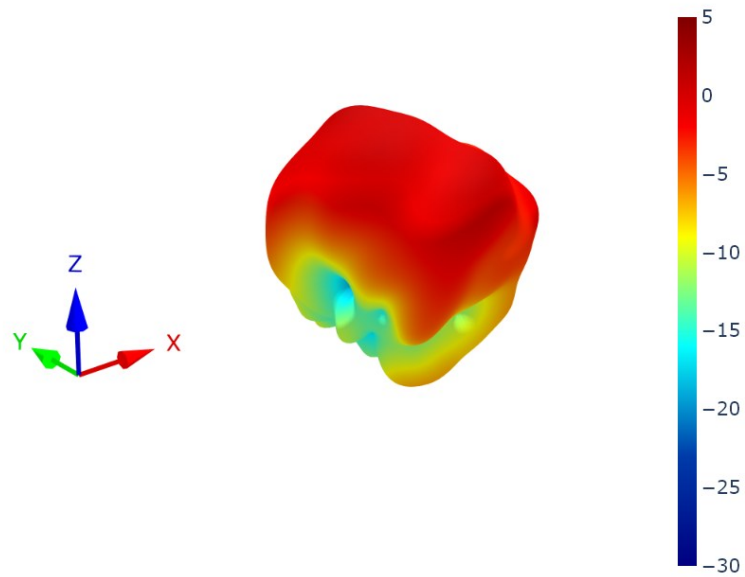

8.60 4G-5G 1 Patterns at 2360 MHz

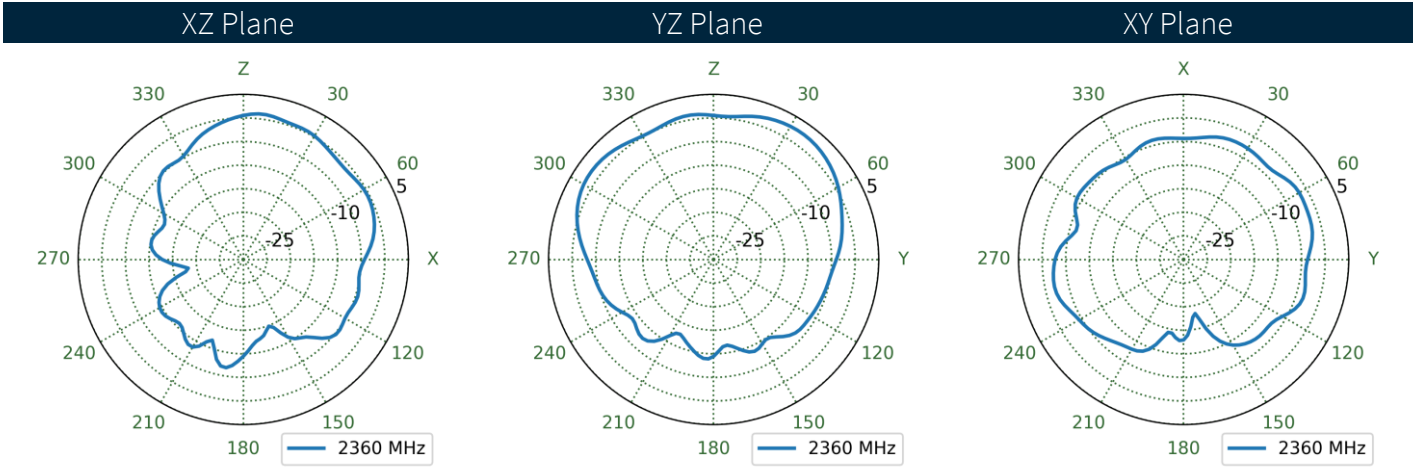
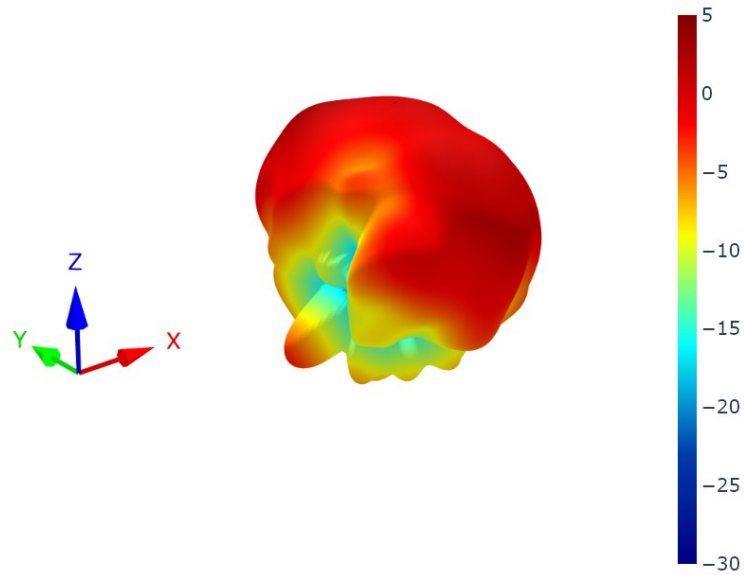

8.61 4G-5G 2 Patterns at 2360 MHz

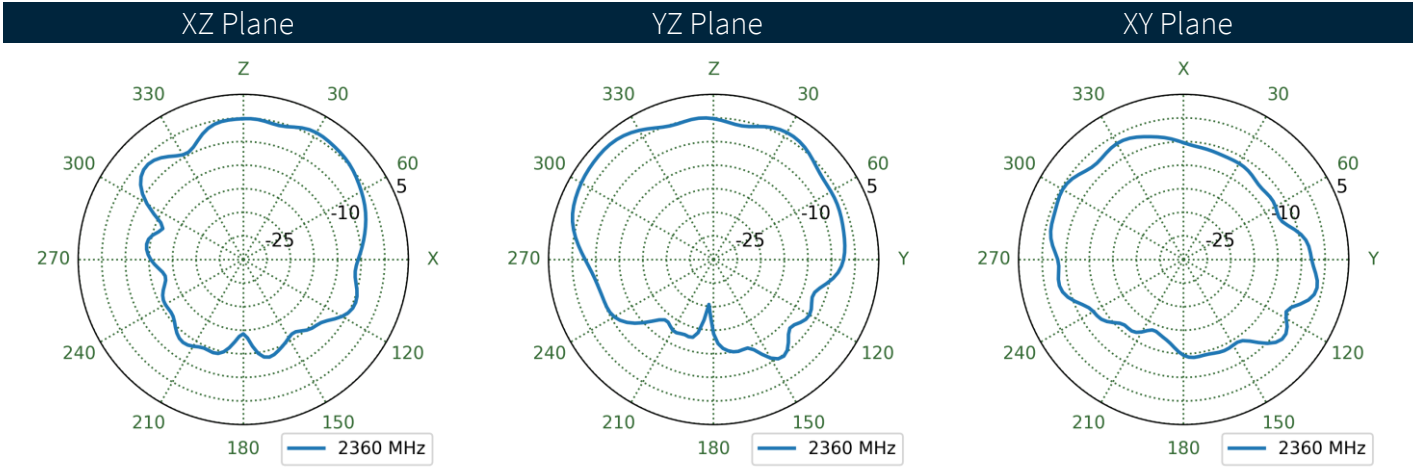
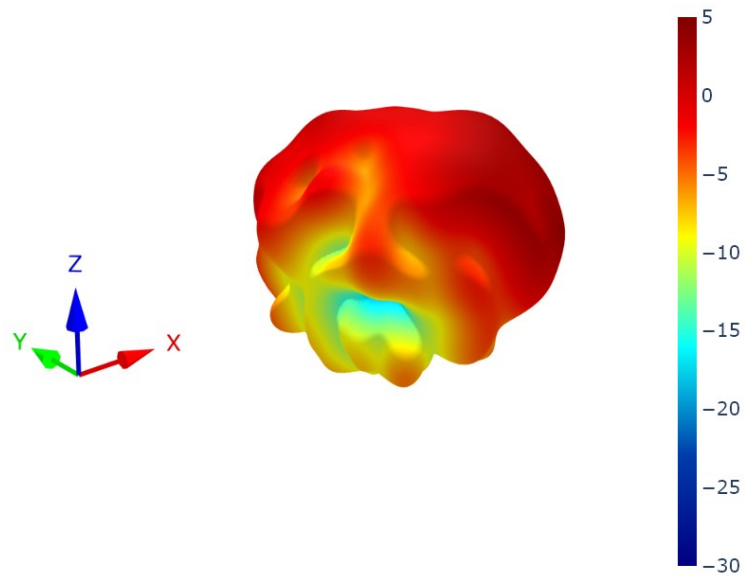

8.62 4G-5G 3 Patterns at 2360 MHz

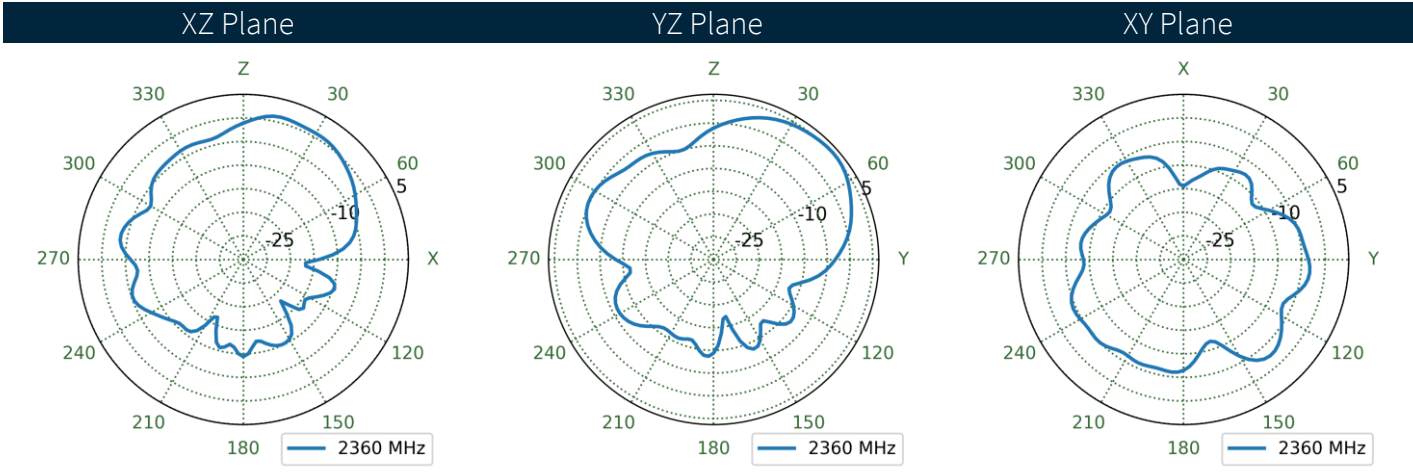
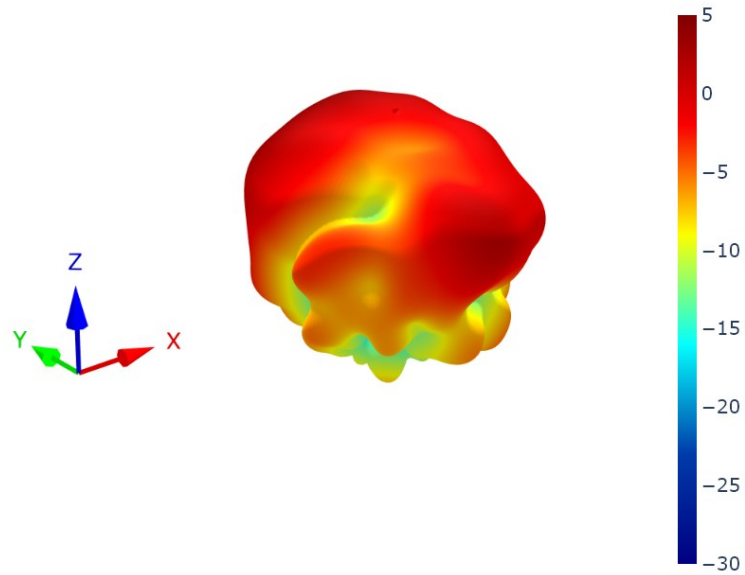

8.63 4G-5G 4 Patterns at 2360 MHz

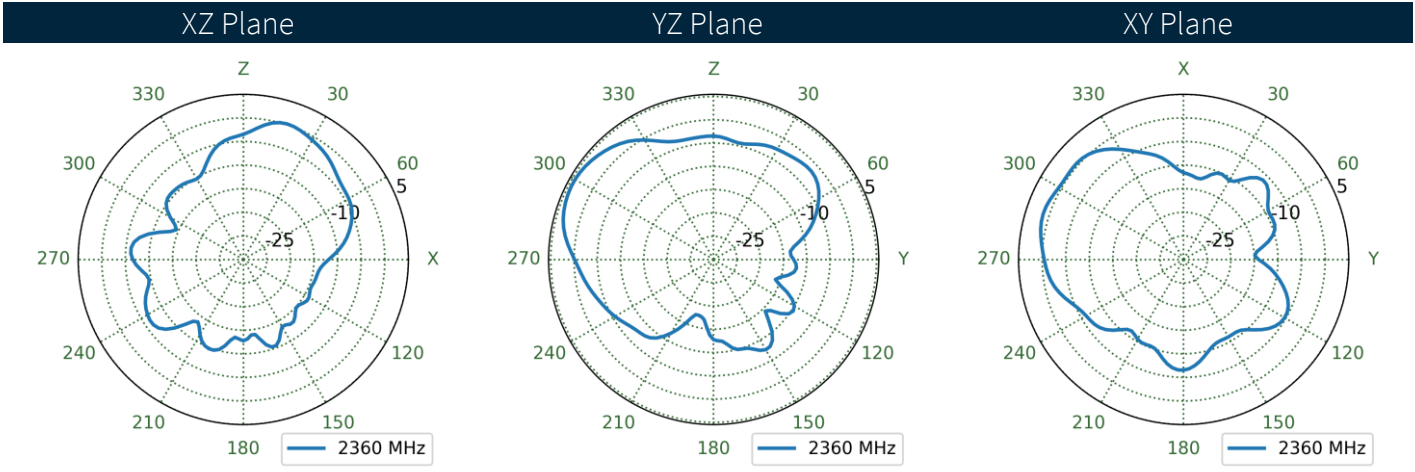
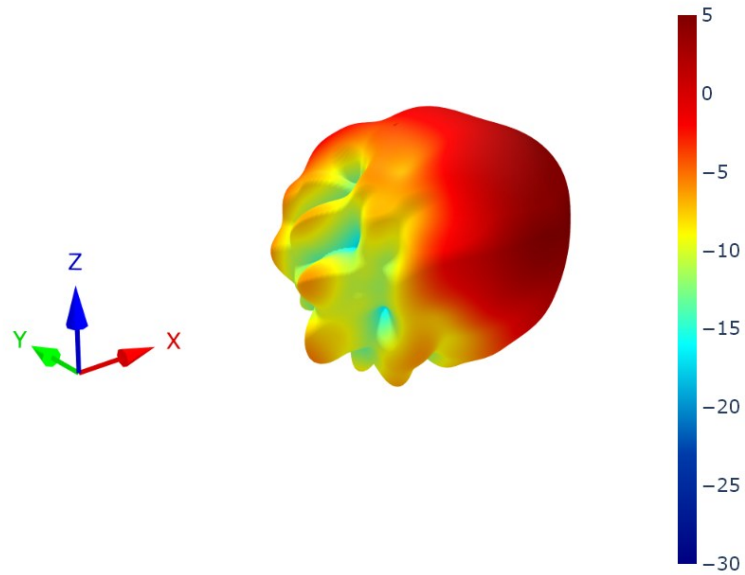

8.64 4G-5G 5 Patterns at 2360 MHz

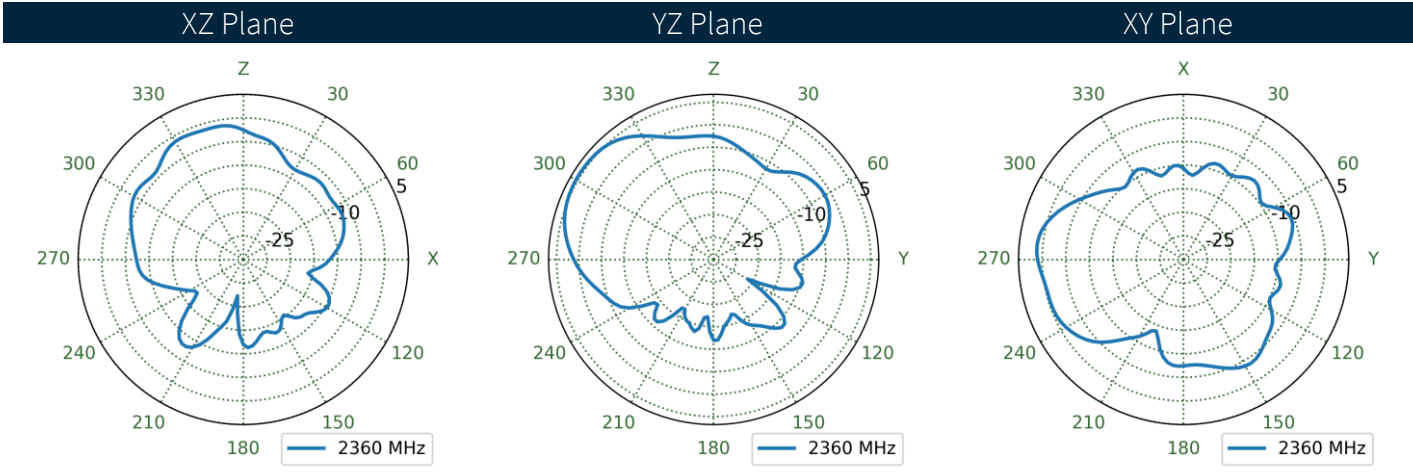
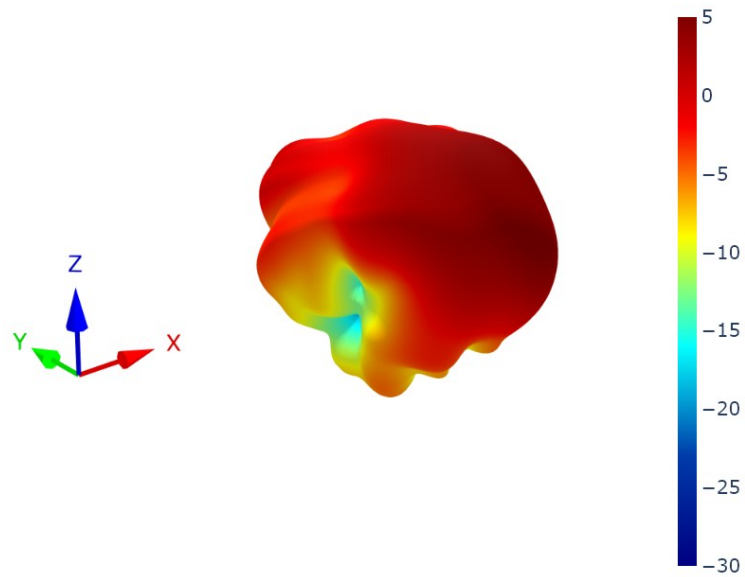

8.65 4G-5G 6 Patterns at 2360 MHz

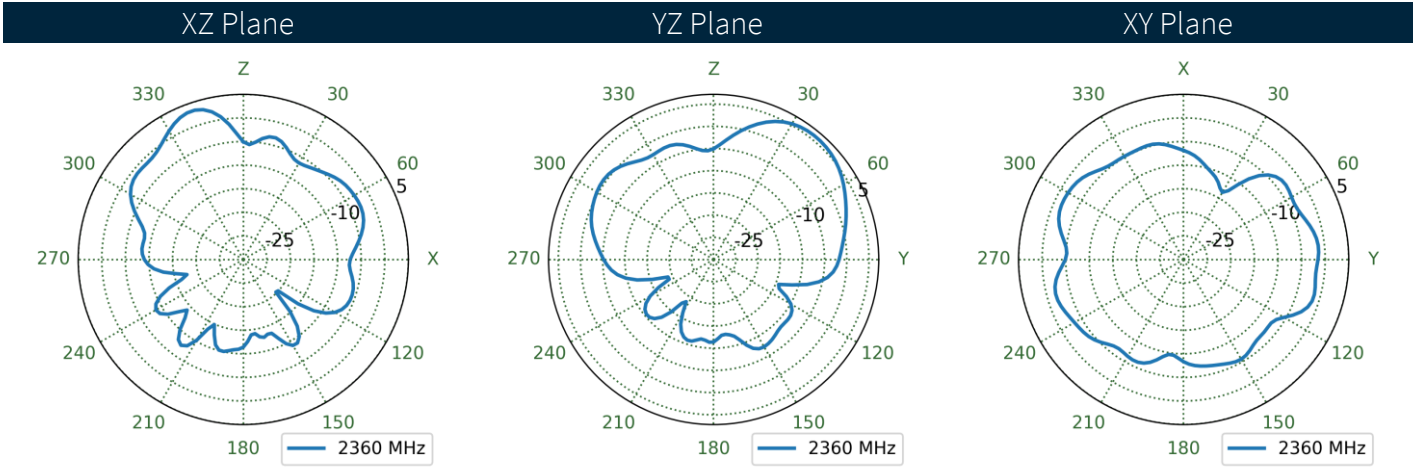
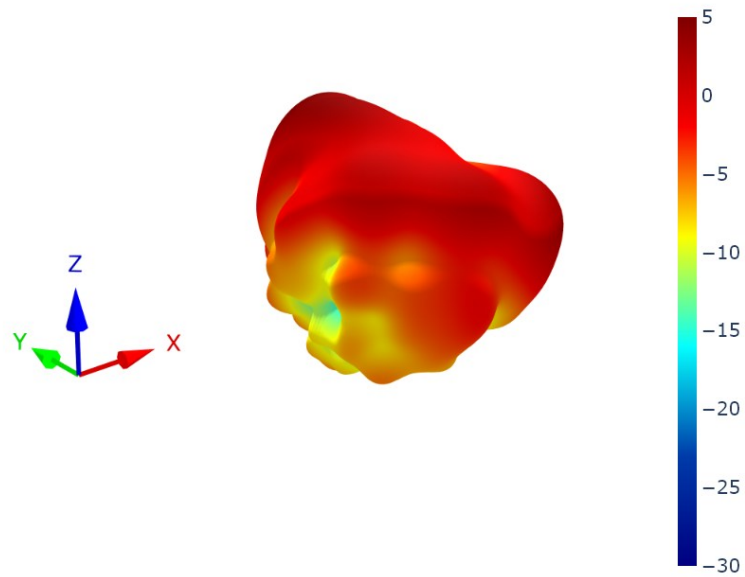

8.66 4G-5G 7 Patterns at 2360 MHz

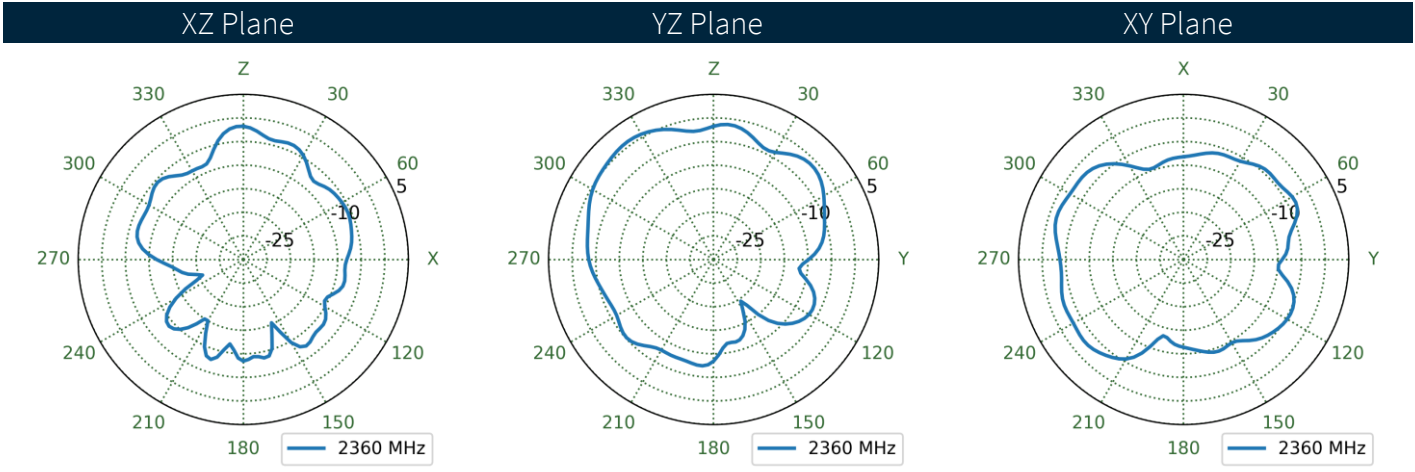
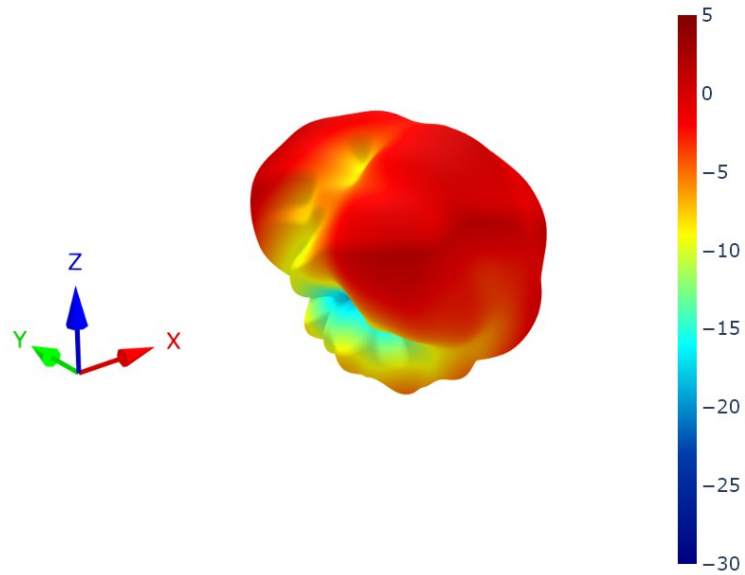

8.67 4G-5G 8 Patterns at 2360 MHz

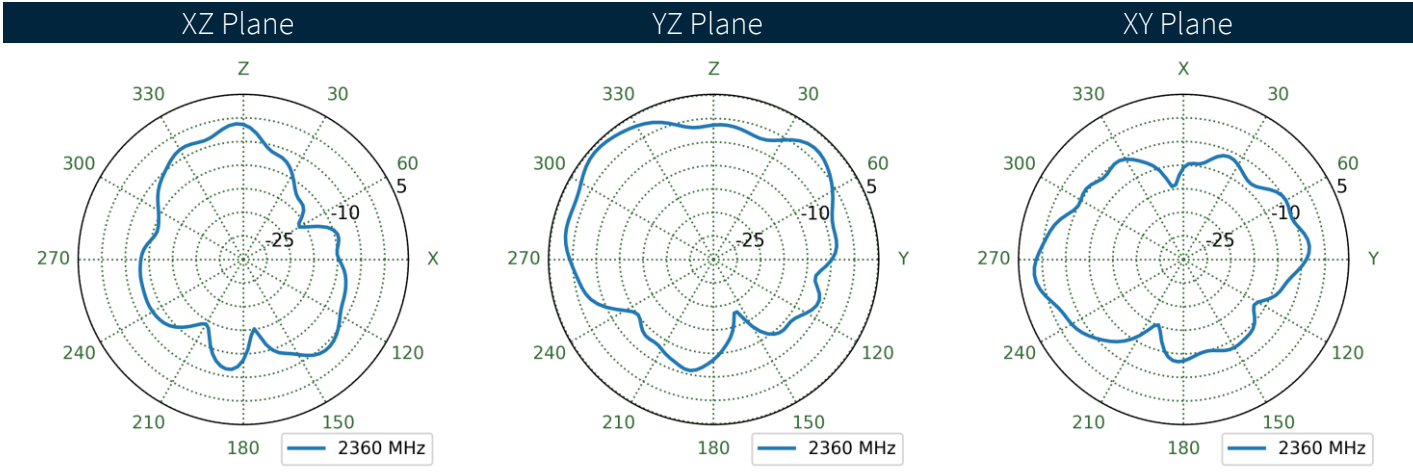
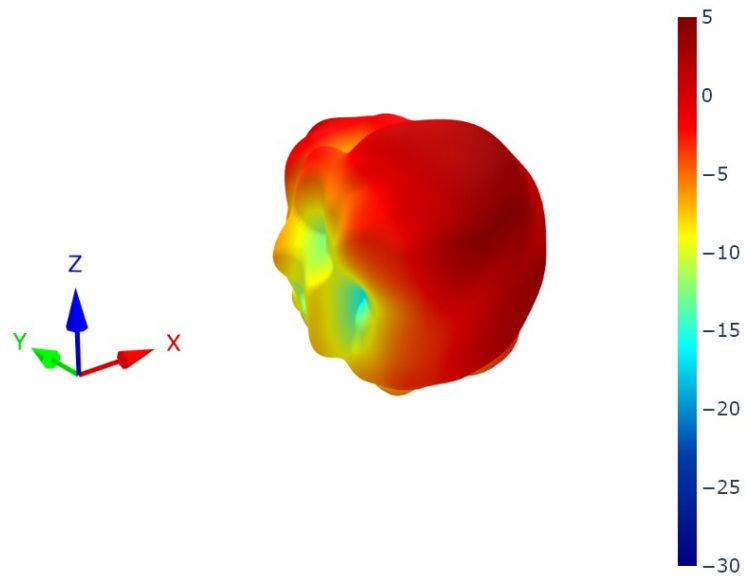

8.68 4G-5G 1 Patterns at 2595 MHz

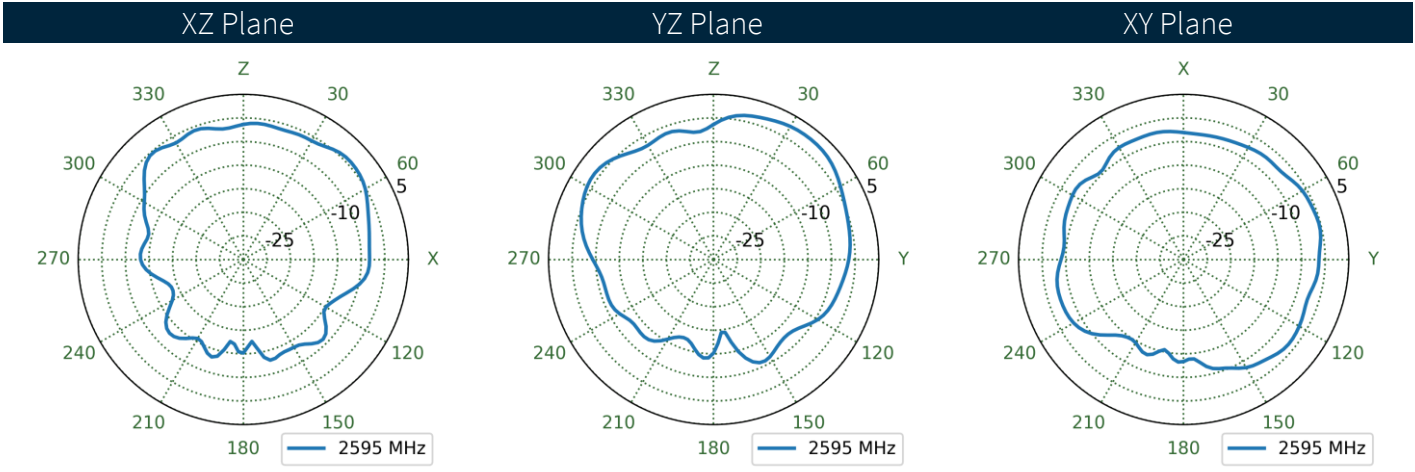
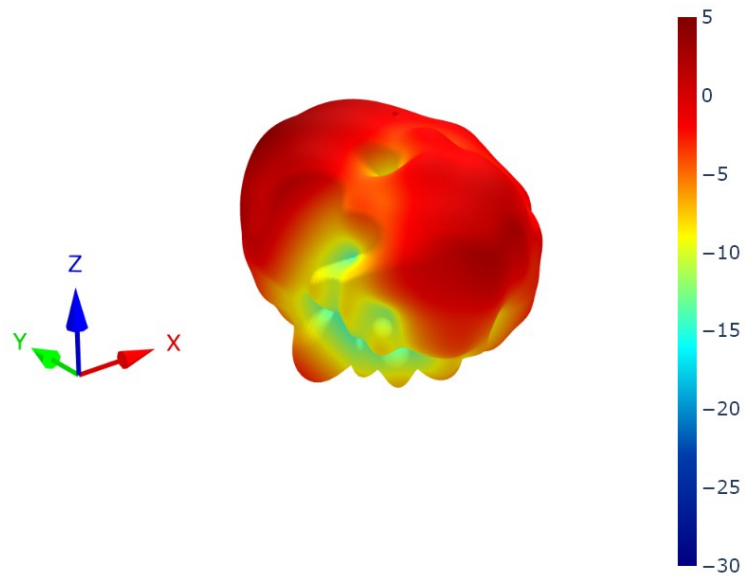

8.69 4G-5G 2 Patterns at 2595 MHz

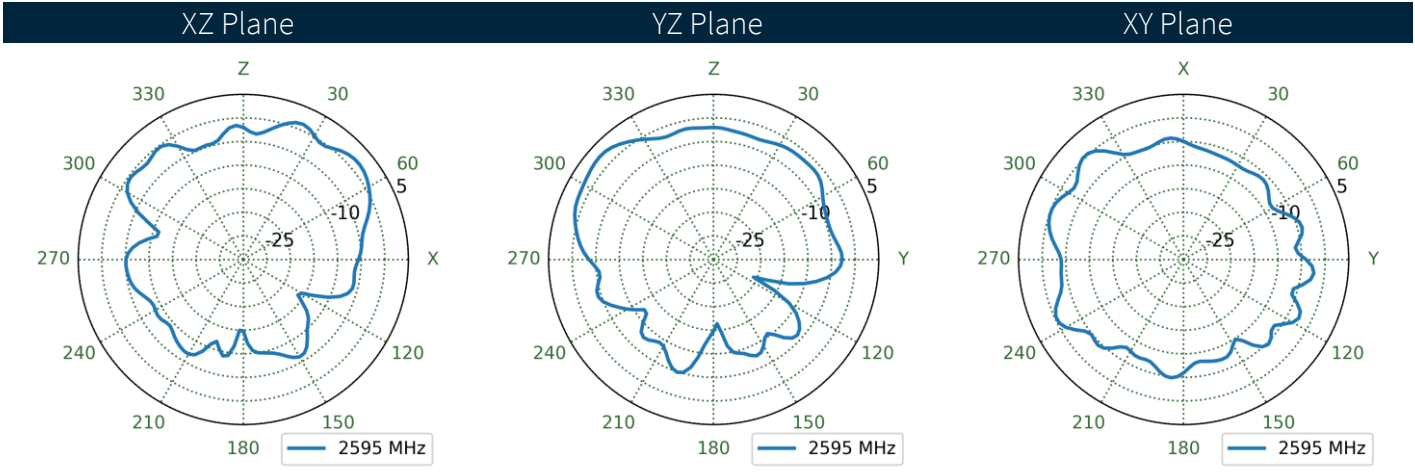
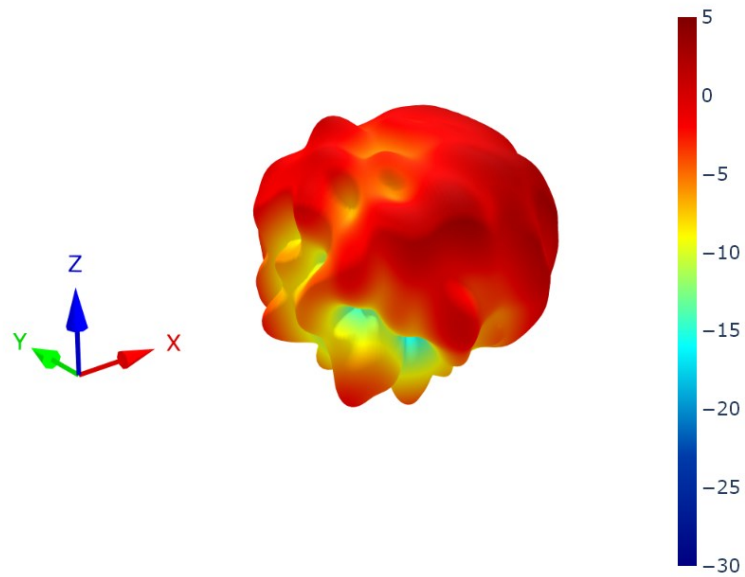

8.70 4G-5G 3 Patterns at 2595 MHz

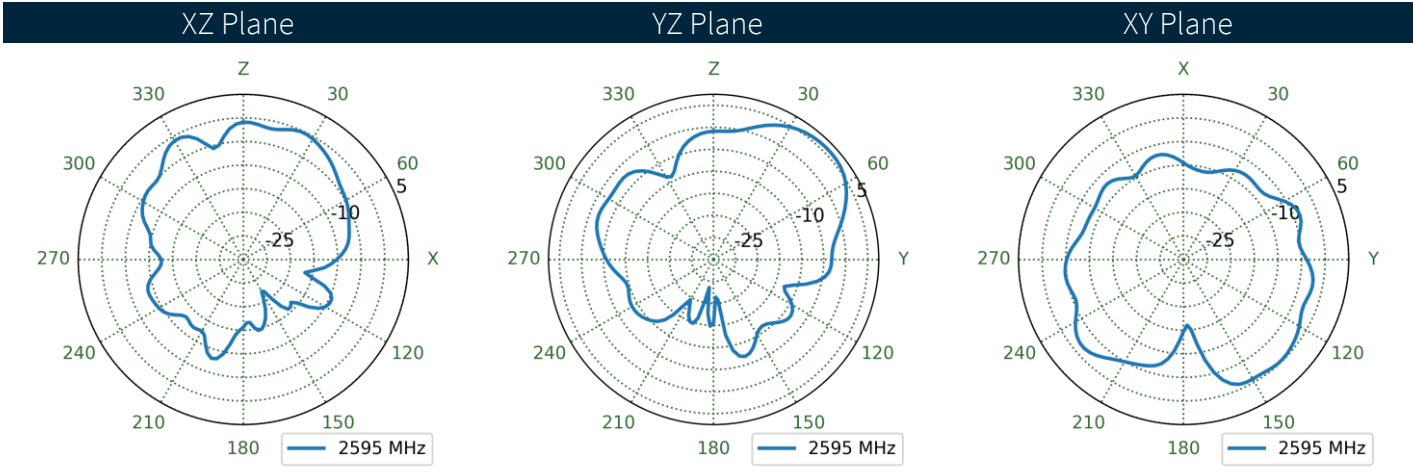
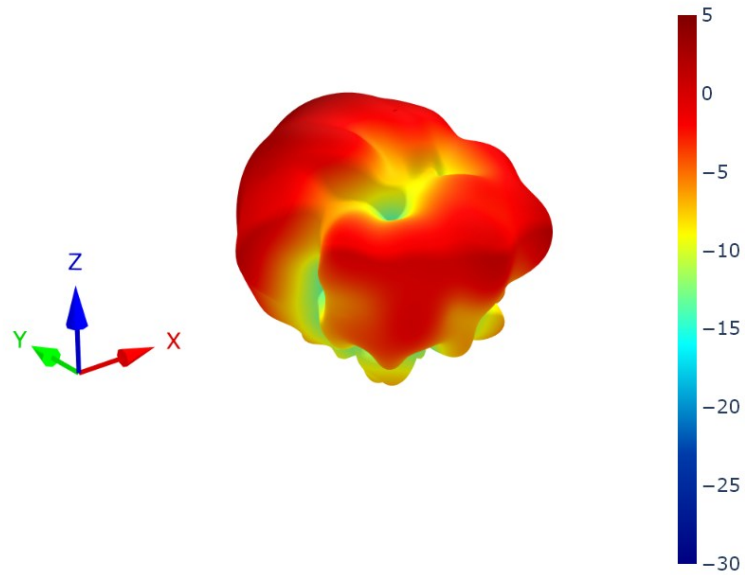

8.71 4G-5G 4 Patterns at 2595 MHz

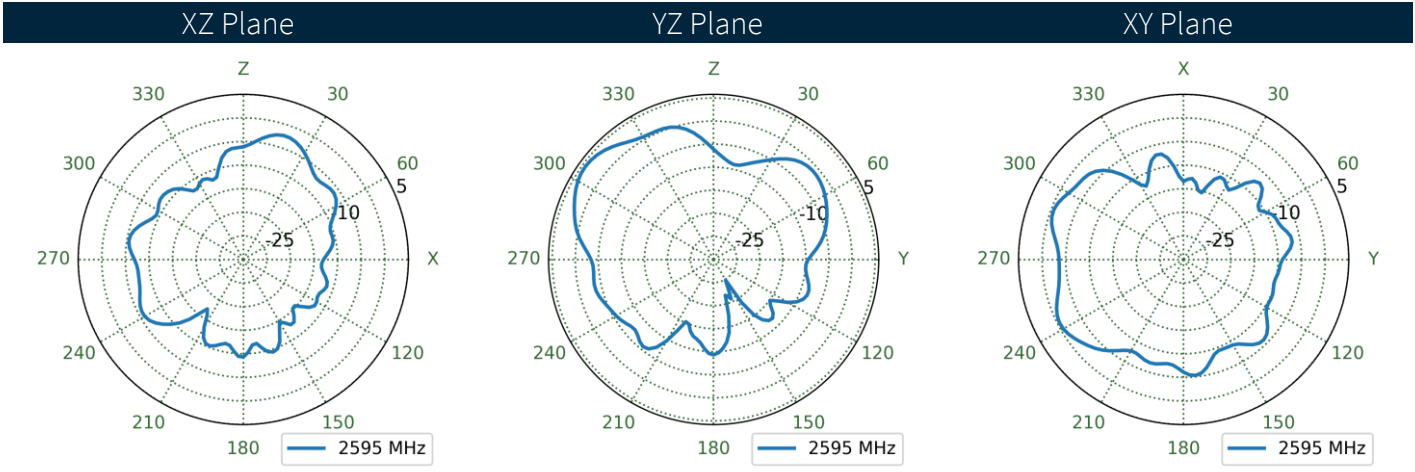
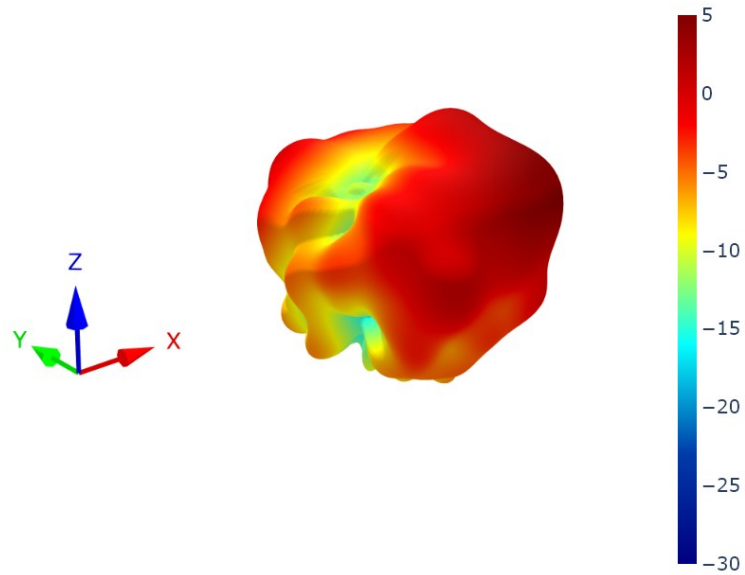

8.72 4G-5G 5 Patterns at 2595 MHz

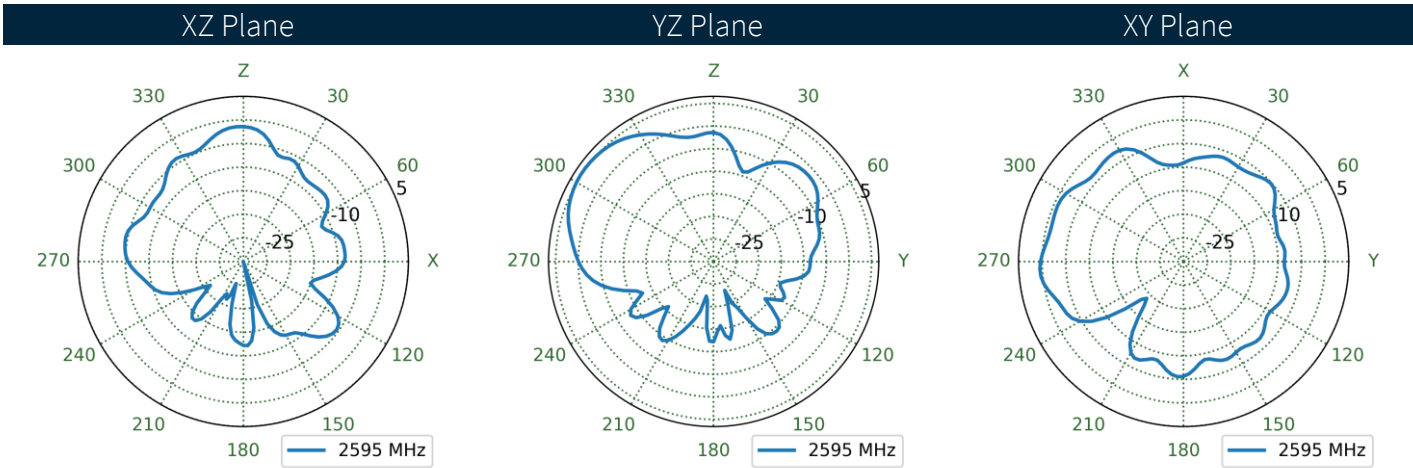
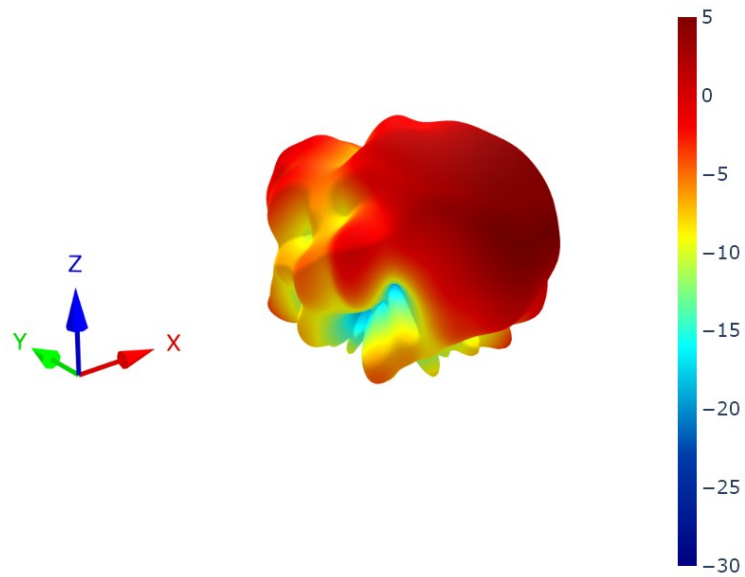

8.73 4G-5G 6 Patterns at 2595 MHz

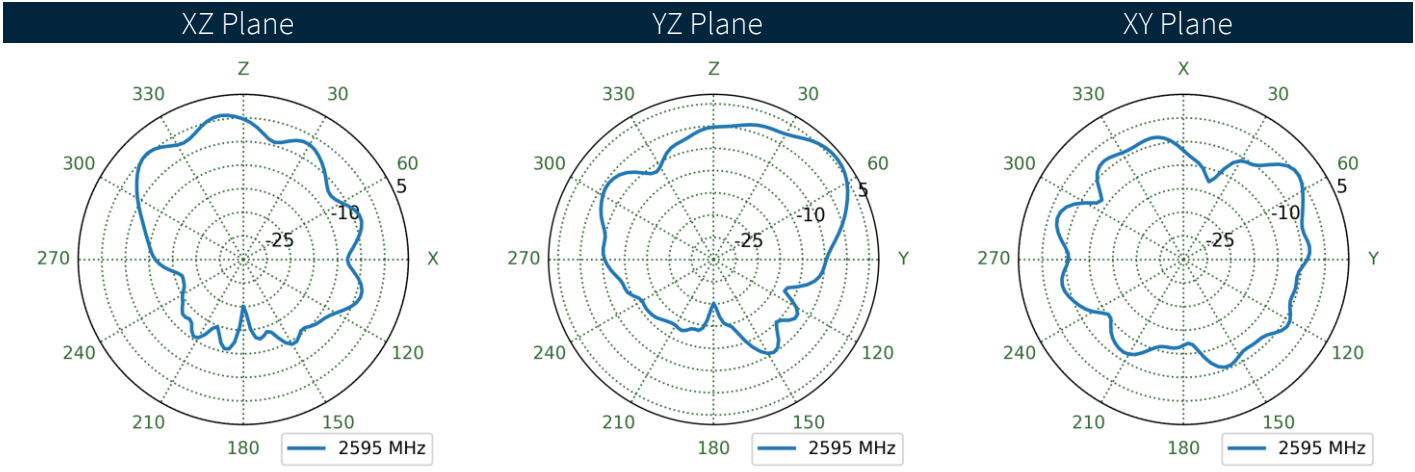
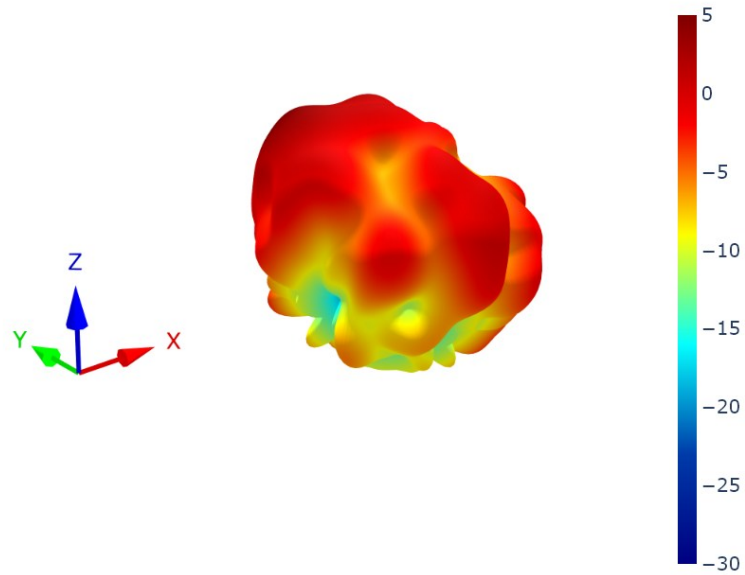

8.74 4G-5G 7 Patterns at 2595 MHz

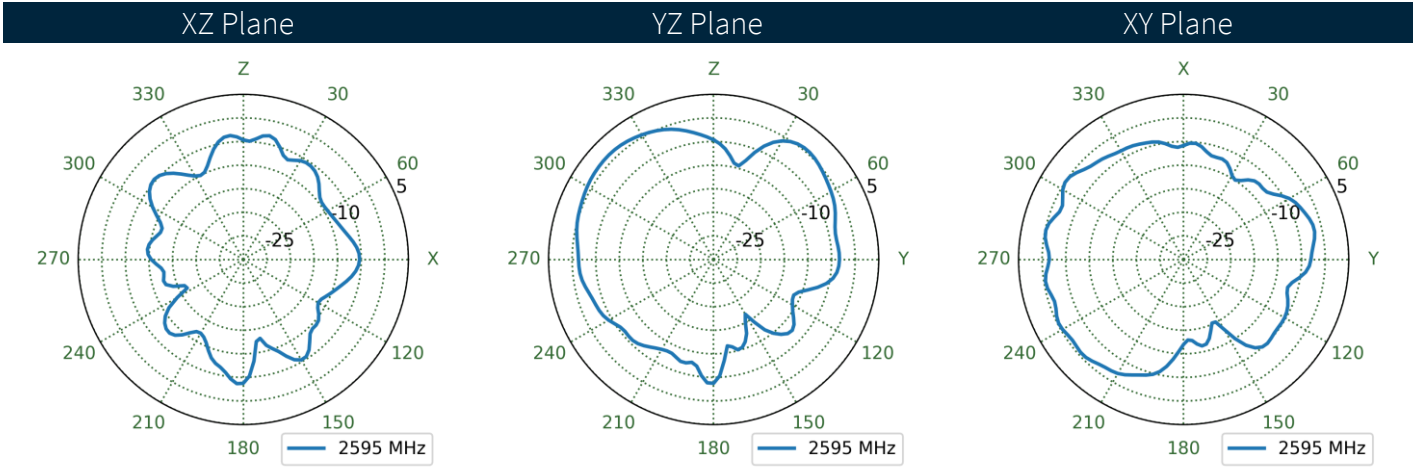
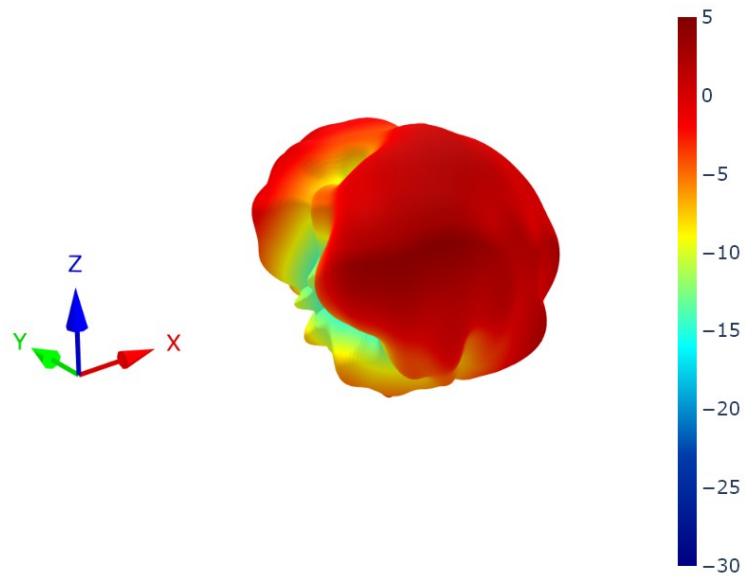

8.75 4G-5G 8 Patterns at 2595 MHz

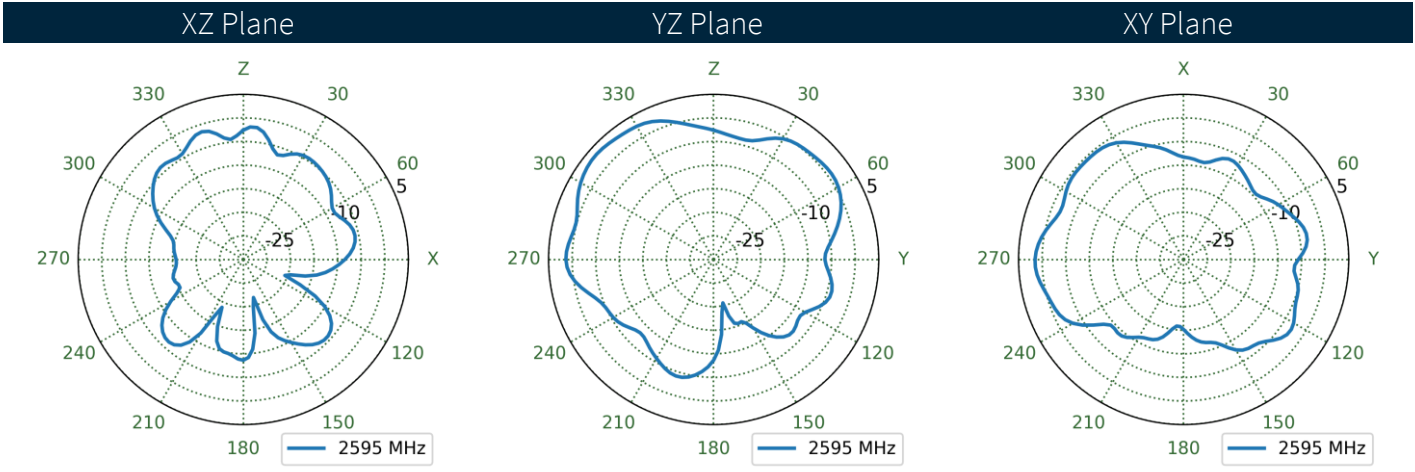
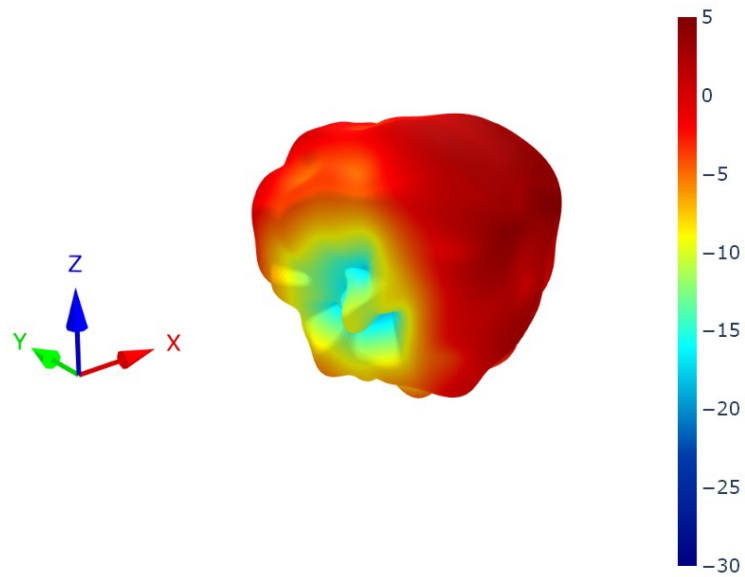

8.76 4G-5G 1 Patterns at 3550 MHz

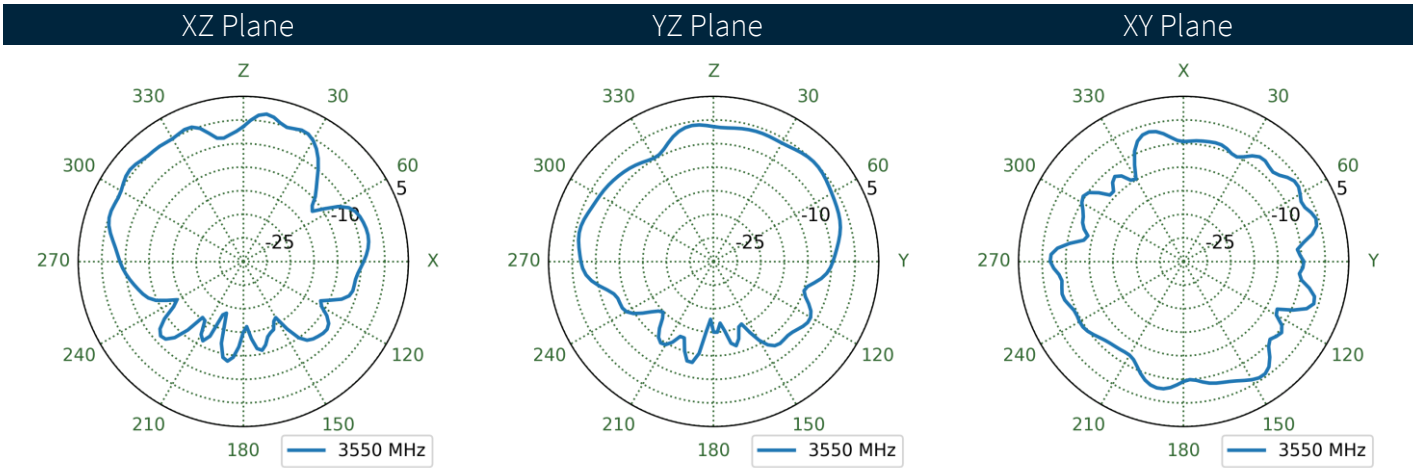
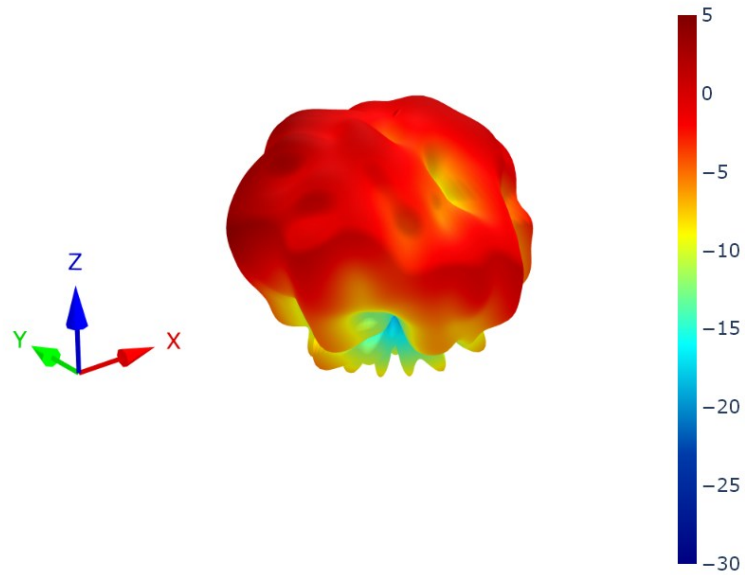

8.77 4G-5G 2 Patterns at 3550 MHz

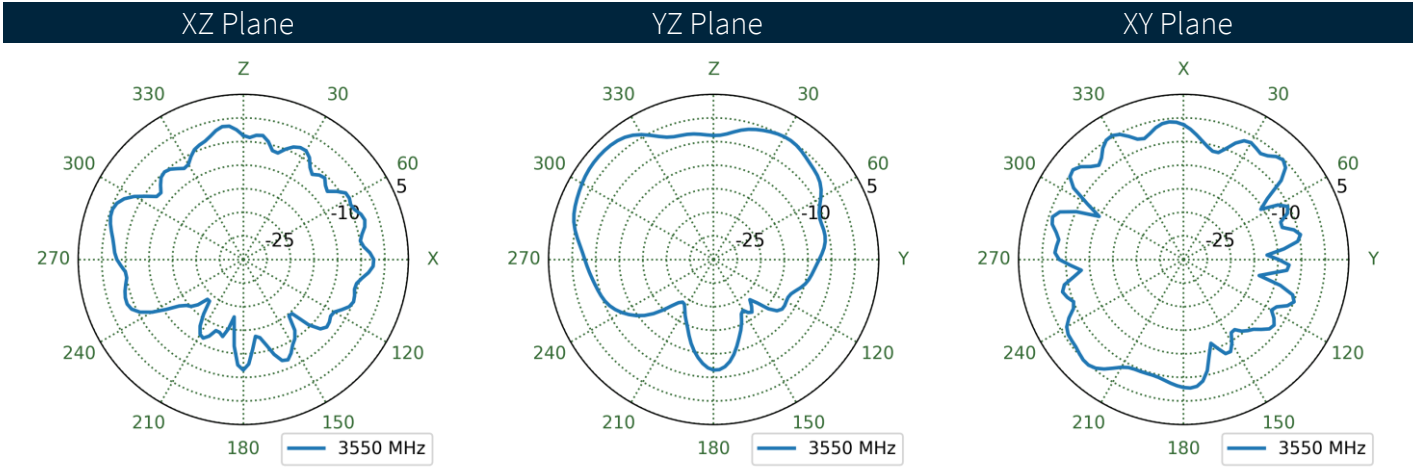
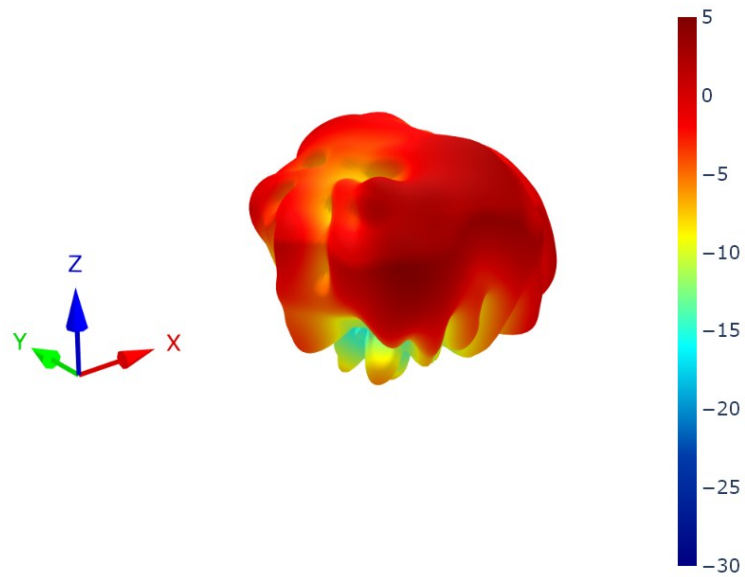

8.78 4G-5G 3 Patterns at 3550 MHz

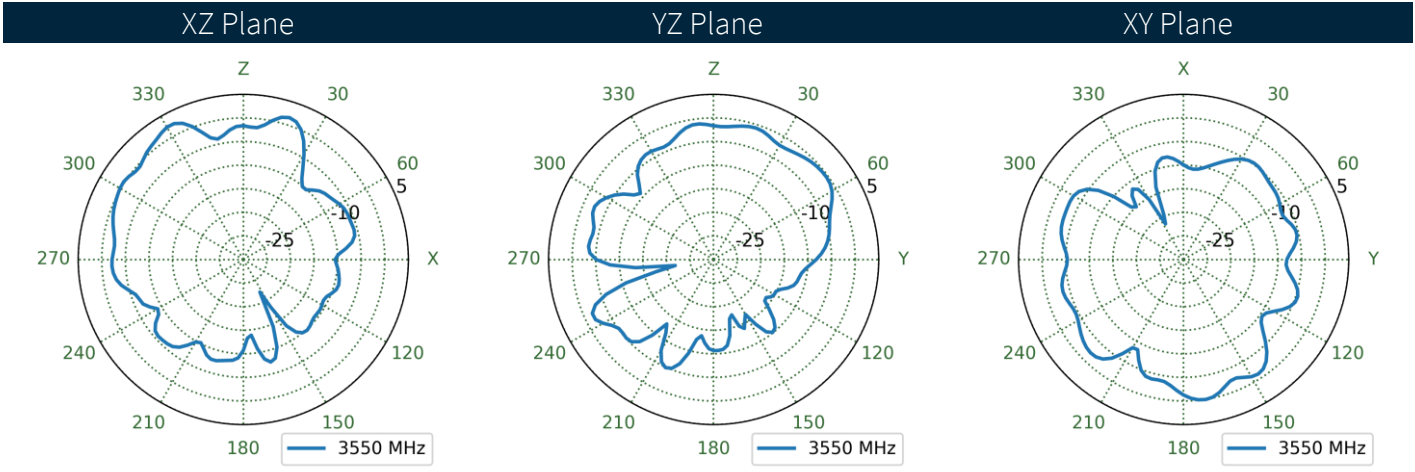
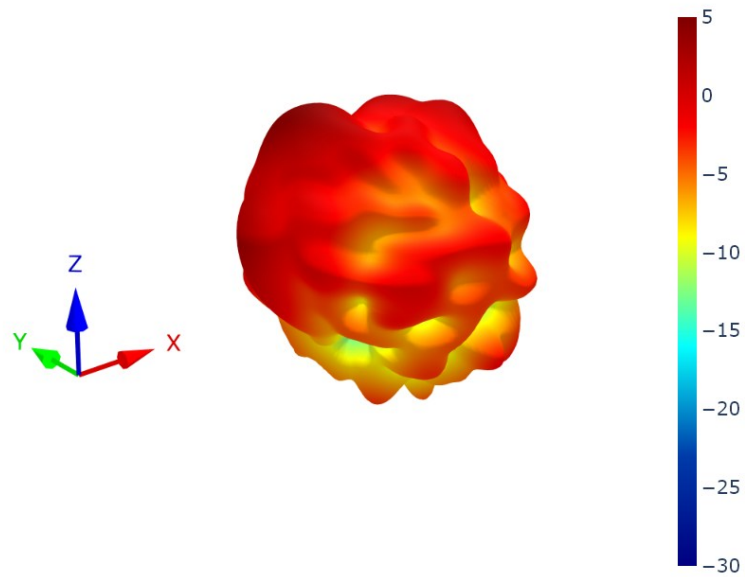

8.79 4G-5G 4 Patterns at 3550 MHz

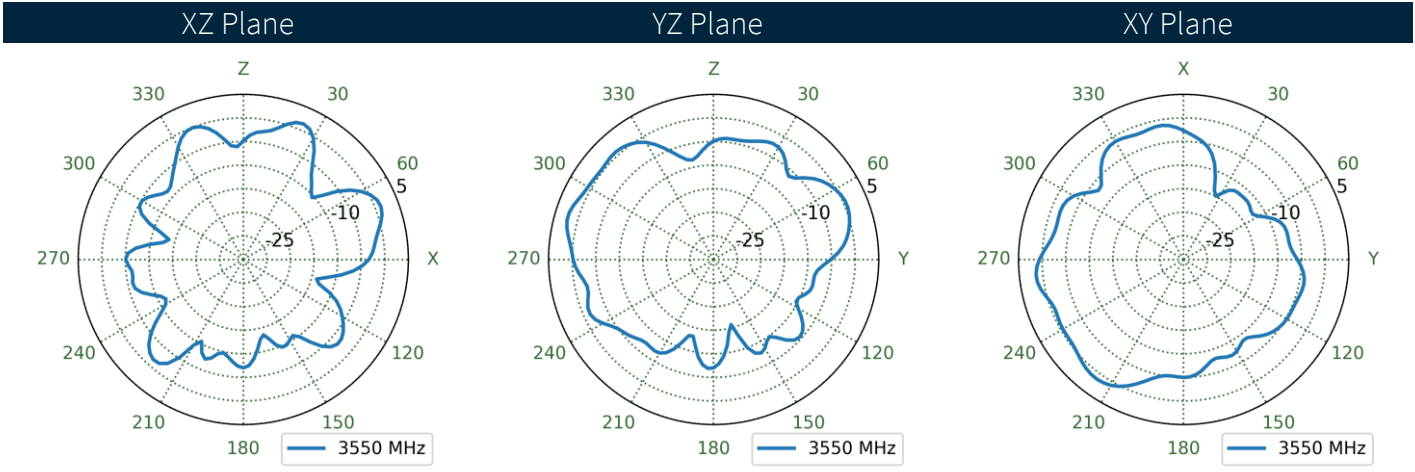
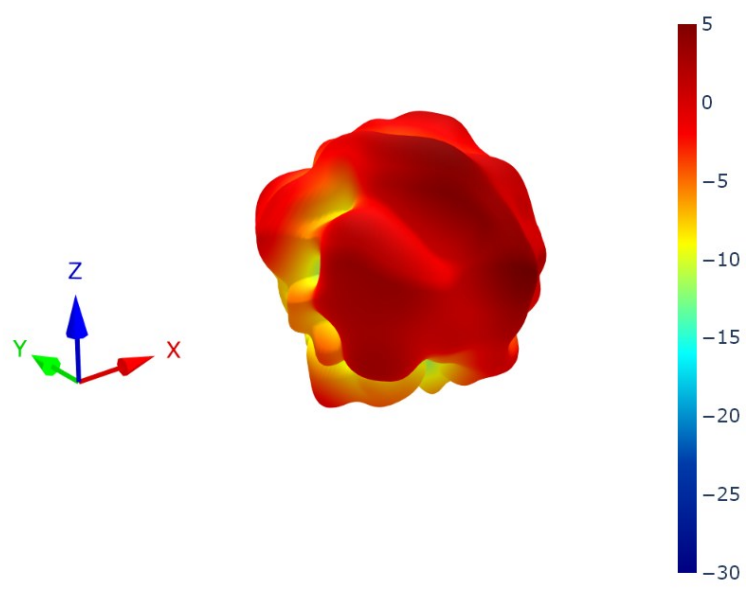

8.80 4G-5G 5 Patterns at 3550 MHz

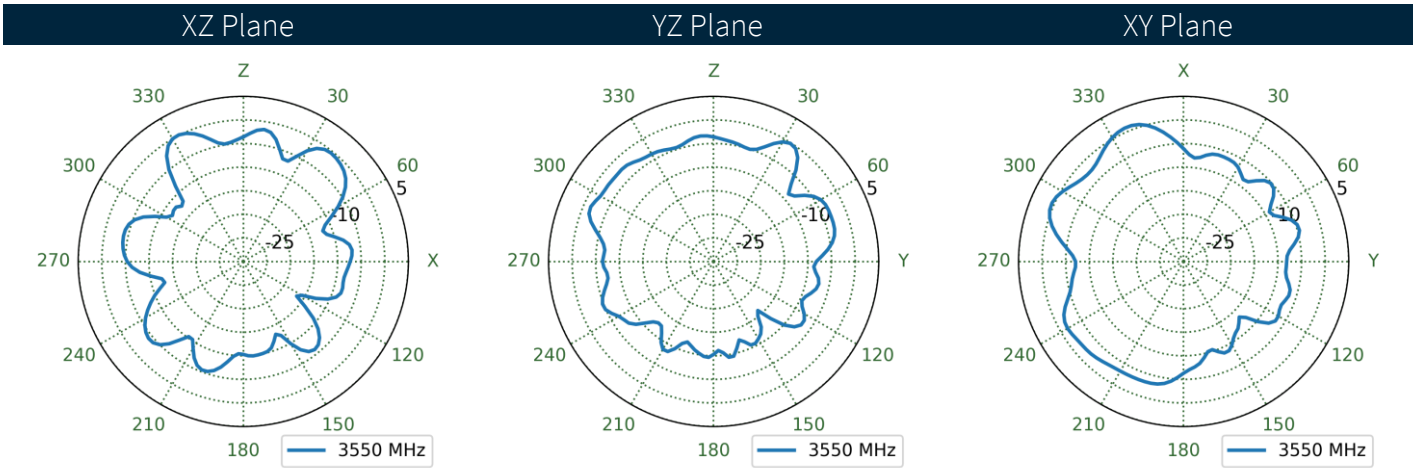
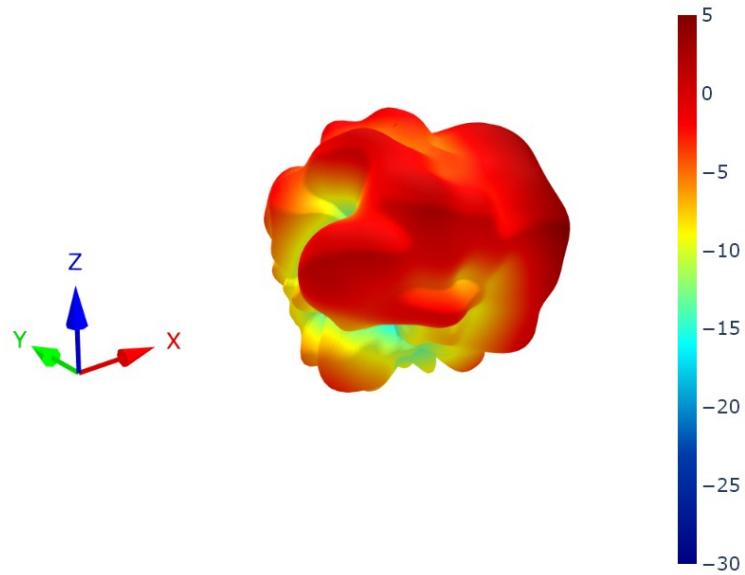

8.81 4G-5G 6 Patterns at 3550 MHz

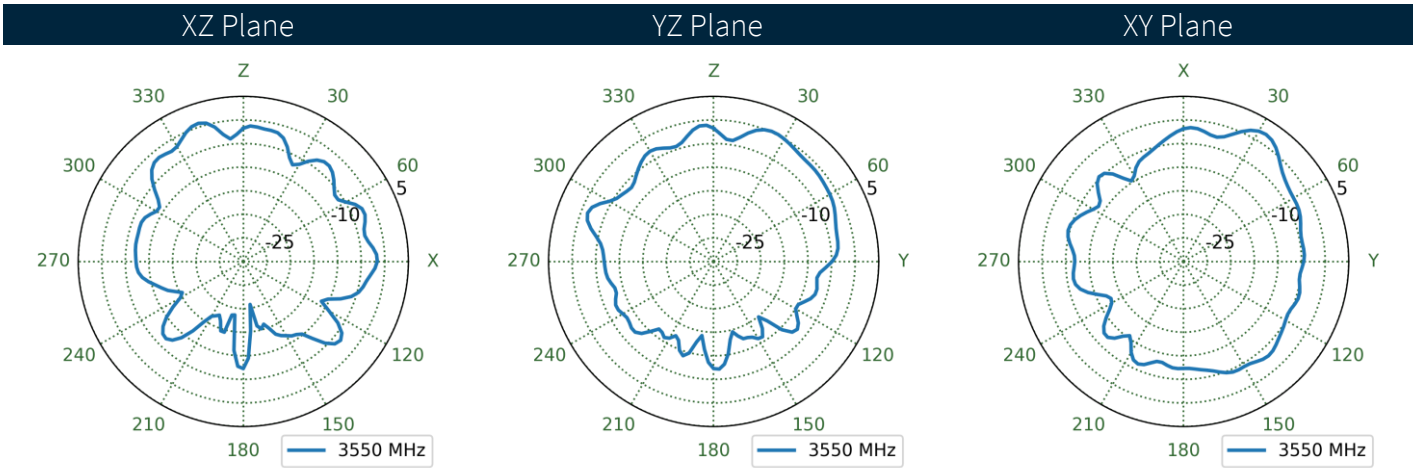
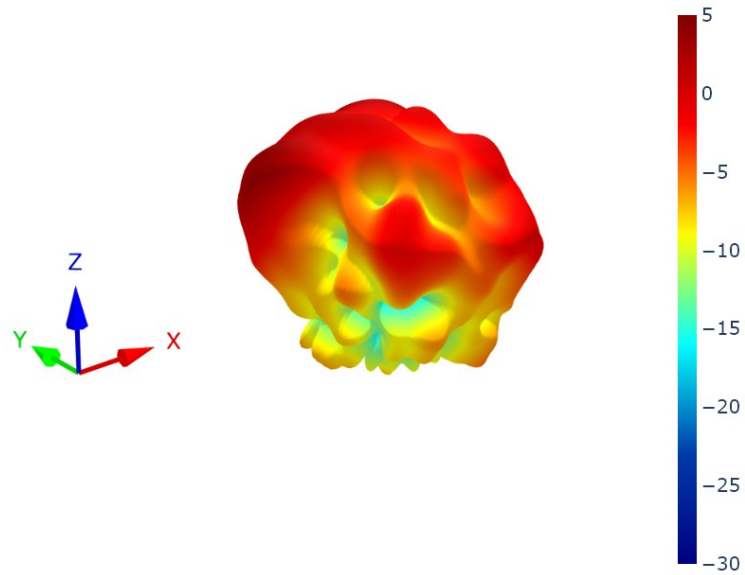

8.82 4G-5G 7 Patterns at 3550 MHz

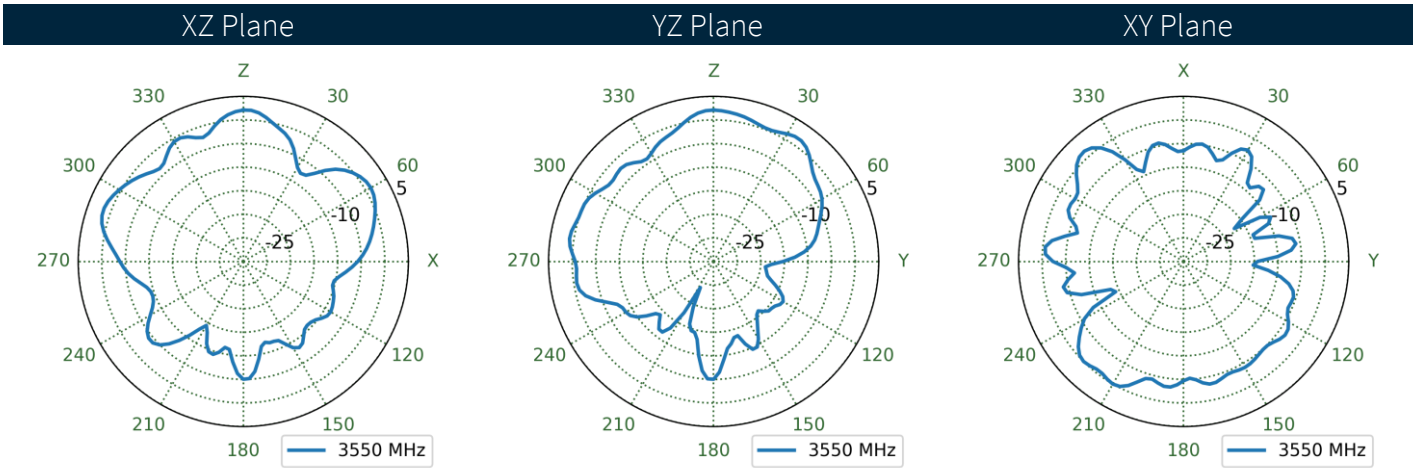
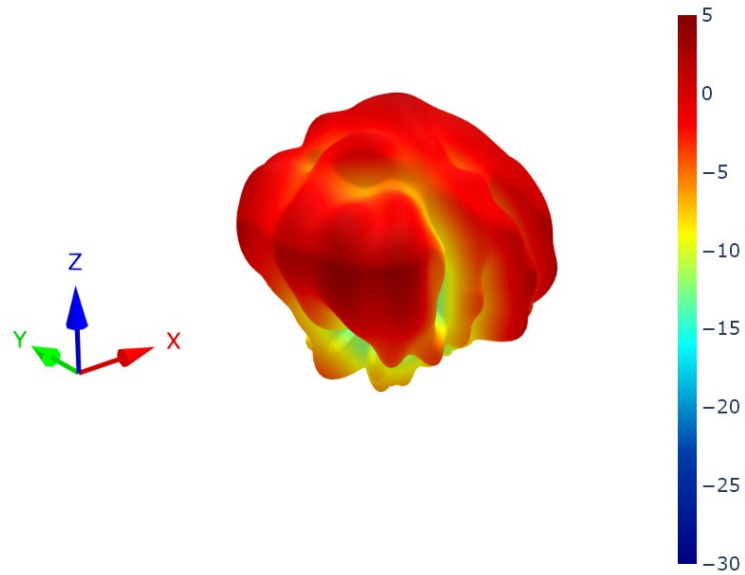

8.83 4G-5G 8 Patterns at 3550 MHz

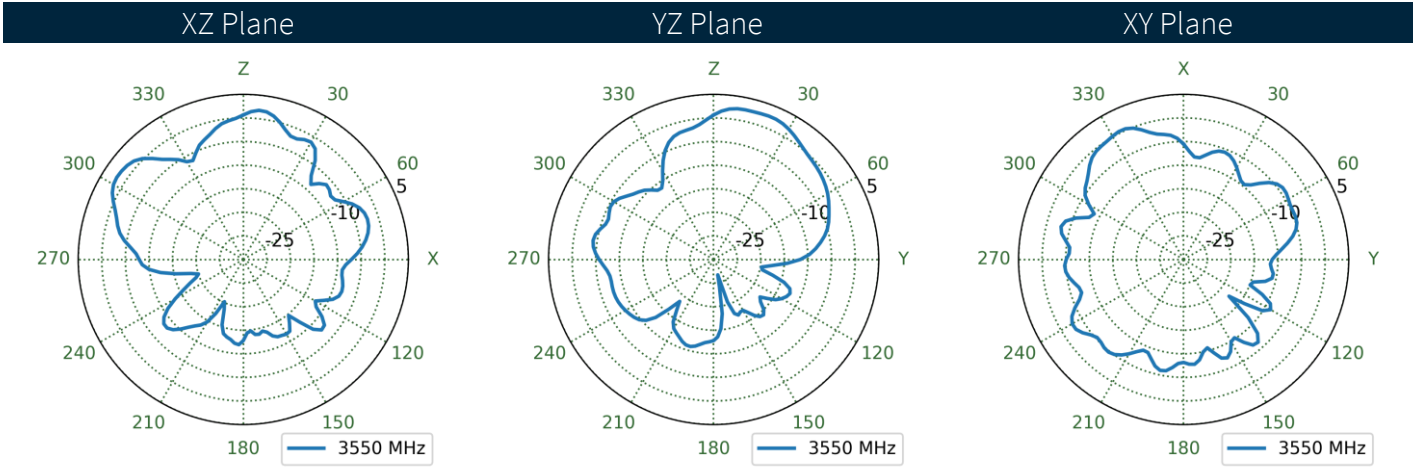
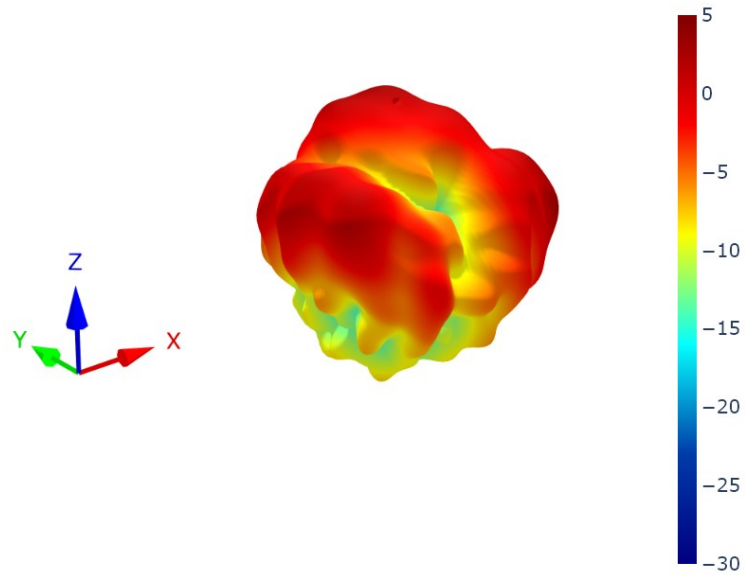

8.84 4G-5G 1 Patterns at 4600 MHz

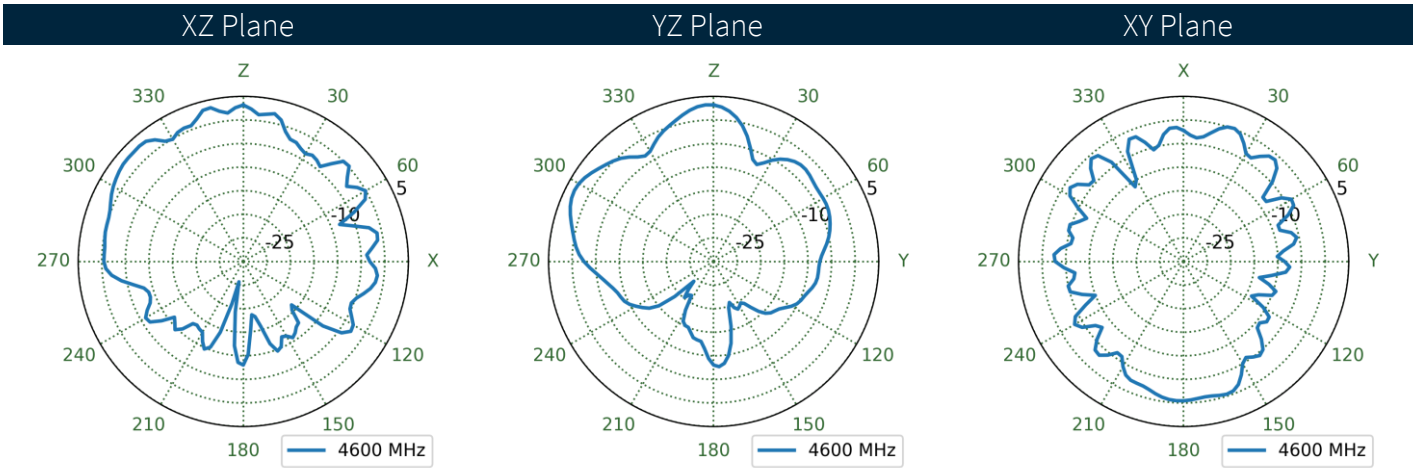
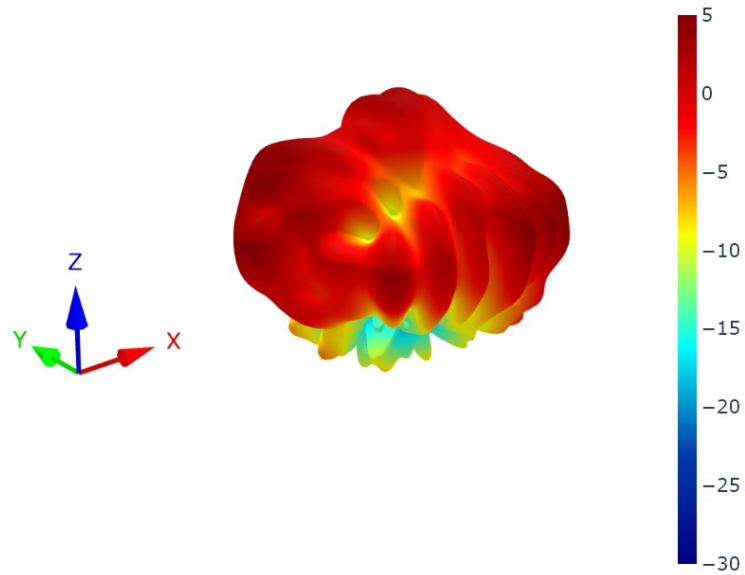

8.85 4G-5G 2 Patterns at 4600 MHz

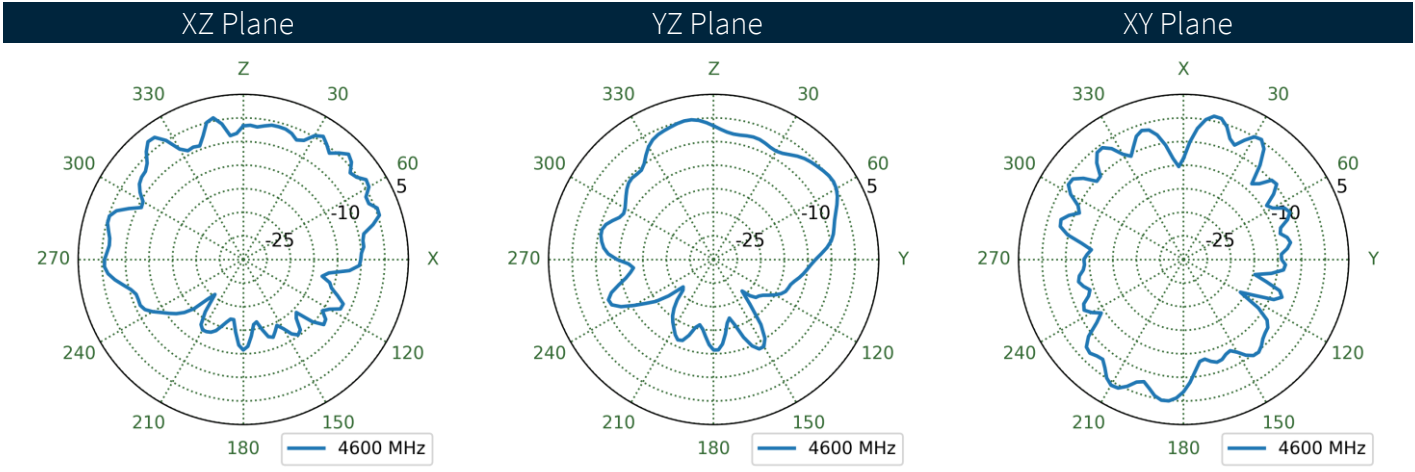
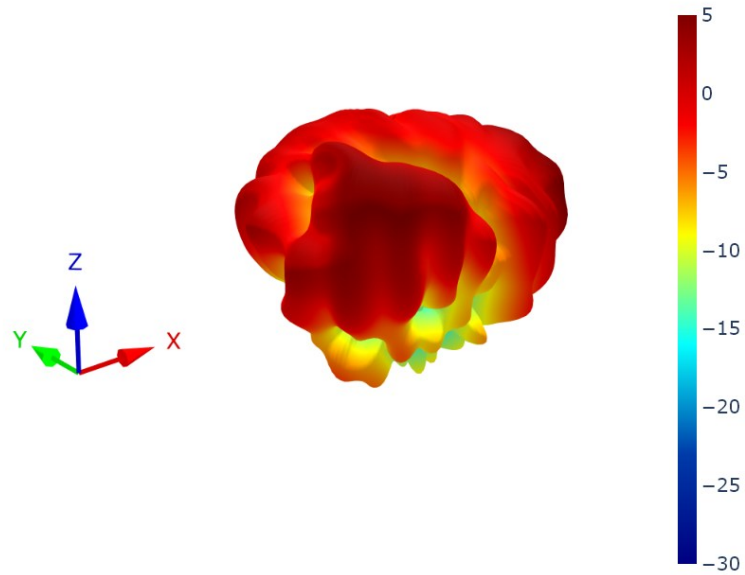

8.86 4G-5G 3 Patterns at 4600 MHz

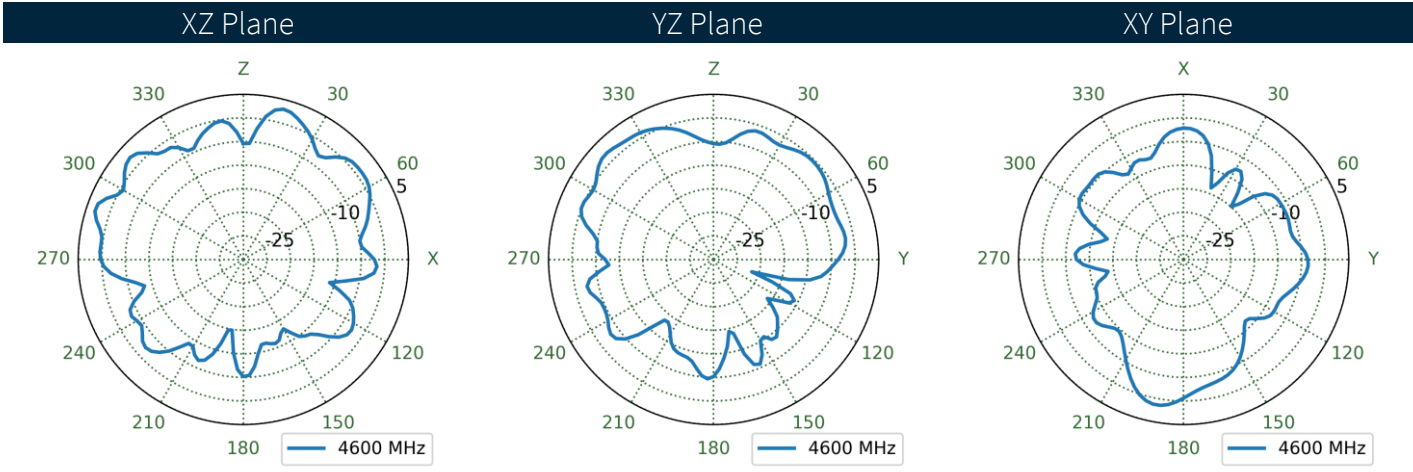
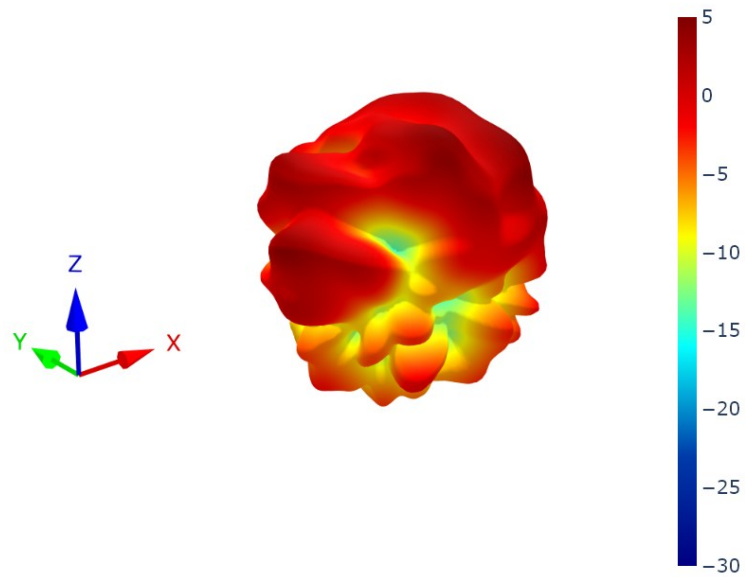

8.87 4G-5G 4 Patterns at 4600 MHz

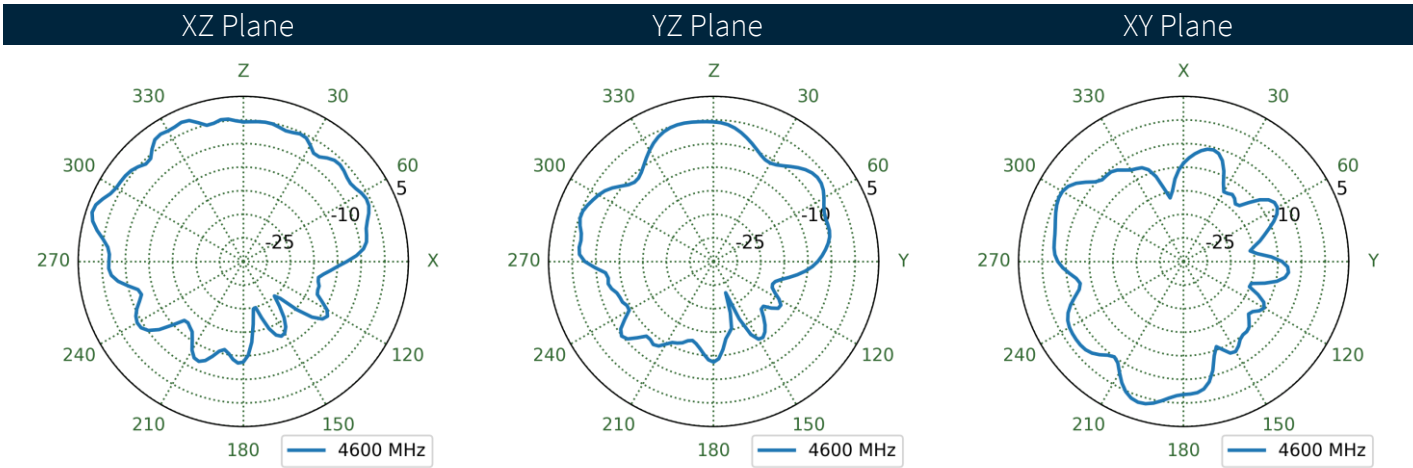
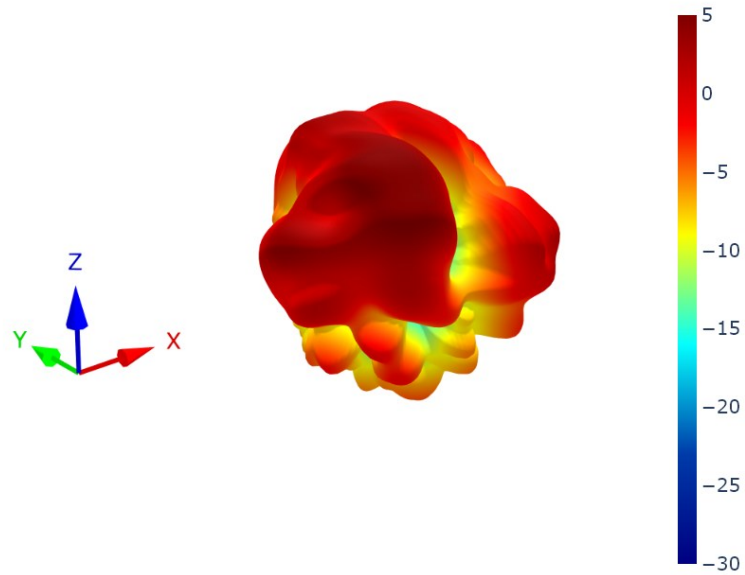

8.88 4G-5G 5 Patterns at 4600 MHz

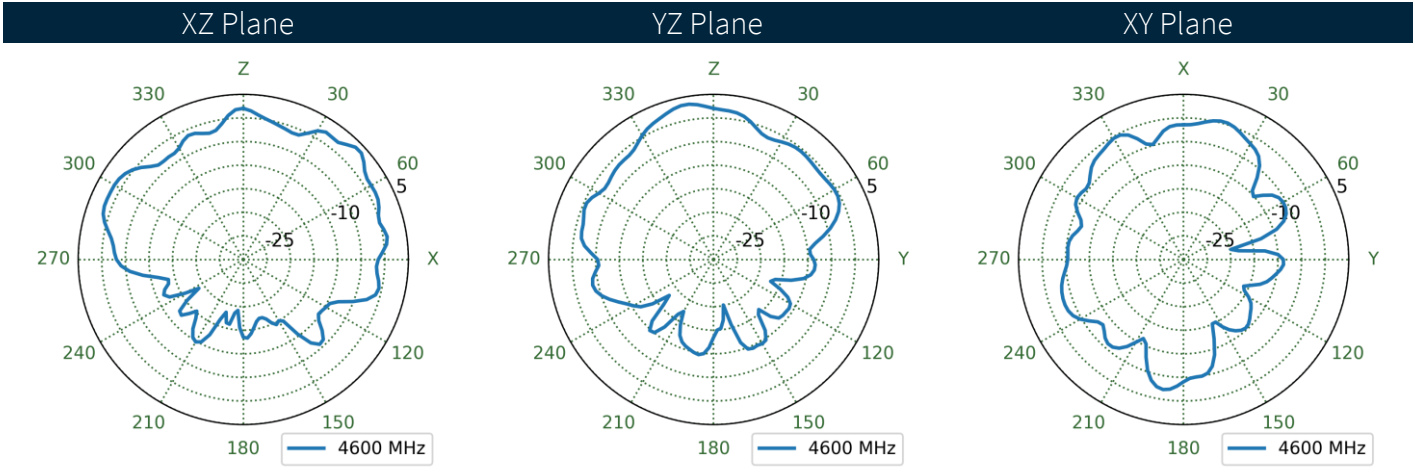
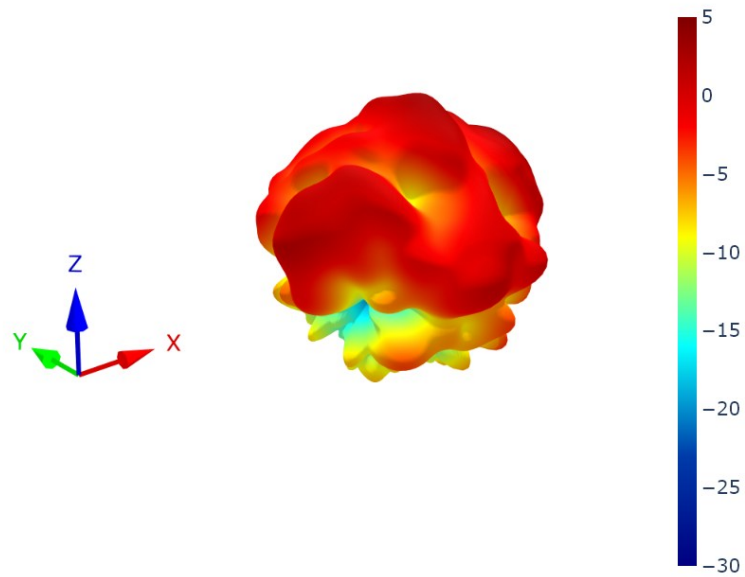

8.89 4G-5G 6 Patterns at 4600 MHz

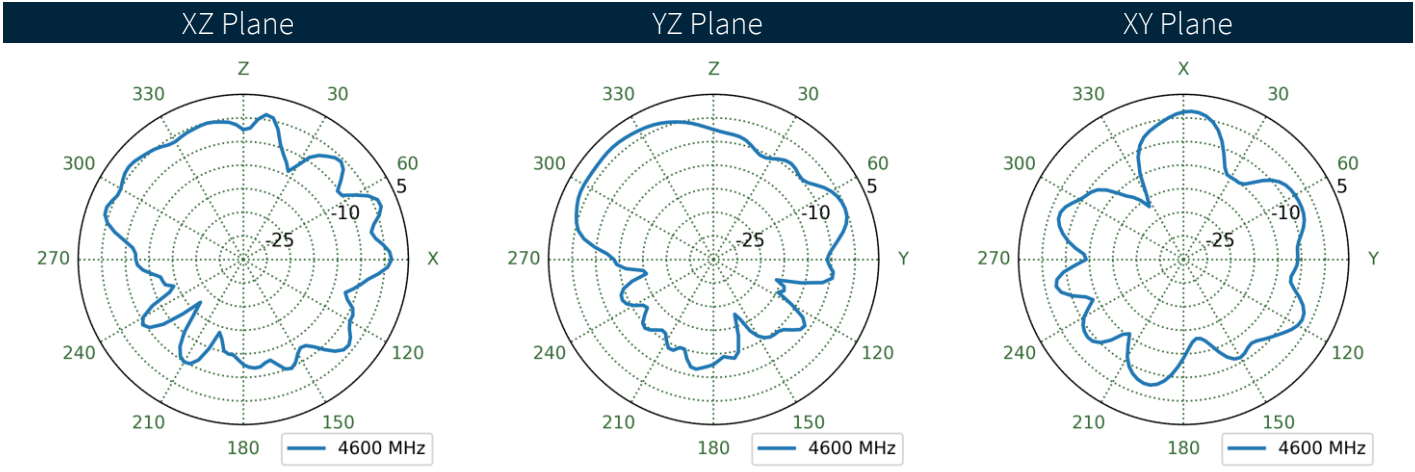
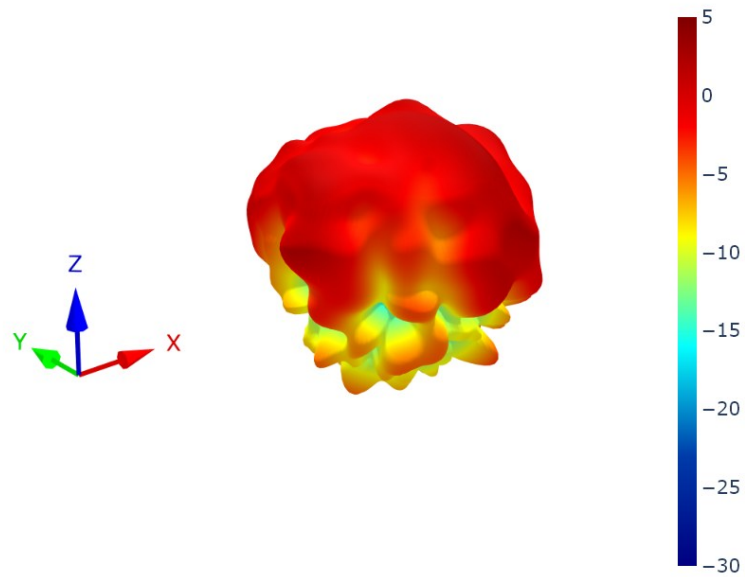

8.90 4G-5G 7 Patterns at 4600 MHz

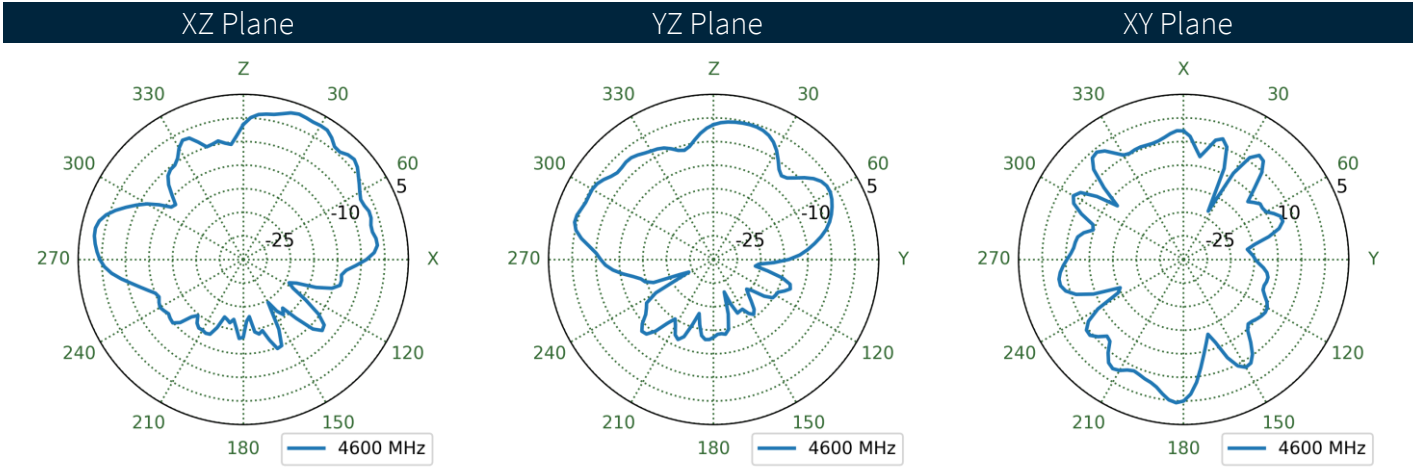
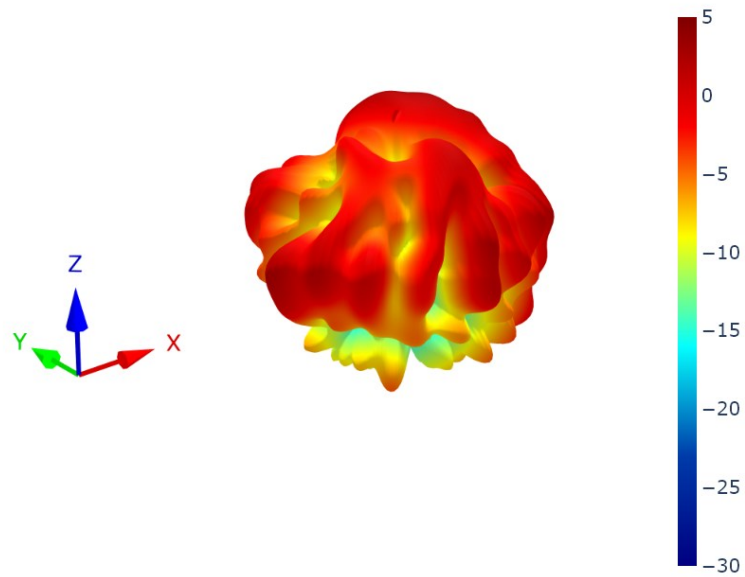

8.91 4G-5G 8 Patterns at 4600 MHz

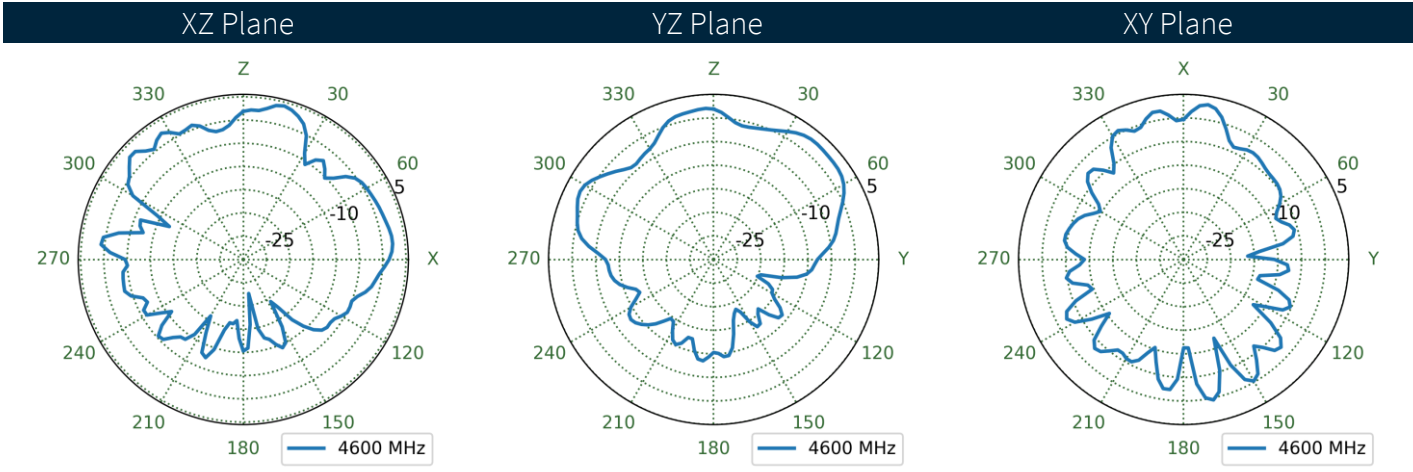
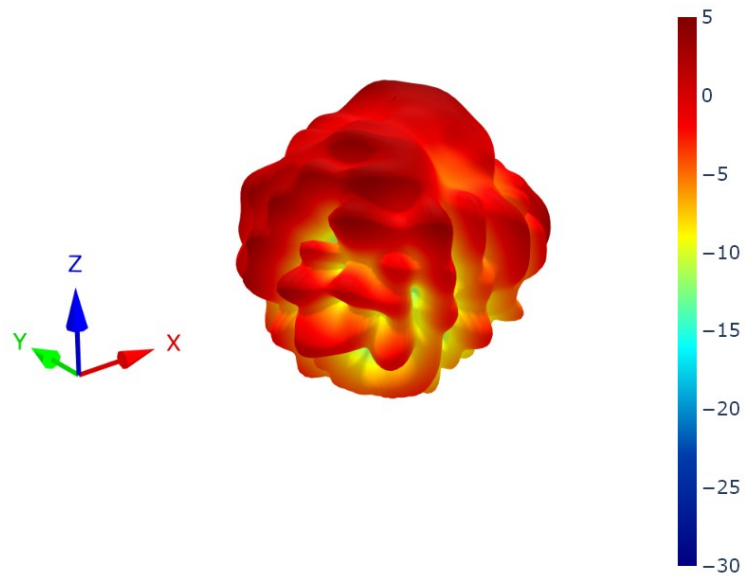

8.92 4G-5G 1 Patterns at 4800 MHz

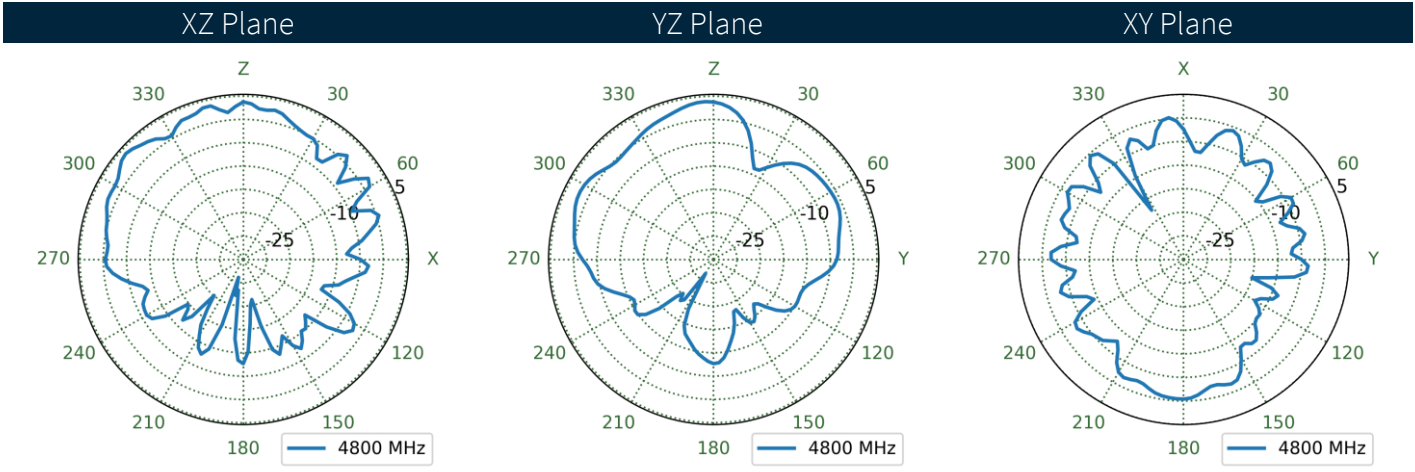
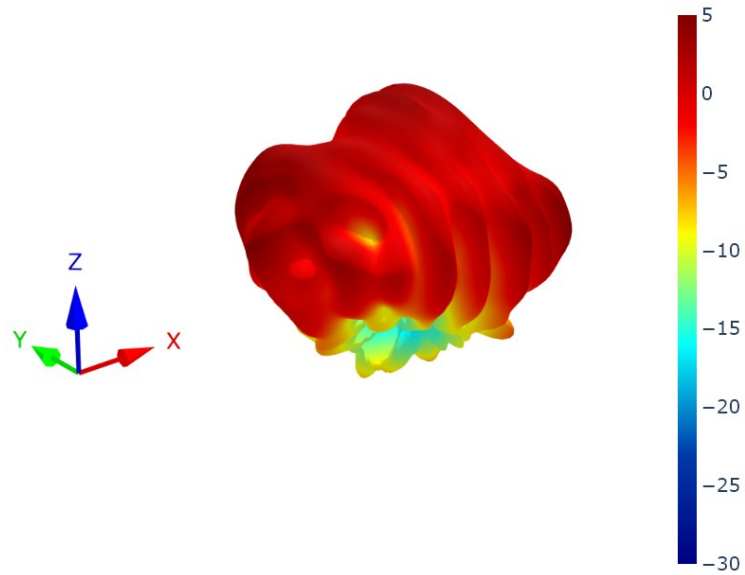

8.93 4G-5G 2 Patterns at 4800 MHz

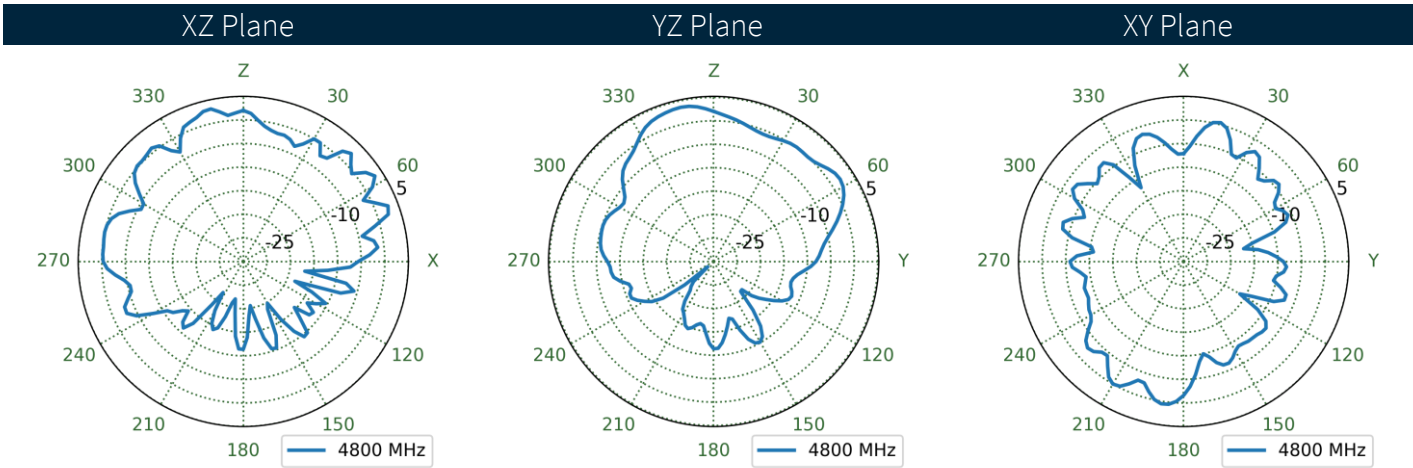
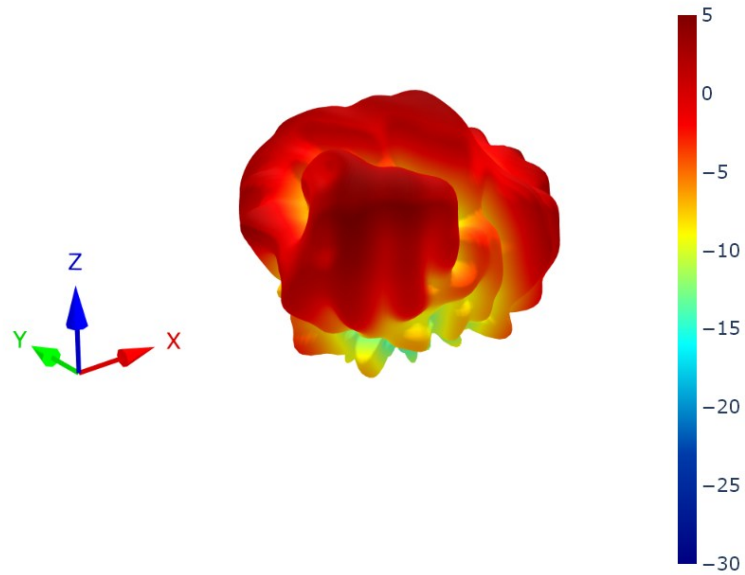

8.94 4G-5G 3 Patterns at 4800 MHz

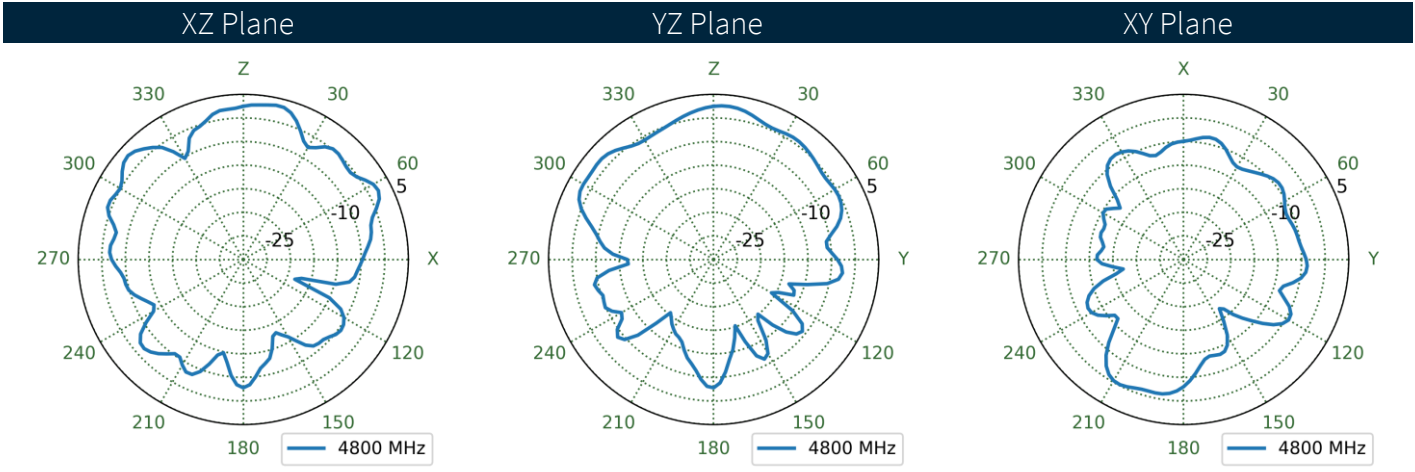
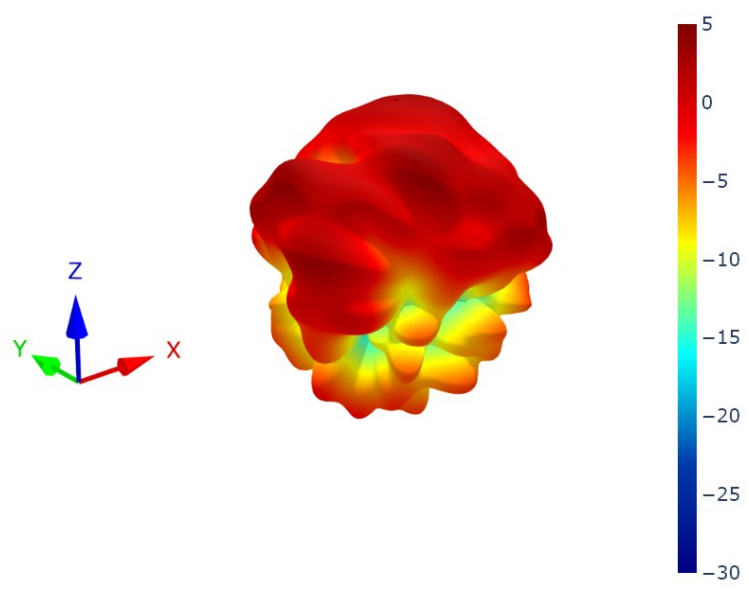

8.95 4G-5G 4 Patterns at 4800 MHz

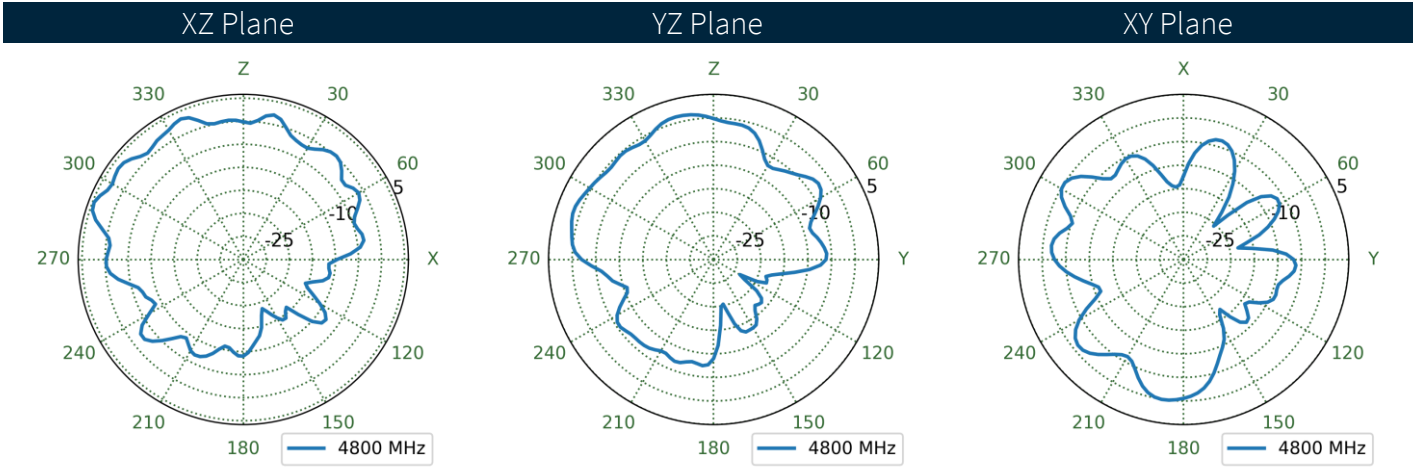
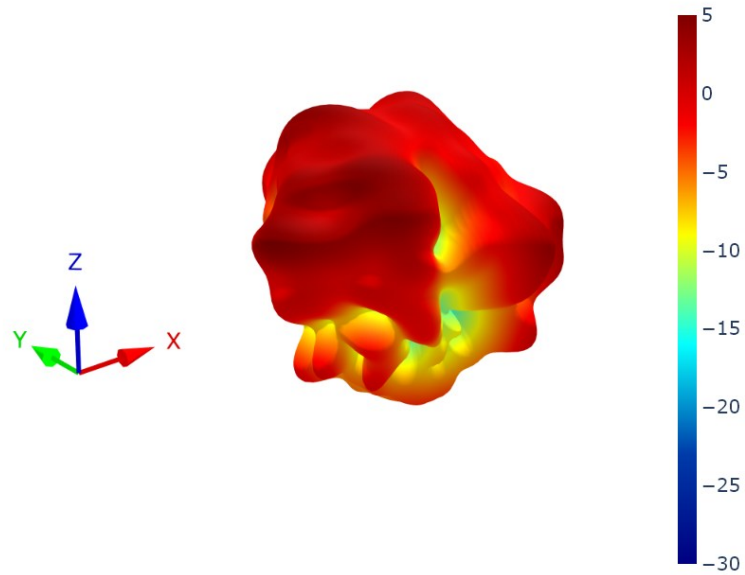

8.96 4G-5G 5 Patterns at 4800 MHz

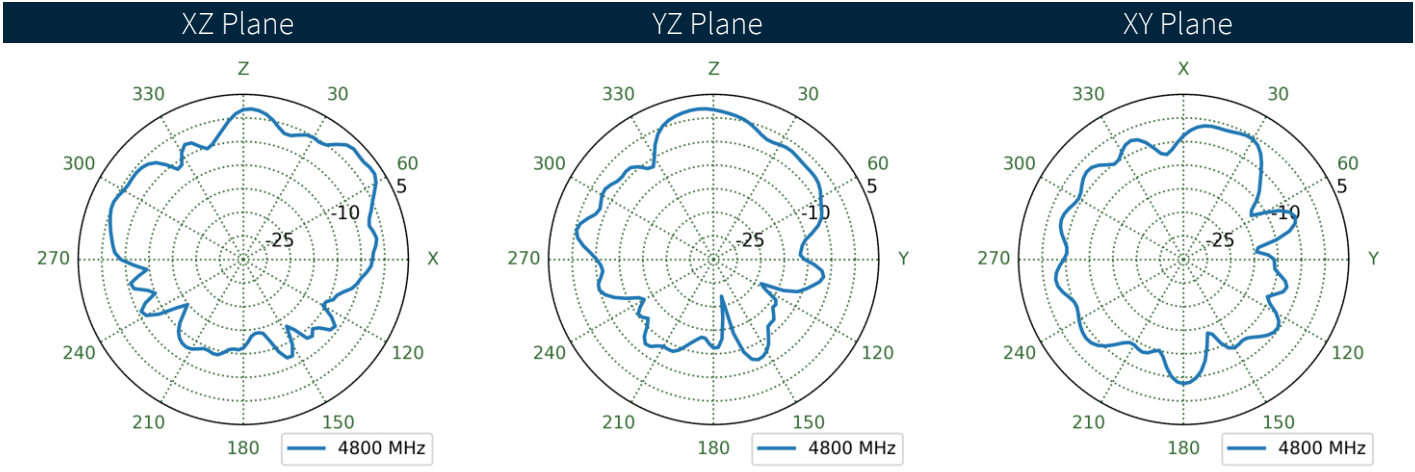
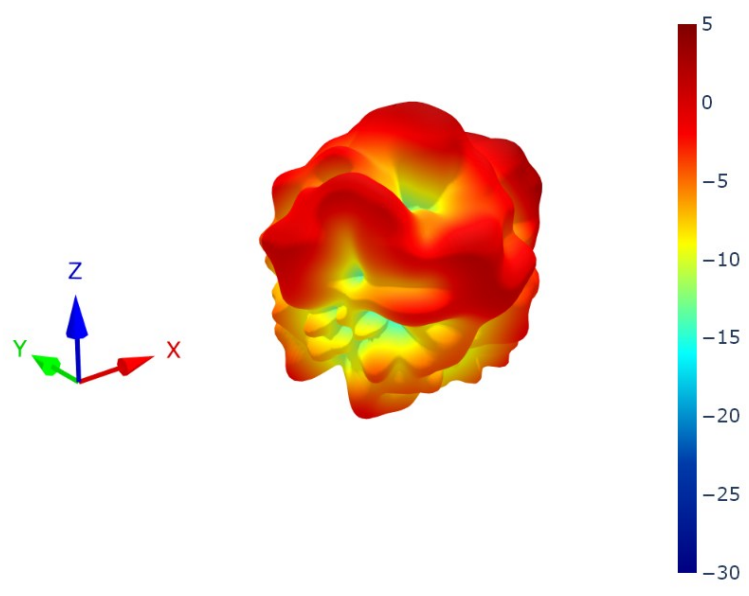

8.97 4G-5G 6 Patterns at 4800 MHz

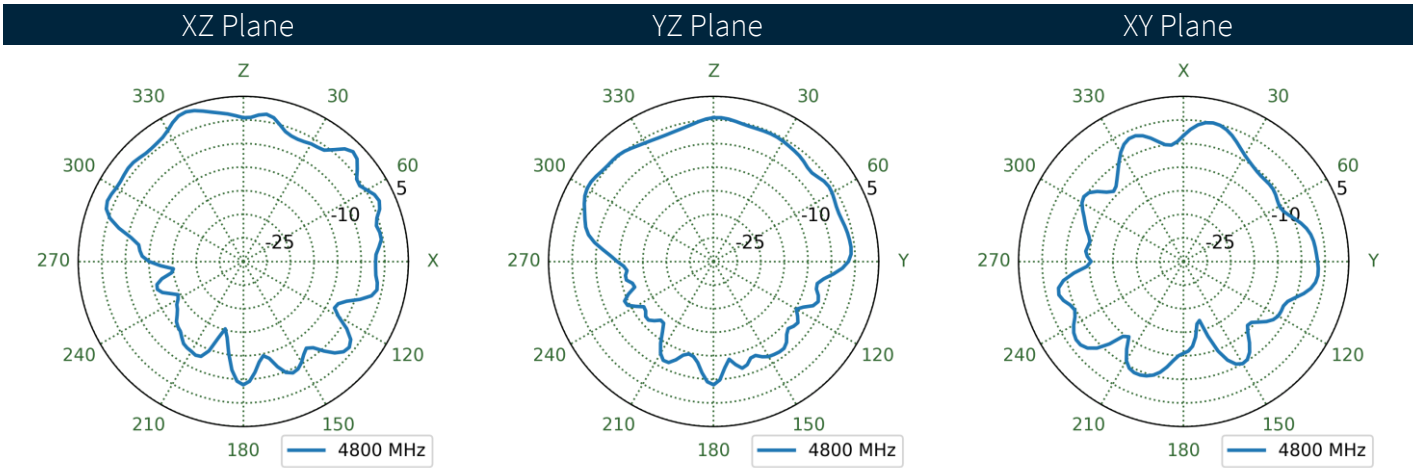
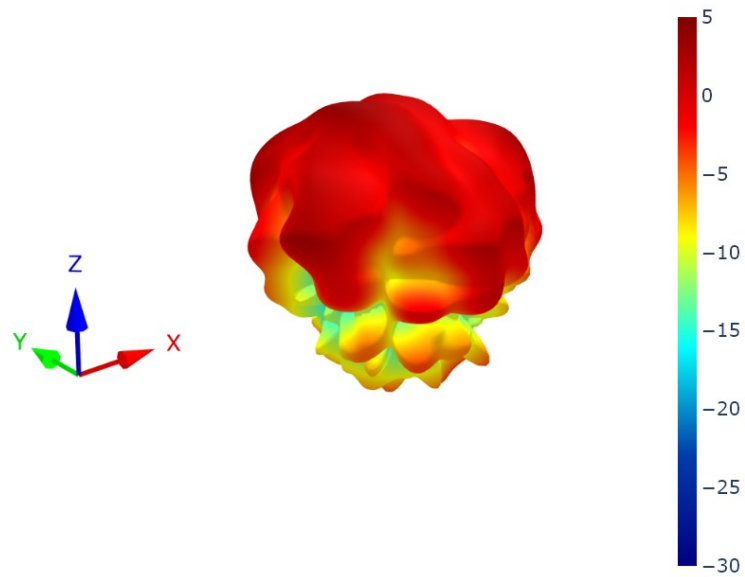

8.98 4G-5G 7 Patterns at 4800 MHz

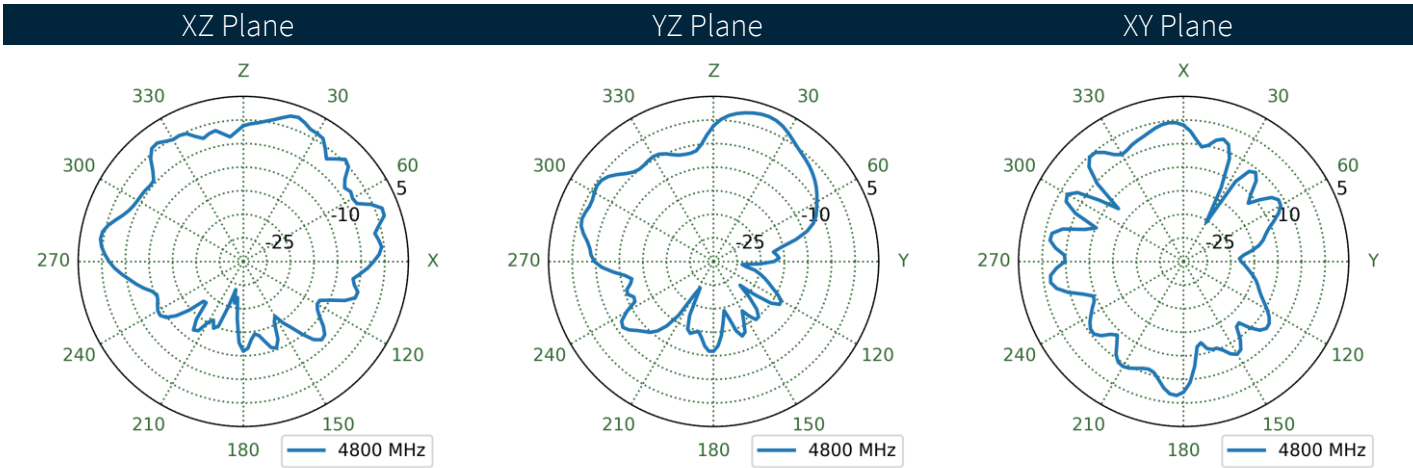
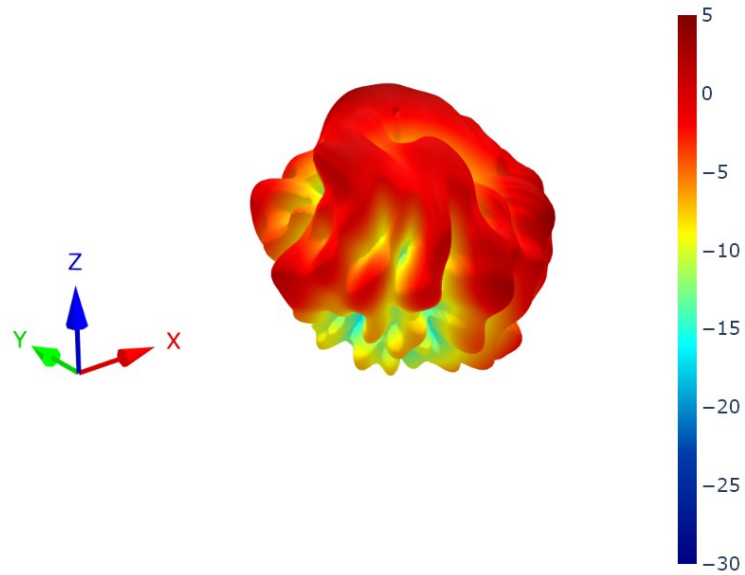

8.99 4G-5G 8 Patterns at 4800 MHz

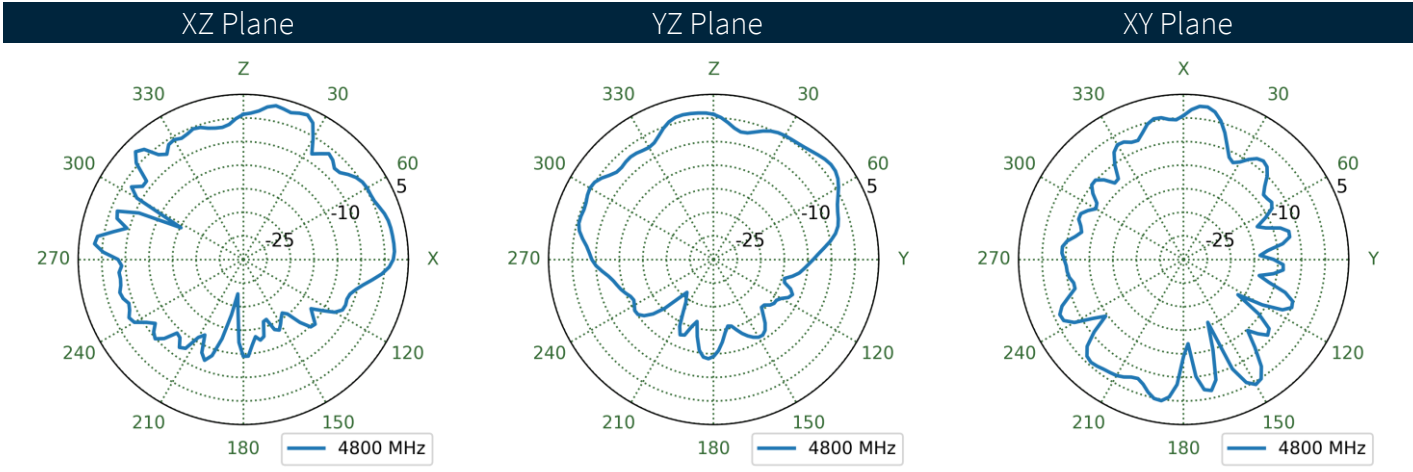
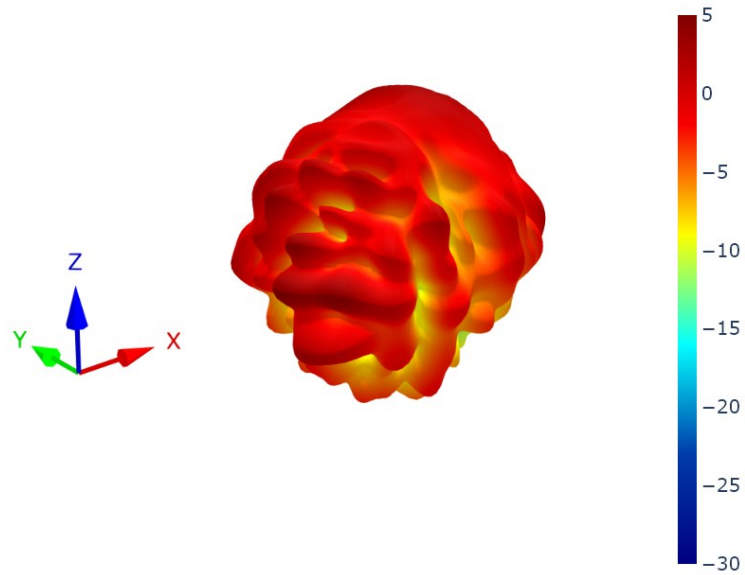

8.100 4G-5G 1 Patterns at 5530 MHz

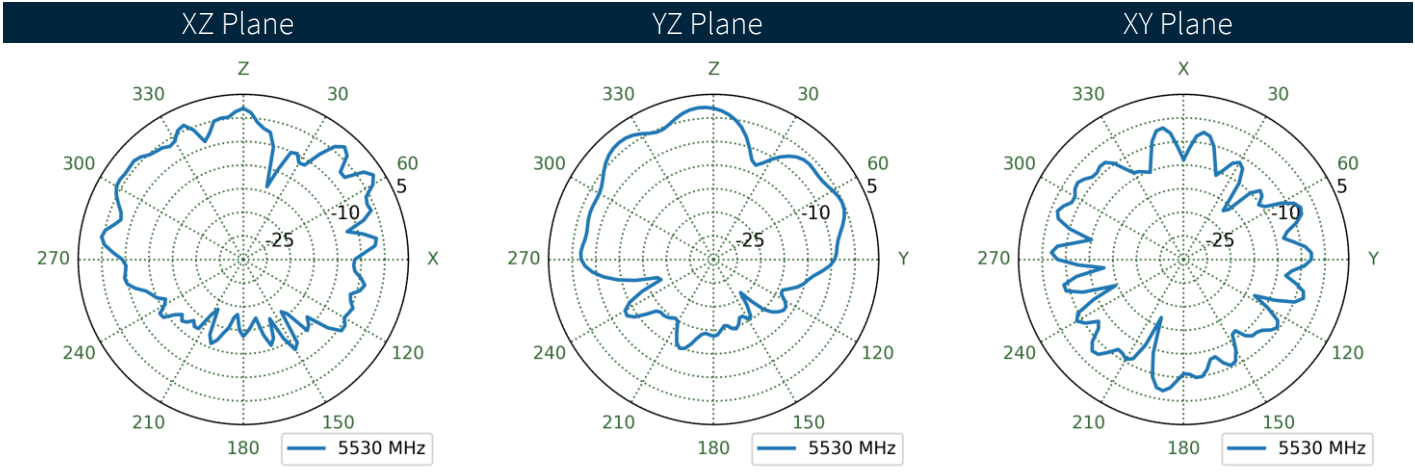
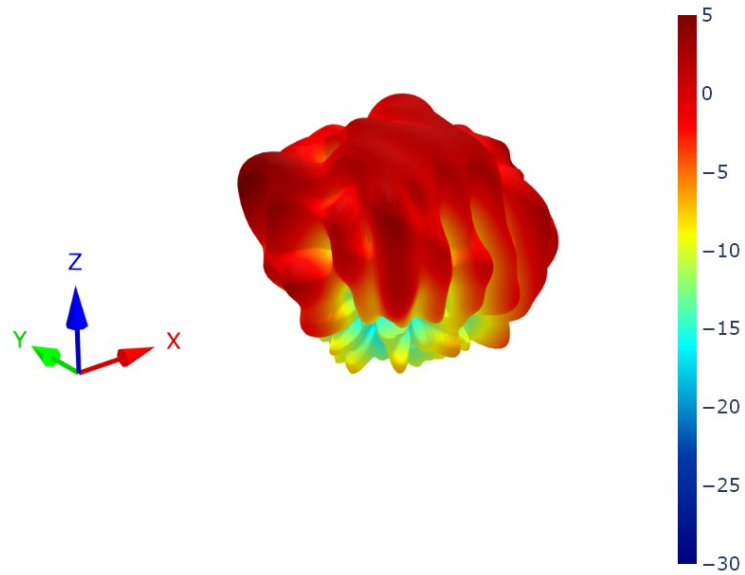

8.101 4G-5G 2 Patterns at 5530 MHz

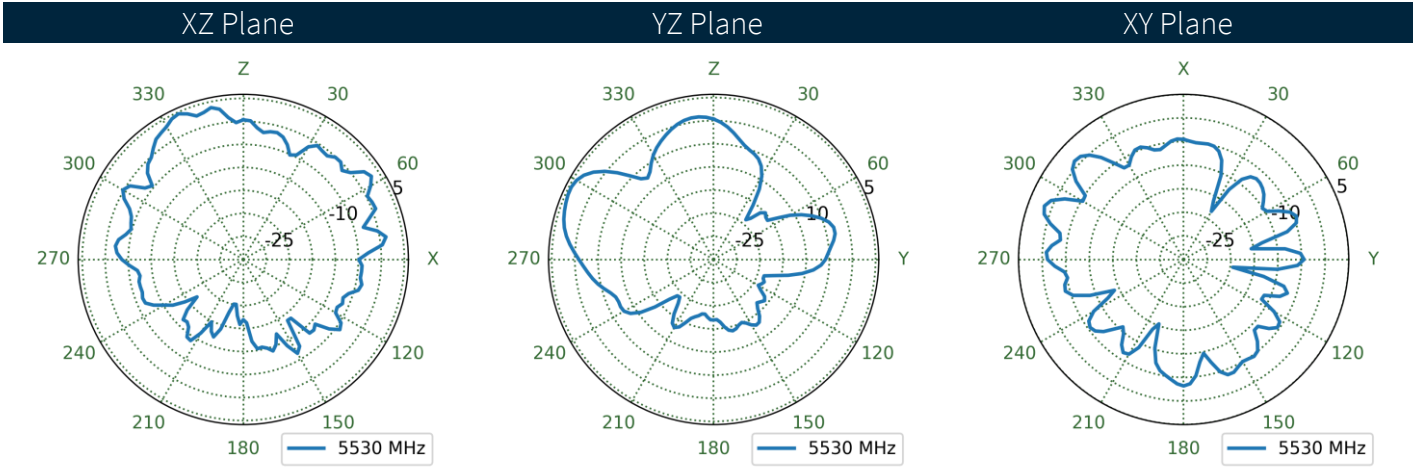
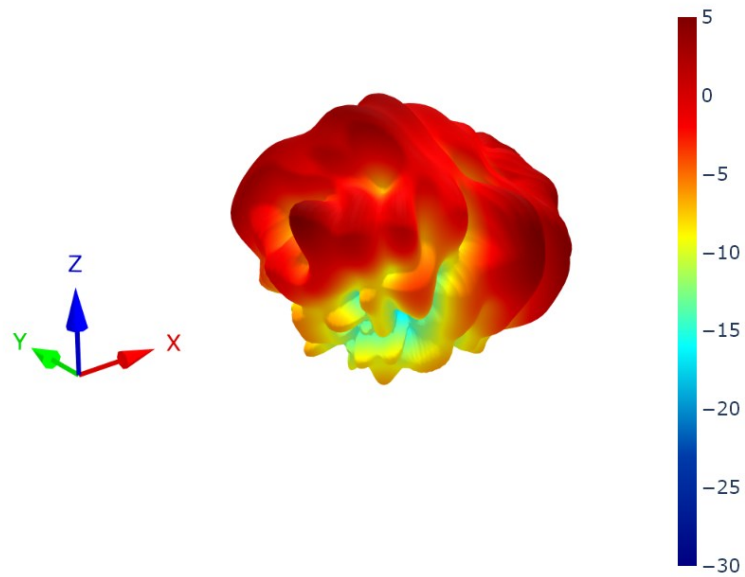

8.102 4G-5G 3 Patterns at 5530 MHz

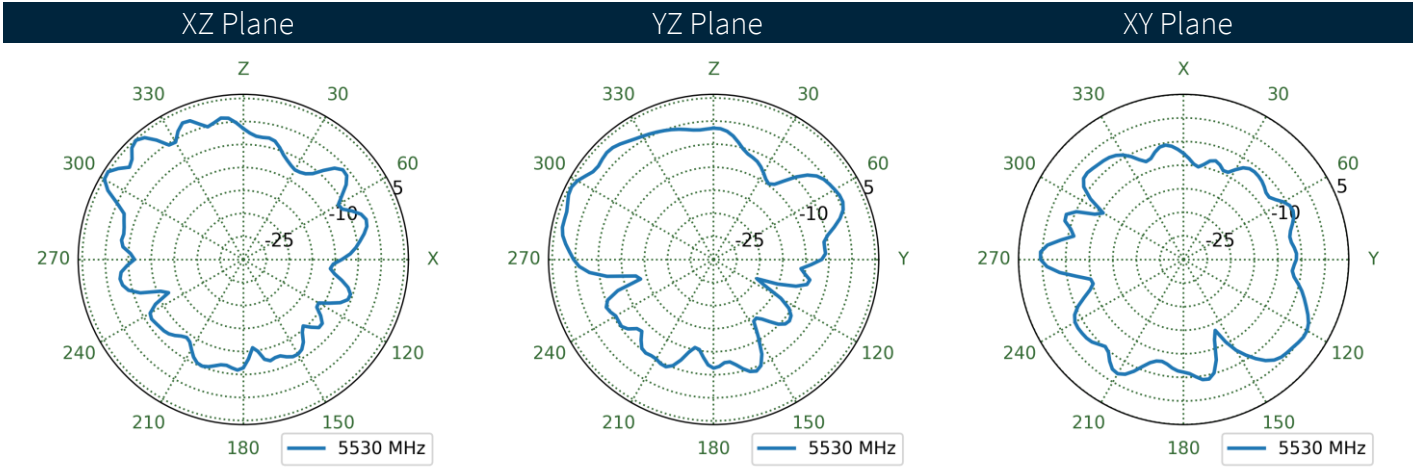
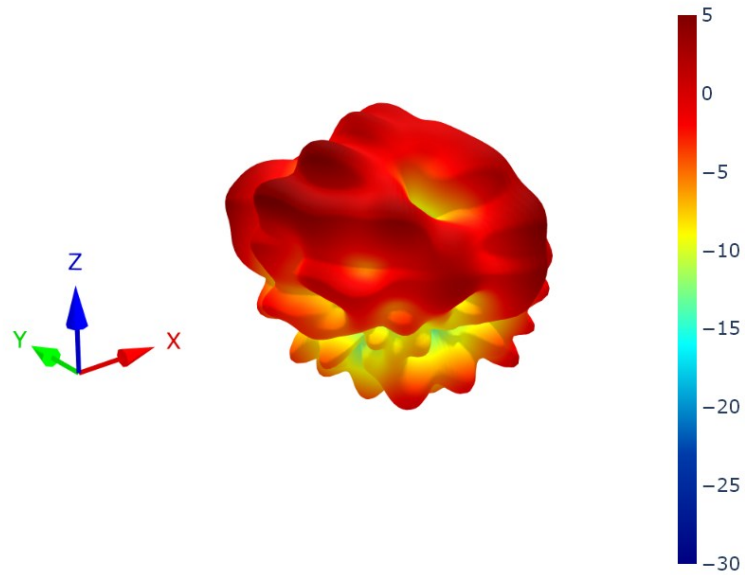

8.103 4G-5G 4 Patterns at 5530 MHz

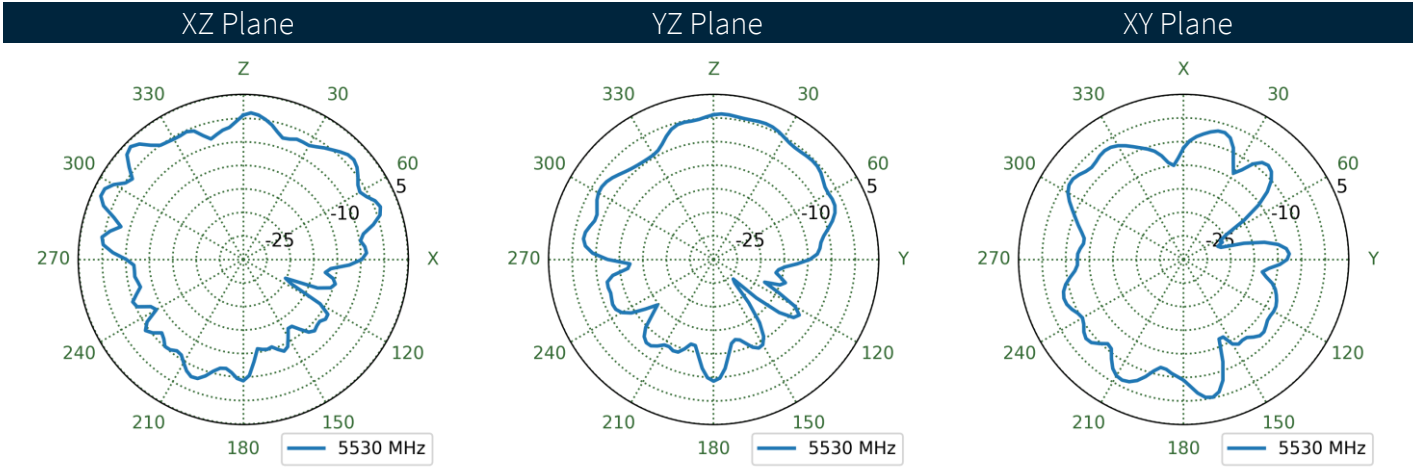
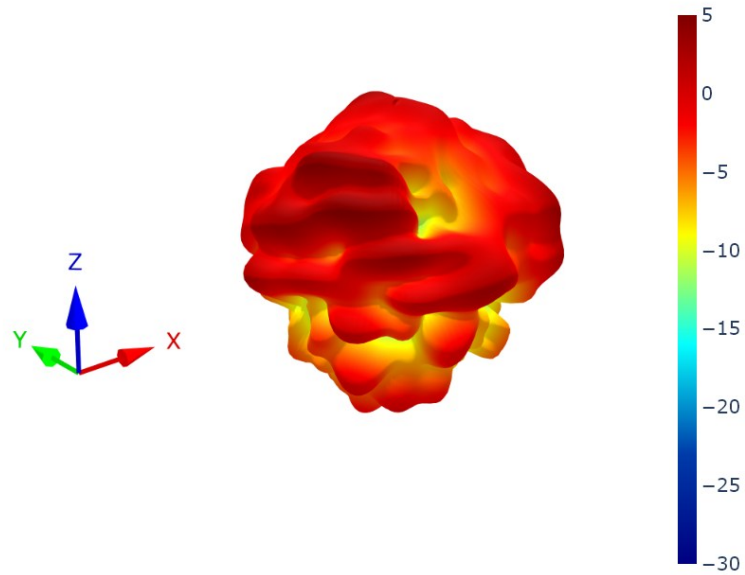

8.104 4G-5G 5 Patterns at 5530 MHz

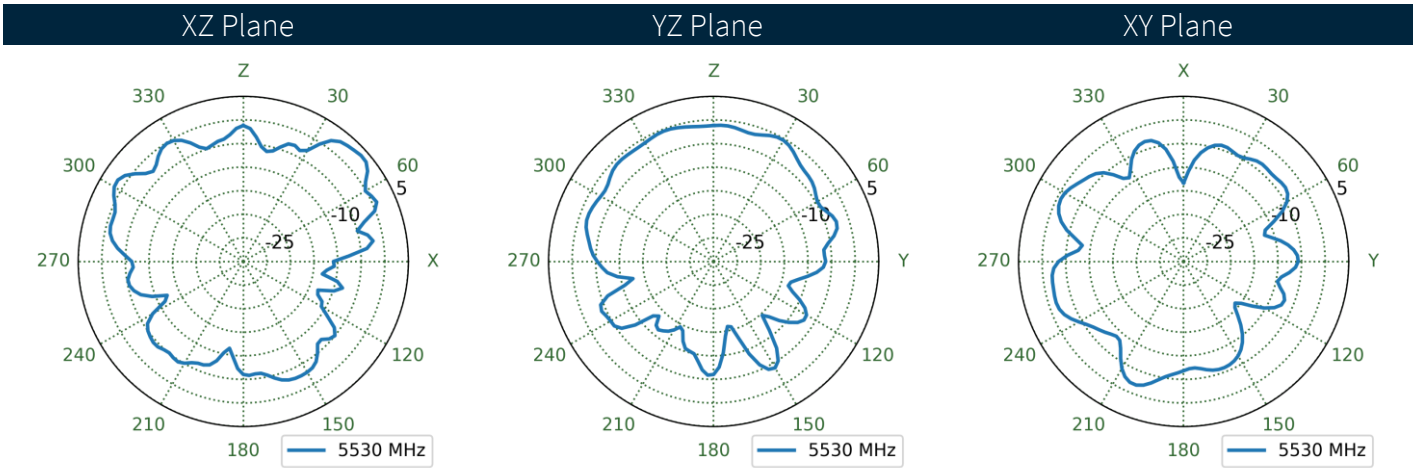
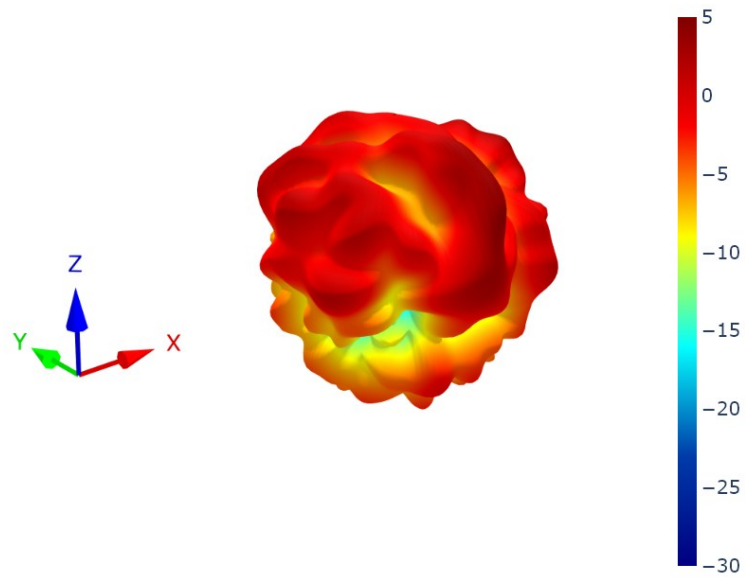

8.105 4G-5G 6 Patterns at 5530 MHz

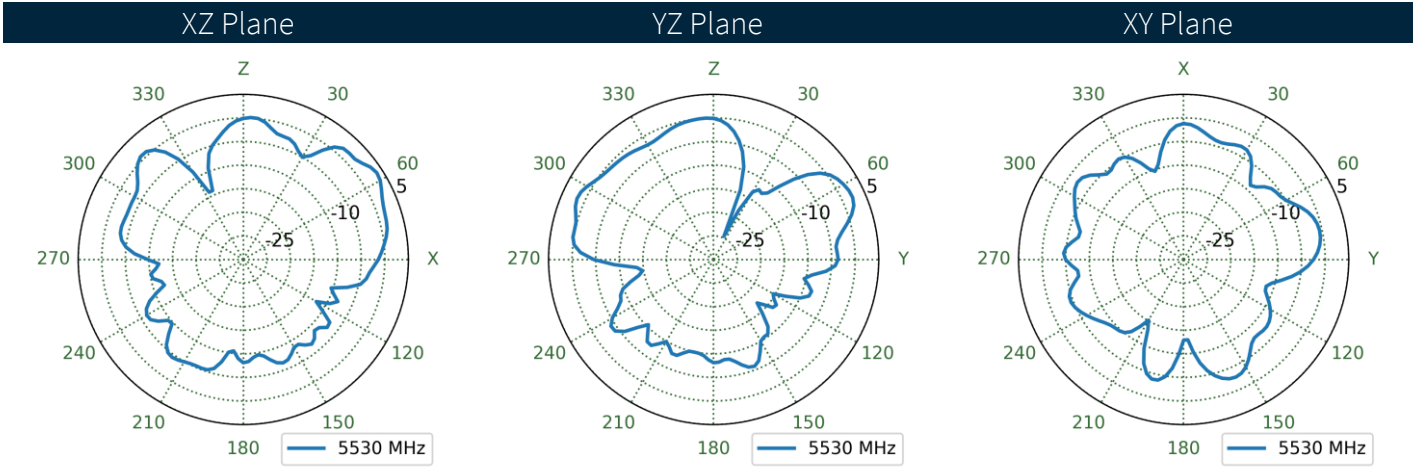
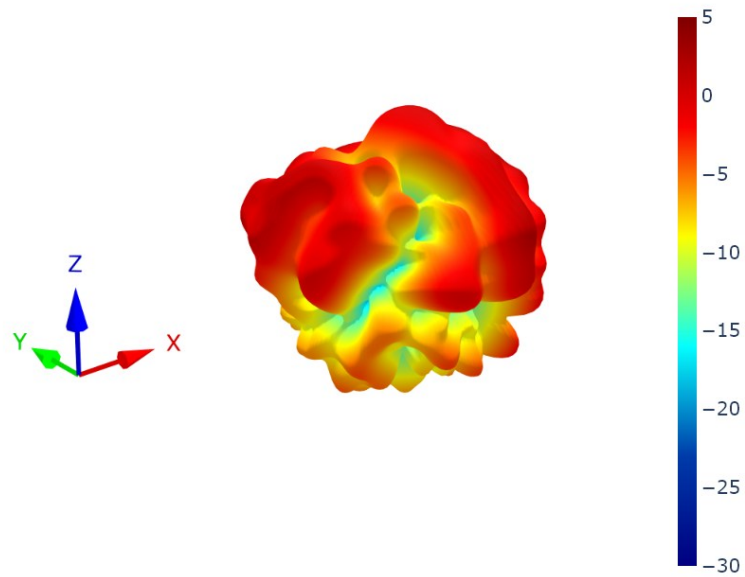

8.106 4G-5G 7 Patterns at 5530 MHz

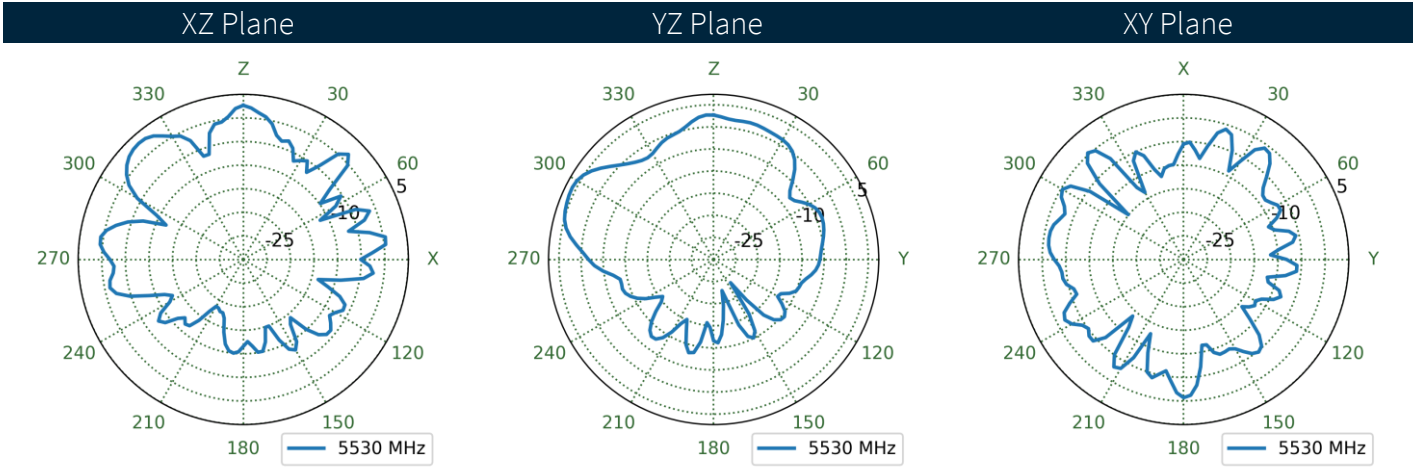
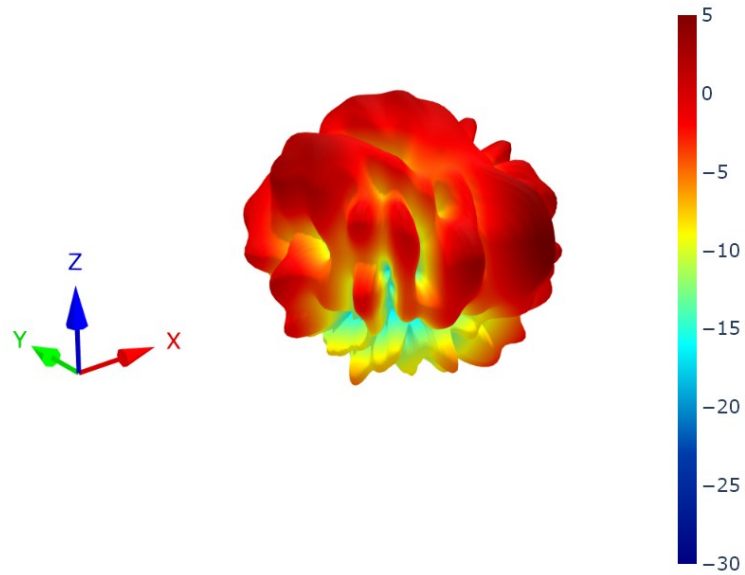

8.107 4G-5G 8 Patterns at 5530 MHz

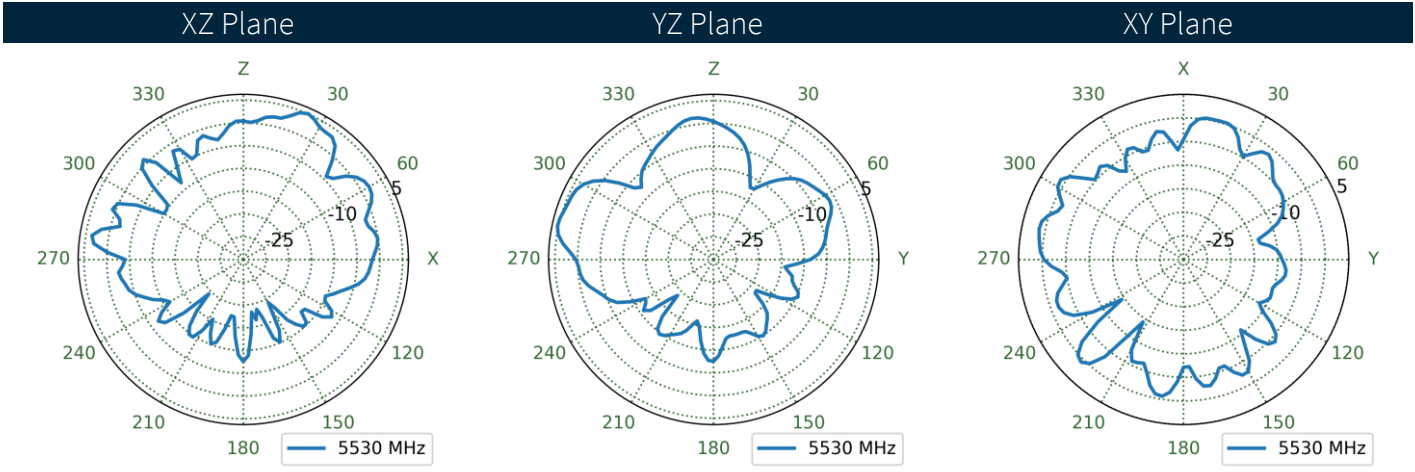
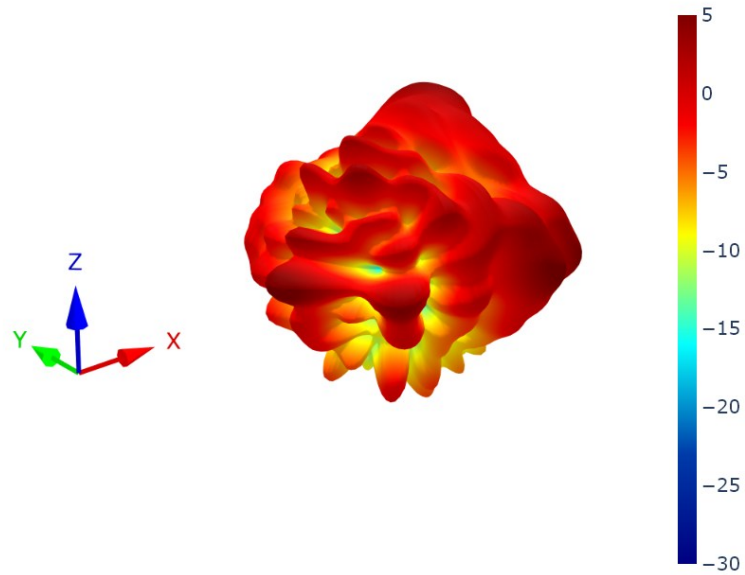

8.108 Wi-Fi1 Patterns at 2450 MHz

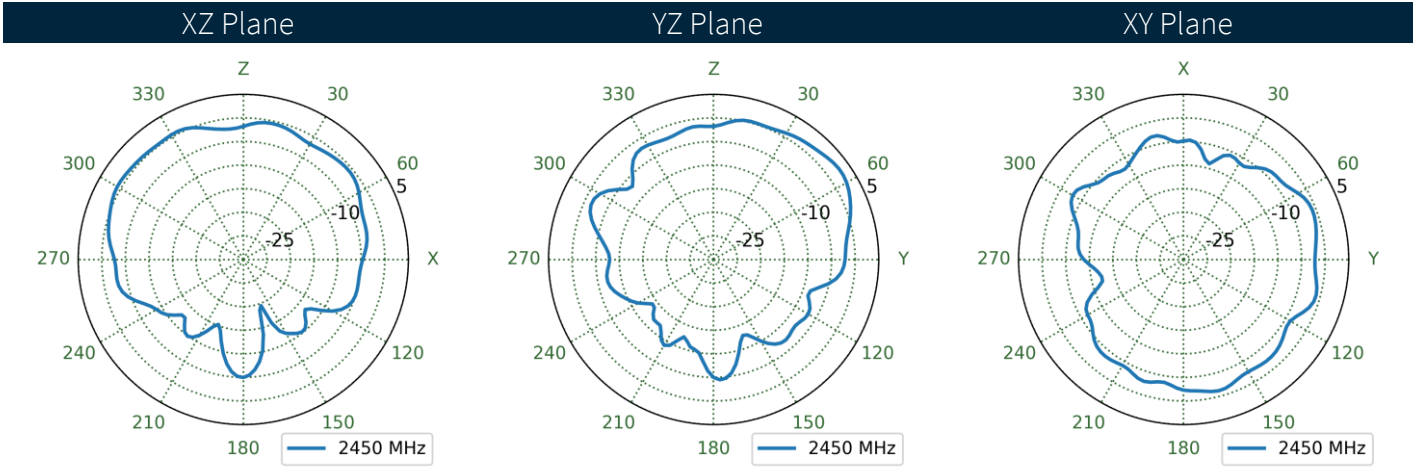
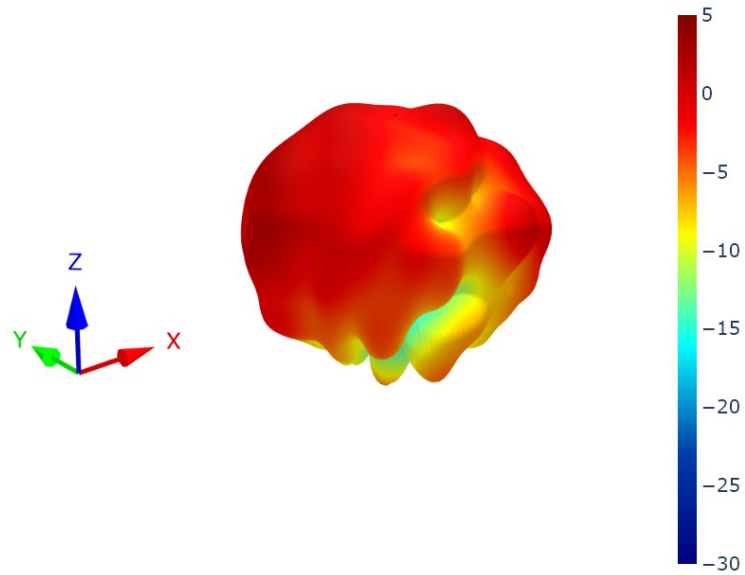

8.109 Wi-Fi2 Patterns at 2450 MHz

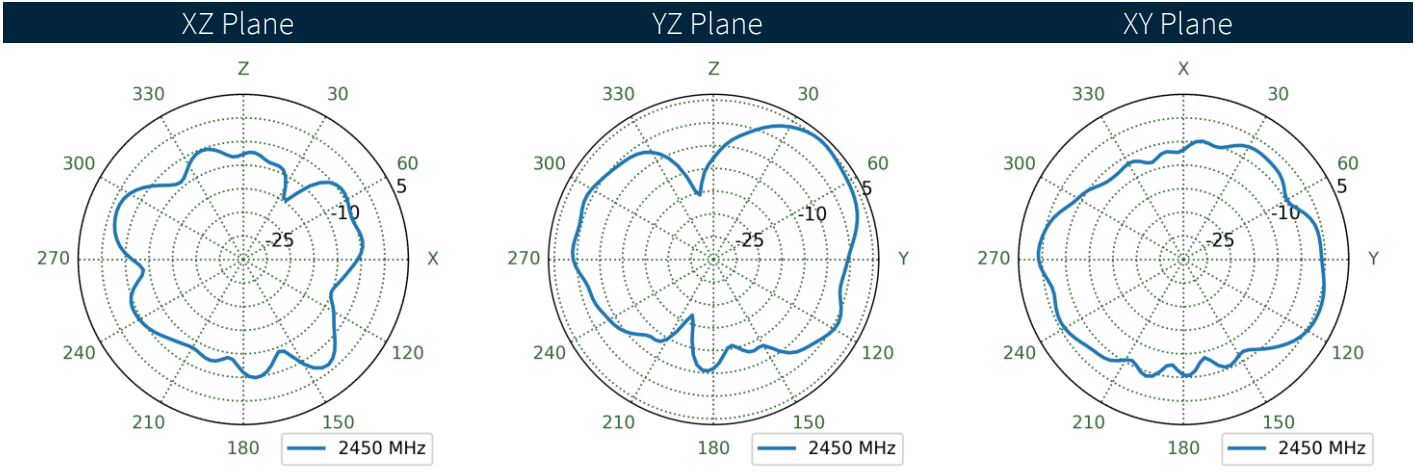
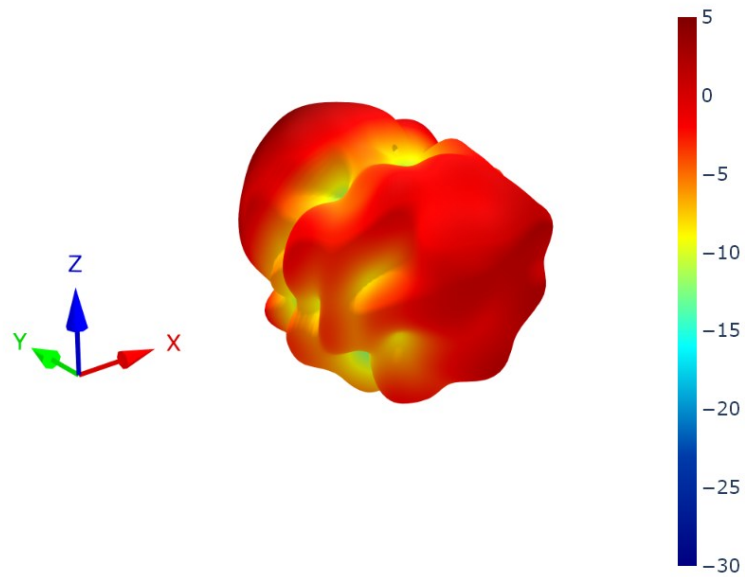

8.110 Wi-Fi3 Patterns at 2450 MHz

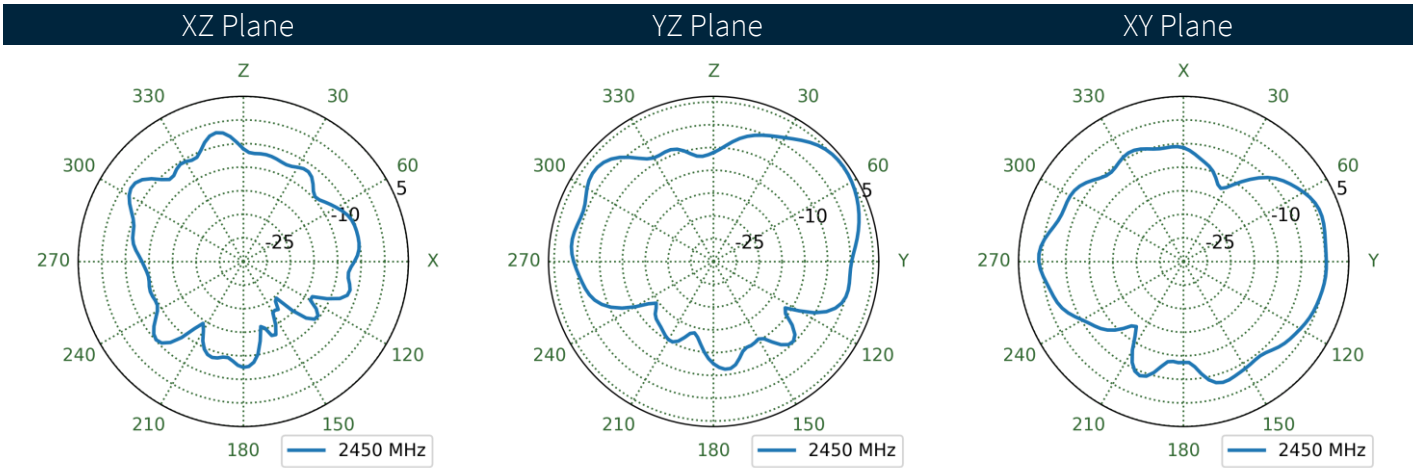
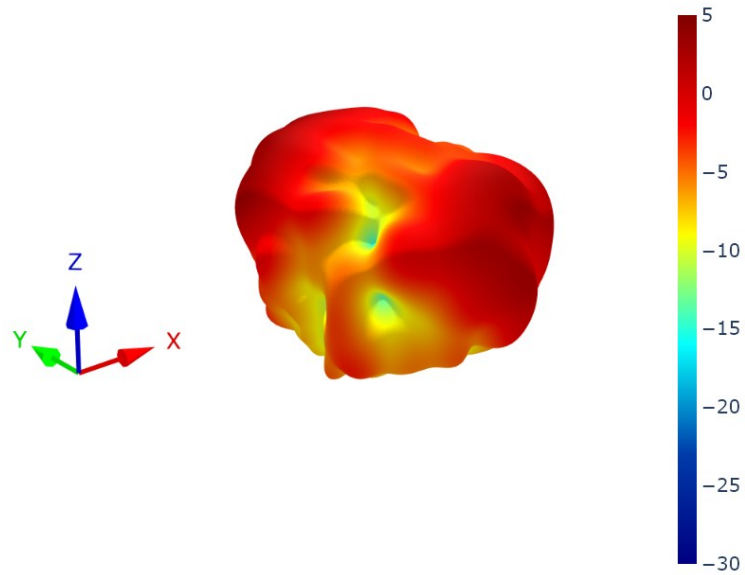

8.111 Wi-Fi1 Patterns at 5490 MHz

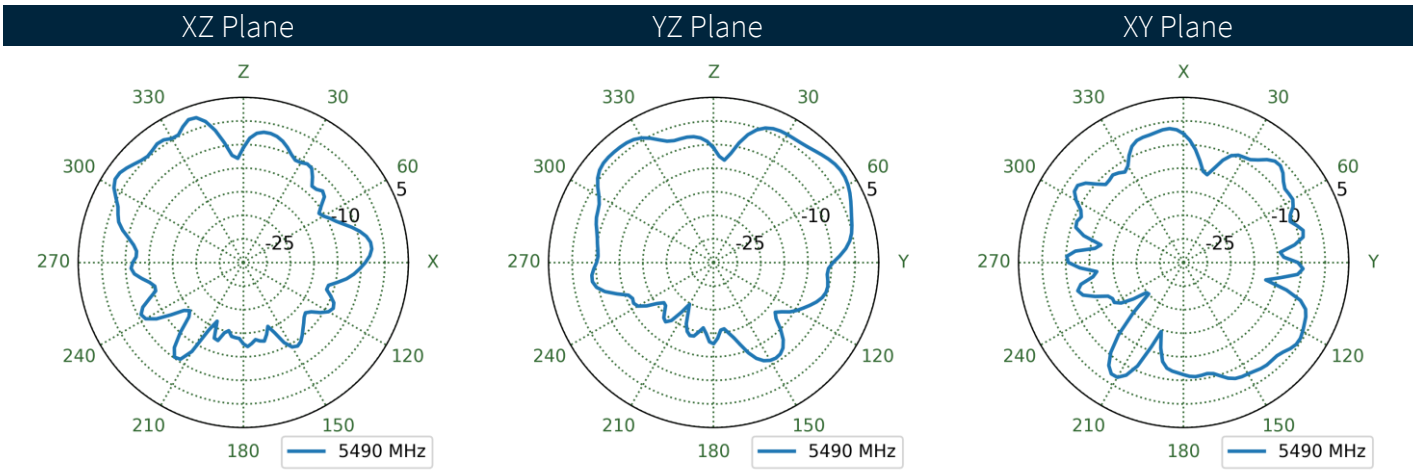
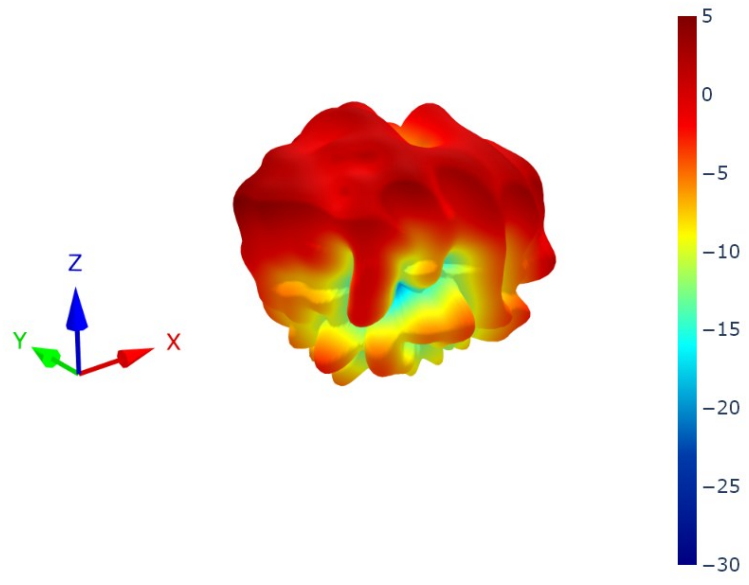

8.112 Wi-Fi2 Patterns at 5490 MHz

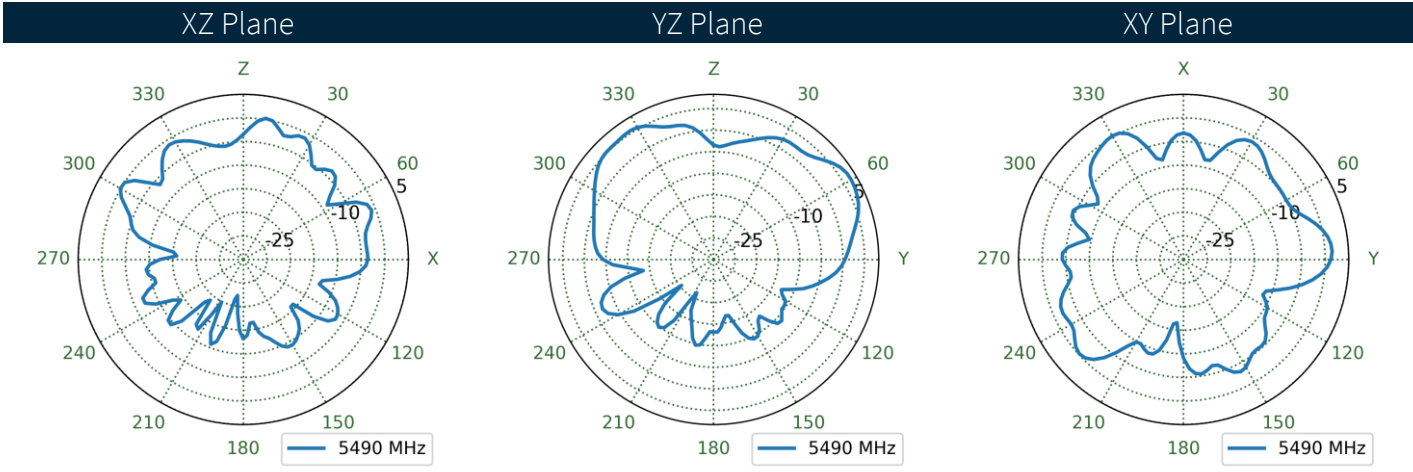
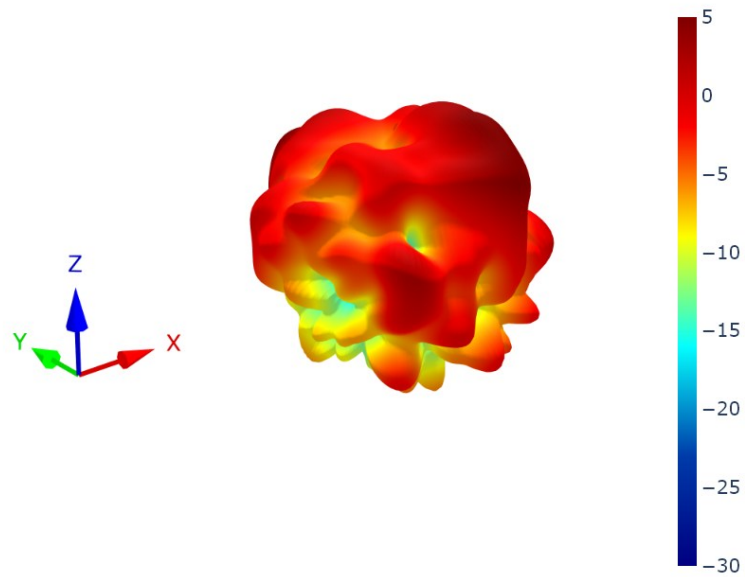

8.113 Wi-Fi3 Patterns at 5490 MHz

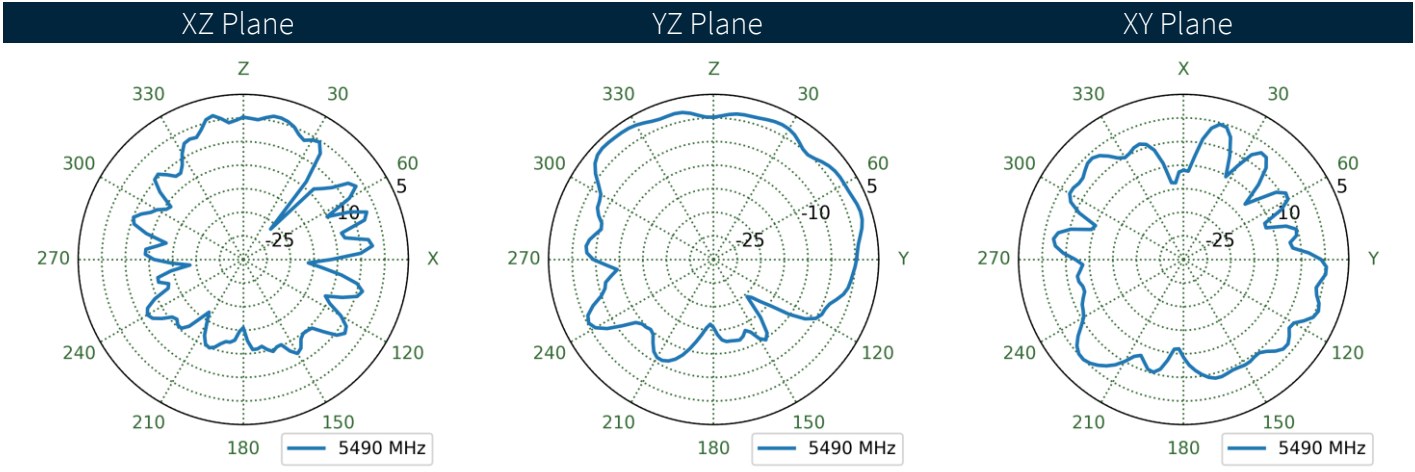
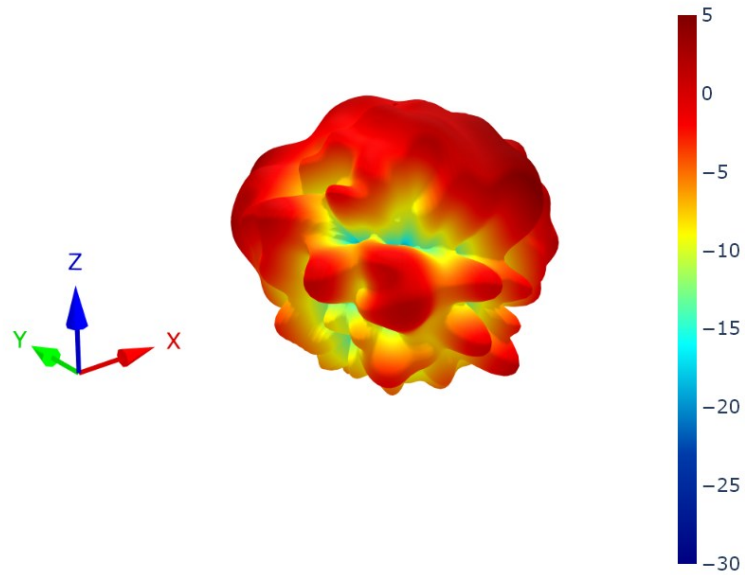

8.114 Wi-Fi1 Patterns at 6525 MHz

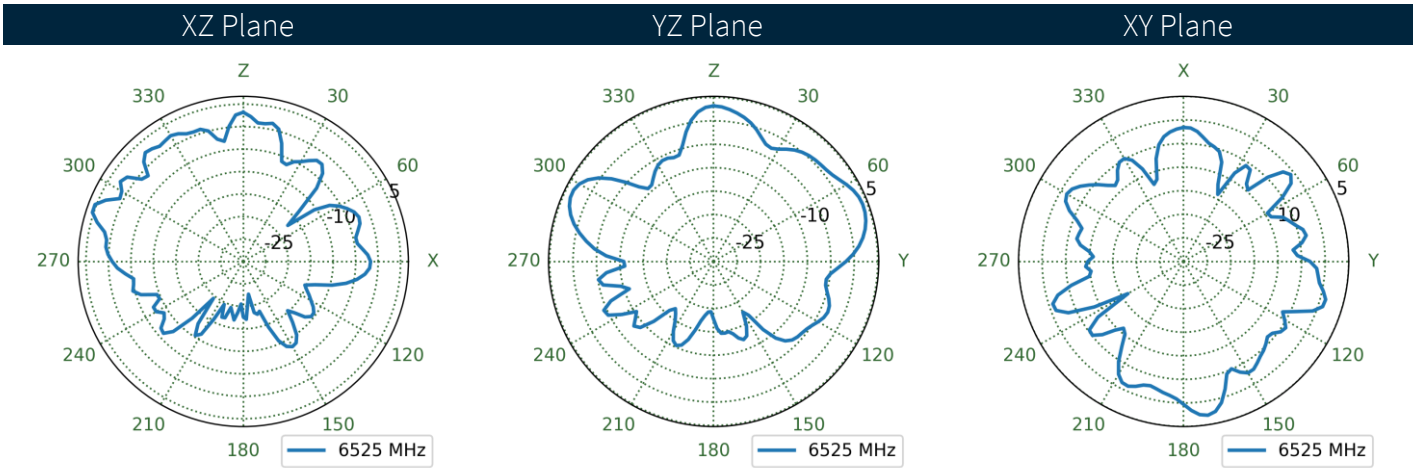
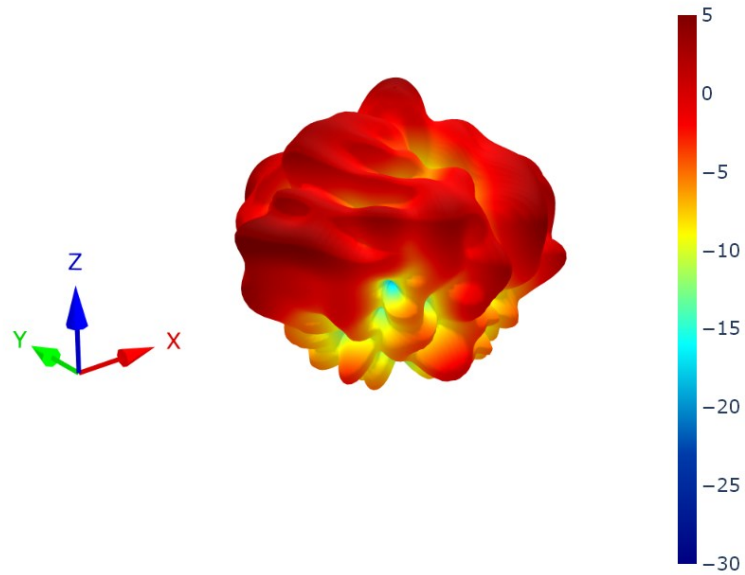

8.115 Wi-Fi2 Patterns at 6525 MHz

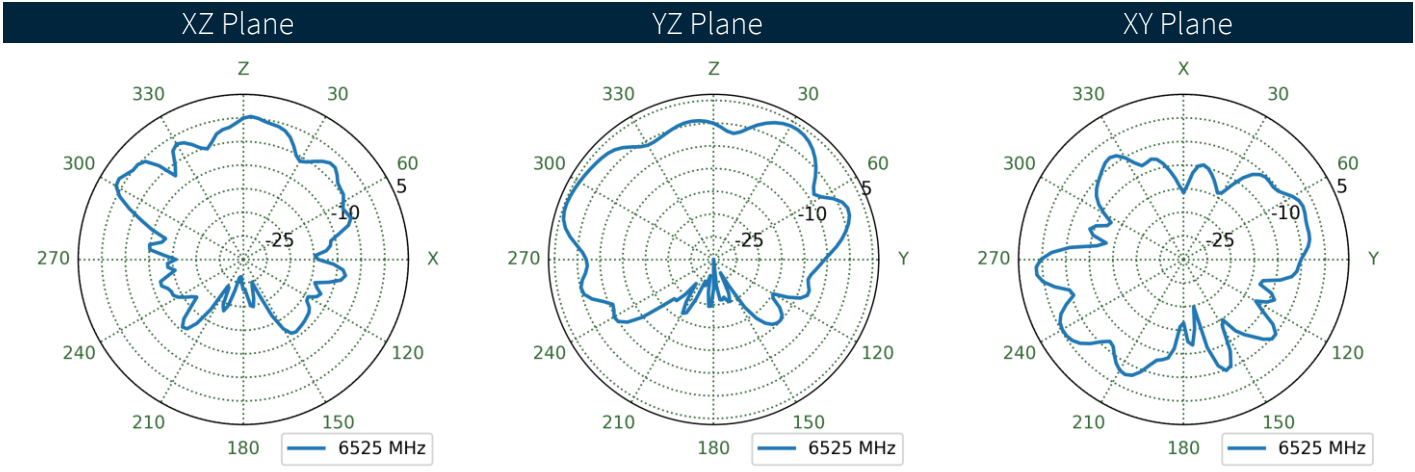
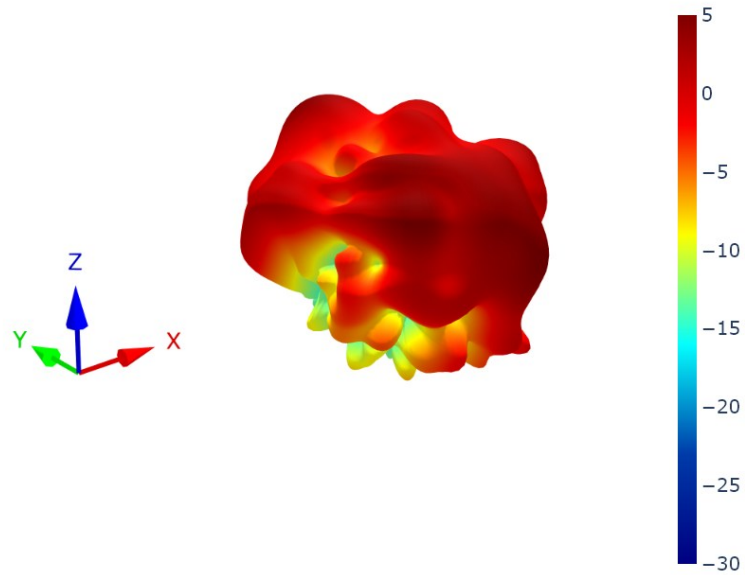

8.116 Wi-Fi3 Patterns at 6525 MHz

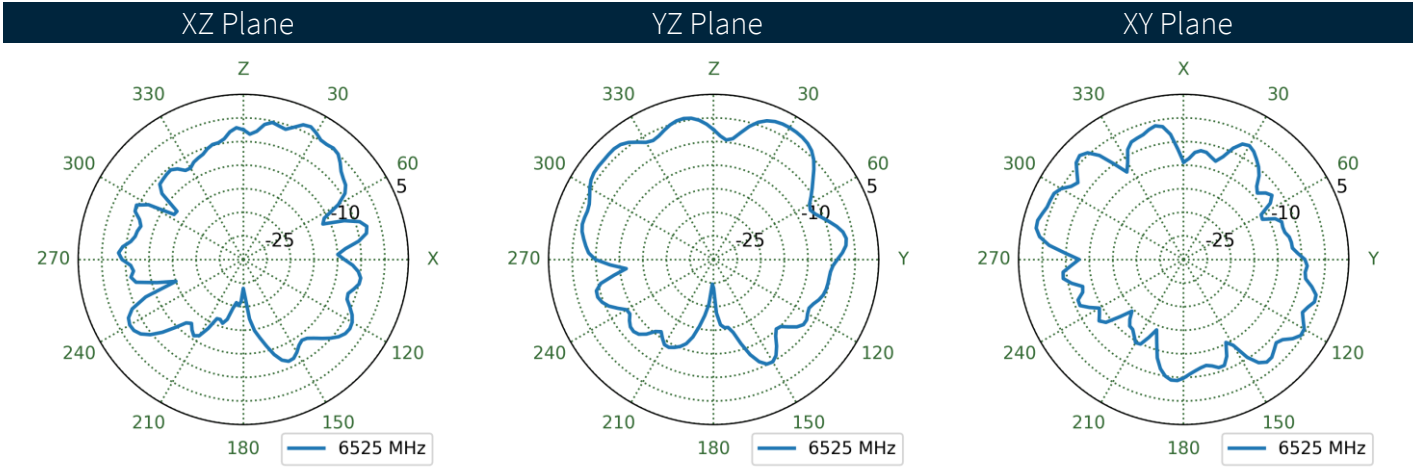
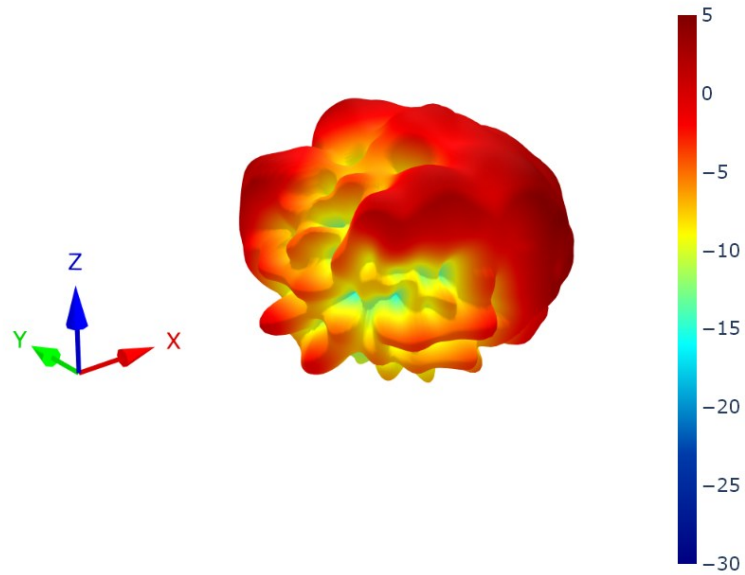

Changelog for the datasheet

SPE-24-8-306 - MAX1012.A.001

Revision: A (Original First Release)

Date: 2024-12-17

Notes: Initial Release

Author: Gary West

Previous Revisions



www.taoglas.com



X-ON Electronics

Largest Supplier of Electrical and Electronic Components

Click to view similar products for [Antennas](#) category:

Click to view products by [Taoglas](#) manufacturer:

Other Similar products are found below :

[930-033-R](#) [EXE902SM](#) [108-00014-50](#) [66089-2406](#) [A09-F8NF-M](#) [A09-F5NF-M](#) [RGFRA1903041A1T](#) [W1049B090](#) [TRABT1560](#)
[WTL2449CQ1-FRSMM](#) [CPL9C](#) [CB27S](#) [0600-00060](#) [Y4503](#) [PAL90209H-FNF](#) [GD53-25](#) [MAF94051](#) [S9025PLSMF](#) [QWFTB120](#)
[MAF94300](#) [FG4403](#) [BB1442NR](#) [GPSCPMM00](#) [ANTDOM-05-01-WPM](#) [ANT-WP868SMA-Y](#) [EXW30BNX](#) [S4908WBFNM](#) [B4305CN](#)
[C27](#) [C27S](#) [CBNC58](#) [EXH160MXI](#) [EXH160SFK](#) [EXC902SM](#) [CB27](#) [ABFT](#) [BB4502NR](#) [B4502N](#) [S4908WBFNF](#) [NMOQ88C](#) [NMOQB](#)
[NMOQC](#) [ANT-GSMGPSPUKS](#) [60210](#) [60140](#) [ANT-8WPIG-UFL](#) [ANT-GPSPUKS](#) [A21H0](#) [29000863](#) [29000848](#)