

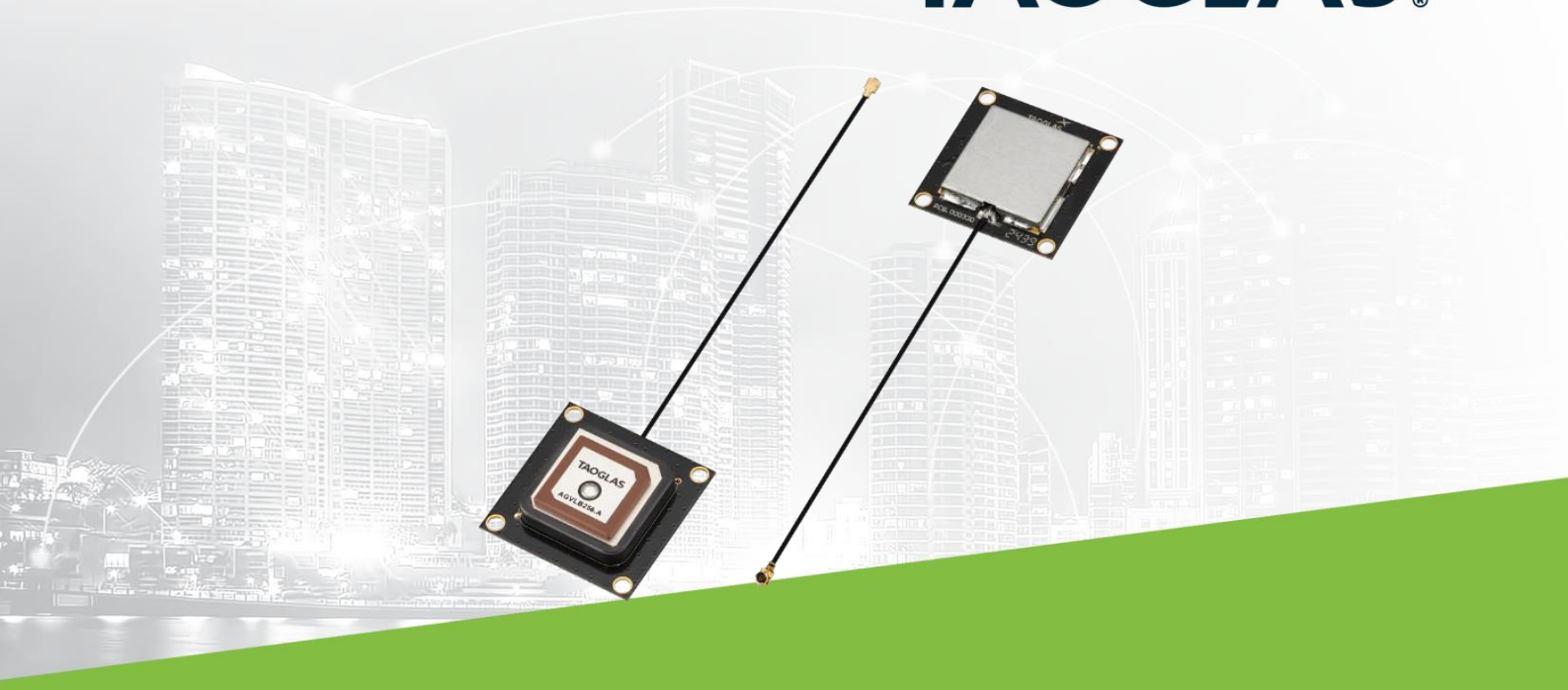

TAOGLAS®



Datasheet

Part No:
AGVLB256.A.07.0100A0

Description

GPS/GLONASS/BeiDou/IRNSS L1 + L5 Stacked Active Patch 2 Stage LNA Antenna,
100mm 1.13 Micro Coax IPEX MHFI

Features:

Single Feed Stacked Patch Assembly
Covering Bands
– GPS L1 & L5
– BeiDou B1I
– GLONASS G1
Tuned for Centre Positioning on a 70x70mm Ground Plane
Dual Stage LNA
Dimensions: 25x25x10mm
Cable: 100mm of \varnothing 1.13mm
Connector: I-PEX MHF® I (U.FL Compatible)
RoHS & REACH Compliant

1.	Introduction	3
2.	Specification	4
3.	Mechanical Drawing	7
4.	Packaging	8
5.	Antenna Characteristics	9
6.	Radiation Patterns	13
7.	LNA Characteristics	22
<hr/>		
	Changelog	26

Taoglas makes no warranties based on the accuracy or completeness of the contents of this document and reserves the right to make changes to specifications and product descriptions at any time without notice. Taoglas reserves all rights to this document and the information contained herein. Reproduction, use or disclosure to third parties without express permission is strictly prohibited.

Ireland & USA
ISO 9001:2015
Certified



Taiwan
ISO 9001:2015
Certified



1. Introduction



The Taoglas AGVLB256.A is a multi-band GPS, GLONASS, BeiDou/Compass and IRNSS, high performance GPS L1 / L5 & BeiDou B1 Active Stacked Patch Antenna for high precision GPS and BeiDou accuracy and fast positioning. It utilizes a 25*25*10mm advanced dual stacked ceramic patch antenna with optimized gain for GPS L1/L5, Galileo, IRNSS and BeiDou bands, allowing for better navigation accuracy.

The AGVLB256.A has been designed for in-device mounting with a small size of just 25*25*10mm, it can fit in some of the most compact devices. This compact antenna exhibits excellent radiation patterns on both GPS L1/L5 bands and with a low noise figure to preserve signal quality helps minimize time to first fix. It also features excellent out-of-band rejection to prevent out-of-band signals from overdriving or damaging its LNAs.

Typical Applications Include:

- Autonomous Vehicles
- Precision Agriculture
- Surveying & Mapping Equipment
- Telematics & Fleet Management
- Industrial & Construction Machinery
- Marine & Navigation Systems

The cable and connector are fully customizable, contact your regional Taoglas customer support team to request these services or additional support to integrate and test this antenna's performance in your device.

2. Specification

GNSS Frequency Bands					
GPS	L1 1575.42 MHz	L2 1227.6 MHz	L5 1176.45 MHz		
	■	□	■		
GLONASS	G1 1602 MHz	G2 1248 MHz	G3 1207 MHz		
	■	□	□		
Galileo	E1 1575.24 MHz	E5a 1176.45 MHz	E5b 1201.5 MHz	E6 1278.75 MHz	
	■	■	□	□	
BeiDou	B1C 1575.42 MHz	B1I 1561 MHz	B2a 1176.45 MHz	B2b 1207.14 MHz	B3 1268.52 MHz
	■	■	■	□	□
L-Band	L-Band 1542 MHz				
	□				
QZSS (Regional)	L1 1575.42 MHz	L2C 1227.6 MHz	L5 1176.45 MHz	L6 1278.75e6	
	■	□	■	□	
IRNSS (Regional)	L5 1176.45 MHz				
	■				
SBAS	L1/E1/B1 1575.42 MHz	L5/B2a/E5a 1176.45 MHz	G1 1602 MHz	G2 1248 MHz	G3 1207 MHz
	■	■	■	□	□

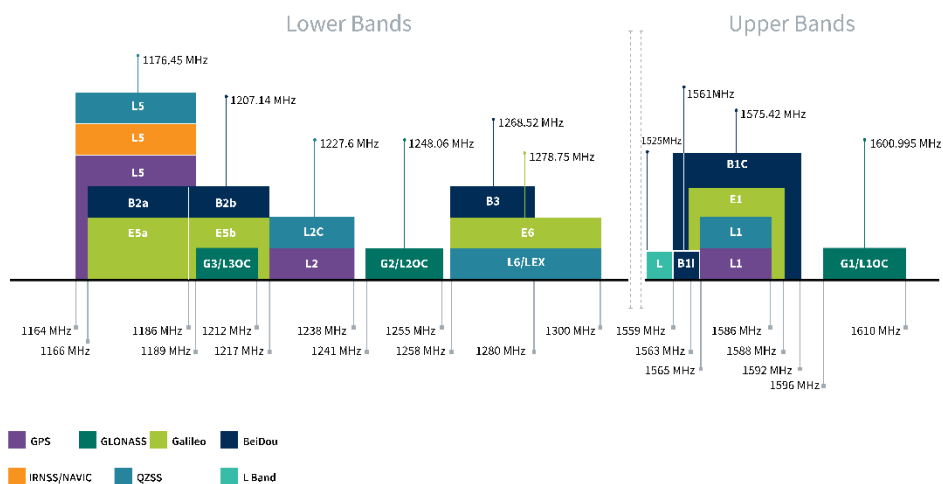

GNSS Bands and Constellations

GNSS Electrical					
Frequency (MHz)	Test Set-up	1176.45	1561	1575.42	1603
VSWR	70x70mm Ground Plane	2.5:1	2.5:1	3:1	2:1
	Free Space	3.5:1	3:1	5:1	3:1
Efficiency (%)	70x70mm Ground Plane	62.1	56.0	42.2	41.5
	Free Space	39.9	29.4	20.2	27.1
Peak Gain (dBi)	70x70mm Ground Plane	0.58	2.73	1.73	1.67
	Free Space	0.29	-1.26	-3.14	-2.12
Average Gain (dB)	70x70mm Ground Plane	-2.07	-2.52	-3.75	-3.82
	Free Space	-3.99	-5.32	-6.96	-5.68
Polarization	Linear				
Impedance	50 Ω				

LNA and Filter Electrical Properties				
Frequency (MHz)	1176.45	1561	1575.42	1603
Gain(dB)	30.37	29.86	29.55	29.35
Noise Figure(dB)	2.91	2.78	2.92	2.46
Group Delay(ns)	25.30	28.66	25.61	29.83
Out Of Band Rejection (dB)	> 70dB @ 600-1000 MHz; > 60dB @ 1700-6000 MHz			
ESD Protection	Contact: ± 20 kV, Air: ± 25 kV discharge			
Current Consumption (mA)	18			
Input Voltage (V)	+ 1.8 to 5.5			

Mechanical	
Dimensions	25 x 25 x 10mm
Weight	30g
Material	Ceramic
Connector	IPEX.MHFHT
Cable	100mm 1.13 Coaxial Cable

Environmental	
Operation Temperature	-40°C to 85°C
Storage Temperature	-40°C to 85°C
Relative Humidity	Non-condensing 65°C 95% RH

3. Mechanical Drawing

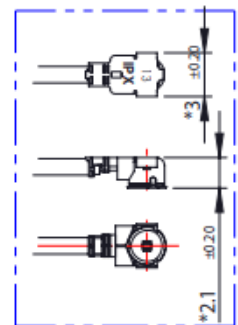
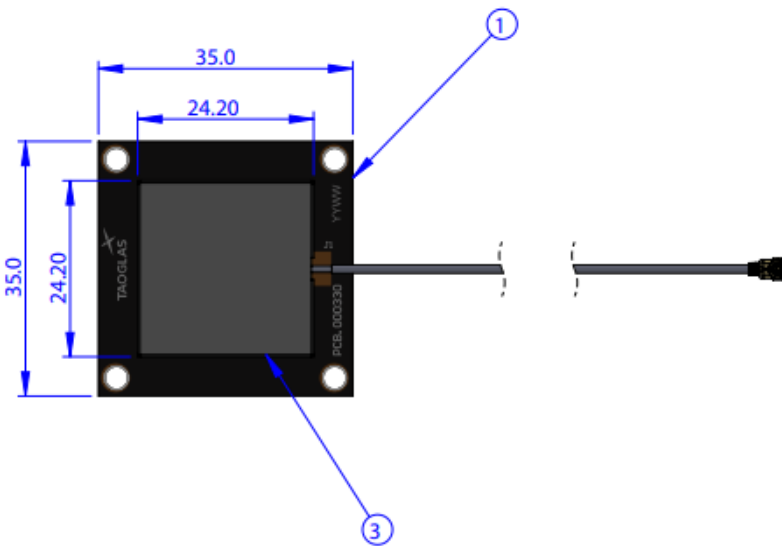
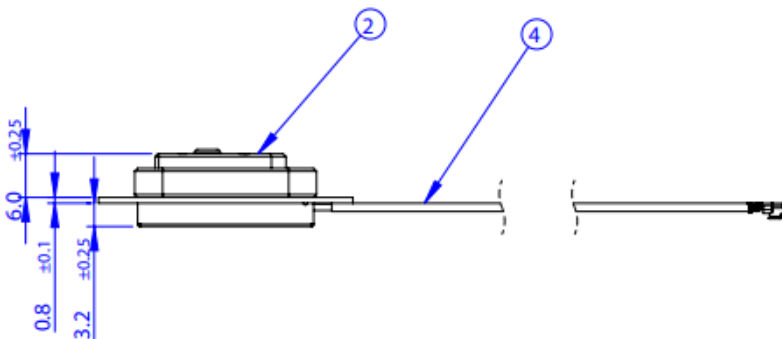
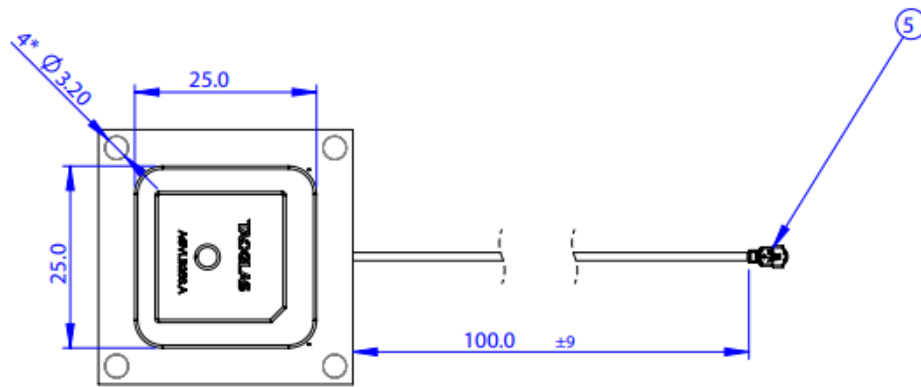

IPEX MHF1
Detail
Scale: 2:1

	Name	Material	Finish	Qty
1	PCB	NP-140	Black	1
2	Patch	Ceramic	Clear	1
3	Shielding Case	SECC	Nature	1
4	1.13 Coaxial cable	FEP	Black	1
5	IPEX.MHF1	Composite	Au Plated	1

4. Packaging

AGVLB256.A.07.0100AO1
1 PCS / Bubble bag



1 PCS / Vacuum bag
1 PCS / 3g Desiccant
Weight (g): 30 ±3%

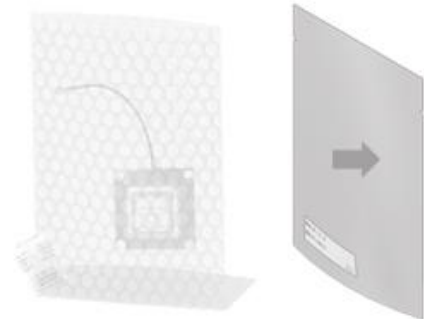

60 PCS / Carton
6 PCS / Fragile sticker
Carton(mm): 390 x 320 x 290
Weight (Kg): 2.5 ±3%
Carton Label



5. Antenna Characteristics

5.1 Test Setup

AUT



Vector Network Analyzer

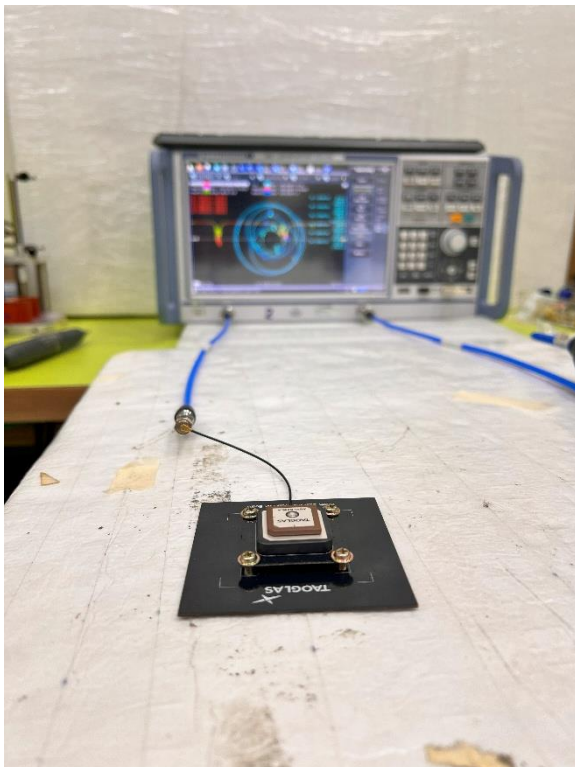

70x70mm Ground Plane

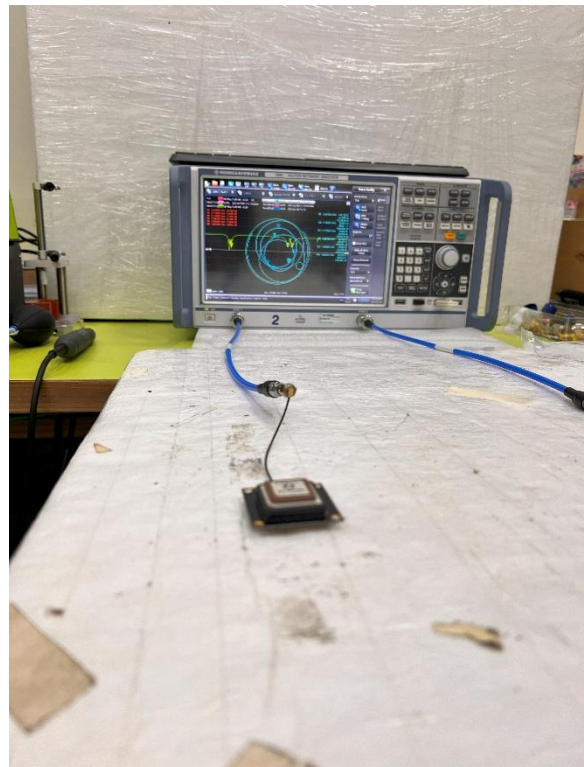

Free Space

5.2 Return Loss

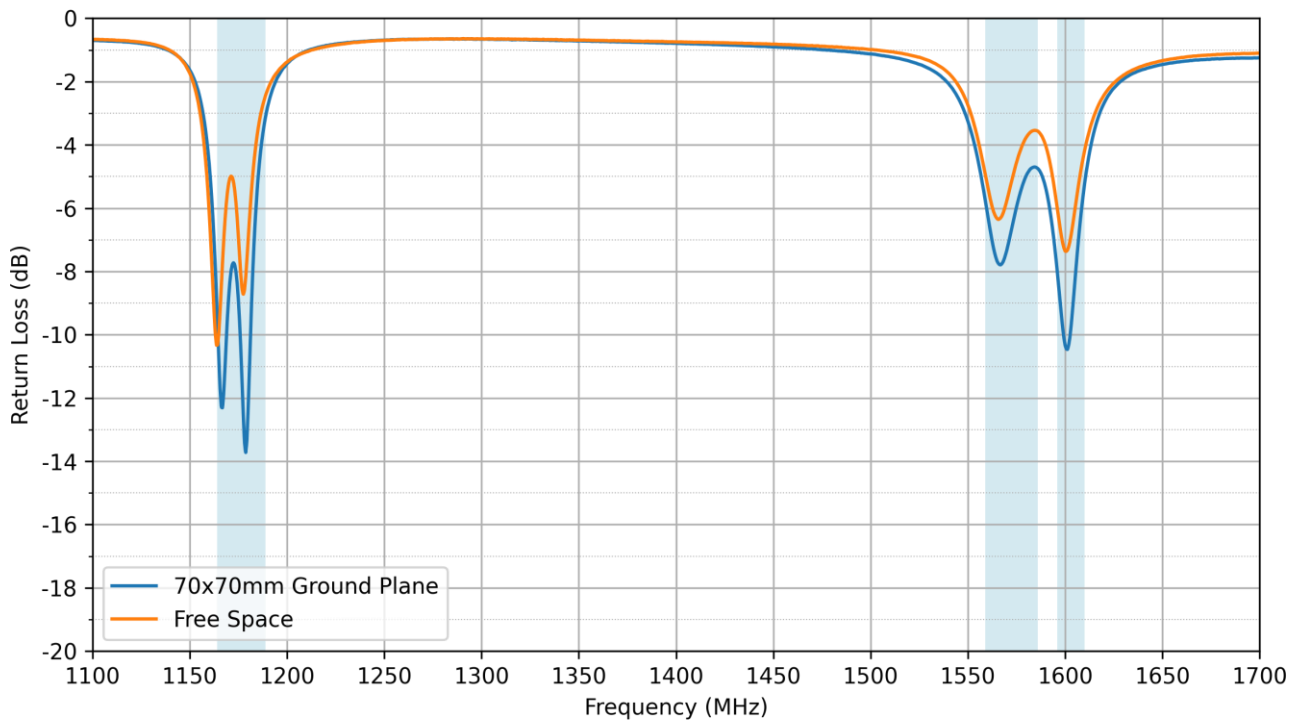

5.3 VSWR

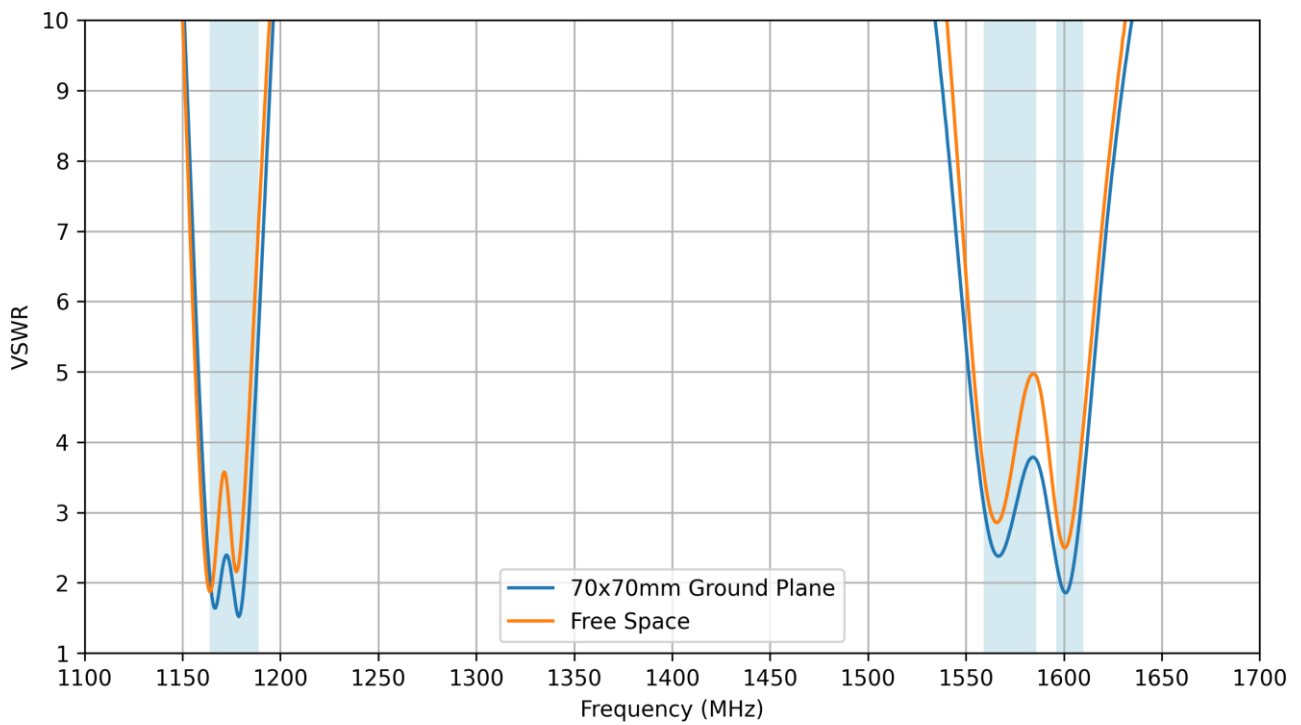

5.4 Efficiency

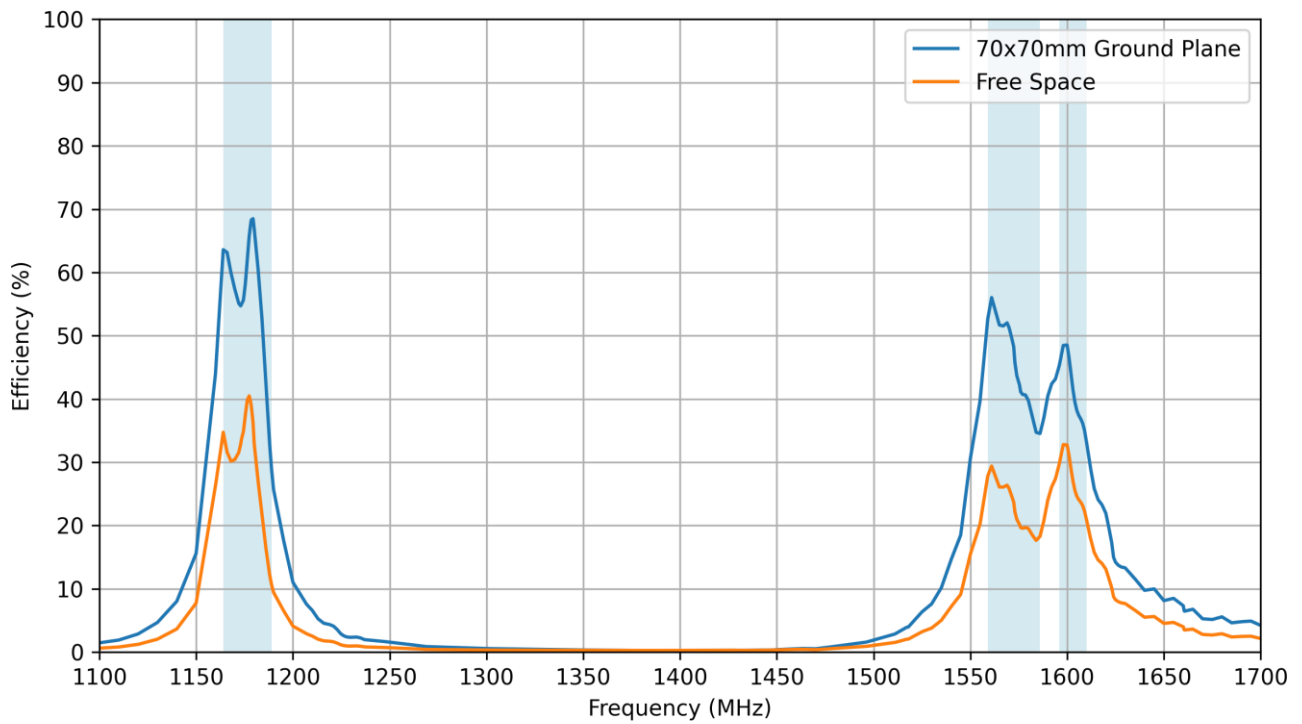

5.5 Average Gain

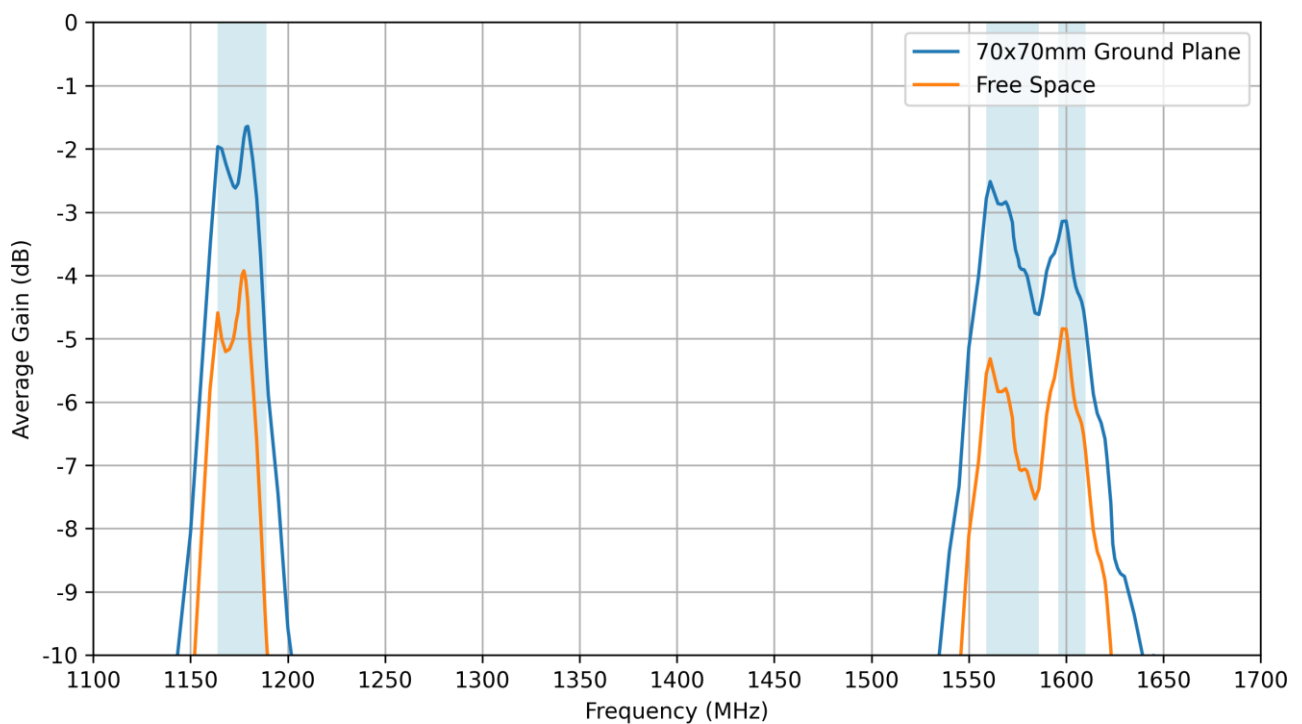

5.6 Peak Gain

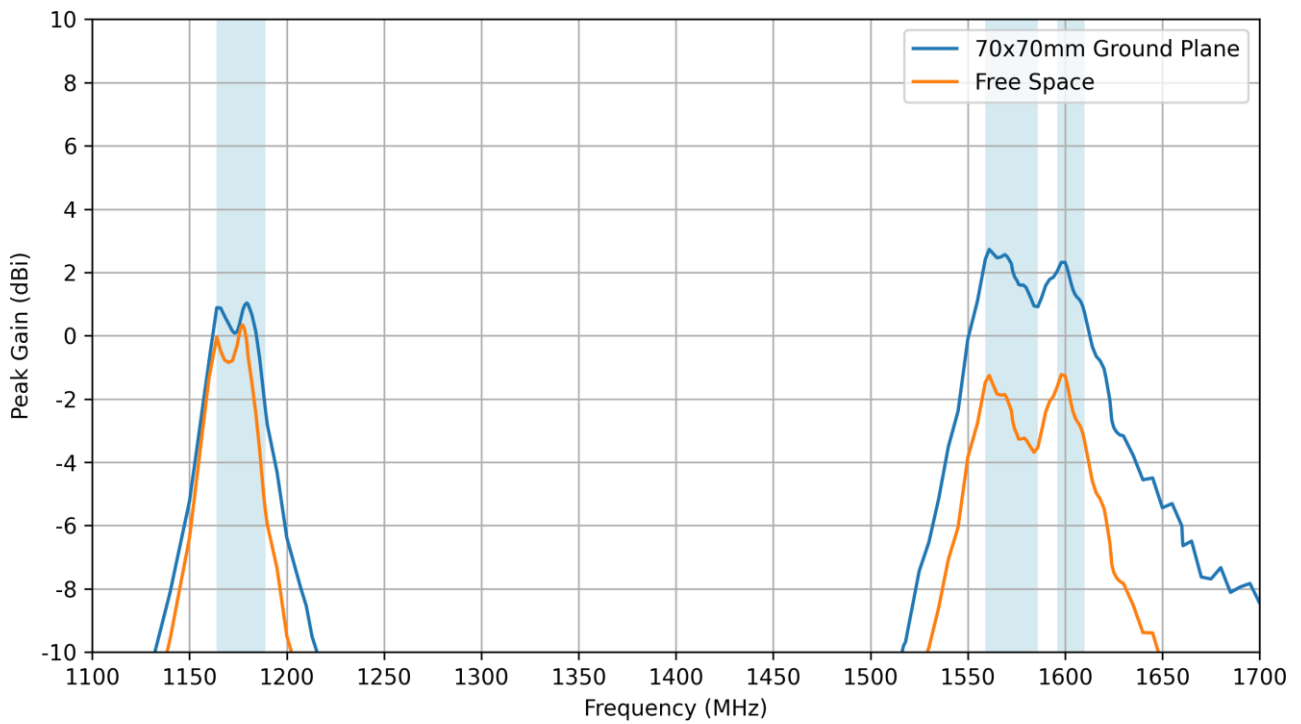

5.7 Axial Ratio

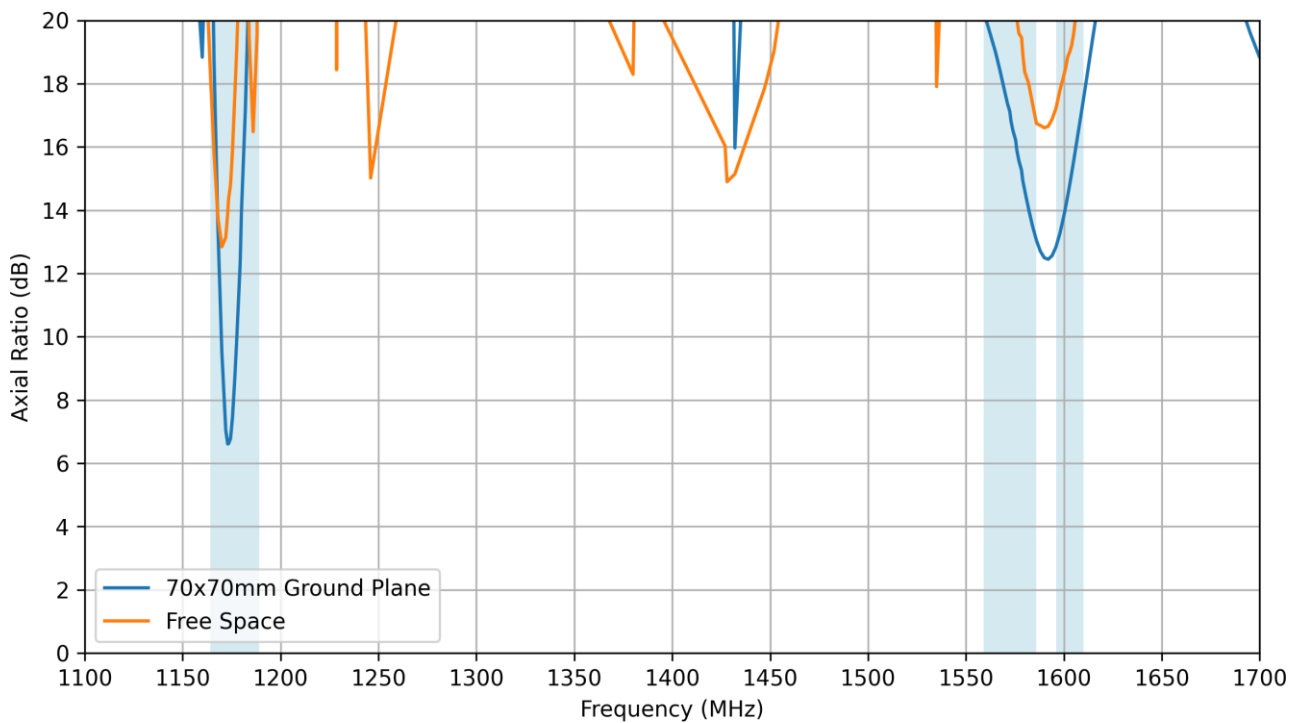

6. Radiation Patterns

6.1 Test Setup

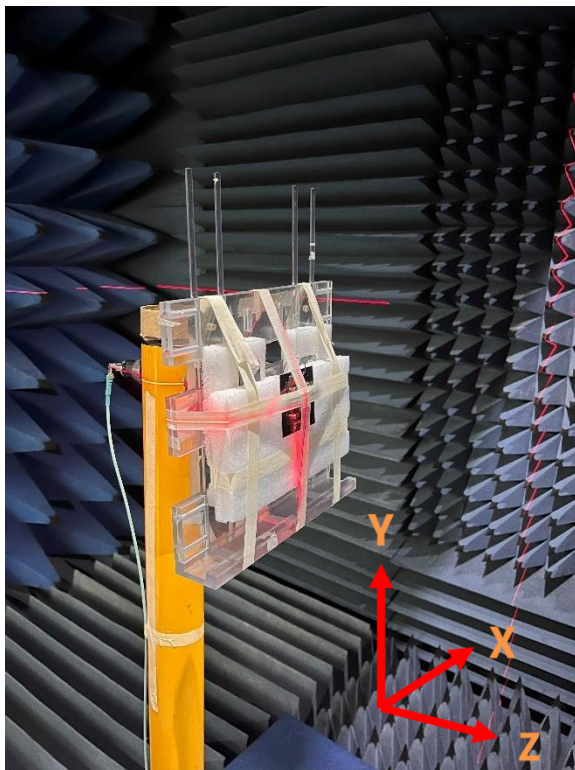
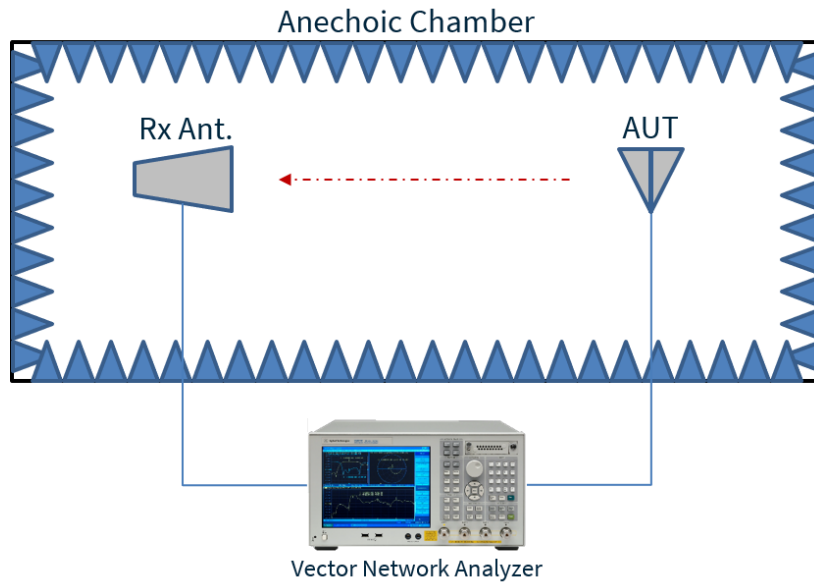

70x70mm Ground Plane

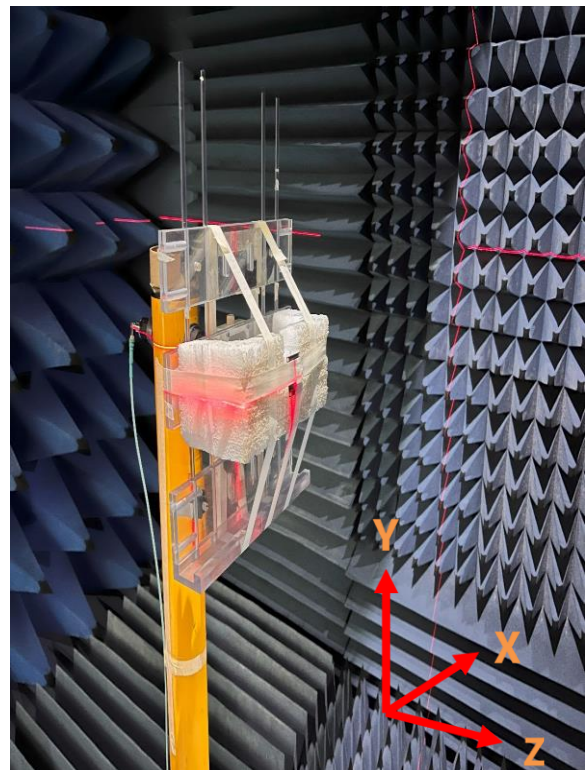

Free Space

6.2 70x70mm Ground Plane Patterns at 1176 MHz

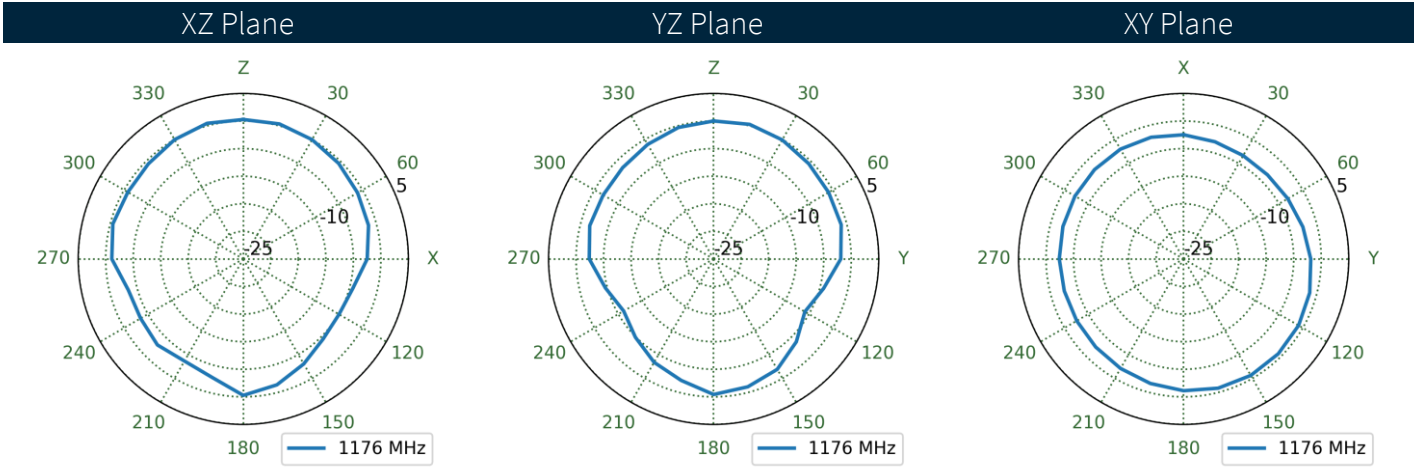
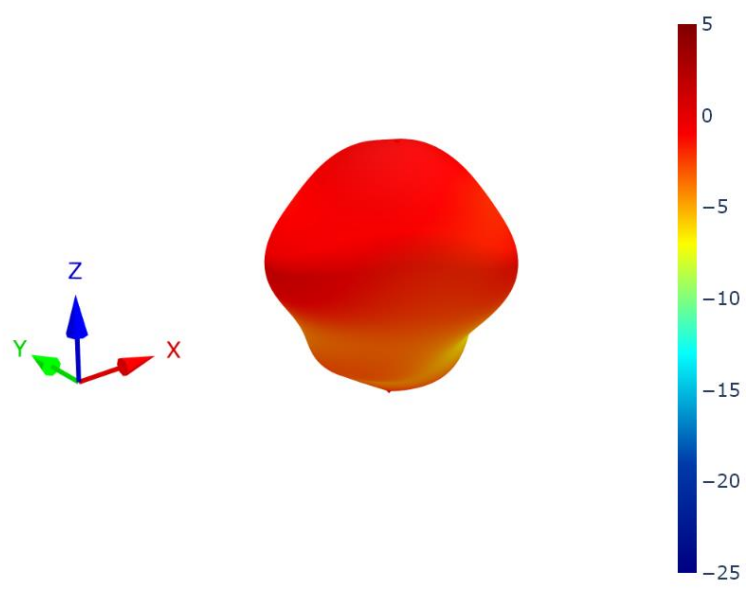

6.3 Free Space Patterns at 1176 MHz

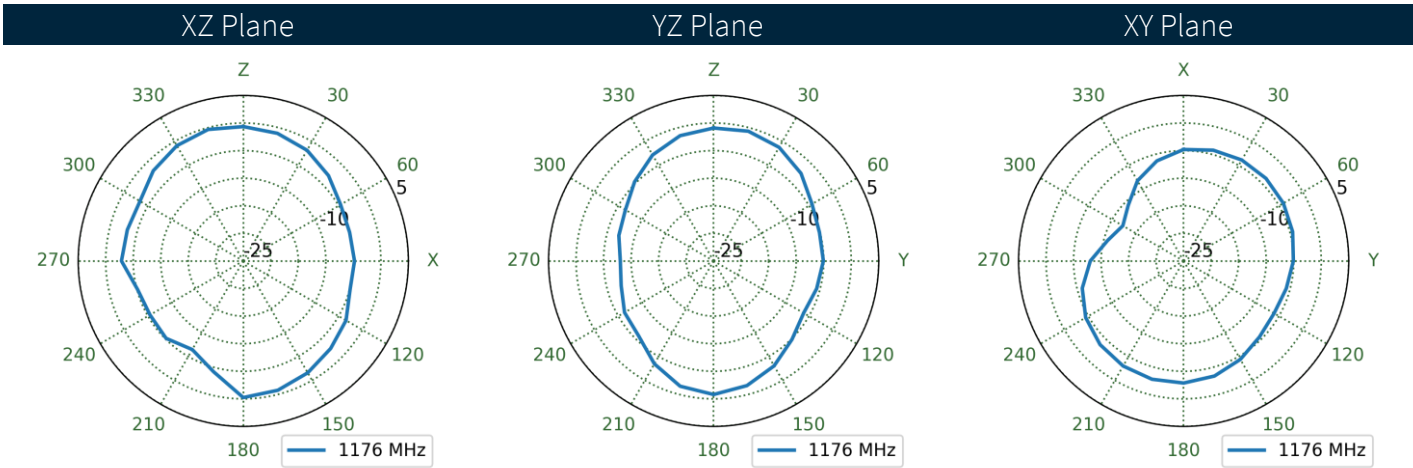
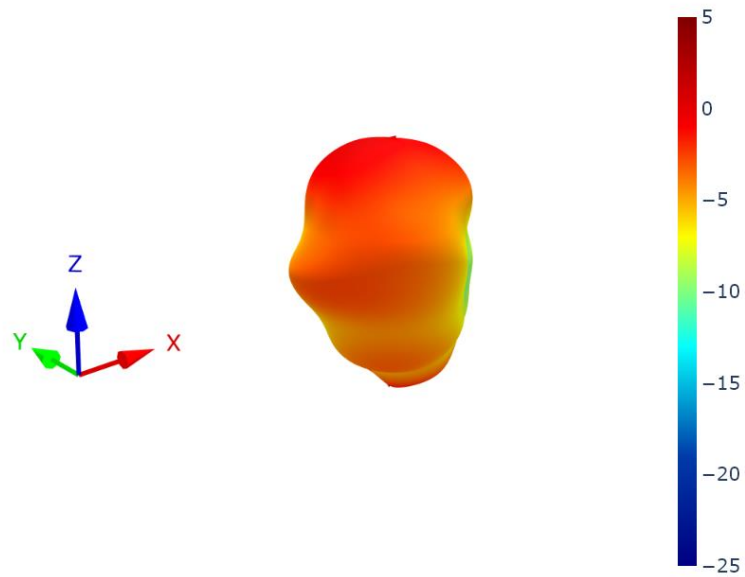

6.4 70x70mm Ground Plane Patterns at 1561 MHz

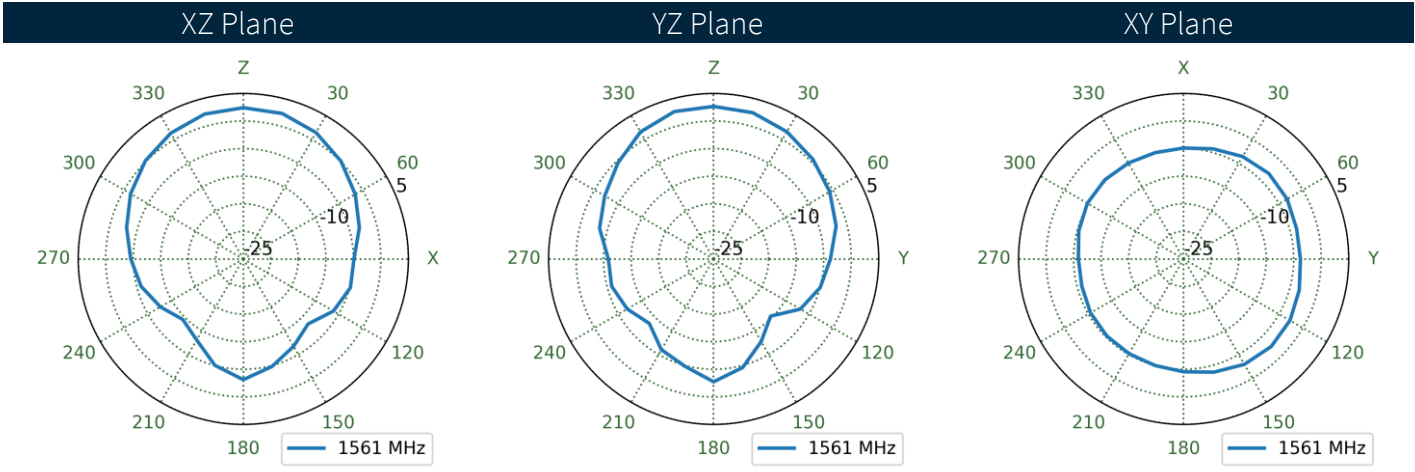
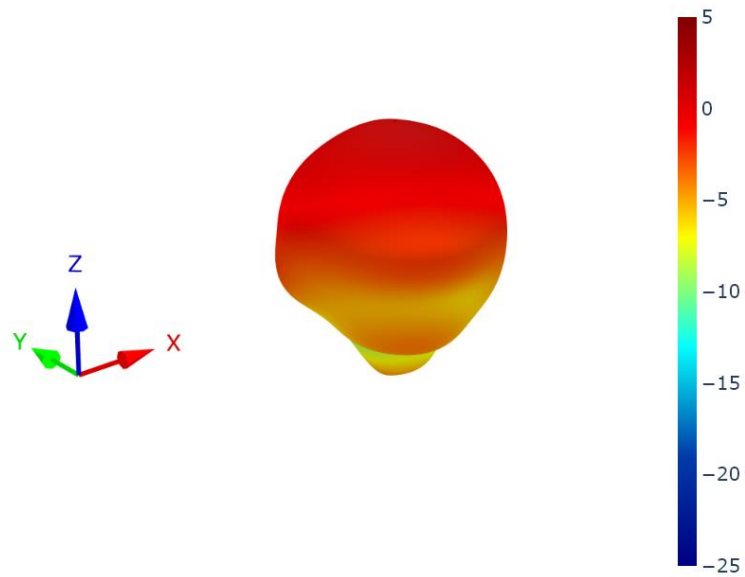

6.5 Free Space Patterns at 1561 MHz

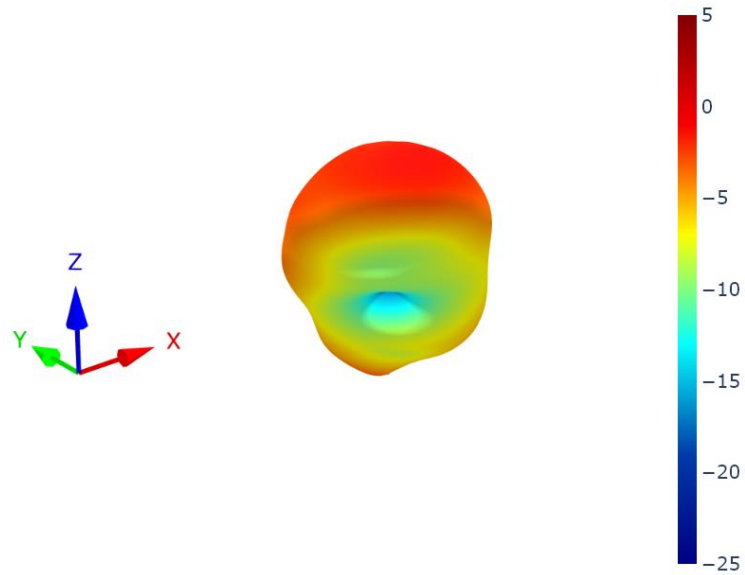

XZ Plane YZ Plane XY Plane

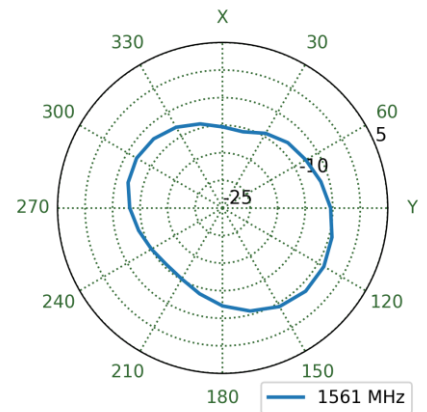
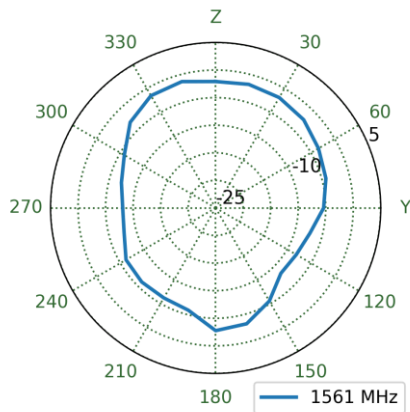
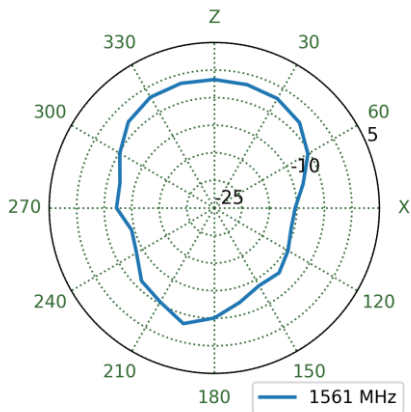

6.6 70x70mm Ground Plane Patterns at 1575 MHz

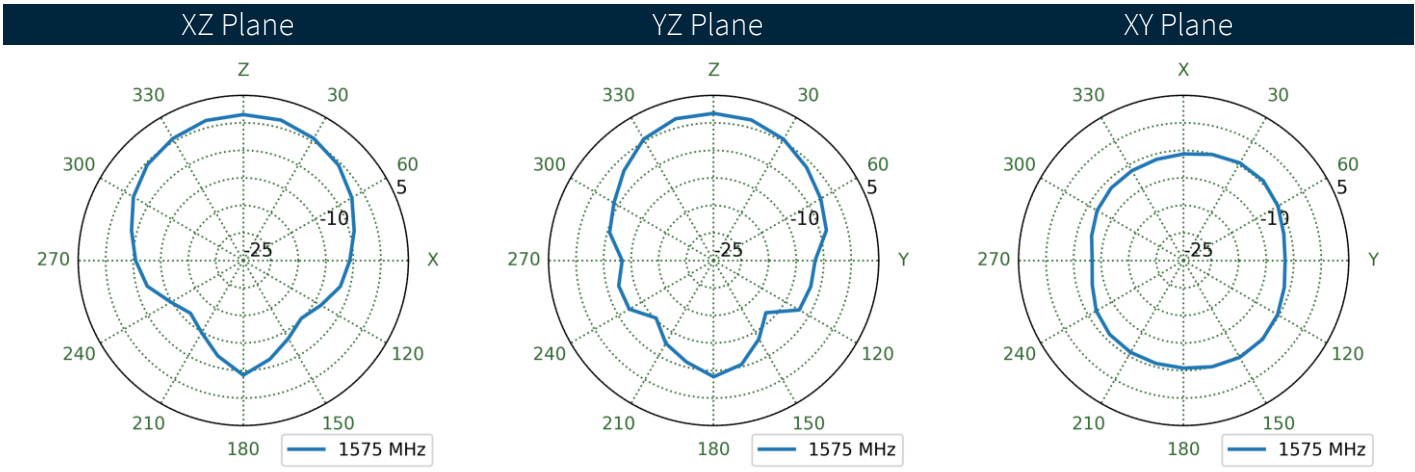
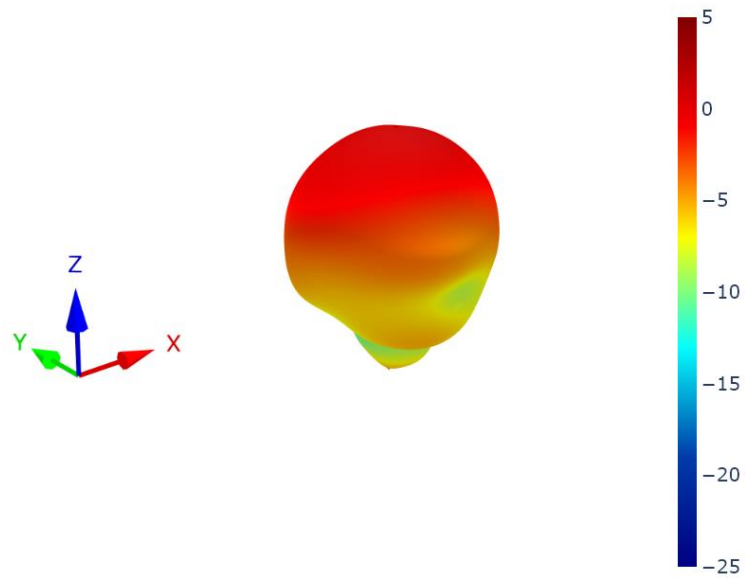

6.7 Free Space Patterns at 1575 MHz

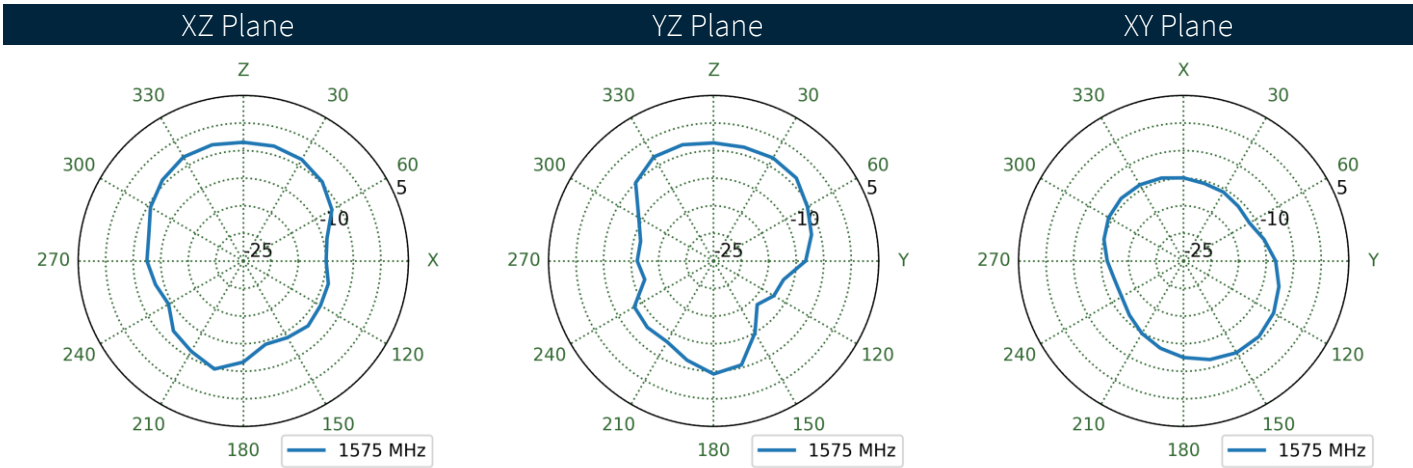
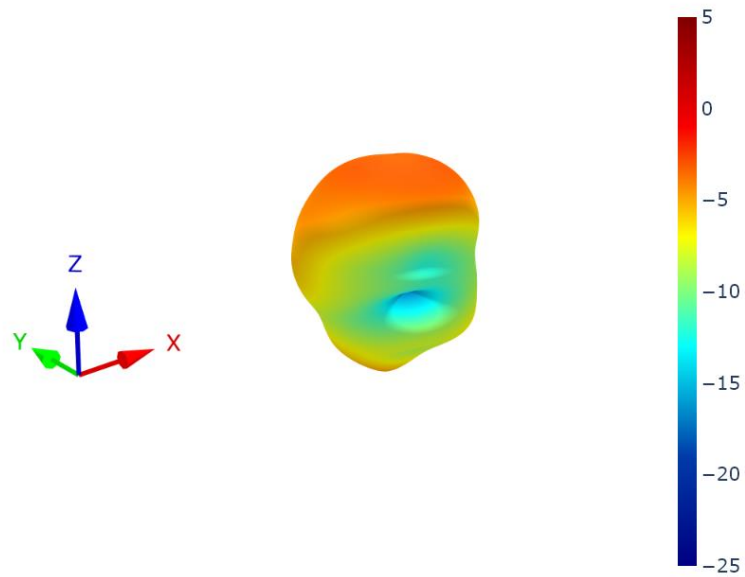

6.8 70x70mm Ground Plane Patterns at 1603 MHz

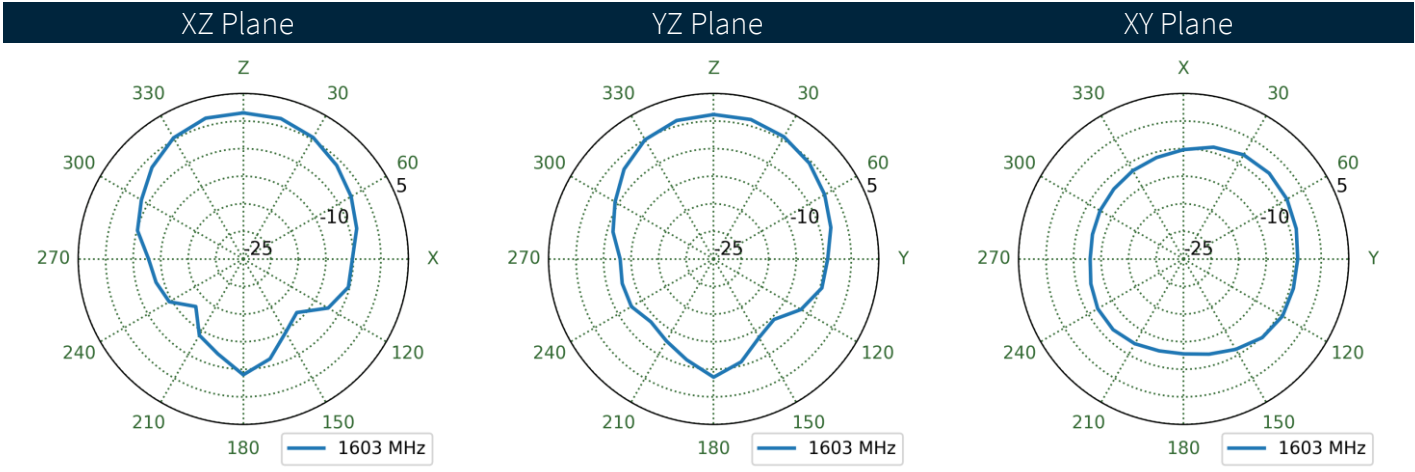
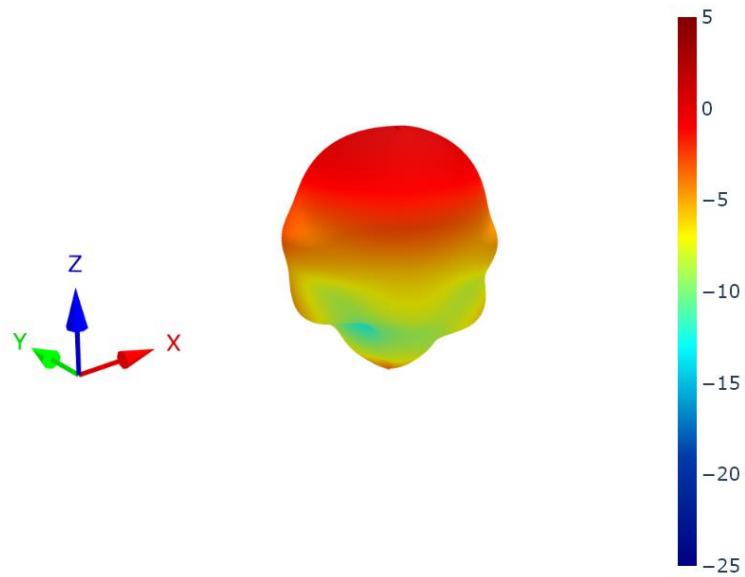

6.9 Free Space Patterns at 1603 MHz

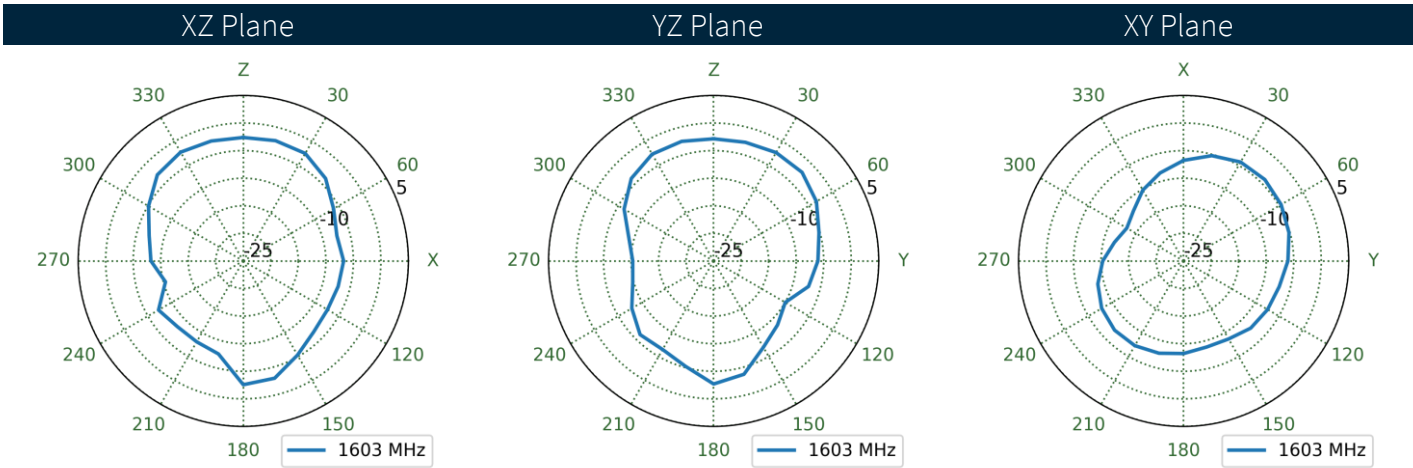
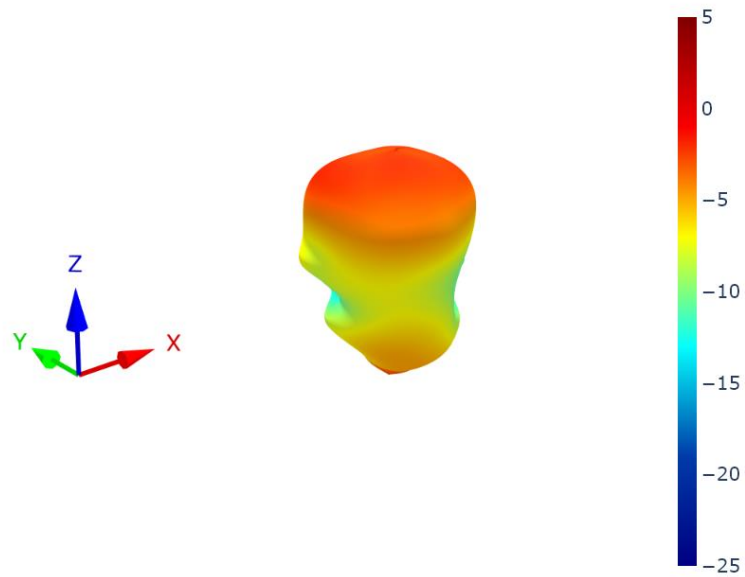

7. LNA Characteristics

7.1 Block Diagram

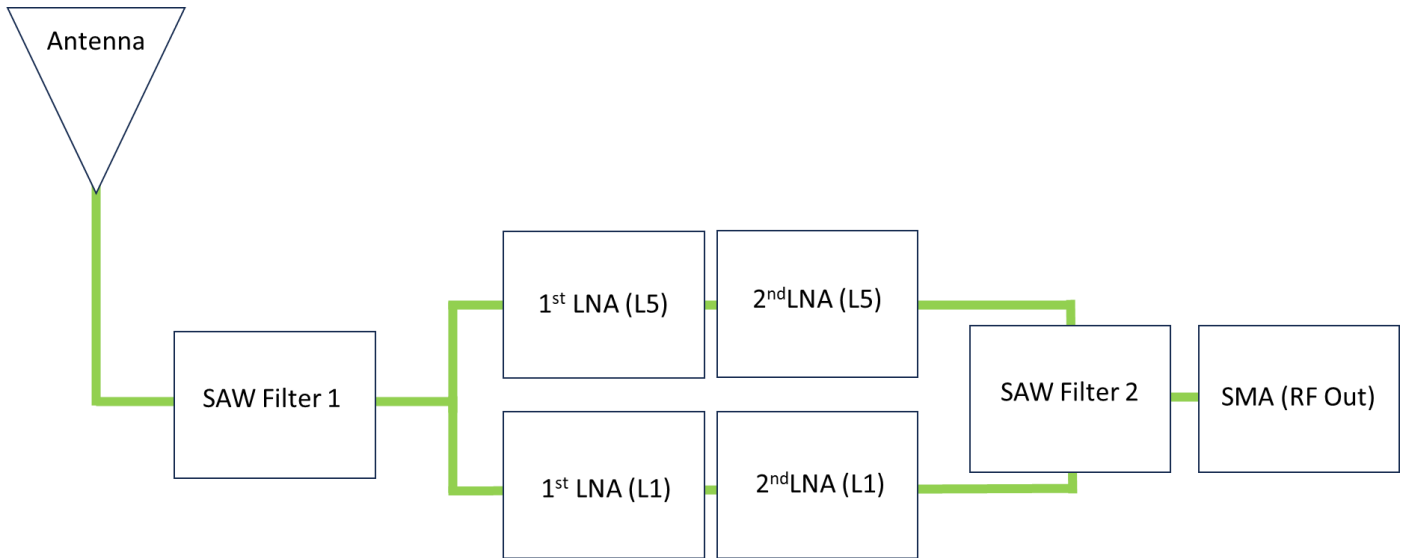

7.2 Gain

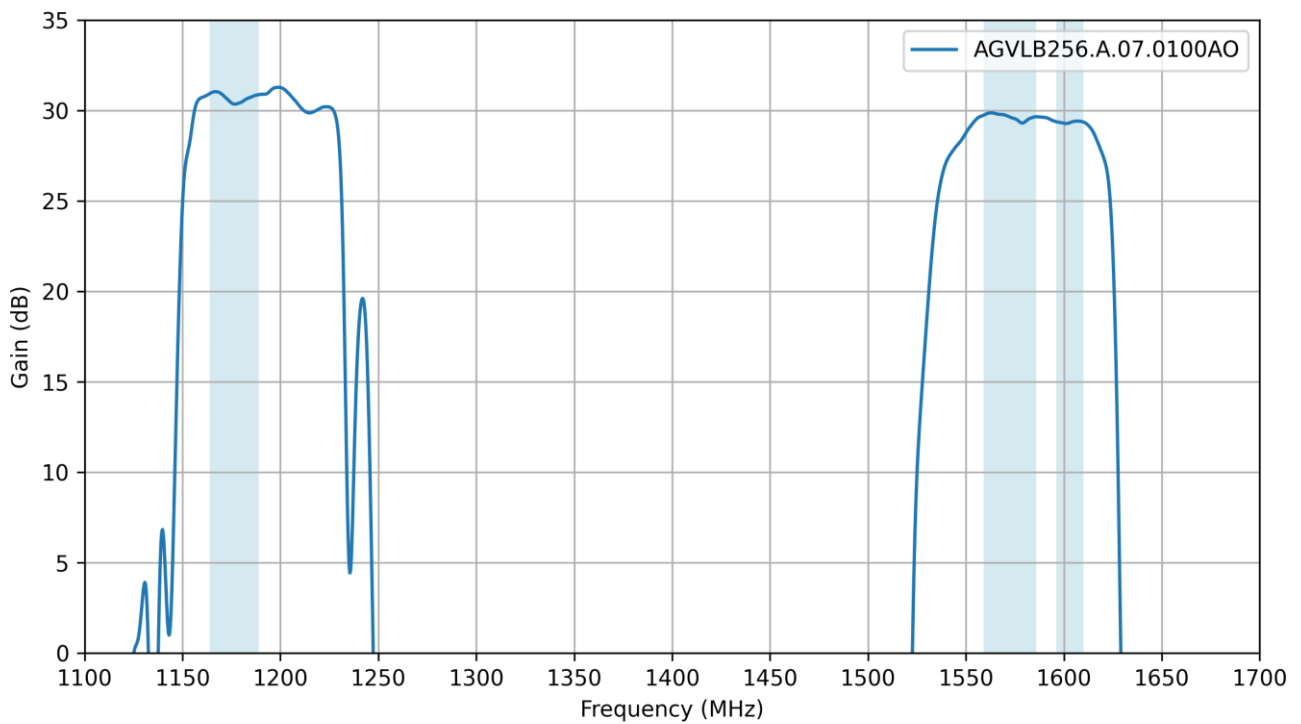

7.3 Noise Figure – Low-Band

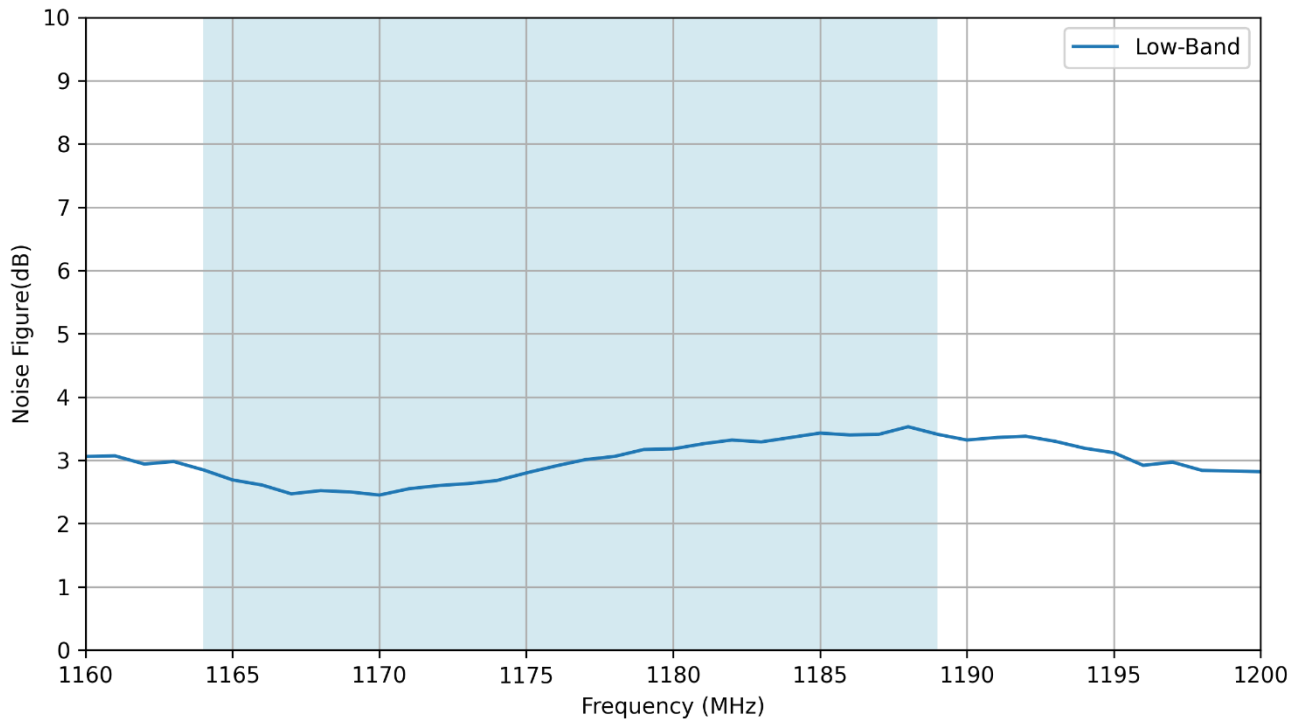

7.4 Noise Figure – High-Band

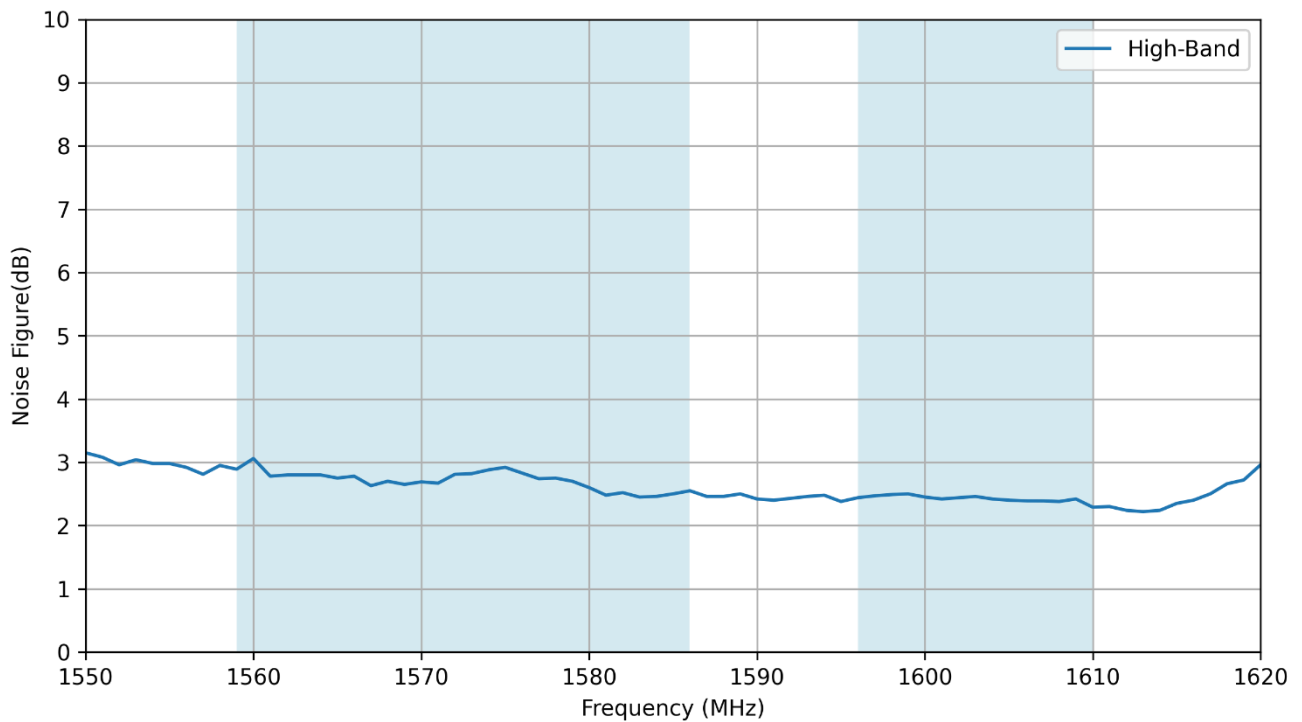

7.5 Group Delay – Low-Band

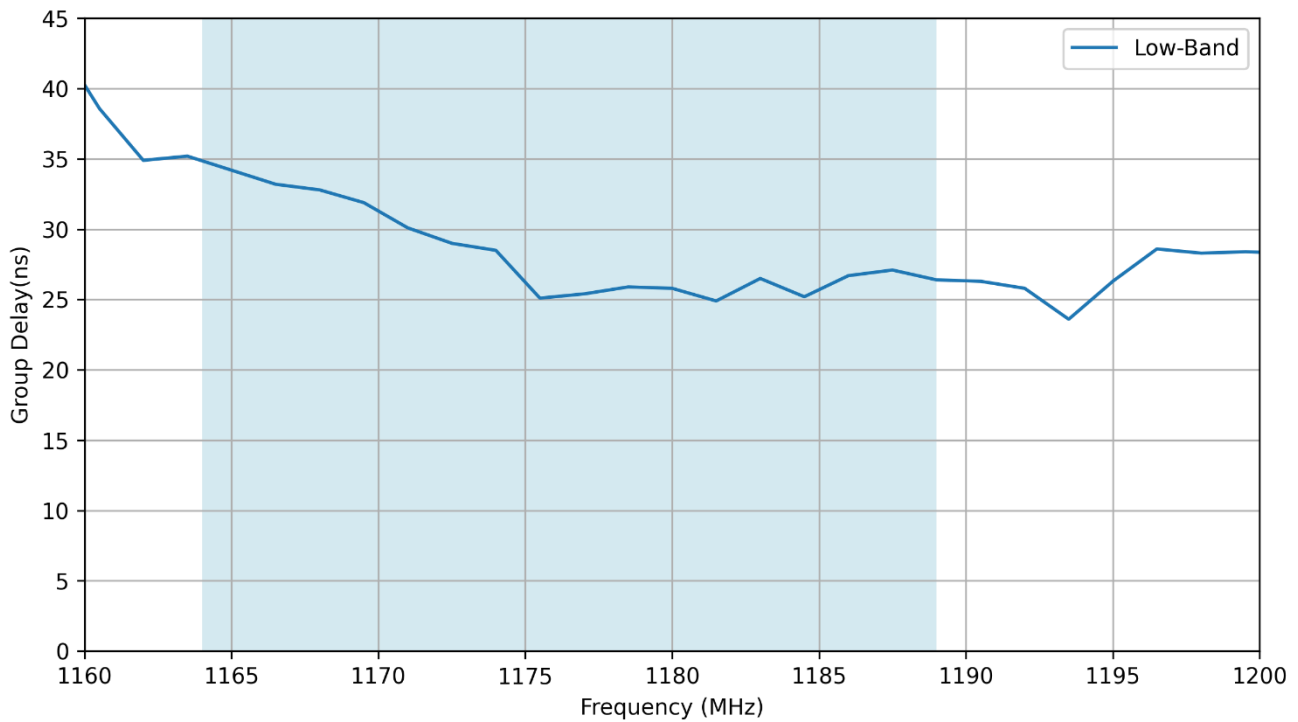

7.6 Group Delay – High-Band

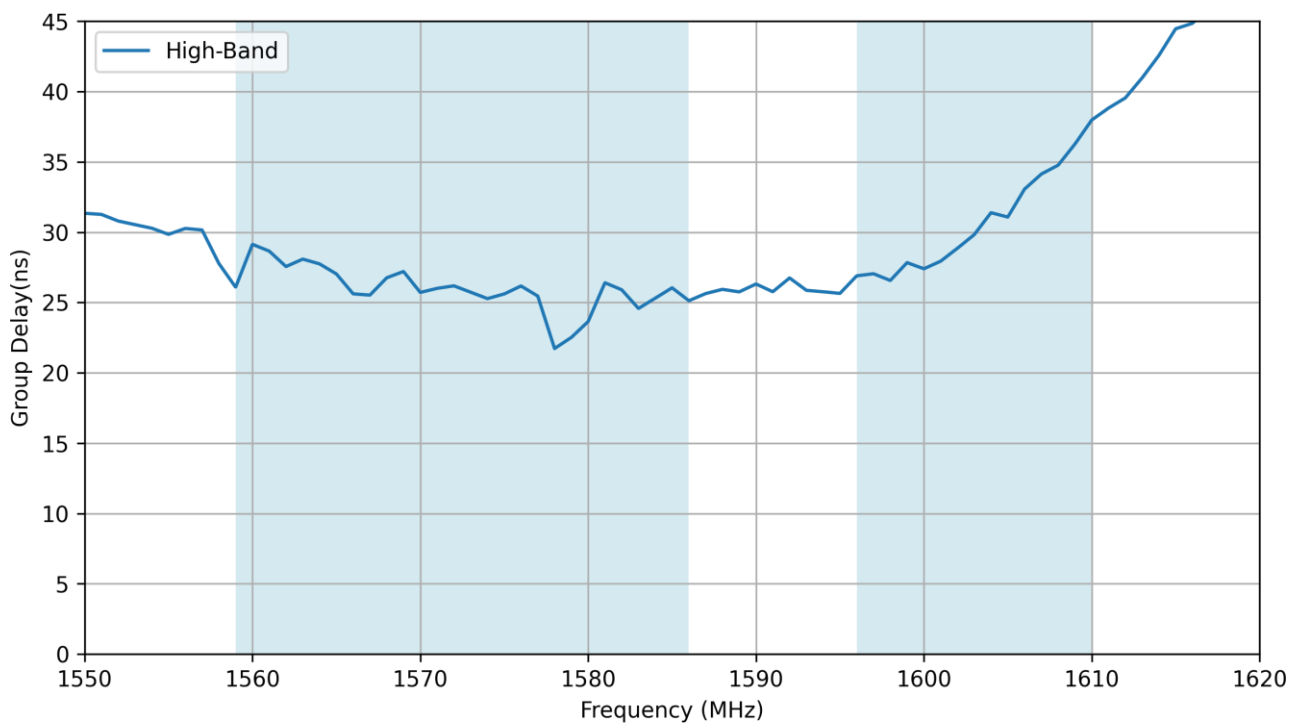

7.7 Out Of Band Rejection

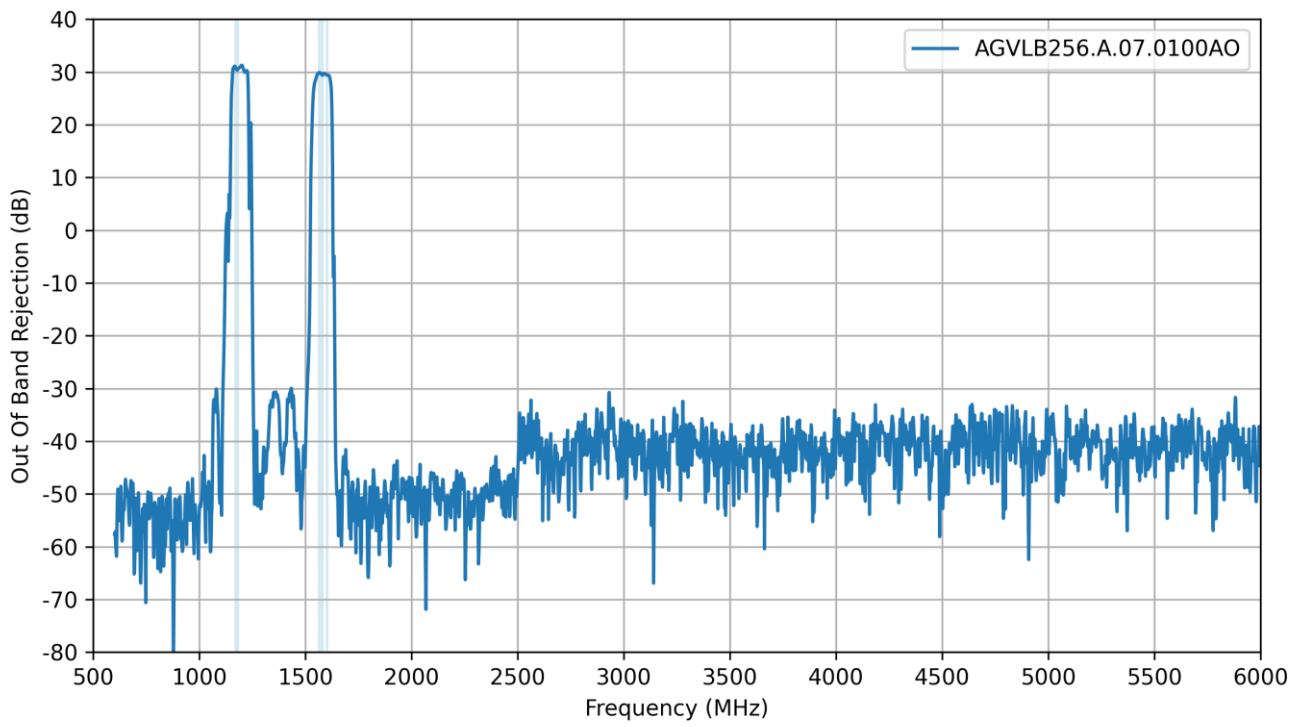

Changelog for the datasheet

SPE-25-8-088 – AGVLB256.A.07.0100AO

Revision: A (Original First Release)	
Date:	2025-03-20
Notes:	Initial Release
Author:	Gary West

Previous Revisions



www.taoglas.com



X-ON Electronics

Largest Supplier of Electrical and Electronic Components

Click to view similar products for [Antennas](#) category:

Click to view products by [Taoglas](#) manufacturer:

Other Similar products are found below :

[930-033-R](#) [EXE902SM](#) [108-00014-50](#) [66089-2406](#) [A09-F8NF-M](#) [A09-F5NF-M](#) [RGFRA1903041A1T](#) [W1049B090](#) [TRABT1560](#)
[WTL2449CQ1-FRSMM](#) [CPL9C](#) [CB27S](#) [0600-00060](#) [Y4503](#) [PAL90209H-FNF](#) [GD53-25](#) [MAF94051](#) [S9025PLSMF](#) [QWFTB120](#)
[MAF94300](#) [FG4403](#) [BB1442NR](#) [GPSCPMM00](#) [ANTDOM-05-01-WPM](#) [ANT-WP868SMA-Y](#) [EXW30BNX](#) [S4908WBFNM](#) [B4305CN](#)
[C27](#) [C27S](#) [CBNC58](#) [EXH160MXI](#) [EXH160SFK](#) [EXC902SM](#) [CB27](#) [ABFT](#) [BB4502NR](#) [B4502N](#) [S4908WBFNF](#) [NMOQ88C](#) [NMOQB](#)
[NMOQC](#) [ANT-GSMGPSPUKS](#) [60210](#) [60140](#) [ANT-8WPIG-UFL](#) [ANT-GPSPUKS](#) [A21H0](#) [29000863](#) [29000848](#)