

SSL990XF



Multi-Constellation Full-Band Antenna

Frequency Coverage: GPS L1, L2, L5 | QZSS L6 | GALILEO E1, E5a, E5b, E6 | BEIDOU B1, B2a, B2b, B3 | GLONASS G1, G2, G3 | NavIC L5 + L-Band

The patent-pending SSL990XF low-profile cross dipole antenna is designed for precision positioning, covering the GPS/QZSS-L1/L2/L5, QZSS-L6, GLONASS-G1/G2/G3, Galileo-E1/E5a/E5b/E6, BeiDou-B1/B2/B2a/B3, and NavIC-L5 frequency bands, including the satellite-based augmentation system (SBAS) available in the region of operation [WAAS (North America), EGNOS (Europe), MSAS (Japan), or GAGAN (India)], as well as L-band correction services.

The SSL990XF utilizes Calian's latest wideband antenna element design. The antenna element provides 67 MHz of signal bandwidth supporting the entire upper GNSS band and L-Band corrections (1539 - 1606 MHz) and 136 MHz of the lower band signal bandwidth (1164 - 1300 MHz). The SSL990XF provides superior Axial Ratio over the same wide bandwidth. The Tallysman SSL990XF has a high peak gain of 2.5 dBi and ≤ 1.5 dB (typical) axial ratio at zenith, enabling excellent multipath mitigation and a very precise phase centre.

The SSL990XF features Tallysmans eXtended Filter (XF) and industry-leading low current, low-noise amplifier (LNA) that includes an integrated low-loss pre-filter to prevent harmonic interference from high-amplitude signals, such as 700 MHz band LTE and other near-band cellular signals. As the radio frequency spectrum has become more congested, the signals or harmonic frequencies of new LTE bands [e.g. 800MHz x 2 = 1600MHz (GLONASSG1)] can affect GNSS antennas and receivers. In North America, planned Ligado signals at 1525 - 1536 MHz can especially impact GNSS antennas that support space-based L-band correction services (1539 - 1559 MHz). New LTE signals in Europe [Band 32 (1452 - 1496 MHz)] and Japan [Bands 11 and 21 (1476 - 1511 MHz)] have also been observed to interfere with GNSS signals. In addition, Inmarsat satellite communication (uplink: 1626.5 - 1660.5 MHz) can also affect GNSS signals. The new Tallysman XF antennas have been designed to mitigate out-of-band signals and prevent GNSS antenna saturation. Calian's custom XF filtering mitigates all existing signals and new Ligado and LTE signals, enabling the antennas and attached GNSS receivers to perform optimally.

The SSL990XF weighs only 88 grams. It is housed in a weatherproof (IP67) enclosure and is mounted using screws through the aluminum ground plane. The aluminum also provides a slot base and a waterproofing O-ring. Two antenna cable connector options are available the first is a female SMA and the second is an MMCX. It is an ideal antenna for precision UAV and all applications where light weight and precision matters.



Config -1



Config -2

Applications

- Autonomous unmanned aerial vehicles (UAVs)
- Precision GNSS positioning
- Precision land survey positioning
- Mission-critical GNSS timing
- Marine and avionics systems

Features

- Very low noise preamp (2.5 dB typ.)
- Axial ratio (≤ 1 dB at zenith)
- High LNA gain (28 dB typ. | 35 dB typ.)
- Low current (30 mA typ. | 35 mA typ.)
- ESD circuit protection (15 kV)
- Invariant performance from 2.5 to 16 VDC
- REACH and RoHS compliant

Benefits

- Extremely light (88 g)
- Excellent RH circular polarized signal reception
- Great multipath rejection
- Increased system accuracy
- Excellent signal-to-noise ratio
- Industrial temperature range

About Calian: With global headquarters and manufacturing in Ottawa, Canada, Calian is a leading manufacturer of high-precision antennas and components for Global Navigation Satellite System (GNSS) applications. Calian's mission is to support the needs of a new generation of positioning systems by delivering unprecedented antenna precision at competitive prices. Learn more at www.calian.com

Revision: 202403

Contact us:
info@tallysman.com
T: +1 613 591-3131

Multi-Constellation Full-Band Antenna

Frequency Coverage: GPS L1, L2, L5 | QZSS L6 | GALILEO E1, E5a, E5b, E6 | BEIDOU B1, B2a, B2b, B3 | GLONASS G1, G2, G3 | NavIC L5 + L-Band

Antenna (Measured with 100 mm ground plane)

Technology Full-spectrum, RHCP cross dipole antenna

		Gain	Axial Ratio
		dBic typ. at Zenith	dB at Zenith
GNSS			
GPS / QZSS	L1	3.0	≤ 1.0
	L2	3.0	≤ 1.0
	L5	2.2	≤ 1.0
GLONASS	G1	3.0	≤ 1.0
	G2	2.5	≤ 1.0
	G3	2.5	≤ 1.0
Galileo	E1	3.0	≤ 1.0
	E5A	2.0	≤ 1.0
	E5B	2.5	≤ 1.0
	E6	2.3	≤ 1.0
BeiDou	B1	3.0	≤ 1.0
	B2a	2.0	≤ 1.0
	B2b	2.5	≤ 1.0
	B3	2.2	≤ 1.0
IRNSS / NavIC	L5	2	≤ 1.0
QZSS	L6	2.2	≤ 1.0
L-Band Services (1525 MHz - 1559 MHz)		2.5	≤ 1.0
Satellite Communications			
Iridium		-	-
Globalstar		-	-
Phase Centre			
PC Variation	< 5 mm typ.		
PC Offset	TBD		

Mechanicals

Mechanical Size	-1: 100 mm (dia.) x 32 mm (h.) -2: 79 mm (dia.) x 32 mm (h.)
Weight	88 g (-1), 75 g (-2)
Radome	EXL-9330
Mount	3 screws
Available Connectors	SMA or MMCX Female

Environmental

Operating Temperature	-40 °C to +85 °C
Storage Temperature	-55 °C to +95 °C
Vibration	MIL-STD 810G Method 514.6
Shock	50G, 11 ms X,Y,Z
IP Rating	IP67
Compliance	IPC-A-610, FCC, RED / CE Mark, RoHS, REACH

Warranty

Parts and Labour	3-year standard warranty
------------------	--------------------------

Low Noise Amplifier (LNA) - Measured at 3V and 25°C

Frequency Bandwidth	Out of Band Rejection
Lower Band	1164 - 1300 MHz
L-Band Corr.	1539 - 1559 MHz
Upper Band	1559 - 1606 MHz

≥ 85 dB @ ≤ 0950 MHz
≥ 70 dB @ ≤ 1125 MHz
≥ 75 dB @ ≥ 1350 MHz
≥ 65 dB @ ≤ 1500 MHz
≥ 45 dB @ ≤ 1525 MHz
≥ 05 dB @ ≤ 1536 MHz
≥ 30 dB @ ≥ 1626 MHz
≥ 65 dB @ ≥ 1650 MHz

Architecture	eXtended Filtering
Gain	28 dB typ., 35 dB typ.
Noise Figure	2.5 dB typ.
VSWR	< 1.5:1 typ., 1.8:1 max.
Supply Voltage Range	2.5 to 16 VDC nominal, up to 50mV p-p ripple
Supply Current	30 mA typ. (28 dB), 35 mA typ. (35 dB)
ESD Circuit Protection	15 kV air discharge
P 1dB Output	13.3 dBm @ L1 , 13.1 dBm @ L2/L5
LNA Group Delay	20 ns @ L1 , 3 ns @ L2, 48 ns @ L5

Mechanical Diagram

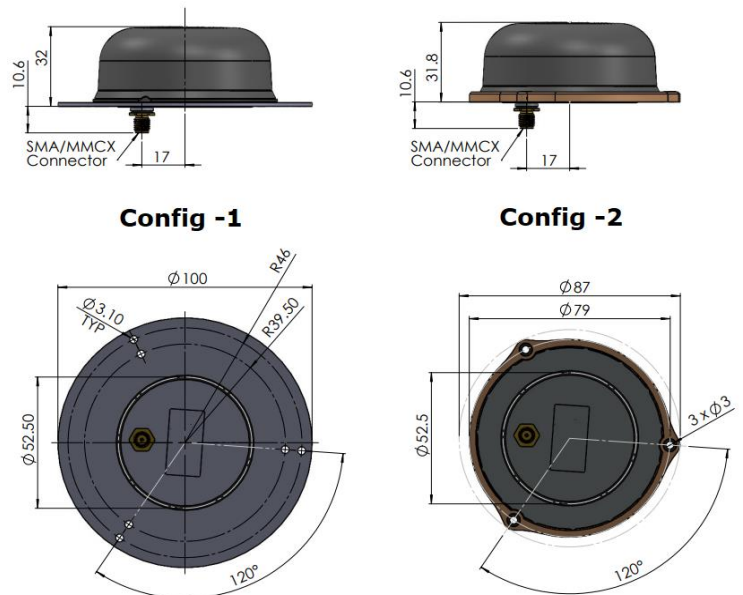

Ordering Information

Part Number	33-SSL990XF-Y-GG-xx
	Y = config., GG = gain (28 or 35); xx = connector (SMA Female = 20, MMCX = 19)

X-ON Electronics

Largest Supplier of Electrical and Electronic Components

Click to view similar products for [Antennas](#) category:

Click to view products by [Tallysman](#) manufacturer:

Other Similar products are found below :

[930-033-R](#) [EXE902SM](#) [108-00014-50](#) [66089-2406](#) [A09-F8NF-M](#) [A09-F5NF-M](#) [RGFRA1903041A1T](#) [W1049B090](#) [TRABT1560](#)
[WTL2449CQ1-FRSMM](#) [CPL9C](#) [CB27S](#) [0600-00060](#) [Y4503](#) [PAL90209H-FNF](#) [GD53-25](#) [MAF94051](#) [S9025PLSMF](#) [QWFTB120](#)
[MAF94300](#) [FG4403](#) [BB1442NR](#) [GPSCPMM00](#) [ANTDOM-05-01-WPM](#) [ANT-WP868SMA-Y](#) [EXW30BNX](#) [S4908WBFNM](#) [B4305CN](#)
[C27](#) [C27S](#) [CBNC58](#) [EXH160MXI](#) [EXH160SFK](#) [EXC902SM](#) [CB27](#) [ABFT](#) [BB4502NR](#) [B4502N](#) [S4908WBFNF](#) [NMOQ88C](#) [NMOQB](#)
[NMOQC](#) [ANT-GSMGPSPUKS](#) [60210](#) [60140](#) [ANT-8WPIG-UFL](#) [ANT-GPSPUKS](#) [A21H0](#) [29000863](#) [29000848](#)