

# TW5794



## TW5794 Smart GNSS Antenna for Precise Positioning and Heading

### Overview

The TW5794 is a multi-band (L1/L2), multi-constellation integrated GNSS receiver/antenna with integrated L-Band receiver for PointPerfect PPP-RTK corrections. The TW5794 is capable of providing sub 1 meter accuracy stand alone, sub 6 cm accuracy with PPP-RTK corrections and sub 1 cm with RTK corrections to support the most demanding navigation, automation and precision mobility applications. Two TW5794's may be combined as a Moving Base RTK Precise Heading base and rover pair.

### Interference Resilience

The TW5794 incorporates a latest generation multi-band (L1/L2) GNSS receiver with a Tallysman Accutenna® multi-band (L1/L2/L-Band) triple band dual feed patch. The state of the art GNSS receiver supports concurrent tracking of all four major constellations (GPS, BeiDou, Galileo and GLONASS) in multiple frequency bands. The multi-band (L1/L2) architecture is highly effective method for the removal of ionospheric error. The TW5794 employs multi-stage filtering with low noise figure LNAs, combined with the dual feed Accutenna®, which greatly improves the rejection of multi-path signal interference.

### Precise Point Positioning

The TW5794 offers support for a broad range of corrections services (RTCM RTK, networked PPP-RTK or PointPerfect PPP-RTK over L-Band) allowing performance optimization according to each application's unique requirements. The concurrent multi-band (L1/L2) access to all four satellite constellations improves the receiver's convergence capability to deliver a quick, precise and reliable position solution which is resilient to ionospheric errors and improves resilience against interference and jamming.

The TW5794 may also be configured to operate in an RTK mode as either a base or rover for sub cm precision. For Precise Heading applications, two TW5794's may be arranged as a moving base RTK base and rover pair. The base device may receive PPP-RTK corrections for increased positional accuracy while concurrently sending RTCM correction messages to the rover.

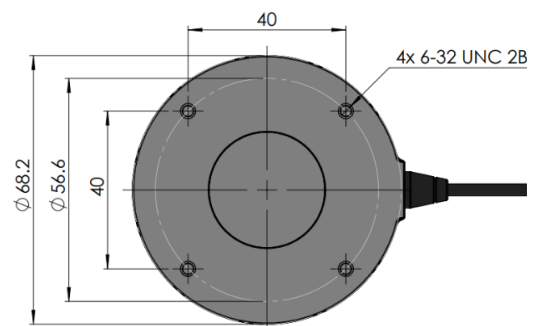
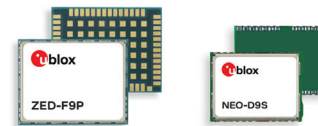

Mechanical Dimensions (mm)

### Features

- Improved noise immunity with multi-band u-blox ZED F9P GNSS receiver
- PointPerfect PPP-RTK (networked and L-Band)
- Improved multi-path rejection with Dual feed Accutenna®
- Multi-band GNSS receiver is resilient to ionospheric errors
- High reliability timing with expansive constellation array
- Moving base RTK Precise Heading base/rover pair
- Exceptional position performance standalone without correction services
- 5V operation
- USB 2.0 (or RS-232) signalling
- Industrial grade IP67 enclosure
- Rugged fixed mount
- Multiple cable lengths (5m, 15m and 25m)
- Available with conical radome

# TW5794 Smart GNSS Antenna

## Specifications

Antenna	
Architecture.....	Multi-band (L1/L2), Dual Feed
Axial Ratio.....	L1: < 1 dB typical.
Frequencies.....	GPS L1C/A L2C, GLO L1OF L2OF, GAL E1B/C E5b, BDS B1I B2I, QZSS L1C/A L2C
SBAS L1 C/A.....	WAAS, EGNOS, MSAS, GAGAN
Channels.....	184-channel u-blox F9 engine
Anti-jamming.....	Active CW detection
Corrections Receiver.....	L-Band PPP-RTK (SSR)

Interface	
Pwr, Gnd	
33-5794-19-yy-zz.....	Data: USB 2.0 Type A Male
33-5794-29-yy-zz.....	Data: RS-232; Timepulse: RS-232

Serial Protocol	
Output.....	NMEA 0183, UBX Binary, RTCM v3.3, SPARTN v2.0
Baud Rate.....	Configurable
Update Rate.....	9 Hz (4); 10 Hz (GPS+GAL+BDS); 20 Hz (GPS+GAL); 20 Hz (GPS+GLO); 16 Hz (GP+BDS); 25 Hz (GPS)

Mechanical	
Dimensions.....	68.2 mm dia. x 22 mm H
Weight.....	185 g
Mounting Method.....	Industrial grade fixed Mount
Cable Length.....	5, 15, 25m with RJ45 termination

Electrical	
Voltages.....	5 VDC
Current.....	0.6 Watts (nominal operating) Measured @ 5VDC supply

Environmental	
Operating Temperature.....	-40°C to +85°C
Storage Temperature.....	-40°C to +85°C
Weatherproof.....	IP67
Shock.....	Vertical axis 50G, other axis 30G 3 axis sweep – 15 min
Vibration.....	10-200 Hz log sweep 3G

Sensitivity	
Tracking & Nav.....	-160 dBm
Reacquisition.....	-160 dBm
Hot starts.....	-158 dBm
Cold starts.....	-147 dBm

Acquisition	
Cold start.....	25 sec
Aided start.....	3 sec
Reacquisition.....	2 sec

Horizontal Position Accuracy (4 Constellations)	
Standard PVT.....	1.5m CEP
Standard SBAS.....	1.0m CEP
Corrected RTK.....	0.01m + 1ppm CEP
Augmented SPARTN (PPP-RTK).....	<0.06m CEP
SPARTN Convergence.....	<45 sec*

Heading	
Dynamic Heading Accuracy.....	0.3° (30 m/sec)

Timing	
Timing Accuracy.....	30 ns RMS

## Ordering Information:

33-5794-19-yy-zz-PC0 (USB 2 Type A Male; Data: USB 2.0, PC0 = NMEA out, no adaptor cable.)  
33-5794-29-yy-zz-PC0 (RJ45; Data: RS-232, Timepulse RS-232, PC0 = NMEA out, no adaptor cable.)

yy = Radome (00=grey conical, 10=grey low profile, 01=white conical, 11=white low profile)  
zz = RS-232 Cable length in meters. Standard is 5m. (15m and 25m are special order only);  
USB: 0S: 1.5m (Standard); 0L: 3m (Special order)

**33-5794-19-yy-zz-PC0 SDK Test Adaptor required for programming**  
**33-5794-29-yy-zz-PC0 SDK Test Adaptor required for programming**

**Not Applicable**  
**33-0095-13**

**About Calian GNSS:** With global headquarters and manufacturing in Ottawa, Canada, Calian GNSS is a leading manufacturer of high-precision antennas and components for Global Navigation Satellite System (GNSS) applications. Calian GNSS' mission is to support the needs of a new generation of positioning systems by delivering unprecedented antenna precision at competitive prices. Learn more at [www.calian.com/GNSS](http://www.calian.com/GNSS)

**Contact us:**  
[info.gnss@calian.com](mailto:info.gnss@calian.com)  
T: +1 613 591-3131

© 2024 Calian GNSS Ltd. All rights reserved. Calian, the "Confidence. Engineered." tag line and the Calian logo are trademarks or registered trademarks of Calian GNSS Ltd. and/or its affiliates in Canada and certain other countries. All other trademarks mentioned in this document are the property of their respective owners. This document contains Calian proprietary information. Use, disclosure, copying or distribution of information requires the written permission of Calian GNSS Ltd. The information presented is subject to change without notice. Calian assumes no responsibility for any errors or omissions in this document. Calian GNSS Ltd. hereby disclaims any and all warranties and liabilities of any kind.

Calian GNSS Ltd.  
36 Steacie Drive,  
Ottawa ON  
K2K 2A9 Canada

[www.calian.com/GNSS](http://www.calian.com/GNSS)

## X-ON Electronics

Largest Supplier of Electrical and Electronic Components

*Click to view similar products for [Antennas](#) category:*

*Click to view products by [Tallysman](#) manufacturer:*

Other Similar products are found below :

[930-033-R](#) [EXE902SM](#) [108-00014-50](#) [66089-2406](#) [A09-F8NF-M](#) [A09-F5NF-M](#) [RGFRA1903041A1T](#) [W1049B090](#) [TRABT1560](#)  
[WTL2449CQ1-FRSMM](#) [CPL9C](#) [CB27S](#) [0600-00060](#) [Y4503](#) [PAL90209H-FNF](#) [GD53-25](#) [MAF94051](#) [S9025PLSMF](#) [QWFTB120](#)  
[MAF94300](#) [FG4403](#) [BB1442NR](#) [GPSCPMM00](#) [ANTDOM-05-01-WPM](#) [ANT-WP868SMA-Y](#) [EXW30BNX](#) [S4908WBFNM](#) [B4305CN](#)  
[C27](#) [C27S](#) [CBNC58](#) [EXH160MXI](#) [EXH160SFK](#) [EXC902SM](#) [CB27](#) [ABFT](#) [BB4502NR](#) [B4502N](#) [S4908WBFNF](#) [NMOQ88C](#) [NMOQB](#)  
[NMOQC](#) [ANT-GSMGPSPUKS](#) [60210](#) [60140](#) [ANT-8WPIG-UFL](#) [ANT-GPSPUKS](#) [A21H0](#) [29000863](#) [29000848](#)