

## SLLIMM™-nano, 2<sup>nd</sup> series IPM, 3 A, 600 V, 3-phase IGBT inverter bridge

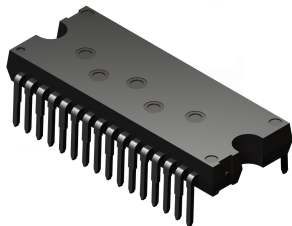

N2DIP-26L type L

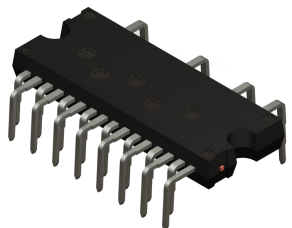

N2DIP-26L type Z

### Features

- IPM 3 A, 600 V, 3-phase IGBT inverter bridge including 3 control ICs for gate driving and freewheeling diodes
- 3.3 V, 5 V, 15 V TTL/CMOS input comparators with hysteresis and pull-down/pull-up resistors
- Internal bootstrap diode
- Optimized for low electromagnetic interference
- Undervoltage lockout
- $V_{CE(SAT)}$  negative temperature coefficient
- Blanking time  $t_{dead} \geq 1 \mu s$
- Shutdown function
- Interlocking function
- Op-amp for advanced current sensing
- Comparator for fault protection against overcurrent
- Isolation ratings of 1500 Vrms/min.
- Optimized pinout for easy board layout
- UL recognition: UL 1557, file E81734

### Applications

- 3-phase inverters for motor drives
- Dish washers, refrigerator compressors, heating systems, air-conditioning fans, draining and recirculation pumps



### Description

This second series of SLLIMM (small low-loss intelligent molded module)-nano provides a compact, high-performance AC motor drive in a simple, rugged design. It is composed of six improved IGBTs with freewheeling diodes and three half-bridge HVICs for gate driving, providing low electromagnetic interference (EMI) characteristics with optimized switching speed. The package is designed to allow a better and more easily screwed-on heatsink, and is optimized for thermal performance and compactness in built-in motor applications or other low power applications where assembly space is limited. This IPM includes a completely uncommitted operational amplifier and a comparator that can be used to design a fast and efficient protection circuit. SLLIMM™ is a trademark of STMicroelectronics.

#### Product status link

[STGIPQ3HD60-HL](#)
[STGIPQ3HD60-HZ](#)

#### Product summary

##### Order code: STGIPQ3HD60-HL

<b>Marking</b>	GIPQ3HD60-HL
<b>Package</b>	N2DIP-26L type L
<b>Packing</b>	Tube

##### Order code: STGIPQ3HD60-HZ

<b>Marking</b>	GIPQ3HD60-HZ
<b>Package</b>	N2DIP-26L type Z
<b>Packing</b>	Tube

# 1 Internal schematic diagram and pin configuration

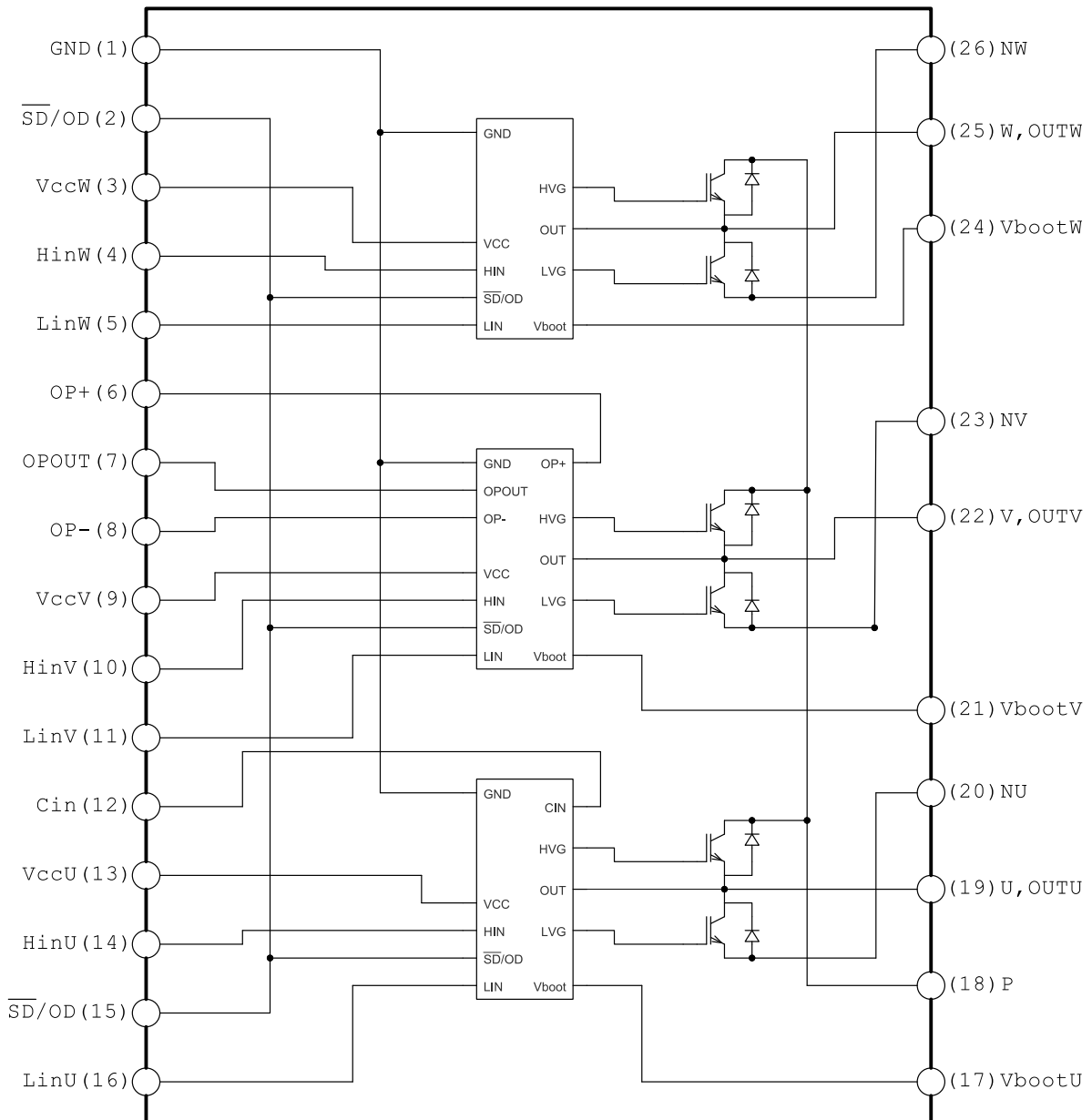
**Figure 1. Internal schematic diagram**

ADG090820161400MT

**Table 1. Pin description**

Pin	Symbol	Description
1	GND	Ground
2	$\overline{\text{SD/OD}}$	Shutdown logic input (active low)/open-drain (comparator output)
3	V <sub>CC</sub> W	Low voltage power supply W phase
4	HIN W	High-side logic input for W phase
5	LIN W	Low-side logic input for W phase
6	OP+	Op-amp non inverting input
7	OP <sub>OUT</sub>	Op-amp output
8	OP-	Op-amp inverting input
9	V <sub>CC</sub> V	Low-voltage power supply V phase
10	HIN V	High-side logic input for V phase
11	LIN V	Low-side logic input for V phase
12	CIN	Comparator input
13	V <sub>CC</sub> U	Low-voltage power supply for U phase
14	HIN U	High-side logic input for U phase
15	$\overline{\text{SD/OD}}$	Shutdown logic input (active low)/open-drain (comparator output)
16	LIN U	Low-side logic input for U phase
17	V <sub>BOOT</sub> U	Bootstrap voltage for U phase
18	P	Positive DC input
19	U, OUT <sub>U</sub>	U phase output
20	N <sub>U</sub>	Negative DC input for U phase
21	V <sub>BOOT</sub> V	Bootstrap voltage for V phase
22	V, OUT <sub>V</sub>	V phase output
23	N <sub>V</sub>	Negative DC input for V phase
24	V <sub>BOOT</sub> W	Bootstrap voltage for W phase
25	W, OUT <sub>W</sub>	W phase output
26	N <sub>W</sub>	Negative DC input for W phase

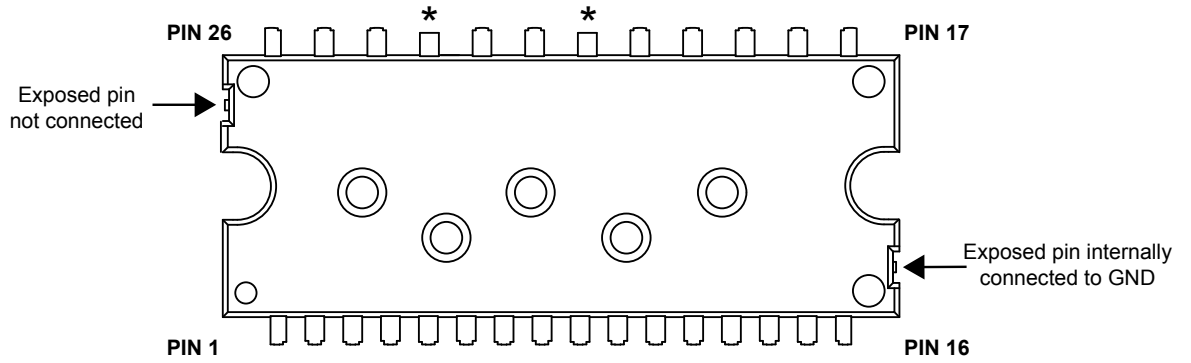
**Figure 2. Pin layout (top view) - N2DIP-26L type L**

\* Dummy pins internally connected to P (positive DC input)

GADG181220181209IG

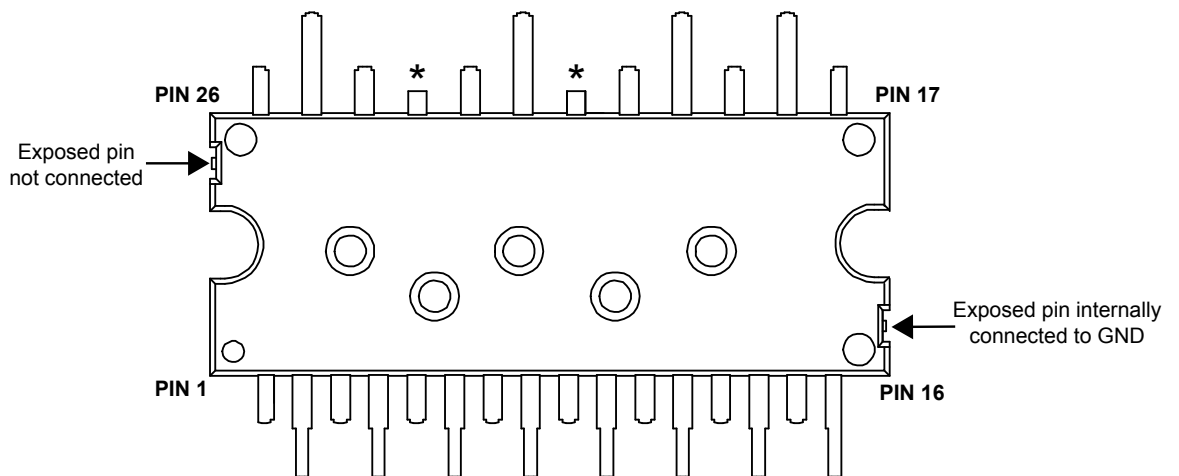
**Figure 3. Pin layout (top view) - N2DIP-26L type Z**

\* Dummy pins internally connected to P (positive DC input)

GADG181220181216IG

## 2 Electrical ratings

$T_J = 25\text{ °C}$  unless otherwise specified

### 2.1 Absolute maximum ratings

**Table 2. Inverter part**

Symbol	Parameter	Value	Unit
$V_{CES}$	Collector-emitter voltage for each IGBT ( $V_{IN}^{(1)} = 0$ )	600	V
$I_C$	Continuous collector current for each IGBT ( $T_C = 25\text{ °C}$ )	3	A
$I_{CP}^{(2)}$	Peak collector current for each IGBT (less than 1 ms)	18	A
$P_{TOT}$	Total power dissipation for each IGBT ( $T_C = 25\text{ °C}$ )	12	W

1. Applied among  $HIN_x$ ,  $LIN_x$  and GND for  $x = U, V, W$
2. Pulse width limited by maximum junction temperature.

**Table 3. Control part**

Symbol	Parameter	Min.	Max.	Unit
$V_{CC}$	Low voltage power supply	-0.3	21	V
$V_{boot}$	Bootstrap voltage	-0.3	620	V
$V_{OUT}$	Output voltage applied among $OUT_U$ , $OUT_V$ , $OUT_W$ - GND	$V_{boot} - 21$	$V_{boot} + 0.3$	V
$V_{CIN}$	Comparator input voltage	-0.3	$V_{CC} + 0.3$	V
$V_{op+}$	Op-amp non-inverting input	-0.3	$V_{CC} + 0.3$	V
$V_{op-}$	Op-amp inverting input	-0.3	$V_{CC} + 0.3$	V
$V_{IN}$	Logic input voltage applied among $HIN_x$ , $LIN_x$ and GND	-0.3	15	V
$V_{T/SD/OD}$	Open-drain voltage	-0.3	15	V
$dV_{out}/dt$	Allowed output slew rate		50	V/ns

**Table 4. Total system**

Symbol	Parameter	Value	Unit
$V_{ISO}$	Isolation withstand voltage applied to each pin and heatsink plate (AC voltage, $t = 60\text{ s}$ )	1500	Vrms
$T_J$	Power chip operating junction temperature	-40 to 150	°C
$T_C$	Module case operation temperature	-40 to 125	°C

## 2.2 Thermal data

**Table 5. Thermal data**

Symbol	Parameter	Value	Unit
$R_{th(j-c)}$	Thermal resistance junction-case single IGBT	10	°C/W
	Thermal resistance junction-case single diode	15	
$R_{th(j-a)}$	Thermal resistance junction-ambient	44	

### 3 Electrical characteristics

$T_J = 25\text{ °C}$  unless otherwise noted.

#### 3.1 Inverter part

**Table 6. Static**

Symbol	Parameter	Test conditions	Min.	Typ.	Max.	Unit
$I_{CES}$	Collector cut-off current ( $V_{IN}^{(1)} = 0$ "logic state")	$V_{CE} = 550\text{ V}$ , $V_{CC} = V_{Boot} = 15\text{ V}$	-		250	$\mu\text{A}$
$V_{CE(sat)}$	Collector-emitter saturation voltage	$V_{CC} = V_{boot} = 15\text{ V}$ , $V_{IN}^{(1)} = 0$ to $5\text{ V}$ , $I_C = 1\text{ A}$	-	2.15	2.6	V
$V_F$	Diode forward voltage	$V_{IN}^{(1)} = 0$ "logic state", $I_C = 1\text{ A}$	-	1.35	1.7	V

1. Applied among  $HIN_x$ ,  $LIN_x$  and  $G_{ND}$  for  $x = U, V, W$ .

**Table 7. Inductive load switching time and energy**

Symbol	Parameter	Test conditions	Min.	Typ.	Max.	Unit
$t_{on}^{(1)}$	Turn-on time	$V_{DD} = 300\text{ V}$ , $V_{CC} = V_{boot} = 15\text{ V}$ , $V_{IN}^{(2)} = 0$ to $5\text{ V}$ , $I_C = 1\text{ A}$ (see <a href="#">Figure 5. Switching time definition</a> )	-	158	-	ns
$t_{c(on)}^{(1)}$	Crossover time (on)		-	60	-	
$t_{off}^{(1)}$	Turn-off time		-	515	-	
$t_{c(off)}^{(1)}$	Crossover time (off)		-	85	-	
$t_{rr}$	Reverse recovery time		-	82	-	
$E_{on}$	Turn-on switching energy		-	16	-	$\mu\text{J}$
$E_{off}$	Turn-off switching energy		-	10	-	

1.  $t_{ON}$  and  $t_{OFF}$  include the propagation delay time of the internal drive.  $t_{C(ON)}$  and  $t_{C(OFF)}$  are the switching times of the IGBT itself under the internally given gate driving conditions.

2. Applied among  $HIN_x$ ,  $LIN_x$  and  $G_{ND}$  for  $x = U, V, W$ .

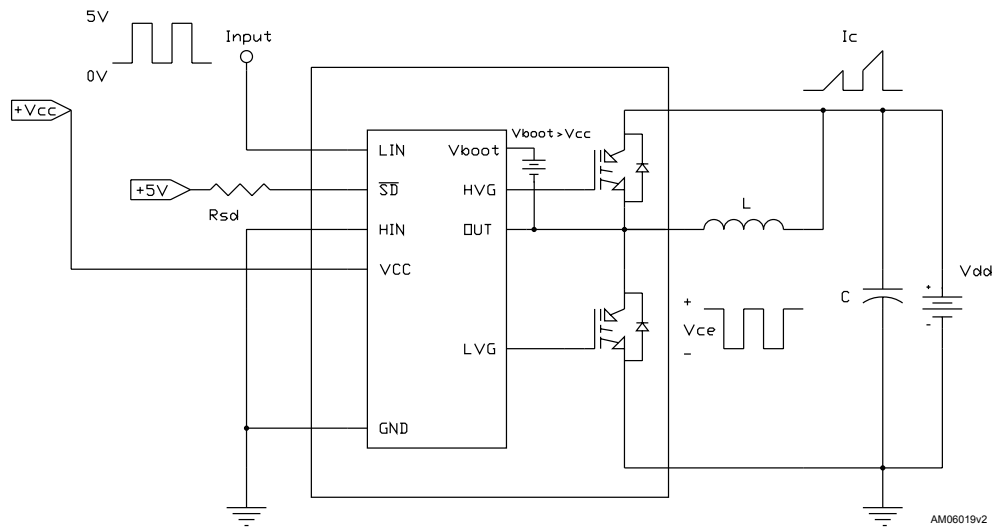
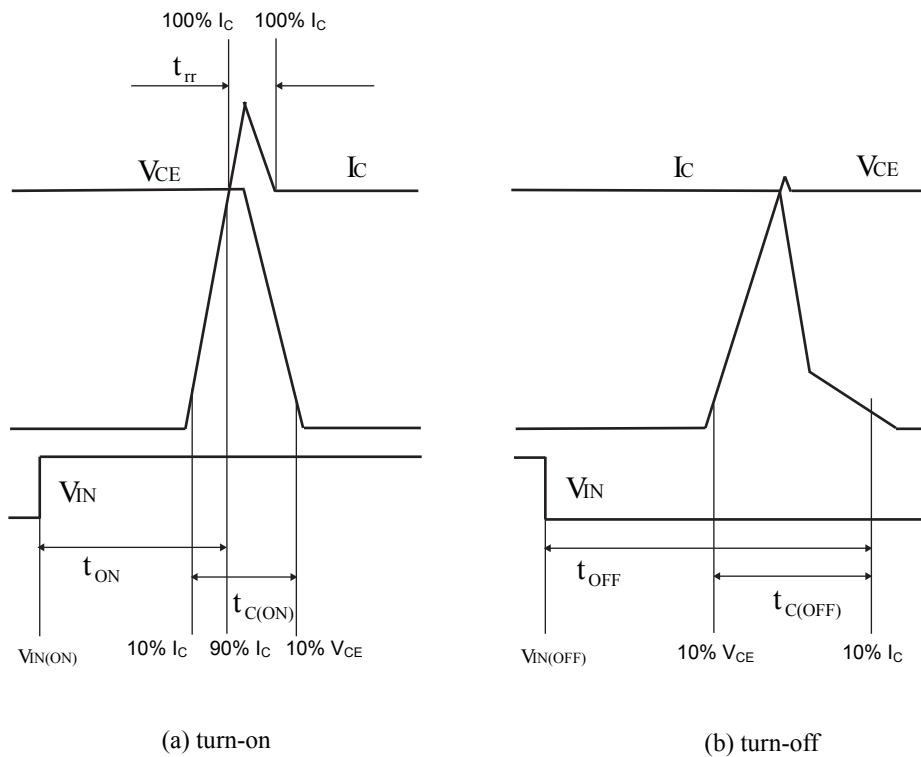
**Figure 4. Switching time test circuit**

**Figure 5. Switching time definition**

AM09223V1

Figure 5. Switching time definition refers to HIN, LIN inputs (active high).



### 3.2 Control part

**Table 8. Low-voltage power supply**

Symbol	Parameter	Test conditions	Min.	Typ.	Max.	Unit
$V_{CC\_hys}$	$V_{CC}$ UV hysteresis		1.2	1.5	1.8	V
$V_{CC\_thON}$	$V_{CC}$ UV turn-ON threshold		11.5	12	12.5	V
$V_{CC\_thOFF}$	$V_{CC}$ UV turn-OFF threshold		10	10.5	11	V
$I_{qccu}$	Undervoltage quiescent supply current	$V_{CC} = 10\text{ V}$ , $T/\overline{SD}/OD = 5\text{ V}$ , $LIN = HIN = CIN = 0\text{ V}$			150	$\mu\text{A}$
$I_{qcc}$	Quiescent current	$V_{CC} = 15\text{ V}$ , $T/\overline{SD}/OD = 5\text{ V}$ , $LIN = HIN = CIN = 0\text{ V}$			1	mA
$V_{ref}$	Internal comparator (CIN) reference voltage		0.51	0.54	0.56	V

**Table 9. Bootstrapped voltage**

Symbol	Parameter	Test conditions	Min.	Typ.	Max.	Unit
$V_{BS\_hys}$	$V_{BS}$ UV hysteresis		1.2	1.5	1.8	V
$V_{BS\_thON}$	$V_{BS}$ UV turn-ON threshold		11.1	11.5	12.1	V
$V_{BS\_thOFF}$	$V_{BS}$ UV turn-OFF threshold		9.8	10	10.6	V
$I_{QBSU}$	Undervoltage $V_{BS}$ quiescent current	$V_{BS} < 9\text{ V}$ , $T/\overline{SD}/OD = 5\text{ V}$ , $LIN = 0\text{ V}$ and $HIN = 5\text{ V}$ , $CIN = 0\text{ V}$		70	110	$\mu\text{A}$
$I_{QBS}$	$V_{BS}$ quiescent current	$V_{BS} = 15\text{ V}$ , $T/\overline{SD}/OD = 5\text{ V}$ , $LIN = 0\text{ V}$ and $HIN = 5\text{ V}$ , $CIN = 0$		150	210	$\mu\text{A}$
$R_{DS(on)}$	Bootstrap driver on-resistance	LVG ON		120		$\Omega$

**Table 10. Logic inputs**

Symbol	Parameter	Test conditions	Min.	Typ.	Max.	Unit
$V_{il}$	Low logic level voltage				0.8	V
$V_{ih}$	High logic level voltage		2.25			V
$I_{HINh}$	HIN logic "1" input bias current	$HIN = 15\text{ V}$	20	40	100	$\mu\text{A}$
$I_{HINl}$	HIN logic "0" input bias current	$HIN = 0\text{ V}$			1	$\mu\text{A}$
$I_{LINl}$	LIN logic "0" input bias current	$LIN = 0\text{ V}$			1	$\mu\text{A}$
$I_{LINh}$	LIN logic "1" input bias current	$LIN = 15\text{ V}$	20	40	100	$\mu\text{A}$
$I_{SDh}$	$\overline{SD}$ logic "0" input bias current	$\overline{SD} = 15\text{ V}$	20	120	300	$\mu\text{A}$
$I_{SDl}$	$\overline{SD}$ logic "1" input bias current	$\overline{SD} = 0\text{ V}$			3	$\mu\text{A}$
Dt	Dead time	See Figure 6. Dead time and interlocking waveform definitions		180		ns

**Table 11. Op-amp characteristics**

Symbol	Parameter	Test conditions	Min.	Typ.	Max.	Unit
$V_{io}$	Input offset voltage	$V_{ic} = 0\text{ V}, V_o = 7.5\text{ V}$			6	mV
$I_{io}$	Input offset current	$V_{ic} = 0\text{ V}, V_o = 7.5\text{ V}$		4	40	nA
$I_{ib}$	Input bias current <sup>(1)</sup>			100	200	nA
$V_{OL}$	Low/level output voltage	$R_L = 10\text{ k}\Omega$ to $V_{CC}$		75	150	mV
$V_{OH}$	High/level output voltage	$R_L = 10\text{ k}\Omega$ to GND	14	14.7		V
$I_o$	Output short-circuit current	Source, $V_{id} = +1\text{ V}; V_o = 0\text{ V}$	16	30		mA
		Sink, $V_{id} = -1\text{ V}; V_o = V_{CC}$	50	80		mA
SR	Slew rate	$V_i = 1 - 4\text{ V}; C_L = 100\text{ pF};$ unity gain	2.5	3.8		V/ $\mu$ s
GBWP	Gain bandwidth product	$V_o = 7.5\text{ V}$	8	12		MHz
$A_{vd}$	Large signal voltage gain	$R_L = 2\text{ k}\Omega$	70	85		dB
SVR	Supply voltage rejection ratio	vs $V_{CC}$	60	75		dB
CMRR	Common mode rejection ratio		55	70		dB

1. The direction of input current is out of the IC.

**Table 12. Sense comparator characteristics**

Symbol	Parameter	Test conditions	Min.	Typ.	Max.	Unit
$I_{ib}$	Input bias current	$V_{CIN} = 1\text{ V}$	-		1	$\mu$ A
$V_{od}$	Open-drain low level output voltage	$I_{od} = 3\text{ mA}$	-		0.5	V
$R_{ON\_OD}$	Open-drain low level output	$I_{od} = 3\text{ mA}$	-	166		$\Omega$
$R_{PD\_SD}$	$\overline{SD}$ pull-down resistor <sup>(1)</sup>		-	125		k $\Omega$
$t_{d\_comp}$	Comparator delay	T/ $\overline{SD}$ /OD pulled to 5 V through 100 k $\Omega$ resistor	-	90	130	ns
SR	Slew rate	$C_L = 180\text{ pF}, R_{pu} = 5\text{ k}\Omega$	-	60		V/ $\mu$ s
$t_{sd}$	Shutdown to high-/low-side driver propagation delay	$V_{OUT} = 0, V_{boot} = V_{CC}, V_{IN} = 0$ to 3.3 V	-	125		ns
$t_{isd}$	Comparator triggering to high-/low-side driver turn-off propagation delay	Measured applying a voltage step from 0 V to 3.3 V to pin CIN	-	200		

1. Equivalent values as a result of the resistances of three drivers in parallel.

**Table 13. Truth table**

Conditions	Logic input ( $V_I$ )			Output	
	T/ $\overline{\text{SD}}$ /OD	LIN	HIN	LVG	HVG
Shutdown enable half-bridge tri-state	L	X <sup>(1)</sup>	X <sup>(1)</sup>	L	L
Interlocking half-bridge tri-state	H	H	H	L	L
0 "logic state" half-bridge tri-state	H	L	L	L	L
1 "logic state" low-side direct driving	H	H	L	H	L
1 "logic state" high-side direct driving	H	L	H	L	H

1. X: don't care.

### 3.3 Waveform definitions

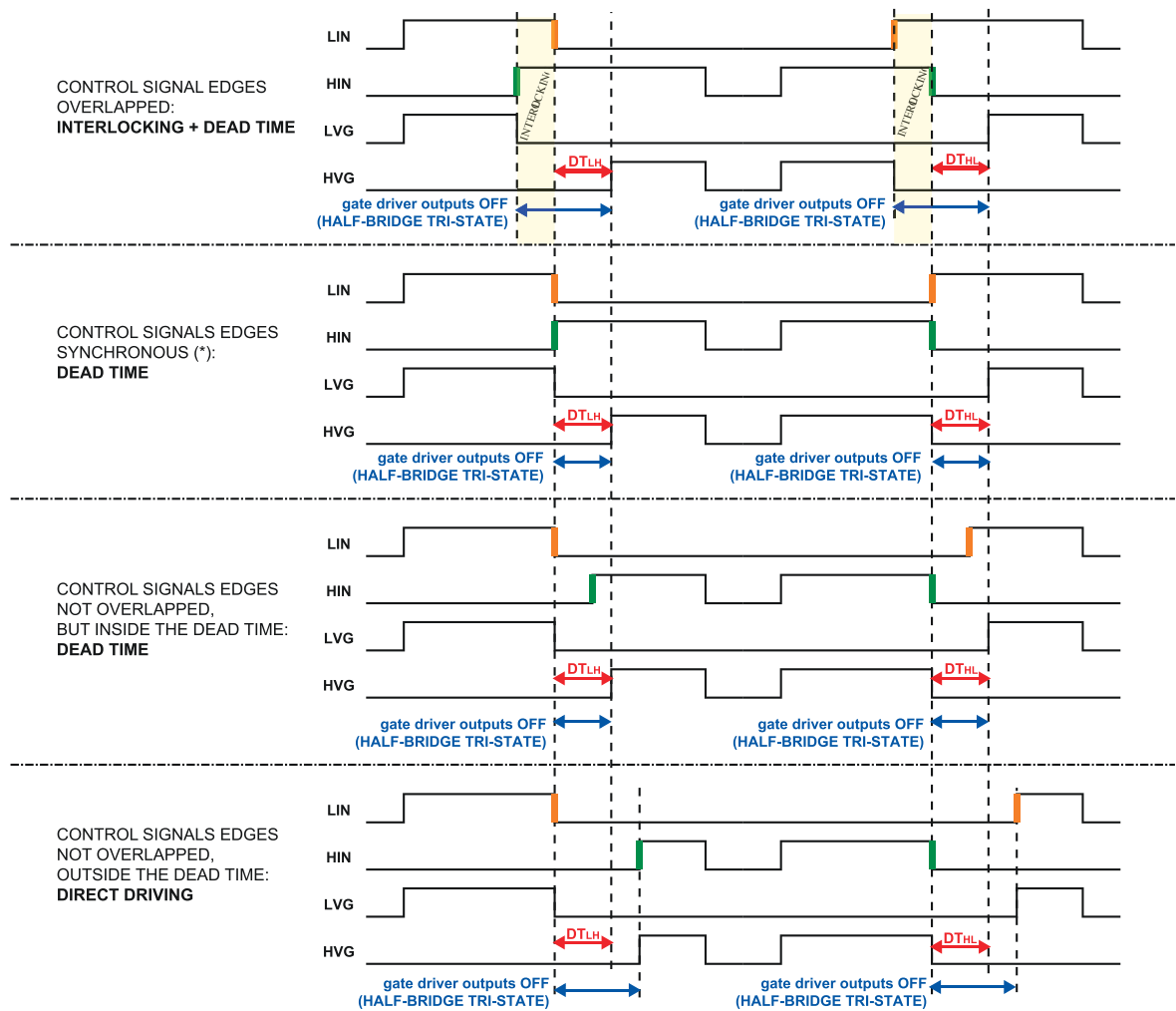
**Figure 6. Dead time and interlocking waveform definitions**

## 4 Shutdown function

The device is equipped with three half-bridge IC gate drivers and integrates a comparator for fault detection. The comparator has an internal voltage reference  $V_{REF}$  connected to the inverting input, while the non-inverting input pin (CIN) can be connected to an external shunt resistor for current monitoring.

Since the comparator is embedded in the U IC gate driver, in case of fault it disables directly the U outputs, whereas the shutdown of V and W IC gate drivers depends on the RC value of the external SD circuitry, which fixes the disabling time.

For an effective design of the shutdown circuit, please refer to Application note AN4966.

**Figure 7. Shutdown timing waveforms**

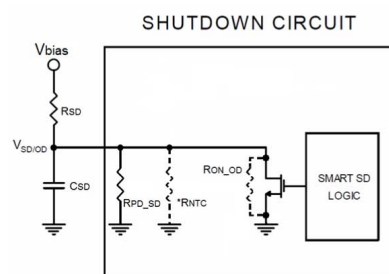
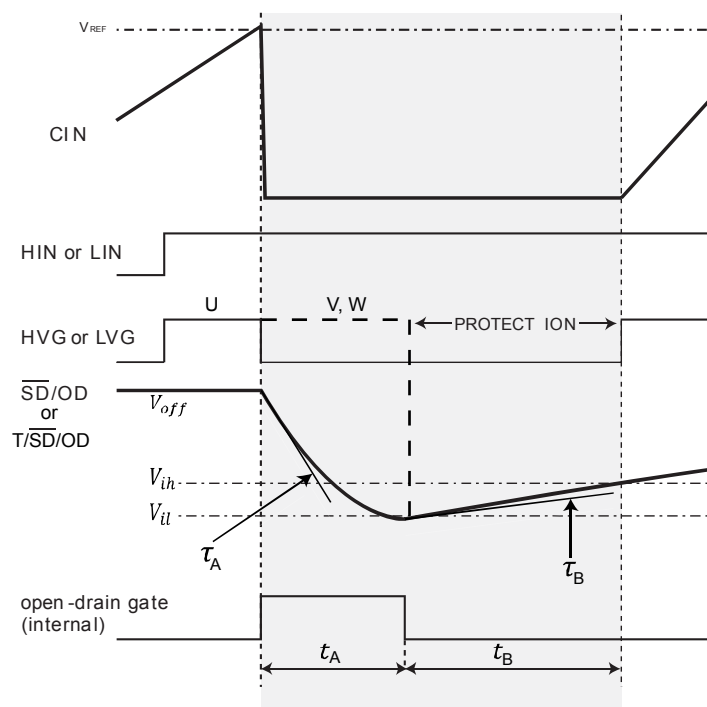

$$t_A \cong \tau_A \cdot \ln \left( \frac{V_{off} - V_{on}}{V_{il} - V_{on}} \right), \quad t_B \cong \tau_B \cdot \ln \left( \frac{V_{il} - V_{off}}{V_{ih} - V_{off}} \right)$$

$$\tau_A = (R_{ON\_OD} // R_{SD} // R_{PD\_SD} // R_{NTC}) \cdot C_{SD} \cong R_{ON\_OD} \cdot C_{SD}$$

$$\tau_B = (R_{SD} // R_{PD\_SD} // R_{NTC}) \cdot C_{SD}$$

$$V_{on} = \frac{R_{ON\_OD} // R_{PD\_OD} // R_{NTC}}{(R_{ON\_OD} // R_{PD\_OD} // R_{NTC}) + R_{SD}} \cdot V_{bias}$$

$$\cong \frac{R_{ON\_OD}}{R_{ON\_OD} + R_{SD}} \cdot V_{bias}$$

$$V_{off} = \frac{R_{PD\_OD} // R_{NTC}}{(R_{PD\_OD} // R_{NTC}) + R_{SD}} \cdot V_{bias}$$

$R_{SD}$  and  $C_{SD}$  external circuitry must be designed to ensure  $V_{on} < V_{il}$  &  $V_{off} > V_{ih}$

Please refer to AN4966 for further details.

\*  $R_{NTC}$  to be considered only when the NTC is internally connected to the T/SD/OD pin.

GADG250120171515FSR

## 5 Application circuit example

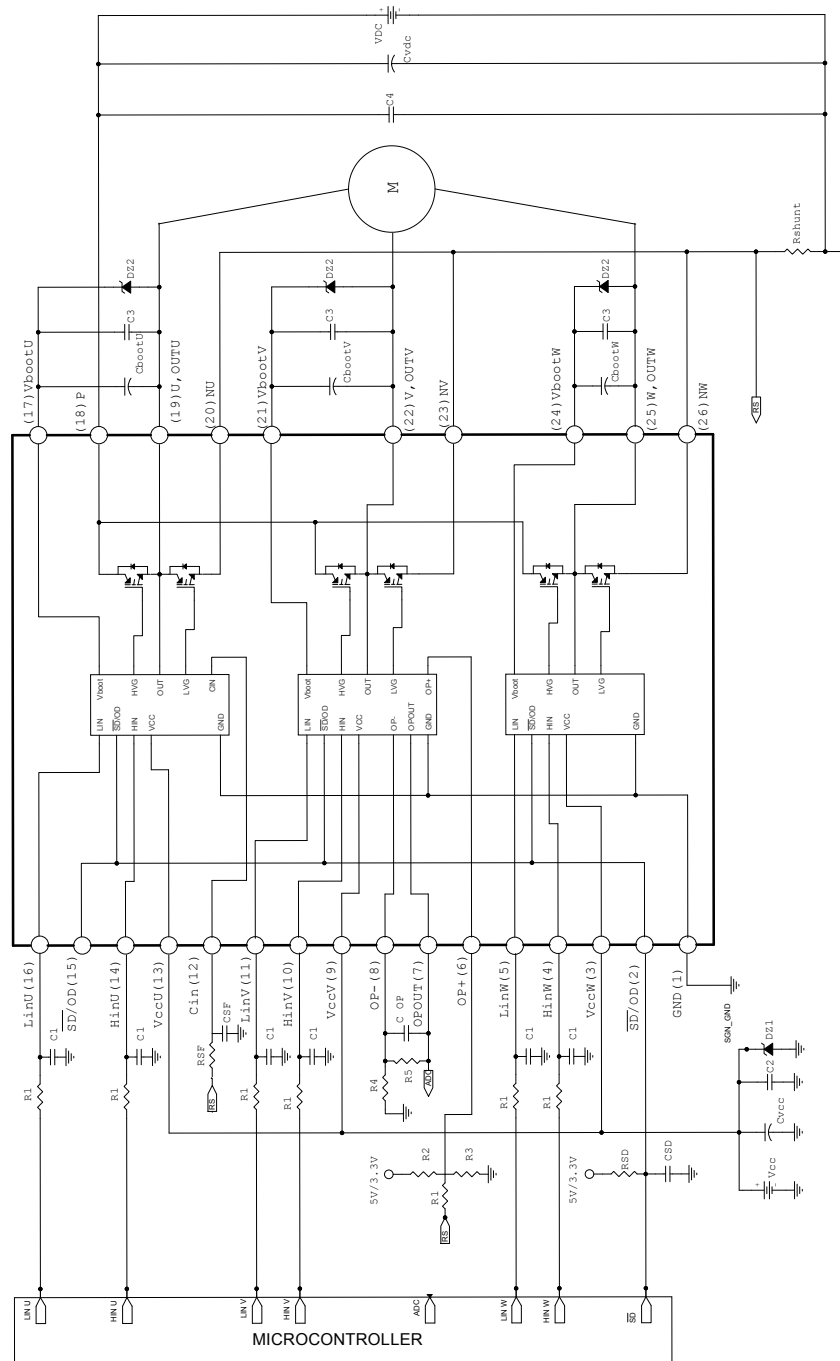
**Figure 8. Application circuit example**

ADG090820161407MT

Application designers are free to use a different scheme according to the specifications of the device.

## 5.1 Guidelines

- Input signals HIN, LIN are active high logic. A 375 kΩ (typ.) pull-down resistor is built-in for each input. To avoid input signal oscillation, the wiring of each input should be as short as possible, and the use of RC filters ( $R_1$ ,  $C_1$ ) on each input signal is suggested. The filters should be with a time constant of about 100 ns and placed as close as possible to the IPM input pins.
- The use of a bypass capacitor  $C_{VCC}$  (aluminum or tantalum) can reduce the transient circuit demand on the power supply. Also, to reduce any high-frequency switching noise distributed on the power lines, a decoupling capacitor  $C_2$  (100 to 220 nF, with low ESR and low ESL) should be placed as close as possible to the Vcc pin and in parallel with the bypass capacitor.
- The use of an RC filter ( $R_{SF}$ ,  $C_{SF}$ ) is recommended to prevent protection circuit malfunction. The time constant ( $R_{SF} \times C_{SF}$ ) should be set to 1 μs and the filter must be placed as close as possible to the  $C_{IN}$  pin.
- The  $\overline{SD}$  is an input/output pin (open-drain type if it is used as output). A built-in thermistor NTC is internally connected between the  $\overline{SD}$  pin and GND. The voltage  $V_{SD-GND}$  decreases as the temperature increases, due to the pull-up resistor  $R_{SD}$ . In order to keep the voltage always higher than the high-level logic threshold, the pull-up resistor should be set to 1 kΩ or 2.2 kΩ for 3.3 V or 5 V MCU power supply, respectively. The  $C_{SD}$  capacitor of the filter on  $\overline{SD}$  should be fixed no higher than 3.3 nF in order to assure the  $\overline{SD}$  activation time  $t_A \leq 500$  ns. Besides, the filter should be placed as close as possible to the  $\overline{SD}$  pin.
- The decoupling capacitor  $C_3$  (from 100 to 220 nF, ceramic with low ESR and low ESL), in parallel with each  $C_{boot}$ , filters high-frequency disturbance. Both  $C_{boot}$  and  $C_3$  (if present) should be placed as close as possible to the U, V, W and  $V_{boot}$  pins. Bootstrap negative electrodes should be connected to U, V, W terminals directly and separated from the main output wires.
- To avoid overvoltage on the Vcc pin, a Zener diode (Dz1) can be used. Similarly on the  $V_{boot}$  pin, a Zener diode (Dz2) can be placed in parallel with each  $C_{boot}$ .
- The use of the decoupling capacitor  $C_4$  (100 to 220 nF, with low ESR and low ESL) in parallel with the electrolytic capacitor  $C_{vdc}$  is useful to prevent surge destruction. Both capacitors  $C_4$  and  $C_{vdc}$  should be placed as close as possible to the IPM ( $C_4$  has priority over  $C_{vdc}$ ).
- By integrating an application-specific type HVIC inside the module, direct coupling to the MCU terminals without an optocoupler is possible.
- Low-inductance shunt resistors have to be used for phase leg current sensing.
- In order to avoid malfunctions, the wiring on N pins, the shunt resistor and  $P_{WR\_GND}$  should be as short as possible.
- The connection of  $SGN\_GND$  to  $PWR\_GND$  on one point only (close to the shunt resistor terminal) can reduce the impact of power ground fluctuation.

These guidelines ensure the specifications of the device for application designs. For further details, please refer to the relevant application note.

**Table 14. Recommended operating conditions**

Symbol	Parameter	Test conditions	Min.	Typ.	Max.	Unit
$V_{PN}$	Supply voltage	Applied among P-Nu, Nv, Nw		300	500	V
$V_{CC}$	Control supply voltage	Applied to $V_{CC-GND}$	13.5	15	18	V
$V_{BS}$	High-side bias voltage	Applied to $V_{BOOTx-OUT}$ for x = U, V, W	13		18	V
$t_{dead}$	Blanking time to prevent arm-short	For each input signal	1			μs
$f_{PWM}$	PWM input signal	-40 °C < $T_C$ < 100 °C -40 °C < $T_J$ < 125 °C			25	kHz
$T_C$	Case operation temperature				100	°C

## 6 Electrical characteristics (curves)

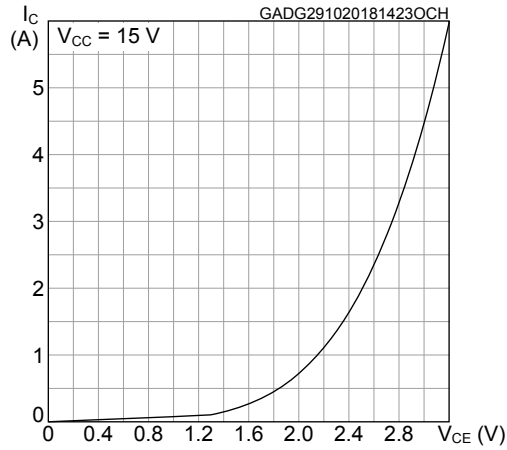
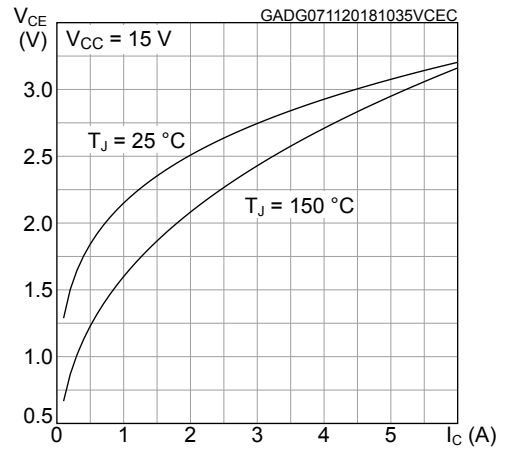
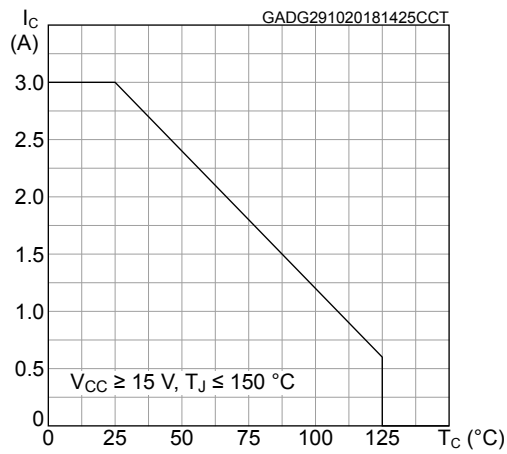
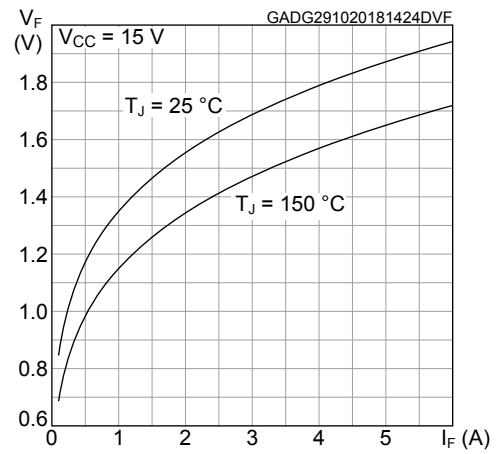
**Figure 9. Output characteristics**

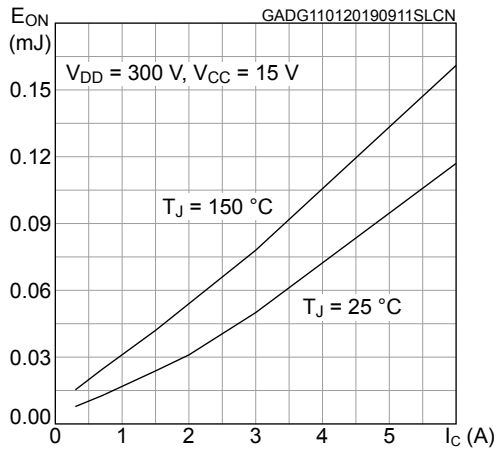
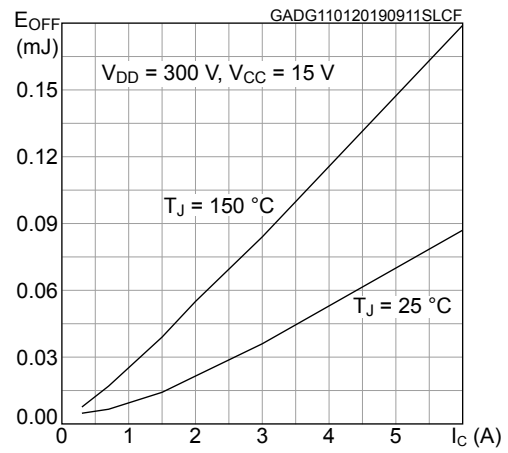
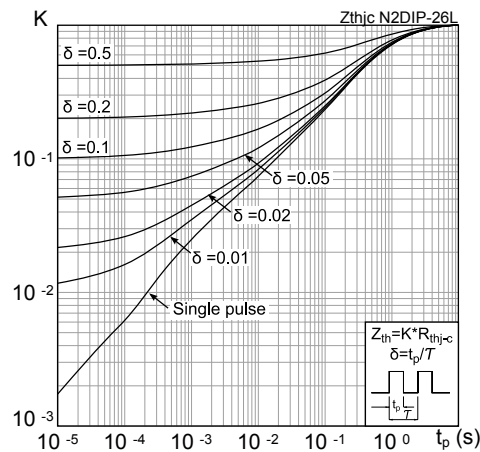
**Figure 10.  $V_{ce(sat)}$  vs collector current**

**Figure 11.  $I_C$  vs case temperature**

**Figure 12. Diode  $V_F$  vs forward current**

**Figure 13.  $E_{on}$  switching energy vs collector current**

**Figure 14.  $E_{off}$  switching energy vs collector current**

**Figure 15. Thermal impedance for IGBT**



## 7 Package information

In order to meet environmental requirements, ST offers these devices in different grades of **ECOPACK<sup>®</sup>** packages, depending on their level of environmental compliance. ECOPACK<sup>®</sup> specifications, grade definitions and product status are available at: [www.st.com](http://www.st.com). ECOPACK<sup>®</sup> is an ST trademark.

### 7.1 N2DIP-26L type L package information

Figure 16. N2DIP-26L type L package outline

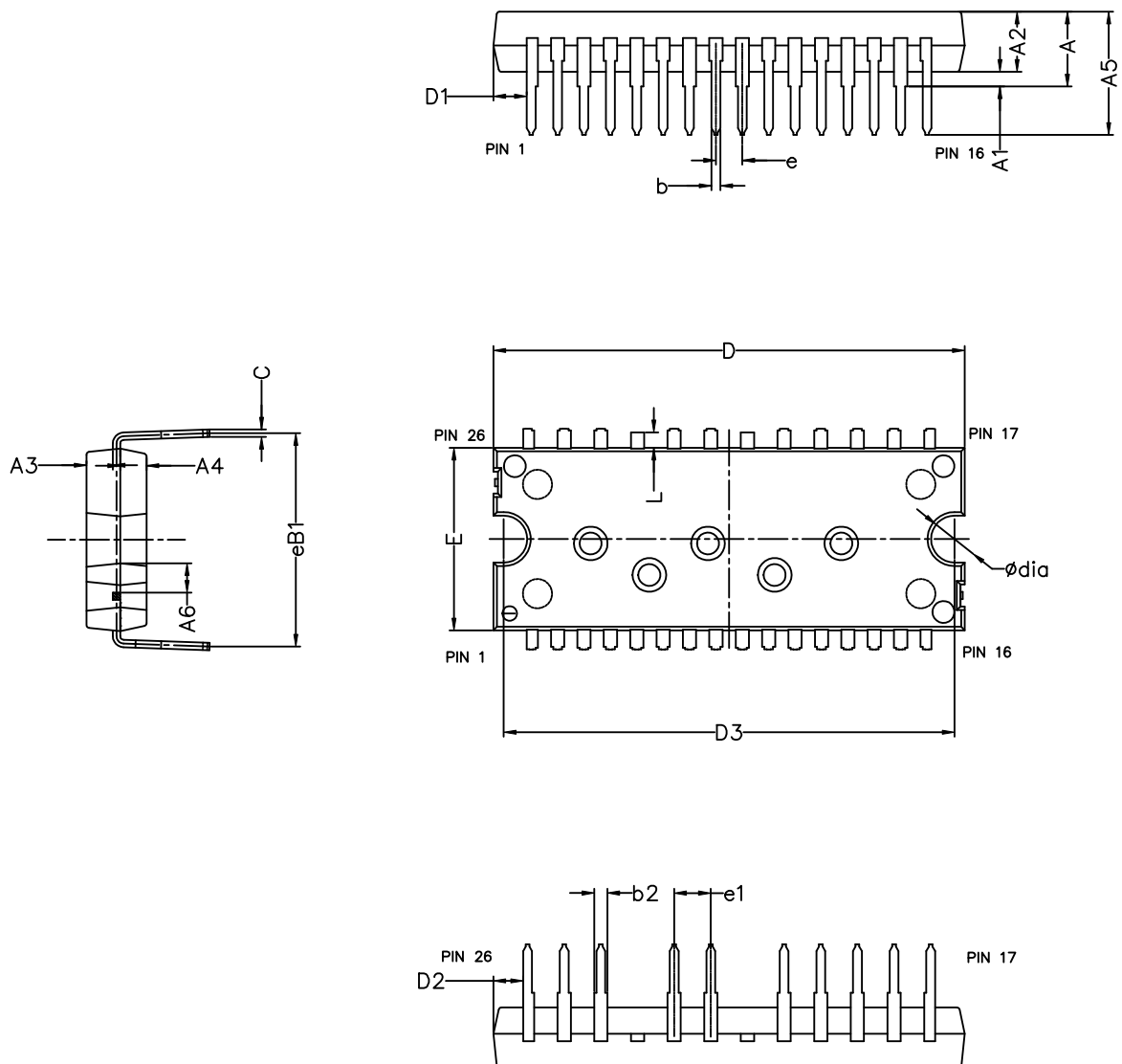

8558322\_typeL\_rev3

**Table 15. N2DIP-26L type L mechanical data**

Dim.	mm		
	Min.	Typ.	Max.
A	4.80	5.10	5.40
A1	0.80	1.00	1.20
A2	4.00	4.10	4.20
A3	1.70	1.80	1.90
A4	1.70	1.80	1.90
A5	8.10	8.40	8.70
A6	1.75		
b	0.53		0.72
b2	0.83		1.02
c	0.46		0.59
D	32.05	32.15	32.25
D1	2.10		
D2	1.85		
D3	30.65	30.75	30.85
E	12.35	12.45	12.55
e	1.70	1.80	1.90
e1	2.40	2.50	2.60
eB1	14.25	14.55	14.85
L	0.85	1.05	1.25
Dia	3.10	3.20	3.30

## 7.2 N2DIP-26L type Z package information

Figure 17. N2DIP-26L type Z package outline

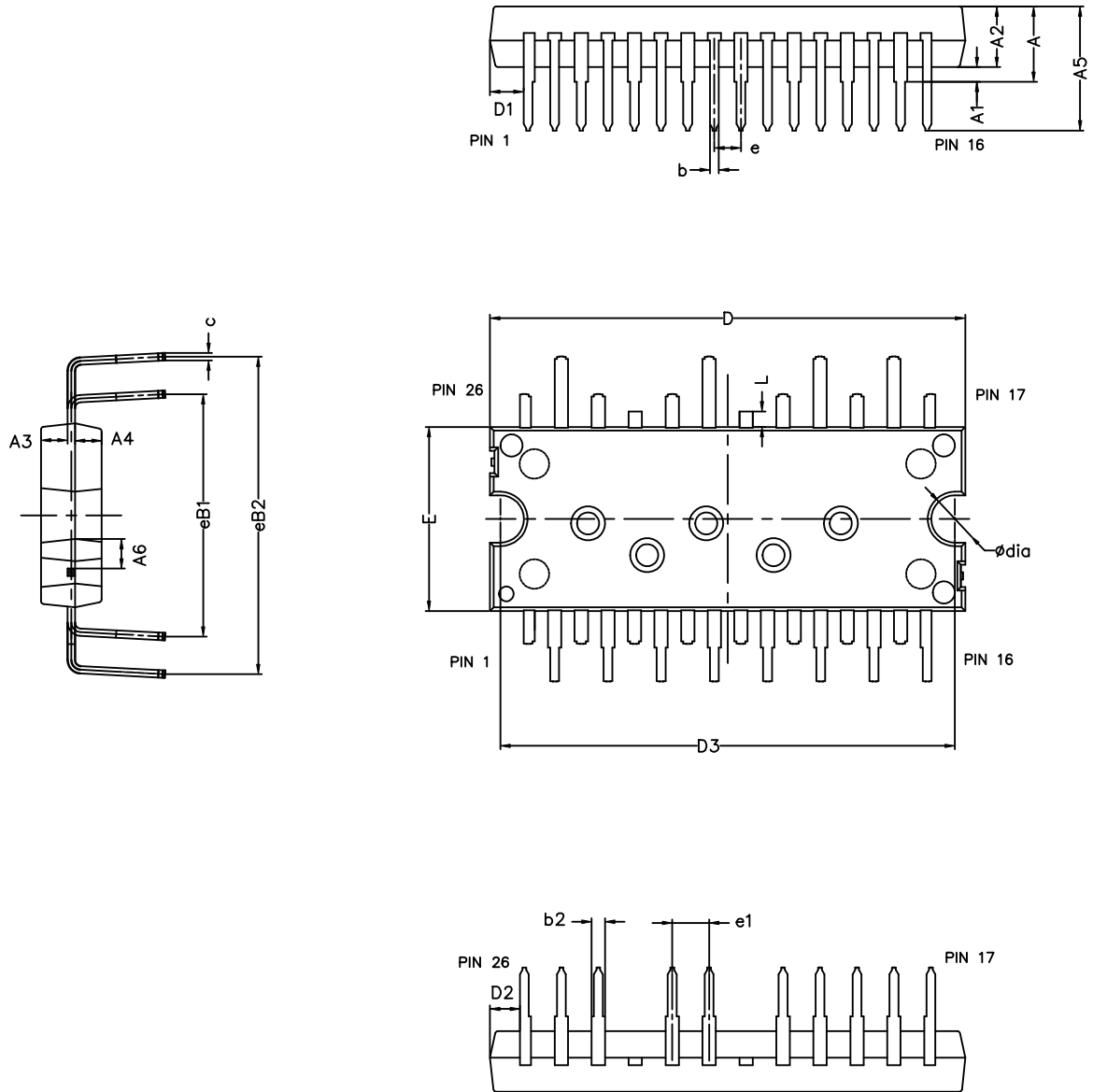

8558322\_typeZ\_rev3

**Table 16. N2DIP-26L type Z mechanical data**

Dim.	mm		
	Min.	Typ.	Max.
A	4.80	5.10	5.40
A1	0.80	1.00	1.20
A2	4.00	4.10	4.20
A3	1.70	1.80	1.90
A4	1.70	1.80	1.90
A5	8.10	8.40	8.70
A6	1.75		
b	0.53		0.72
b2	0.83		1.02
c	0.46		0.59
D	32.05	32.15	32.25
D1	2.10		
D2	1.85		
D3	30.65	30.75	30.85
E	12.35	12.45	12.55
e	1.70	1.80	1.90
e1	2.40	2.50	2.60
eB1	16.10	16.40	16.70
eB2	21.18	21.48	21.78
L	0.85	1.05	1.25
Dia	3.10	3.20	3.30

### 7.3 N2DIP-26L packing information

Figure 18. N2DIP-26L tube (dimensions are in mm)

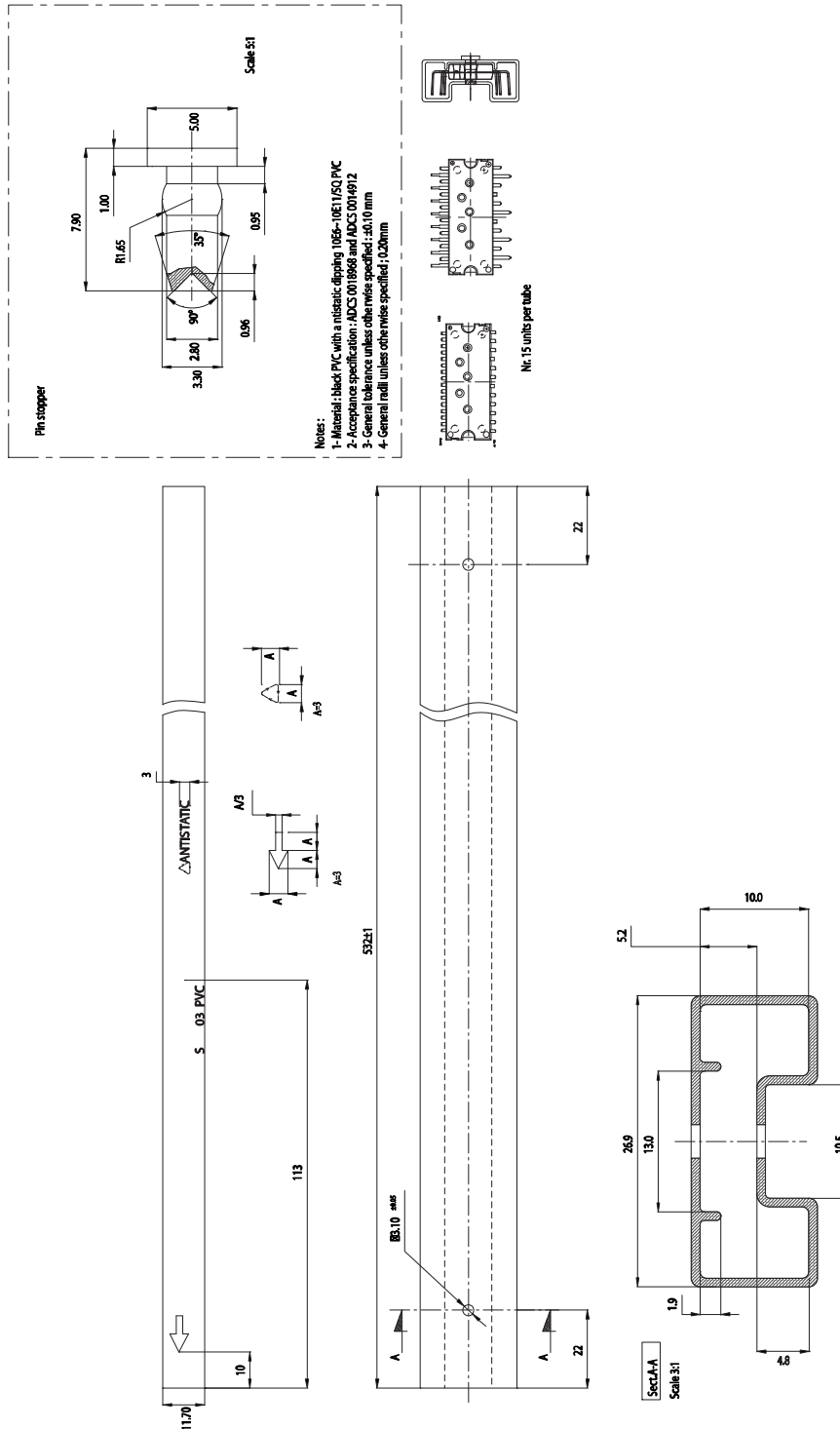

## Revision history

**Table 17. Document revision history**

Date	Revision	Changes
24-Nov-2016	1	Initial release.
09-Jun-2017	2	Modified features on cover page. Modified <i>Table 11: "Logic inputs (VCC = 15 V unless otherwise specified)"</i> . Updated <i>Section 6: "Package information"</i> . Minor text changes.
18-Jan-2019	3	Updated features and removed maturity status indication status on cover page. Updated <a href="#">Section 2.1 Absolute maximum ratings</a> , <a href="#">Section 3.1 Inverter part</a> , <a href="#">Section 4 Shutdown function</a> and <a href="#">Section 5.1 Guidelines</a> . Added <a href="#">Section 6 Electrical characteristics (curves)</a> . Minor text changes

## Contents

<b>1</b>	<b>Internal schematic diagram and pin configuration</b>	<b>2</b>
<b>2</b>	<b>Electrical ratings</b>	<b>5</b>
2.1	Absolute maximum ratings	5
2.2	Thermal data	5
<b>3</b>	<b>Electrical characteristics</b>	<b>7</b>
3.1	Inverter part	7
3.2	Control part	8
3.3	Waveform definitions	11
<b>4</b>	<b>Smart shutdown function</b>	<b>12</b>
<b>5</b>	<b>Application circuit example</b>	<b>13</b>
5.1	Guidelines	13
<b>6</b>	<b>Electrical characteristics (curves)</b>	<b>15</b>
<b>7</b>	<b>Package information</b>	<b>17</b>
7.1	N2DIP-26L type L package information	17
7.2	N2DIP-26L type Z package information	18
7.3	N2DIP-26L packing information	20
	<b>Revision history</b>	<b>22</b>

**IMPORTANT NOTICE – PLEASE READ CAREFULLY**

STMicroelectronics NV and its subsidiaries (“ST”) reserve the right to make changes, corrections, enhancements, modifications, and improvements to ST products and/or to this document at any time without notice. Purchasers should obtain the latest relevant information on ST products before placing orders. ST products are sold pursuant to ST’s terms and conditions of sale in place at the time of order acknowledgement.

Purchasers are solely responsible for the choice, selection, and use of ST products and ST assumes no liability for application assistance or the design of Purchasers’ products.

No license, express or implied, to any intellectual property right is granted by ST herein.

Resale of ST products with provisions different from the information set forth herein shall void any warranty granted by ST for such product.

ST and the ST logo are trademarks of ST. All other product or service names are the property of their respective owners.

Information in this document supersedes and replaces information previously supplied in any prior versions of this document.

© 2019 STMicroelectronics – All rights reserved



## X-ON Electronics

Largest Supplier of Electrical and Electronic Components

*Click to view similar products for [IGBT Modules category](#):*

*Click to view products by [STMicroelectronics manufacturer](#):*

Other Similar products are found below :

[F3L400R07ME4\\_B22](#) [F4-50R07W2H3\\_B51](#) [FB15R06W1E3](#) [FB20R06W1E3\\_B11](#) [FD1000R33HE3-K](#) [FD400R12KE3](#) [FD400R33KF2C-K](#)  
[FD401R17KF6C\\_B2](#) [FD-DF80R12W1H3\\_B52](#) [FF200R06YE3](#) [FF300R12KE4\\_E](#) [FF450R12ME4P](#) [FF600R12IP4V](#) [FP15R12W2T4](#)  
[FP20R06W1E3](#) [FP50R12KT3](#) [FP75R07N2E4\\_B11](#) [FS10R12YE3](#) [FS150R07PE4](#) [FS150R12PT4](#) [FS200R12KT4R](#) [FS20R06W1E3\\_B11](#)  
[FS50R07N2E4\\_B11](#) [FZ1000R33HE3](#) [FZ1800R17KF4](#) [DD250S65K3](#) [DF1000R17IE4](#) [DF1000R17IE4D\\_B2](#) [DF1400R12IP4D](#)  
[DF200R12PT4\\_B6](#) [DF400R07PE4R\\_B6](#) [BSM75GB120DN2\\_E3223c-Se](#) [F3L300R12ME4\\_B22](#) [F3L75R07W2E3\\_B11](#) [F4-50R12KS4\\_B11](#)  
[F475R07W1H3B11ABOMA1](#) [FD1400R12IP4D](#) [FD200R12PT4\\_B6](#) [FD800R33KF2C-K](#) [FF150R12ME3G](#) [FF300R17KE3\\_S4](#)  
[FF300R17ME4\\_B11](#) [FF401R17KF6C\\_B2](#) [FF650R17IE4D\\_B2](#) [FF900R12IP4D](#) [FF900R12IP4DV](#) [FP50R07N2E4\\_B11](#) [FS100R07PE4](#)  
[FS150R07N3E4\\_B11](#) [FS150R17N3E4](#)