

Automotive low dropout linear voltage regulator with configurable output voltage having 200 mA current capability



SO-8

PowerSSO-12

Features

| | | |
|---------------------------------|--------------|-------------------------------|
| Max. supply voltage (load dump) | V_S | 40 V |
| Max. output voltage tolerance | ΔV_O | +/-2% |
| Output current | I_O | 200 mA |
| Quiescent current | I_{qn} | $\leq 1 \mu A$ ⁽¹⁾ |

1. Maximum value with regulator disabled

- AEC-Q100 qualified 
- Operating DC power supply voltage range from 2.15 V to 28 V
- Battery and post regulation operating modes are allowed
- Low dropout voltage
- Low quiescent current consumption
- User-selectable output voltage (0.8 V; 1.2 V; 1.5 V; 1.8 V; 2.5 V; 2.8 V; 3.3 V or 5 V)
- Output voltage precision $\pm 2\%$
- Enable input for enabling/disabling the voltage regulator
- Output voltage monitoring with reset output
- Negligible ESR effect on output voltage stability for load capacitor
- Programmable autonomous watchdog through external capacitor (L99VR01J only)
- Undervoltage lockout UVLO
- Fast output discharge
- Thermal shutdown and short-circuit current limitation
- Advanced thermal warning and output overvoltage diagnostic (L99VR01J only)
- Programmable short-circuit output current (L99VR01J only)
- Wide operating temperature range ($T_J = -40^\circ C$ to $175^\circ C$ L99VR01J only)
- Documentation available for customers that need support when dealing with ASIL requirements as per ISO 26262

Product status link

[L99VR01](#)

Description

L99VR01 is a low dropout linear voltage regulator designed for automotive applications available in SO-8 and in PowerSSO-12 packages. The LDO delivers up to 200 mA of load current and consumes as low as 1 μ A of quiescent current when the regulator is disabled. The input is 40 V tolerant to withstand load dump, while the operating input voltage range is between 2.15 V and 28 V. The L99VR01 can be configured, through SELx pins, to generate a fixed selectable output voltage (0.8 V; 1.2 V; 1.5 V; 1.8 V; 2.5 V; 2.8 V; 3.3 V or 5 V). High output voltage accuracy ($\pm 2\%$) is kept over wide temperature range, line and load variation. The L99VR01 features enable, reset, autonomous watchdog, advanced thermal warning, fast output discharge and IShort control (IShort control, autonomous watchdog and advanced thermal warning are available only for the L99VR01J). The regulator output current is internally limited so that the device is protected against short-circuit and overload, besides it features over temperature protection; the short current value is configurable by an external resistance in the L99VR01J version. The L99VR01 can operate both in post regulation, attached to a pre-regulated voltage or directly connected to battery.

1 Block diagram and pins description

Figure 1. Functional block diagram of L99VR01S

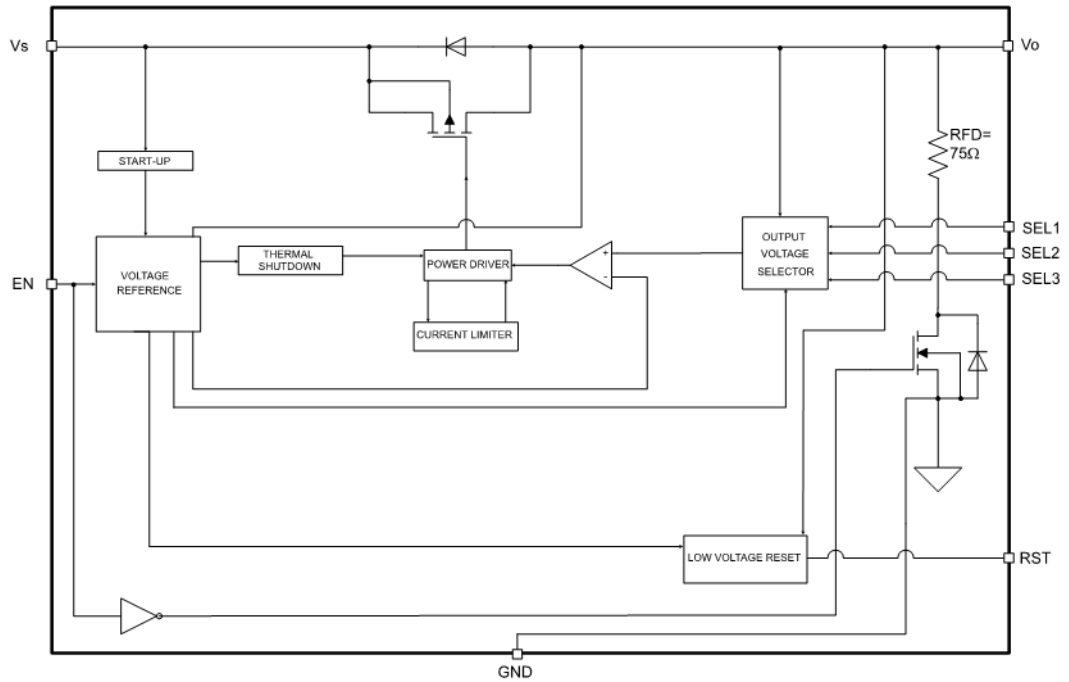
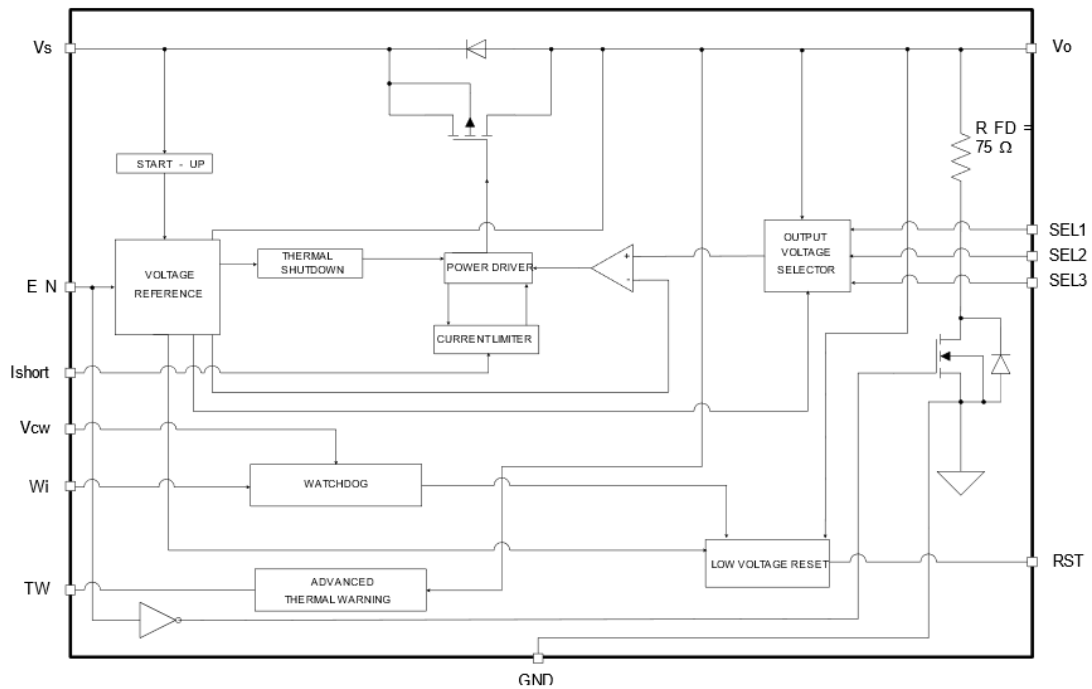
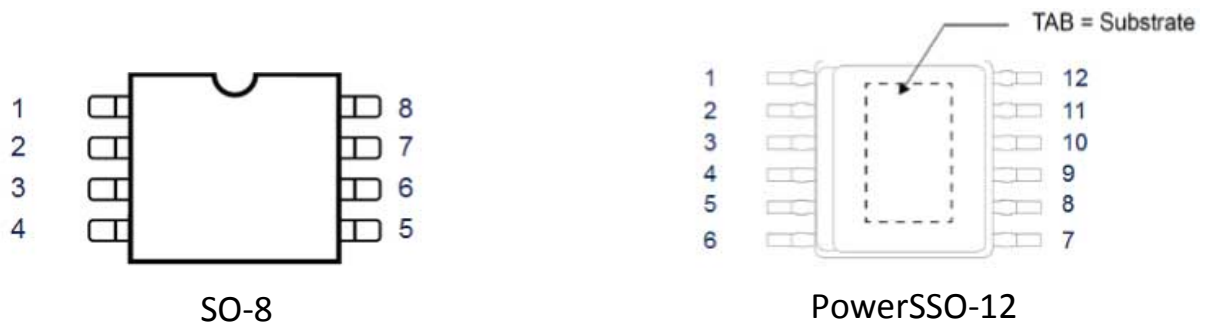

Figure 2. Functional block diagram of L99VR01J

Table 1. Pins description

| Pin name | SO-8 pin | PowerSSO-12 pin | Function |
|--------------------|----------|-----------------|--|
| V _S | 1 | 1 | Supply voltage. Block directly to ground with ceramic capacitor $\geq 4.7 \mu\text{F}$ and a 100 nF capacitor as close as possible to the pin |
| SEL1 | 2 | 2 | Output voltage selectors. |
| SEL2 | 3 | 3 | |
| SEL3 | 4 | 4 | |
| TW | | 5 | Advanced thermal warning output. If the device detects a junction temperature above the warning threshold, the pin is pulled low. If an overvoltage condition occurs, a square wave is provided through the TW output. Leave floating if not used. |
| I _{Short} | | 6 | Programmable short circuit output current input pin. A resistor between Ishort pin and GND sets the short circuit output current value. |
| EN | 5 | 7 | Enable input. With the Enable high, regulator, watchdog and reset are operating. With the Enable low, regulator, watchdog and reset are shutdown, while the fast discharge circuit is turned on. Connect the Enable to Vs to keep the device always enabled |
| GND | 6 | 8 | Ground reference. |
| V _{CW} | | 9 | Watchdog timer adjust. A capacitor between V _{CW} pin and GND sets the time response of the watchdog monitor (just for L99VR01J). |

| Pin name | SO-8 pin | PowerSSO-12 pin | Function |
|----------|----------|-----------------|--|
| Wi | | 10 | Watchdog refresh input. If the square wave frequency at this input pin is too low, a low pulse at RST pin is generated (just for L99VR01J). |
| RST | 7 | 11 | Reset output. It is pulled down when output voltage goes below V_{o_th} or frequency at Wi is too low (just for L99VR01J). Leave floating if not used. |
| V_O | 8 | 12 | Voltage regulator output. Block to ground with a capacitor $\geq 3.3 \mu F$ (needed for regulator stability). |
| TAB | | TAB | Connected to ground |

Figure 3. Pins configuration

2 Electrical specifications

2.1 Absolute maximum ratings

Stressing the device above the rating listed in the Table 2. Absolute maximum ratings may cause permanent damage to the device. These are stress ratings only and operation of the device at these or any other conditions above those indicated in the operating sections of this specification is not implied. Exposure to absolute maximum rating conditions for extended periods may affect device reliability.

Table 2. Absolute maximum ratings

| Symbol | Parameter | Value | Unit |
|----------------|---|----------------------|------|
| V_S | DC supply voltage | -0.3 to 28 | V |
| V_S | Single pulse / $t_{max} < 400$ ms "transient load dump" | 40 | V |
| I_S | Input current | internally limited | |
| V_O | DC output voltage | -0.3 to 6.7 | V |
| I_O | DC output current | internally limited | |
| V_{Wi} | Watchdog input voltage | -0.3 to $V_O + 0.3$ | V |
| V_{CW} | Watchdog delay voltage | - 0.3 to $V_O + 0.3$ | V |
| V_{rst} | Reset output voltage | -0.3 to $V_O + 0.3$ | V |
| I_{rst} | Reset output current | Internally limited | |
| V_{tw} | Thermal warning output voltage | -0.3 to $V_O + 0.3$ | V |
| I_{tw} | Thermal warning output current | Internally limited | |
| V_{sh_ctrl} | "Short current" control voltage | -0.3 to 3.6 | V |
| V_{EN} | Enable input | -0.3 to $V_S + 0.3$ | V |
| V_{SELx} | Selectors input voltage | -0.3 to $V_S + 0.3$ | V |
| VESD HBM | ESD HBM voltage level (HBM-MIL STD 883C) | ± 2 | kV |
| VESD CDM | ESD CDM voltage level (CDM AEC-Q100-011) | ± 500 | V |
| | ESD CDM voltage level on corner pins (CDM AEC-Q100-011) | ± 750 | V |

2.2 Thermal data

2.2.1 Thermal resistance

Table 3. Operation junction temperature

| Item | Symbol | Parameter | Value | | Unit |
|-------|----------------|--|-------------|------|------|
| | | | PowerSSO-12 | SO-8 | |
| A.001 | $R_{thj-case}$ | Thermal resistance junction to case | 8.5 | | °C/W |
| A.057 | $R_{thj-lead}$ | Thermal resistance junction to lead ⁽¹⁾ | | 54.5 | °C/W |
| A.002 | $R_{thj-amb}$ | Thermal resistance junction to ambient | 27.4 | 71 | °C/W |

1. Measured on V_s

Note: the values quoted are for PCB 77 mm x 86 mm x 1.6 mm, FR4, four layers; Cu thickness 0.070 mm (outer layers) . Cu thickness 0.035 mm (inner layers), Thermal vias separation 1.2 mm, Thermal via diameter 0.3 mm +/- 0.08 mm, Cu thickness on vias 0.025 mm.

2.2.2 Thermal protection

Table 4. Temperature threshold

| Item | Symbol | Parameter | | Test condition | Min. | Typ. | Max. | Unit |
|-------|-----------------------------|--------------------------------|--------------|----------------|------|------|------|------|
| A.003 | T_{prot_s} ⁽¹⁾ | Thermal protection temperature | | L99VR01S | 150 | | 180 | °C |
| A.004 | T_{prot_j} ⁽¹⁾ | Thermal protection temperature | | L99VR01J | 175 | | 200 | °C |
| A.005 | T_{prot_hyst} | Thermal protection hysteresis | | | | 11 | | °C |
| A.006 | T_J | Operating junction temperature | SO-8 | T_J | -40 | | 150 | °C |
| | | | Power-SSO-12 | | -40 | | 175 | |
| A.007 | T_{stg} | Storage temperature | | T_{stg} | | | 150 | °C |

1. Thermal protection is guaranteed by design and characterization.

2.3 Electrical characteristics

Values specified in this section are for $V_S = 2.15 \text{ V to } 18 \text{ V}$, $T_J = -40 \text{ }^\circ\text{C to } +150 \text{ }^\circ\text{C}$, unless otherwise stated.

Table 5. Electrical characteristics

| Item | Pin | Symbol | Parameter | | Test condition | Min. | Typ. | Max. | Unit |
|-------|------------|--------------------|--|----------|---|-------|------|-------|------|
| A.008 | V_O | V_O | Output voltage | | $V_S = 2.15 \text{ to } 18 \text{ V}$ $I_O = 1 \text{ to } 200 \text{ mA}$ $\text{SEL_CONF}=[0;0;0]$ | 0.784 | 0.8 | 0.816 | V |
| | | | | | $V_S = 2.15 \text{ to } 18 \text{ V}$ $I_O = 1 \text{ to } 200 \text{ mA}$ $\text{SEL_CONF}=[0;0;1]$ | 1.176 | 1.2 | 1.224 | |
| | | | | | $V_S = 2.15 \text{ to } 18 \text{ V}$ $I_O = 1 \text{ to } 200 \text{ mA}$ $\text{SEL_CONF}=[0;1;0]$ | 1.470 | 1.5 | 1.530 | |
| | | | | | $V_S = 2.45 \text{ to } 18 \text{ V}$ $I_O = 1 \text{ to } 200 \text{ mA}$ $\text{SEL_CONF}=[0;1;1]$ | 1.764 | 1.8 | 1.836 | |
| | | | | | $V_S = 3.15 \text{ to } 18 \text{ V}$ $I_O = 1 \text{ to } 200 \text{ mA}$ $\text{SEL_CONF}=[1;0;0]$ | 2.450 | 2.5 | 2.550 | |
| | | | | | $V_S = 3.45 \text{ to } 18 \text{ V}$ $I_O = 1 \text{ to } 200 \text{ mA}$ $\text{SEL_CONF}=[1;0;1]$ | 2.744 | 2.8 | 2.856 | |
| | | | | | $V_S = 3.95 \text{ to } 18 \text{ V}$ $I_O = 1$ to 200 mA $\text{SEL_CONF}=[1;1;0]$ | 3.234 | 3.3 | 3.366 | |
| | | | | | $V_S = 5.65 \text{ to } 18 \text{ V}$ $I_O = 1$ to 200 mA $\text{SEL_CONF}=[1;1;1]$ | 4.9 | 5 | 5.1 | |
| A.009 | V_O | I_O | DC output current | | $V_O=0.8 \text{ V}; 1.2 \text{ V}; 1.5 \text{ V};$ $1.8 \text{ V}; 2.5 \text{ V}; 2.8 \text{ V}; 3.3 \text{ V};$ 5 V | | | 200 | mA |
| A.010 | V_O | I_{short} | Short-circuit current lower value ⁽¹⁾ | L99VR01J | $V_S = 4 \text{ V}$ for $V_O=3.3 \text{ V}$ $V_S = 5.8 \text{ V}$ for $V_O=5 \text{ V}$ with I_{short} pin connected to GND | 30 | 65 | 100 | mA |
| A.011 | V_O | I_{short} | Short-circuit current upper value | L99VR01S | $V_S = 4 \text{ V}$ for $V_O=3.3 \text{ V}$ $V_S = 5.8 \text{ V}$ for $V_O=5 \text{ V}$ $I_{\text{short}} > I_O$ | 240 | 360 | 480 | mA |
| | | | | L99VR01J | $V_S = 4 \text{ V}$ for $V_O=3.3 \text{ V}$ $V_S = 5.8 \text{ V}$ for $V_O=5 \text{ V}$ with I_{short} pin floating; $I_{\text{short}} > I_O$ | | | | |
| A.012 | V_S, V_O | $\Delta V_O / V_O$ | Static line regulation | | V_S is from V_{S_low} ⁽²⁾ to 18 V; $I_O = 1 \text{ mA}; 100 \text{ mA};$ 200 mA $V_O=3.3 \text{ V}; V_O=5 \text{ V}$ | | | 1 | % |
| | | | Dynamic line regulation ⁽³⁾ | | V_S is from V_{S_low} ⁽²⁾ to 18 V; $T_r, f=1 \text{ ms}; I_O = 1 \text{ mA}; 50$ mA; 200 mA; $V_O = 3.3 \text{ V};$ $V_O=5 \text{ V}$ | | | 3 | % |

| Item | Pin | Symbol | Parameter | Test condition | Min. | Typ. | Max. | Unit |
|-------|---------------------------------|---------------------|--|---|------|-------------------|------|------|
| A.013 | V _O | $\Delta V_O / V_O$ | Static load regulation ⁽⁴⁾ | I _O = 1 mA to 100 mA V _O = 3.3 V for V _S = 5 V; V _O = 5 V for V _S = 6 V | | | 1 | % |
| | | | Dynamic load regulation ^{(3) (4)} | I _O = 10 mA to 100 mA, Tr, f = 10 μs V _O = 3.3 V for V _S = 5 V; V _O = 5 V for V _S = 6 V | | | 3 | % |
| A.014 | V _S , V _O | V _{dp} | Drop voltage ⁽⁵⁾ | I _O = 150 mA V _O = 5 V | | | 500 | mV |
| | | | | I _O = 150 mA V _O = 3.3 V | | | | |
| | | | | I _O = 150 mA V _O = 2.8 V | | | | |
| | | | | I _O = 150 mA V _O = 2.5 V | | | | |
| | | | | I _O = 150 mA V _O = 1.8 V | | | 530 | mV |
| | | | | I _O = 200 mA V _O = 5 V | | | | |
| | | | | I _O = 200 mA V _O = 3.3 V | | | | |
| | | | | I _O = 200 mA V _O = 2.8 V | | | | |
| | | | | I _O = 200 mA V _O = 2.5 V | | | | |
| | | | | I _O = 200 mA V _O = 1.8 V | | | | |
| A.015 | V _S , V _O | PSRR | Power supply rejection ratio | V _S = 13.5 V; V _O = 5 V; I _O = 200 mA fr = 1 kHz | | 75 ⁽³⁾ | | dB |
| A.017 | V _S , V _O | I _{qn} | Current consumption with regulator disabled I _{qn} = I _S – I _O | V _S = 3.5 V; 13.5 V, EN = low | | | 1 | μA |
| A.058 | V _S , V _O | I _{qn_LL} | Current consumption with regulator enabled I _{qn_LL} = I _S – I _O | V _S = 3.5 V; 13.5 V, I _O = 0 μA; EN = high | | 75 | 100 | μA |
| A.018 | V _S , V _O | I _{qn_O} | Current consumption with regulator enabled I _{qn_O} = I _S – I _O | V _S = 3.5 V; 13.5 V, 0 < I _O ≤ 100 μA; EN = high | | 100 | 130 | μA |
| A.019 | V _S , V _O | I _{qn_50} | Current consumption with regulator enabled I _{qn_50} = I _S – I _O | V _S = 3.5 V; 13.5 V, I _O = 50 mA EN = high | | 1 | 1.3 | mA |
| A.020 | V _S , V _O | I _{qn_100} | Current consumption with regulator enabled I _{qn_100} = I _S – I _O | V _S = 3.5 V; 13.5 V, I _O = 100 mA EN = high | | 1.7 | 2.0 | mA |
| A.021 | V _S , V _O | I _{qn_200} | Current consumption with regulator enabled I _{qn_200} = I _S – I _O | V _S = 3.5 V; 13.5 V, I _O = 200 mA EN = high | | 3.1 | 3.5 | mA |

| Item | Pin | Symbol | Parameter | Test condition | Min. | Typ. | Max. | Unit |
|-------|----------------|------------------------|-------------------------------|---|------|------|------|------|
| A.022 | V _S | V _{UVLO_fall} | Undervoltage lockout, falling | V _O = 0.8 V; 1.2 V; 1.5 V; 1.8 V | 1.5 | 1.6 | 1.7 | V |
| | | | | V _O = 2.5 V; 2.8 V; 3.3 V | 2.3 | 2.4 | 2.55 | |
| | | | | V _O = 5 V | 4.6 | 4.8 | 4.9 | |
| A.023 | V _S | V _{UVLO_rise} | Undervoltage lockout, rising | V _O = 0.8 V; 1.2 V; 1.5 V; 1.8 V | 1.7 | 1.8 | 2.1 | V |
| | | | | V _O = 2.5 V; 2.8 V; 3.3 V | 2.6 | 2.7 | 2.8 | |
| | | | | V _O = 5 V | 4.9 | 5.1 | 5.3 | |

1. *Short typical value of 120 mA for t = 400 μs during the power on*
2. *V_{S_Low} = 3.5 V @ V_O = 0.8 V, 1.2 V, 1.5 V, 1.8 V & 2.5 V; V_{S_Low} = 5 V @ V_O = 2.8 V & 3.3 V, V_{S_Low} = 6 V @ V_O = 5 V*
3. *Parameters are guaranteed by design*
4. *Referred to Figure 30. Maximum load variation response*
5. *Considering that the minimum operating input voltage is 2.15 V, the dropout voltage (V_{dp}) is not defined for output voltages below 1.8 V.*

Table 6. Fast output discharge

| Item | Pin | Symbol | Parameter | Test condition | Min. | Typ. | Max. | Unit |
|-------|----------------|-----------------|-------------------------------------|---|------|------|------|------|
| A.024 | V _O | R _{FD} | Fast discharge - pull down resistor | V _S = 3.95 V; 13.5 V; V _O = 3.3 V, V _O = 5 V EN = low | 50 | 75 | 105 | Ω |

Table 7. Reset

| Item | Pin | Symbol | Parameter | Test condition | Min. | Typ. | Max. | Unit |
|-------|-----|------------------------|---|---|-------|------|----------------------|----------------------|
| A.025 | RST | V _{rst_l} | Reset output low voltage | V _S = 5 V; 13.5 V R _{ext} ≥ 4.7 KΩ to V _O V _O = 3.3 V, V _O = 5 V | | | 0.2 x V _O | V |
| A.026 | RST | I _{rst_lkg} | Reset output high leakage current | V _{rst} = 0.8 V | | | 1 | μA |
| A.027 | RST | V _{O_th} | V _O out of regulation – low threshold | V _S = 5 V; 13.5 V V _O decreasing V _O = 3.3 V, V _O = 5 V | 13.5% | 10% | 6.5% | Below V _O |
| A.055 | RST | V _{O_th_hyst} | V _O out of regulation – low threshold hysteresis | V _S = 5 V; 13.5 V; V _O increasing; V _O = 3.3 V; V _O = 5 V | | 2% | | V _{O_th} |
| A.028 | RST | T _{rr} | Reset reaction time | V _S = 5 V; 13.5 V; V _O = 3.3 V; V _O = 5 V | 10 | 16 | 37 | μs |
| A.029 | RST | T _{rd} | Reset delay time | V _S = 5 V; 13.5 V; V _O = 3.3 V; V _O = 5 V | 160 | 250 | 300 | μs |

Table 8. Watchdog (only for L99VR01J)

| Item | Pin | Symbol | Parameter | Test condition | Min. | Typ. | Max. | Unit |
|-------|-----------------|--------------------|---|---|-------------------------|------|--------------------------|----------------|
| A.030 | W _i | V _{ih} | Input high voltage ⁽¹⁾ | V _S =5 V; 13.5 V V _O =3.3 V; V _O =5 V | 0.7 x V _O | | | V |
| A.031 | W _i | V _{il} | Input low voltage ⁽¹⁾ | V _S = 5 V; 13.5 V V _O =3.3 V; V _O =5 V | | | 0.25 x V _O | V |
| A.033 | W _i | I _{wi} | Pull down current | V _{wi} = 3.3 V | | 6 | 10 | μA |
| A.034 | V _{CW} | V _{wlth} | Low threshold | V _S = 5V; 13.5 V V _O =3.3V; V _O =5V | 10 % | 13 % | 16 % | V _O |
| A.035 | V _{CW} | V _{wth} | High threshold | V _S = 5V; 13.5 V V _O =3.3V; V _O =5V | 44 % | 47 % | 50 % | V _O |
| A.036 | V _{CW} | I _{CWc} | Charge current | V _S = 5V; 13.5 V V _{CW} = 0.1V V _O =3.3V; V _O =5V | 5 | 10 | 20 | μA |
| A.037 | V _{CW} | I _{CWd} | Discharge current | V _S = 5 V; 13.5 V V _{CW} = 2.5 V V _O =3.3 V; V _O =5 V | 1.25 | 2.5 | 5 | μA |
| A.040 | V _{CW} | I _{w_off} | Watchdog deactivation current threshold | V _S = 5 V; 13.5 V V _O =3.3 V; V _O =5 V | 0.6 | 1.05 | 1.5 | mA |
| A.041 | V _{CW} | I _{w_on} | Watchdog activation current threshold | V _S = 5 V; 13.5 V V _O =3.3 V; V _O =5 V | 2.2 | 3.35 | 4.5 | mA |

1. Watchdog input requires a square wave signal (duty cycle of 50 %)

Table 9. Enable

| Item | Pin | Symbol | Parameter | Test condition | Min. | Typ. | Max. | Unit |
|-------|-----|----------------------|-----------------------|-------------------------|------|------|------|------|
| A.042 | EN | V _{En_low} | EN input low voltage | | | | 0.6 | V |
| A.043 | EN | V _{En_high} | EN input high voltage | | 1.5 | | | V |
| A.045 | EN | I _{En} | Pull down current | V _S = 13.5 V | | 4 | 12 | μA |

Table 10. Output voltages selectors

| Item | Pin | Symbol | Parameter | Test condition | Min. | Typ. | Max. | Unit |
|-------|------|------------------------|-------------------------|-------------------------------|------|------|------|------|
| A.046 | SELx | V _{SELx_low} | SELx input low voltage | | | | 0.3 | V |
| A.047 | SELx | V _{SELx_high} | SELx input high voltage | | 0.7 | | | V |
| A.048 | SELx | I _{SELx} | Pull down current | V _S = 3.5V; 13.5 V | | 0.1 | 0.4 | μA |

Table 11. Thermal warning and protection (only for L99VR01J)

| Item | Pin | Symbol | Parameter | Test condition | Min. | Typ. | Max. | Unit |
|-------|-----|---------------------|------------------------------------|---|------|------|--------------------|------|
| A.049 | TW | V _{Tw_low} | Thermal warning output low voltage | R _{ext} ≥ 4.7 kΩ to V _O V _O =3.3 V; V _O =5 V | | | 0.2xV _O | V |

| Item | Pin | Symbol | Parameter | Test condition | Min. | Typ. | Max. | Unit |
|-------|-------|-------------------------|------------------------------------|---|------|------|-------|-------------|
| A.050 | TW | T_{warn} | Thermal warning temperature | | 140 | 150 | 160 | °C |
| A.051 | TW | $T_{\text{warn_hyst}}$ | Thermal warning hysteresis | | 3 | 11 | 15 | °C |
| A.052 | V_O | OV | V_O overvoltage | $V_S = 5\text{ V}; 13.5\text{ V}; V_O$ increasing $V_O=3.3\text{ V}; V_O=5\text{ V}$ | 6.5% | 10% | 13.5% | Above V_O |
| A.056 | V_O | O_{V_hyst} | V_O overvoltage hysteresis | $V_S = 5\text{ V}; 13.5\text{ V}; V_O$ decreasing $V_O=3.3\text{ V}; V_O=5\text{ V}$ | | 2% | | Below V_O |
| A.054 | TW | T_{w_per} | Thermal warning square wave period | $V_S = 5\text{ V}; 13.5\text{ V}$ $V_O=3.3\text{ V}; V_O=5\text{ V}$ | 160 | 250 | 300 | μs |

Note: all parameters are guaranteed in the junction temperature range -40°C to 150°C (unless otherwise specified); L99VR01J device is still operative and functional at higher temperatures (up to 175°C). Parameters limit at higher junction temperature than 150°C may change respect to what is specified as per the standard temperature range. device functionality at high junction temperature is guaranteed by characterization. All parameters are guaranteed by design for V_O not reported in test condition.

Note: minimum input voltage values are achievable adopting an input ceramic capacitor: C5750X7R2A475M230KA – ceramic capacitor multistrate SMD, 4.7 μF, 100 V, ±20%, X7R, C series TDK.

2.4 Electrical characteristics curves

Figure 4. Output voltage vs Tj

Figure 5. Output voltage vs VS

Figure 6. Drop voltage vs output current

Figure 7. Current consumption vs output current

Figure 8. Current consumption vs input voltage (Io < 1 mA)

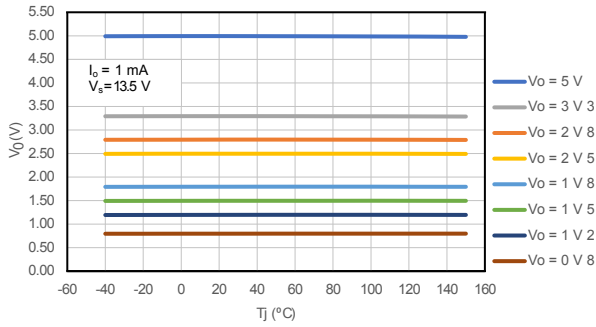
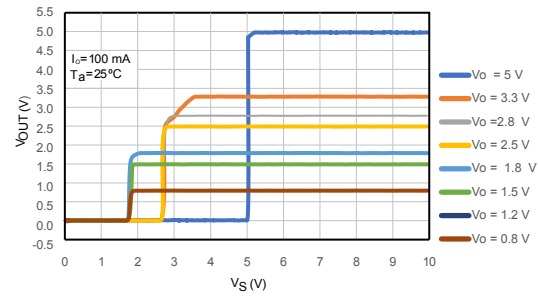
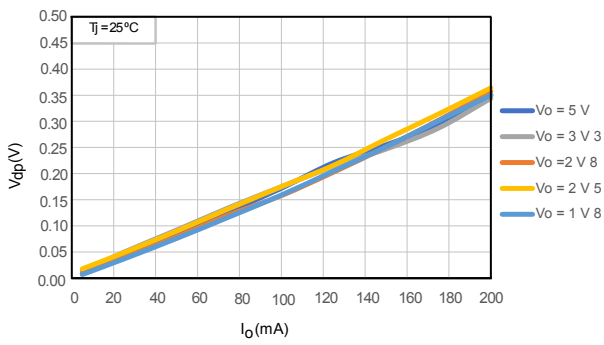
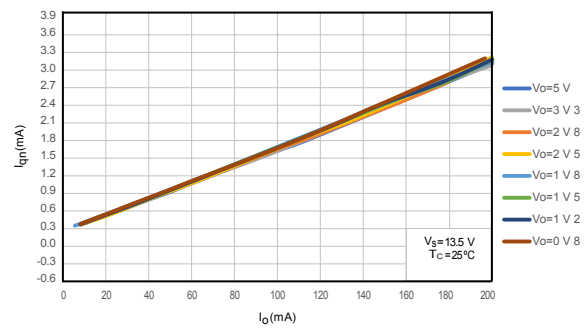
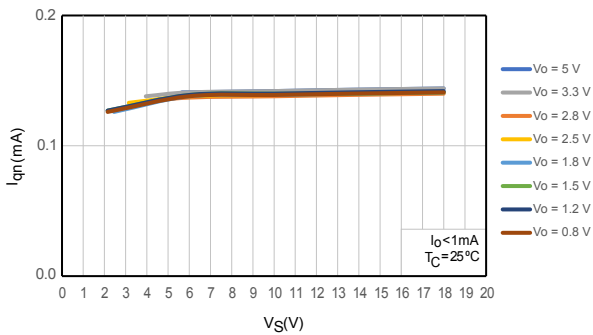
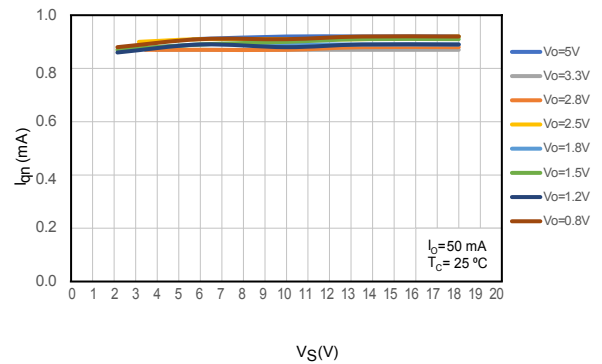
Figure 9. Current consumption vs input voltage (Io = 50 mA)

Figure 10. Current consumption vs input voltage ($I_O = 100\text{ mA}$)

Figure 11. Short-circuit current vs T_j (I_{short} pin floating)

Figure 12. Short-circuit current vs T_j (I_{short} pin tied to GND)

Figure 13. Short-circuit current vs input voltage

Figure 14. Output voltage vs enable voltage ($V_O = 0.8\text{ V}$)

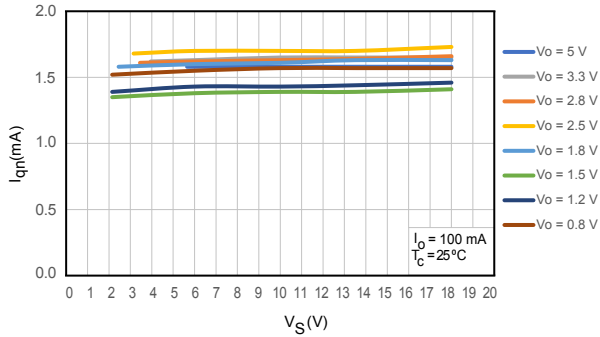
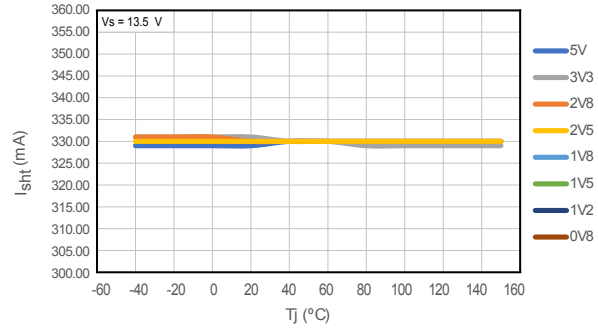
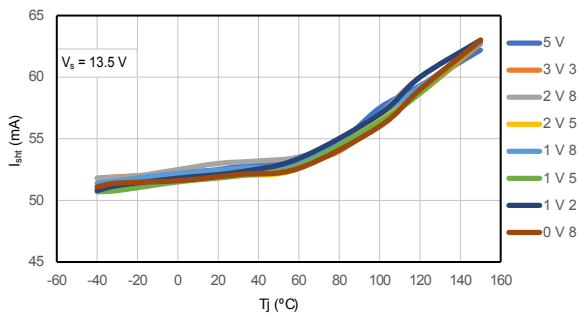
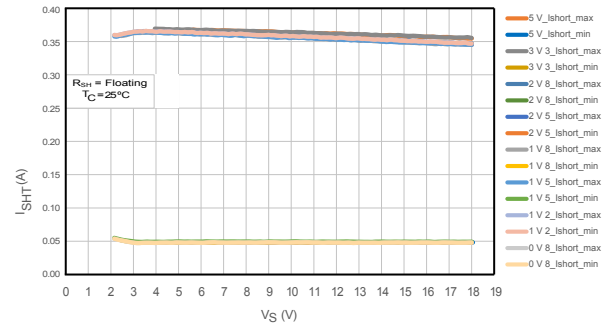
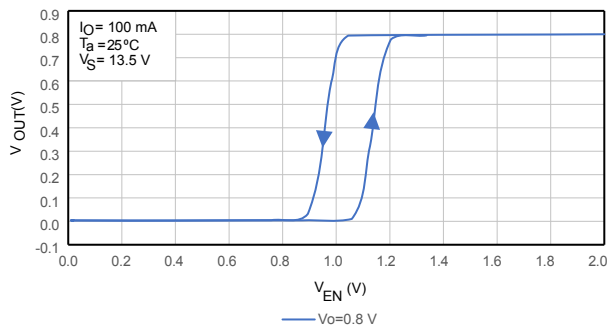
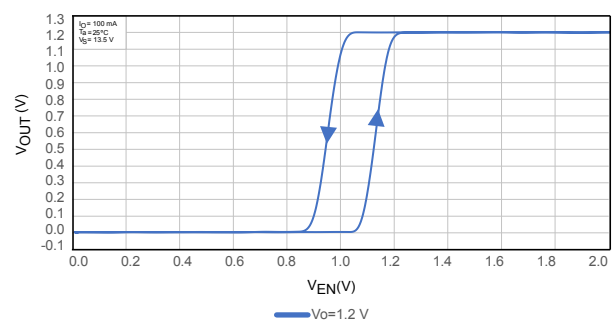
Figure 15. Output voltage vs enable voltage ($V_O = 1.2\text{ V}$)

Figure 16. Output voltage vs enable voltage ($V_O = 1.5\text{ V}$)

Figure 17. Output voltage vs enable voltage ($V_O = 1.8\text{ V}$)

Figure 18. Output voltage vs enable voltage ($V_O = 2.5\text{ V}$)

Figure 19. Output voltage vs enable voltage ($V_O = 2.8\text{ V}$)

Figure 20. Output voltage vs enable voltage ($V_O = 3.3\text{ V}$)

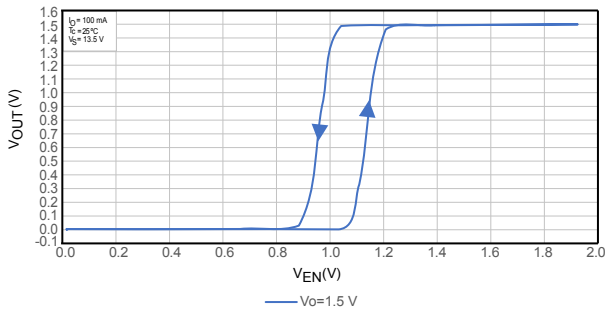
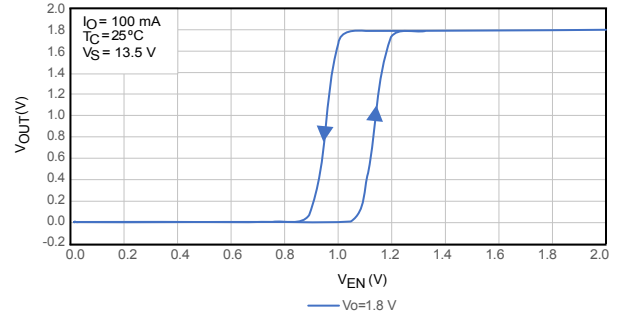
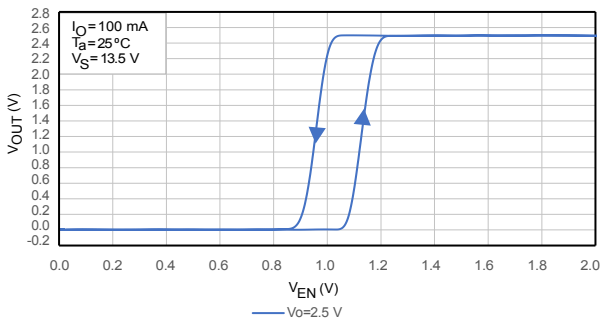
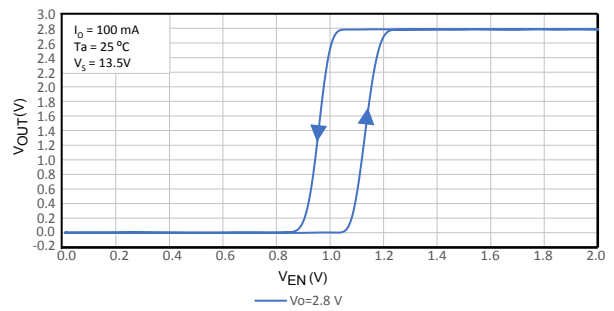
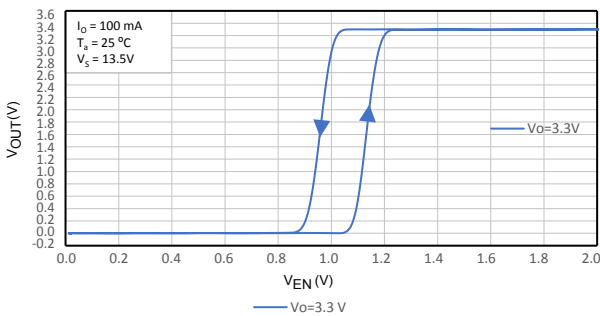
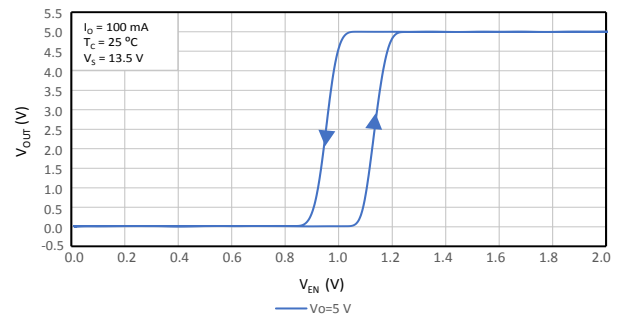
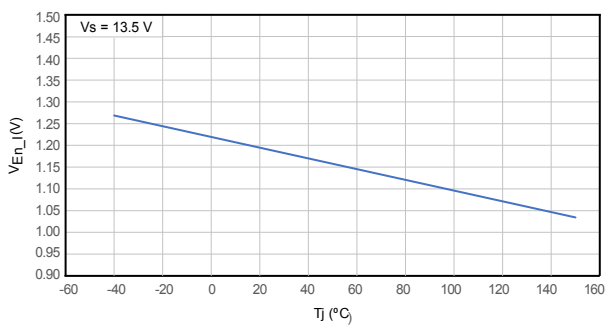
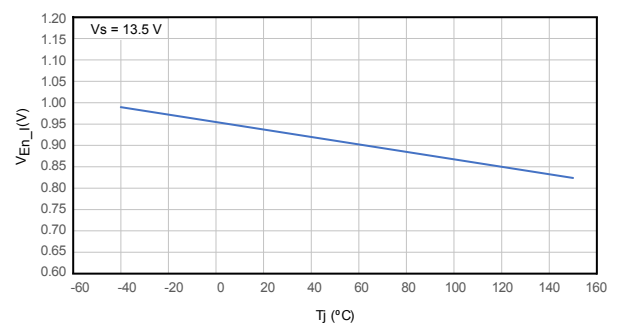
Figure 21. Output voltage vs enable voltage ($V_O = 5\text{ V}$)

Figure 22. V_{EN_high} vs T_j

Figure 23. V_{EN_low} vs T_j

Figure 24. V_{wth} vs T_j

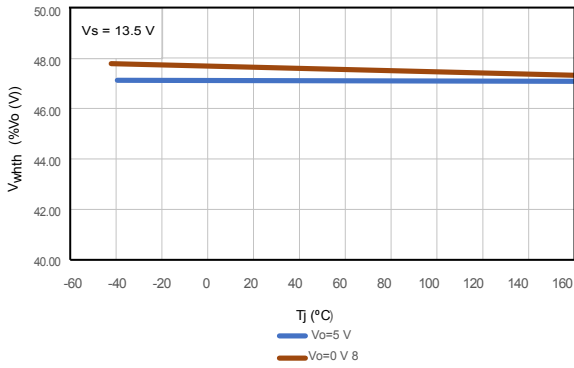

Figure 25. V_{wth} vs T_j

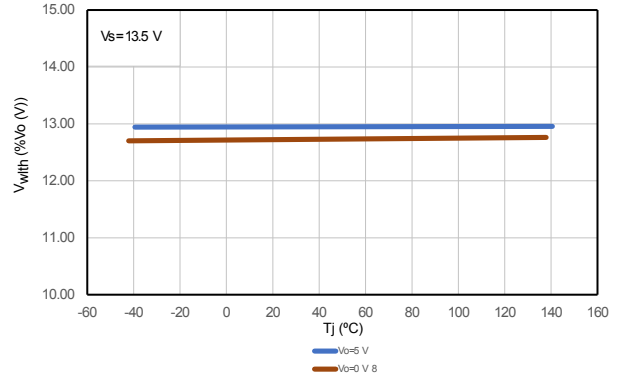

Figure 26. I_{cwC} vs T_j

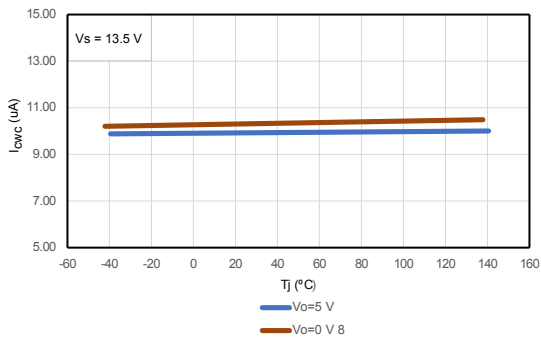

Figure 27. I_{cwD} vs T_j

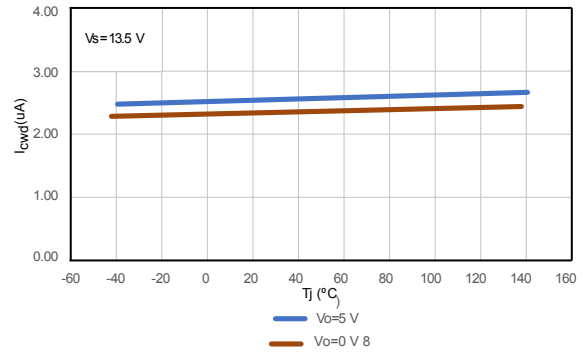
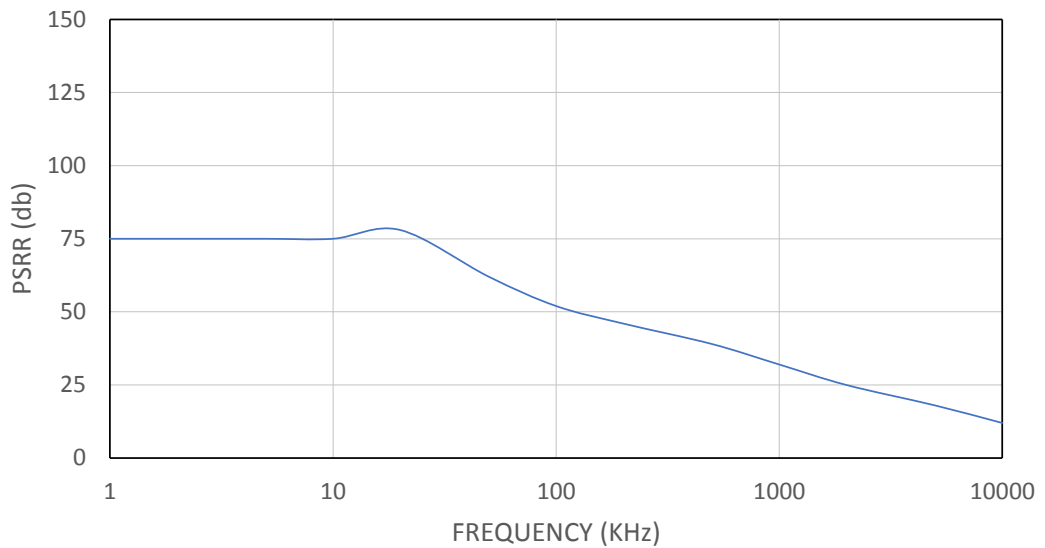
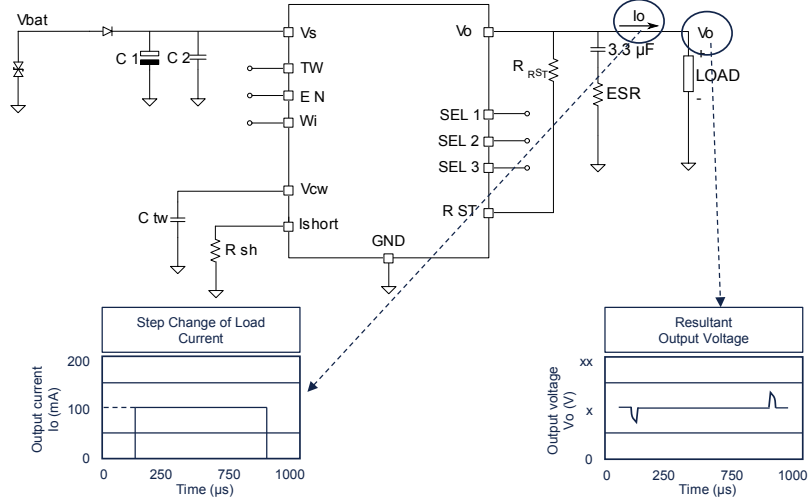
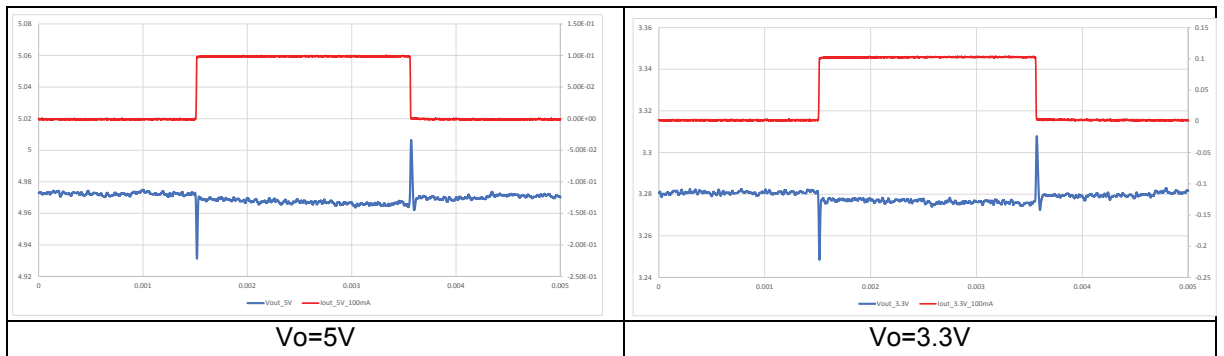

Figure 28. PSRR



3 Test circuit and waveforms plot

3.1 Load regulation

Figure 29. Load regulation test circuit

Figure 30. Maximum load variation response

4 Application information

Figure 31. Application schematic

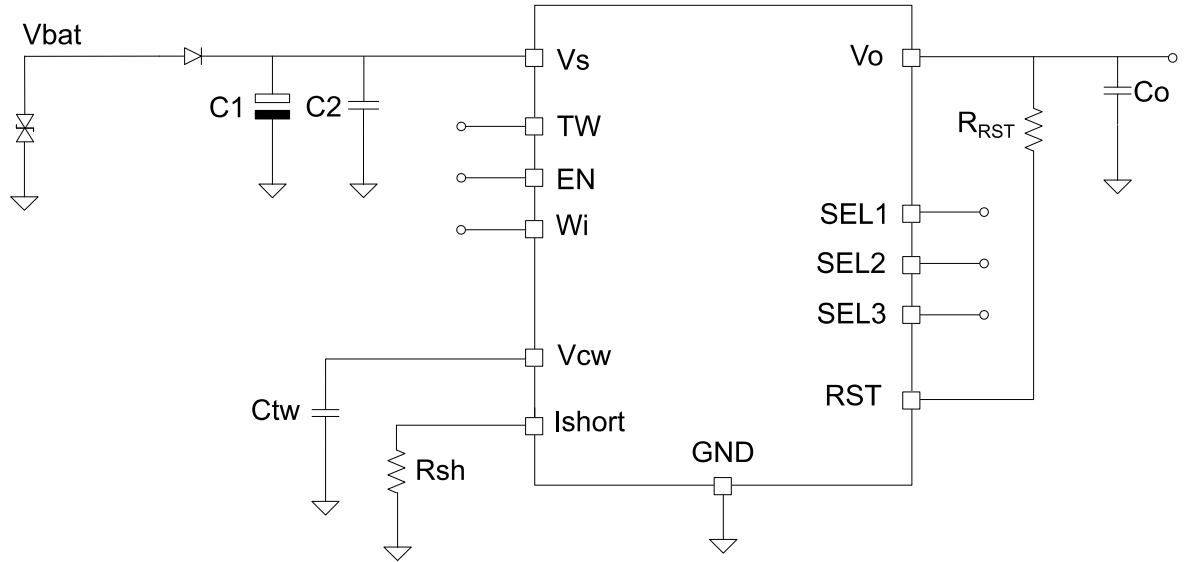
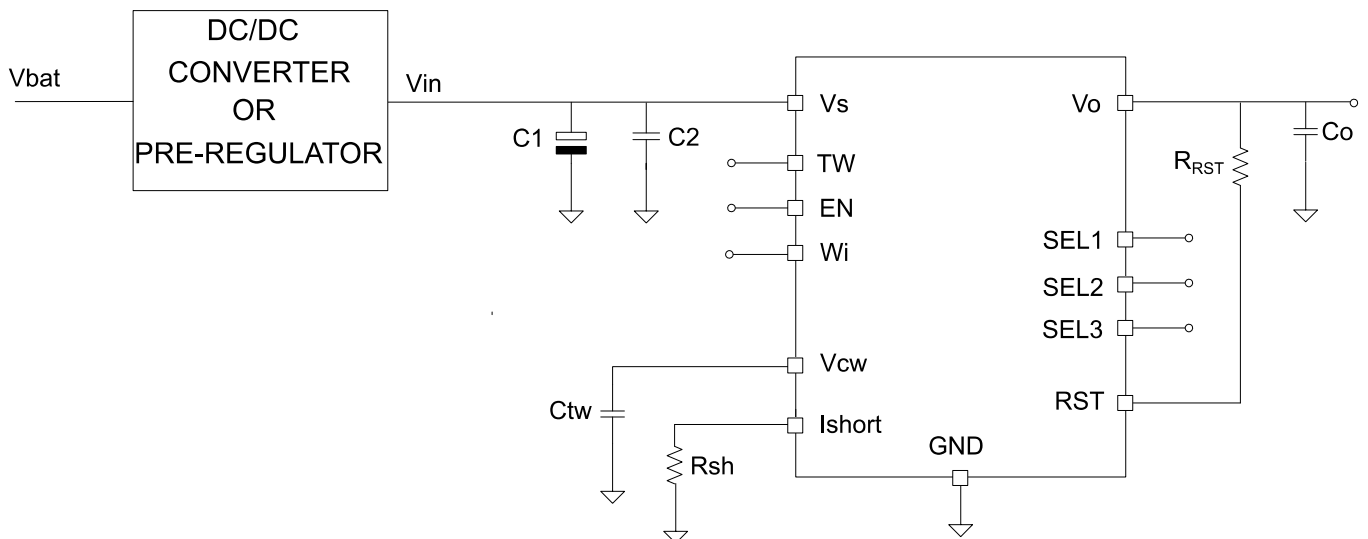

Figure 32. Application schematic – Post regulation



Input ceramic capacitor $C_2 \geq 4.7 \mu\text{F}$ is necessary for the regulator to operate properly. The other input capacitor C_1 can be used as backup supply for the application. The C_0 capacitor, connected to the output pin, is for bypassing to GND the high-frequency noise and it guarantees stability even during sudden line and load variations.

Suggested value is $C_0 = 3.3 \mu\text{F}$.

The ESR of the SMD output ceramic capacitor has a negligible effect on the stability of the L99VR01 family for capacitors with low ESR. A ceramic SMD capacitor is recommended on V_o pin.

4.1 Voltage regulator

The voltage regulator uses a p-channel MOS transistor as a regulating element. With this structure, a very low dropout voltage at current up to $I_o = 200\text{ mA}$ is obtained. The high-precision of the output voltage ($\pm 2\%$) is obtained with a pre-trimmed reference voltage. The voltage regulator automatically adapts its own quiescent current to the output current level. In light load conditions the quiescent current goes down to $I_{qn_LL} = 75\ \mu\text{A}$ (low consumption mode). L99VR01 operates with reduced input voltage (post regulation) minimizing the internal power dissipation and maximizing the output current.

4.2 Output current limitation

Output current limitation is present to protect the regulator and the application from overload condition, such as short to ground.

Figure 33. Behavior of output current versus regulated voltage V_o

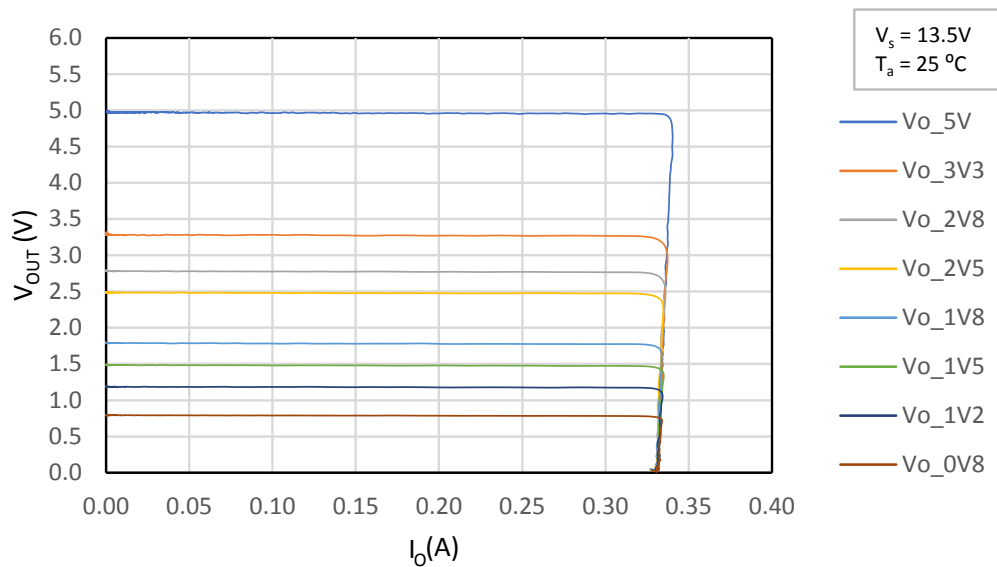

The I_{short} current can be set in the range from 65 mA to 360 mA through an external resistor R_{sh} connected between I_{short} pin and ground (L99VR01J version only).

Figure 34. Ishort versus Rsh

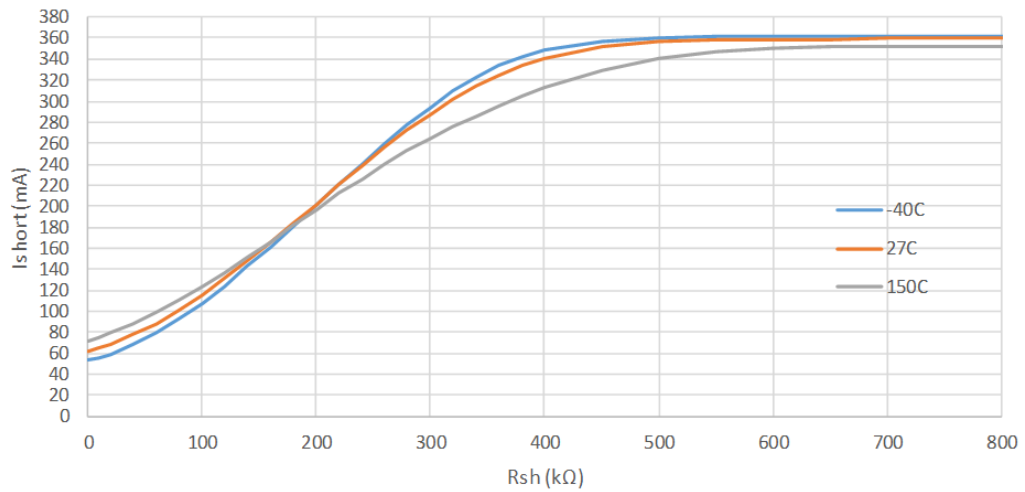

Open pin (no resistance on the Ishort pin), is seen as a max resistance corresponding to the maximum Ishort current.

4.3 Output voltage selection

The L99VR01 can provide one out of 8 different output voltages. The combination of three digital input selectors (SELx) determines the output voltage according to the following truth table.

Table 12. Truth table

| V_O | SEL1 | SEL2 | SEL3 |
|---------------|------|------|------|
| 5 | 1 | 1 | 1 |
| 3.3 | 1 | 1 | 0 |
| 2.8 | 1 | 0 | 1 |
| 2.5 | 1 | 0 | 0 |
| 1.8 | 0 | 1 | 1 |
| 1.5 | 0 | 1 | 0 |
| 1.2 | 0 | 0 | 1 |
| 0.8 (Default) | 0 | 0 | 0 |

The SELx pins configuration is acquired at the device start-up (EN transition from low to high) and once configuration is acknowledged, it cannot be changed until next EN transition.

When all the pins are left not connected, the default configuration will be selected.

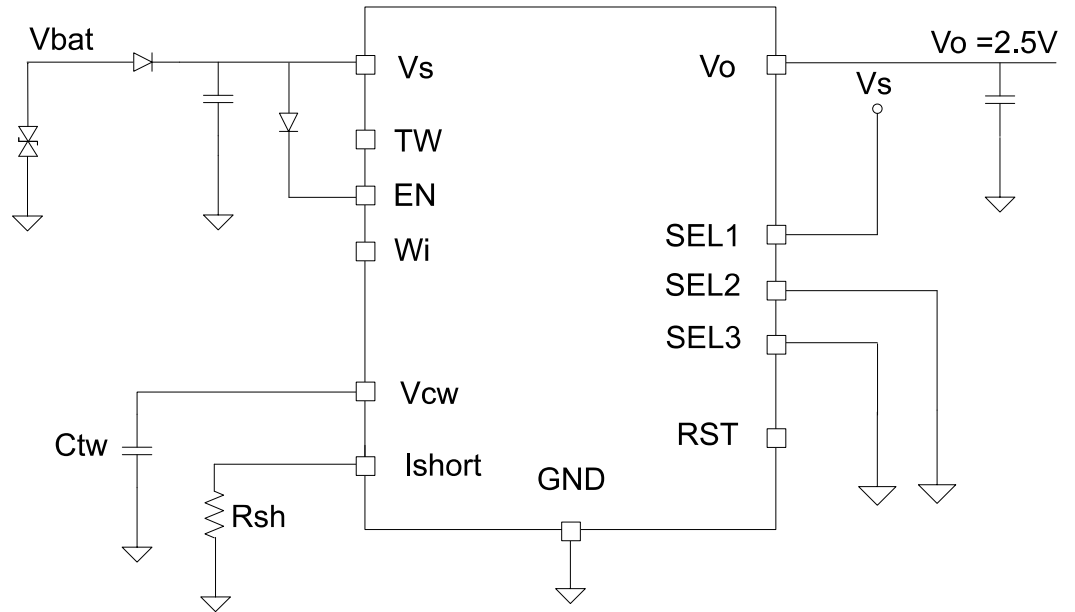
Figure 35. Example of output voltage selection

SELx pins are internally connected to GND via pull down current source.

4.4 Enable

The L99VR01 is enabled/disabled by the enable input; a high voltage signal switches the regulator ON. When the enable pin is set low, the output is switched-off, the current consumption of the device becomes as low as 1 μ A and the Fast Output Discharge circuit is activated.

It may happen that the enable pin must be driven by components supplied at a voltage different from the regulator supply voltage. In this case the EN input pin must be set high only once $V_S > 1.5$ V. A solution to drive the enable pin is depicted in the following figure.

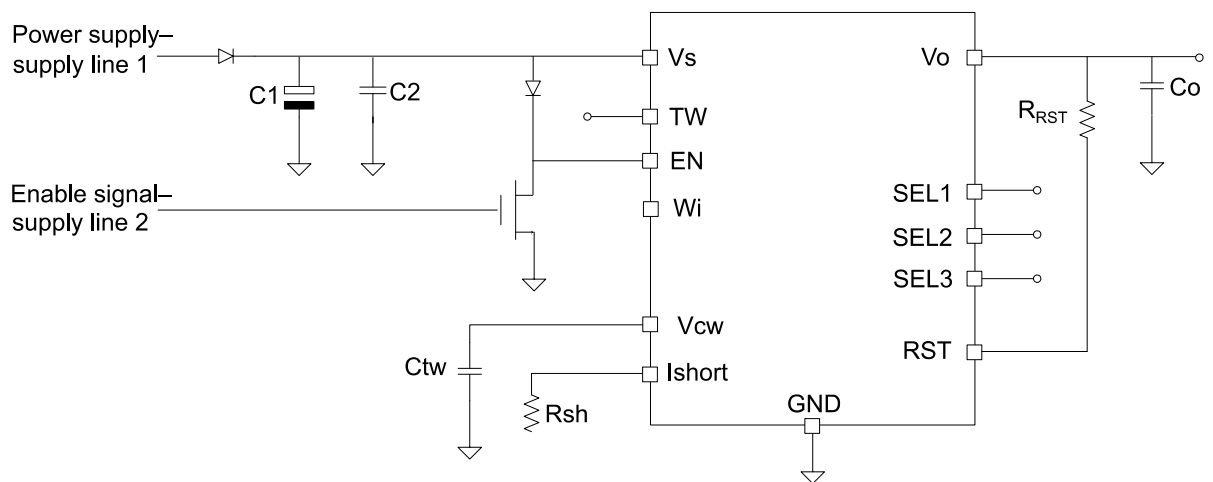
Figure 36. Typical example of enable control

In any case, since the enable input voltage is linked to the maximum DC supply voltage (V_S) applied to the L99VR01 (-0.3 V to $V_S + 0.3$ V), special care must be adopted in driving EN pin to avoid exceeding absolute maximum rating.

Note: A diode ($0.25\text{ V} < V_F < 0.75\text{ V}$) connected in series with EN pin is requested only if the regulator is directly supplied by car battery.

4.5 Reset

The reset circuit supervises the output voltage V_O . If the output voltage falls below V_{O_th} then RST is pulled low with a reaction time T_{rr} . When the output voltage rises above $V_{O_th} + V_{O_th_hyst}$ then RST is pulled high with a delay time T_{rd} . The delay is generated by an internal circuit. The reset circuit is active when En is high. Being RST an open-drain output an external resistance (R_{rst}) is needed between the RST pin and the Vo pin. The external resistance value can be in a range between 4.7 K Ω and 20 K Ω . Leave the RST pin floating if not used. Be aware that the current flowing through the RST pin drawn from Vo when the RST pin is pulled low may affect the watchdog activation/deactivation based on the regulator output current consumption monitoring.

Figure 37. Reset timing diagram

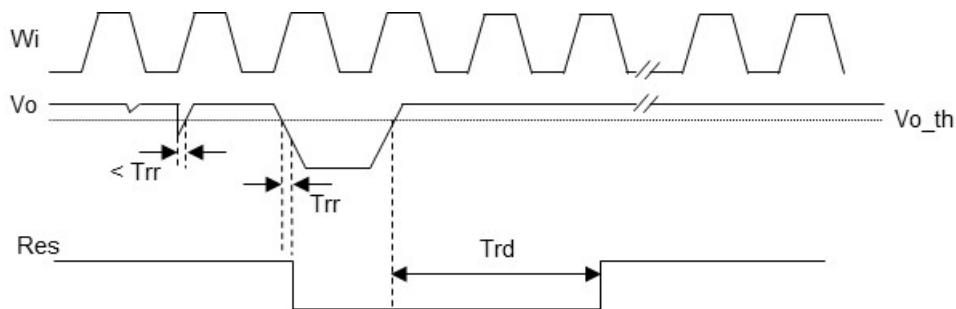

4.6 Autonomous watchdog

A supplied microcontroller is monitored by the watchdog input W_i (L99VR01J version only). If pulses are missing, the RST output pin is set low. The watchdog timeout can be set within a wide range with the external capacitor, C_{tw} . The watchdog circuit discharges the capacitor C_{tw} , with the constant current I_{CWd} . If the lower threshold V_{wlth} is reached, a watchdog reset is generated. To prevent this from happening the microcontroller must generate a positive edge during the discharge of the capacitor before the voltage reaches the threshold V_{wlth} . To calculate the sawtooth period " T_{wop} ", taking care that the microcontroller triggers the positive edge during the discharge phase of C_{tw} (T_d), the following equations can be used:

$$(V_{whth} - V_{wlth}) \times C_{tw} = I_{CWd} \times T_d$$

$$(V_{whth} - V_{wlth}) \times C_{tw} = I_{CWc} \times T_{wol}$$

$$T_{wop} = T_d + T_{wol}$$

Every W_i positive edge switches the current source from discharging to charging. The same happens when the lower threshold is reached. When the voltage reaches the upper threshold, V_{whth} , the current switches from charging to discharging. The result is a saw-tooth voltage at the watchdog timer capacitor C_{tw} . If a microcontroller operates in low power mode it will not be able to generate any pulse to refresh the voltage regulator watchdog, triggering so the microcontroller reset. In such a case, to avoid generating the microcontroller reset, the watchdog functionality will be automatically deactivated any time the microcontroller current consumption falls under the I_{w_off} threshold. On the other hand, when the current consumption rises above the I_{w_on} threshold the watchdog functionality will be once again activated. Once the regulator is enabled for the first time, if $I_o < I_{w_off}$ the watchdog will not be activated, while if $I_o > I_{w_off}$ the watchdog will be activated.

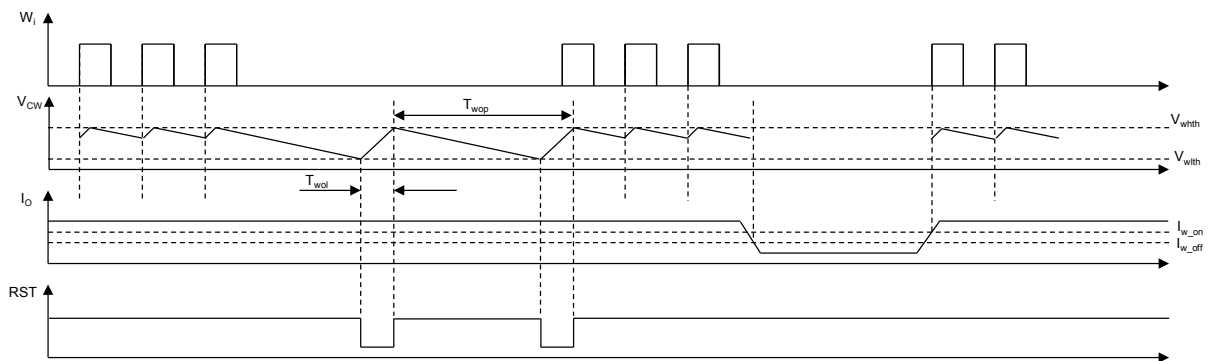
Figure 38. Watchdog timing diagram

Since the RST output pin is shared between the watchdog circuit and the output voltage monitoring circuit, for applications where the watchdog is not needed, to prevent the watchdog from generating RST pulses without anyhow losing the reset functionality of the Vo monitoring, the V_{cw} pin has to be connected to Vo. V_{cw} pin must be always tied to ground by an external capacitor (C_{tw}) when the watchdog is used.

Note: when the watchdog timer is used and the regulator recovers from a thermal shut-down event or recovers from an output under-voltage event (including the recovery from output under-voltage event at the regulator output turning on), the reset pin might be pulled back high with a delay longer than Trd , in the range between Trd and $Trd + Twol$ due to the watchdog that might affect the RST pin release. The watchdog will not affect the RST pin release in the case where recovering from a thermal shut-down event or recovering from an output under-voltage event (including the recovery from output under-voltage event at the regulator output turning on) the I_o drops below I_{w_off} before Trd . The output current I_o consists in the load current, the current drawn from the RST pin and the TW pin through the pull-down resistors connected to Vo when the RST and the TW pins are asserted low and the current needed to charge/discharge the output capacitor C_o .

Note: when the watchdog timer is used, in case of an output under-voltage event not making Vo drop to zero volt, since the watchdog will still be running during the output under-voltage condition, the first watchdog timeout after the reset pin is released coming out of the output under-voltage event might occur before expected ($0 \leq \text{Timeout} \leq Twop - Twol$).

Table 13. Watchdog timer

| Usage of watchdog timer | Connection of Vcw Pin |
|----------------------------|---|
| Watchdog timer is not used | Connect to the Vo pin |
| Watchdog timer is used | Connect to an external capacitor C_{tw} |

4.7 Thermal warning and thermal shutdown

To warn the microcontroller about a severe temperature increase, a thermal warning output has been implemented (L99VR01J version only). If the device detects a junction temperature above T_{warn} , the advanced thermal warning (TW) output pin is pulled low while the voltage regulator and its features remain all active. The TW pin will return to its high logic level (equal to the Vo output value) once the temperature falls below the threshold $T_{warn} - T_{warn_hyst}$.

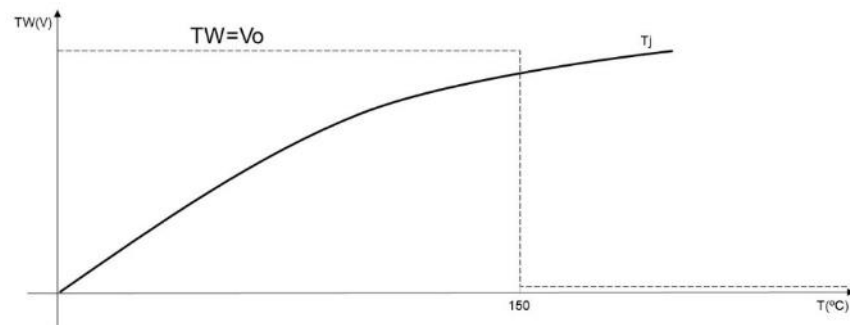
Figure 39. Thermal warning diagram

When junction temperature reaches the $T_{prot_j/s}$ thermal shutdown threshold the regulator output is quickly shut-off through the internal Fast Output Discharge circuit; to be reactivated, junction temperature has to decrease below $T_{prot_j/s} - T_{prot_hyst}$. Being TW an open-drain output an external resistance (R_{TW}) is needed between the TW pin and the Vo pin. The external resistance value can be in a range between 4.7 K Ω and 20 K Ω . Be aware that the current flowing through the TW pin drawn from Vo when the TW pin is pulled low may affect the watchdog activation/deactivation based on the regulator output current consumption monitoring. Leave floating if not used.

4.8 Overvoltage detection by advanced thermal warning read-out

The TW pin also provides diagnostics about output overvoltage (OV); to distinguish between a thermal warning event and an output overvoltage event, two different signals are generated at the same TW output pin. How reported in the previous paragraph a thermal warning event detection sets the TW pin LOW, instead an output overvoltage event generates a square wave at the TW pin (Figure 40. Square wave on TW pin generated during an overvoltage). Overvoltage detection has higher priority than thermal warning detection so that concurrence of thermal warning and over voltage events leads to a square wave like in the case of overvoltage detection (as shown in Figure 41. Warning signal caused by overvoltage and thermal warning on TW pin).

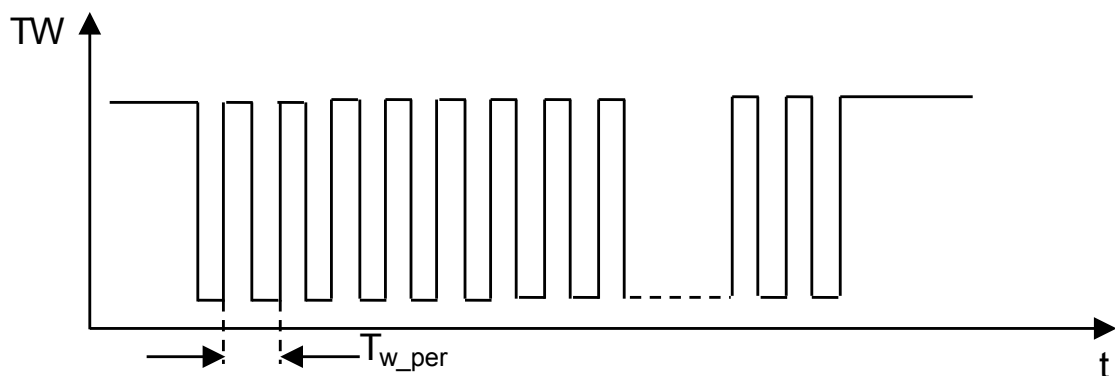
Figure 40. Square wave on TW pin generated during an overvoltage

A typical example of thermal warning and overvoltage failures management is depicted in Figure 41. Warning signal caused by overvoltage and thermal warning on TW pin.

Figure 41. Warning signal caused by overvoltage and thermal warning on TW pin

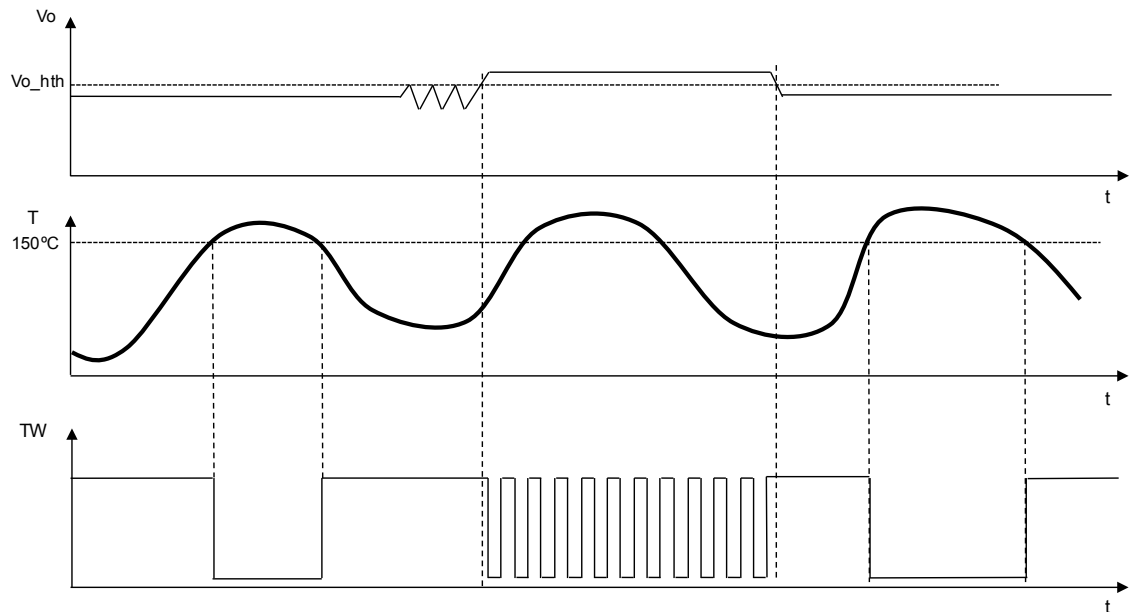

4.9 Fast output discharge

To assure a quick discharge of the external capacitor tied to the output pin down to around 1.3 V the L99VR01 uses an internal pulldown circuit. Activated each time the EN pin goes low, during thermal shut down and during undervoltage lockout, the output current will flow through the pulldown resistor of the fast output discharge circuit to ground. The fast output discharge feature is available for the output voltages $V_o = 2.5\text{ V}$ (SELx = [1;0;0]) $V_o = 2.8\text{ V}$ (SELx = [1;0;1]) $V_o = 3.3\text{ V}$ (SELx = [1;1;0]) and $V_o = 5\text{ V}$ (SELx = [1;1;1]).

4.10 Undervoltage lockout UVLO

The undervoltage lockout (UVLO) circuit allows a fast regulating element to turn off (activating the internal Fast Output Discharge circuit) if the input voltage drops below the threshold, V_{UVLO_fall} , avoiding undesired unknown output state during low input voltage. When the input voltage is above the V_{UVLO_rise} threshold, the regulating element is again turned on.

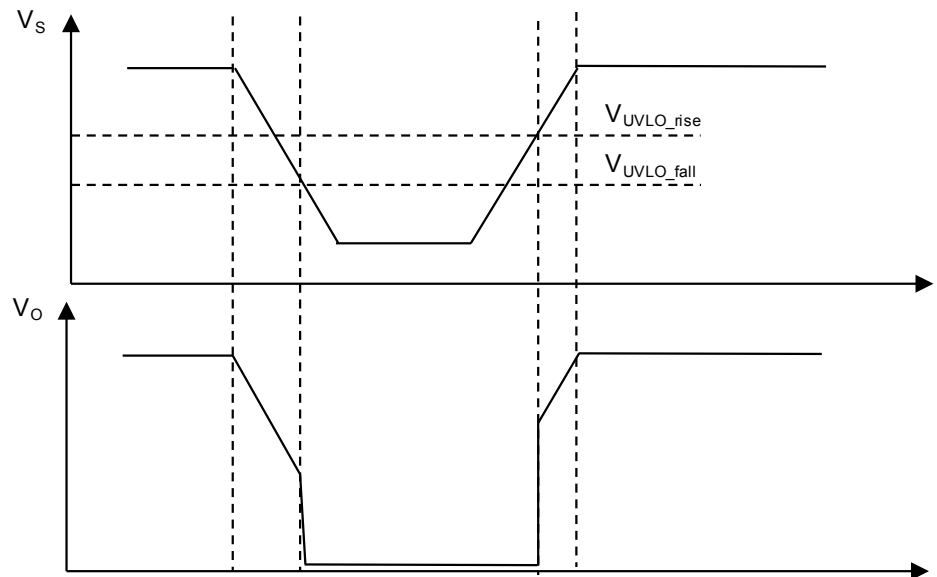
Figure 42. Undervoltage lockout on output voltage

4.11 Functional safety management

The device was designed to offer a set of features to support applications that need to fulfill functional safety requirements as defined by ASIL classification in ISO26262-2018. The IC was developed for different applications, hence can be considered a SEooC (Safety Element out of Context) as defined in the normative. Analysis of the IC's capability to reach the required safety level, should be made at system level under user responsibility.

The following device safety requirements have been considered for a typical application:

Table 14. Safety requirement

| ID | Description |
|--------|--|
| SR-001 | Operation of the voltage regulator(s) is allowed till over temperature limit. |
| SR-002 | Operation of voltage regulator(s) is enabled until programmed current limit is reached. |
| SR-003 | Output voltage of regulator(s) shall remain within programmed range when RST pin is not asserted. |
| SR-004 | Output voltage of regulator(s) shall remain within programmed range when square wave at TW pin is not generated. |

Based on above requirements list the following safety mechanism has been implemented:

Table 15. Implemented safety mechanism

| ID | Description | SR covered |
|-----|--|------------|
| SM1 | Thermal sensor acting by TW pin | SR-004 |
| SM2 | Overtemperature protection | SR-001 |
| SM3 | Limitation on maximum output current | SR-002 |
| SM4 | Output voltage V_o monitoring for undervoltage detection | SR-002 |

| ID | Description | SR covered |
|-----|---|------------|
| SM5 | Output voltage V_O monitoring for overvoltage detection | SR-002 |
| SM6 | RST reset assertion in case of V_O undervoltage detection | SR-003 |

In addition to the internal watchdog for checking the correct operation of the microcontroller, it can be considered a system-level safety mechanism.

More details about functional safety can be found in the device safety manual, provided on customer request.

5 Application

Figure 43. Typical application

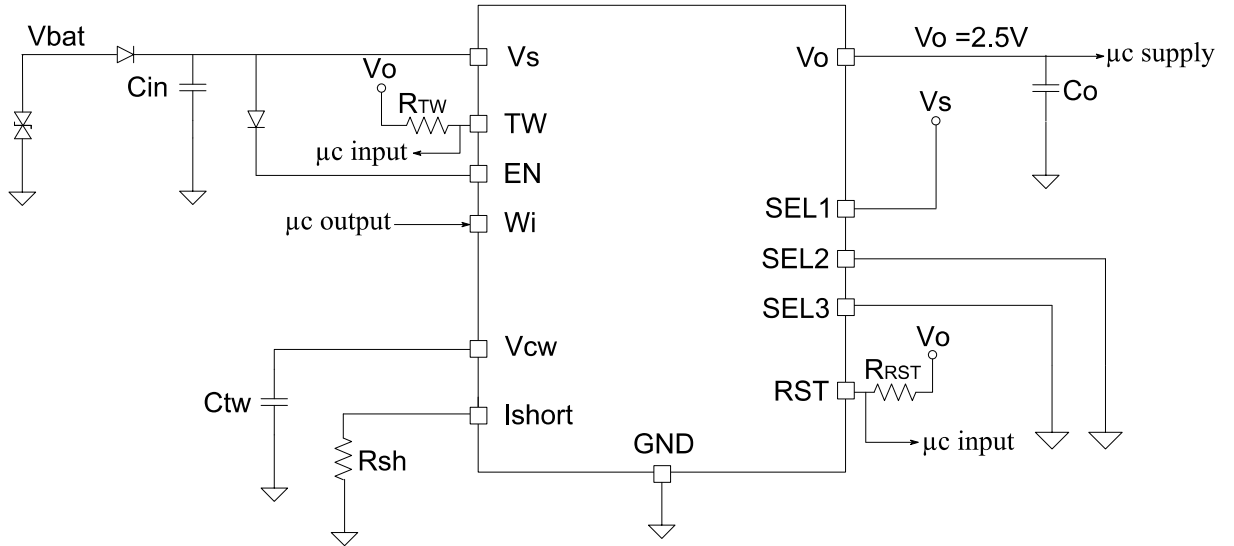

6 Package and PCB thermal data

6.1 PowerSSO-12 Thermal data

Figure 44. PowerSSO-12 PC board

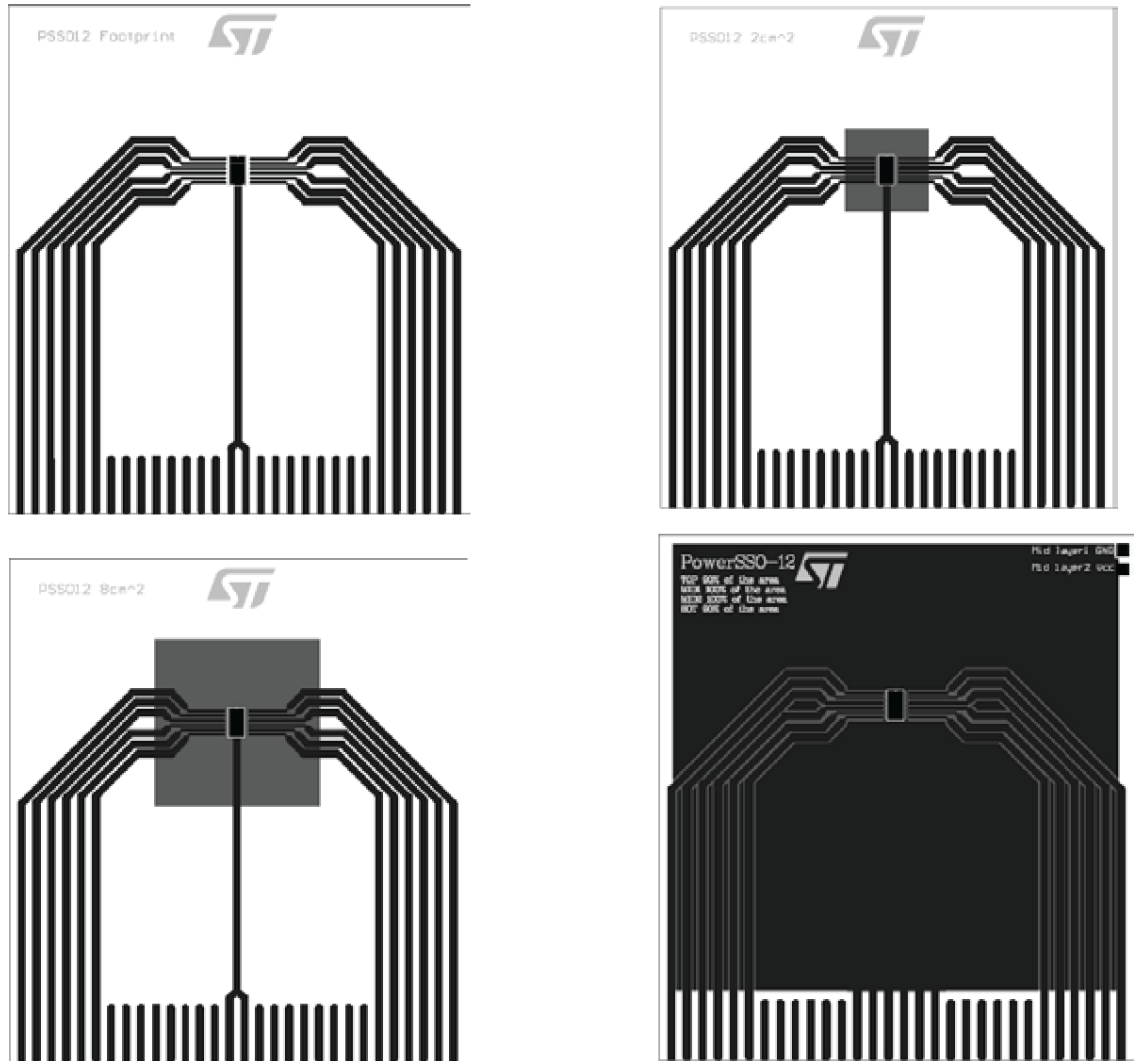

Note: layout condition of R_{th} and Z_{th} measurements (PCB: Double layer and Four layers, Thermal Vias, FR4 area= 77 mm x 86 mm, PCB thickness=1.6 mm, Cu thickness=0.070 mm (front and back side), Cu thickness 0.035 mm (inner layers). Thermal vias separation 1.2 mm, Thermal via diameter 0.3 mm +/- 0.08 mm, Cu thickness on vias 0.025 mm, Footprint dimension 2.2 mm x 2.9 mm.

Figure 45. Rthj-amb vs PCB copper area in open box free air condition (PowerSSO-12)

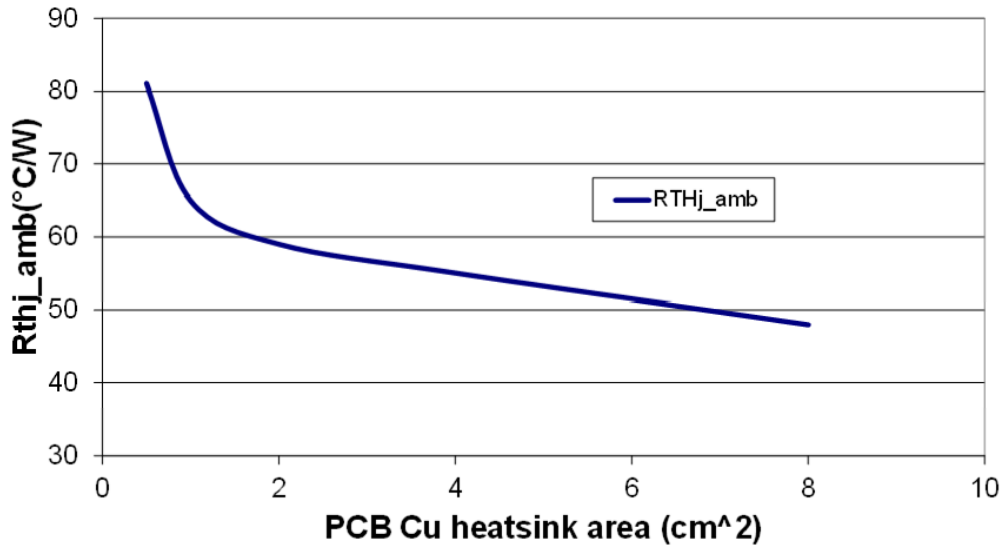
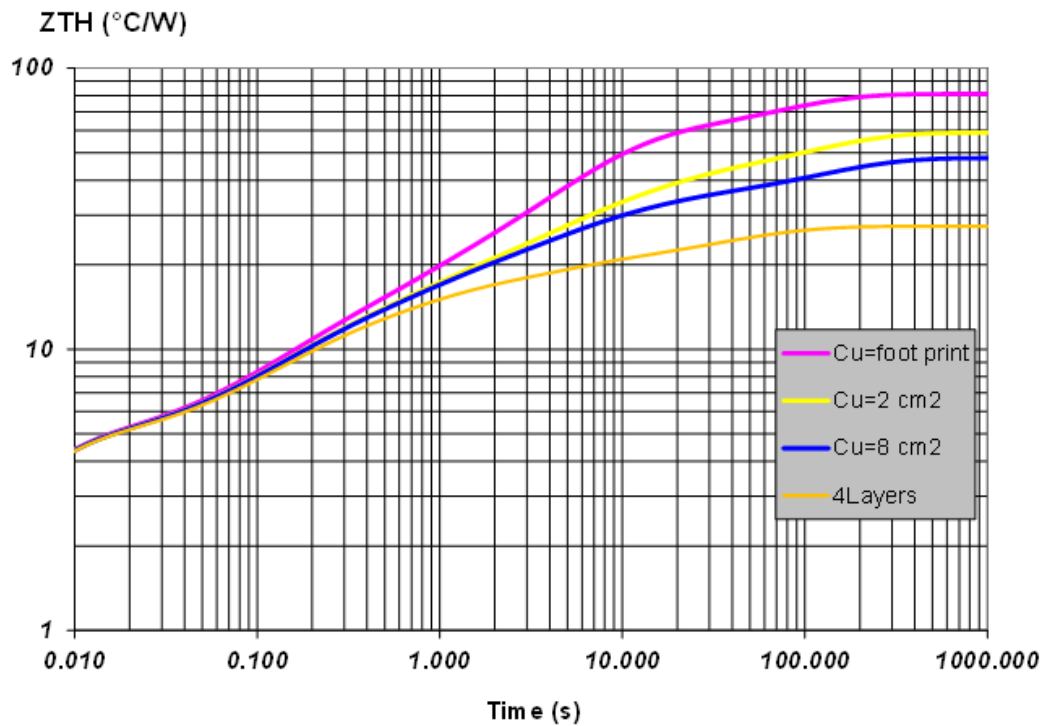

Figure 46. PowerSSO-12 thermal impedance junction ambient single pulse



Pulse calculation:

$$Z_{TH\delta} = R_{TH} \cdot \delta + Z_{THtp} (1 - \delta)$$

where $\delta = tp/T$

Figure 47. Thermal fitting model of a Vreg in PowerSSO-12

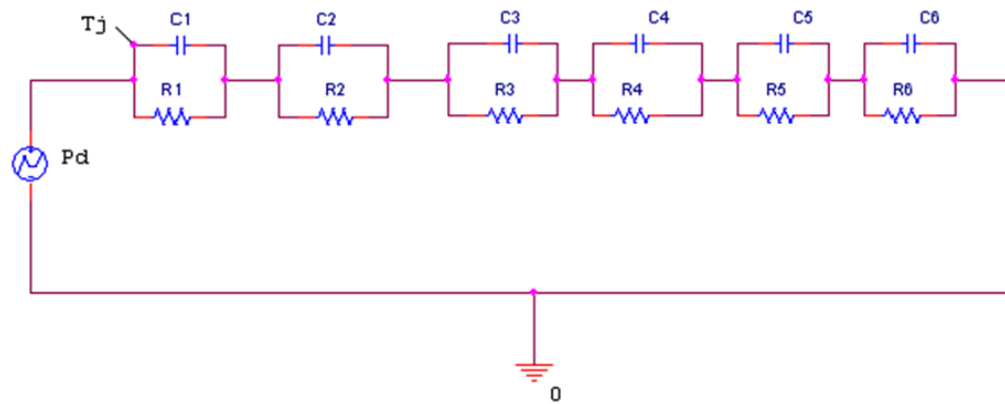
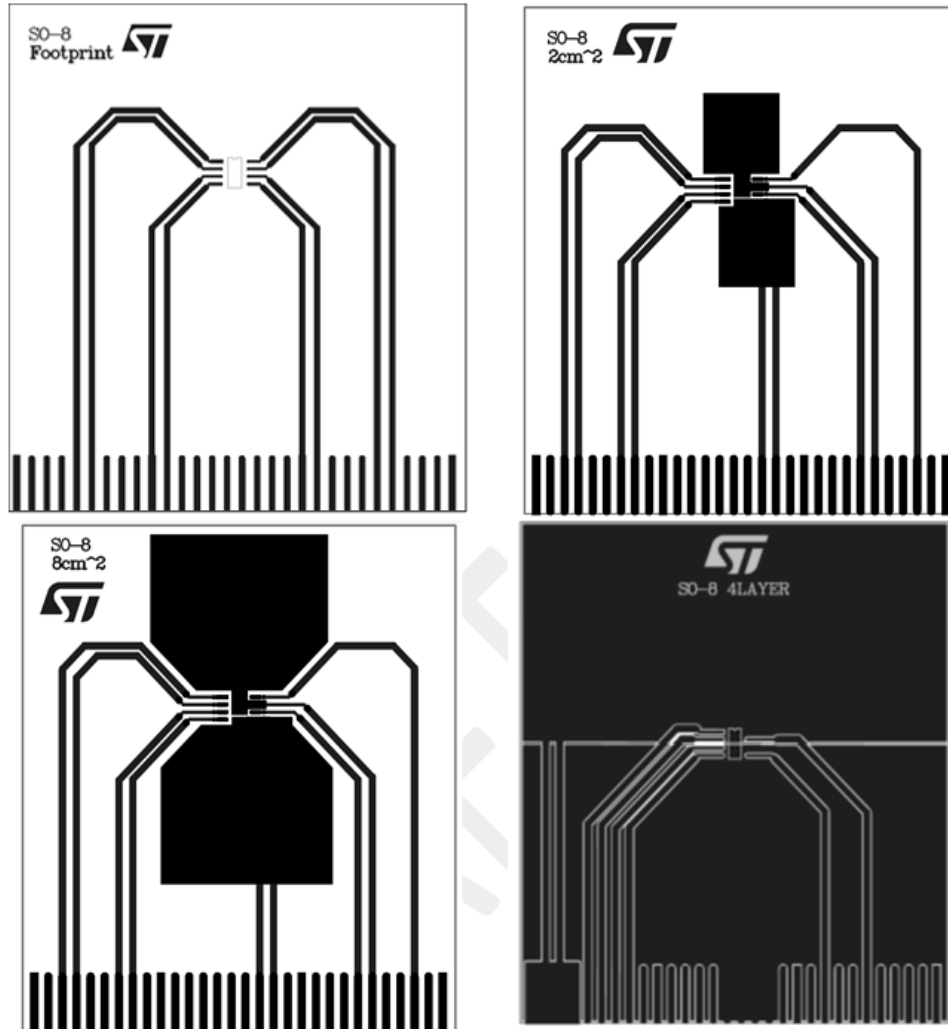

Table 16. PowerSSO-12 thermal parameter

| Area/island (cm ²) | Footprint | 2 | 8 | 4L |
|--------------------------------|-----------|-----|-----|-----|
| R1 (°C/W) | 4.4 | | | |
| R2 (°C/W) | 4.5 | | | |
| R3 (°C/W) | 6 | | | |
| R4 (°C/W) | 18 | 9 | 8 | 4.5 |
| R5 (°C/W) | 22 | 15 | 10 | 4 |
| R6 (°C/W) | 26 | 20 | 15 | 4 |
| C1 (W.s/°C) | 0.001 | | | |
| C2 (W.s/°C) | 0.03 | | | |
| C3 (W.s/°C) | 0.1 | | | |
| C4 (W.s/°C) | 0.4 | 0.4 | 0.4 | 0.8 |
| C5 (W.s/°C) | 0.27 | 0.8 | 1 | 7 |
| C6 (W.s/°C) | 3 | 6 | 9 | 15 |

6.2 SO-8 thermal data

Figure 48. SO-8 PC board



Note: *Layout condition of R_{th} and Z_{th} measurements (PCB: double layer and four layers; FR4 area = 77 mm x 86 mm; PCB thickness = 1.6 mm; Cu thickness = 0.070 mm (front and back side), Cu thickness 0.035mm (inner layers); Thermal via separation 1.2 mm, Thermal via diameter 0.3 mm +/- 0.08 mm; Cu thickness on vias of 0.025 mm, Footprint dimension 2.2 mm x 2.9 mm.*

Figure 49. Rthj-amb vs PCB copper area in open box free air condition

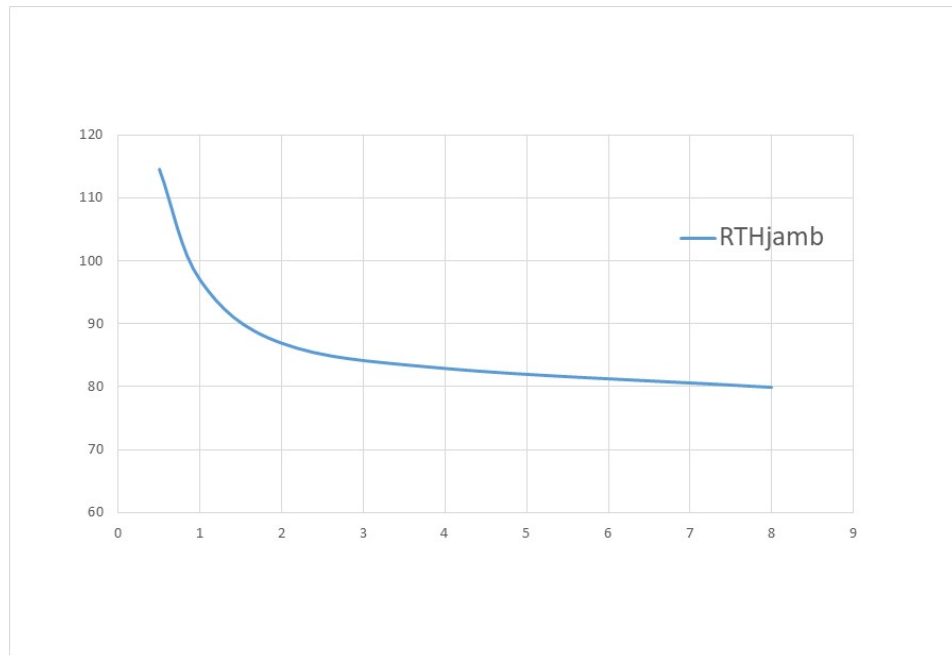
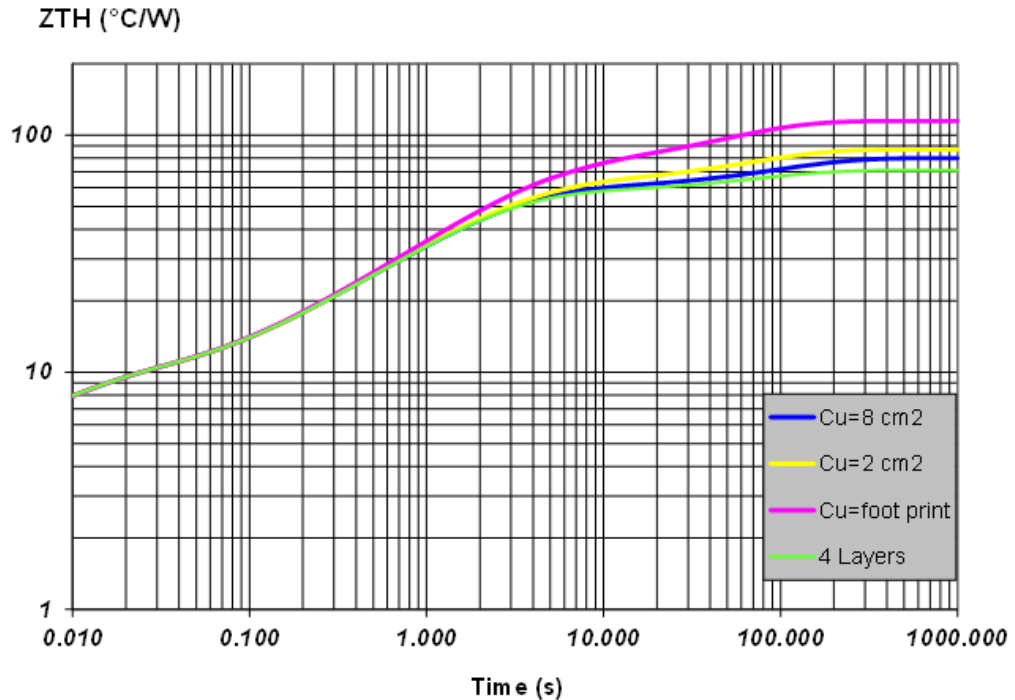

Figure 50. SO-8 thermal impedance junction ambient single pulse



Pulse calculation formula:

$$Z_{TH\delta} = R_{TH} \cdot \delta + Z_{THtp} (1 - \delta)$$

$$Z_{TH\delta} = R_{TH} \cdot \delta + Z_{THtp} (1 - \delta)$$

where $\delta = tp/T$

Figure 51. Thermal fitting model of a Vreg in SO-8

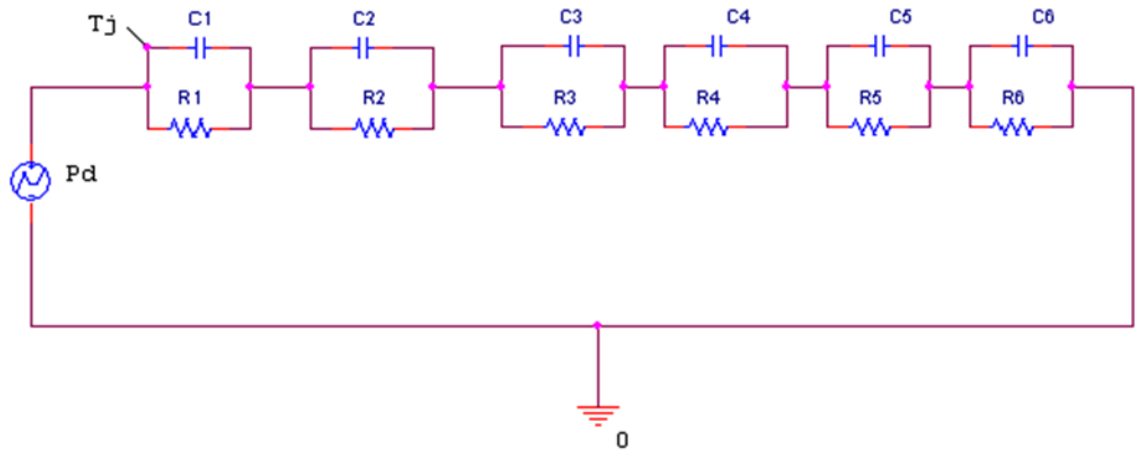

Table 17. SO-8 thermal parameter

| Area/island (cm ²) | Footprint | 2 | 8 | 4L |
|--------------------------------|-----------|----|----|-----|
| R1 (°C/W) | 4.4 | | | |
| R2 (°C/W) | 4.5 | | | |
| R3 (°C/W) | 6 | | | |
| R4 (°C/W) | 28 | 23 | 23 | 23 |
| R5 (°C/W) | 30 | 24 | 21 | 19 |
| R6 (°C/W) | 41.6 | 25 | 21 | 14 |
| C1 (W.s/°C) | 0.0001 | | | |
| C2 (W.s/°C) | 0.002 | | | |
| C3 (W.s/°C) | 0.03 | | | |
| C4 (W.s/°C) | 0.05 | | | |
| C5 (W.s/°C) | 0.15 | | | |
| C6 (W.s/°C) | 1.4 | 3 | 5 | 5.5 |

7 Package information

In order to meet environmental requirements, ST offers these devices in different grades of **ECOPACK** packages, depending on their level of environmental compliance. ECOPACK specifications, grade definitions and product status are available at: www.st.com. ECOPACK is an ST trademark.

7.1 PowerSSO-12 package information

Figure 52. PowerSSO-12 package dimensions

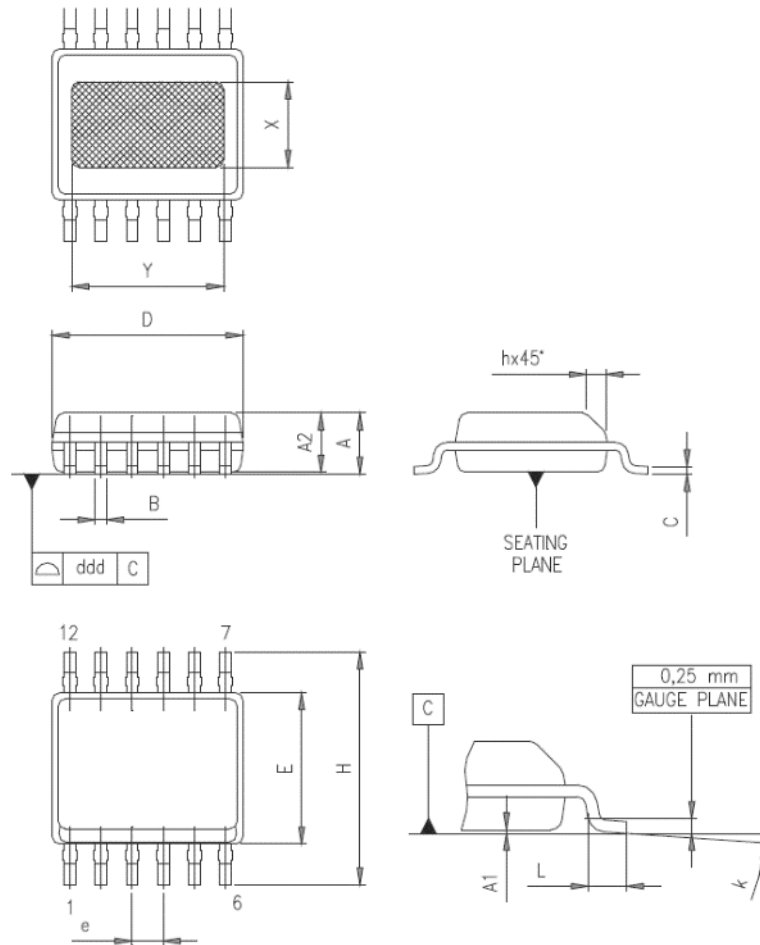

Table 18. PowerSSO-12 package mechanical data

| Symbol | Millimeters | | |
|--------|-------------|------|-------|
| | Min | Typ. | Max |
| A | 1.250 | | 1.620 |
| A1 | 0.000 | | 0.100 |
| A2 | 1.100 | | 1.650 |
| b | 0.230 | | 0.410 |
| c | 0.190 | | 0.250 |
| D | 4.800 | | 5.000 |

| Symbol | Millimeters | | |
|--------|-------------|-------|-------|
| | | | |
| E | 3.800 | | 4.000 |
| e | | 0.800 | |
| H | 5.800 | | 6.200 |
| h | 0.250 | | 0.500 |
| L | 0.400 | | 1.270 |
| k | 0° | | 8° |
| X | 2.200 | | 2.800 |
| Y | 2.900 | | 3.500 |
| ddd | | | 0.100 |

7.2 SO-8 package information

Figure 53. SO-8 package dimension

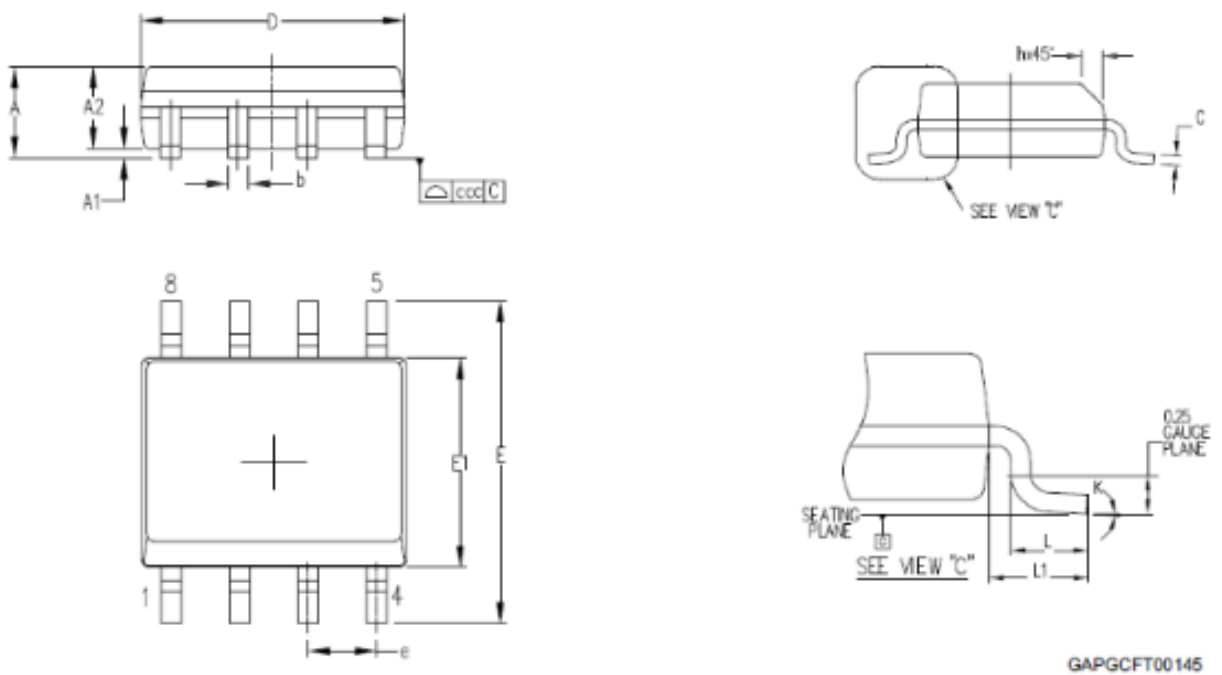

GAPGCF00145

Table 19. SO-8 package mechanical data

| Symbol | Millimeters | | |
|------------------|-------------|------|------|
| | Min | Typ. | Max |
| A | | | 1.75 |
| A1 | 0.10 | | 0.25 |
| A2 | 1.25 | | |
| b | 0.28 | | 0.48 |
| c | 0.17 | | 0.23 |
| D ⁽¹⁾ | 4.80 | 4.90 | 5.00 |
| E | 5.80 | 6.00 | 6.20 |

| Symbol | Millimeters | | |
|-------------------|-------------|------|------|
| E1 ⁽²⁾ | 3.80 | 3.90 | 4.00 |
| e | | 1.27 | |
| h | 0.25 | | 0.50 |
| L | 0.40 | | 1.27 |
| L1 | | 1.04 | |
| k | 0° | | 8° |
| ccc | | | 0.10 |

1. Dimensions D does not include mold flash, protrusions or gate burrs. Mold flash, protrusions or gate burrs shall not exceed 0.15 mm in total (both side).
2. Dimension "E1" does not include interlead flash or protrusions. Interlead flash or protrusions shall not exceed 0.25 mm per side.

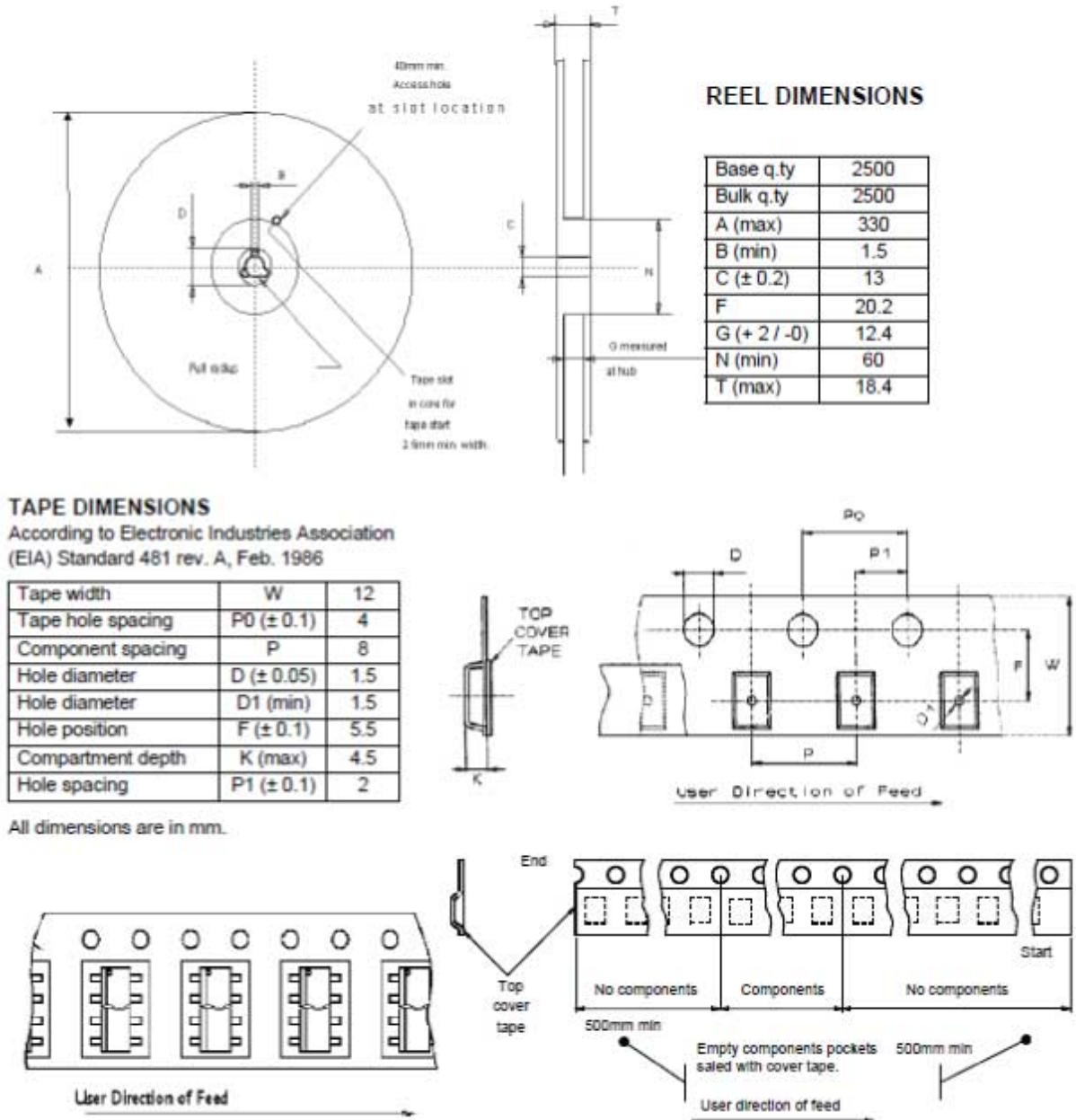
7.3 PowerSSO-12 packaging information
Figure 54. PowerSSO-12 tape and reel shipment (suffix "TR")

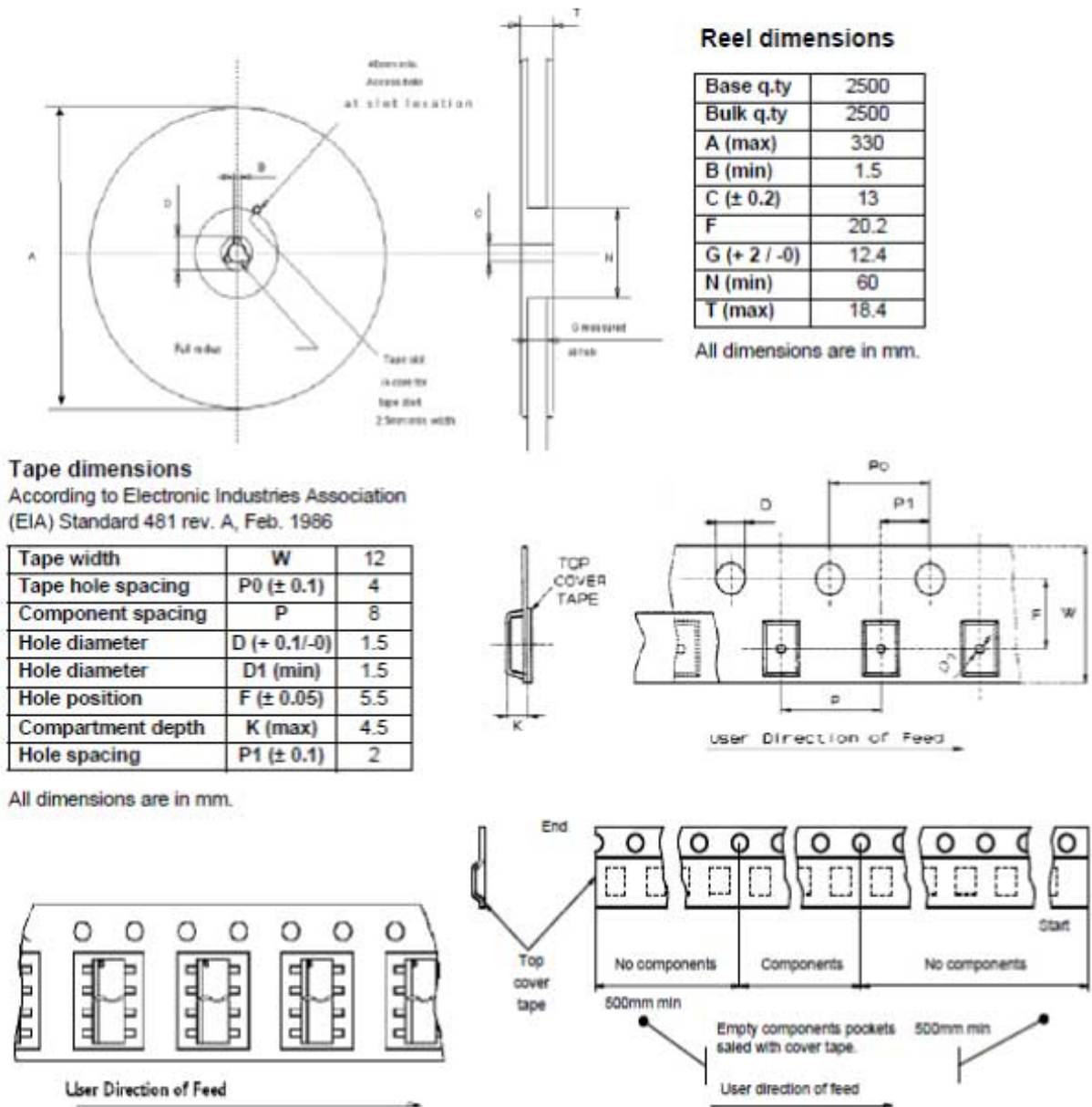
7.4 SO-8 packaging information
Figure 55. SO-8 tape and reel shipment (suffix "TR")

8 Order codes

| Order codes | | | | | |
|-------------|-------------|-------|---------------------|--------------------------|-------------|
| Order code | | | L99VR01 | | |
| Package | Tape & reel | | SO-8 | L99VR01STR | |
| | | | PowerSSO-12 | L99VR01JTR | |
| P/N | Enable | Reset | Autonomous watchdog | Advanced thermal warning | Ishort CTRL |
| L99VR01STR | X | X | - | - | - |
| L99VR01JTR | X | X | X | X | X |

Revision history

Table 20. Document revision history

| Date | Version | Changes |
|-------------|---------|--|
| 02-Mar-2021 | 1 | Initial release |
| 13-Apr-2021 | 2 | Updated Table 11. Thermal warning and protection (only for L99VR01J) ; Section 2.4 Electrical characteristics curves. |

Contents

| | | |
|----------|--|-----------|
| 1 | Block diagram and pins description | 3 |
| 2 | Electrical specifications | 6 |
| 2.1 | Absolute maximum ratings | 6 |
| 2.2 | Thermal data | 7 |
| 2.2.1 | Thermal resistance | 7 |
| 2.2.2 | Thermal protection | 7 |
| 2.3 | Electrical characteristics | 8 |
| 2.4 | Electrical characteristics curves | 13 |
| 3 | Test circuit and waveforms plot | 17 |
| 3.1 | Load regulation | 17 |
| 4 | Application information | 18 |
| 4.1 | Voltage regulator | 19 |
| 4.2 | Output current limitation | 19 |
| 4.3 | Output voltage selection | 20 |
| 4.4 | Enable | 21 |
| 4.5 | Reset | 22 |
| 4.6 | Autonomous watchdog | 22 |
| 4.7 | Thermal warning and thermal shutdown | 23 |
| 4.8 | Overvoltage detection by advanced thermal warning read-out | 24 |
| 4.9 | Fast output discharge | 25 |
| 4.10 | Undervoltage lockout UVLO | 25 |
| 4.11 | Functional safety management | 26 |
| 5 | Application | 28 |
| 6 | Package and PCB thermal data | 29 |
| 6.1 | PowerSSO-12 Thermal data | 29 |
| 6.2 | SO-8 thermal data | 32 |
| 7 | Package information | 35 |
| 7.1 | PowerSSO-12 package information | 35 |
| 7.2 | SO-8 package information | 36 |

| | | |
|----------|--|-----------|
| 7.3 | PowerSSO-12 packaging information..... | 38 |
| 7.4 | SO-8 packaging information | 39 |
| 8 | Order codes | 40 |
| | Revision history | 41 |
| | Contents | 42 |
| | List of tables | 44 |
| | List of figures..... | 45 |

List of tables

| | | |
|------------------|--|----|
| Table 1. | Pins description | 4 |
| Table 2. | Absolute maximum ratings | 6 |
| Table 3. | Operation junction temperature | 7 |
| Table 4. | Temperature threshold | 7 |
| Table 5. | Electrical characteristics | 8 |
| Table 6. | Fast output discharge | 10 |
| Table 7. | Reset | 10 |
| Table 8. | Watchdog (only for L99VR01J) | 11 |
| Table 9. | Enable | 11 |
| Table 10. | Output voltages selectors | 11 |
| Table 11. | Thermal warning and protection (only for L99VR01J) | 11 |
| Table 12. | Truth table | 20 |
| Table 13. | Watchdog timer | 23 |
| Table 14. | Safety requirement. | 26 |
| Table 15. | Implemented safety mechanism. | 26 |
| Table 16. | PowerSSO-12 thermal parameter | 31 |
| Table 17. | SO-8 thermal parameter | 34 |
| Table 18. | PowerSSO-12 package mechanical data | 35 |
| Table 19. | SO-8 package mechanical data | 36 |
| Table 20. | Document revision history | 41 |

List of figures

| | | |
|-------------------|--|----|
| Figure 1. | Functional block diagram of L99VR01S | 3 |
| Figure 2. | Functional block diagram of L99VR01J | 4 |
| Figure 3. | Pins configuration | 5 |
| Figure 4. | Output voltage vs Tj | 13 |
| Figure 5. | Output voltage vs VS | 13 |
| Figure 6. | Drop voltage vs output current | 13 |
| Figure 7. | Current consumption vs output current | 13 |
| Figure 8. | Current consumption vs input voltage (I _o < 1mA) | 13 |
| Figure 9. | Current consumption vs input voltage (I _o = 50 mA) | 13 |
| Figure 10. | Current consumption vs input voltage (I _o = 100 mA) | 14 |
| Figure 11. | Short-circuit current vs Tj (Ishort pin floating) | 14 |
| Figure 12. | Short-circuit current vs Tj (Ishort pin tied to GND) | 14 |
| Figure 13. | Short-circuit current vs input voltage | 14 |
| Figure 14. | Output voltage vs enable voltage (V _O =0.8 V) | 14 |
| Figure 15. | Output voltage vs enable voltage (V _O =1.2 V) | 14 |
| Figure 16. | Output voltage vs enable voltage (V _O =1.5 V) | 15 |
| Figure 17. | Output voltage vs enable voltage (V _O =1.8 V) | 15 |
| Figure 18. | Output voltage vs enable voltage (V _O =2.5 V) | 15 |
| Figure 19. | Output voltage vs enable voltage (V _O =2.8 V) | 15 |
| Figure 20. | Output voltage vs enable voltage (V _O =3.3 V) | 15 |
| Figure 21. | Output voltage vs enable voltage (V _O =5 V) | 15 |
| Figure 22. | VEn_high vs Tj | 15 |
| Figure 23. | VEn_low vs Tj | 15 |
| Figure 24. | Vwhth vs Tj | 16 |
| Figure 25. | Vwth vs Tj | 16 |
| Figure 26. | Icwc vs Tj | 16 |
| Figure 27. | Icwd vs Tj | 16 |
| Figure 28. | PSRR | 16 |
| Figure 29. | Load regulation test circuit | 17 |
| Figure 30. | Maximum load variation response | 17 |
| Figure 31. | Application schematic | 18 |
| Figure 32. | Application schematic – Post regulation | 18 |
| Figure 33. | Behavior of output current versus regulated voltage V _o | 19 |
| Figure 34. | Ishort versus Rsh | 20 |
| Figure 35. | Example of output voltage selection | 21 |
| Figure 36. | Typical example of enable control | 21 |
| Figure 37. | Reset timing diagram. | 22 |
| Figure 38. | Watchdog timing diagram. | 23 |
| Figure 39. | Thermal warning diagram. | 24 |
| Figure 40. | Square wave on TW pin generated during an overvoltage | 24 |
| Figure 41. | Warning signal caused by overvoltage and thermal warning on TW pin | 25 |
| Figure 42. | Undervoltage lockout on output voltage | 26 |
| Figure 43. | Typical application. | 28 |
| Figure 44. | PowerSSO-12 PC board | 29 |
| Figure 45. | Rthj-amb vs PCB copper area in open box free air condition (PowerSSO-12) | 30 |
| Figure 46. | PowerSSO-12 thermal impedance junction ambient single pulse. | 30 |
| Figure 47. | Thermal fitting model of a Vreg in PowerSSO-12 | 31 |
| Figure 48. | SO-8 PC board. | 32 |
| Figure 49. | Rthj-amb vs PCB copper area in open box free air condition. | 33 |
| Figure 50. | SO-8 thermal impedance junction ambient single pulse | 33 |
| Figure 51. | Thermal fitting model of a Vreg in SO-8 | 34 |

| | | |
|-------------------|--|----|
| Figure 52. | PowerSSO-12 package dimensions | 35 |
| Figure 53. | SO-8 package dimension | 36 |
| Figure 54. | PowerSSO-12 tape and reel shipment (suffix "TR") | 38 |
| Figure 55. | SO-8 tape and reel shipment (suffix "TR") | 39 |

IMPORTANT NOTICE – PLEASE READ CAREFULLY

STMicroelectronics NV and its subsidiaries (“ST”) reserve the right to make changes, corrections, enhancements, modifications, and improvements to ST products and/or to this document at any time without notice. Purchasers should obtain the latest relevant information on ST products before placing orders. ST products are sold pursuant to ST’s terms and conditions of sale in place at the time of order acknowledgement.

Purchasers are solely responsible for the choice, selection, and use of ST products and ST assumes no liability for application assistance or the design of Purchasers’ products.

No license, express or implied, to any intellectual property right is granted by ST herein.

Resale of ST products with provisions different from the information set forth herein shall void any warranty granted by ST for such product.

ST and the ST logo are trademarks of ST. For additional information about ST trademarks, please refer to www.st.com/trademarks. All other product or service names are the property of their respective owners.

Information in this document supersedes and replaces information previously supplied in any prior versions of this document.

© 2021 STMicroelectronics – All rights reserved

X-ON Electronics

Largest Supplier of Electrical and Electronic Components

Click to view similar products for [LDO Voltage Regulators](#) category:

Click to view products by [STMicroelectronics](#) manufacturer:

Other Similar products are found below :

[AP7363-SP-13](#) [NCV8664CST33T3G](#) [L79M05TL-E](#) [AP7362-HA-7](#) [PT7M8202B12TA5EX](#) [TCR3DF185,LM\(CT](#) [TLF4949EJ](#)

[NCP4687DH15T1G](#) [NCV8703MX30TCG](#) [LP2951CN](#) [NCV4269CPD50R2G](#) [AP7315-25W5-7](#) [AP2111H-1.2TRG1](#) [ZLDO1117QK50TC](#)

[AZ1117ID-ADJTRG1](#) [NCP114BMX075TCG](#) [MC33269T-3.5G](#) [TLE4471GXT](#) [AP7315-33SA-7](#) [NCV4266-2CST33T3G](#) [NCP715SQ15T2G](#)

[NCV8623MN-50R2G](#) [NCV8664CDT33RKG](#) [NCV4299CD250R2G](#) [NCP715MX30TBG](#) [NCV8702MX25TCG](#) [L974113TR](#) [TLE7270-2E](#)

[NCV562SQ25T1G](#) [AP2202K-2.6TRE1](#) [NCV8170BMX300TCG](#) [NCV8152MX300180TCG](#) [NCP700CMT45TBG](#) [AP7315-33W5-7](#)

[LD56100DPU28R](#) [NCP154MX180300TAG](#) [AP2113AMTR-G1](#) [NJW4104U2-33A-TE1](#) [MP2013AGG-5-P](#) [NCV8775CDT50RKG](#)

[NJM2878F3-45-TE1](#) [S-1313D18-N4T1U4](#) [AP7343D-31FS4-7B](#) [AP7315D-33FS4-7B](#) [AP7315-30W5-7](#) [AZ1117ID-1.2TRG1](#)

[XC6215B3027R-G](#) [XC6216C201MR-G](#) [XC6233H181GR-G](#) [XC6504A2019R-G](#)