

INDUSTRIAL LOCKING SYSTEMS



ROZTOCZE



APPLICATION SECTORS



ENERGY INDUSTRY



Steel Clamps



Swinghandles



RAILWAY TRANSPORT



Locks



Stainless Steel Hinges



ICT



Concealed Hinges



Mechatronic Locks



HVAC INDUSTRY



Sealing Profiles



TRANSPORTATION INDUSTRY



Vibration Resistant Locks



Joint hinges



MACHINE INDUSTRY



Toggle Latches



Handles



Roztocze is a leading manufacturer of industrial closures in Europe. We offer our customers a wide range of products such as: locks, hinges, clamps, latches, gaskets, handles and customized solutions. Our as-

sortment is used in the power industry, telecommunications, HVAC, construction, railways, automotive, machinery, marine and road industries.

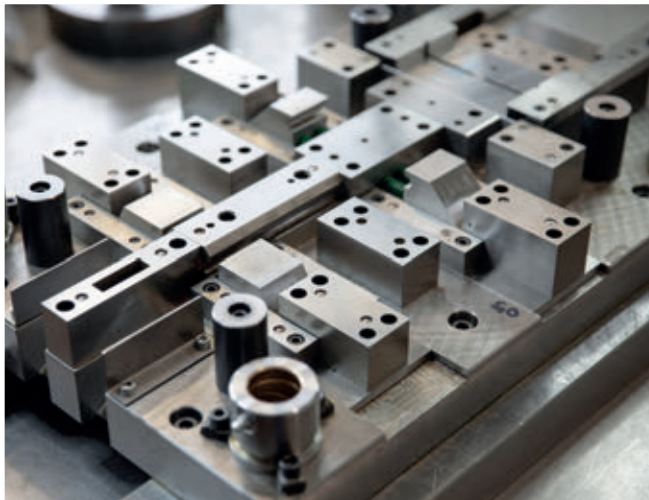

Since the beginning of its activity, the company has been focused on individual customer needs and industry demands for almost 30 years. Using our experience, modern machine park with CNC machi-

ne tools and our own Tool Room, we provide a broad range of design solutions trying to ensure that our ideas meet the needs of the market.

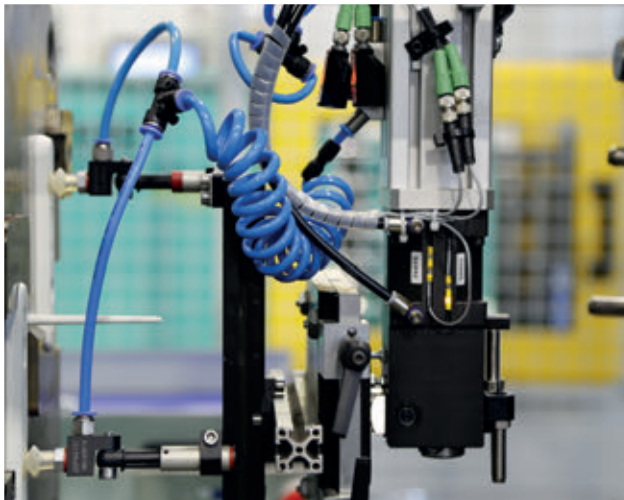
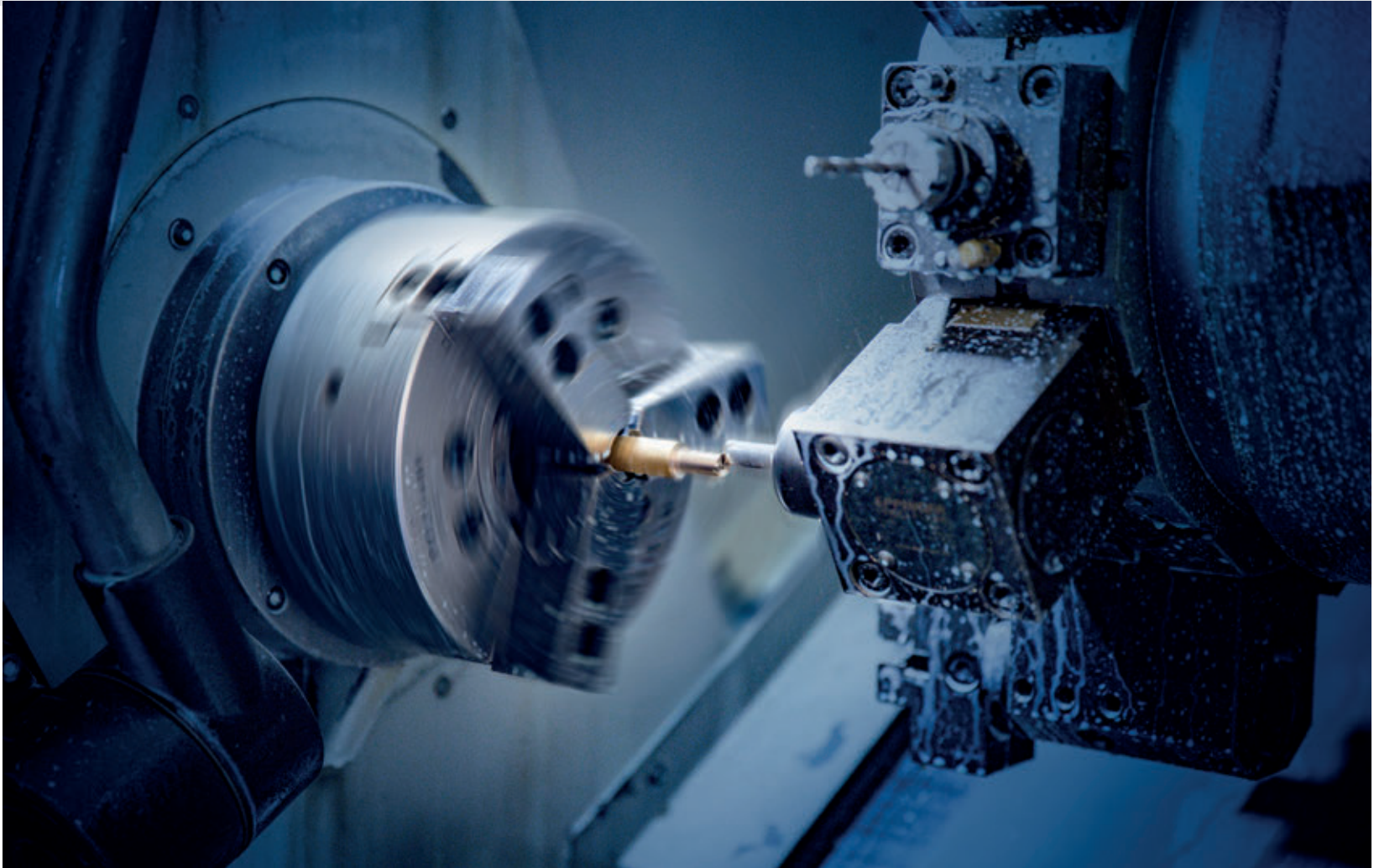

In our offer there are over 5,000 products manufactured in the Polish location in Tomaszów Lubelski. We employ over 760 people on 20 000 m² of production area and use over 300 CNC numerical machines.

The support we provide to our business partners at the technological level allows them to gain market advantage and build brands of their products based on technological and quality-oriented features.



We achieve the highest quality of services by monitoring and auditing ISO 9001 quality systems and the knowledge and skills of our team.

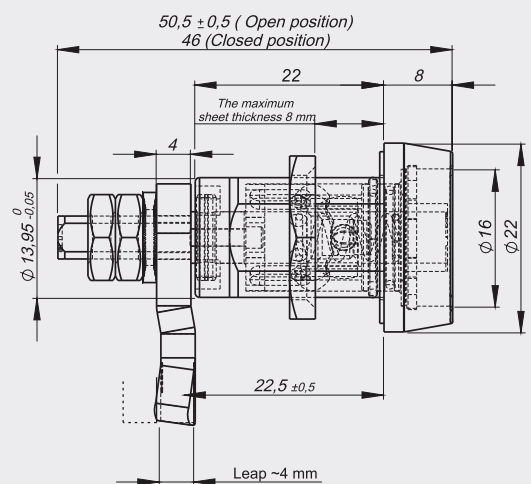
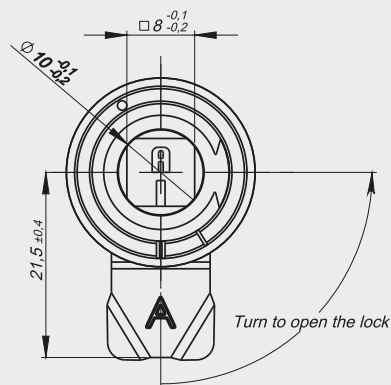

With the use of modern technologies, we offer our customers professional technological and engineering support in the areas of foundry of zinc alloys (ZAMAK),

plastic injection, CNC machining, plastic and laser sheet metal processing, die-cutting and injection moulding as well as final machining.

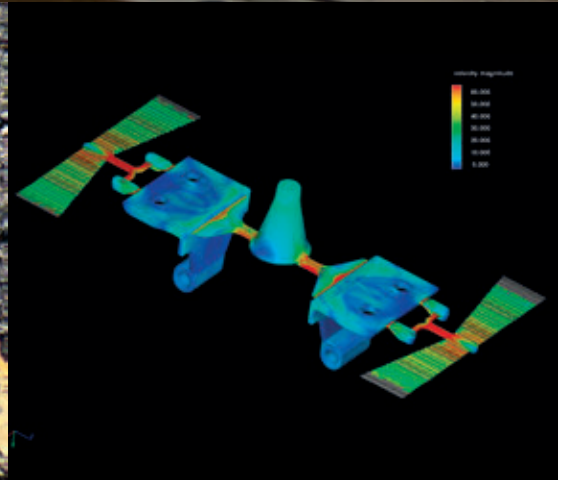
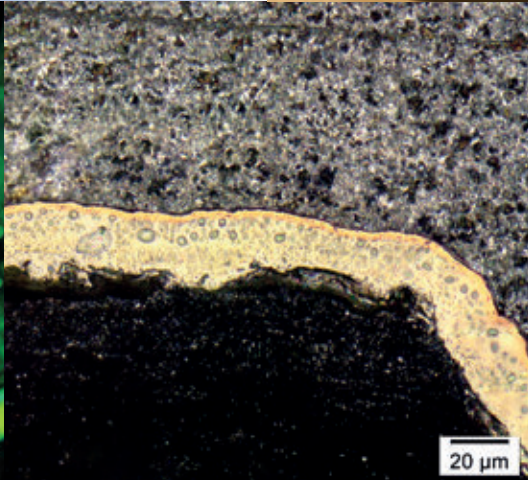
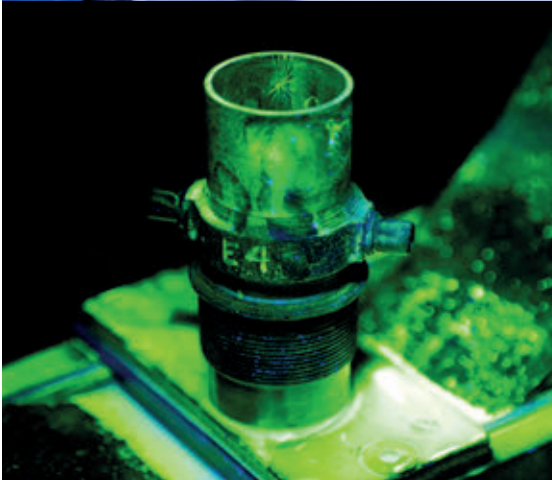

Our Research and Development Centre offers services in the field of microscopic and macroscopic examination of steels and plastics. We provide services of metallographic testing, chemical composition analysis, defectoscopic testing of material faults as well as re-

sistance of metals and protective coatings according to DIN 50021, ASTM B117, ASTM G85, EN ISO 9227 in salt chambers, climatic chambers and strength testing in the range from 10 N to 100 N.

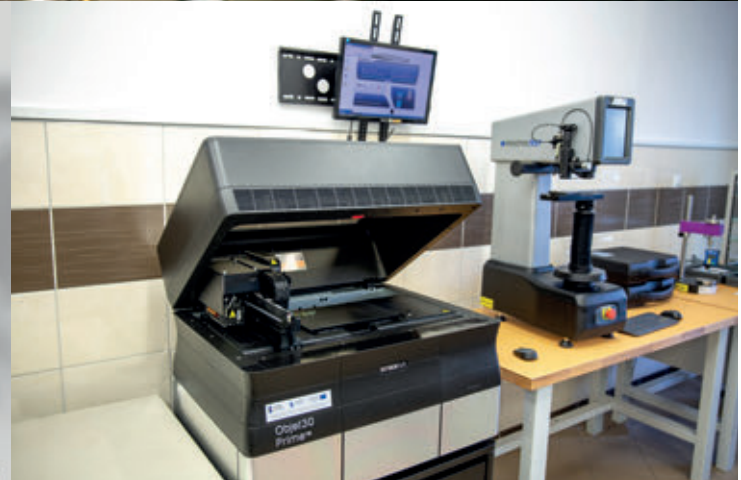
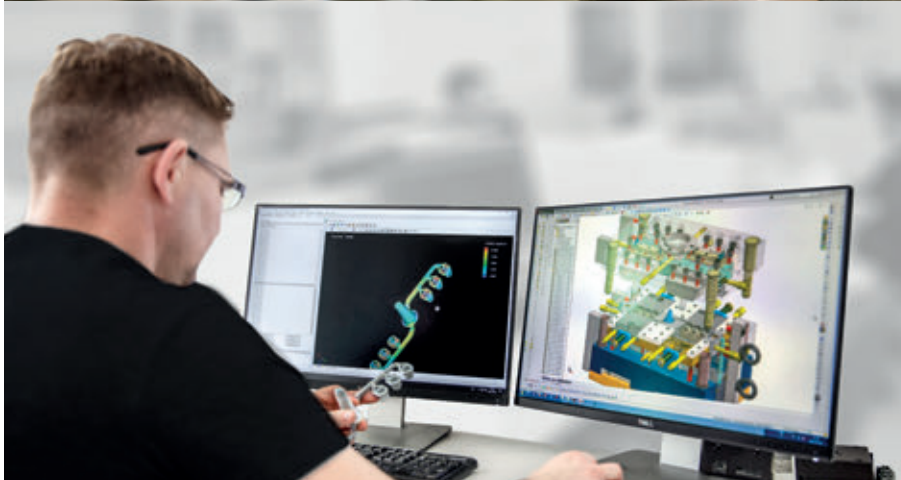
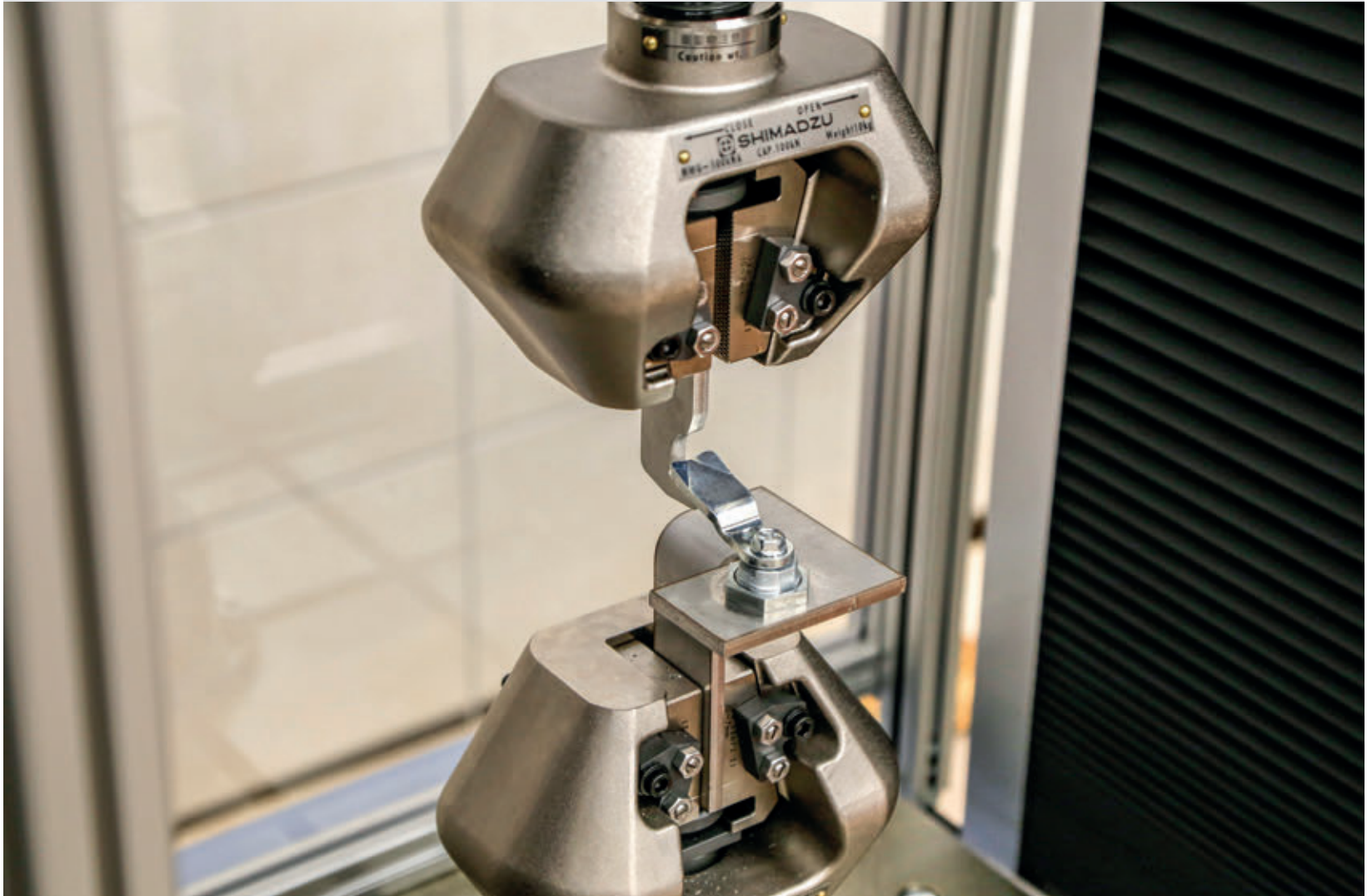





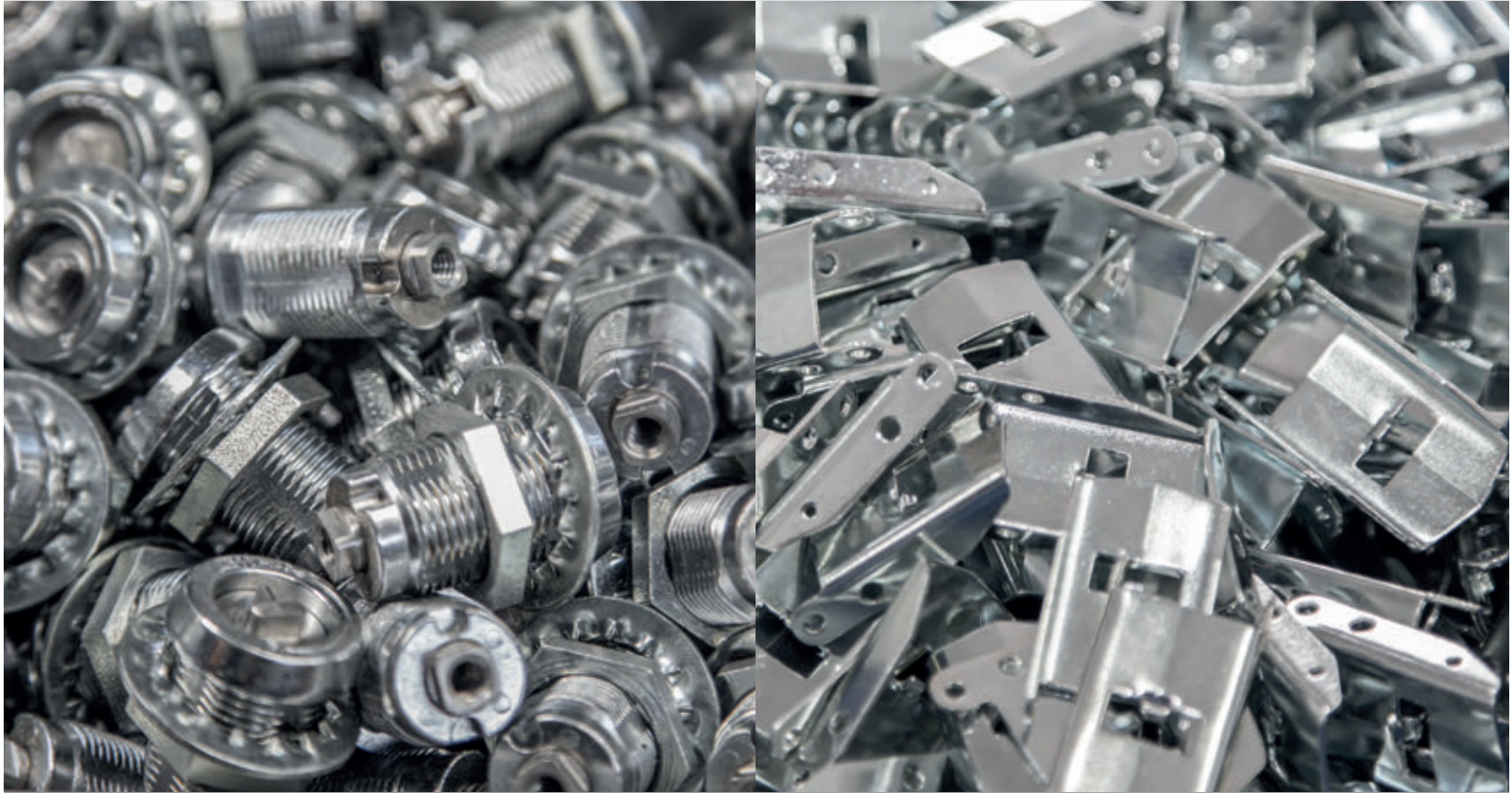













In the laboratory of prototypes we test a number of structures of locking systems. We examine, among others, the resistance to static loads and shear strength of hinges according to the PN-EN 1935 standard. While analyzing the properties and functionality of the struc-

ture, we are searching for possibilities of improving a given solution. We use 3D printing in Poly Jet technology which enables us to print prototype details from transparent materials having elastomer properties and high-temperature materials HDT min. 50°.



					1 Locking systems
					2 Locks Latches
					3 Hinges
					4 Clamps
					5 Accessories
					6 Gasketing profiles
					7 Custom products

	New		Stainless steel
	Standard RoHS		The use left / right
	1-point system		The use right
	2-point system		The use left
	3-point system		Version with padlock
	X, Y and Z axis adjustment		Degree of protection IP 55
	X and Y axis adjustment		Degree of protection IP 65
	X-axis adjustment (horizontal)		Degree of protection IP 66
	Y-axis adjustment (vertical)		Degree of protection IP 69K
			Opening angle

Finishing type [C]										
ZAMAK 5							Polyamide		Stainless steel	
Chrome	Nickel	Galvanized	RAL 9005	RAL 7035	KTL	No coating	RAL 9005	RAL 7035	304	316
01	02	03	04	05	06	0	07	08	9.1	9.2

Clarification of version LH and RH

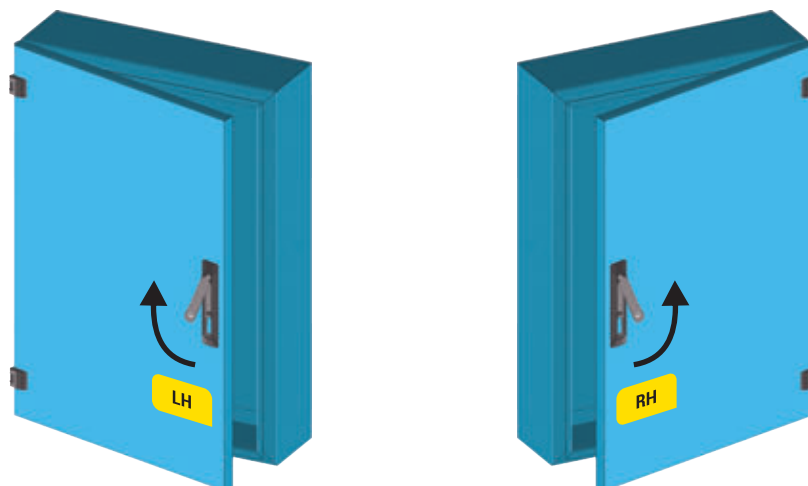

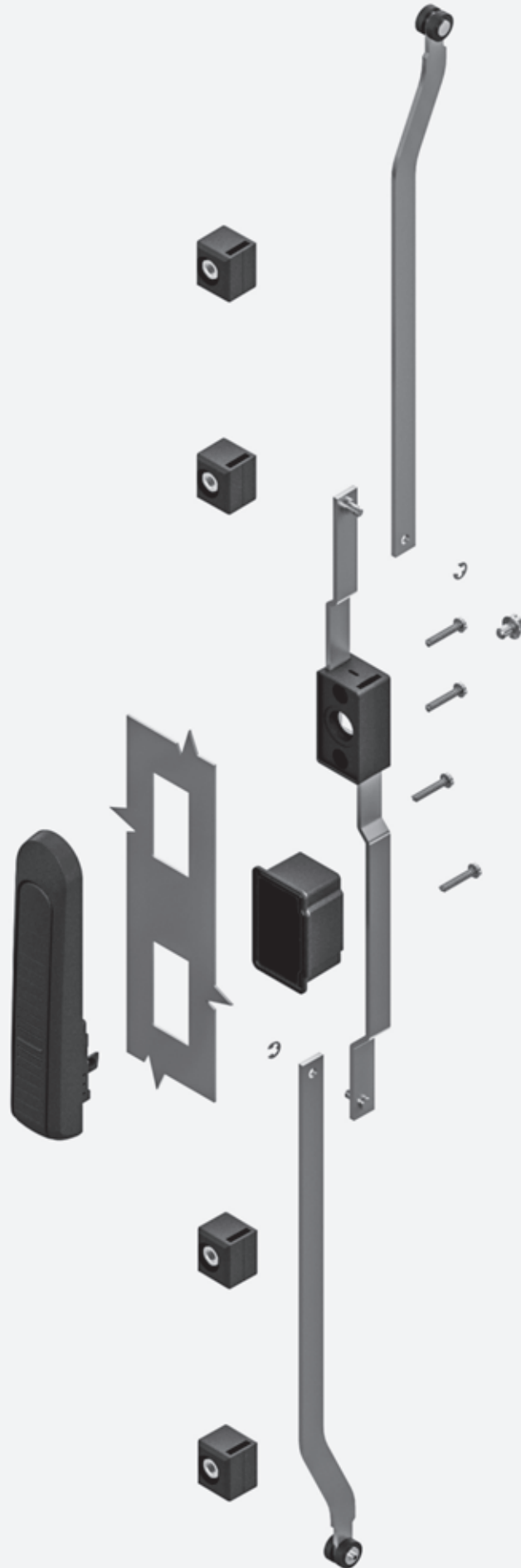

1

Locking systems

2

Locks
Latches

3

Hinges

4

Clamps

5

Accessories

6

Gasketing profiles

7

Custom products

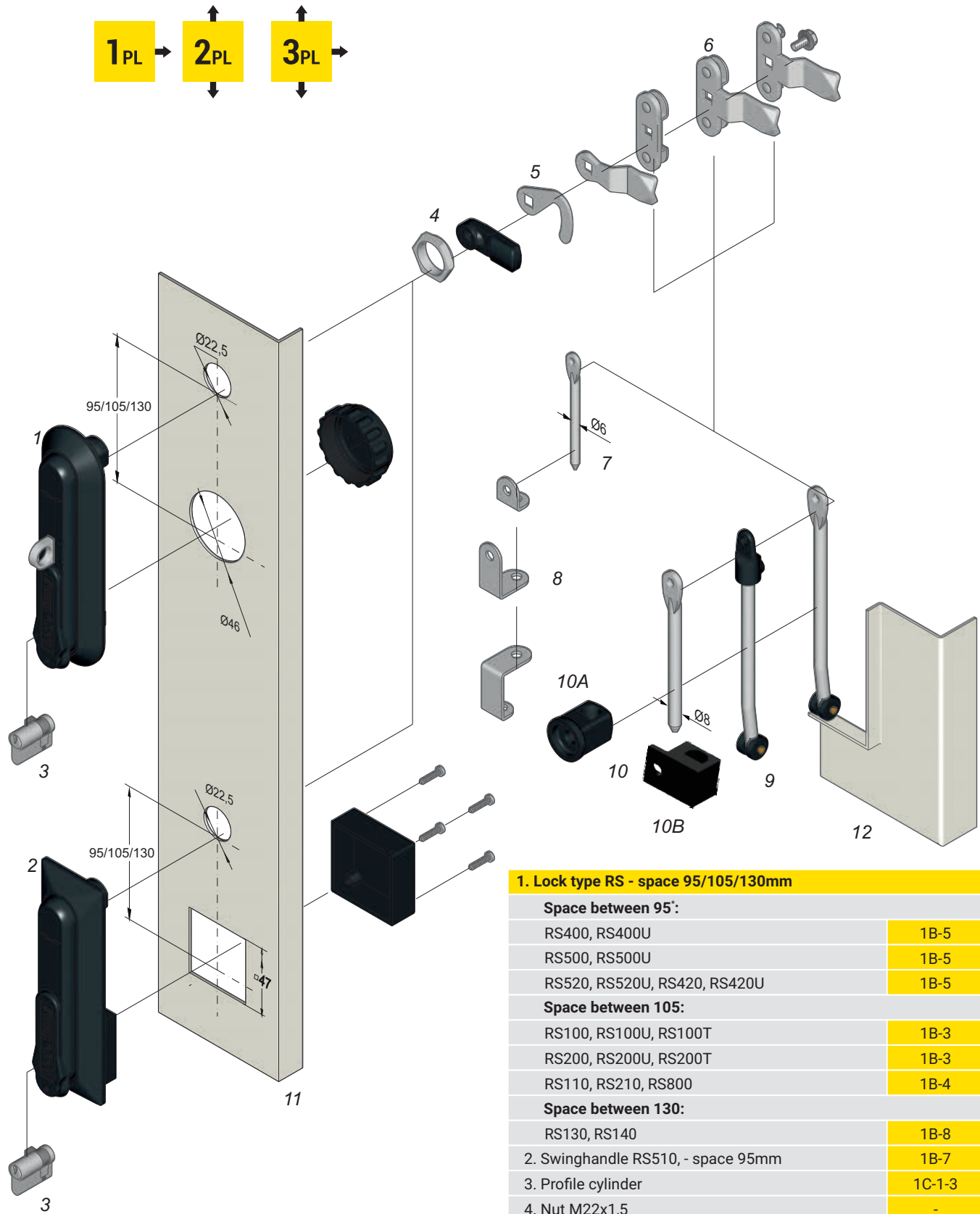

1. Lock type RS - space 95/105/130mm

Space between 95':	
RS400, RS400U	1B-5
RS500, RS500U	1B-5
RS520, RS520U, RS420, RS420U	1B-5
Space between 105':	
RS100, RS100U, RS100T	1B-3
RS200, RS200U, RS200T	1B-3
RS110, RS210, RS800	1B-4
Space between 130':	
RS130, RS140	1B-8
2. Swinghandle RS510, - space 95mm	1B-7
3. Profile cylinder	1C-1-3
4. Nut M22x1,5	-
5. 1-point cam without limiter	1C-12-13
6. 2-points, 3-points cam without limiter	1C-15, 19
7. Rod $\varnothing 6$	1C-4
8. Rod guide $\varnothing 6$	1C-6
9. Rod $\varnothing 8$	1C-4-5
10A. Rod guide $\varnothing 8$ 10B. Rod guide RW	1C-6-7
11. Door of the box	-
12. Edge of the box	-

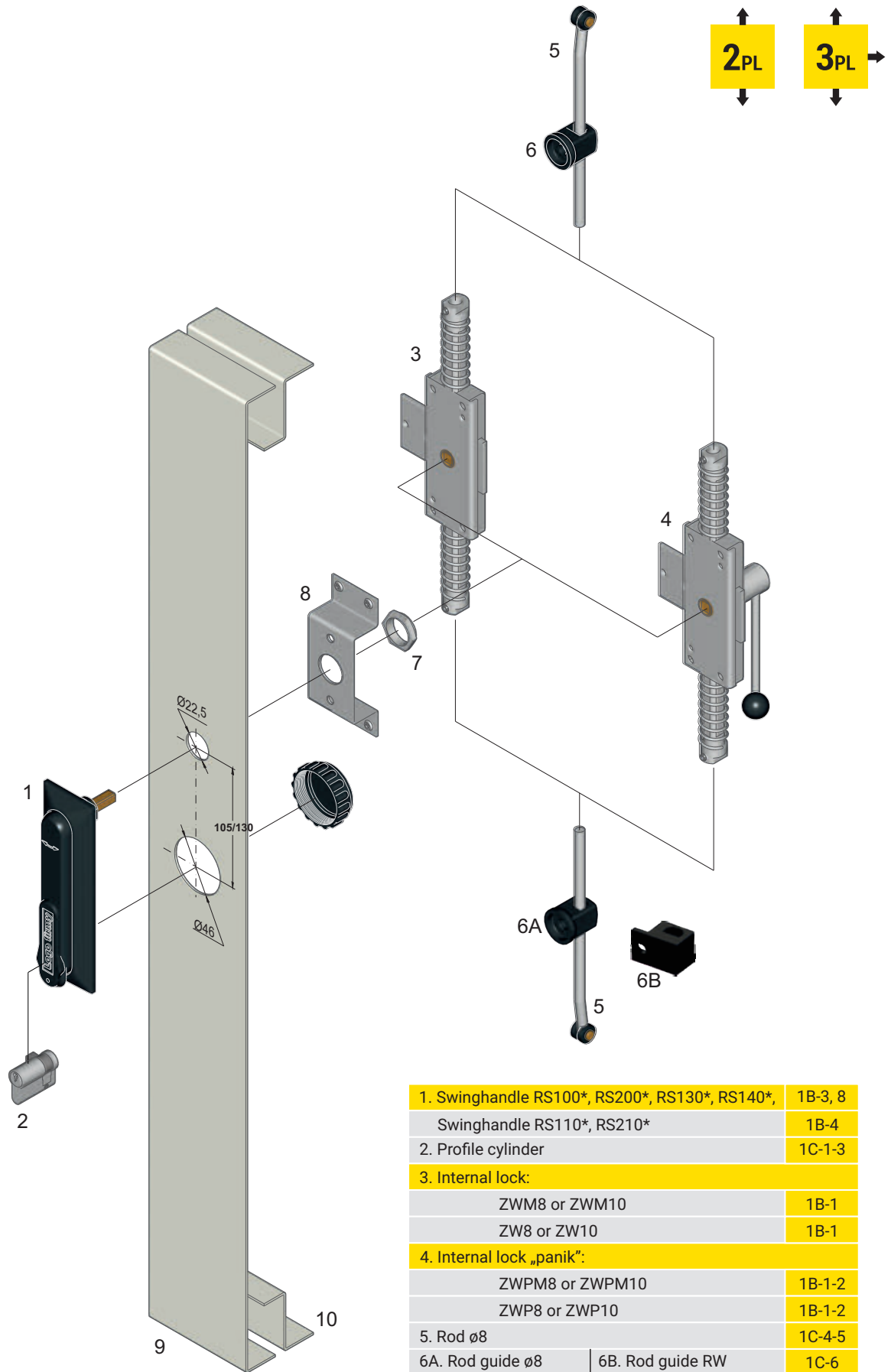

1. Swinghandle RS100*, RS200*, RS130*, RS140*,	1B-3, 8
Swinghandle RS110*, RS210*	1B-4
2. Profile cylinder	1C-1-3
3. Internal lock:	
ZWM8 or ZWM10	1B-1
ZW8 or ZW10	1B-1
4. Internal lock „panik“:	
ZWPM8 or ZWPM10	1B-1-2
ZWP8 or ZWP10	1B-1-2
5. Rod ø8	1C-4-5
6A. Rod guide ø8	6B. Rod guide RW
	1C-6
7. Nut M22 x 1,5	-
8. Lock support*	-
9. Door of the box	-
10. Edge of the box	-

(*) **When you order locks RS100, RS110, RS200, RS210, RS130, RS140 to Internal lock**, you should add letters ZW e.e (RS100ZW, RS200ZW). **When you order locks RS100, RS110, RS200, RS210 to Internal lock panik**, you should add letters ZWP e.g. (RS100ZWP) **Lock support** only on special request.

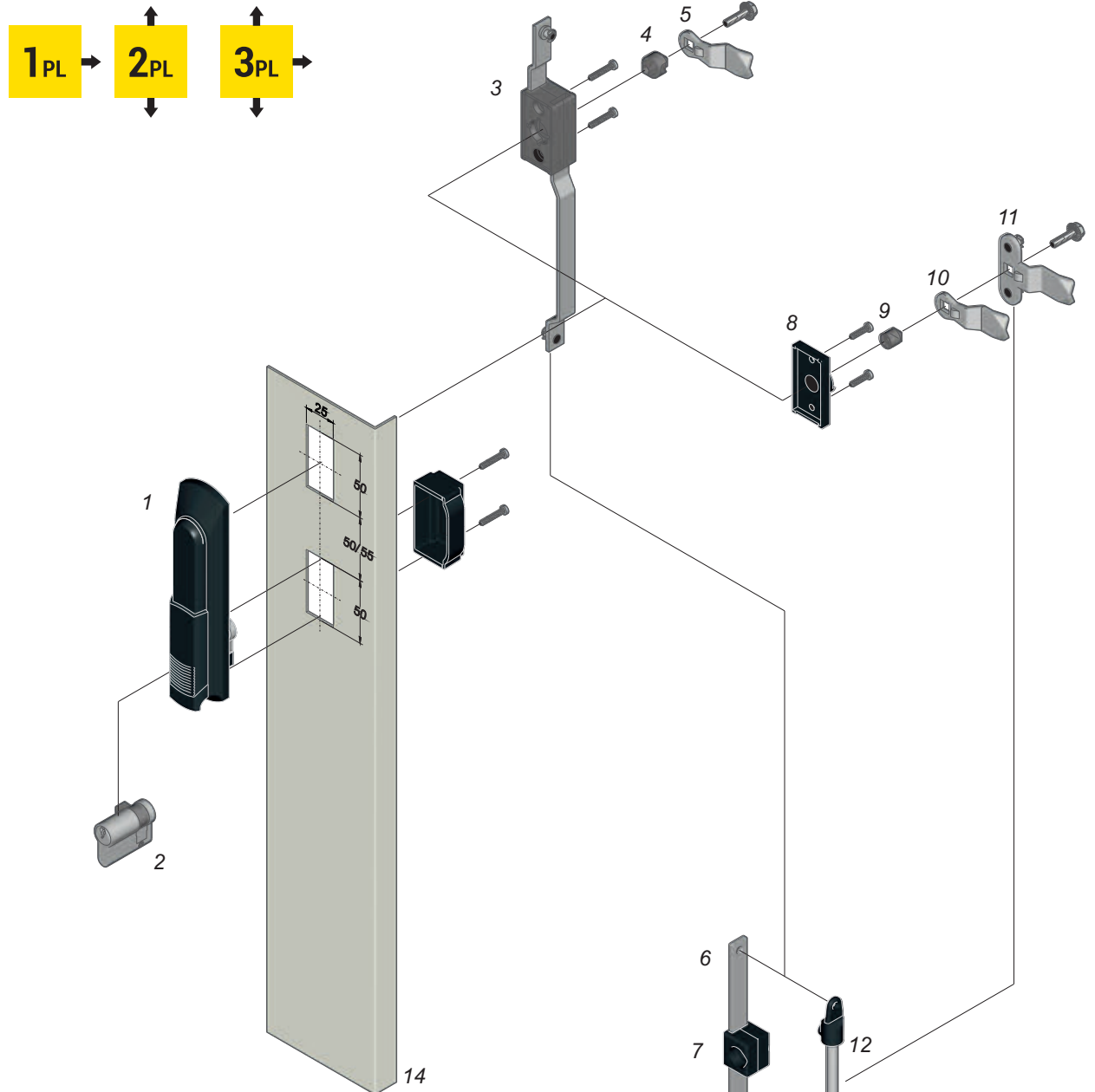

1. Lock RS - space 50/55 mm	-
Space between holes 50x50x50	
1B-9 to 1B-31	
Space between holes 50x55x50	
RS300	1B-23
2. Profile cylinder	1C-1-3
3. Cogwheel mechanism	1C-30-31
4. Adapter	1C-27
5. 1-point cam with limiter	1C-9-11
6. Flat rod with rollers	1C-34
7. Flat rod guide P314	1C-8
8. Cap	1C-27
9. Bushing	1C-27
10. 1-point cam with limiter for cap	1C-10-11
11. 3-point cam with limiter for cap	1C-16-18
12. Rod $\varnothing 8$, rod holder	1C-5
13. Rod guide $\varnothing 8$	1C-6-7
14. Door of the box	-
15. Edge of the box	-

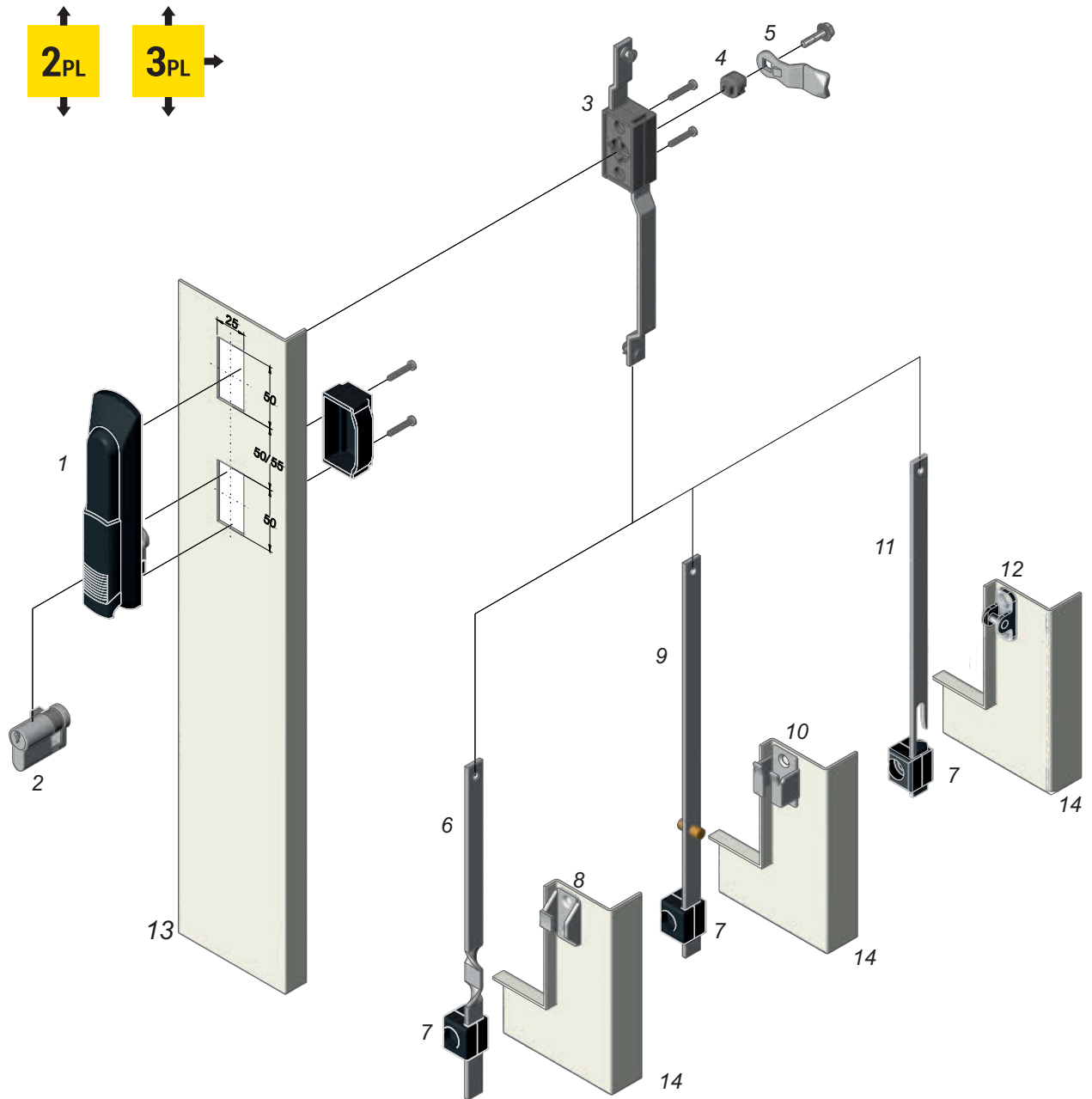

1. Swinghandle RS - space 50/55 mm	-
Space between holes 50x50x50	
1B-9 To 1B-31	
Space between holes 50x55x50	
RS300	1B-23
2. Profile cylinder	1C-3
3. Cogwheel mechanism	1C-30-31
4. Adapter	1C-27
5. 1-point cam with limiter	1C-9-11
6. Flat rod ver. "A", "B", "C"	1C-36
7. Flat rod guide P314	1C-8
8. Catch W314-90	1C-36
9. Flat rod ver. "B"	1C-37
10. Catch W314-80	1C-38
11. Flat rod ver. "C"	1C-39
12. Catch W314-70	1C-39
13. Door of the box	-
14. Edge of the box	-

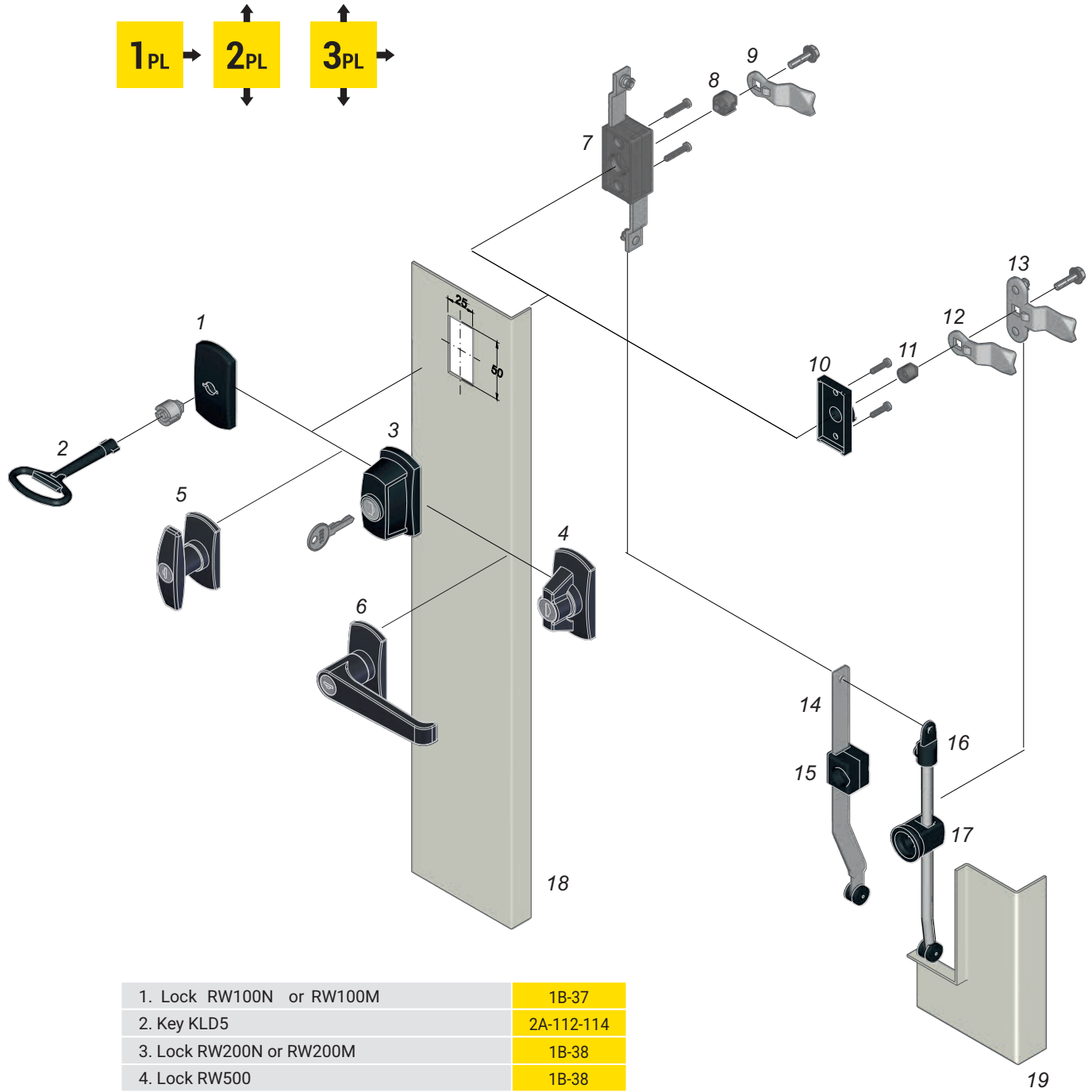

1. Lock RW100N or RW100M	1B-37
2. Key KLD5	2A-112-114
3. Lock RW200N or RW200M	1B-38
4. Lock RW500	1B-38
5. T-handle lock	1B-40
6. L-handle lock	1B-40
7. Cogwheel mechanism	1C-28
8. Adapter	1C-27
9. 1-point cam with limiter	1C-9-11
10. Cap	1C-27
11. Bushing	1C-27
12. 1-point cam with limiter for cap	1C-10-11
13. 3-point cam with limiter for cap	1C-17-18
14. Flat rod with rollers	1C-34
15. Flat rod guide P314	1C-8
16. Rod ø8, rod holder	1C-5
17. Rod guide ø8	1C-6-7
18. Door of the box	-
19. Edge of the box	

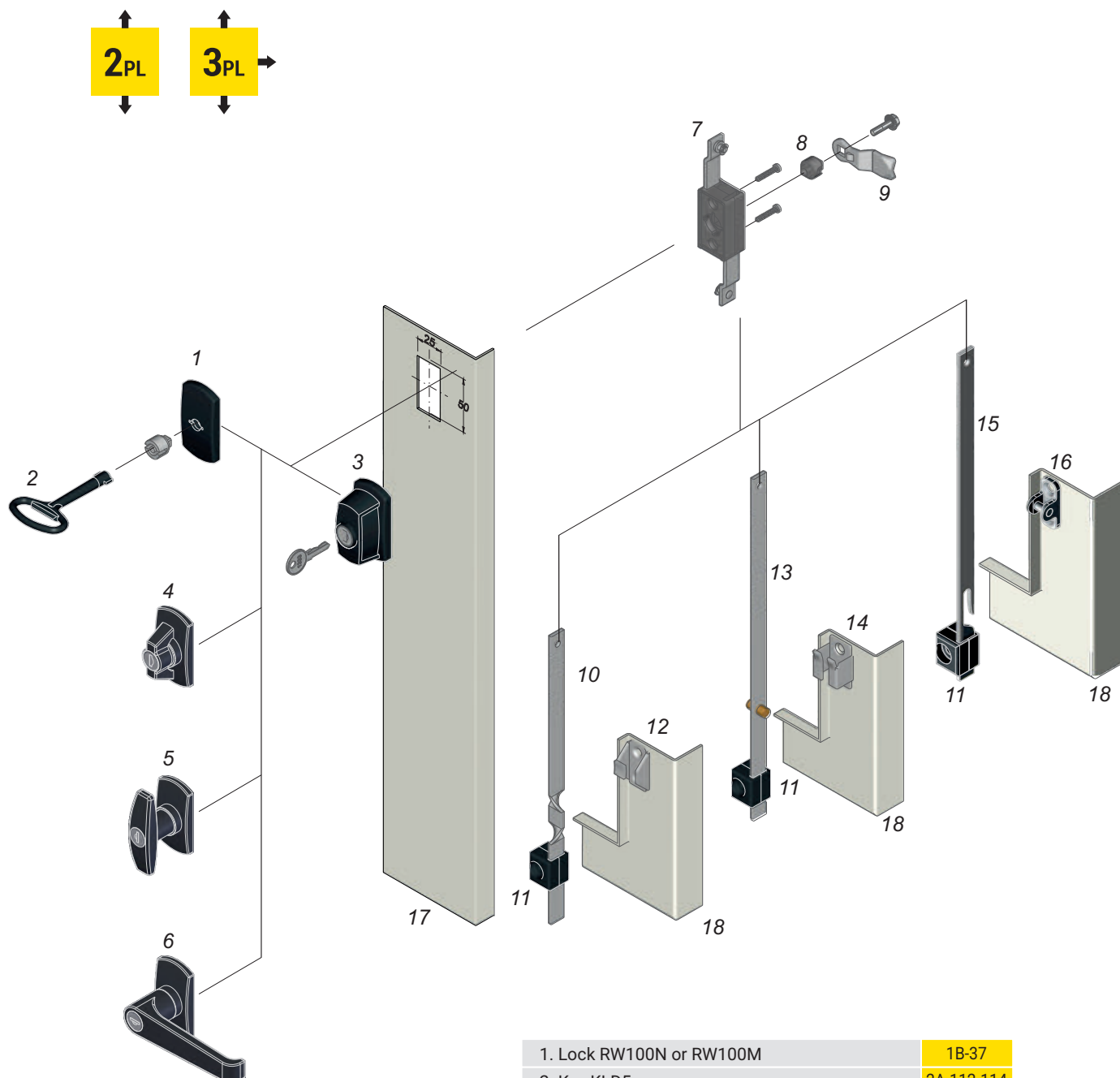

1. Lock RW100N or RW100M	1B-37
2. Key KLD5	2A-112-114
3. Lock RW200N or RW200M	1B-38
4. Lock RW500	1B-38
5. T-handle locking	1B-40
6. L-handle locking	1B-40
7. Cogwheel mechanism	1C-28
8. Adapter	1C-27
9. 1-point cam with limiter	1C-9-11
10. Flat rod ver. "A"	1C-36
11. Flat rod guide P314	1C-8
12. Catch W314-90	1C-36
13. Flat rod ver. "B"	1C-37
14. Catch W314-80	1C-38
15. Flat rod ver. "C"	1C-39
16. Catch W314-70	1C-39
17. Door of the box	-
18. Edge of the box	-

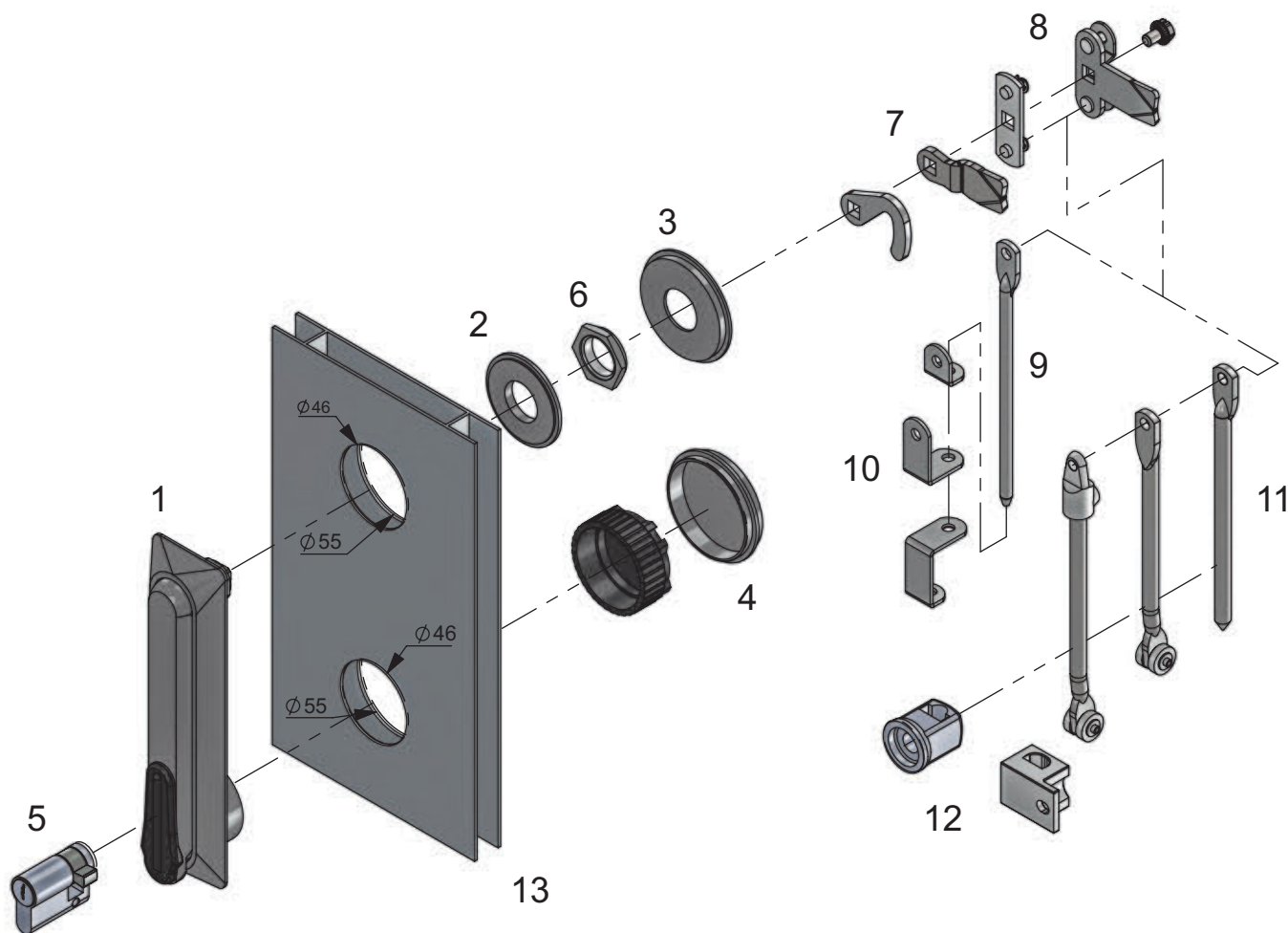

1. Swinghandle RS130, RS140	1B-8
2. Adapter 1C.916.001	1C-43
3. Adapter 1C.916.002	1C-43
4. Adapter 1C.916.003	1C-43
5. Profile	1C-1-3
6. Nut M22x1,5	-
7. Cam 1-point no limiter	1C-12-13
8. Cam 2-point, 3-point no limiter	1C-15-19
9. Rod 6	1C-4
10. Rod guide 6	1C-6
11. Rod 8 1C-3,4	1C-5
12. Rod guide 8 / Rod guide RW	1C-6-7
13. Cabinet door	-

2PL

BOLT MECHANISM

BOLT

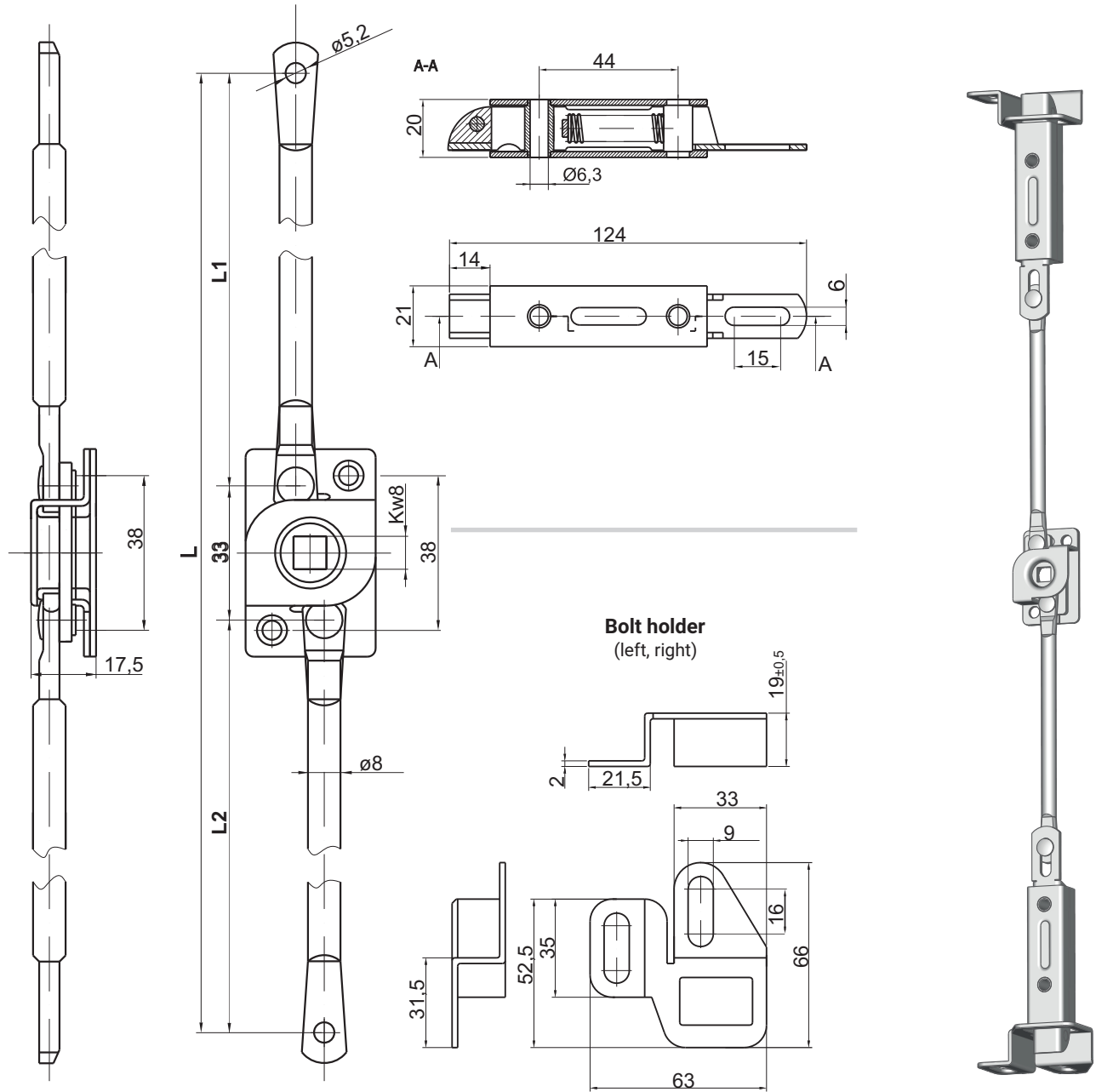

$$L = 33 + L_1 + L_2$$

CAT. NUMBER	NAME	MATERIAL
1A.001.001	Bolt mechanism	Steel zinc plated
1A.001.001SN	Bolt mechanism	Stainless steel
1A.002.001	Bolt	Steel zinc plated
1A.002.001SN	Bolt	Stainless steel
1A.003.001	Bolt holder right	Stainless steel
1A.003.002	Bolt holder left	Stainless steel

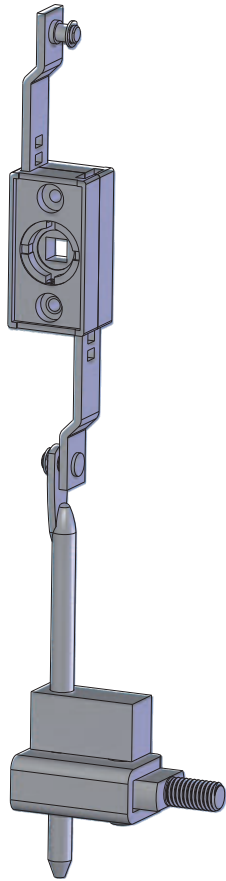

ROD STRENGHTENING SYSTEM

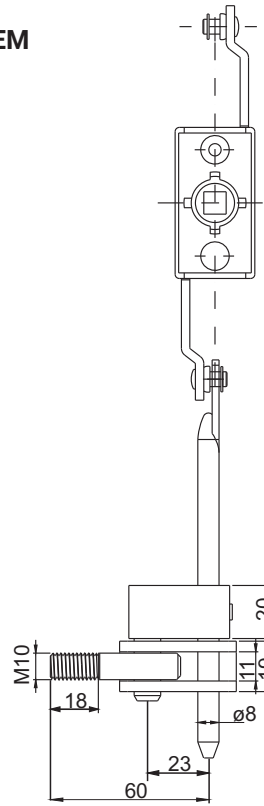

COGWHEEL MECHANISM DISTANCE

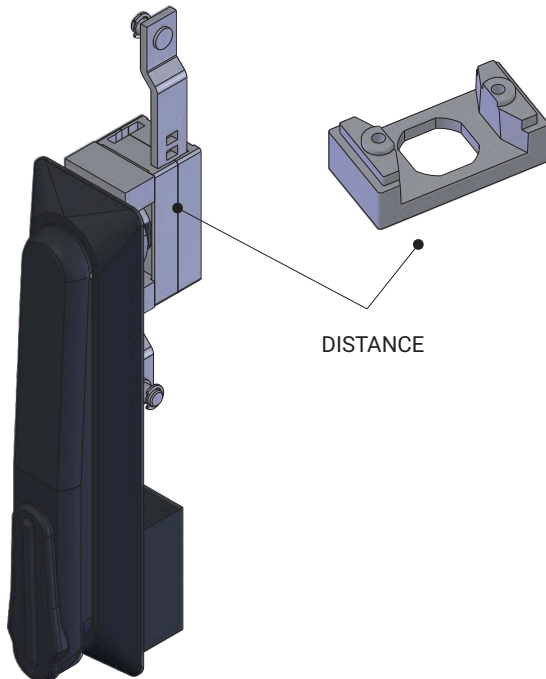

DISTANCE

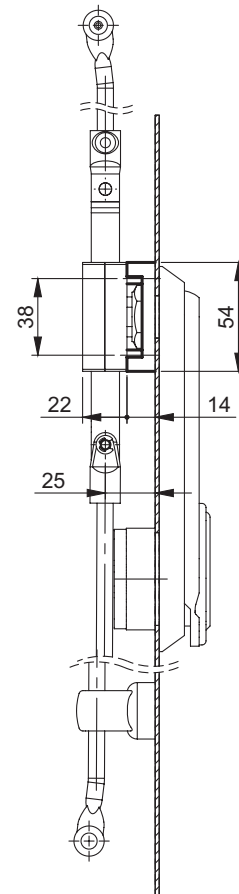

CAT. NUMBER	NAME	MATERIAL
1C.911.001	Rod strenghtening system	Steel zinc plated
1C.910.001	Cogwheel mechanism distance	ZAMAK

* system cooperates with cogwheel mechanism MZ (pg 1C-28, 1C-30, 1C-32, 1C-33)

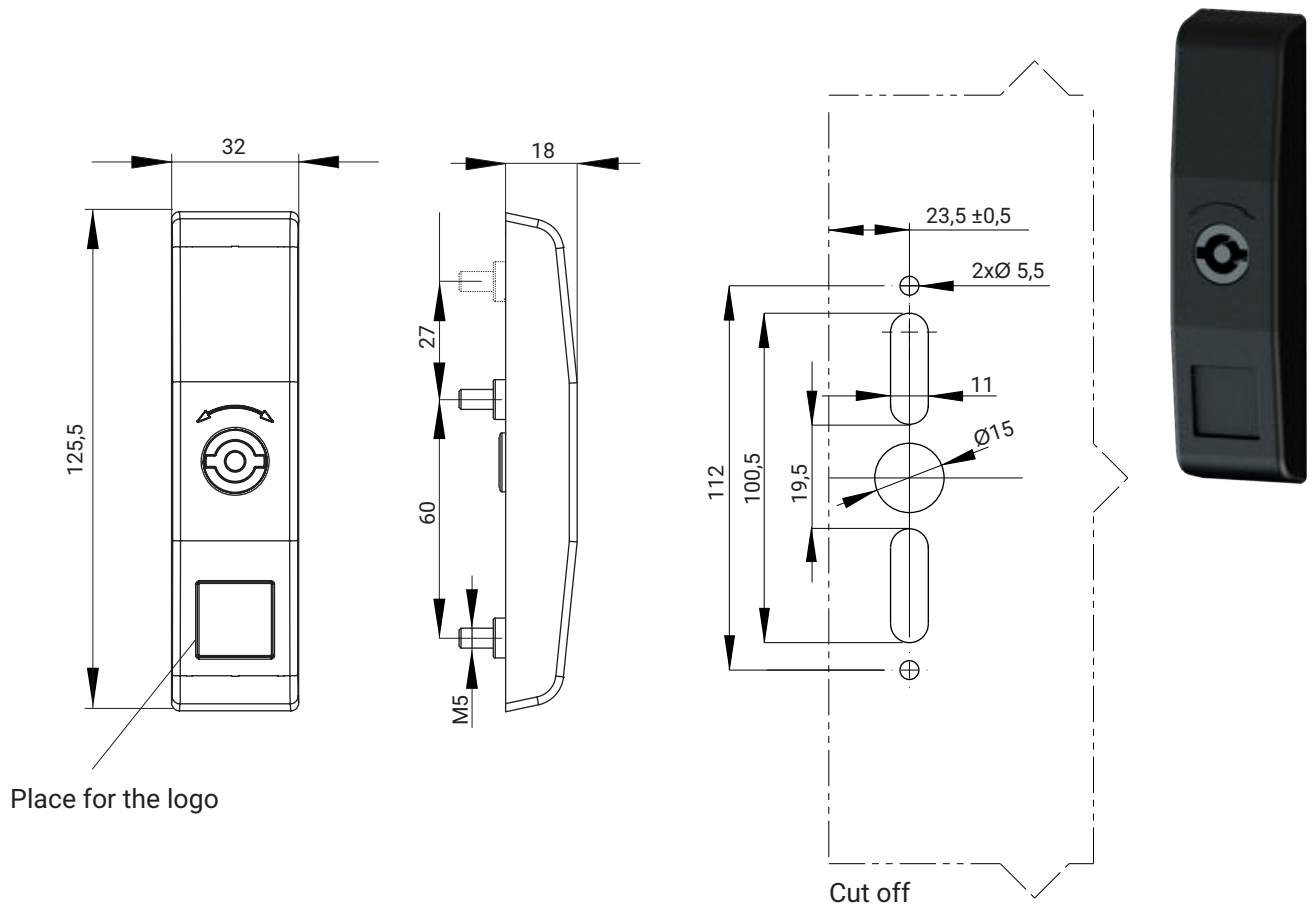

LOCK TYPE	COMPONENTS	MATERIAL	FINISH [C]	
RW 250	Housing	ABS	RAL 9005	RAL 7035
	Flat rods	Steel	04	05

Inserts				
D3	D5	T9	KW 8	S

How to order :

Type of lock
Type of insert
Height cabinet
Finish

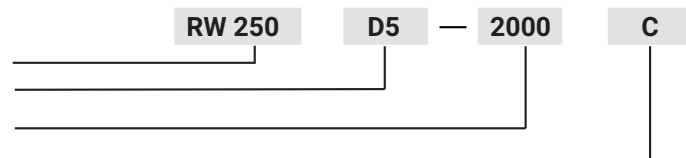

NOTE:

1. Lock RW 250 suitable to use outside the sealing zone
2. Locking system for door about max. thickness 2 mm
3. Type of locking system: left or right.
4. System components sold together or separately

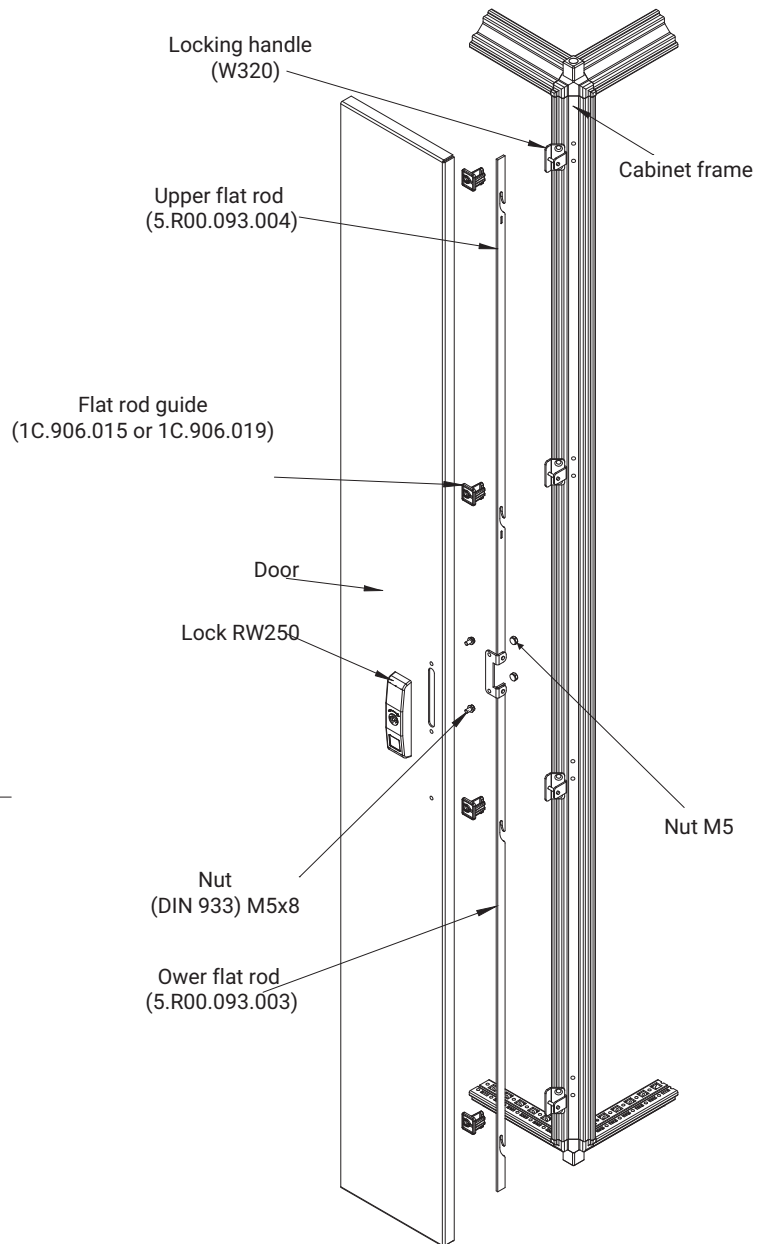
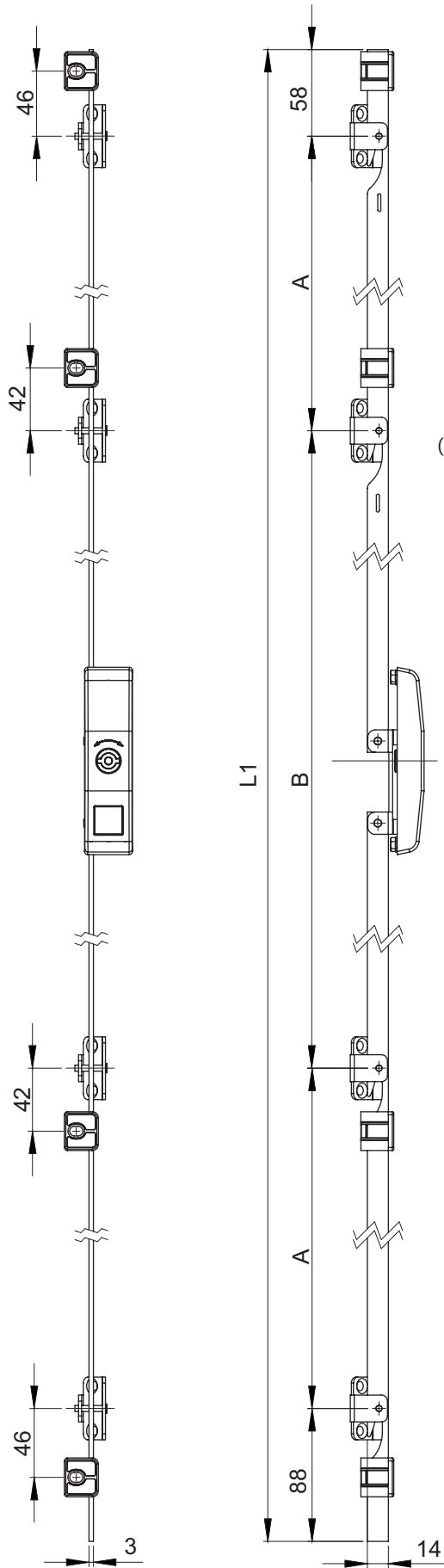

HEIGHT OF THE BOX[L]	L1	A	B
1800	1729	520	520
2000	1929	586	586

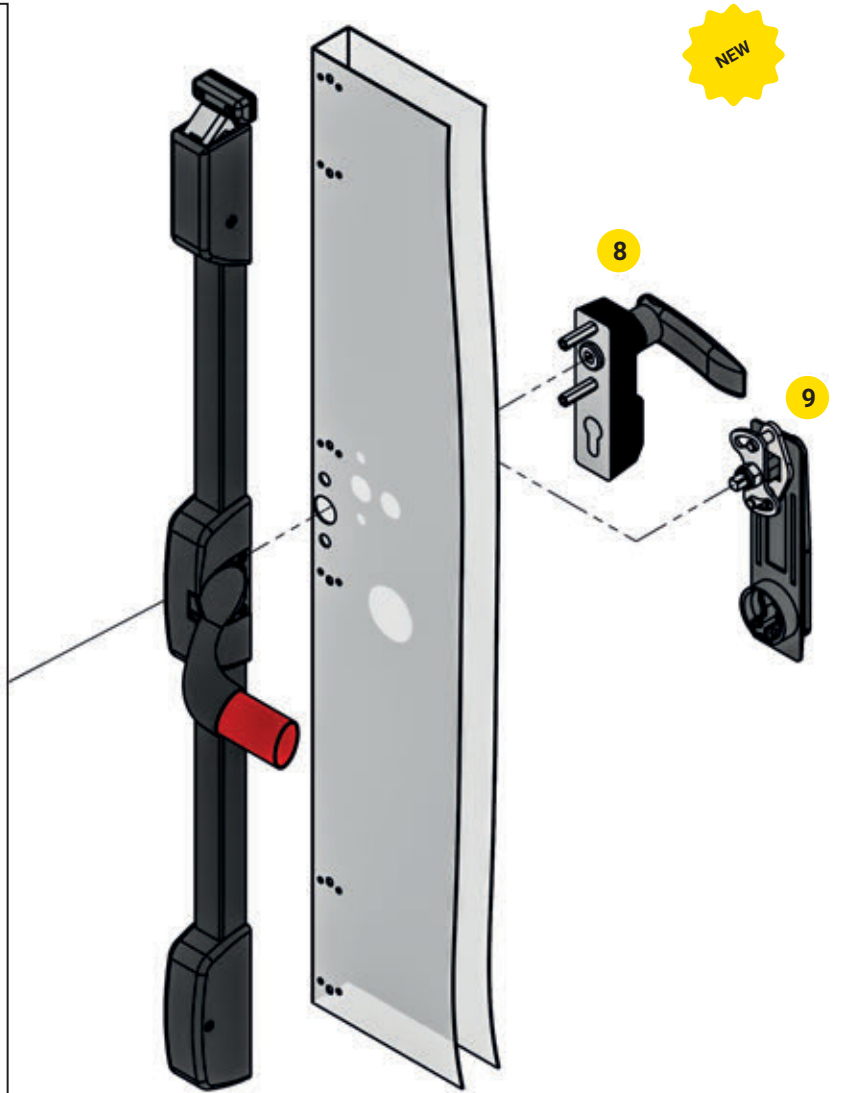
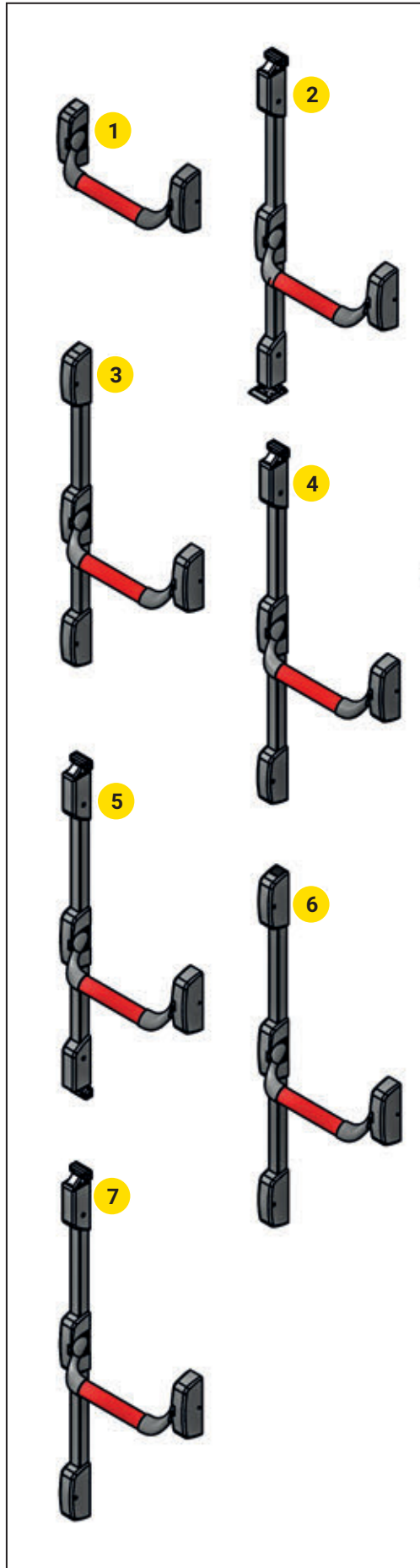

ANTI-PANIC LOCK		
1.	1B.ZA.001	1A-13
2.	1B.ZA.002	1A-14
3.	1B.ZA.003	1A-15
4.	1B.ZA.004	1A-16
5.	1B.ZA.005	1A-17
6.	1B.ZA.006	1A-18
7.	1B.ZA.007	1A-19
COMPATIBLE HANDLES		
8.	1B.ZA.201	1A-21
COMPATIBLE SWINGHANDLES		
9.	RS130 ZA	1A-22
	RS130/U ZA	
	RS200 ZA	1A-22
	RS200/U ZA	

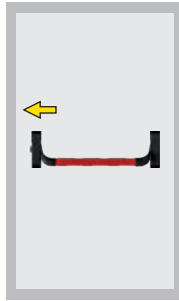

Anti-panic lock SINGLE-POINT HORIZONTAL LATCH

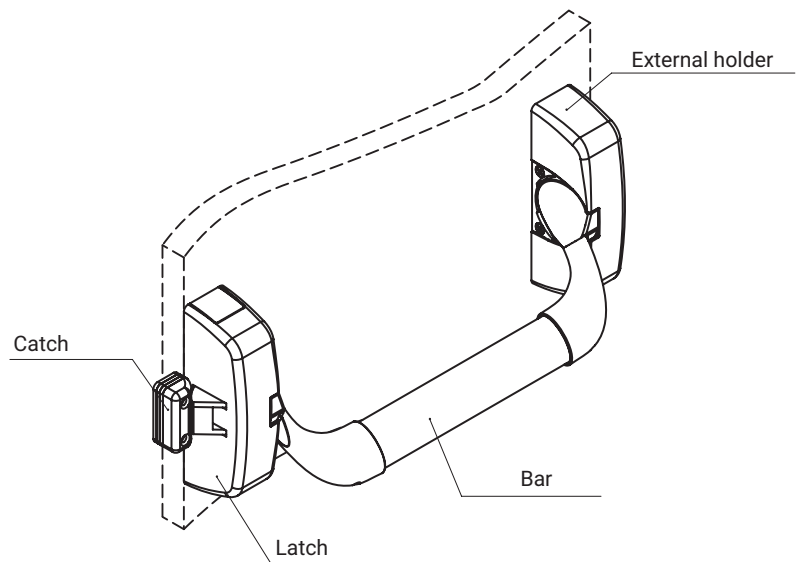
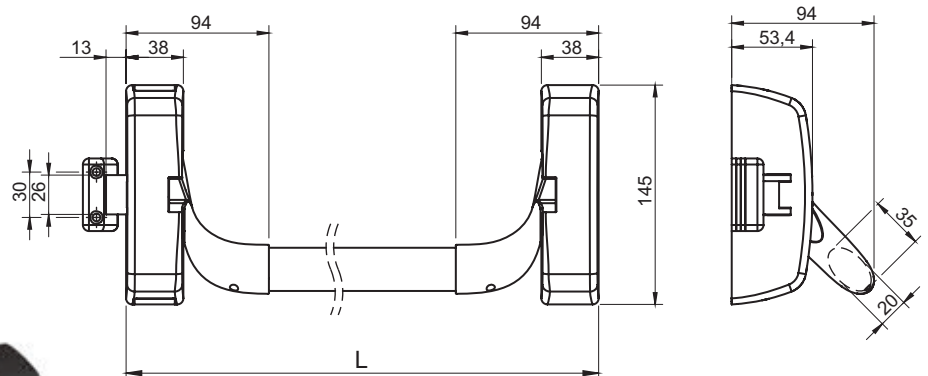

- The set includes::
- horizontal latch
 - external holder,
 - horizontal bar (state size L at order)
 - catch with a set of spacers

- Accessories to be ordered separately:
- external holder 1B.ZA.100,

Housings of lock and external holder, horizontal bar are made of ZAMAK
internal lock mechanism - galvanized steel ; bar, catch - powder-coated steel

CATALOGUE NUMBER	COMPONENTS	FINISH [C]		
		RAL 9005	RAL 7035	RAL 3020
1B.ZA.001	Horizontal latch			
	External holder	04	05	-
	Catch			
	Horizontal bar	04	05	12

How to order:

Catalogue number

Finish for a horizontal latch, external holder and a catch

Closure width

Finish for a horizontal bar

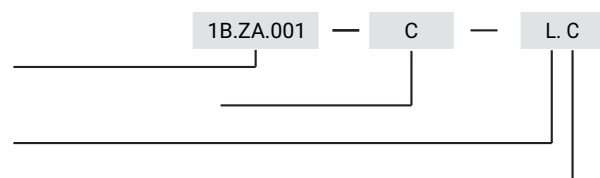

Anti-panic lock DOUBLE-POINT VERTICAL LATCH (top / bottom)

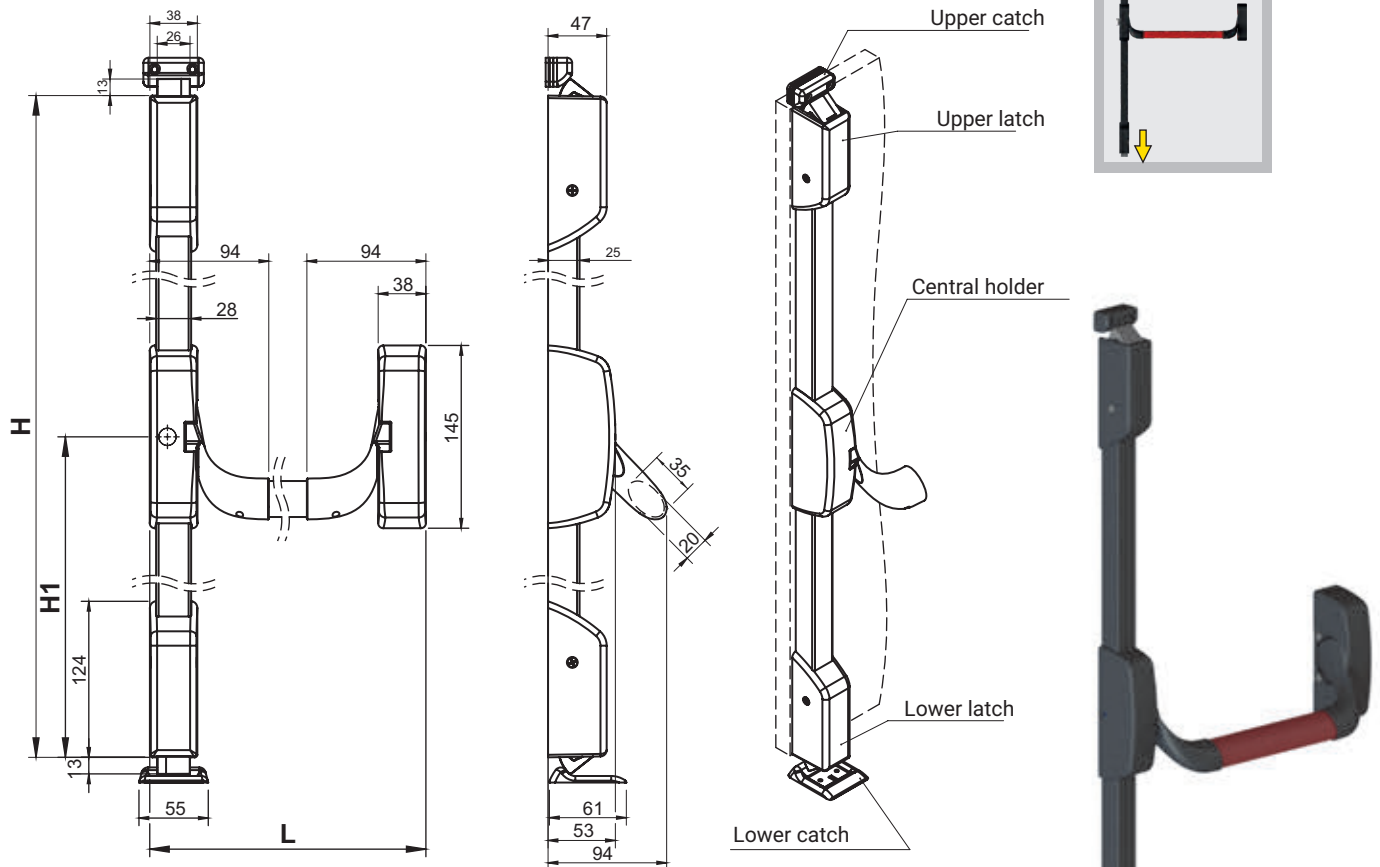

- The set includes::
- central holder,
 - vertical upper latch,
 - vertical lower latch,
 - horizontal bar (state size L at order),
 - upper and lower rod (state dimension of H and H1 at order),
 - upper catch with a set of spacers,
 - lower catch,

- Accessories to be ordered separately:
- external holder 1B.ZA.100,

Housings of locks and catches, horizontal bar are made of ZAMAK;
internal lock mechanism, rod - galvanized steel; bar, catch - powder-coated steel

CATALOGUE NUMBER	COMPONENTS	FINISH [C]		
		RAL 9005	RAL 7035	RAL 3020
1B.ZA.002	Central holder			
	Vertical latch	04	05	-
	Catch			
	Horizontal bar	04	05	12

How to order:

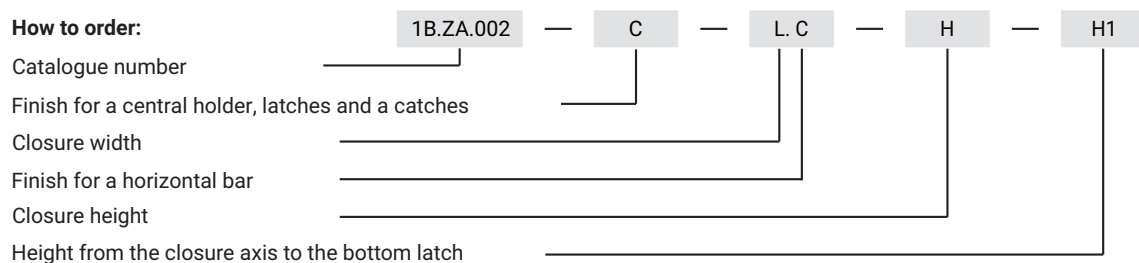



Anti-panic lock DOUBLE-POINT VERTICAL LATCH (top / bottom)

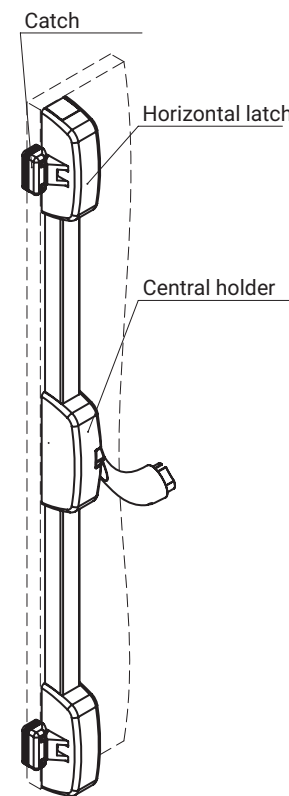
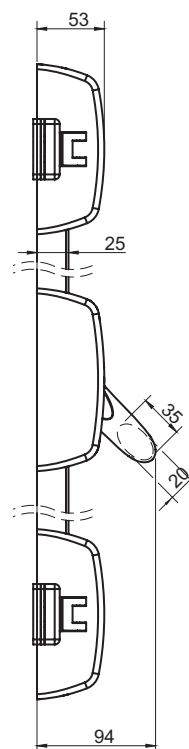
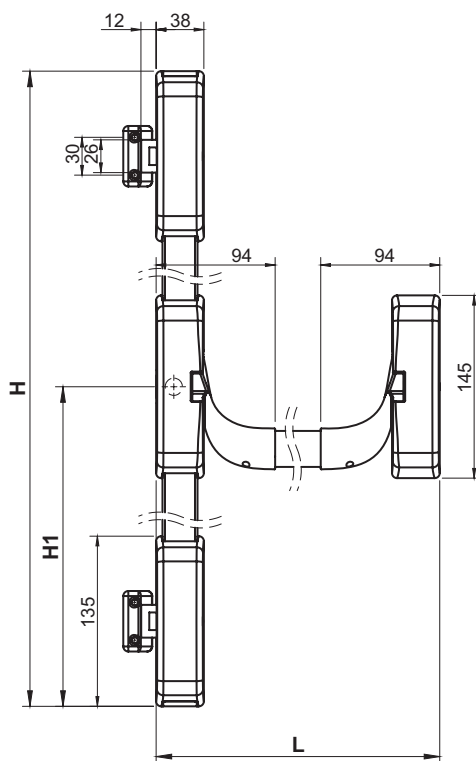

- The set includes:
- central holder,
 - horizontal latch (x2),
 - horizontal bar (state size L at order),
 - upper and lower rod (state dimension of H and H1 at order),
 - upper catch with a set of spacers (x2),

Accessories to be ordered separately:

- external holder 1B.ZA.100

Housings of locks and catches, horizontal bar are made of ZAMAK;
internal lock mechanism, rod - galvanized steel; bar, catch - powder-coated steel

CATALOGUE NUMBER	COMPONENTS	FINISH [C]		
		RAL 9005	RAL 7035	RAL 3020
1B.ZA.003	Central holder			
	Vertical latch	04	05	-
	Catch			
	Horizontal bar	04	05	12

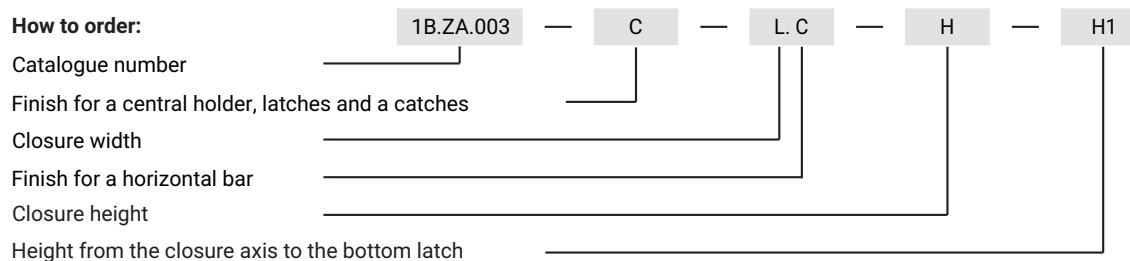

Anti-panic lock DOUBLE-POINT VERTICAL AND HORIZONTAL LATCH (top / side)

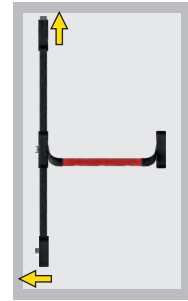
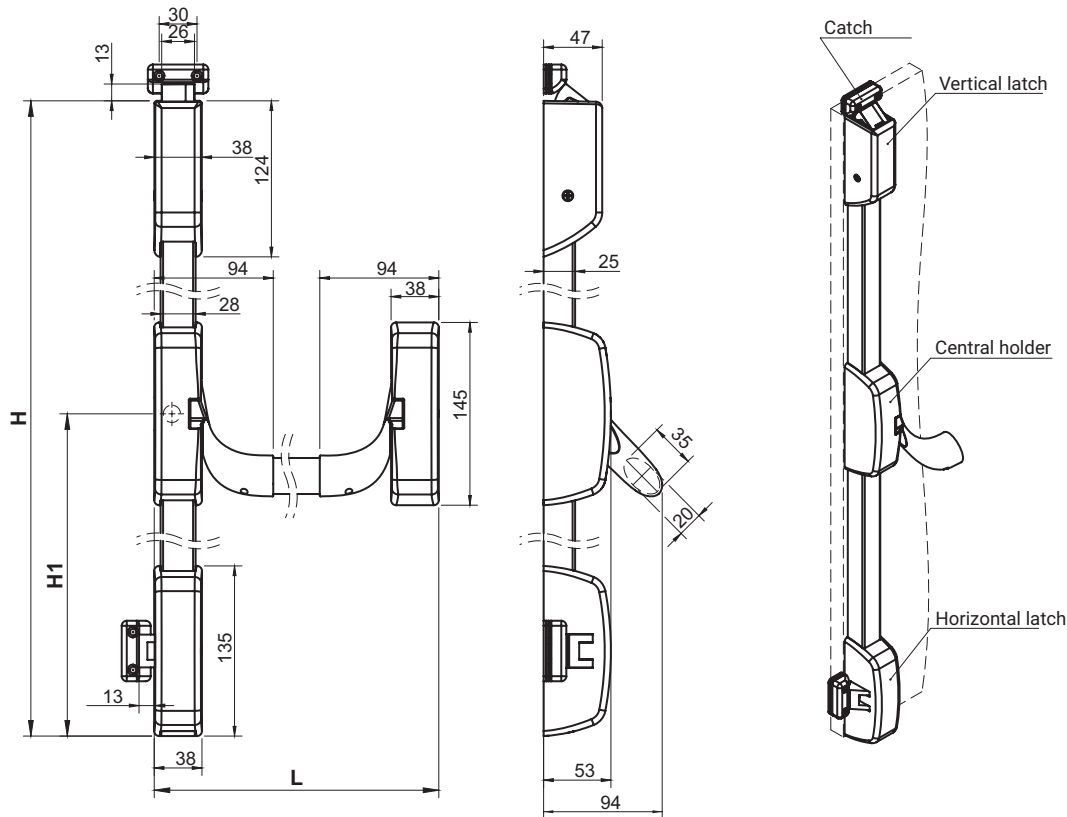

- The set includes:
- central holder,
 - vertical latch,
 - horizontal latch,
 - horizontal bar (state size L at order),
 - upper and lower rod (state dimension of H and H1 at order),
 - catch with a set of spacers (x2)

- Accessories to be ordered separately:
- external holder 1B.ZA.100

Housings of locks and catches, horizontal bar are made of ZAMAK;
internal lock mechanism, rod - galvanized steel; bar, catch - powder-coated steel

CATALOGUE NUMBER	COMPONENTS	FINISH [C]		
		RAL 9005	RAL 7035	RAL 3020
1B.ZA.004	Central holder			
	Latch	04	05	-
	Catch			
	Horizontal bar	04	05	12

How to order:

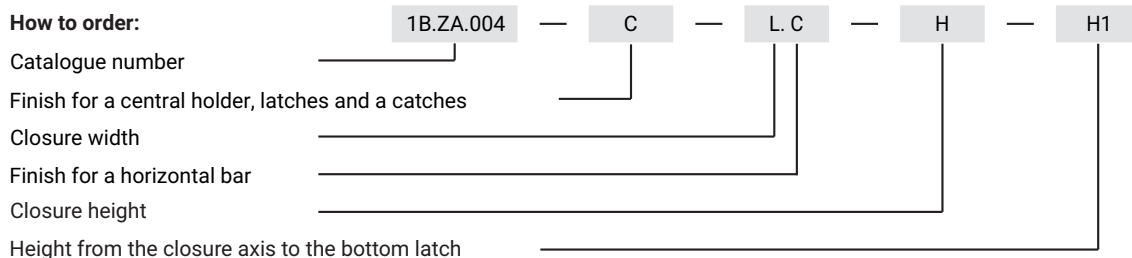

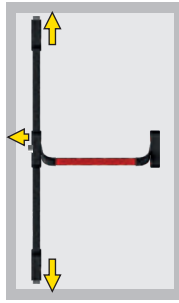

Anti-panic lock THREE-POINT LATCH (side / top / bottom)

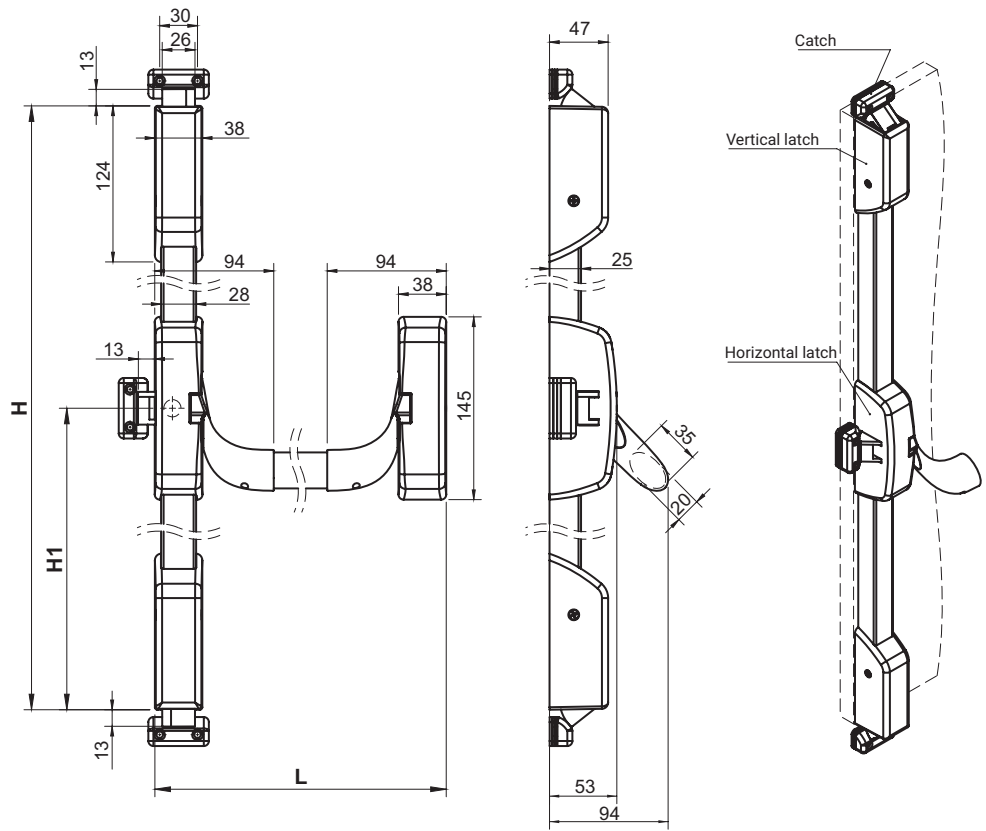

- The set includes:
- central holder,
 - vertical latch (x2),
 - horizontal latch,
 - horizontal bar (state size L at order),
 - upper and lower rod (state dimension of H and H1 at order),
 - catch with a set of spacers (x3)

Accessories to be ordered separately:

- external holder 1B.ZA.100

Housings of locks and catches, horizontal bar are made of ZAMAK;
internal lock mechanism, rod - galvanized steel; bar, catch - powder-coated steel

CATALOGUE NUMBER	COMPONENTS	FINISH [C]		
		RAL 9005	RAL 7035	RAL 3020
1B.ZA.005	Central holder			
	Latch	04	05	-
	Catch			
	Horizontal bar	04	05	12

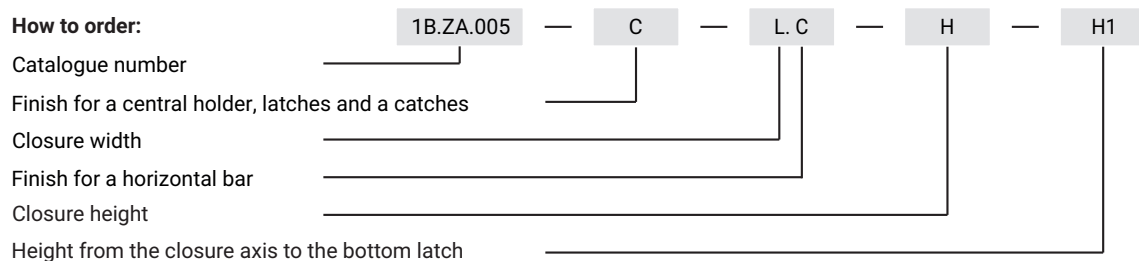

Anti-panic lock THREE-POINT LATCH (side / side / side)

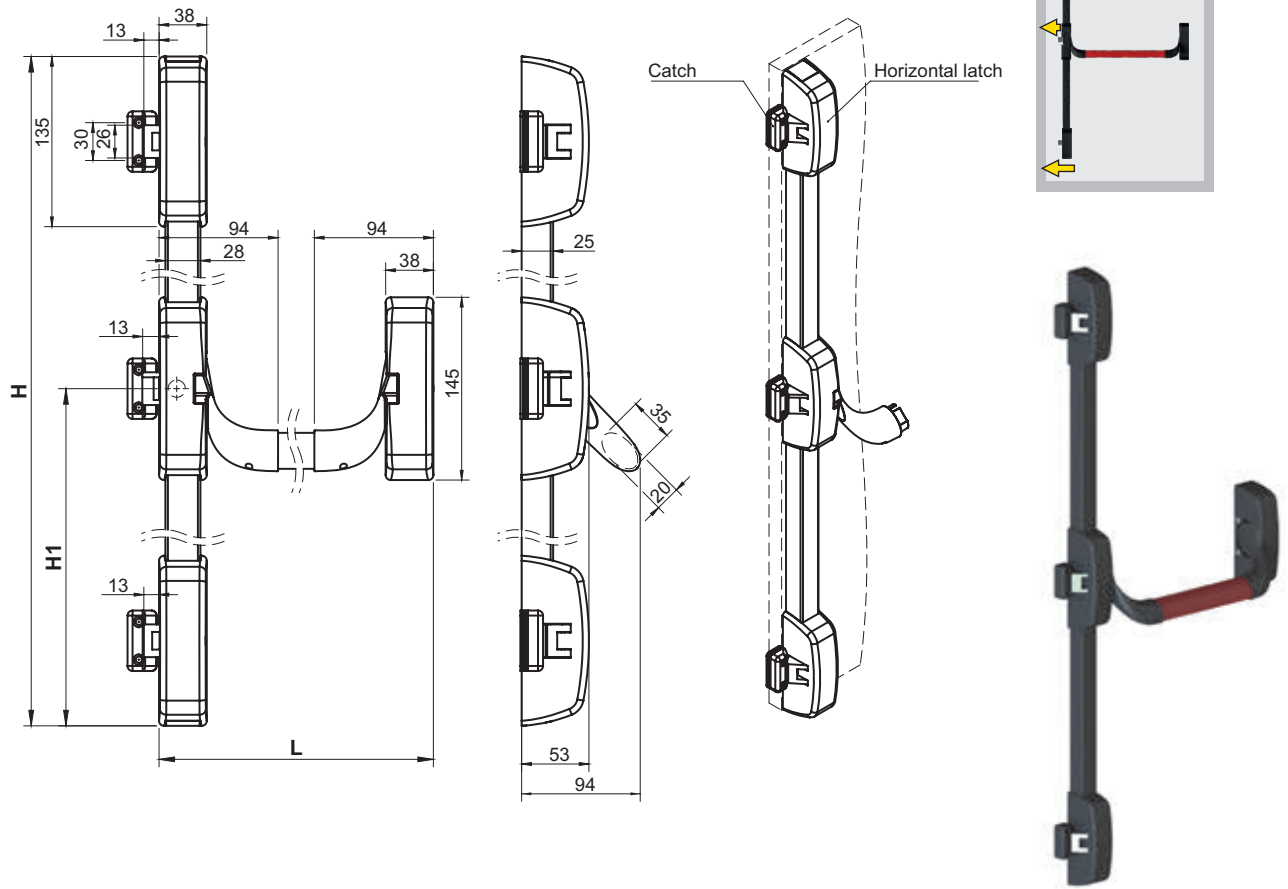

- The set includes:
- central holder,
 - horizontal latch (x3),
 - horizontal bar (state size L at order),
 - upper and lower rod (state dimension of H and H1 at order),
 - catch with a set of spacers (x3)

- Accessories to be ordered separately:
- external holder 1B.ZA.100

Housings of locks and catches, horizontal bar are made of ZAMAK;
internal lock mechanism, rod - galvanized steel; bar, catch - powder-coated steel

CATALOGUE NUMBER	COMPONENTS	FINISH [C]		
		RAL 9005	RAL 7035	RAL 3020
1B.ZA.006	Central holder			
	Latch	04	05	-
	Catch			
	Horizontal bar	04	05	12

How to order:

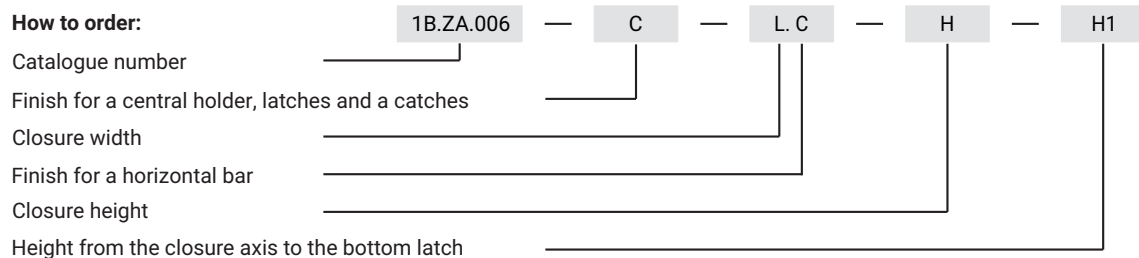

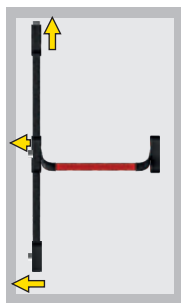

Anti-panic lock THREE-POINT LATCH (side / top / side)

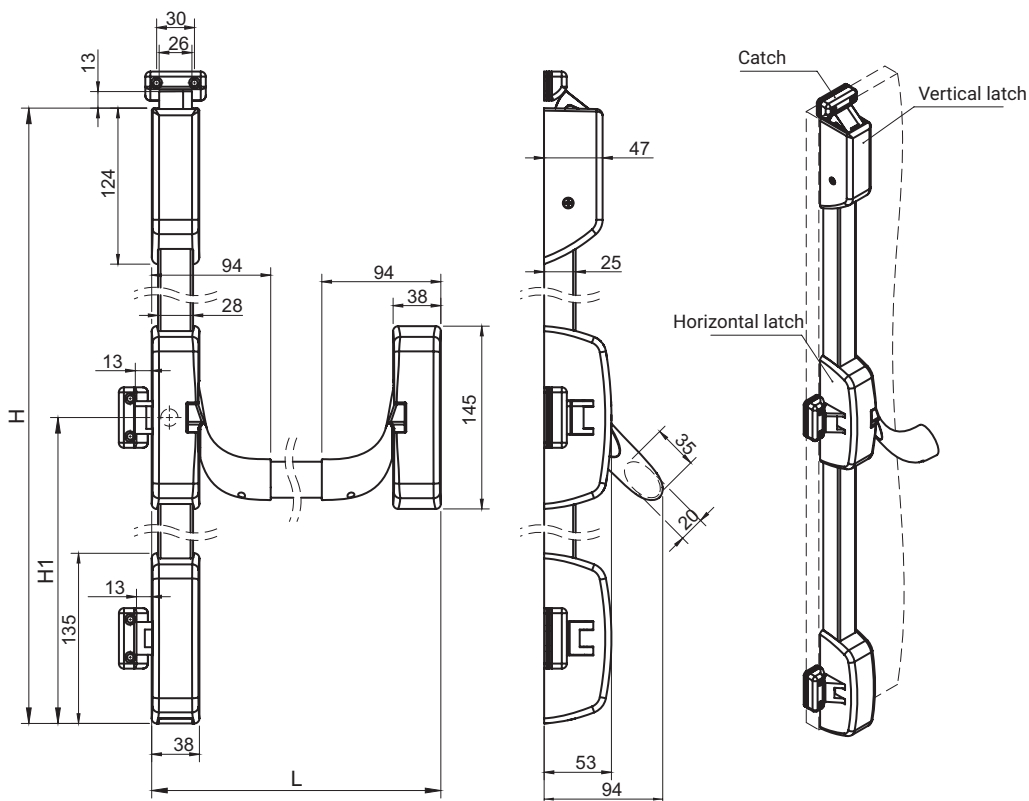

- The set includes:
- central holder,
 - horizontal latch (x2),
 - vertical latch
 - horizontal bar (state size L at order),
 - upper and lower rod (state dimension of H and H1 at order),
 - catch with a set of spacers (x3)

Accessories to be ordered separately:

- external holder 1B.ZA.100

Housings of locks and catches, horizontal bar are made of ZAMAK;

CATALOGUE NUMBER	COMPONENTS	FINISH [C]		
		RAL 9005	RAL 7035	RAL 3020
1B.ZA.007	Central holder			
	Latch	04	05	-
	Catch			
	Horizontal bar	04	05	12

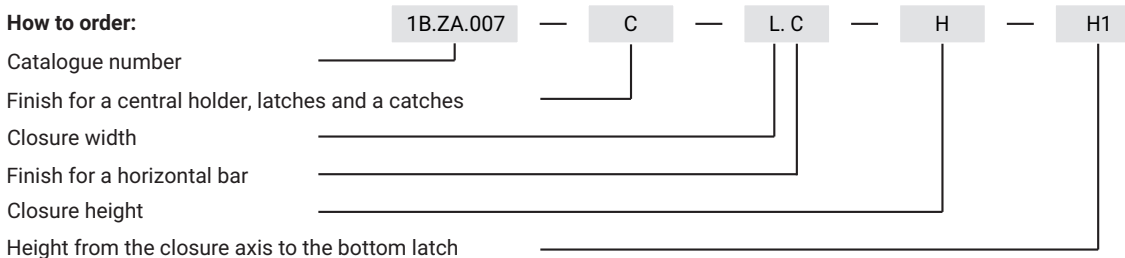



		1B.ZW.101	1B.ZW.102	1B.ZW.103	1B.ZW.104
1B.ZA.001 str. 1A-13		A1			
1B.ZA.002 str. 1A-14		A2	A1 A2	A1	A1
1B.ZA.003 str. 1A-15				A2	
1B.ZA.006 str. 1A-18					A2

How to order :

Cat.number for anti-panic lock for double wing door

Cat.number for anti-panic lock for first wing door

Cat.number for anti-panic lock for second wing door

where:

A1, A2 has a full number from the catalogue of chosen lock
(for locks 1B.ZA.001 without H and H1 dimensions)

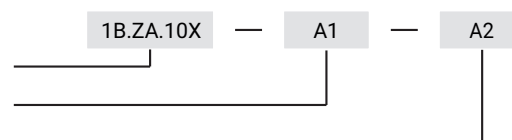

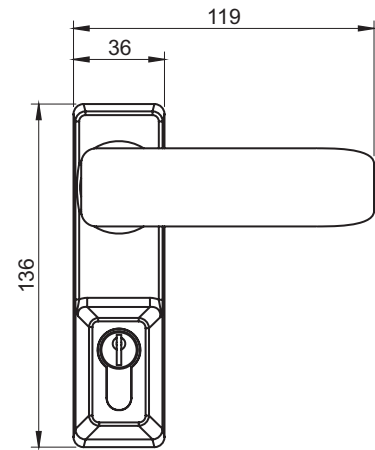
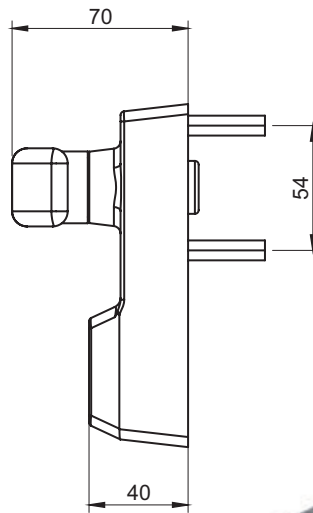

External fitting with handle for anti-panic locks. Provided with Europrofile insert.

CATALOGUE NUMBER	COMPONENTS	MATERIAL	FINISH [C]
			RAL 9005
1B.ZA.201	Klamka Obudowa	ZAMAK	04

How to order :

Catalogue number

Finish

1B.ZA.201 — C

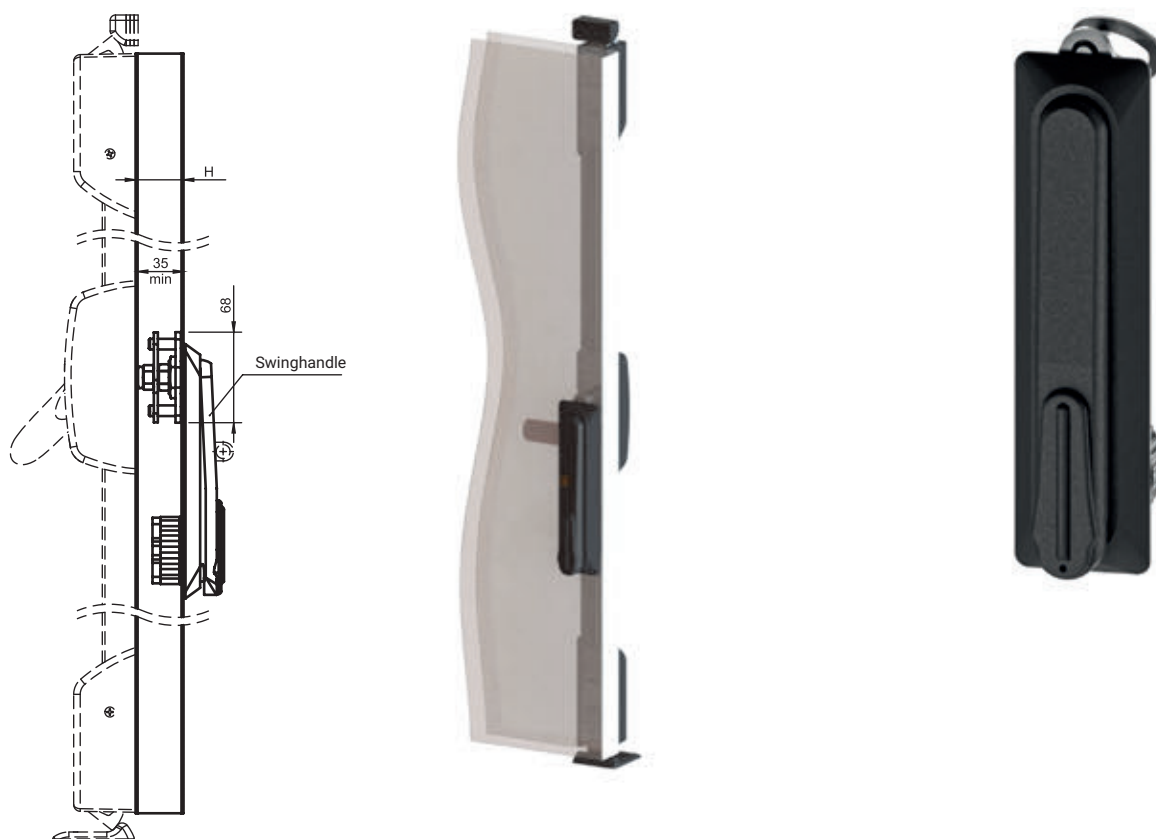

Mounting holes of locks with swinghandle according to catalogue pages of RS200 locks - page 1B-3, RS130 - page 1B-8. The ZA end piece in the catalogue number of swinghandles means that it is a lock adapted to cooperation with an anti-panic lock.

RS130/U ZA i RS200/U ZA - swinghandles with padlock protection.

SWINGHANDLES COMPATIBLE WITH ANTI-PANIC LOCKS				
TYPE OF LOCK	HANDLE MATERIAL, LOCK FINISH [C]			
	ZAMAK		Polyamide	
	RAL 9005	RAL 7035	RAL 9005	RAL 7035
RS130ZA RS130/UZA	04	-	07	-
RS200ZA RS200/UZA	04	05	07	08

How to order :

Catalogue number

Handle material, lock finish

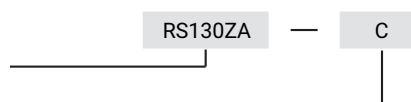

2 or 3 point locking

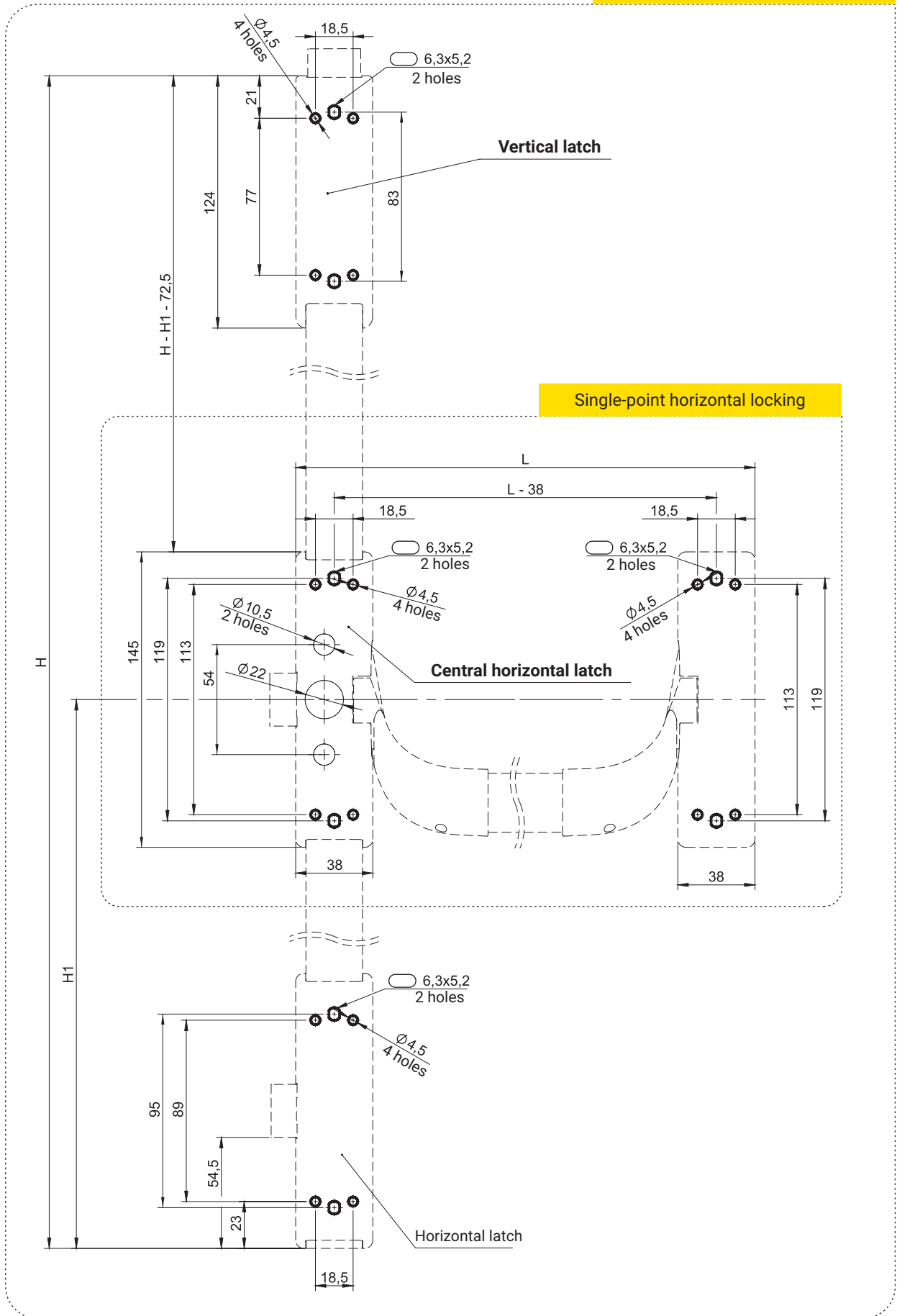

Each lock can be mounted on 4 holes $\varnothing 4,5$ or 2 holes 6,3x5,2



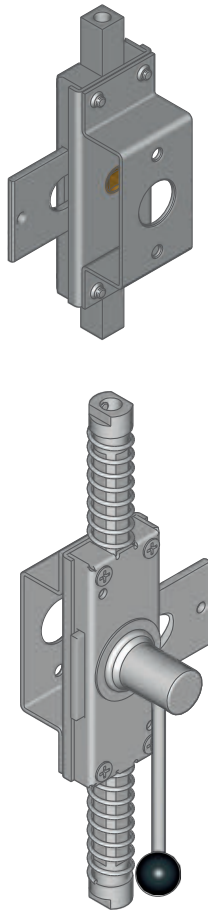

ZWM8 (with thread M8) **ZWM10** (with thread M10)

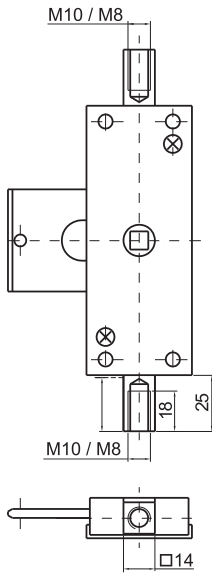

NOTE:

1. When ordering swinghandles RS100, RS130, RS140, RS110 RS210, RS200 for **internal lock** you should add letters ZW.
2. When ordering swinghandle RS100, RS200, RS130, RS140 RS110, RS210, for **intednal lock panik**, you should add letters ZWP.
3. Lock support only on special request.
4. Left or Right version only for **internal lock panik**

ZWM8 (with hole $\phi 8$)

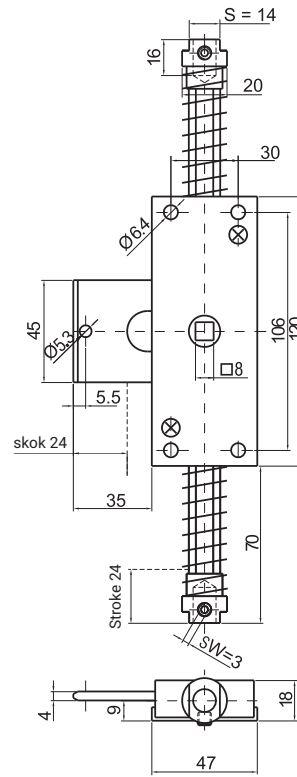

ZWM10 (with hole $\phi 10$)

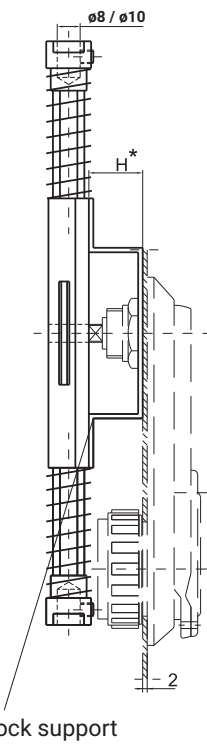

Lock support

ZWPM8 (with thread M8) **ZWPM10** (with thread M10)

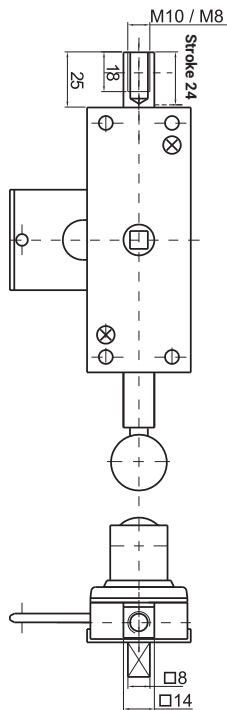

ZWPM8 (with hole $\phi 8$)

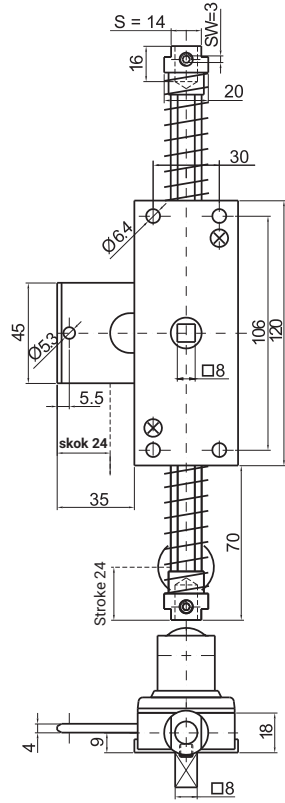

ZWPM10 (with hole $\phi 10$)

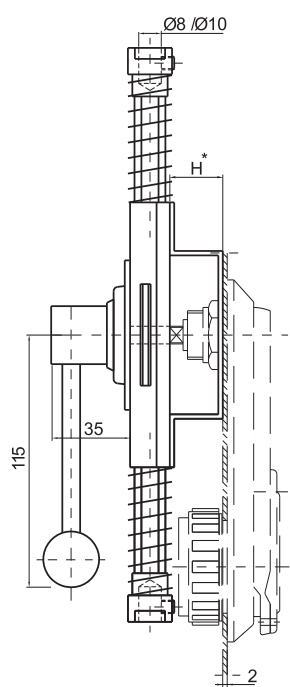

NOTE:

1. When ordering lock ZWP you must define H dimension and version: left or right

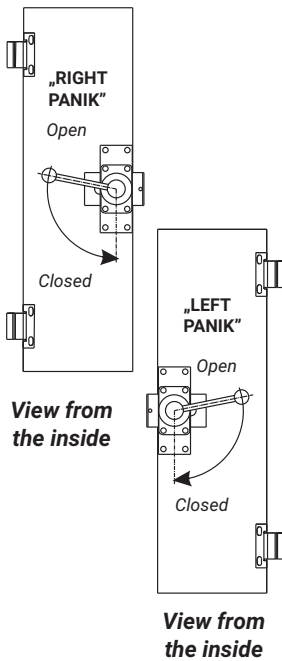

NAME	MATERIAL	NAME	MATERIAL
Internal lock ZWM8	Steel zinc plated	Internal lock panik ZWPM8	Steel zinc plated
Internal lock ZWM10		Internal lock ZWPM10	
Internal lock ZW8		Internal lock ZWP8	
Internal lock ZW10		Internal lock ZWP10	

• When ordering you must define H dimension

ZWPM8.002
(with thread M8)

ZWPM10.002
(with thread M10)

ZWP8.002
(with hole $\phi 8$)

ZWP10.002
(with hole $\phi 10$)

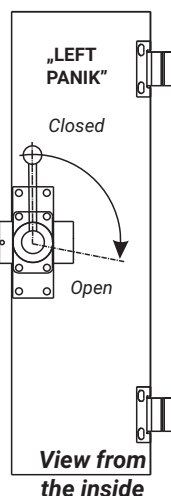
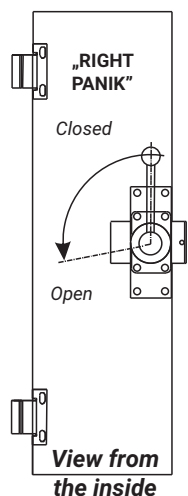
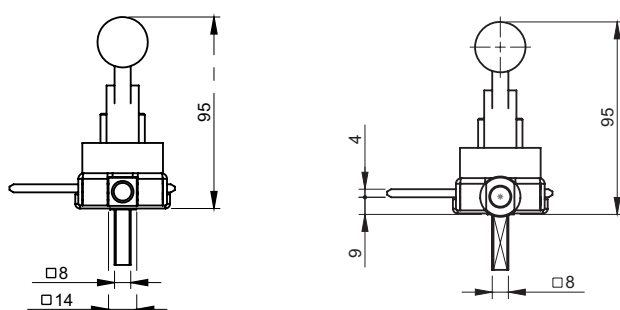
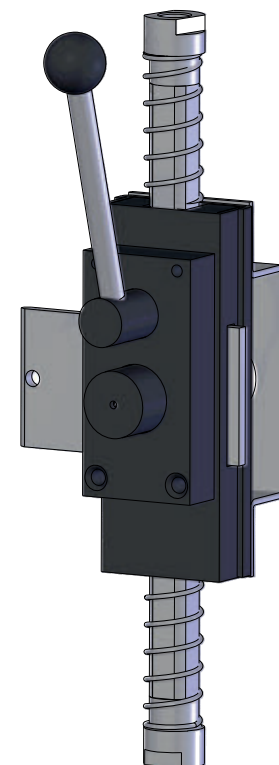
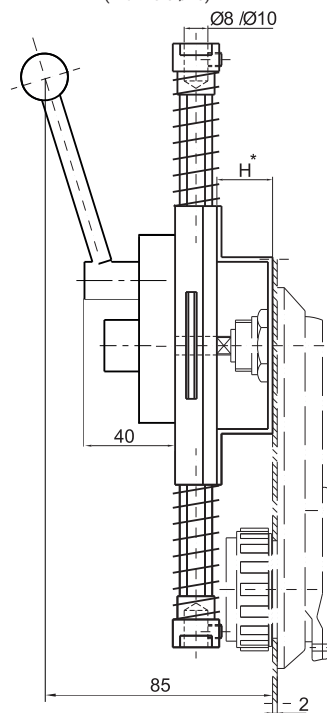
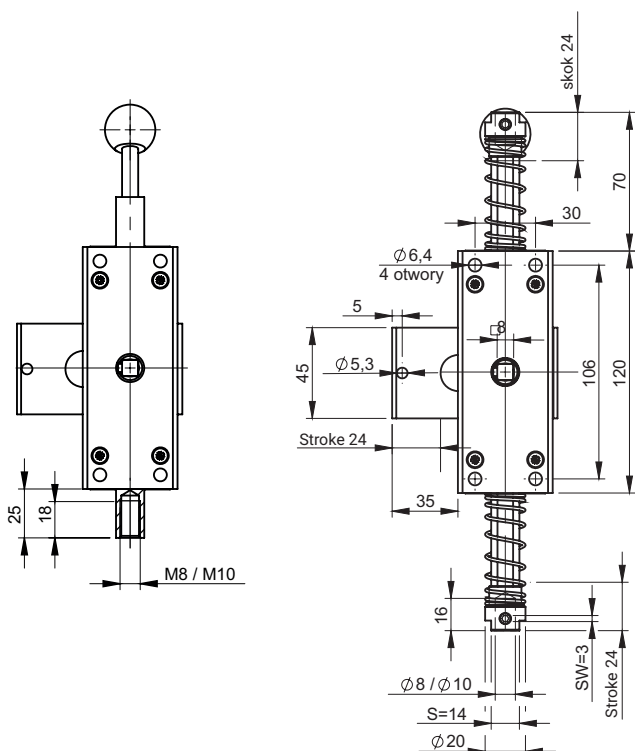

NOTE:
1. When ordering lock ZWP, you must define H dimension and version: left or right

NAME	MATERIAL
Internal lock panik ZWPM8.002	Steel zinc plated
Internal lock panik ZWPM10.002	
Internal lock panik ZWP8.002	
Internal lock panik ZWP10.002	
• When ordering you must define H dimension	

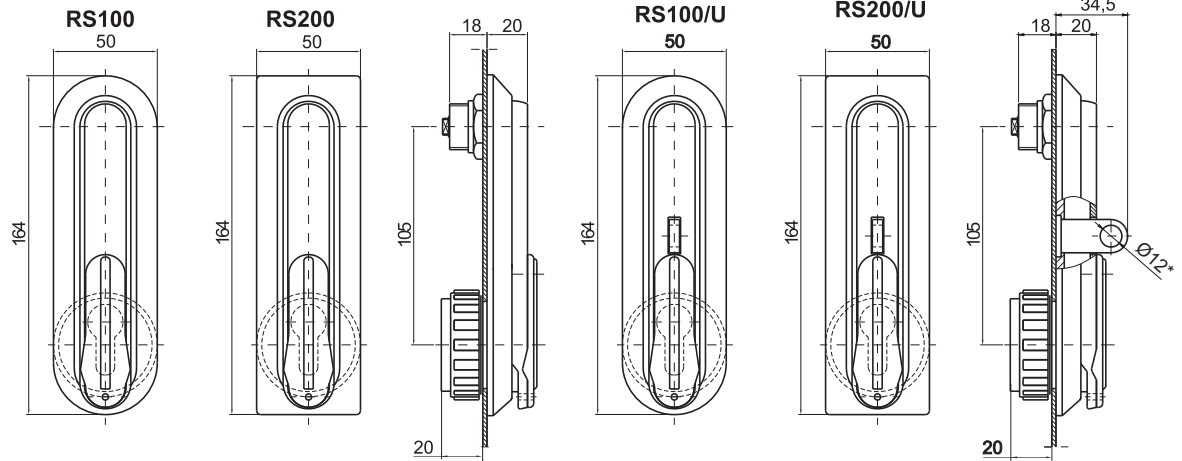

NOTE:

1. When ordering swinghandle RS100, RS200 for **internal lock**, you should add letters e.g. (RS100ZW, RS200ZW).
2. When ordering swinghandle RS100, RS200, for **internal lock panik**, you should add letters ZWP e.g. (RS100ZWP, RS200ZWP)

(*) - Padlock device is available with diameter Ø12

LOCK TYPE	COMPONENTS	MATERIAL	
RS100	Housing	Polyamide PA6	
RS200			
RS100/U	Housing Padlock device	Polyamide PA6	
RS200/U		ZAMAK5	
Material and finish [C]			
ZAMAK5		POLYAMIDE PA6	
RAL 9005	RAL 7035	RAL 9005	RAL 7035
04	05	07	08

How to order :



• Additionally there is a possibility of putting company logo a dust cover

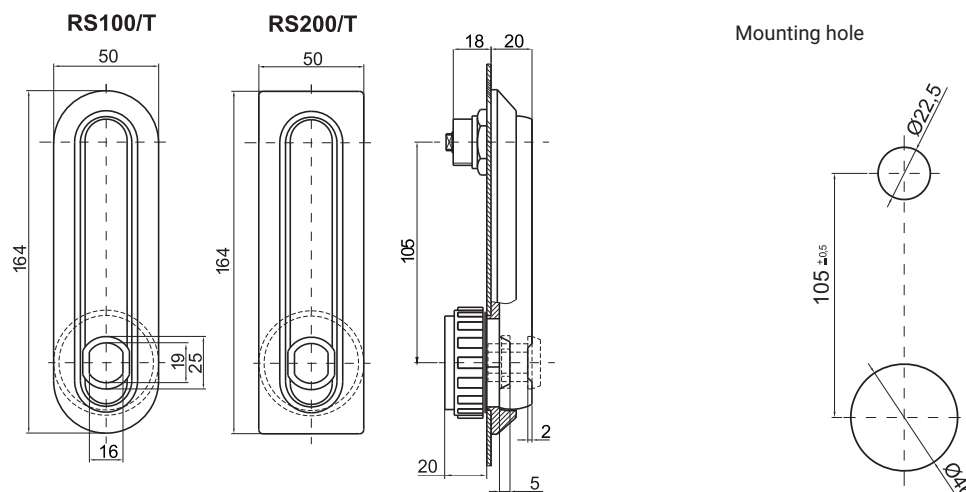

LOCK TYPE	COMPONENTS	MATERIAL	FINISH [C]	
			RAL 9005	RAL 7035
RS100/T	Housing, Handle	Polyamide PA6	07	08
RS200/T				

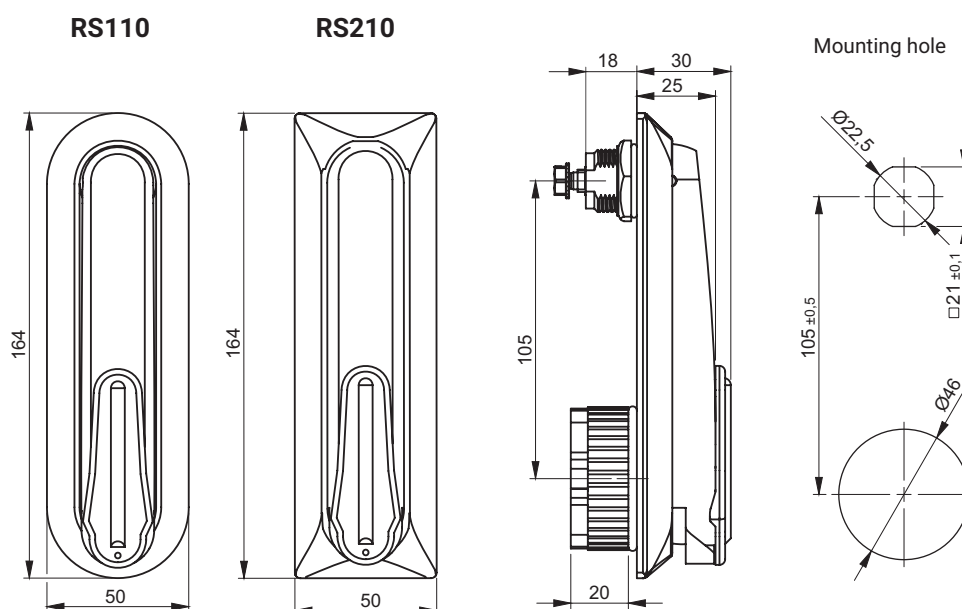

DETAIL	COMPONENTS	MATERIAL	FINISH [C]	
			RAL 9005	RAL 7035
RS110 RS210	Housing, Handle	Polyamide PA GF30	07	08

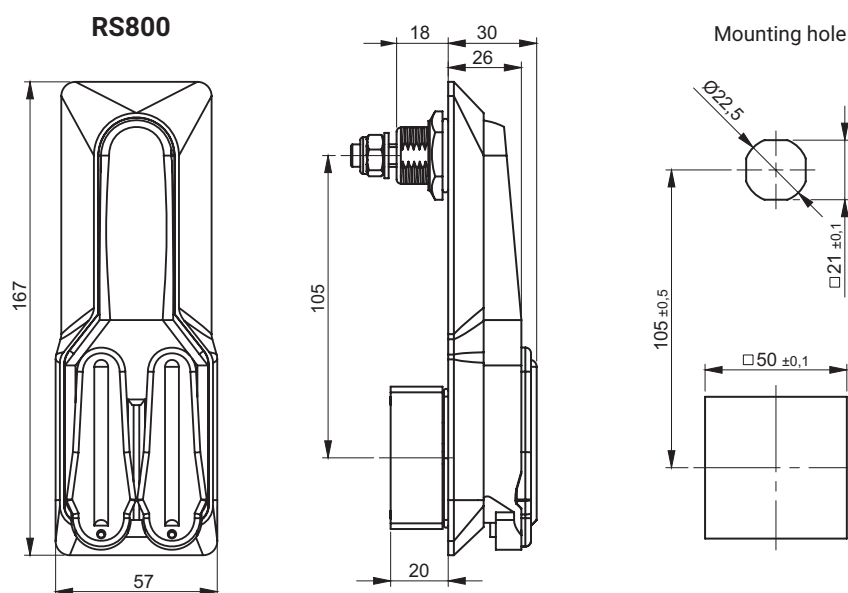

DETAIL	COMPONENTS	MATERIAL	FINISH [C]	
			RAL 9005	RAL 7035
RS800 RS800W	Housing, Handle	Polyamide PA GF30	07	08

NOTE:
Locking is the enhanced version or without reinforcement.
RS800W - with steel reinforcement handle.

How to order:

Catalogue number

Finish

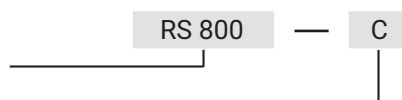

Swinghandle

RS400, RS400W, RS400/U, RS400W/U, RS420, RS420/U, RS500, RS500W, RS500/U, RS500W/U, RS 520, RS520/U



ROZTOCZE

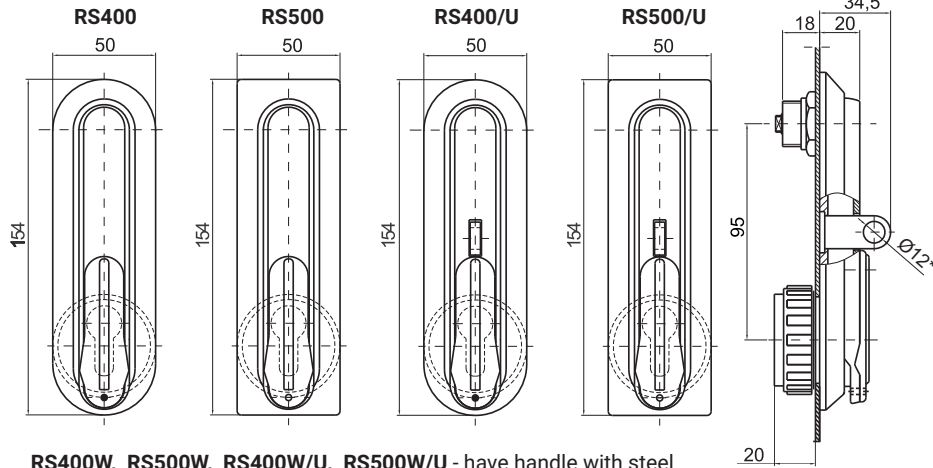

RS400W, RS500W, RS400W/U, RS500W/U - have handle with steel strengthening inside

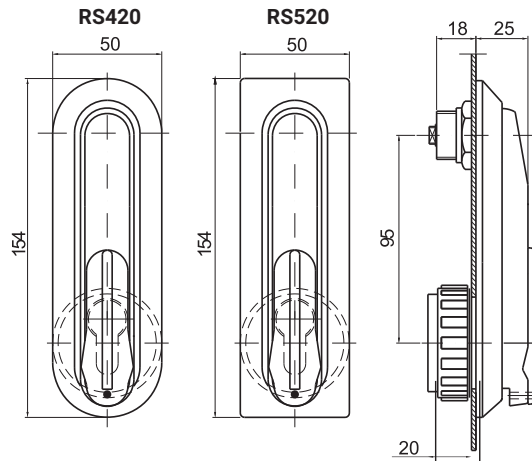
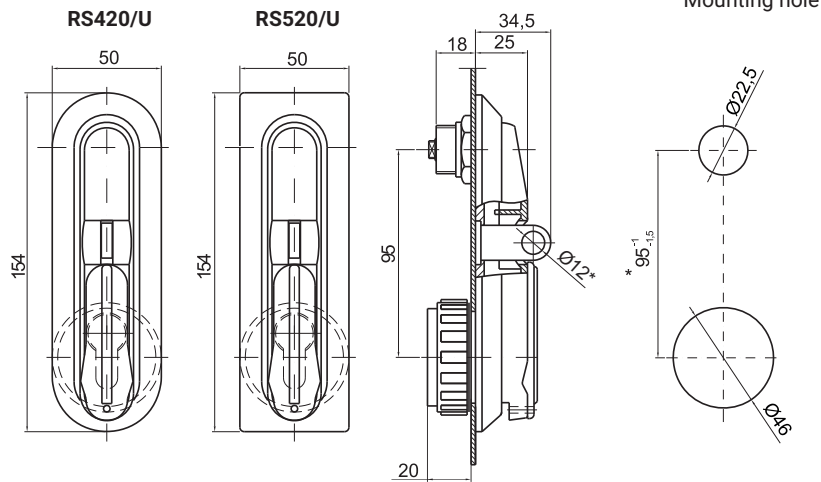

(*) - Padlock device is available with diameter Ø12

NAME		COMPONENTS	MATERIAL	FINISH [C]	
				RAL 9005	RAL 7035
RS400	RS500	Housing, handle	Polyamide PA6	07	08
RS400W	RS500W				
RS400/U	RS500/U				
RS400W/U	RS500W/U				
RS420	RS520				
RS420/U	RS520/U				

• Additionally there is a possibility of putting company logo on a dust cover

How to order:

Catalogue number RS420/U — C
 Finish _____

| Swinghandles

www.roztocze.eu

Swinghandle RS430, RS430/U, RS530, RS530/U



ROZTOCZE

1B

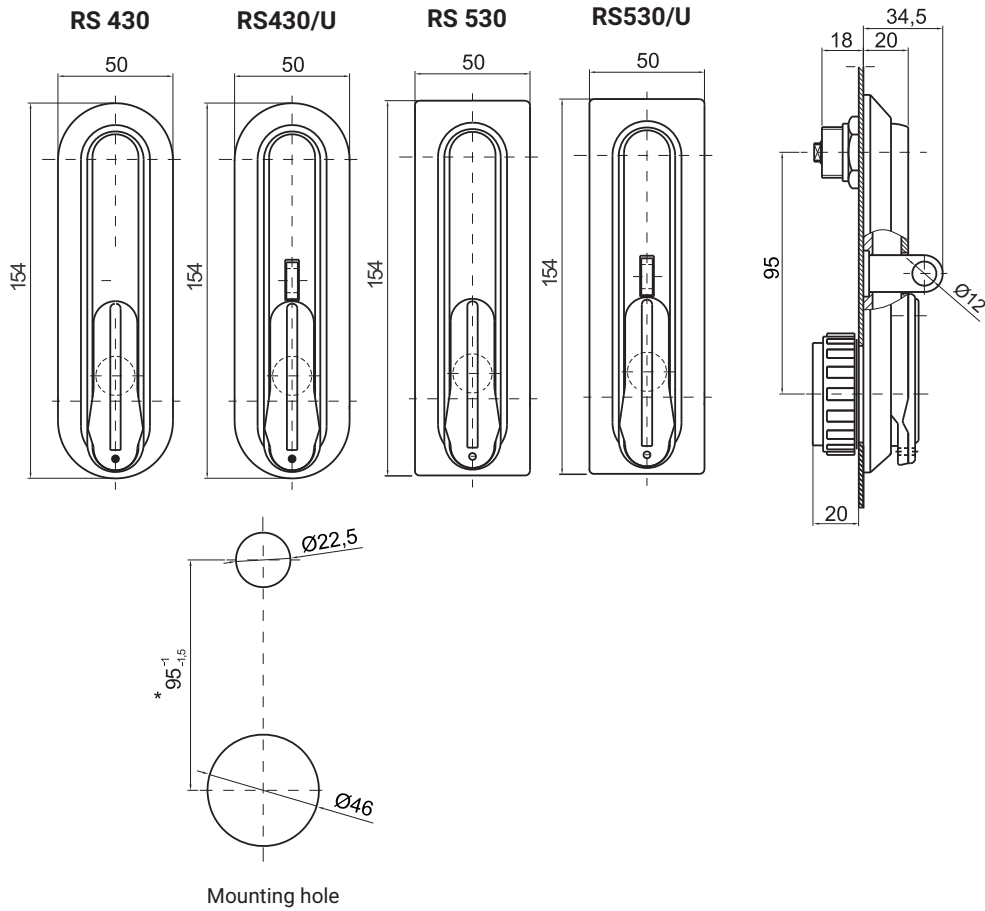

LOCK TYPE	COMPONENTS	MATERIAL						
RS 430, RS 430/U RS 530, RS 530/U	Housing, handle	Poliamide						
	Padlock ring	ZAMAK						
Inserts		FINISH [C]						
D3	D5	T9	T10	KW 8	S	N	RAL 9005 07	RAL 7035 08

How to order : RS430/U — T9 — C

Type of lock _____
 Type of insert _____
 Finish _____

LOCK TYPE	COMPONENTS	MATERIAL		
RS 430, RS 430/U RS 530, RS 530/U	Housing, handle	Poliamid		
	Padlock ring	ZAMAK		
Key code		FINISH [C]		
1333	455E	2342E	RAL 9005	RAL 7035
405E	1242E	Different code	07	08

How to order : RS430/U 1333 C

Type of lock _____
 Key code _____
 Finish _____

Lock with handle RS 430, RS 430/U, RS 530, RS 530/U is compatible with cam: 15, 16, 19, 21, 35, 36, JK-10018, JK1-10018, JK2-10018, J-6000
 H.G dimension to be chosen from pages 1C-10 to 1C-17





Mounting hole

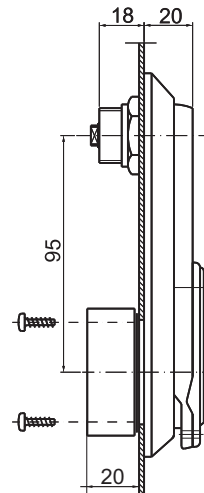
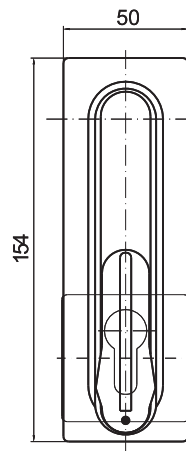
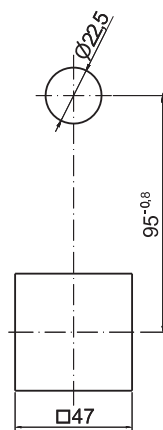

LOCK TYPE	COMPONENTS	MATERIAL	FINISH [C]	
			RAL 9005	RAL 7035
RS510	Housing, handle	Polyamide - PA6	07	08

• Additionally there is a possibility of putting company logo on a dust cover

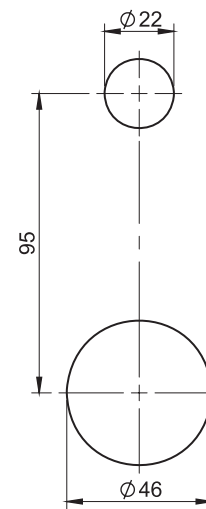
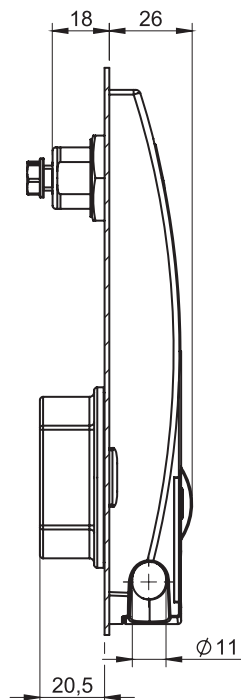
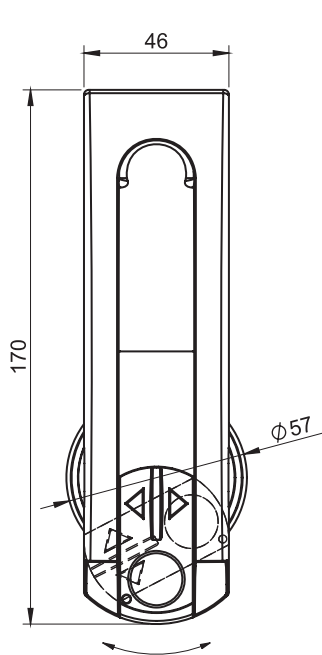

Mounting hole

Przesłona wkładki obracana

LOCK TYPE	COMPONENTS	MATERIAL	FINISH [C]	
			RAL 9005	RAL 7035
RS900	Housing, handle	Polyamide - PA6	07	08

How to order :

Type of lock
Finish

RS900

C

Swinghandle RS130, RS135, RS140, RS145

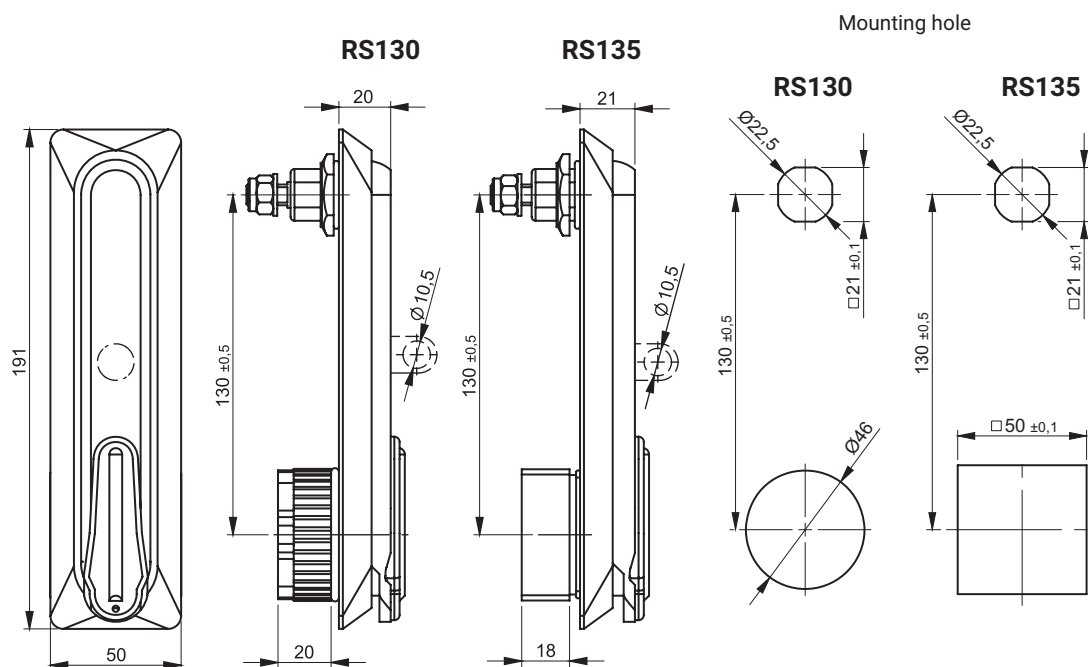

LOCK TYPE	COMPONENTS	MATERIAL
RS130, RS130/U	Housing	Polyamide - PA6 GF30
RS135, RS135/U		
Material and finish [C]		
ZAMAK	Polyamide PA6 GF30	
RAL9005	RAL9005	
04	07	

How to order : **RS130** — **C**
 Type of lock —
 Material handle, colour —

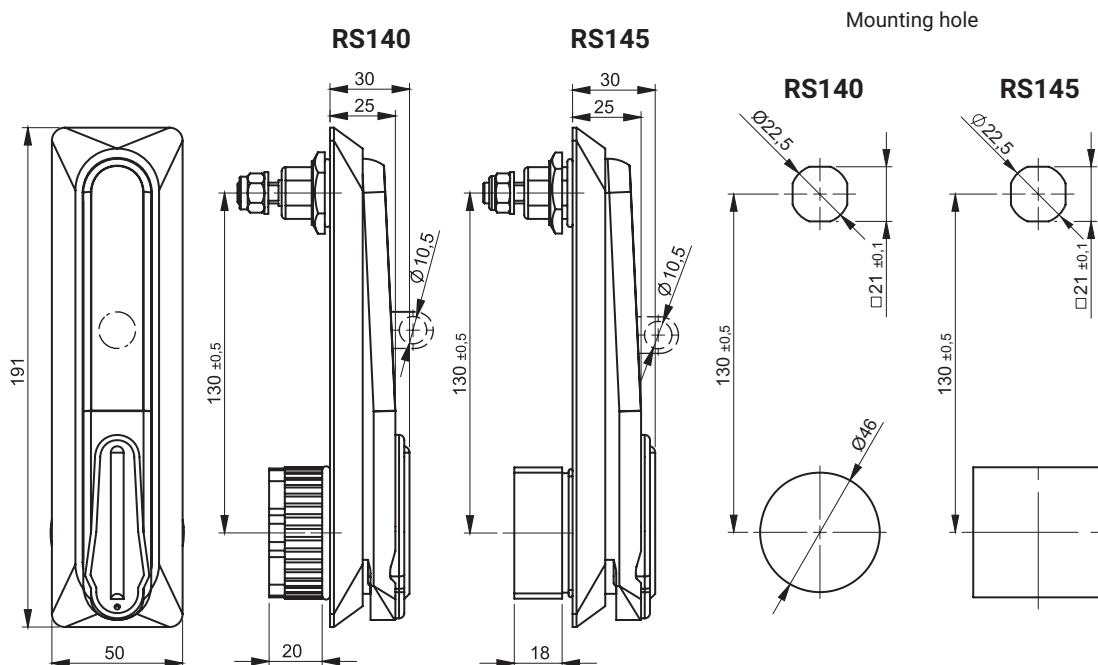

LOCK TYPE	COMPONENTS	MATERIAL	FINISH [C]
			RAL 9005
RS140, RS140/U	Housing	Polyamide PA6 GF30	04
RS145, RS145/U	Handle	ZAMAK5	



It has two opening points:

- Mechanical - cylinder with a patent key for emergency opening in case of power failure
- Electronic - built-in micro servo

Technical data:

- RFID technology
- 4-digit PIN code
- Compatible with the access control system EMI-One
- Built-in handle position sensor in the lock for warning purposes the user to leave the lock open when the cabinet door is closed.
- Power supply for 12V DC lock
- Built-in buzzer for lock action signaling
- LED indicating the lock status
- Storage of login information Minimum 10 years

- The RS-E.001.M lock cooperates with the cogwel mechanism MZ2 (pp. 1C-30 to 1C-31)
- The RS-E.001.N lock cooperates with the 1C.902.001 cover plate.(pages 1C-27) and with cams 1-point from group 11, 13



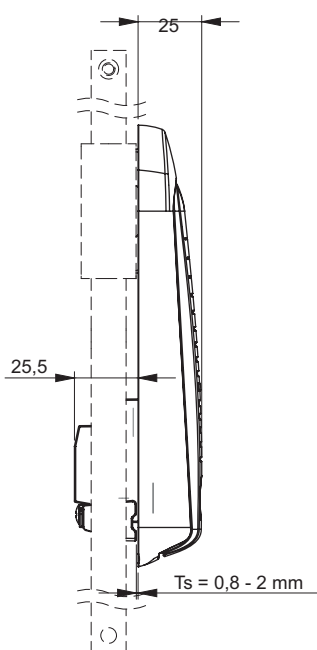
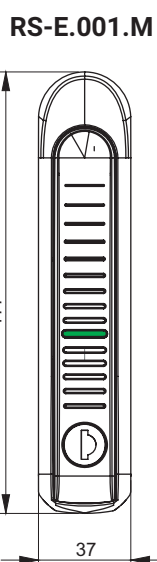
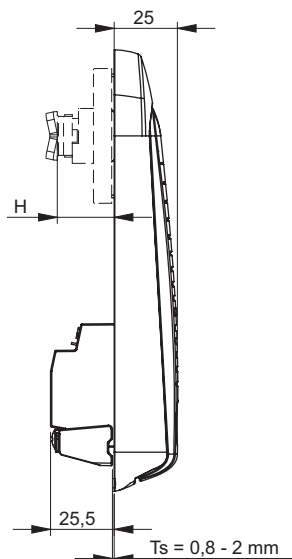
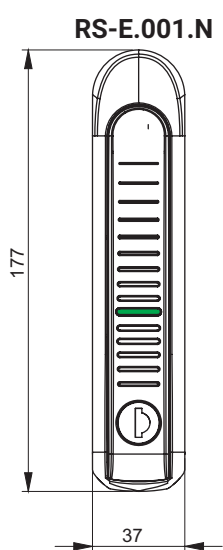

Mounting hole

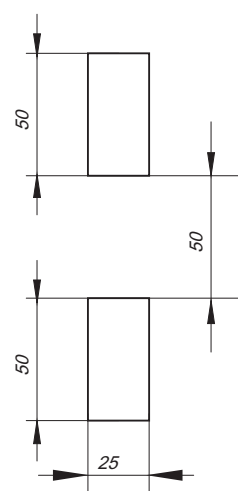

Power supply : 12V DC.

Lock RS-E.001MZ is compatible with cogwheel mechanism MZ2 (pg 1C-30 to 1C-31) - should be ordered separately.

Lock RS-E.001N is compatible with a cap 1C.902.001 (pg 1C-27)

and cams: 1-point from group 11, 13 (pg 1C-10, 1C-11) - should be ordered separately.

* EMI access control equipment to be ordered separately

CATALOGUE NUMBER	COMPONENTS	MATERIAL	FINISH [C]
			RAL 9005
RS-E.001.N RS-E.001.M	Handle, housing	PA6 GF30	07
CONFIGURATIONS OF ACCESS ARE POSSIBLE			
DESCRIPTION			CONFIGURATIONS
key	Standard lock		001
key + RFID card	Stand-alone version with RFID system		002
key + keypad	Stand-alone version with keypad lock		003
key + EMI	Electronic lock with EMI* control system		004
key + RFID card + EMI	Electronic lock with EMI* control system		005

How to order : RS-E.001.N — 002 — [C]
 Type of lock _____
 Configurations of access _____
 Finish _____

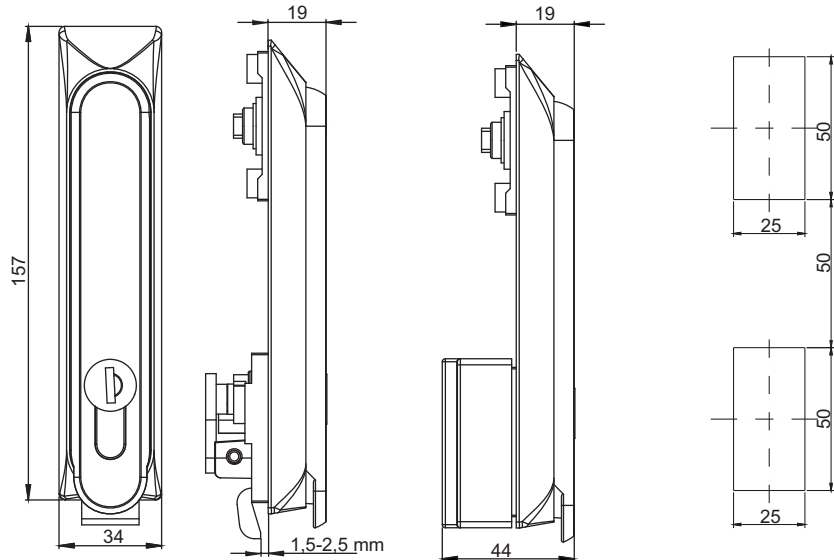

Lock type A

Lock type B

Mounting hole



With cursor



With ear



Standard version

Type lock A	Standard	Pin shaped	—	RS650.001
		Cylinder	—	RS650.002
		Cylinder insert	—	RS650.003
	Ear	Pin shaped	—	RS650.004
		Cylinder	—	RS650.005
		Cylinder insert	—	RS650.006
	Cursor	Pin shaped	—	RS650.007
		Cylinder	—	RS650.008
		Cylinder insert	—	RS650.009
Type lock B	Standard	Pin shaped	—	RS650.101
		Cylinder	—	RS650.102
		Cylinder insert	—	RS650.103
	Ear	Pin shaped	—	RS650.104
		Cylinder	—	RS650.105
		Cylinder insert	—	RS650.106
	Cursor	Pin shaped	—	RS650.107
		Cylinder	—	RS650.108
		Cylinder insert	—	RS650.109

TYPE OF LOCK						COMPONENTS							MATERIAL			
RS 650						Body, Handle							Polyamide PA6 GF30			
KEY CODE						FINISH [C]		PIN								
1333	405E	455E	1242E	2342E	RK	RAL 9005	RAL 7035									
						07	08	D3	D5	T9	T10	KW 8	S	N		

How to order:

Catalogue number

Type of lock

Finish

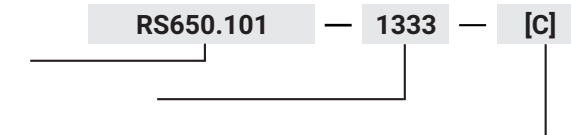

RS600

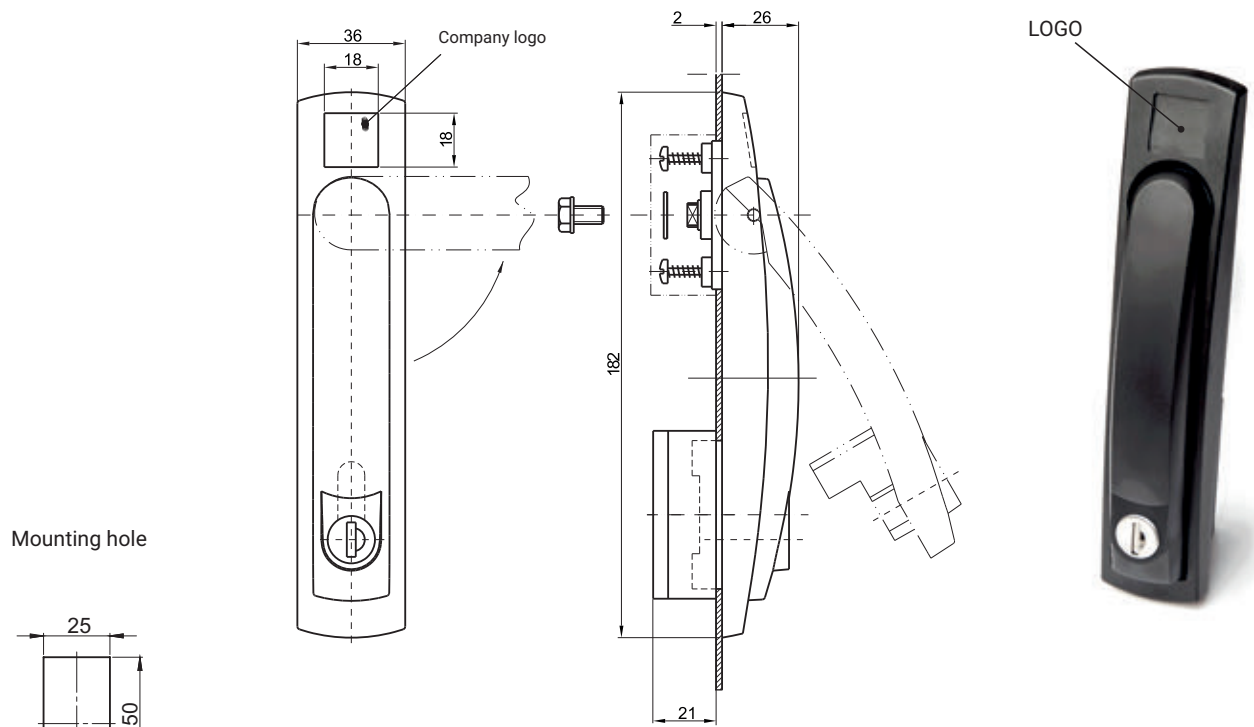

RS610.M RS610.N

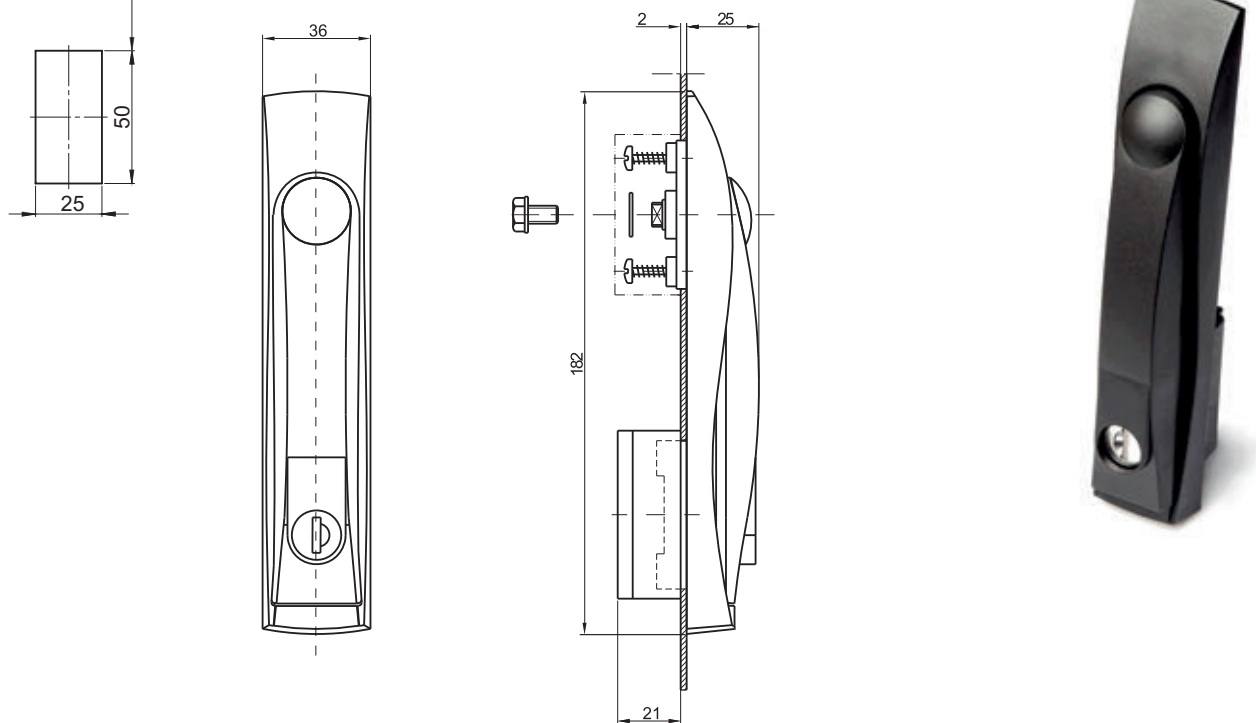

* possibility of making a logo by Pad Printing

			FINISH [C]
TYPE OF LOCK	COMPONENTS	MATERIAL	RAL 9005
RS600	Body, Handle	Polyamide PA6 GF30	07
RS610			

How to order:

Type of lock
Finish

RS610 — [C]

stainless steel

IP65

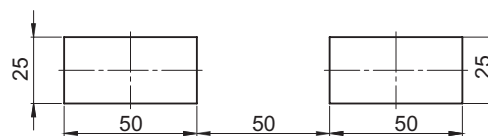
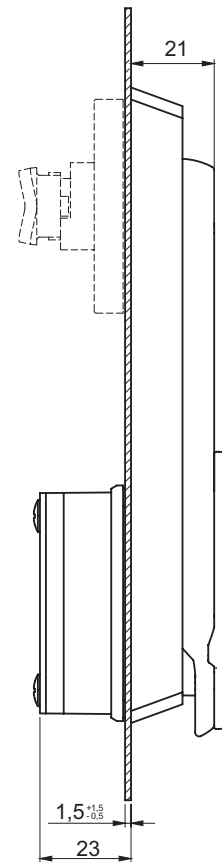
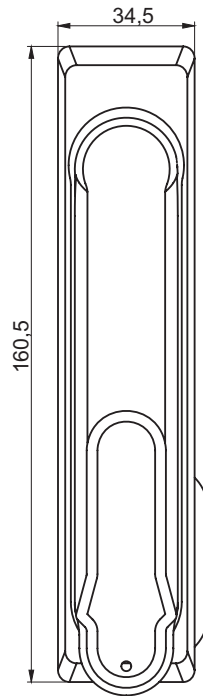

Mounting hole

Additional equipment for the MZ cogwheel mechanism
also for the N cap
should be ordered separately check page 1A-3, 1A-4

NAME	COMPONENTS	MATERIAL
RS173.002	Body, Handle	Stainless steel

How to order:

RS173.002 — SN

Type of lock
Finish



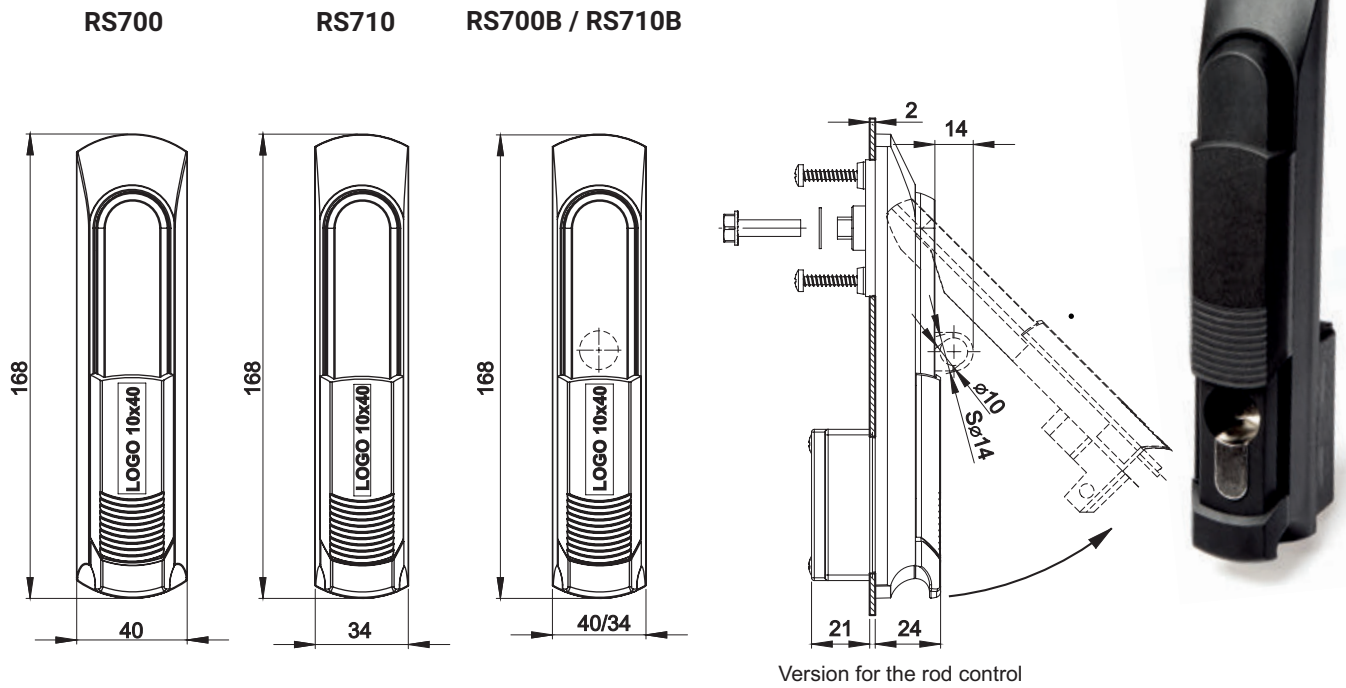

Version for the rod control

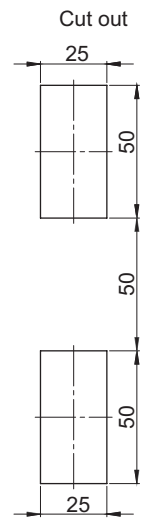

Material and colour [C]			
ZAMAK5		POLYAMIDE	
RAL 9005	RAL 7035	RAL 9005	RAL 7035
04	05	07	08
TYPE OF SWINGHANDLE	VERSION	COMPONENTS	MATERIAL
RS700.N	For the cap 1C.902.001	Housing, Sliding dust cover	Polyamide
RS710.N			
RS700B.N			
RS710B.N			
RS700.M	For the rod control		
RS710.M			
RS700B.M			
RS710B.M			

How to order : **RS700B.M** — **[C]**
 Type of lock _____
 Material handle, finish _____

The lock is fitted with profile which should be ordered separately (pg. 1C-1, 1C-2)
 The lock is fitted with gear mechanism (pg. 1C-30 to 1C-33)
 or the cover plate 1C.902.001 (pg.1C-27), should be ordered separately.
 Lock RS700-U, RS710-U - version with the pin for padlock.

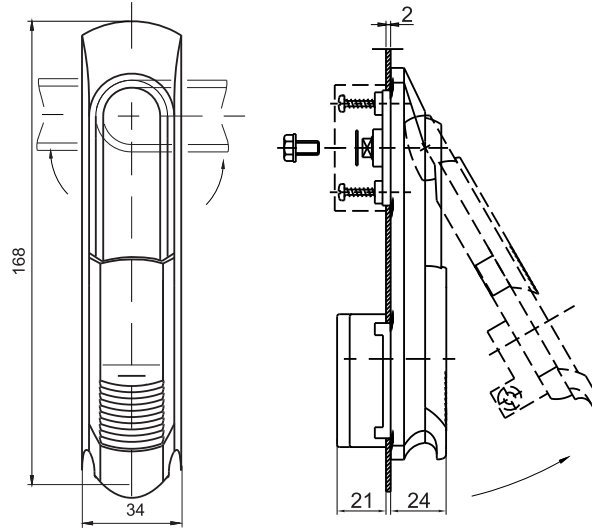

LOCK TYPE	VERSION	COMPONENTS	MATERIAL				
RS715.N	Cap 1C.902.001	Body, Handle	Polyamide				
RS715.M	Cogwheel mechanism MZ		Polyamide				
KEY CODE					FINISH [c]		
1333	405E	455E	1242E	2342E	RK	RAL 9005 07	RAL 7035 08

How to order :

Lock type
Key code
Finish

RS715.M — 1333 — [C]

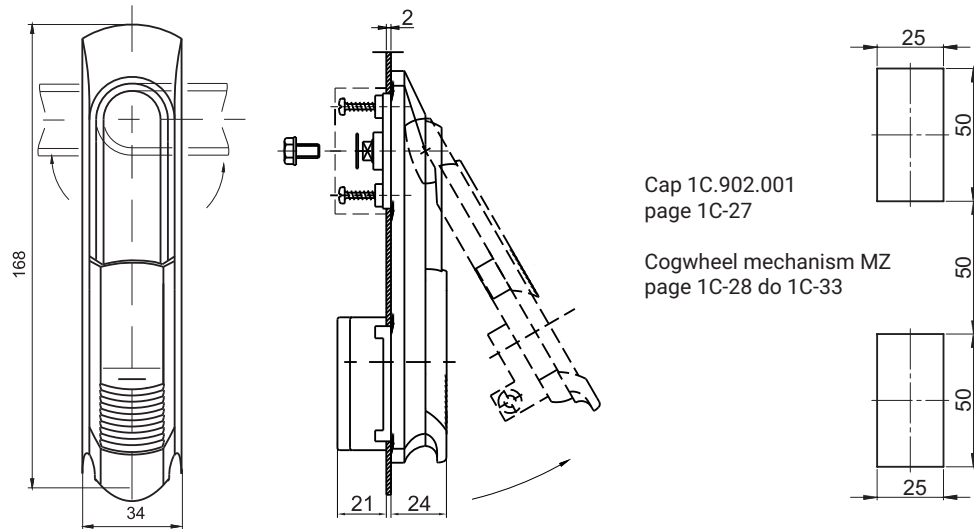

Cap 1C.902.001
page 1C-27

Cogwheel mechanism MZ
page 1C-28 do 1C-33

LOCK TYPE	VERSION	COMPONENTS	MATERIAL					
RS716.N	Cap 1C.902.001	Body, Handle	Polyamide					
RS716.M	Cogwheel mechanism MZ		Polyamide					
PIN					FINISH [c]			
							RAL 9005 07	RAL 7035 08

How to order :

Lock type
Pin type
Finish

RS716.N — T9 — [C]

*possibility to make company logo on handle

RS730-45

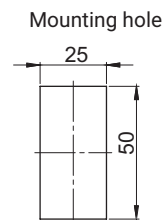
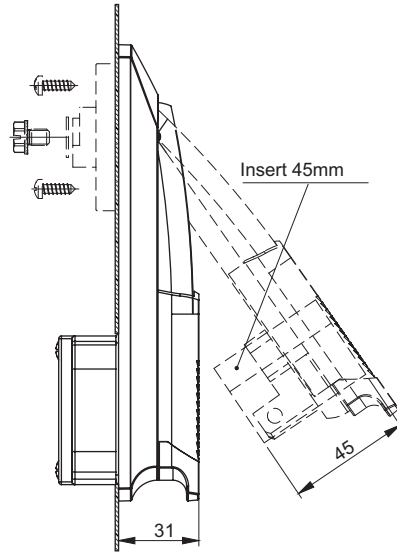
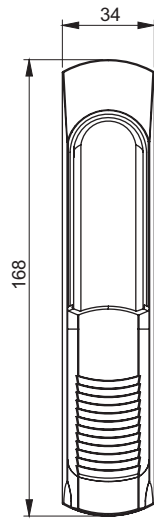

RS730-47

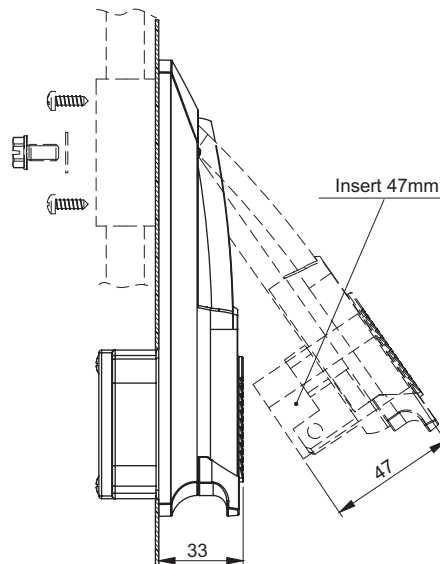
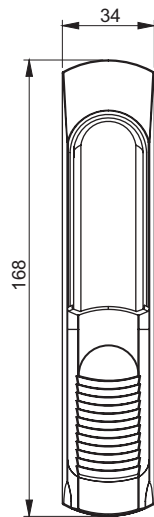

LOCK TYPE	VERSION	COMPONENTS	MATERIAL	FINISH [C]	
				RAL 9005	RAL 7035
RS730-45.N	For the cap 1C.902.001	Housing, Handle	Polyamide PA GF30	07	08
RS730-47.N					
RS730-45.M	For the rod control				
RS730-47.M					

How to order :

RS730-45.N — **[C]**

Lock type

Finish

The lock is fitted with profile which should be ordered separately (pg. 1C-1, 1C-2)

The lock is fitted with gear mechanism (pg. 1C-30 to 1C-33)

or the cover plate 1C.902.001 (pg.1C-27), should be ordered separately.

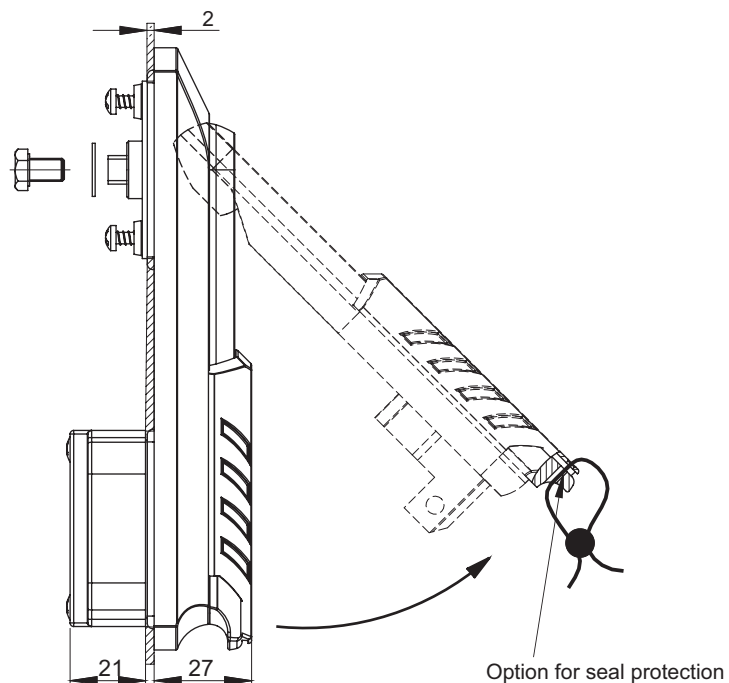
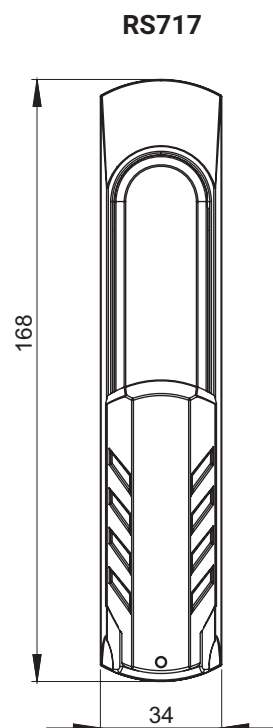

Cut out

TYPE OF LOCK	VERSION	COMPONENTS	MATERIAL	FINISH [C]	
				RAL 9005	RAL 7035
RS717.N	For the cap 1C.902.001	Housing	PA6 GF30	04	05
RS717.M	For the rod control	Handle, Slide	ZAMAK		

How to order : **RS717.M** — **[C]**
 Type of lock _____
 Finish _____

The lock is fitted with profile which should be ordered separately (pg. 1C-1, 1C-2)
 The lock is fitted with gear mechanism (pg. 1C-30 to 1C-33)
 or the cover plate 1C.902.001 (pg. 1C-27), should be ordered separately.
 Option for seal protection.

Swinghandle RS720, RW400/N, RW410/N, RW400/M, RW410/M

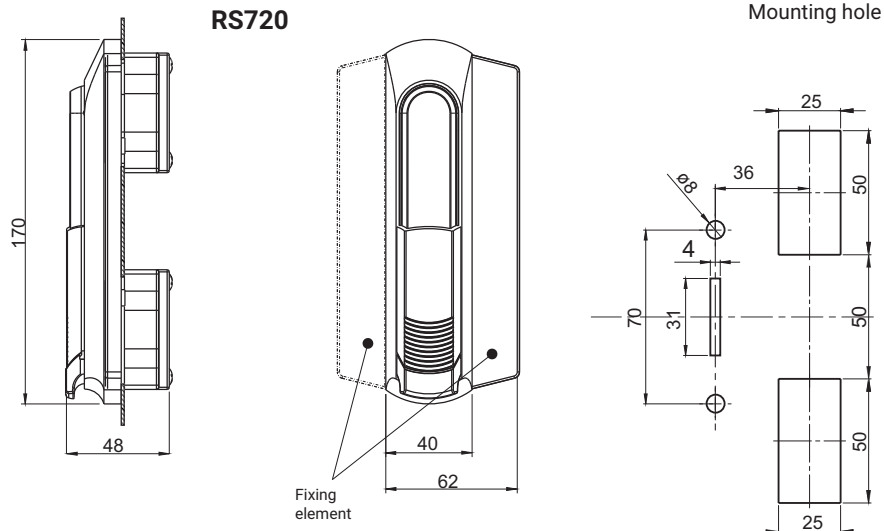

NOTE:
Fixing element can be fixed on left and right side of the lock

TYPE OF LOCK	COMPONENTS	MATERIAL	FINISH [C]
			RAL 9005
RS720.001	Body, Handle, Fixing element	Polyamide	07
RS720.002	Body, Fixing element	Polyamide	07
	Handle	ZAMAK	04

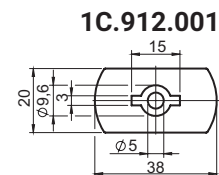
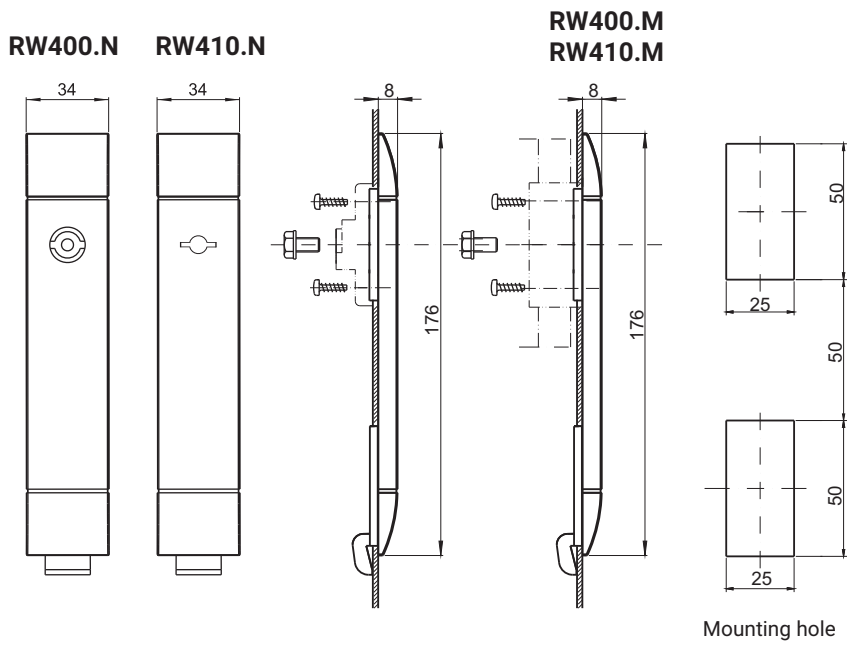

Protective cover compatible with locks: RW100, RW110, RW400

TYPE OF LOCK	COMPONENTS	MATERIAL	FINISH [C]
			RAL 9005
RW400.N, RW410.N RW400.M, RW410.M	Body	Polyamide	07
1C.912.001	Protective cover	Polyamide	07

How to order :
Type of lock **RW400.N** — **[C]**
Finish

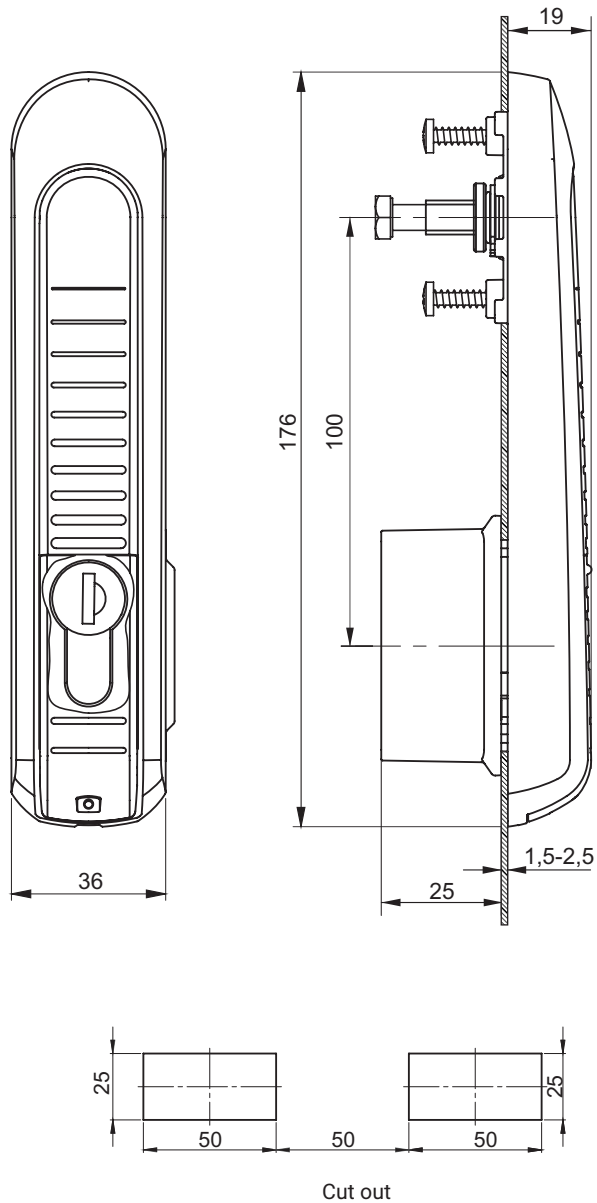

TYPE OF LOCK RS761	RS761.N	Version for a cap
	RS761.M	Version for a cogwheel mechanism

COMPONENTS	MATERIAL	FINISH [C]	
		RAL9005	RAL7035
Housing	Polyamide PA6 GF30	07	08
Handle			
Sliding dust cover			

How to order : **RS761.N** — **[C]**
 Type of lock _____
 Finish _____

All components to order separately for version under a cap and a cogwheel mechanism are shown in charts, check pg. 1B-21
 Patented insert to order separately, check pg 1C-1 to 1C-2.

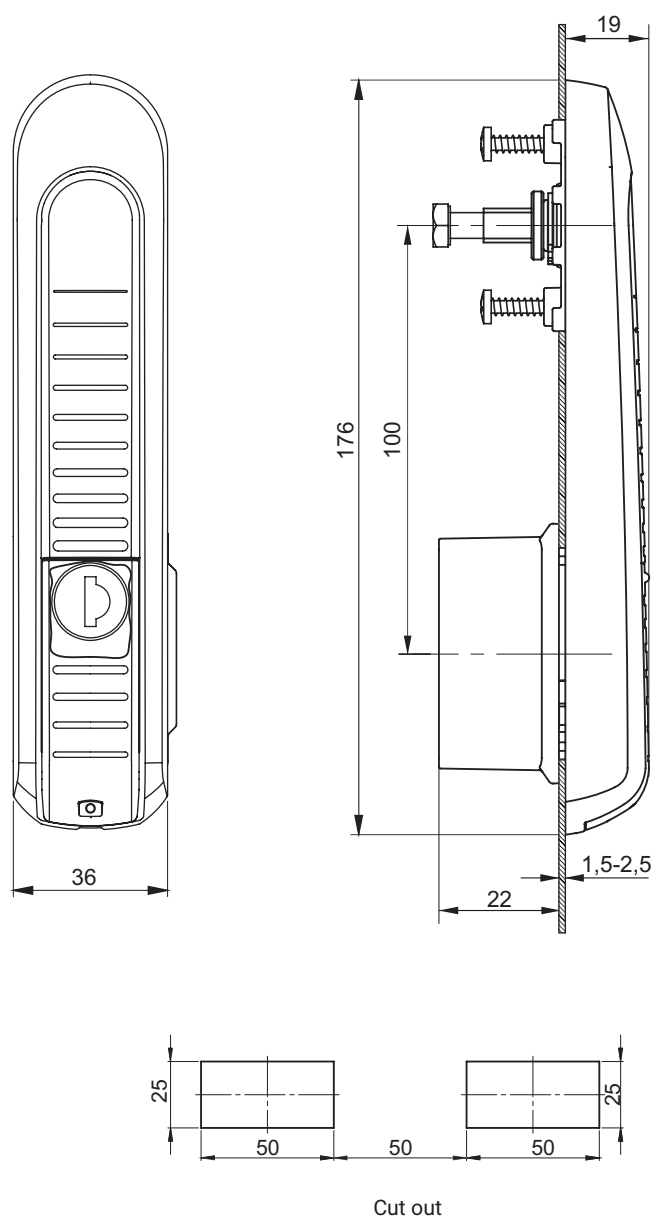

TYPE OF LOCK RS762	RS762.N	Version for a cap
	RS762.M	Version for a cogwheel mechanism

COMPONENTS	MATERIAL	FINISH [C]		Cylinder profile					Different code RK
		RAL9005	RAL7035	Key code					
Housing	Polyamide PA6 GF30	07	08	1333	405E	455E	1242E	2342E	
Handle									
Sliding dust cover									

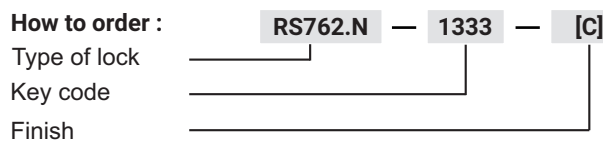

All components to order separately for version under a cap and a cogwheel mechanism are shown in charts, check pg. 1B-21

Swinghandle version for a cap

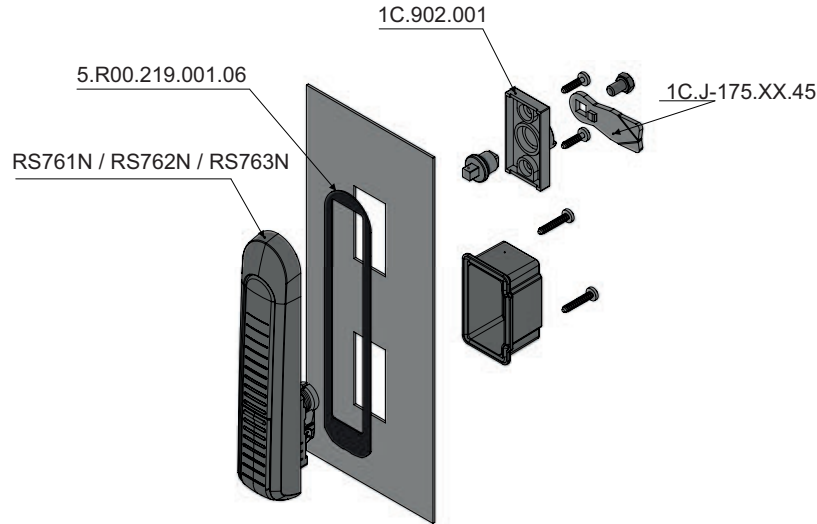

Components ordered separately		
TYPE OF LOCK	DETAIL	PAGE
RS761.N RS762.N RS763.N	Cap 1C.902.001 / 1C.902.003	1C-27
	1-point cam, group: 11, 13	1C-10, 1C-11
	2-point cam, group: 21	1C-15
	3-point cam, group: 31, 33	1C-17, 1C-18
	Rods	1C-4, 1C-5
	Rod guide	1C-6
	Gasket IP65 5.R.00.219.001.06	-

Locks for the gear mechanism

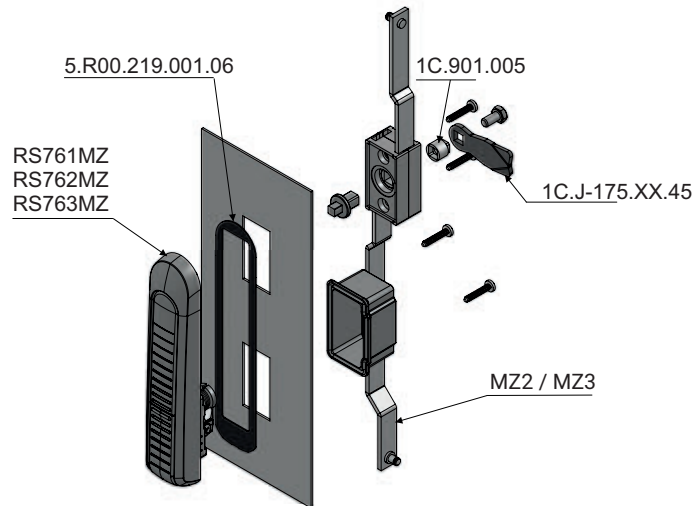

Components ordered separately		
TYPE OF LOCK	DETAIL	PAGE
RS761.M RS762.M RS763.M	Cogwheel mechanism MZ2 / MZ3	1C-30 - 1C-32
	1-point cam, group: 11, 13	1C-10, 1C-11
	Bushing 1C.901.005	1C-27
	Flat rod	1C-34 - 1C-40
	Flat rod guide and brackets	1C-6, 8, 1C-35 - 1C-40
	Gasket IP65 5.R.00.219.001.06	-

Standard lock has a class of IP54.
In case of using an additional gasket number 5.R00.219.001.06 (to be ordered separately), the lock has a class of IP65.

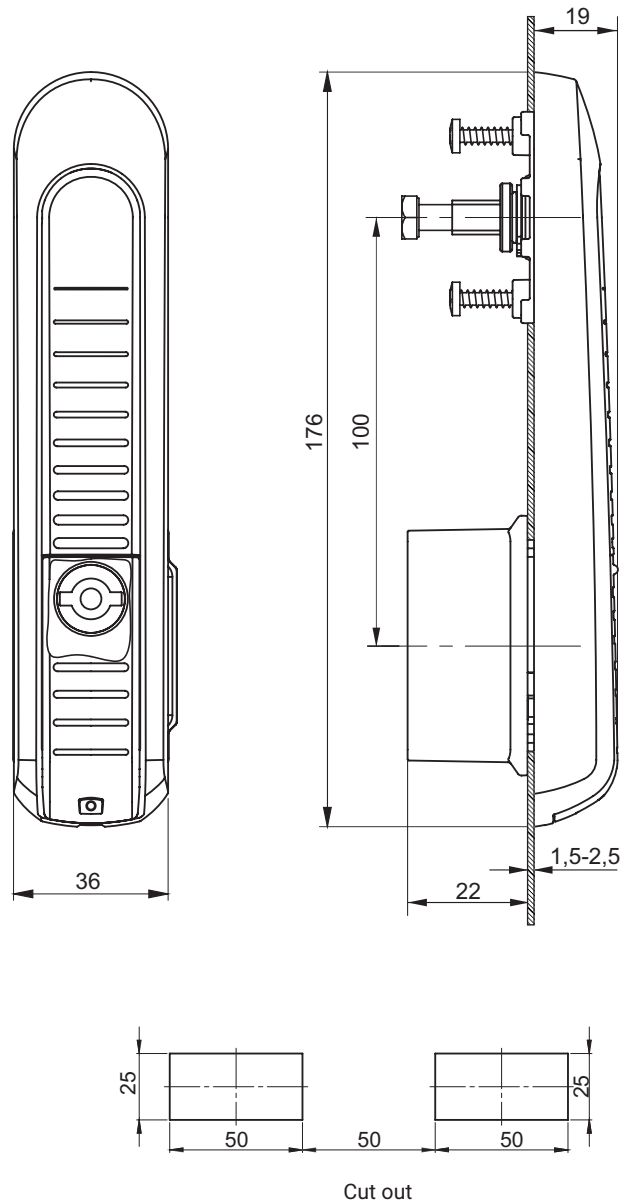

TYPE OF LOCK RS763	RS763.N	Version for a cap
	RS763.M	Version for a cogwheel mechanism

COMPONENTS	MATERIAL	FINISH [C]		Shaped profile						
		RAL9005	RAL7035	Inserts						
Housing	Polyamide PA6 GF30	07	08	D3	D5	T8	T9	KW8	S	N
Handle										
Sliding dust cover										

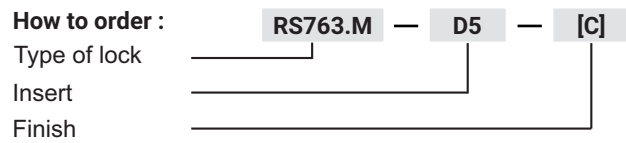

All components to order separately for version under a cap and a cogwheel mechanism are shown in charts, check pg. 1B-21



Mounting hole

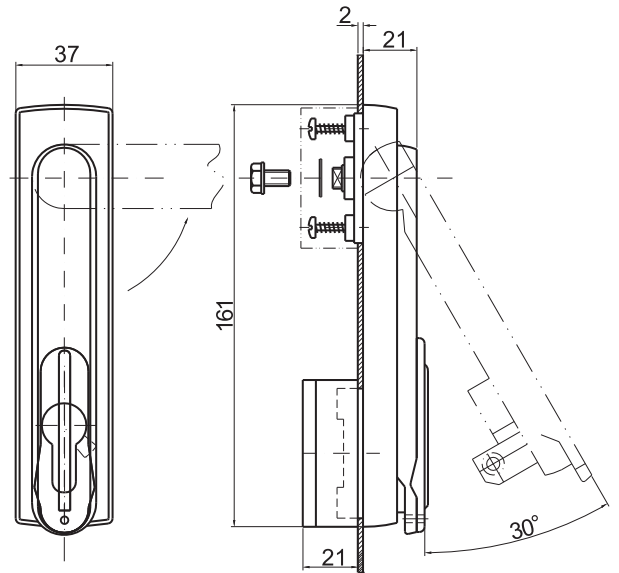
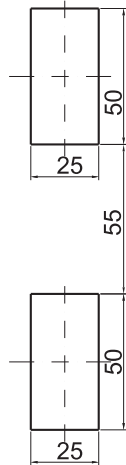

TYPE OF LOCK	COMPONENTS	MATERIAL	FINISH [C]	
			RAL9005	RAL7035
RS300.N RS300.M	Body, Handle,	Polyamide PA6 GF30	07	08



Mounting hole

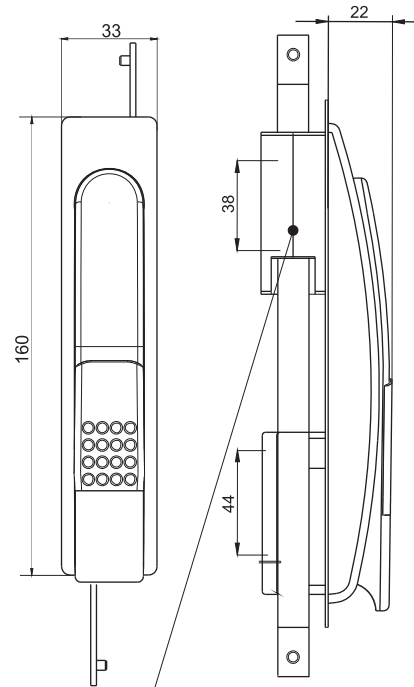
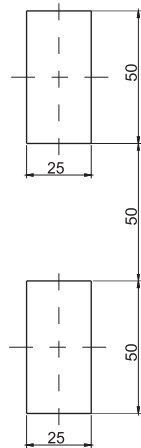

Cogwheel mechanism, page 1C-30-33

TYPE OF LOCK	COMPONENTS	MATERIAL	FINISH [C]	
			RAL9005	RAL7035
RS750.N RS750.M	Body, Handle,	Polyamide PA6 GF30	07	08

How to order :

Type of lock

Finish

RS750.M — [C]

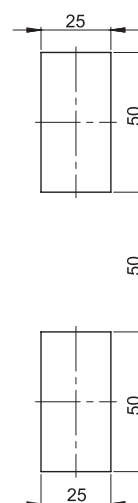
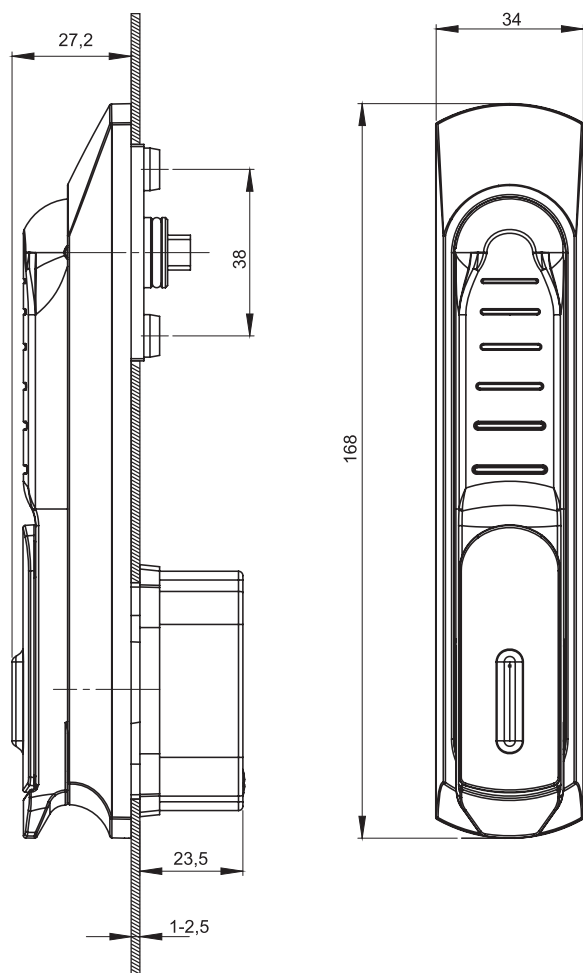

Cut out



Swinghandle for Scandinavian cylinder.
Cylinder not included.

TYPE OF LOCK	VERSION	COMPONENTS	MATERIAL	FINISH [C]
				RAL 9005
RS790.N	For a cap	Housing, Handle, Sliding dust cover	Polyamide	07
RS790.M	For a cogwheel mechanism	Housing, Handle, Sliding dust cover	Polyamide	07

How to order :

Type of lock

Finish

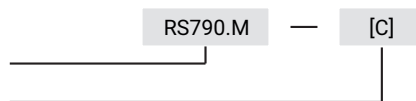

All components to order separately for version under a cap and a cogwheel mechanism are shown check pg. 1C-30 - 1C-32

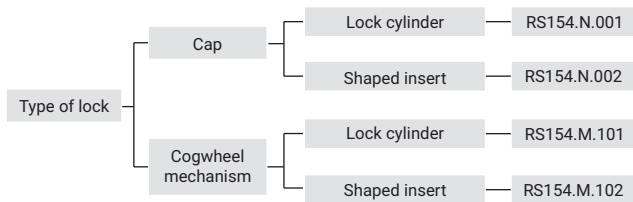
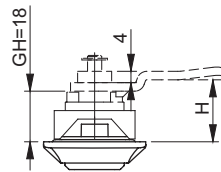
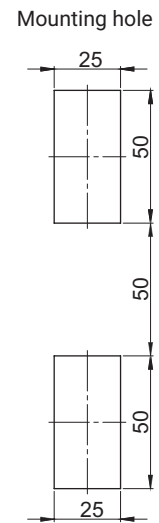
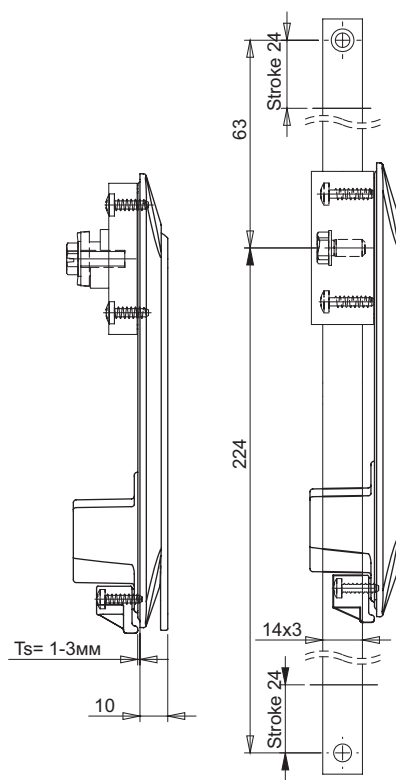
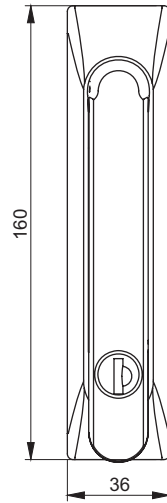

COMPONENTS	MATERIAL	FINISH [C]		LOCK CYLINDER		SHAPED INSERT	
		RAL 9005	RAL 7035	KEY CODE		INSERT	
Body	PA6 GF30	07	08	Different code RK	1333	T9	KW8
Handle		07	08				
Cap		07	-				
Adapter	ZAMAK	-	-				
Cogwheel mechanism	PA6 GF30	07	-				
Tie-rod MZ	Steel*	Zinc plated					

How to order:

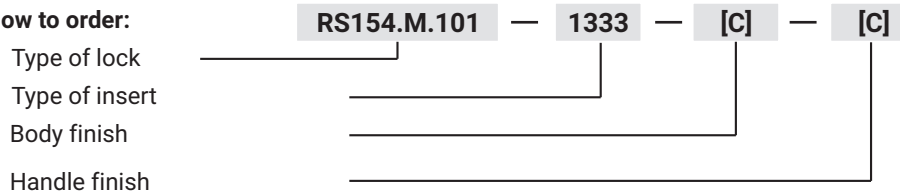

Lock comes as a set in version for cogwheel mechanism or a cap.
 All necessary components are attached.

Additional components ordered separately, check page:

- 1 point cam (group: 11, 13)..... pg: 1C-10, 1C-11
- 2 point cam JA-20018 ver. 3 (group: 21)..... pg: 1C-15
- 3 point cam (group: 38) pg: 1C-22
- Rods..... pg: 1C-4, 1C-5-7
- Flat rod..... pg: 1C-34 to 1C-40

Notes:

Ts- mounting sheet thickness
 *stainless steel tie-rod available

RS150.N

RS150.M

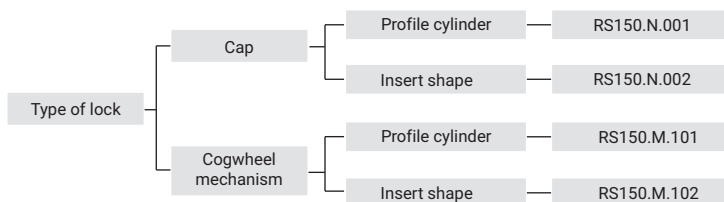
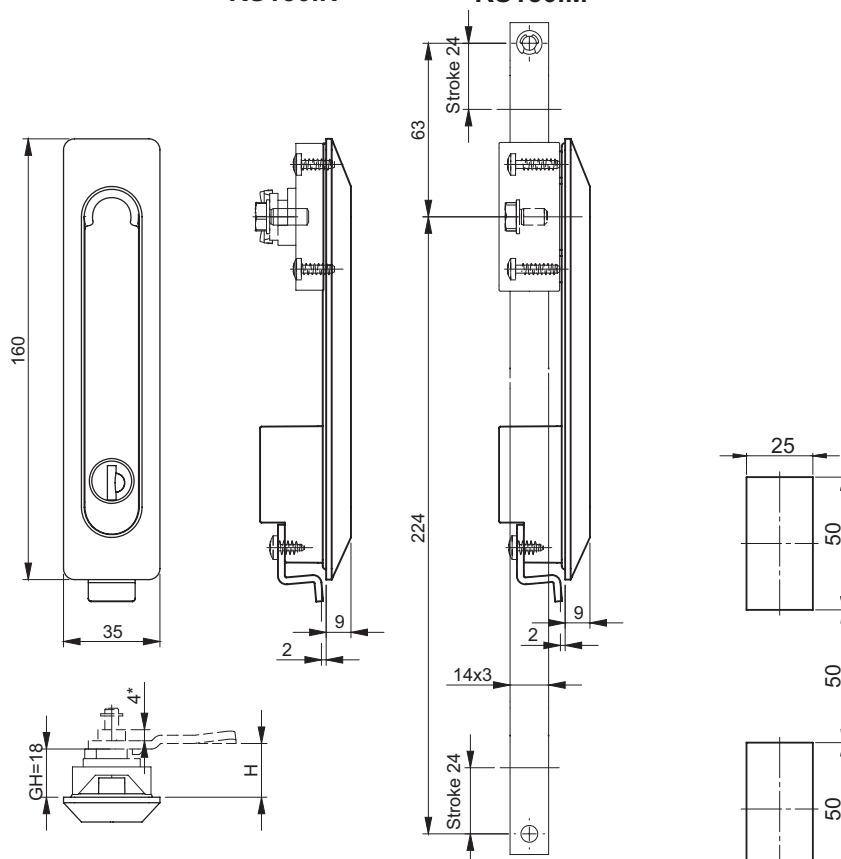

Mounting hole

COMPONENTS	MATERIAL	FINISH			PROFILE CYLINDER		INSERT SHAPE	
		CHROM	RAL 9005	RAL 7035	KEY CODE		INSERT	
Body	PA6 GF30	-	07	08	Different code RK	1333	T9	KW8
Handle	ZAMAK	01	04	05				
Cap	PA6 GF30	-	07	-				
Cam adapter	ZAMAK	-	-	-				
Cogwheel mechanism	PA6 GF30	-	07	-				
Tie-rod MZ	Steel	Zink plated						

How to order:

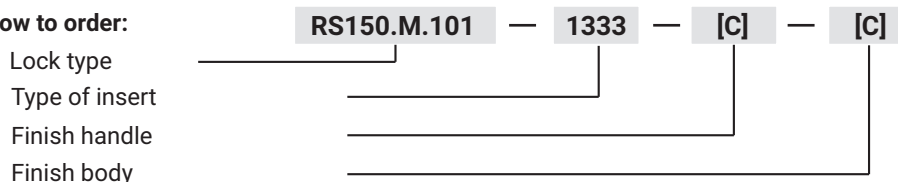

Lock comes in a set in version for cogwheel mechanism and for a cap.

All components for assembly are attached in a set.

Additional components ordered separately, check page:

- 1 point cam (group: 11, 13)..... pg: 1C-10, 1C-11
- 2 point cam JA-20018 ver. 3 (group: 21)..... pg: 1C-15
- 3 point cam (group: 38)..... pg: 1C-22
- Rods..... pg: 1C-4, 1C-5-7
- Flat rods..... pg: 1C-34 to 1C-40

Tie-rods of cogwheel mechanism available in stainless steel



RS980

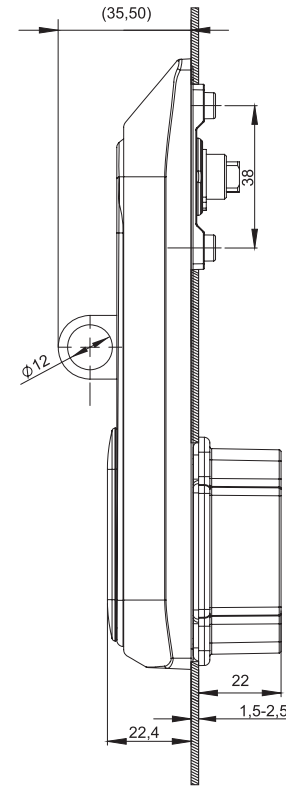
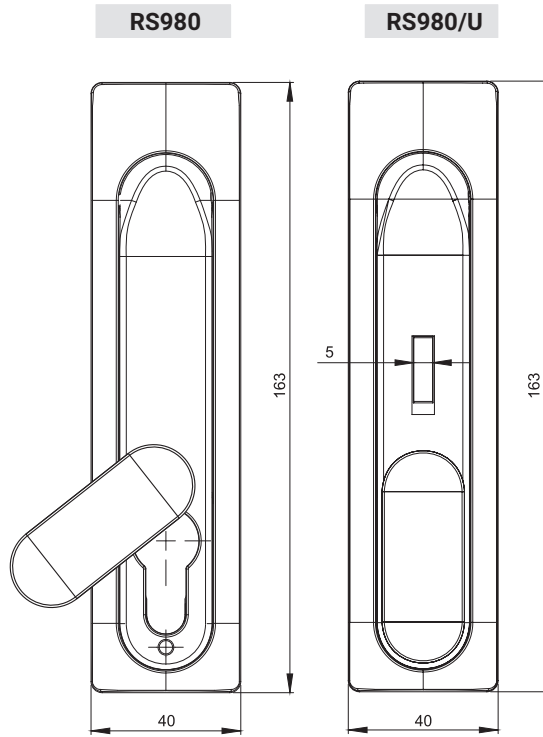

RS980/U

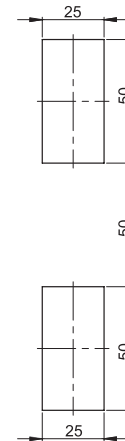

Cut out

Swinghandle in accordance with RC2 ENV 1630 standard
 The lock has the **security level** in accordance with **DIN EN 50102**
 The handle and housing **resistant to strain**.
 Lock has a protection class IP 65
 Lock from material ZAMAK 5
 Patented insert to order separately, check pg. 1C-1, 1C-2

TYPE OF LOCK	VERSION	COMPONENTS	MATERIAL	FINISH [C]
				RAL 9005
RS980.N	For a cap	Housing, Handle, Sliding dust cover	ZAMAK	04
RS980/U.N		Housing, Handle, Sliding dust cover, Padlock device		
RS980.M	For a cogwheel mechanism	Housing, Handle, Sliding dust cover	ZAMAK	04
RS980/U.M		Housing, Handle, Sliding dust cover, Padlock device		

How to order : RS980.M — [C]
 Type of lock _____
 Finish _____

All components to order separately for version under a cap and a cogwheel mechanism are shown check pg. 1C-30 - 1C-32

Version N

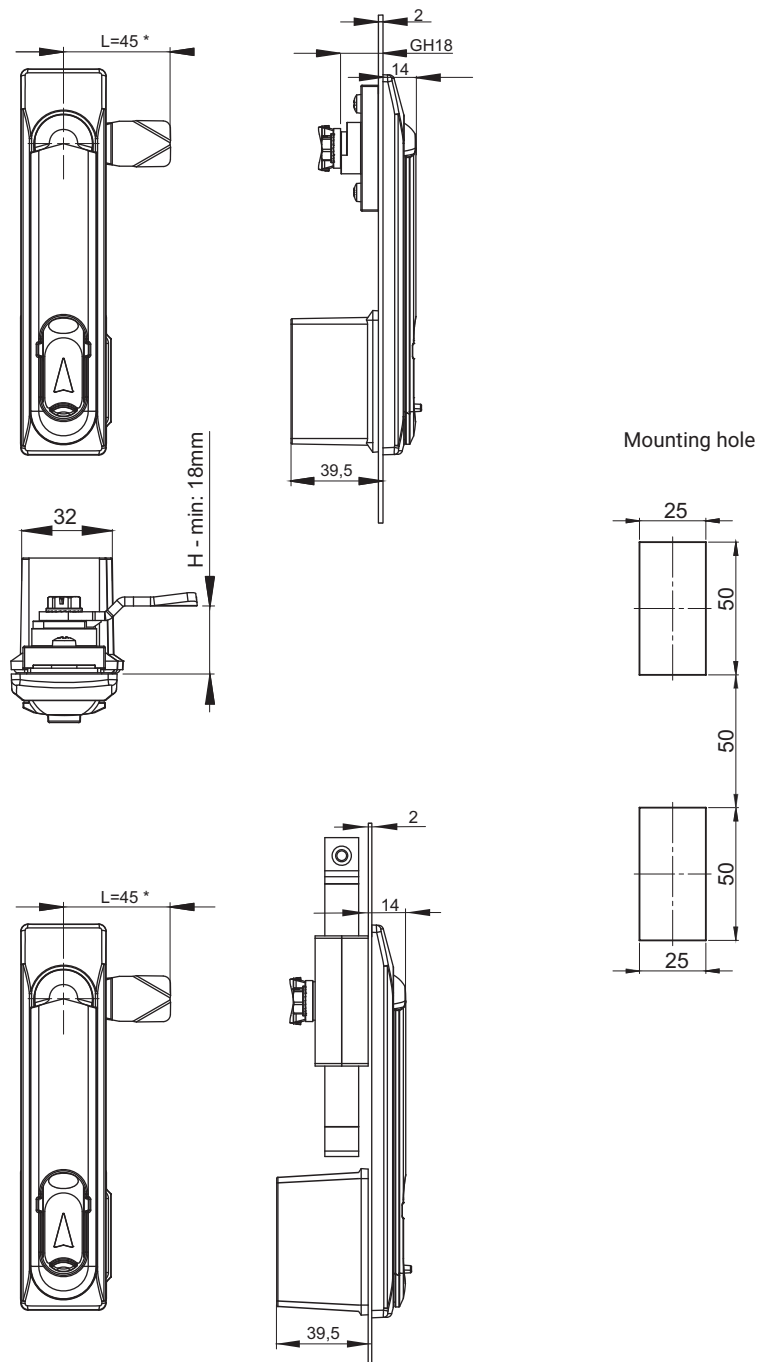

Version M

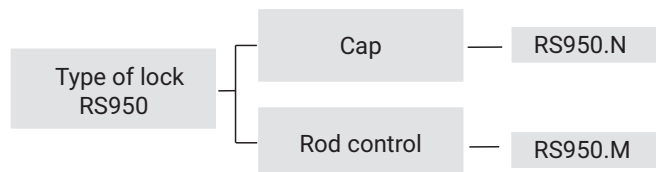

TYPE OF LOCK	COMPONENTS	MATERIAL	FINISH [C]
			RAL9005
RS950	Body, Handle	ZAMAK5	04

How to order :
 Type of lock — **RS950.N**
 Finish — **[C]**

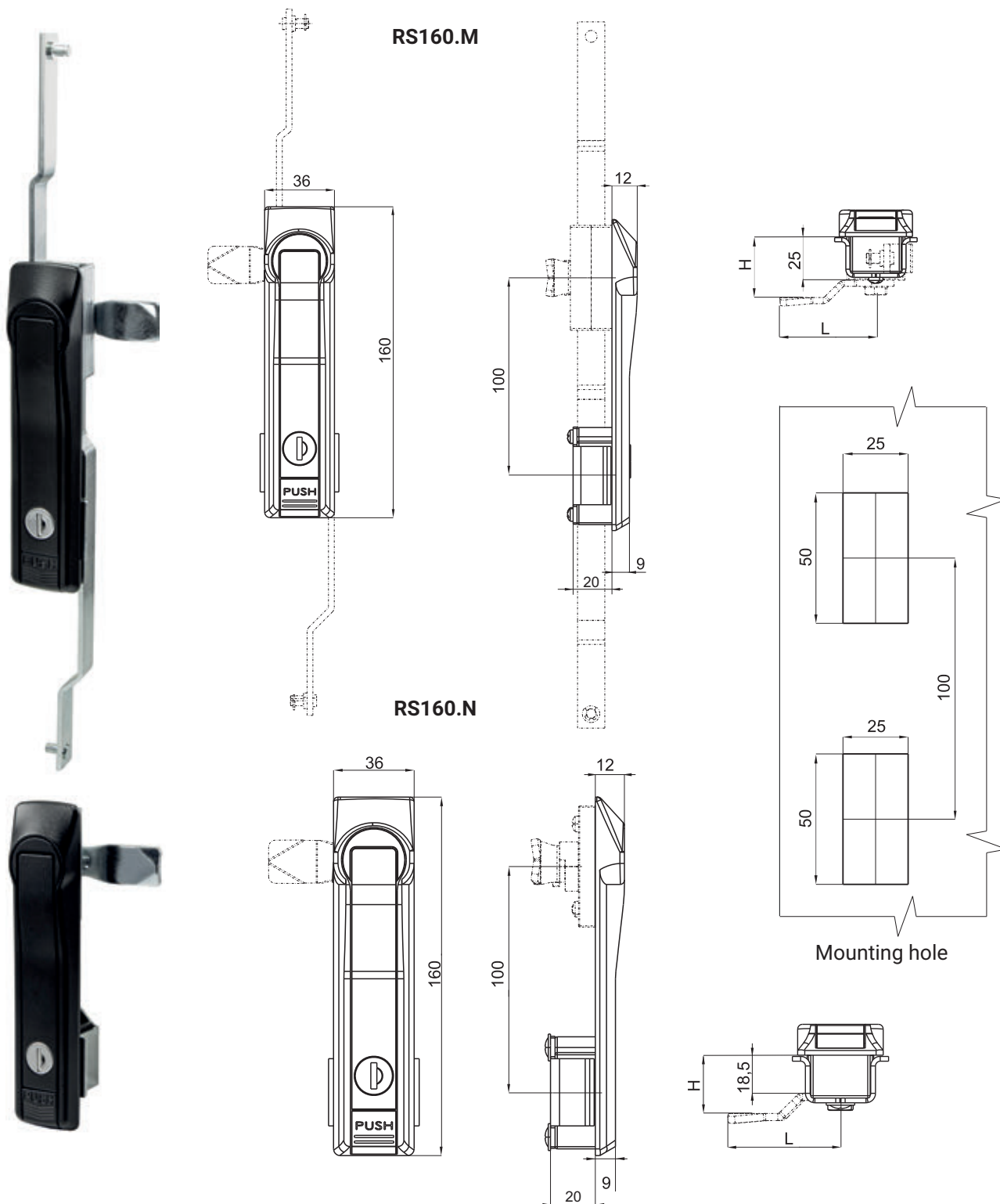

TYPE OF LOCK	COMPONENTS	MATERIAL	FINISH [C]	
			Chrome	RAL 9005
RS160.N	Body	Polyamide	-	07
RS160.M	Handle	ZAMAK5	01	04

How to order :
 Type of lock
 Finish body
 Finish handle



RS161.N

RS161.M

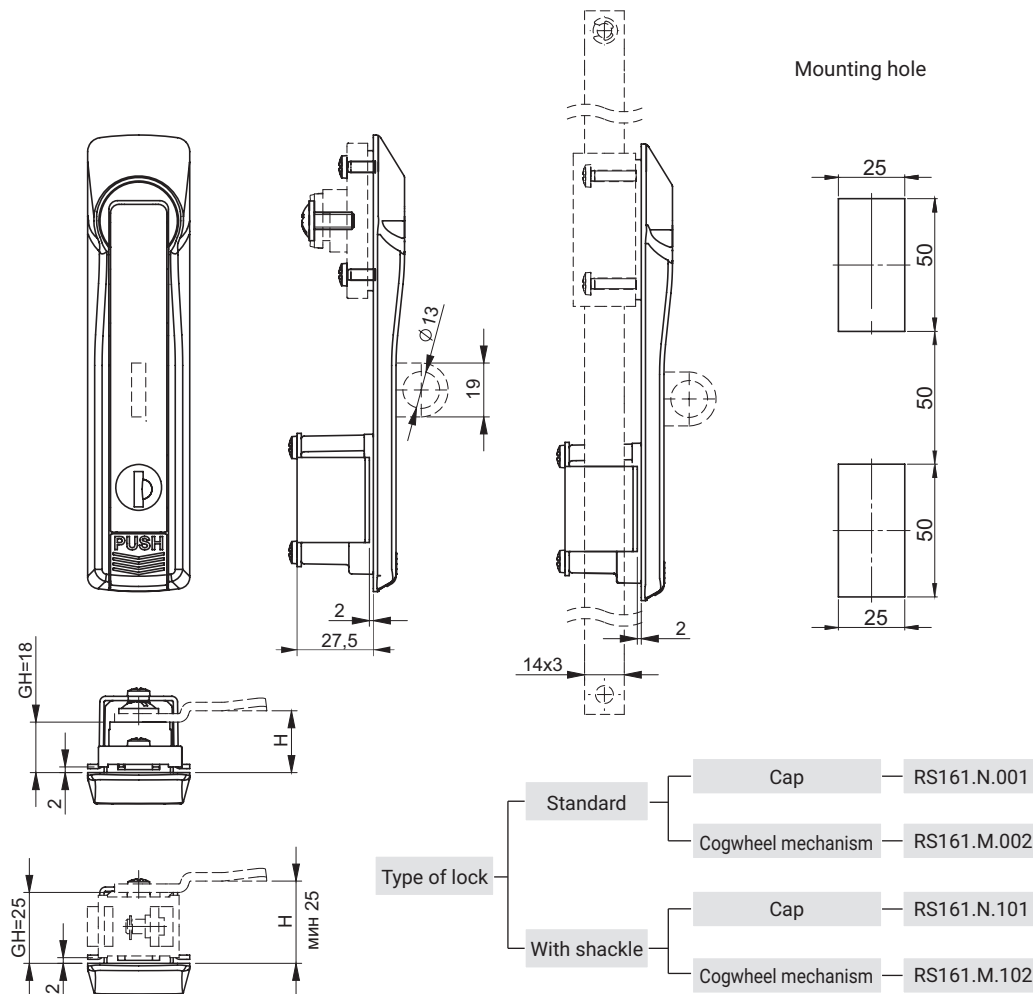

Standard version



Version with shackle

COMPONENTS	MATERIAL	FINISH [C]			LOCK CYLINDER	
		CHROME	RAL 9005	CHROME SATYNA	KEY CODE	
Body	ZAMAK5	01	04	09	Different code RK	1333
Handle		01	04	09		
Clamp*	Steel	O cynk galwaniczny				

How to order:

- Type of lock
- Type of insert
- Housing finish
- Handle finish

RS161.M.101 — **RK** — **[C]** — **[C]**

Additional components ordered separately check page:

- Cap 1C.902.001.....pg: 1C-27,
- Cogwheel mechanism MZ2, MZ3.....pg: 1C-30 to 1C-33,
- Cam adapter 1C.903.001.....pg: 1C-27,
- 1 point cam (group: 11, 13).....pg: 1C-10, 1C-11,
- Rods.....pg: 1C-4, 1C-5, 1C-7
- Flat rods.....pg: 1C-34 to 1C-40

Notes:

Lock RS161MZ is compatible with cogwheel mechanism MZ2 and MZ3.
 While using 1 point cam with cogwheel mechanism ordering can adapter (1C.903.001) (pg 1C-27) and screw M6X23 is a necessity.
 * Stainless steel available.



RS174.001

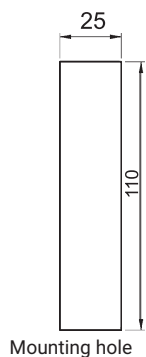

Mounting hole

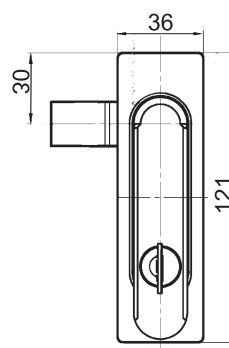
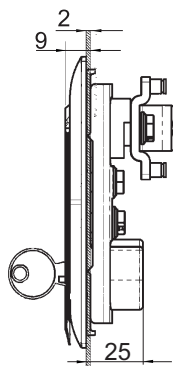

RS174.002

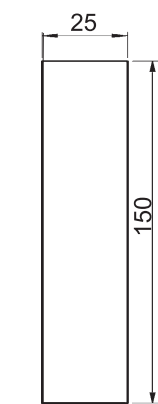

Mounting hole

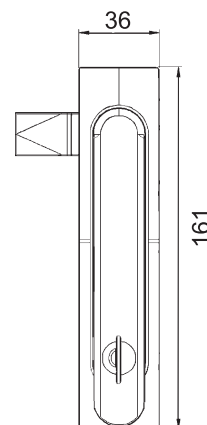
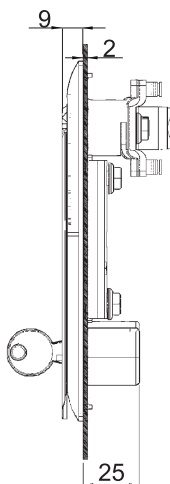

RS175.001

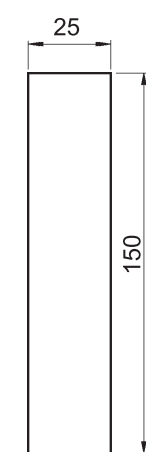

Mounting hole

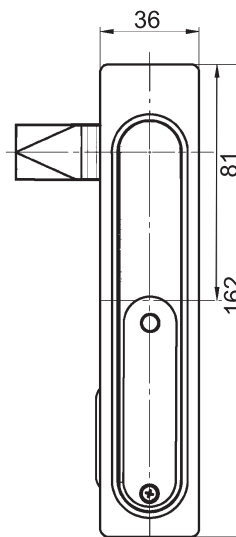
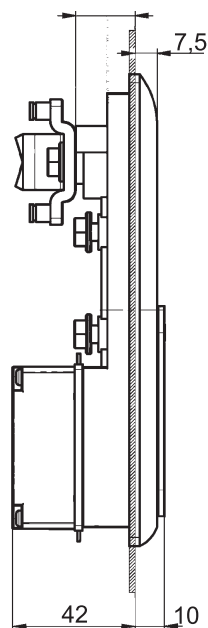

TYPE OF LOCK	COMPONENTS	MATERIAL	FINISH [C]
			RAL 9005
RS174.001 RS174.002 RS175.001	Body, Handle	ZAMAK	04

How to order :

Type of lock

Finish

RS174.002 — [C]

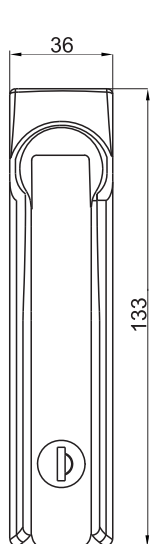

RS168
(without pin)

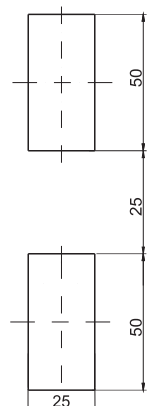
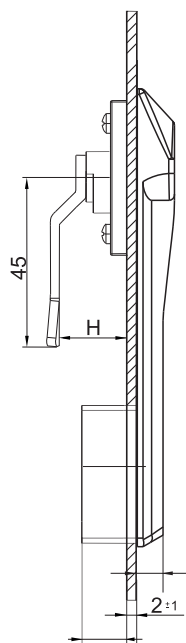

Mounting hole

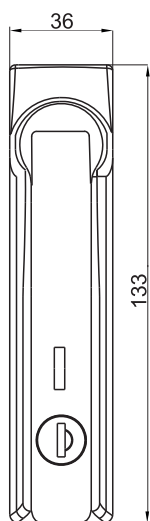

RS168/B
(with pin)

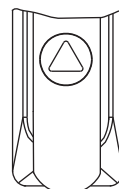
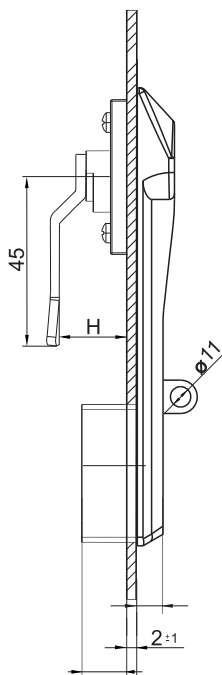

Version B

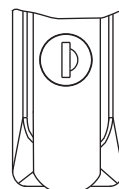

Version A



TYPE OF LOCK	COMPONENTS	MATERIAL	VERSION		FINISH [C]
					RAL 9005
RS168 RS168B	Body, Handle	ZAMAK	A	B	04

How to order :

Type of lock
Lock version
Finish



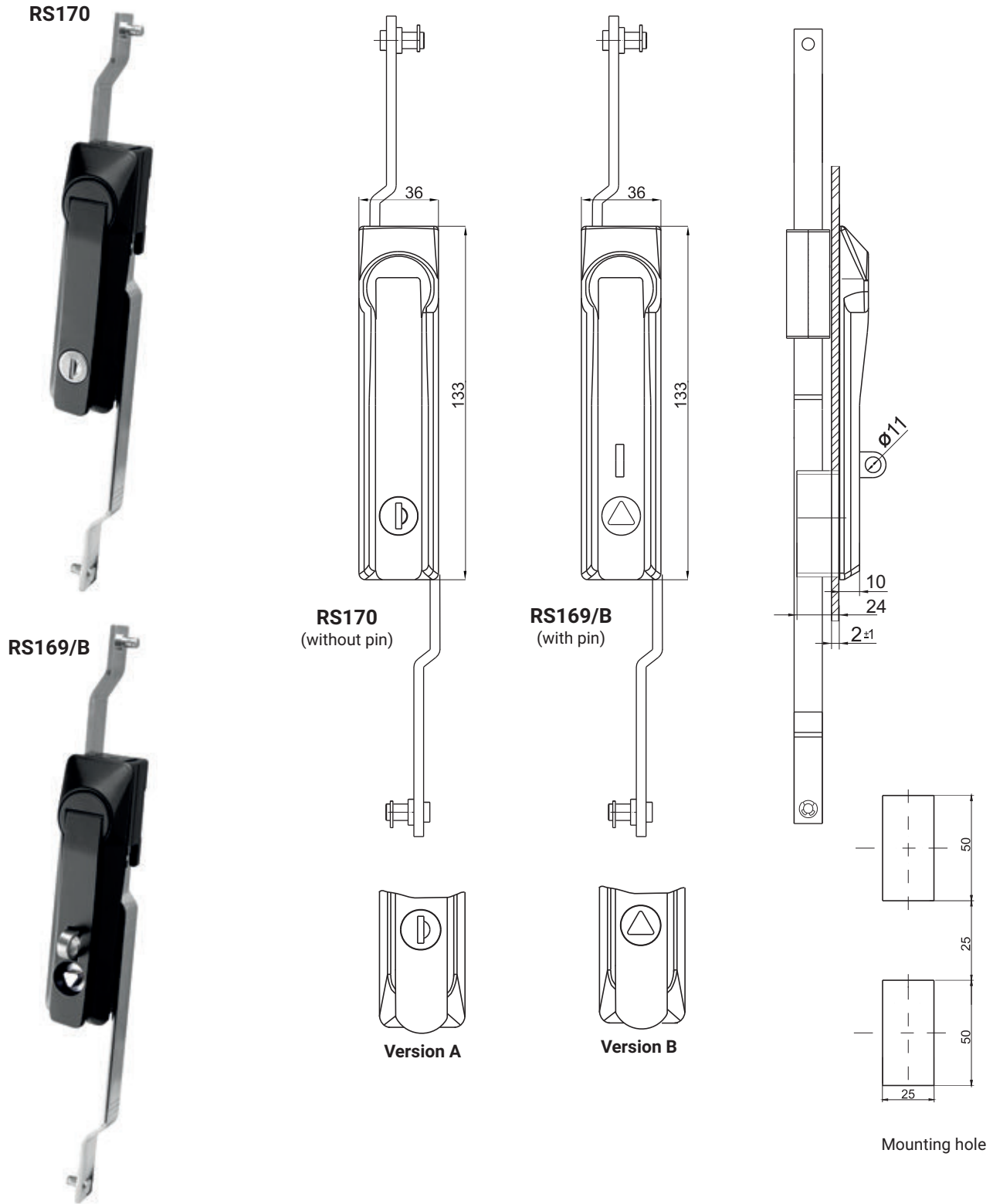

TYPE OF LOCK	COMPONENTS	MATERIAL	VERSION		FINISH [C]
					RAL 9005
RS169B RS170	Body, Handle	ZAMAK	A	B	04

How to order :

Type of lock
Lock version
Finish

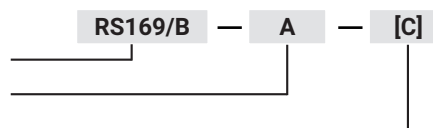

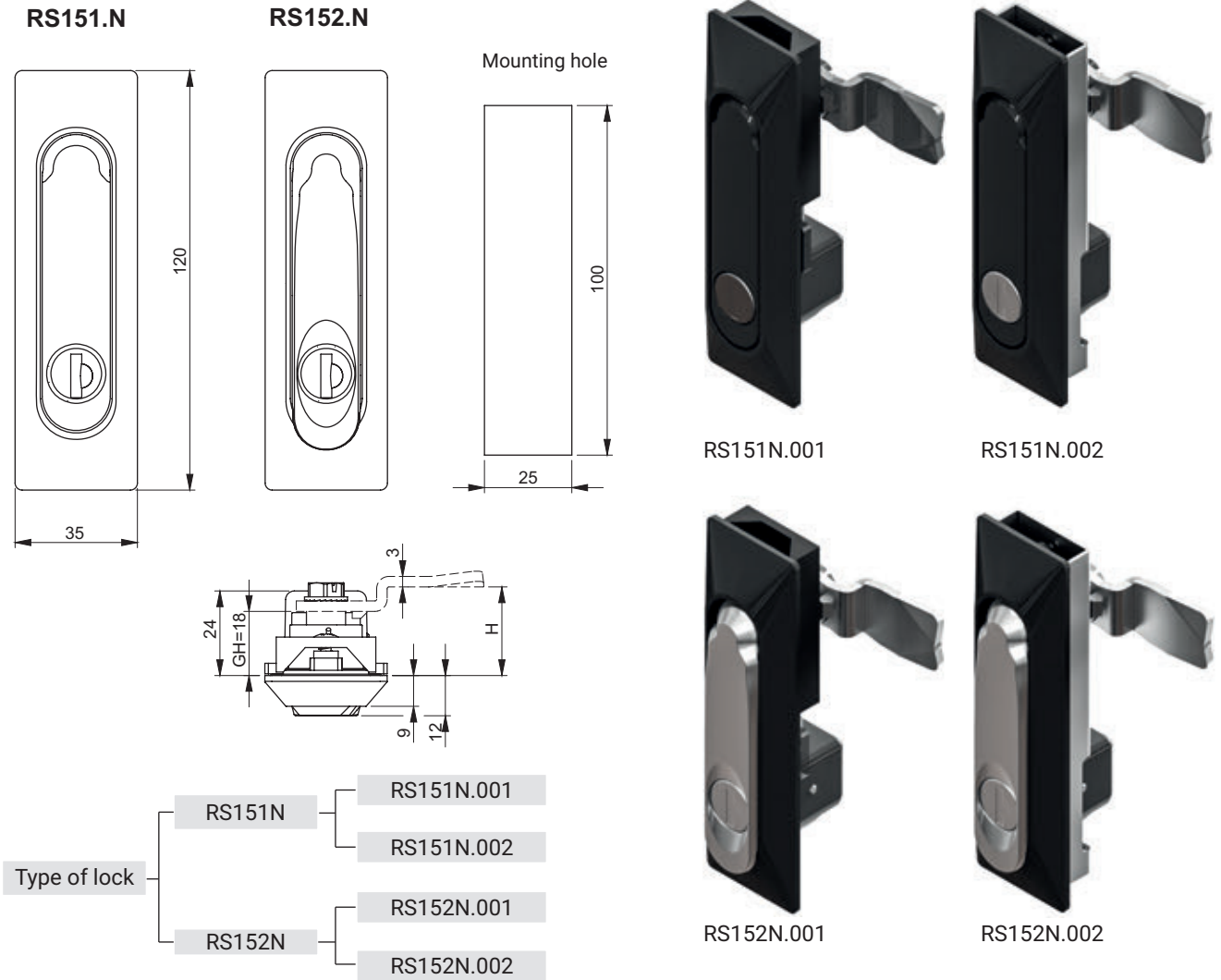

COMPONENTS	MATERIAL	FINISH [C]			LOCK CYLINDER	SHAPED INSERT	
		CHROME	RAL 9005	RAL 7035		KEY CODE	INSERT
Body	PA6 GF30	-	07	08	Different code RK 1333	INSERT	
Handle RS151	PA6 GF30	-	07	08		T9	KW8
Handle RS152	ZAMAK	01	04	05			
Cam adapter 1C.903.003	ZAMAK	-	-	-			
Cap 1C.902.005	PA6 GF30	-	07	-			
Mounting components	Steel zinc plated						

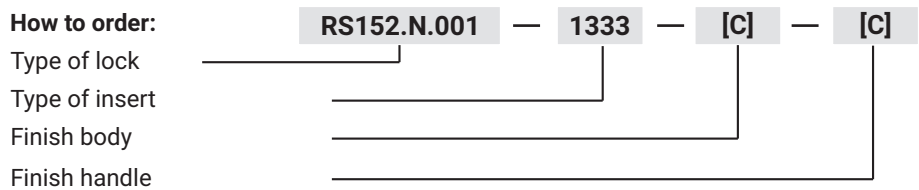

All necessary components are attached with a set.
 For locks RS151N and RS152N CAMS to be ordered separately:
 - 1 point cam (group: 11, 13).....pg: 1C-10, 1C-11

Mounting method .001

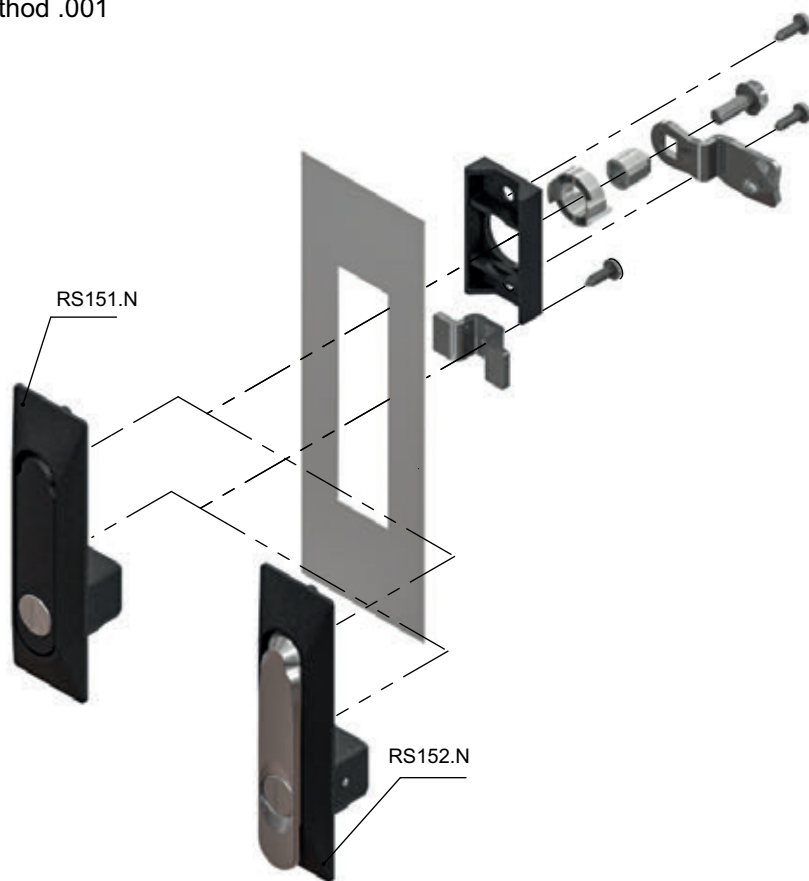

Mounting method .002

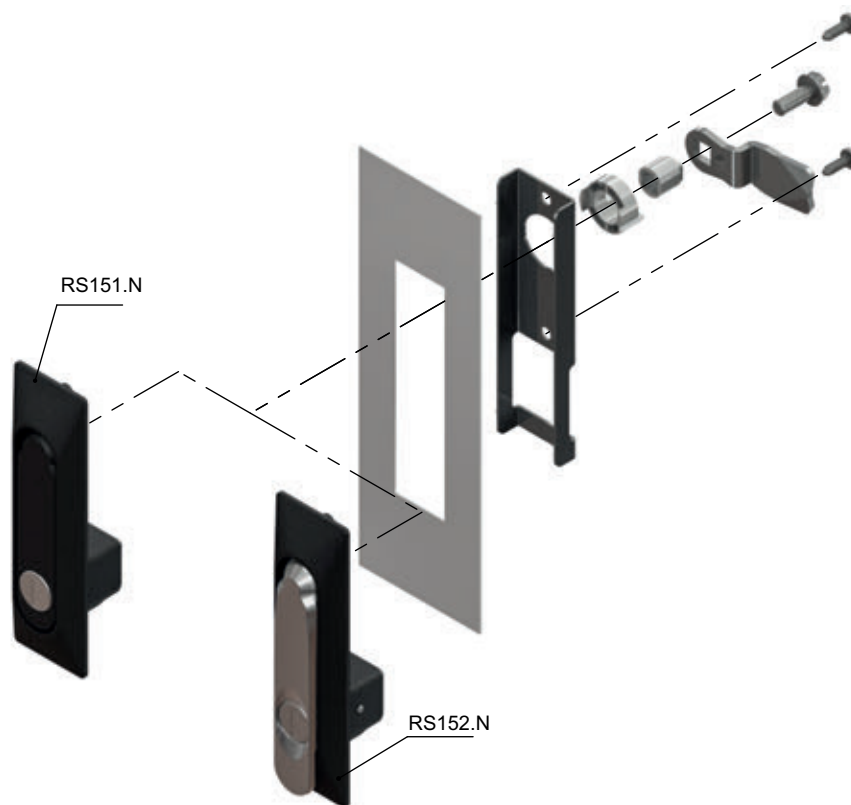

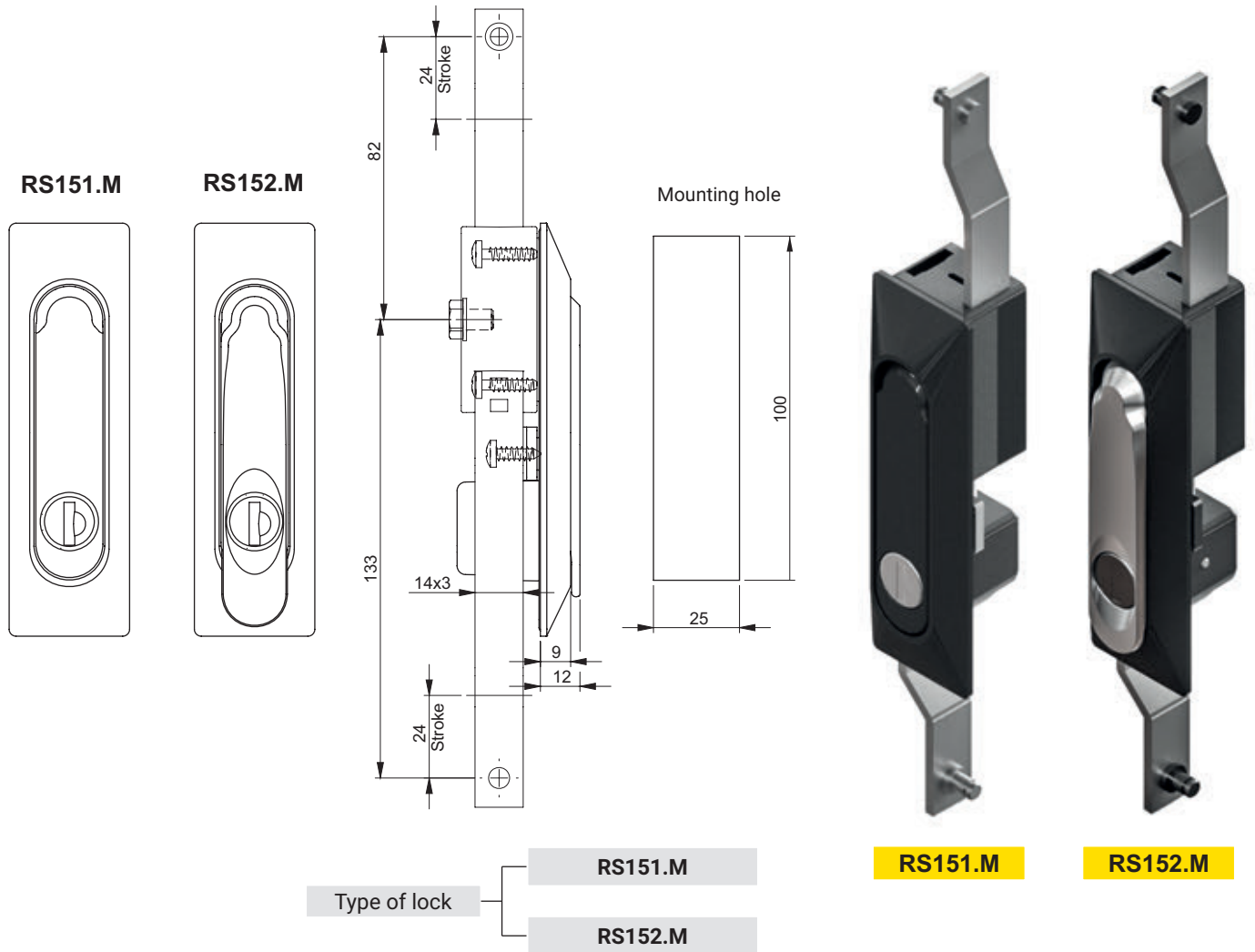

COMPONENTS	MATERIAL	FINISH [C]			CYLINDER LOCK		SHAPED INSERT	
		CHROME	RAL 9005	RAL 7035	KEY CODE	1333	T9	KW8
Body	PA6 GF30	-	07	08				
Handle RS151	PA6 GF30	-	07	08				
Handle RS152	ZAMAK	01	04	05				
Cap MZ	PA6 GF30	-	07	-				
Tie-rod MZ	Steel zink plated							
Mounting components	Steel zink plated							

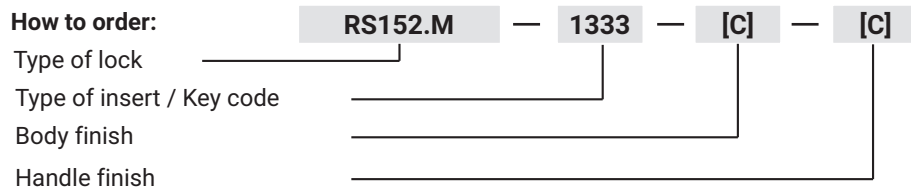

All necessary components are attached with a set.
 Additional components ordered separately check page:
 - Rods.....pg: 1C-4, 1C-5, 1C-7
 - Flat rods.....pg: 1C-34 TO 1C-40.
 * Chrome finish available only for RS152.N (metal handle-ZAMAK5).

RW100.N

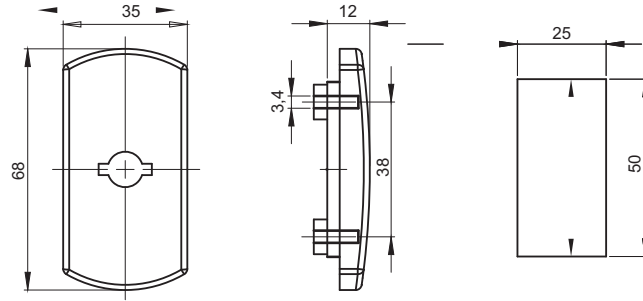

RW100.N
(Used with Cap)

RW100.M
(Used with Cogwheel mechanism)

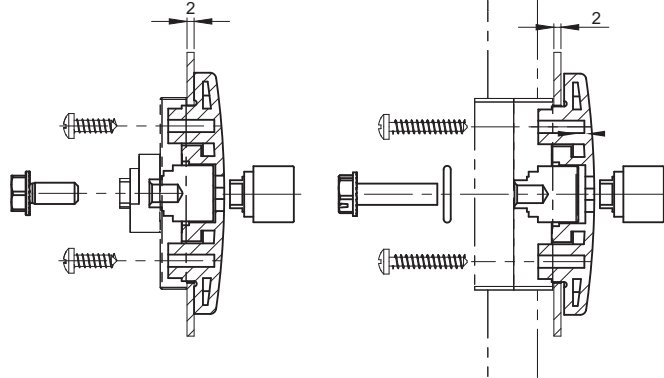

RW110.N

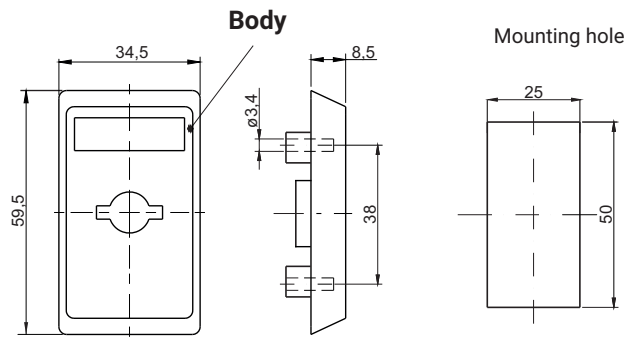

RW110.N ...
(Used with Cap)

RW110.M ...
(Used with Cogwheel mechanism)

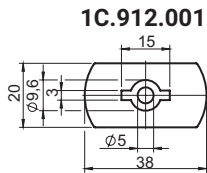
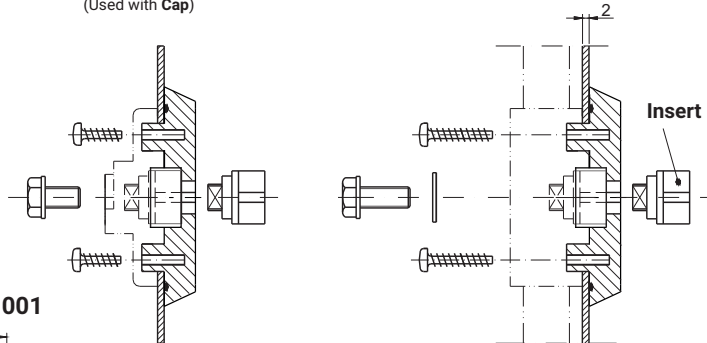

Protective cover compatible with locks: RW100, RW110, RW400

NOTE:
Additional components
of locks:
RW100.N, RW100.M,
RW110.N, RW110.M,
on pages: 1A-5, 1A-6.

TYPE OF LOCK	COMPONENTS	MATERIAL	FINISH [C]
			RAL 9005
RW100.N, RW100.M RW110.N, RW110.M	Body	Polyamide PA6 GF30	07
1C.912.001	Protective cover	Polyamide	07

How to order :

Type of lock

Finish

RW110.N — [C]

| Swinghandles

www.roztocze.eu

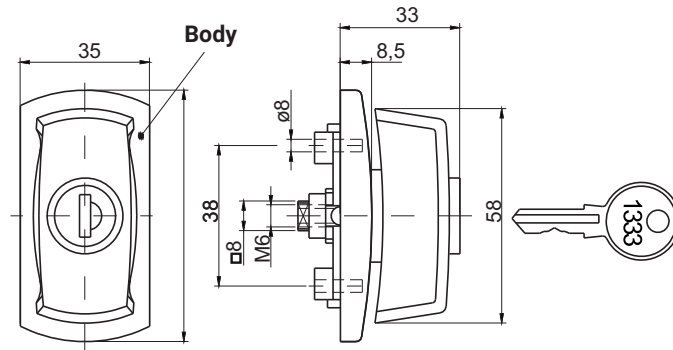

RW200.N ...
(Used with Cap)

RW200.M ...
(Used with Cogwheel mechanism)

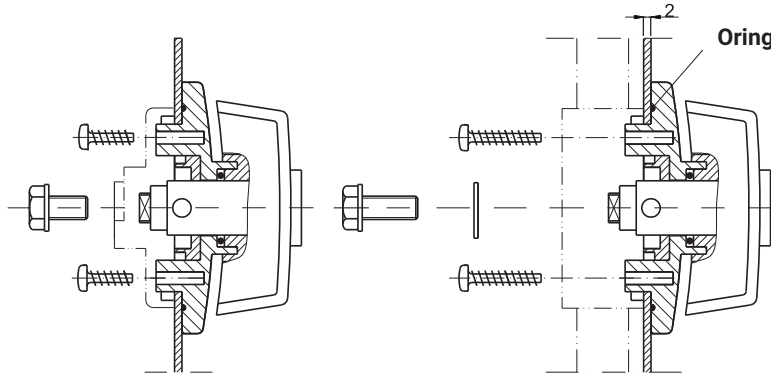

NOTE:
Additional components
of locks:
RW200.N, RW200.M,
on pages: 1A-5, 1A-6.

TYPE OF LOCK	COMPONENTS	MATERIAL	FINISH [C]
RW200.N RW200.M	Body	Polyamide PA6 GF30	RAL 9005
			07

How to order :
Type of lock **RW110.N** — **[C]**
Finish

WING-KNOB LOCK RW500

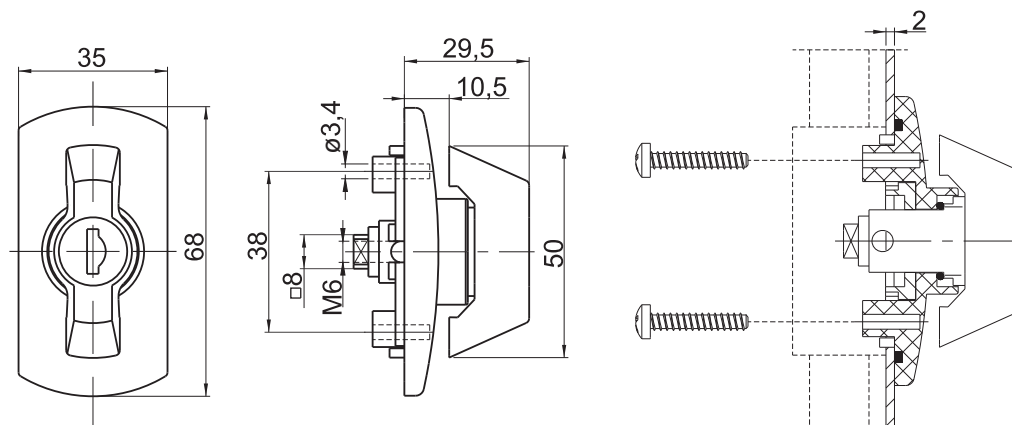

TYPE OF LOCK			COMPONENTS	MATERIAL	FINISH [C]
Insert code1333	Different code	No insert			RAL 9005
1B.RW500.001	1B.RW500.002	1B.RW500.003	Body	Polyamide PA6 GF30	07
			Knob		ZAMAK

MZ1-DB.002, MZ1K-DB.002, MZ1P-DB.002

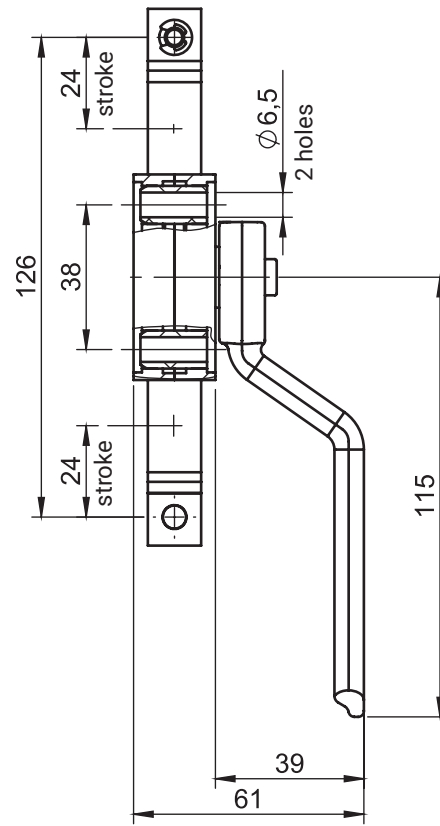
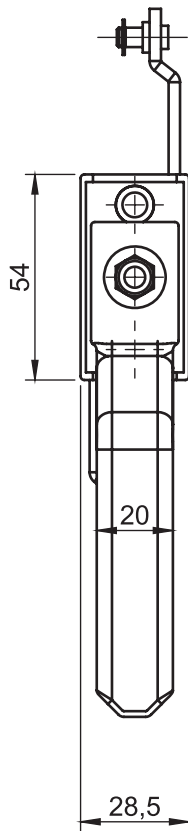

Flat Rod, page 1C-34 - 1C-40

Rod guide P314, page 1C-8

CATALOGUE NUMBER	VERSION	COMPONENTS	MATERIAL
MZ1-DB.002	Retaining washers protection	The body of the mechanism	ZAMAK
MZ1K-DB.002	Square protection	Tie-rod	Stal ocynkowana
MZ1P-DB.002	Shape protection	Inner handle	Poliamid

T-HANDLE LOCK RW510

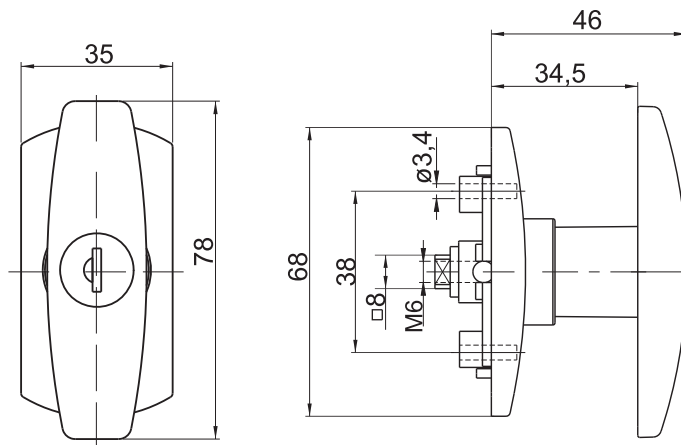

TYPE OF LOCK			COMPONENTS	MATERIAL	FINISH [C]
Insert code1333	Different code	No insert			RAL 9005
1B.RW510.001	1B.RW510.002	1B.RW510.003	Body	Polyamide PA6 GF30	07
			Handle T	ZAMAK	04

How to order : **1B.RW510.001** — **[C]**
 Type of lock _____
 Finish _____

L-HANDLE LOCK RW520

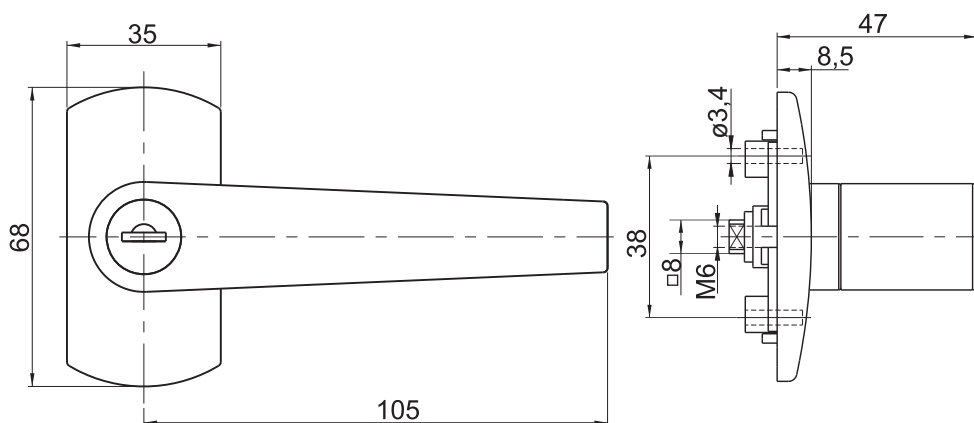

TYPE OF LOCK			COMPONENTS	MATERIAL	FINISH [C]
Insert code1333	Different code	No insert			RAL 9005
1B.RW520.001	1B.RW520.002	1B.RW520.003	Body	Polyamide PA6 GF30	07
			Handle L	ZAMAK	04

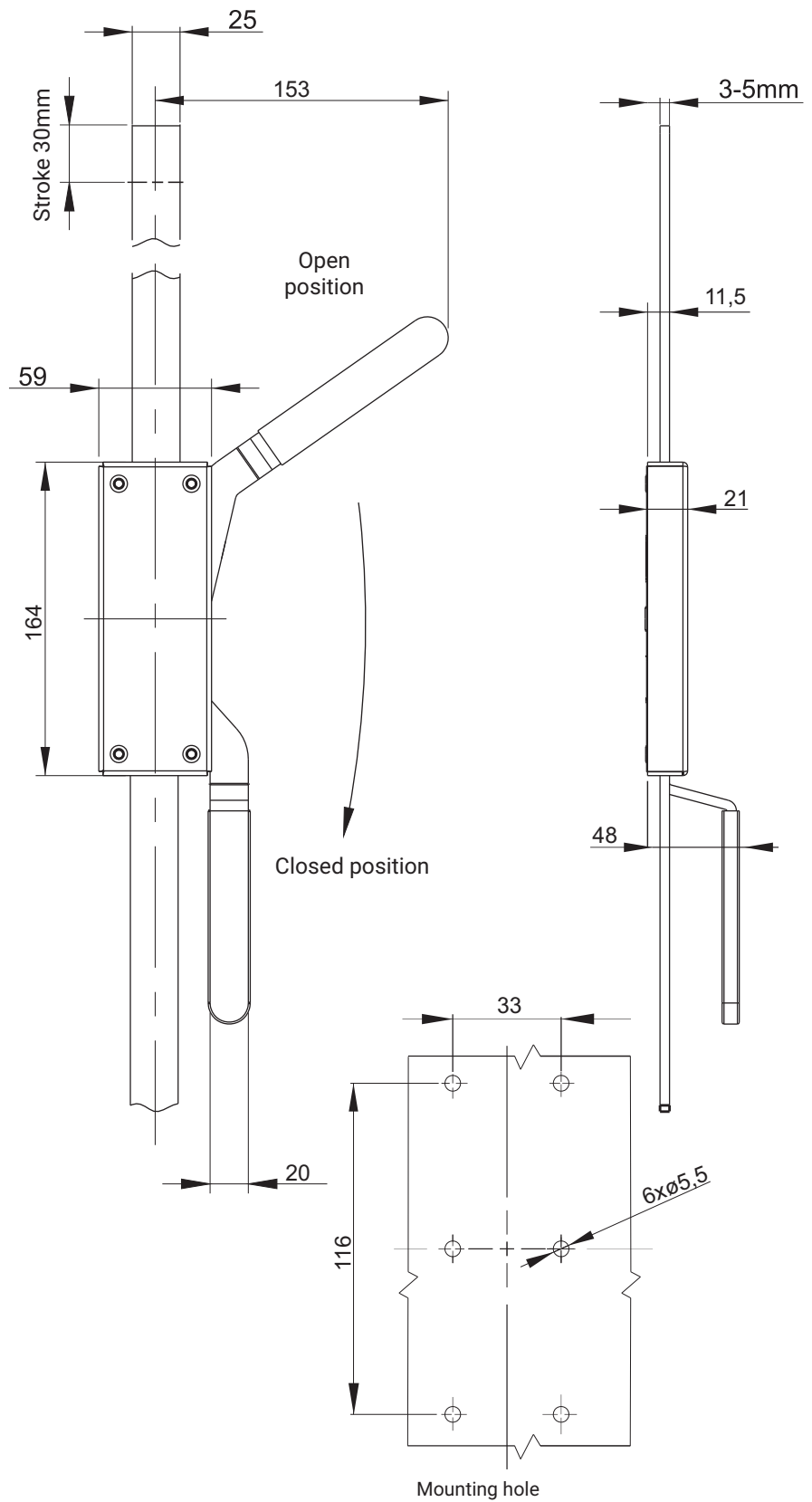

NOTE: Possibility of ordering lock with locking rods

CAT. NUMBER	NAME	MATERIAL
1B.530.001 - Right	Internal Lock ZWDB	Steel zinc plated
1B.530.002 - Left		

1B-41

| Swinghandles

www.roztocze.eu

ZWA1 lock driven by a swinghandle

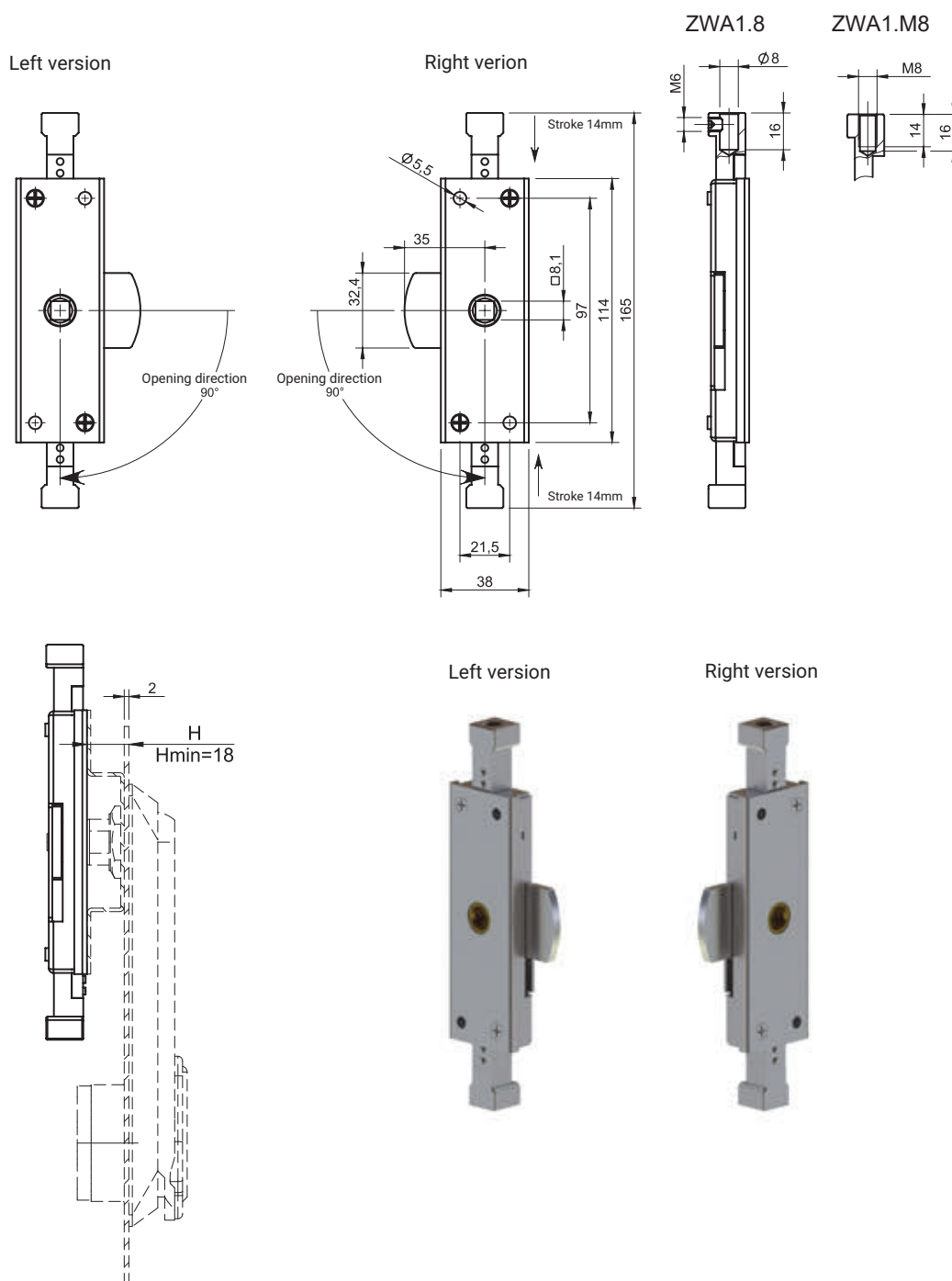

Lock ZWA1 works with the swinghandle RS130, page 1B-8 and with the swinghandle RS200, page 1B-3.
 When ordering the RS lock to cooperate with the ZWA1 lock, add the end of ZWA1 to the catalogue number of the RS lock

CAT. NUMBER	VERSION	METHOD OF ATTACHING THE ROD	MATERIAL
1B.ZWA1.8.101	Right	Hole ø8	Steel zinc plated
1B.ZWA1.M8.101		Threaded hole m8	
1B.ZWA1.8.102	Left	Hole ø8	
1B.ZWA1.M8.102		Threaded hole m8	

ZWA2 lock driven by a quarter turn lock

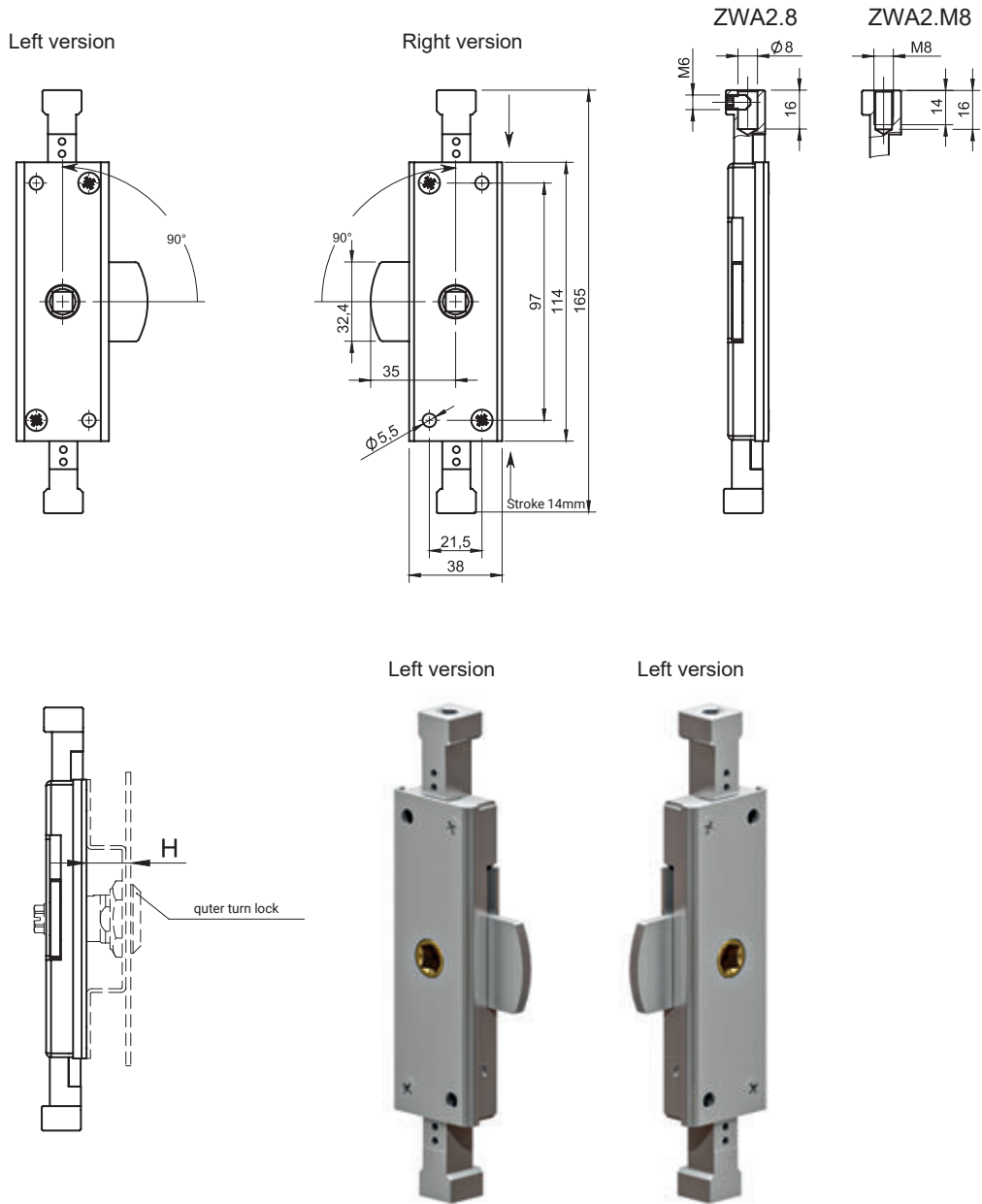

ZWA2 lock works with quarter turn locks M22-2, M22-30, M22-40, M22-60, 2.L, 2.T, 2.PM. The height H is equal to the height GH of the lock used. When ordering a quarter turn lock which is to cooperate with the ZWA2 lock, the ZWA2 end-piece should be added to the catalogue number of the lock.

DRIVE LOCK	HEIGHT H [mm]
M22-3, 2.L18, 2.T18, 2.PM18	18
M22-30, 2.L30, 2.T30 2.PM30	30
M22-40, 2.L40, 2.T40, 2.PM40	40
M22-60, 2.L60, 2.T60, 2.PM60	60

CAT. NUMBER	VERSION	METHOD OF ATTACHING THE ROD	MATERIAL
1B.ZWA2.8.201	Right	Hole ø8	Steel zinc plated
1B.ZWA2.M8.201		Threaded hole m8	
1B.ZWA2.8.202	Left	Hole ø8	
1B.ZWA2.M8.202		Threaded hole m8	

Lever Lock 1B.ZD100



ROZTOCZE

1B

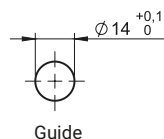
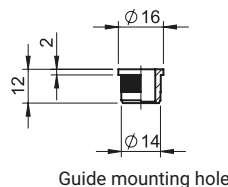
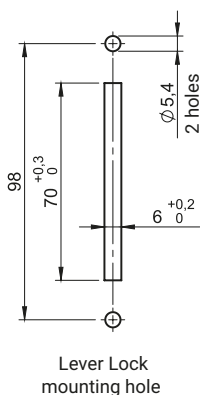
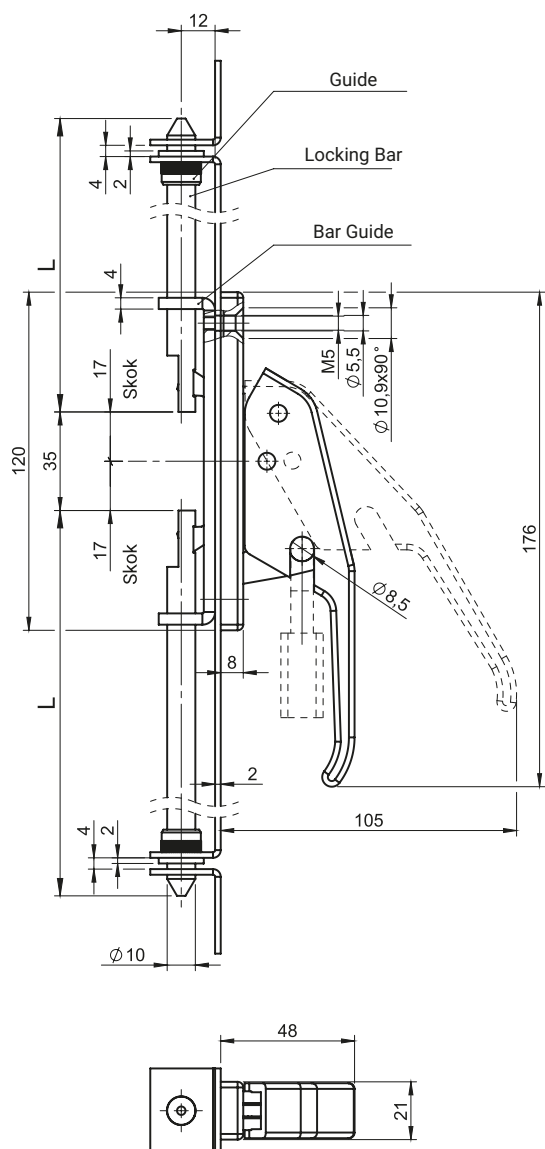

CATALOGUE NUMBER	COMPONENTS	MATERIAL	FINISH [C]
			RAL 9005
1B.ZD100.001	Lever Lock	Aluminum	04
	Bar Guide	Zinc plated steel	-
1B.ZD100.001.06	Locking Bar $\phi 10$	Zinc plated steel	-
1B.ZD100.001.07	Guide	Brass	-

When ordering the locking bar 1B.ZD100.001.06 please specify the length L.

The lock cylinder with radial pins type WCM

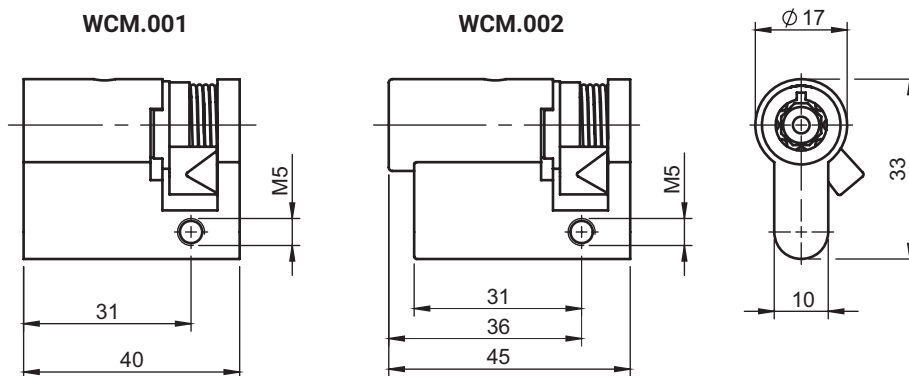

The key can be removed only from the locked position

CATALOGUE NO.	KEY TYPE	MATERIAL
WRS-WCM.001	WCM	ZAMAK
WRS-WCM.002		

SHAPED INSERT LATCHING

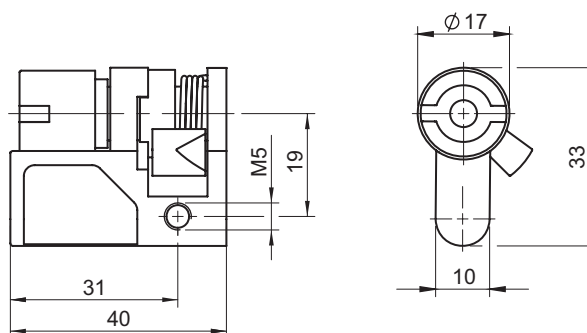

TYPE OF INSERT [X]															
D3	D5	T6	T7	T9	T10	T13i	KW6	KW7	KW8	S	N	C9	L	D13	
CATALOGUE NO.		MATERIAL			FINISH [C]										
WRS-X		ZAMAK			Nickel		Galvanized								
					02		03								

How to order:

Type of lock
Type of insert
Finish

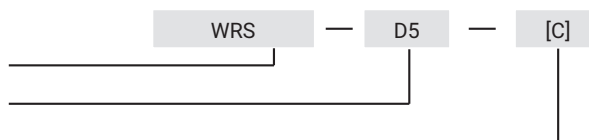

**LOCK CYLINDER
WRS-B.001**

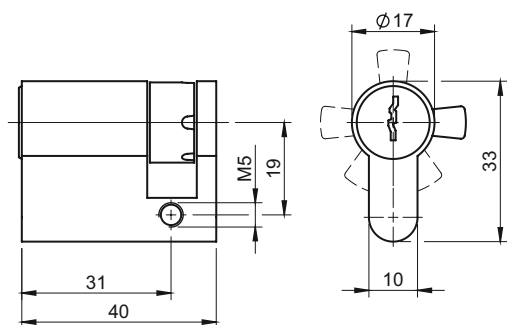

NOTE:
Profile cylinder can be ordered with one or different key codes.

**SELF-LOCKING CYLINDER
WRS-P.001**

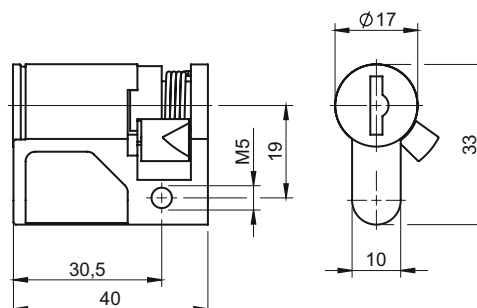

NOTE:
Profile cylinder can be ordered with one or different key codes.



CAT. NUMBER	KEY CODE	MATERIAL	FINISH [C]
WRS-B.001 - JK	Key alike	Brass	-
WRS-B.001 - RK	Different code		
WRS-P.001 - 1333	Code 1333	ZAMAK	Nickel
WRS-P.002 - 405E	Code 405E		
WRS-P.002 - 455E	Code 455E		
WRS-P.002 - 1242E	Code 1242E		
WRS-P.002 - 2342E	Code 2342E		

**Shaped insert rotated by 360°
WRS-360**

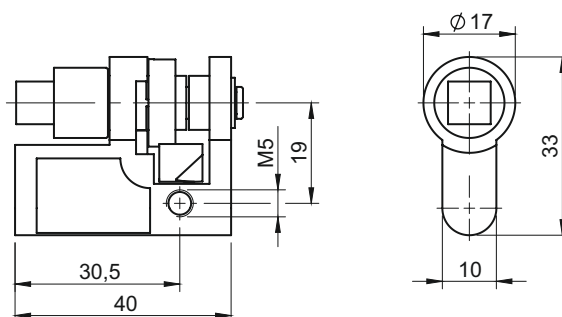

TYPE OF INSERT [X]														
D3	D5	T6	T7	T9	T10	T13i	KW6	KW7	KW8	S	N	C9	L	D13
CATALOGUE NO.		MATERIAL			FINISH [C]									
WRS-360-X		ZAMAK			Nickel		Galvanized							
					02		03							

How to order:

Type of lock
Type of insert
Finish

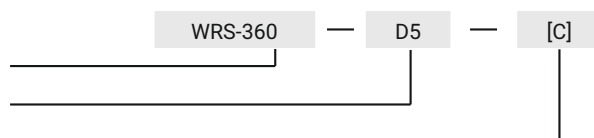



Self-locking shaped insert with difficult access
WRS-D13.001 / WRS-D13.002

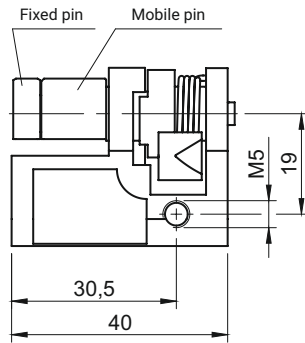

WRS-D13.001

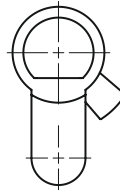

WRS-D13.002

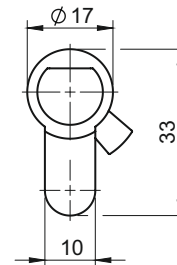

Shaped insert rotaed by 360° with difficult access
WRS-D13.003 / WRS-D13.004

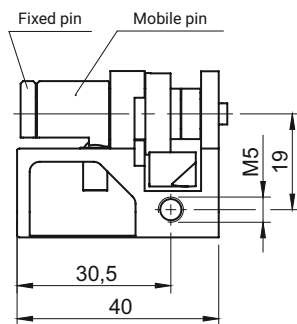

WRS-D13.003

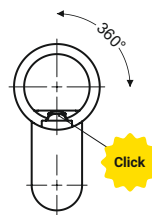

WRS-D13.004

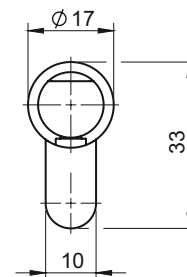

Shaped inserts WRS-D13 are compatible only with specified lock types RS: RS420, RS520, RS420/U, RS520/U.

WRS-D13.003 and WRS-D13.004 allows the key to turn 360°, removing the key is possible only in the open position, open position is signalized by a slight click.

Recommended key for cylinders with difficult access - 2.KL-D13S.008 (pg. 2A-115).

CATALOGUE NO.	COMPONENTS	MATERIAL	FINISH [C]
WRS-D13.001	Housing	ZAMAK	Nickel
WRS-D13.002	Mobile pin	ZAMAK	-
	Fixed pin	Steel zinc plated	-
WRS-D13.003	Housing	ZAMAK	Nickel
WRS-D13.004	Mobile pin	Brass	-
	Fixed pin	Steel zinc plated	-

**ROD with Cut End
(P26L)**

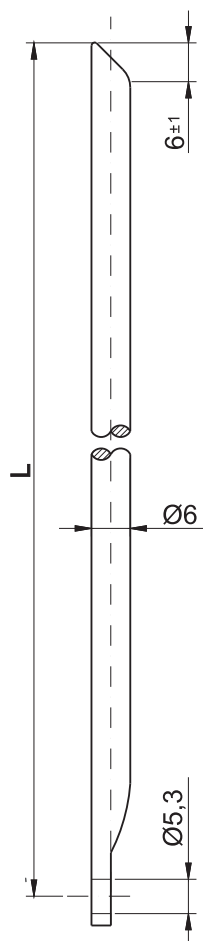

**ROD with Pointed End
(P26L)**

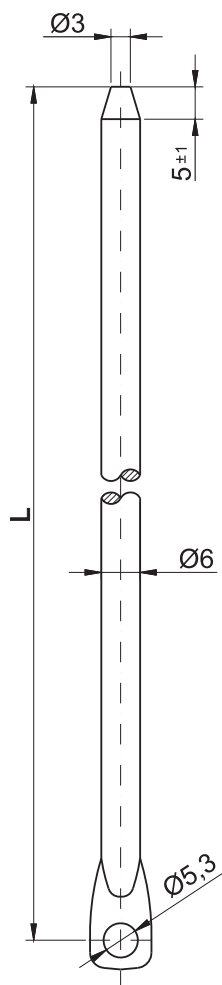

**ROD with Pointed End (regulated)
(PR28L)**

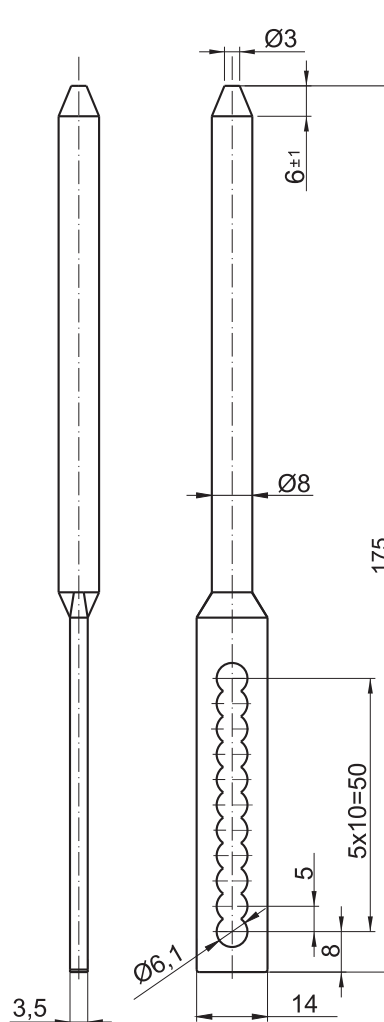

stainless steel

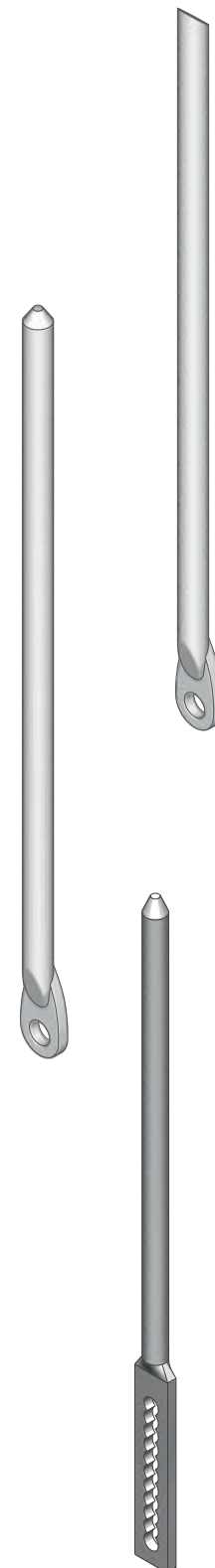

CALCULATING RODS' LENGHT

a) 3- point cam assembled in the middle of the door:

$$L = \frac{P - 12\text{mm}}{2}$$

b) in case, when cam is moved about dimension A:

L= in calculated like in point a) but:
 - upper rod $L_w = L + A$
 - lower rod $L_N = L - A$

L - lenght of rod [mm]

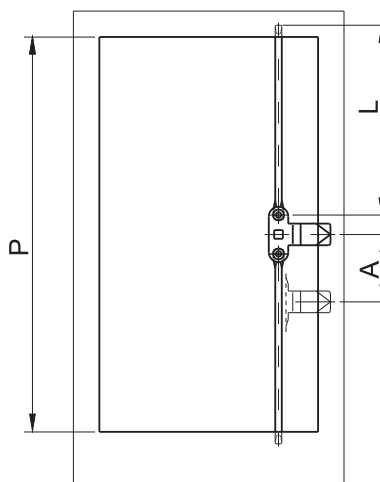

CAT. NUMBER	NAME	MATERIAL
P16 L	Rod with cut end	Steel zinc plated
P26 L	Rod with pointed end	Steel zinc plated
PR28 L	Rod with pointed end (regulated)	Steel zinc plated



**ROD with Rollers
(P38 L)**

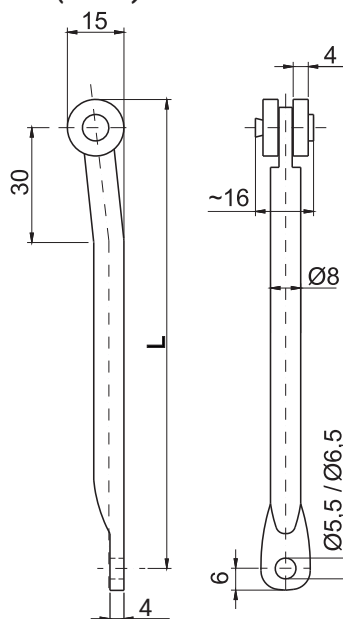

**ROD with Flat End
(P48 L)**

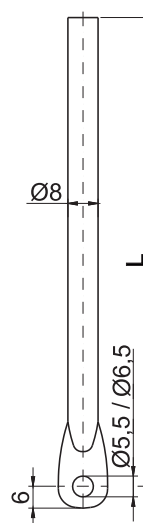

**ROD with Pointed End
(P28 L)**

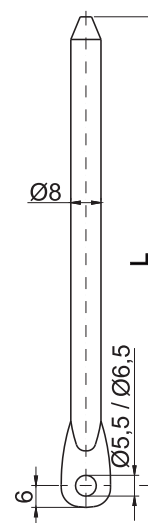

**ROD wit Rollers
(P38/U L)
(used with Rod Holder)**

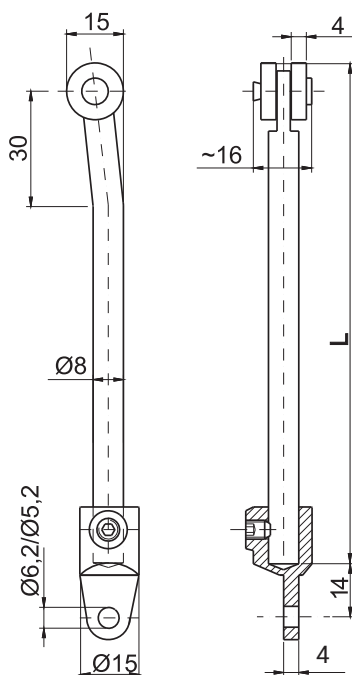

**ROD with Flat End
(P48/U L)
(used with Rod Holder)**

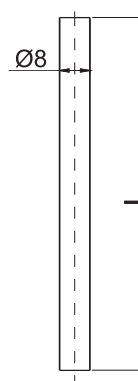

**ROD with Pointed End
(P28/U L)
(used with Rod Holder)**

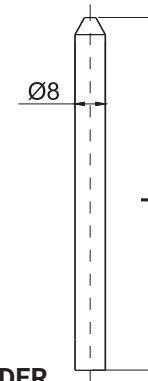

ROD HOLDER

nr 1C.904.051

nr 1C.904.050

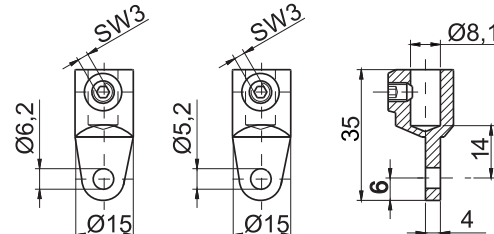

L - length of rod [mm]

CAT. NUMBER	NAME	MATERIAL
P28 L	Rod with pointed end	Steel zinc plated
P38 L	Rod with rollers	Steel zinc plated, rollers-PA6
P48 L	Rod with flat end	Steel zinc plated
P28/U L	Rod with pointed end (adjustable)	Steel zinc plated
P38/U L	Rod with rollers (adjustable)	Steel zinc plated, rollers-PA6
P48/U L	Rod with flat end (adjustable)	Steel zinc plated
1.C.904.051, 1C.904.050	Rod holder	ZAMAK - zinc plated
1C.904.052	Rod holder	Stainless Steel

ROD GUIDE Ø6 - U

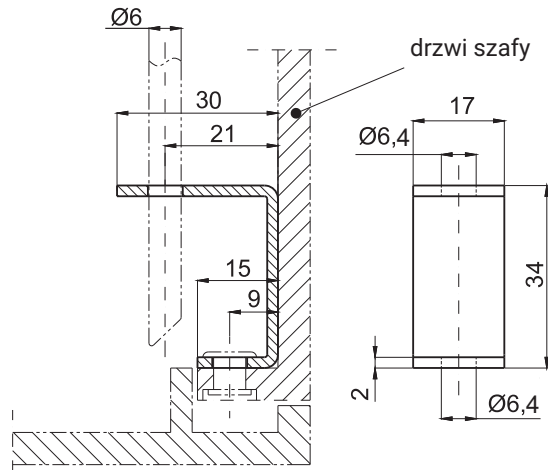

ROD GUIDE Ø6 - L

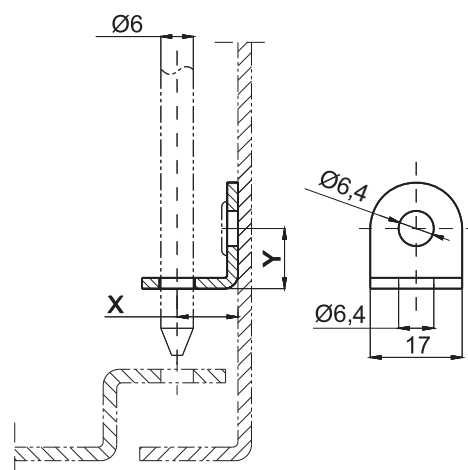

ROD GUIDE Ø8

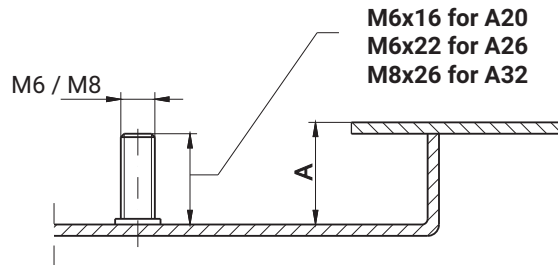
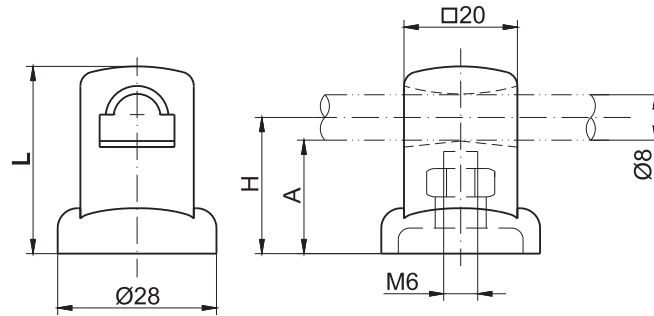

ROD GUIDE RW

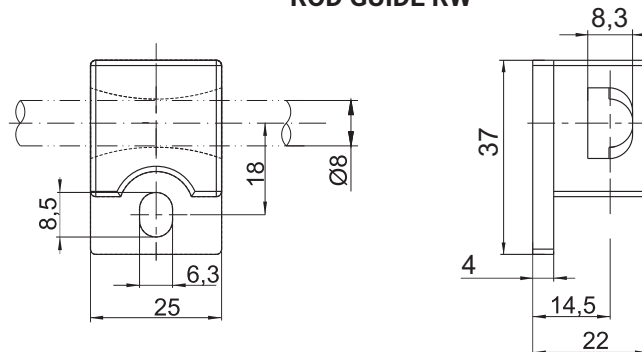

CAT. NUMBER	NAME	DIMENSION Ø8, Ø6 [mm]					MATERIAL
		A	L	H	X	Y	
1C.906.008		20	33	24	-	-	Pa6 colour RAL 9005
1C.906.009	Rod guide Ø8	26	39	30	-	-	
1C.906.010		32	45	36	-	-	
1C.906.002	Rod guide Ø6 L	-	-	-	11,5	8	Steel zinc plated
1C.906.003		-	-	-	22,5	27	
1C.906.001	Rod guide Ø6 U						Steel zinc plated
1C.906.013	Rod guide RW						Pa6 colour RAL 9005

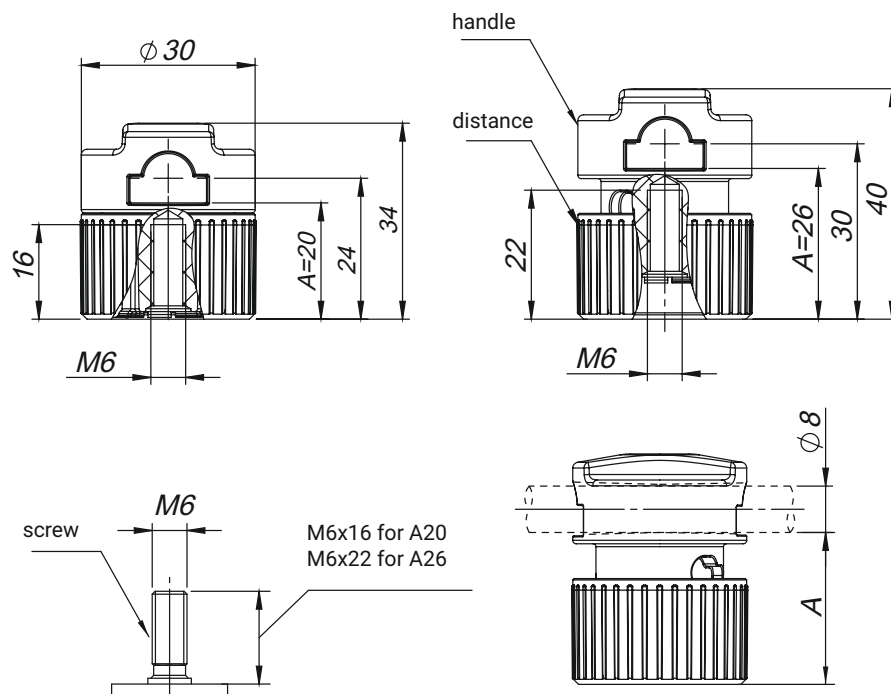

Positions A20 and A26 according to drawing.

To change the position from A20 to A26, rotate the knob in the clockwise or anticlockwise direction relative to the distance until the knob can turn no further.

Change the position of the guide from position A20 to A26 after removing the guide from the rod.

It is possible to use one type of M6x16 stud for both versions of the rod guide.

Tensile Strength [kg]			Tightening Torque
Screw length L	A20	A26	
L=16mm	500	400	to 2Nm
L=22mm	-	500	

CATALOGUE NO.	DETAL	MATERIAL	FINISH [C]
			RAL 9005
1C.906.100	Rod guide $\phi 8$	Polyamide PA GF30	07

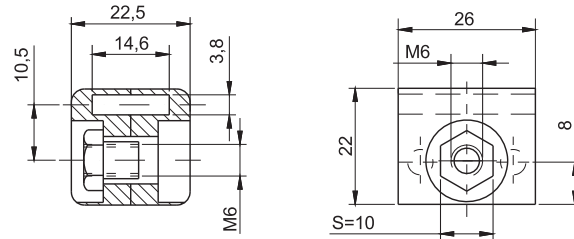

1C.906.012

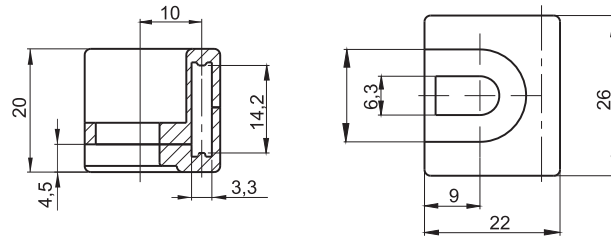

1C.906.014

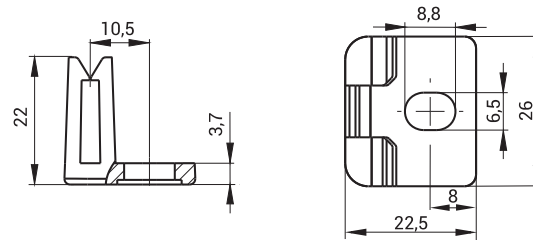

1C.906.015

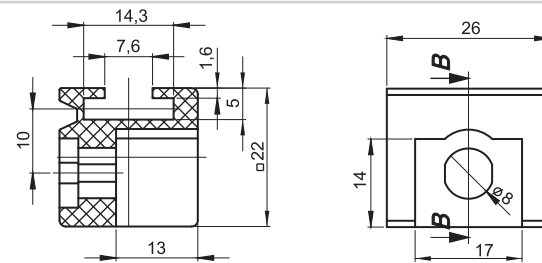

1C.906.018

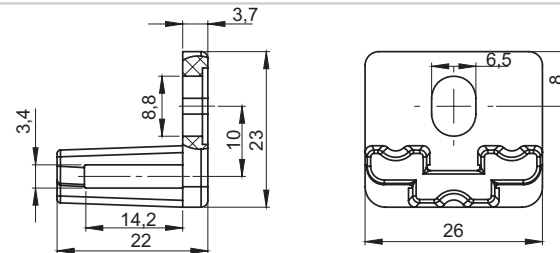

1C.906.019

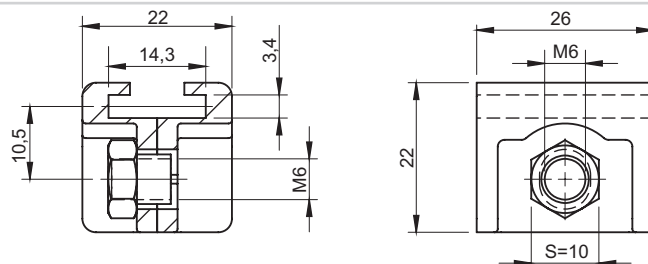

1C.906.020



CAT. NUMBER	NAME	COMPONENTS	MATERIAL
1C.906.012	Rod guide P314	Rod guide P314	PA6 colour RAL 9005
		Nut	Steel zinc plated
1C.906.014	Rod guide P314 ver. 2	Rod guide P314 ver. 2	PA6 colour RAL 9005
1C.906.015	Rod guide P314	Rod guide	PA6 colour RAL 9005
1C.906.018	Rod guide P314 ver. 3	Rod guide P314 ver. 3	PA6 colour RAL 9005
1C.906.019	Rod guide P314	Rod guide	PA6 colour RAL 9005
1C.906.020	Rod guide P314 SN	Rod guide, Nut	Stainless Steel 316

GH - height body
 H - height locking
 h - height cam
 L - length cam
 g - thickness cam

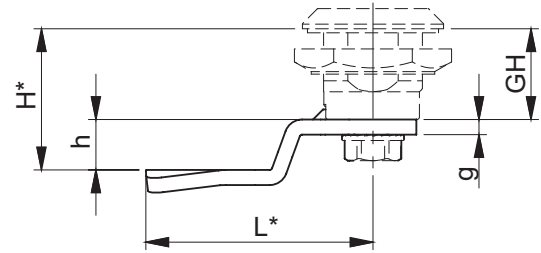

1-point cam with limiter

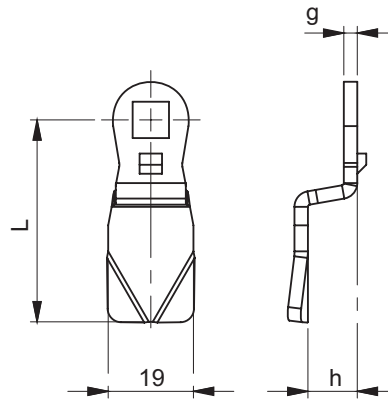
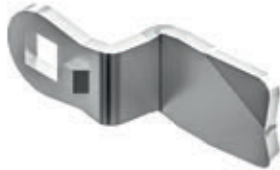

1-point cam without limiter

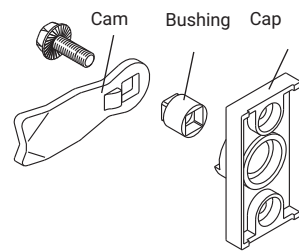
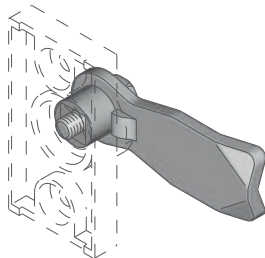
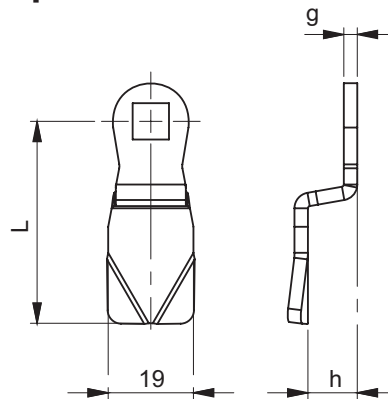

NOTE:
 When ordering 1-point cam with limiter for Cap, you must order bushing, page. 1C-27

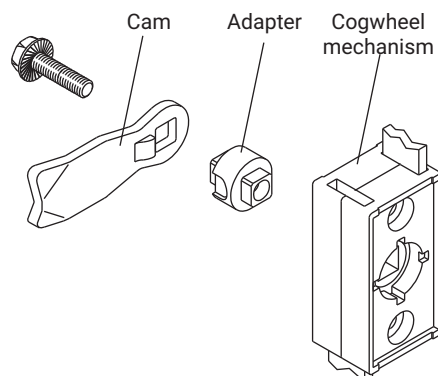
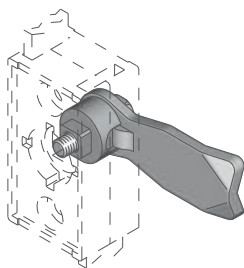

NOTE:
 When ordering 1-point cam with limiter for Cogwheel mechanism, you must also order adapter, page 1C-27

STEEL ZINC PLATED

11	APPLICATION: Locking system with cap and locks M22													
	H	Catalogue number	g*	h	L	GH:18 H	GH:19 H	GH:23 H	GH:28 H	GH:30 H	GH:38 H	GH:40 H	GH:50 H	GH:60 H
CAM RANGE [G]	18	J-1751845	3	0	45	18	19	23	28	30	38	40	50	60
	19	J-1751945	3	1	45	19	20	24	29	31	39	41	51	61
	20	J-1752045	3	2	45	20	21	25	30	32	40	42	52	62
	21	J-1752145	3	3	45	21	22	26	31	33	41	43	53	63
	22	J-1752245	3	4	45	22	23	27	32	34	42	44	54	64
	24	J-1752445	3	6	45	24	25	29	34	36	44	46	56	66
	26	J-1752645	3	8	45	26	27	31	36	38	46	48	58	68
	28	J-1752845	3	10	45	28	29	33	38	40	48	50	60	70
	30	J-1753045	3	12	45	30	31	35	40	42	50	52	62	72
	32	J-1753245	3	14	45	32	33	37	42	44	52	54	64	74
	34	J-1753445	3	16	45	34	35	39	44	46	54	56	66	76
	36	J-1753645	3	18	45	36	37	-	46	48	56	58	68	78
	38	J-1753845	3	20	45	38	39	-	48	50	58	60	70	80
	40	J-1754045	3	22	45	40	41	-	50	52	60	62	72	82
	42	J-1754245	3	24	45	42	43	-	52	54	62	64	74	84
	16	J-1751645	3	-2	45	16	17	-	26	28	36	38	48	58
	14	J-1751445	3	-4	45	14	15	-	24	26	34	36	46	56
	12	J-1751245	3	-6	45	12	13	-	22	24	32	34	44	54
	10	J-1751045	3	-8	45	10	11	-	20	22	30	32	42	52
	8	J-1750845	3	-10	45	8	9	-	28	20	28	30	40	50

12	APPLICATION: Locks M22													
	H	Catalogue number	g*	h	L	GH:18 H	GH:19 H	GH:23 H	GH:28 H	GH:30 H	GH:38 H	GH:40 H	GH:50 H	GH:60 H
CAM RANGE [G]	18	J-1601845	3	0	45	18	19	23	28	30	38	40	50	60
	19	J-1601945	3	1	45	19	20	24	29	31	39	41	51	61
	20	J-1602045	3	2	45	20	21	25	30	32	40	42	52	62
	21	J-1602145	3	3	45	21	22	26	31	33	41	43	53	63
	22	J-1602245	3	4	45	22	23	27	32	34	42	44	54	64
	24	J-1602445	3	6	45	24	25	29	34	36	44	46	56	66
	26	J-1602645	3	8	45	26	27	31	36	38	46	48	58	68
	28	J-1602845	3	10	45	28	29	33	38	40	48	50	60	70
	30	J-1603045	3	12	45	30	31	35	40	42	50	52	62	72
	32	J-1603245	3	14	45	32	33	37	42	44	52	54	64	74
	34	J-1603445	3	16	45	34	35	39	44	46	54	56	66	76
	36	J-1603645	3	18	45	36	37	-	46	48	56	58	68	78
	38	J-1603845	3	20	45	38	39	-	48	50	58	60	70	80
	40	J-1604045	3	22	45	40	41	-	50	52	60	62	72	82
	42	J-1604245	3	24	45	42	43	-	52	54	62	64	74	84
	16	J-1601645	3	-2	45	16	17	-	26	28	36	38	48	58
	14	J-1601445	3	-4	45	14	15	-	24	26	34	36	46	56
	12	J-1601245	3	-6	45	12	13	-	22	24	32	34	44	54
	10	J-1601045	3	-8	45	10	11	-	20	22	30	32	42	52
	8	J-1600845	3	-10	45	8	9	-	28	20	28	30	40	50

When ordering a custom cam, you should contact your dealer for more details.

STAINLESS STEEL

13	APPLICATION: Locking system with cap and locksM22													
	H	Numer katalogowy	g*	h	L	GH:18 H	GH:19 H	GH:23 H	GH:28 H	GH:30 H	GH:38 H	GH:40 H	GH:50 H	GH:60 H
CAM RANGE [G]	18	J-1751845SN	3	0	45	18	19	23	28	30	38	40	50	60
	19	J-1751945SN	3	1	45	19	20	24	29	31	39	41	51	61
	20	J-1752045SN	3	2	45	20	21	25	30	32	40	42	52	62
	21	J-1752145SN	3	3	45	21	22	26	31	33	41	43	53	63
	22	J-1752245SN	3	4	45	22	23	27	32	34	42	44	54	64
	24	J-1752445SN	3	6	45	24	25	29	34	36	44	46	56	66
	26	J-1752645SN	3	8	45	26	27	31	36	38	46	48	58	68
	28	J-1752845SN	3	10	45	28	29	33	38	40	48	50	60	70
	30	J-1753045SN	3	12	45	30	31	35	40	42	50	52	62	72
	32	J-1753245SN	3	14	45	32	33	37	42	44	52	54	64	74
	34	J-1753445SN	3	16	45	34	35	39	44	46	54	56	66	76
	36	J-1753645SN	3	18	45	36	37	-	46	48	56	58	68	78
	38	J-1753845SN	3	20	45	38	39	-	48	50	58	60	70	80
	40	J-1754045SN	3	22	45	40	41	-	50	52	60	62	72	82
	42	J-1754245SN	3	24	45	42	43	-	52	54	62	64	74	84
	16	J-1751645SN	3	-2	45	16	17	-	26	28	36	38	48	58
	14	J-1751445SN	3	-4	45	14	15	-	24	26	34	36	46	56
	12	J-1751245SN	3	-6	45	12	13	-	22	24	32	34	44	54
	10	J-1751045SN	3	-8	45	10	11	-	20	22	30	32	42	52
	8	J-175845SN	3	-10	45	8	9	-	28	20	28	30	40	50

14	APPLICATION: Locks M22													
	H	Numer katalogowy	g*	h	L	GH:18 H	GH:19 H	GH:23 H	GH:28 H	GH:30 H	GH:38 H	GH:40 H	GH:50 H	GH:60 H
CAM RANGE [G]	18	J-1601845SN	3	0	45	18	19	23	28	30	38	40	50	60
	19	J-1601945SN	3	1	45	19	20	24	29	31	39	41	51	61
	20	J-1602045SN	3	2	45	20	21	25	30	32	40	42	52	62
	21	J-1602145SN	3	3	45	21	22	26	31	33	41	43	53	63
	22	J-1602245SN	3	4	45	22	23	27	32	34	42	44	54	64
	24	J-1602445SN	3	6	45	24	25	29	34	36	44	46	56	66
	26	J-1602645SN	3	8	45	26	27	31	36	38	46	48	58	68
	28	J-1602845SN	3	10	45	28	29	33	38	40	48	50	60	70
	30	J-1603045SN	3	12	45	30	31	35	40	42	50	52	62	72
	32	J-1603245SN	3	14	45	32	33	37	42	44	52	54	64	74
	34	J-1603445SN	3	16	45	34	35	39	44	46	54	56	66	76
	36	J-1603645SN	3	18	45	36	37	-	46	48	56	58	68	78
	38	J-1603845SN	3	20	45	38	39	-	48	50	58	60	70	80
	40	J-1604045SN	3	22	45	40	41	-	50	52	60	62	72	82
	42	J-1604245SN	3	24	45	42	43	-	52	54	62	64	74	84
	16	J-1601645SN	3	-2	45	16	17	-	26	28	36	38	48	58
	14	J-1601445SN	3	-4	45	14	15	-	24	26	34	36	46	56
	12	J-1601245SN	3	-6	45	12	13	-	22	24	32	34	44	54
	10	J-1601045SN	3	-8	45	10	11	-	20	22	30	32	42	52
	8	J-160845SN	3	-10	45	8	9	-	28	20	28	30	40	50

When ordering a custom cam, you should contact your dealer for more details.

STEEL ZINC PLATED

15	H	Cat. Number	g*	h	L	GH:18 H	GH:22 H	GH:30 H	GH:40 H	GH:50 H	GH:60 H
	CAM RANGE [G]	18	J-1001845	3	0	45	18	22	30	40	50
19		J-1001945	3	1	45	19	23	31	41	51	61
20		J-1002045	3	2	45	20	24	32	42	52	62
21		J-1002145	3	3	45	21	25	33	43	53	63
22		J-1002245	3	4	45	22	26	34	44	54	64
24		J-1002445	3	6	45	24	28	36	46	56	66
26		J-1002645	3	8	45	26	30	38	48	58	68
28		J-1002845	3	10	45	28	32	40	50	60	70
30		J-1003045	3	12	45	30	34	42	52	62	72
32		J-1003245	3	14	45	32	36	44	54	64	74
34		J-1003445	3	16	45	34	38	46	56	66	76
36		J-1003645	3	18	45	36	40	48	58	68	78
38		J-1003845	3	20	45	38	42	50	60	70	80
40		J-1004045	3	22	45	40	44	52	62	72	82
42		J-1004245	3	24	45	42	46	54	64	74	84
16		J-1001645	3	-2	45	16	20	28	38	48	58
14		J-1001445	3	-4	45	14	18	26	36	46	56
12		J-1001245	3	-6	45	12	16	24	34	44	54
10		J-1001045	3	-8	45	10	14	22	32	42	52
8		J-100845	3	-10	45	8	12	20	30	40	50
6	J-100645	3	-12	45	6	10	18	28	38	48	
4	J-100445	3	-14	45	4	8	16	26	36	46	

STAINLESS STEEL

16	H	Cat. Number	g*	h	L	GH:18 H	GH:22 H	GH:30 H	GH:40 H	GH:50 H	GH:60 H
	CAM RANGE [G]	18	J-1001845SN	3	0	45	18	22	30	40	50
19		J-1001945SN	3	1	45	19	23	31	41	51	61
20		J-1002045SN	3	2	45	20	24	32	42	52	62
21		J-1002145SN	3	3	45	21	25	33	43	53	63
22		J-1002245SN	3	4	45	22	26	34	44	54	64
24		J-1002445SN	3	6	45	24	28	36	46	56	66
26		J-1002645SN	3	8	45	26	30	38	48	58	68
28		J-1002845SN	3	10	45	28	32	40	50	60	70
30		J-1003045SN	3	12	45	30	34	42	52	62	72
32		J-1003245SN	3	14	45	32	36	44	54	64	74
34		J-1003445SN	3	16	45	34	38	46	56	66	76
36		J-1003645SN	3	18	45	36	40	48	58	68	78
38		J-1003845SN	3	20	45	38	42	50	60	70	80
40		J-1004045SN	3	22	45	40	44	52	62	72	82
42		J-1004245SN	3	24	45	42	46	54	64	74	84
16		J-1001645SN	3	-2	45	16	20	28	38	48	58
14		J-1001445SN	3	-4	45	14	18	26	36	46	56
12		J-1001245SN	3	-6	45	12	16	24	34	44	54
10		J-1001045SN	3	-8	45	10	14	22	32	42	52
8		J-100845SN	3	-10	45	8	12	20	30	40	50
6	J-100645SN	3	-12	45	6	10	18	28	38	48	
4	J-100445SN	3	-14	45	4	8	16	26	36	46	

STEEL ZINC PLATED

17	APPLICATION: Locking system with cap and locks M22													
	H	Catalogue number	g*	h	L	GH:18 H	GH:19 H	GH:23 H	GH:28 H	GH:30 H	GH:38 H	GH:40 H	GH:50 H	GH:60 H
CAM RANGE [G]	18	J-1651845	3	0	45	18	19	23	28	30	38	40	50	60
	19	J-1651945	3	1	45	19	20	24	29	31	39	41	51	61
	20	J-1652045	3	2	45	20	21	25	30	32	40	42	52	62
	21	J-1652145	3	3	45	21	22	26	31	33	41	43	53	63
	22	J-1652245	3	4	45	22	23	27	32	34	42	44	54	64
	24	J-1652445	3	6	45	24	25	29	34	36	44	46	56	66
	26	J-1652645	3	8	45	26	27	31	36	38	46	48	58	68
	28	J-1652845	3	10	45	28	29	33	38	40	48	50	60	70
	30	J-1653045	3	12	45	30	31	35	40	42	50	52	62	72
	32	J-1653245	3	14	45	32	33	37	42	44	52	54	64	74
	34	J-1653445	3	16	45	34	35	39	44	46	54	56	66	76
	36	J-1653645	3	18	45	36	37	-	46	48	56	58	68	78
	38	J-1653845	3	20	45	38	39	-	48	50	58	60	70	80
	40	J-1654045	3	22	45	40	41	-	50	52	60	62	72	82
	42	J-1654245	3	24	45	42	43	-	52	54	62	64	74	84
	16	J-1651645	3	-2	45	16	17	-	26	28	36	38	48	58
	14	J-1651445	3	-4	45	14	15	-	24	26	34	36	46	56
	12	J-1651245	3	-6	45	12	13	-	22	24	32	34	44	54
	10	J-1651045	3	-8	45	10	11	-	20	22	30	32	42	52
	8	J-1650845	3	-10	45	8	9	-	28	20	28	30	40	50

STAINLESS STEEL

17A	APPLICATION: Locks M22													
	H	Catalogue number	g*	h	L	GH:18 H	GH:19 H	GH:23 H	GH:28 H	GH:30 H	GH:38 H	GH:40 H	GH:50 H	GH:60 H
CAM RANGE [G]	18	J-1651845SN	3	0	45	18	19	23	28	30	38	40	50	60
	19	J-1651945SN	3	1	45	19	20	24	29	31	39	41	51	61
	20	J-1652045SN	3	2	45	20	21	25	30	32	40	42	52	62
	21	J-1652145SN	3	3	45	21	22	26	31	33	41	43	53	63
	22	J-1652245SN	3	4	45	22	23	27	32	34	42	44	54	64
	24	J-1652445SN	3	6	45	24	25	29	34	36	44	46	56	66
	26	J-1652645SN	3	8	45	26	27	31	36	38	46	48	58	68
	28	J-1652845SN	3	10	45	28	29	33	38	40	48	50	60	70
	30	J-1653045SN	3	12	45	30	31	35	40	42	50	52	62	72
	32	J-1653245SN	3	14	45	32	33	37	42	44	52	54	64	74
	34	J-1653445SN	3	16	45	34	35	39	44	46	54	56	66	76
	36	J-1653645SN	3	18	45	36	37	-	46	48	56	58	68	78
	38	J-1653845SN	3	20	45	38	39	-	48	50	58	60	70	80
	40	J-1654045SN	3	22	45	40	41	-	50	52	60	62	72	82
	42	J-1654245SN	3	24	45	42	43	-	52	54	62	64	74	84
	16	J-1651645SN	3	-2	45	16	17	-	26	28	36	38	48	58
	14	J-1651445SN	3	-4	45	14	15	-	24	26	34	36	46	56
	12	J-1651245SN	3	-6	45	12	13	-	22	24	32	34	44	54
	10	J-1651045SN	3	-8	45	10	11	-	20	22	30	32	42	52
	8	J-1650845SN	3	-10	45	8	9	-	28	20	28	30	40	50

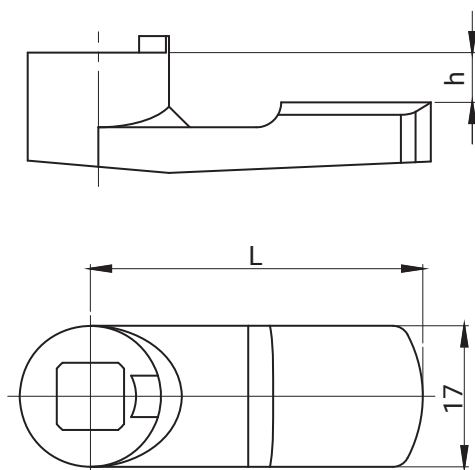

18		CAM WITH LIMITER							
CAM RANGE [G]	H	Cat. Number	h	L	GH:18 H	GH:30 H	GH:40 H	GH:50 H	GH:60 H
	18P	JP2-10018	0	40	18	30	40	50	60
	21P	JP2-10021	3	40	21	33	43	53	63
	24P	JP2-10024	6	40	24	36	46	56	66

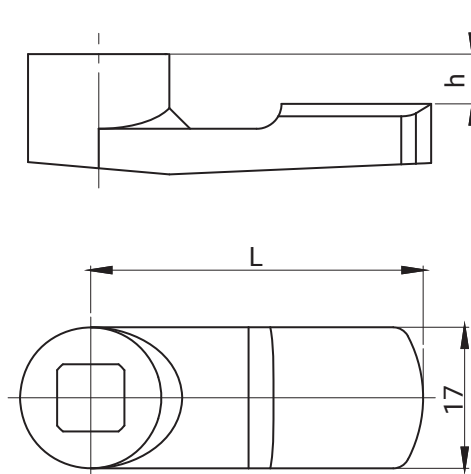

19		CAM WITHOUT LIMITER							
CAM RANGE [G]	H	Cat. Number	h	L	GH:18 H	GH:30 H	GH:40 H	GH:50 H	GH:60 H
	18P	JP-10018	0	40	18	30	40	50	60
	21P	JP-10021	3	40	21	33	43	53	63
	24P	JP-10024	6	40	24	36	46	56	66
	29P	JP-10029	11	40	29	41	51	61	71

stainless steel

3-point CAM
(without limiter
with *protective element*)

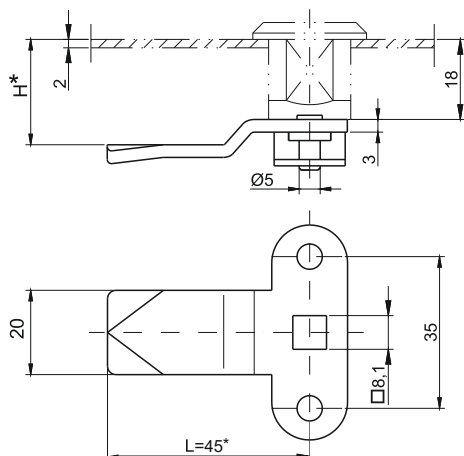

2-point CAM
(with *protective element*)

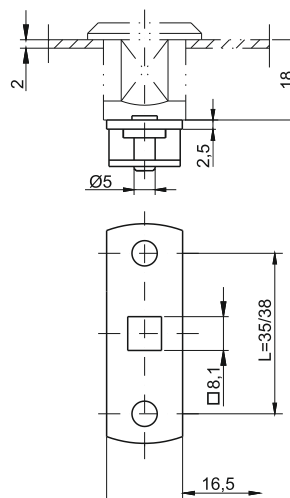

2-point CAM
(with *Cir Clips ver. 1, ver. 2, ver. 3*)

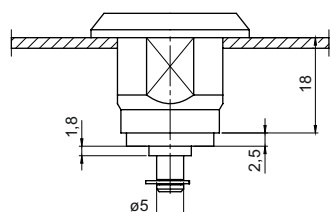

ver. 1

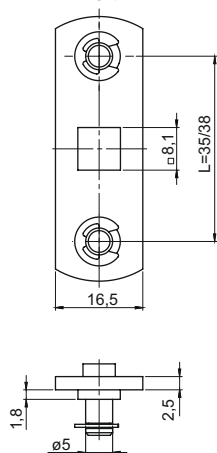

ver. 2

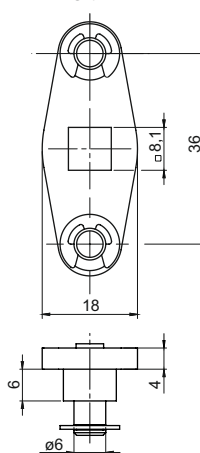

ver. 3

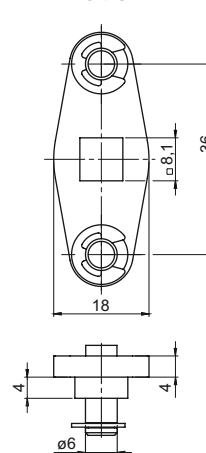

21

CAM RANGE [G]

CAT. NUMBER		NAME	DIMENSIONS H [mm]	MATERIAL
STEEL ZINC PLATED	STAINLESS STEEL			
JB-30018	JB-30018SN	3-point Cam without limiter with protective element	18	Steel zinc plated or stainless steel
JB-30021	JB-30021SN		21	
JB-30024	JB-30024SN		24	
JB-30029	JB-30029SN		29	
JB-20018/35	JB-20018/35SN	2-point Cam with protective element	18L=35	Steel zinc plated or stainless steel
JB-20018/38	JB-20018/38SN		18L=38	
J-20018/35	J-20018/35SN	2-point Cam with Cir Clips ver. 1	18L=35	Steel zinc plated or stainless steel
J-20018/38	J-20018/38SN		18L=38	
J-20018/36	J-20018/36SN	2-point Cam with Cir Clips ver. 2	18L=36	Steel zinc plated
JA-20018/36	JA-20018/36SN	2-point Cam with Cir Clips ver. 3	18L=36	or stainless steel

• *dimension negotiable

NOTE: When ordering 2-point Cams with dimension between pins 35 mm you must add /35 e.g. (JB-20018/35 or J-20018/35).

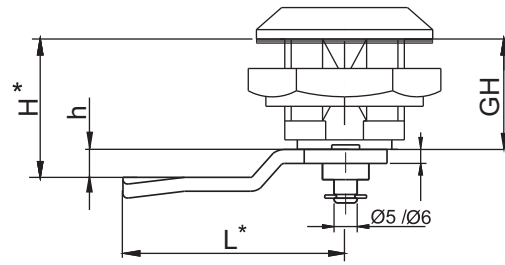

- GH - height body
- H - height locking
- h - height cam
- L - lenght cam
- g - thickness cam

3-point CAM with limiter

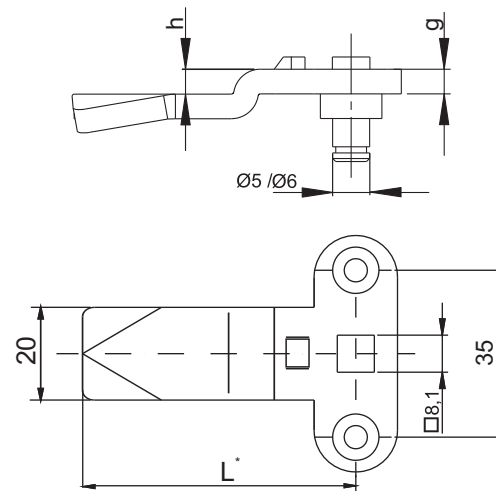

3-point CAM without limiter

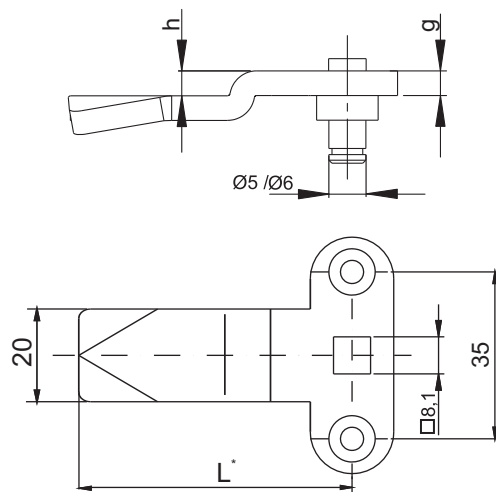

STEEL ZINC PLATED

31	APPLICATION: Locking system with cap and locks M22													
	H	Numer katalogowy	g*	h	L	GH:18 H	GH:19 H	GH:23 H	GH:28 H	GH:30 H	GH:38 H	GH:40 H	GH:50 H	GH:60 H
CAM RANGE [G]	18	J-3751845	3	0	45	18	19	23	28	30	38	40	50	60
	19	J-3751945	3	1	45	19	20	24	29	31	39	41	51	61
	20	J-3752045	3	2	45	20	21	25	30	32	40	42	52	62
	21	J-3752145	3	3	45	21	22	26	31	33	41	43	53	63
	22	J-3752245	3	4	45	22	23	27	32	34	42	44	54	64
	24	J-3752445	3	6	45	24	25	29	34	36	44	46	56	66
	26	J-3752645	3	8	45	26	27	31	36	38	46	48	58	68
	28	J-3752845	3	10	45	28	29	33	38	40	48	50	60	70
	30	J-3753045	3	12	45	30	31	35	40	42	50	52	62	72
	32	J-3753245	3	14	45	32	33	37	42	44	52	54	64	74
	34	J-3753445	3	16	45	34	35	39	44	46	54	56	66	76
	36	J-3753645	3	18	45	36	37	-	46	48	56	58	68	78
	38	J-3753845	3	20	45	38	39	-	48	50	58	60	70	80
	40	J-3754045	3	22	45	40	41	-	50	52	60	62	72	82
	42	J-3754245	3	24	45	42	43	-	52	54	62	64	74	84
	16	J-3751645	3	-2	45	16	17	-	26	28	36	38	48	58
	14	J-3751445	3	-4	45	14	15	-	24	26	34	36	46	56
	12	J-3751245	3	-6	45	12	13	-	22	24	32	34	44	54
10	J-3751045	3	-8	45	10	11	-	20	22	30	32	42	52	

32	APPLICATION: Locks M22													
	H	Numer katalogowy	g*	h	L	GH:18 H	GH:19 H	GH:23 H	GH:28 H	GH:30 H	GH:38 H	GH:40 H	GH:50 H	GH:60 H
CAM RANGE [G]	18	J-3601845	3	0	45	18	19	23	28	30	38	40	50	60
	19	J-3601945	3	1	45	19	20	24	29	31	39	41	51	61
	20	J-3602045	3	2	45	20	21	25	30	32	40	42	52	62
	21	J-3602145	3	3	45	21	22	26	31	33	41	43	53	63
	22	J-3602245	3	4	45	22	23	27	32	34	42	44	54	64
	24	J-3602445	3	6	45	24	25	29	34	36	44	46	56	66
	26	J-3602645	3	8	45	26	27	31	36	38	46	48	58	68
	28	J-3602845	3	10	45	28	29	33	38	40	48	50	60	70
	30	J-3603045	3	12	45	30	31	35	40	42	50	52	62	72
	32	J-3603245	3	14	45	32	33	37	42	44	52	54	64	74
	34	J-3603445	3	16	45	34	35	39	44	46	54	56	66	76
	36	J-3603645	3	18	45	36	37	-	46	48	56	58	68	78
	38	J-3603845	3	20	45	38	39	-	48	50	58	60	70	80
	40	J-3604045	3	22	45	40	41	-	50	52	60	62	72	82
	42	J-3604245	3	24	45	42	43	-	52	54	62	64	74	84
	16	J-3601645	3	-2	45	16	17	-	26	28	36	38	48	58
	14	J-3601445	3	-4	45	14	15	-	24	26	34	36	46	56
	12	J-3601245	3	-6	45	12	13	-	22	24	32	34	44	54
10	J-3601045	3	-8	45	10	11	-	20	22	30	32	42	52	

When ordering a custom cam, you should contact your dealer for more details ..

STAINLESS STEEL

33	APPLICATION: Locking system with cap and locks M22													
	H	Catalogue number	g*	h	L	GH:18 H	GH:19 H	GH:23 H	GH:28 H	GH:30 H	GH:38 H	GH:40 H	GH:50 H	GH:60 H
CAM RANGE [G]	18	J-3751845SN	3	0	45	18	19	23	28	30	38	40	50	60
	19	J-3751945SN	3	1	45	19	20	24	29	31	39	41	51	61
	20	J-3752045SN	3	2	45	20	21	25	30	32	40	42	52	62
	21	J-3752145SN	3	3	45	21	22	26	31	33	41	43	53	63
	22	J-3752245SN	3	4	45	22	23	27	32	34	42	44	54	64
	24	J-3752445SN	3	6	45	24	25	29	34	36	44	46	56	66
	26	J-3752645SN	3	8	45	26	27	31	36	38	46	48	58	68
	28	J-3752845SN	3	10	45	28	29	33	38	40	48	50	60	70
	30	J-3753045SN	3	12	45	30	31	35	40	42	50	52	62	72
	32	J-3753245SN	3	14	45	32	33	37	42	44	52	54	64	74
	34	J-3753445SN	3	16	45	34	35	39	44	46	54	56	66	76
	36	J-3753645SN	3	18	45	36	37	-	46	48	56	58	68	78
	38	J-3753845SN	3	20	45	38	39	-	48	50	58	60	70	80
	40	J-3754045SN	3	22	45	40	41	-	50	52	60	62	72	82
	42	J-3754245SN	3	24	45	42	43	-	52	54	62	64	74	84
	16	J-3751645SN	3	-2	45	16	17	-	26	28	36	38	48	58
	14	J-3751445SN	3	-4	45	14	15	-	24	26	34	36	46	56
	12	J-3751245SN	3	-6	45	12	13	-	22	24	32	34	44	54
	10	J-3751045SN	3	-8	45	10	11	-	20	22	30	32	42	52
	8	J-375845SN	3	-10	45	8	9	-	28	20	28	30	40	50

34	APPLICATION: Locks M22													
	H	Catalogue number	g*	h	L	GH:18 H	GH:19 H	GH:23 H	GH:28 H	GH:30 H	GH:38 H	GH:40 H	GH:50 H	GH:60 H
CAM RANGE [G]	18	J-3601845SN	3	0	45	18	19	23	28	30	38	40	50	60
	19	J-3601945SN	3	1	45	19	20	24	29	31	39	41	51	61
	20	J-3602045SN	3	2	45	20	21	25	30	32	40	42	52	62
	21	J-3602145SN	3	3	45	21	22	26	31	33	41	43	53	63
	22	J-3602245SN	3	4	45	22	23	27	32	34	42	44	54	64
	24	J-3602445SN	3	6	45	24	25	29	34	36	44	46	56	66
	26	J-3602645SN	3	8	45	26	27	31	36	38	46	48	58	68
	28	J-3602845SN	3	10	45	28	29	33	38	40	48	50	60	70
	30	J-3603045SN	3	12	45	30	31	35	40	42	50	52	62	72
	32	J-3603245SN	3	14	45	32	33	37	42	44	52	54	64	74
	34	J-3603445SN	3	16	45	34	35	39	44	46	54	56	66	76
	36	J-3603645SN	3	18	45	36	37	-	46	48	56	58	68	78
	38	J-3603845SN	3	20	45	38	39	-	48	50	58	60	70	80
	40	J-3604045SN	3	22	45	40	41	-	50	52	60	62	72	82
	42	J-3604245SN	3	24	45	42	43	-	52	54	62	64	74	84
	16	J-3601645SN	3	-2	45	16	17	-	26	28	36	38	48	58
	14	J-3601445SN	3	-4	45	14	15	-	24	26	34	36	46	56
	12	J-3601245SN	3	-6	45	12	13	-	22	24	32	34	44	54
	10	J-3601045SN	3	-8	45	10	11	-	20	22	30	32	42	52
	8	J-360845SN	3	-10	45	8	9	-	28	20	28	30	40	50

When ordering a custom cam, you should contact your dealer for more details ..

STAINLESS STEEL

35	H	Cat. Number	g*	h	L	GH:18	GH:22	GH:30	GH:40	GH:50	GH:60
						H	H	H	H	H	H
CAM RANGE [G]	18	J-3001845	3	0	45	18	22	30	40	50	60
	19	J-3001945	3	1	45	19	23	31	41	51	61
	20	J-3002045	3	2	45	20	24	32	42	52	62
	21	J-3002145	3	3	45	21	25	33	43	53	63
	22	J-3002245	3	4	45	22	26	34	44	54	64
	24	J-3002445	3	6	45	24	28	36	46	56	66
	26	J-3002645	3	8	45	26	30	38	48	58	68
	28	J-3002845	3	10	45	28	32	40	50	60	70
	30	J-3003045	3	12	45	30	34	42	52	62	72
	32	J-3003245	3	14	45	32	36	44	54	64	74
	34	J-3003445	3	16	45	34	38	46	56	66	76
	36	J-3003645	3	18	45	36	40	48	58	68	78
	38	J-3003845	3	20	45	38	42	50	60	70	80
	40	J-3004045	3	22	45	40	44	52	62	72	82
	42	J-3004245	3	24	45	42	46	54	64	74	84
	16	J-3001645	3	-2	45	16	20	28	38	48	58
	14	J-3001445	3	-4	45	14	18	26	36	46	56
	12	J-3001245	3	-6	45	12	16	24	34	44	54
	10	J-3001045	3	-8	45	10	14	22	32	42	52
	8	J-3000845	3	-10	45	8	12	20	30	40	50

STAINLESS STEEL

36	H	Cat. Number	g*	h	L	GH:18	GH:22	GH:30	GH:40	GH:50	GH:60
						H	H	H	H	H	H
CAM RANGE [G]	18	J-3001845SN	3	0	45	18	22	30	40	50	60
	19	J-3001945SN	3	1	45	19	23	31	41	51	61
	20	J-3002045SN	3	2	45	20	24	32	42	52	62
	21	J-3002145SN	3	3	45	21	25	33	43	53	63
	22	J-3002245SN	3	4	45	22	26	34	44	54	64
	24	J-3002445SN	3	6	45	24	28	36	46	56	66
	26	J-3002645SN	3	8	45	26	30	38	48	58	68
	28	J-3002845SN	3	10	45	28	32	40	50	60	70
	30	J-3003045SN	3	12	45	30	34	42	52	62	72
	32	J-3003245SN	3	14	45	32	36	44	54	64	74
	34	J-3003445SN	3	16	45	34	38	46	56	66	76
	36	J-3003645SN	3	18	45	36	40	48	58	68	78
	38	J-3003845SN	3	20	45	38	42	50	60	70	80
	40	J-3004045SN	3	22	45	40	44	52	62	72	82
	42	J-3004245SN	3	24	45	42	46	54	64	74	84
	16	J-3001645SN	3	-2	45	16	20	28	38	48	58
	14	J-3001445SN	3	-4	45	14	18	26	36	46	56
	12	J-3001245SN	3	-6	45	12	16	24	34	44	54
	10	J-3001045SN	3	-8	45	10	14	22	32	42	52
	8	J-3000845SN	3	-10	45	8	12	20	30	40	50

1-point hook cam TYPE JK

JK1-10018-G-M

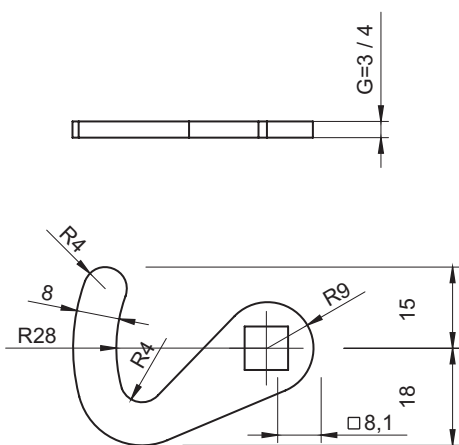

JK2-10018-G-M

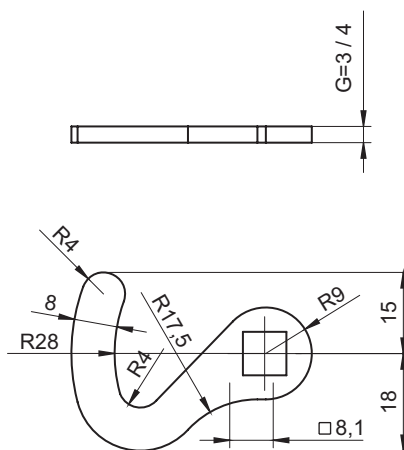

JK1-16018-G-L-M

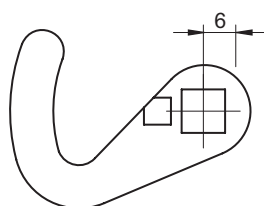

JK2-16018-G-P-M

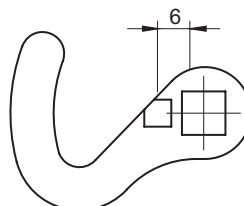
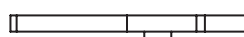

JK1 Left



JK1 Right

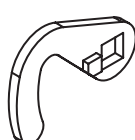

JK2 Left



JK2 Right

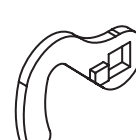

CAT. NUMBER		DESCRIPTION	MATERIAL
JK1-10018-G-M	JK2-10018-G-M	Cam no limiter	ST - steel zinc plated SN - stainless steel
JK1-16018-G-L-M	JK2-16018-G-L-M	Left cam with limiter	
JK1-16018-G-P-M	JK2-16018-G-P-M	Right cam with limiter	

How to order :

Catalogue no.

Thickness cam G=3, 4

Closing direction L-left, P-right
(Only for cam with limiter)

Material version (ST, SN)

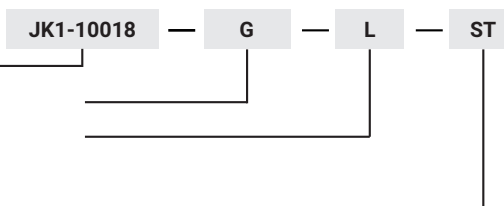



**1-point cam without limiter
TYP J-6000**

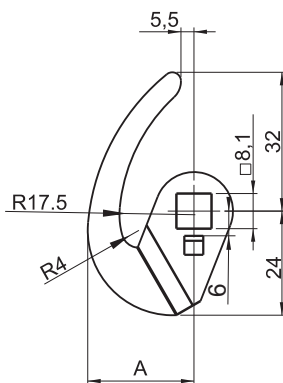

**1-point cam with limiter
TYP J-6000**

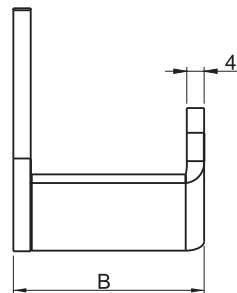

**1-point cam stepped
TYP JK-1610.01.**

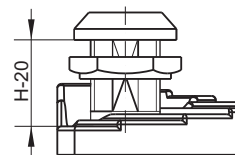
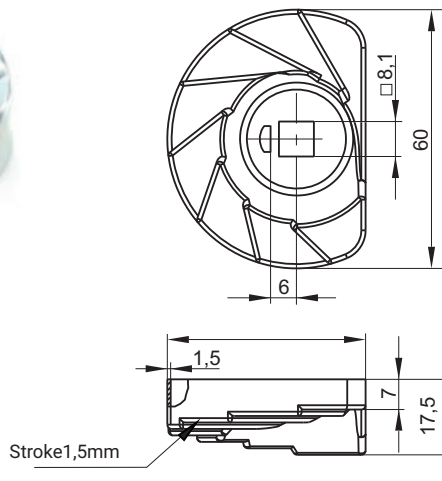

Dimension H 18mm: 20, 18.5, 17, 15.5, 14, 12.5, 11, 9.5
Cam works with housing 18, 30, 60

CAT. NUMBER		NAME	DIMENSION [mm]		
STEEL	STAINLESS STEEL		h	A	B
J-6000.01	J-6000.01SN	1-point cam hook without limiter	22	26	26
J-6000.02	J-6000.02SN		40	24,5	44
J-6000.03	J-6000.03SN	1-point cam hook with limiter	22	26	26
J-6000.04	J-6000.04SN		40	24,5	44
JK-1610.01		1-point cam stepped			

• **dimensions negotiable*



3-point CAM.
(with limiter and protective element for Cap)

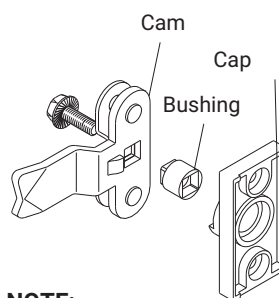
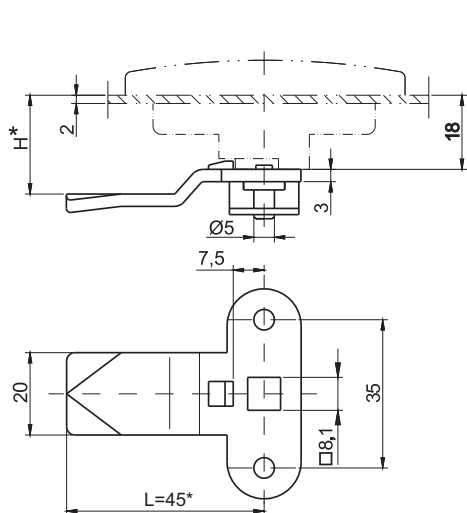

NOTE:
When ordering 3-point cam with limiter for cap, you must order bushing, page 1C-27.

3-point CAM.
(with limiter and protective element)

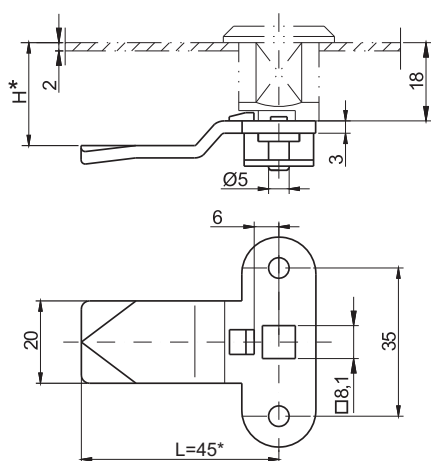

3-point CAM.
(with limiter)

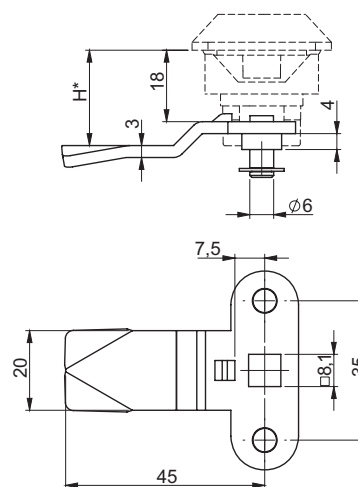

38	CAT. NUMBER		NAME	DIMENSION H [mm]	MATERIAL
	SEEL ZINC PLATED	STAINLESS STEEL			
CAM RANGE [G]	JBN-37518	JBN-37518SN	3-point cam with limiter and protective element used with cap, page 1C-9	18	Steel zinc plated or Stainless Steel
	JBN-37521	JBN-37521SN		21	
	JBN-37524	JBN-37524SN		24	
	JBN-37529	JBN-37529SN		29	
	JB-37518	JB-37518SN	3-point cam with limiter and protective element	18	Steel zinc plated or Stainless Steel
	JB-37521	JB-37521SN		21	
	JB-37524	JB-37524SN		24	
	JB-37529	JB-37529SN		29	
	JA-3751845	JB-3751845SN	3-point cam with limiter	18	Steel zinc plated or Stainless Steel
	JA-3752145	JB-3752145SN		21	
	JA-3752445	JB-3752445SN		24	
	JA-3752945	JB-3752945SN		29	

• *dimension negotiable - extra charge

1-point CAM JZ (without limiter)

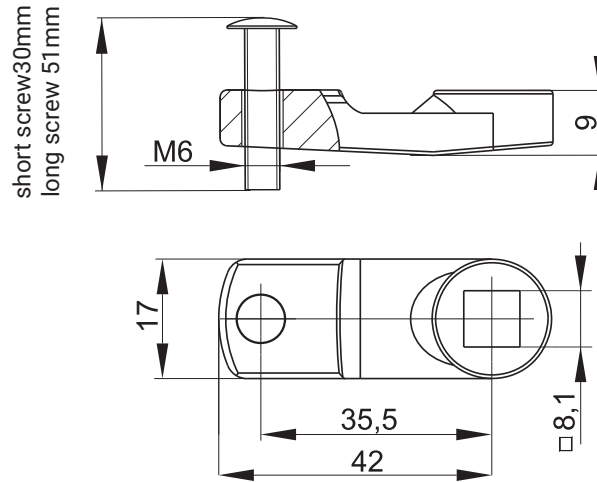

1-point CAM JZ (with limiter)

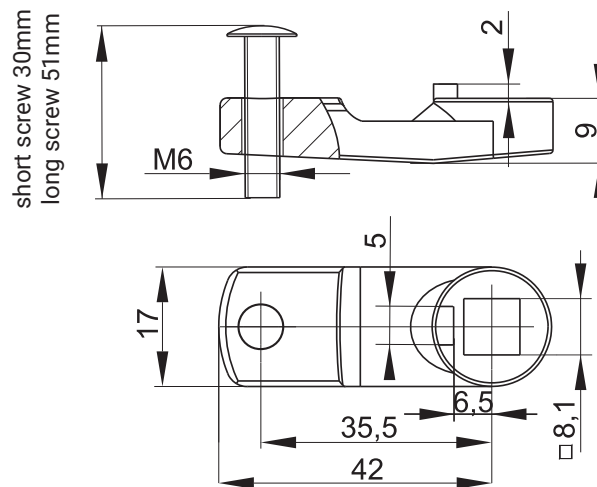

CAT. NUMBER	NAME	MATERIAL
JZ-001	1-point CAM JZ without limited	Zamak - RAL 9005, zinc plated, chrome
JZ-002	1-point CAM JZ with limited	Zamak - RAL 9005, zinc plated, chrome

Cam adapter JC-20018/36 Cam ZAMAK JZN-10027/30

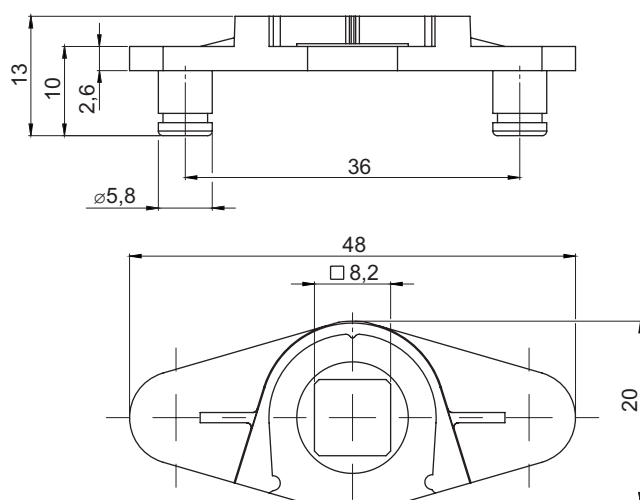

CATALOGUE NO.	DETAIL	MATERIAL
JC-20018/36	Cam adapter	ZAMAK, zinc plated

Cam adapter JC-20018/36 is fitted with the rod 1C.904.051.
and group of cams 1-point no. 11, 12, 13, 14, 15, 16 i 17 (pg. 1C-10 - 1C-13)

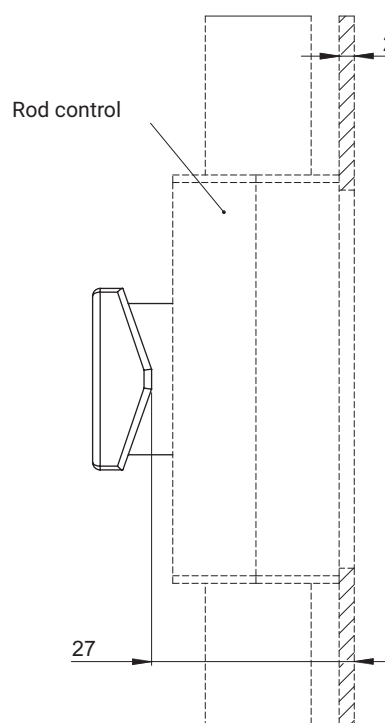
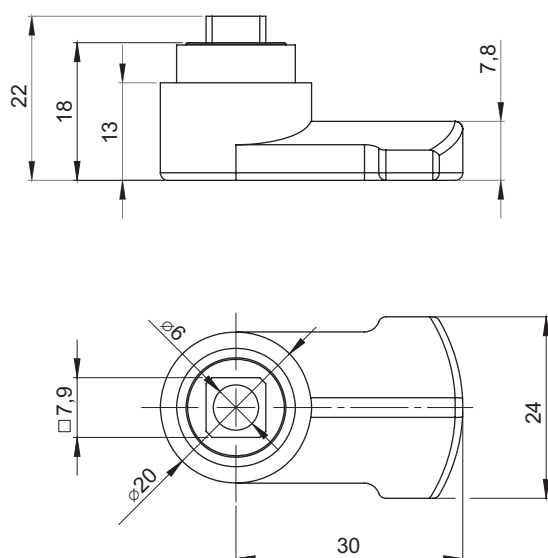

CATALOGUE NO.	DETAIL	MATERIAL
JZN-10027/30	Cam	ZAMAK, zinc plated

Adapter fitted with rod control.
(pg.: 1C-28 - 1C-33)

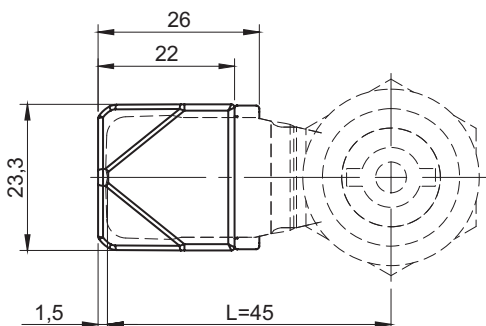
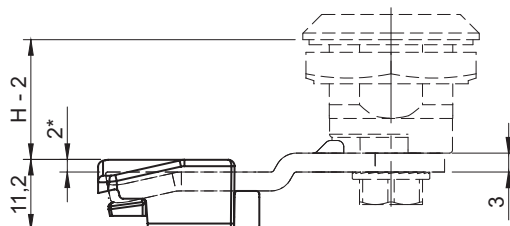

1. Place the clip at the bottom end of the cam

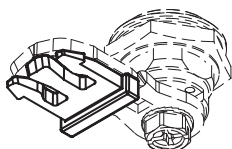

2. Slide the cap onto the clip

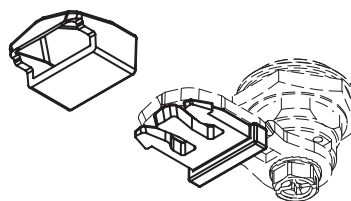

3. Holding the clip and the cam slide the cap on completely

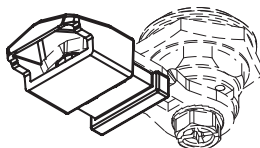

4. The cap will eventually slide into place, signaled by a distinct click

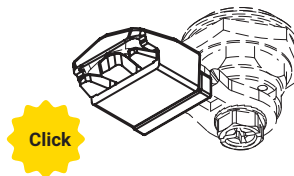

* The addition of the Sliding End Cap decreases the functioning height H by 2mm.

- Good material properties ensure less friction on contact.

- The use of the Sliding End Cap prevents metal-on-metal contact which increases the safety of electrical and electronic components inside the cabinet.

Sliding End Cap 1C.920.001 is compatible with cams:

J-175.20.45, J-175.23.45, J-175.26.45, J-175.29.45,

CATALOGUE NO.

1C.920.001

MATERIAL

Natural POM

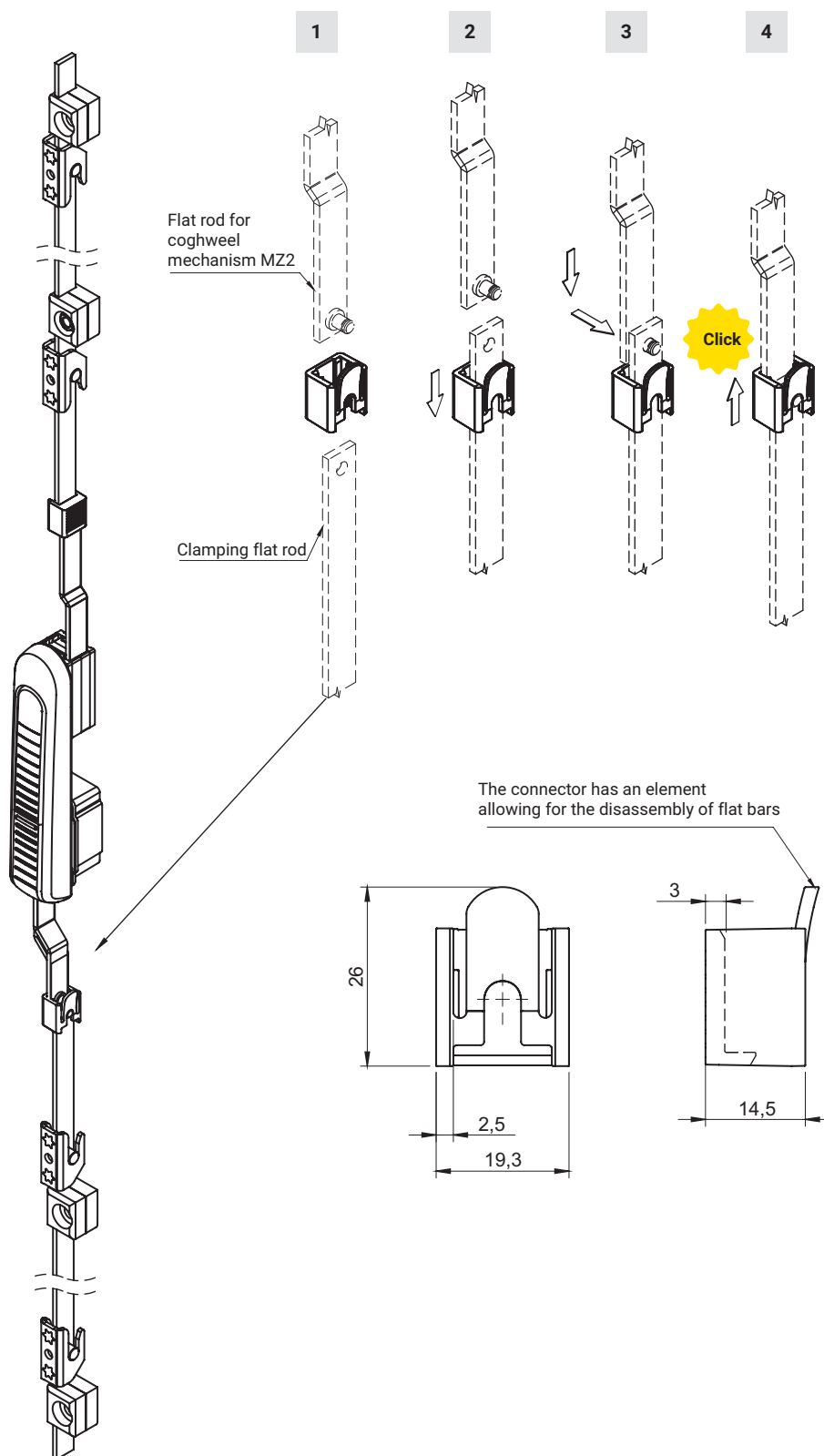

The MZ2 quick-mount bracket for the MZ2 gear unit flat bars with clamping bars is compatible with:

- flat bars with rollers: A20, A25 page 1C-34,
- flat clamping bars on the round hole P: ver. A, ver. B, ver. C, ver. D pg. 1C-36 - 1C-40

CATALOGUE NO.	MATERIAL
1C.921.001	Polyamide PA6 GF30

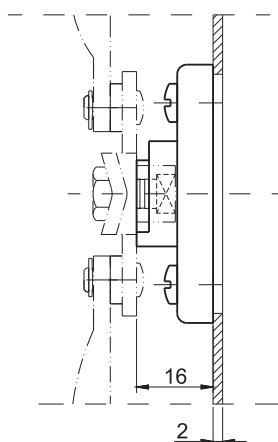

CAP
1C.902.001

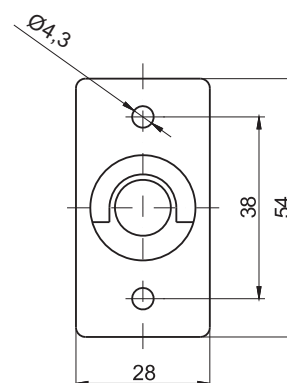

Cap can be fitted with earthing

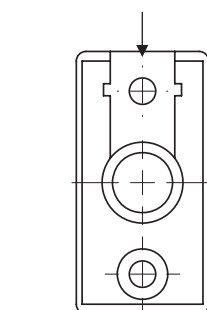

CAP
1C.902.003

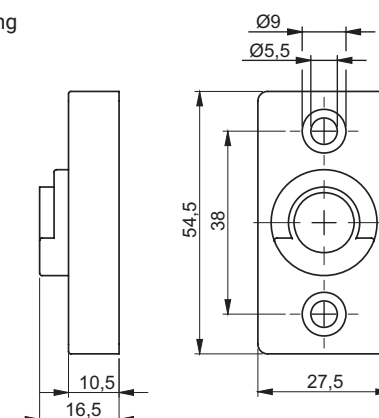

ADAPTER
1C.903.001

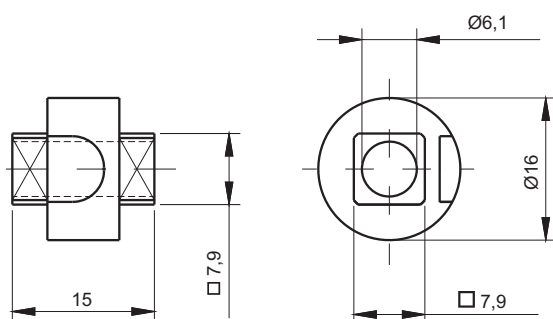

BUSHING

1C.901.001

1C.901.005

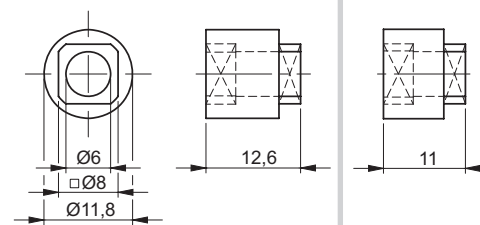

CAT. NUMBER	NAME	MATERIAL
1C.901.001	Bushing for doors at thickness 2,5mm	ZAMAK
1C.901.001SN	Bushing for doors at thickness 2,5mm	Stainless steel
1C.901.005	Bushing for doors at thickness 1,5mm	ZAMAK
1C.901.005SN	Bushing for doors at thickness 1,5mm	Stainless steel
1C.902.001	Cap	ZAMAK
1C.902.001SN	Cap	Stainless steel
1C.902.003	Cap PA	Polyamide
1C.903.001	Adapter	ZAMAK
1C.903.001SN	Adapter	Stainless steel

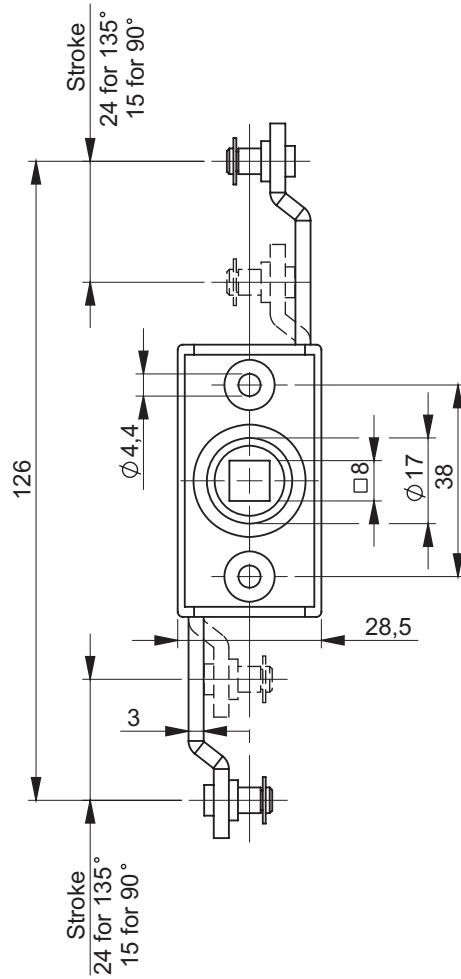
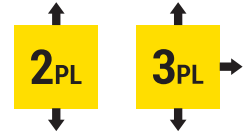

NOTE:
When ordering cogwheel mechanism MZ1K or MZ1P you must order flat rod with correct hole

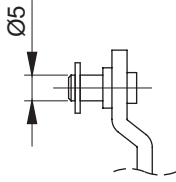
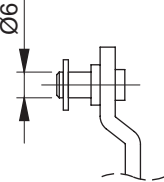
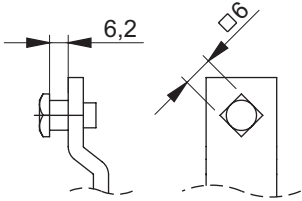
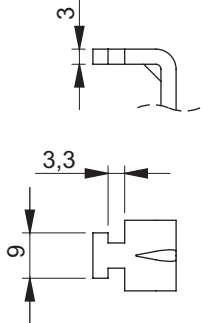
Version	CATALOGUE NO.	COMPONENTS	
		Housing	Flat rods
MZ1 	MZ1	ZAMAK5	Stainless steel
	MZ1-PA	Polyamide PA6	
	MZ1-PA-SN		Stainless steel
	MZ1-SN	Stainless steel	
MZ1-6 	MZ1-6	ZAMAK5	Steel zink plated
	MZ1-6-PA	Polyamide PA6	
	MZ1-6-PA-SN		Stainless steel
	MZ1-6-SN	Stainless steel	
MZ1K 	MZ1K	ZAMAK5	Steel zink plated
	MZ1K-PA	Polyamide PA6	
	MZ1K-PA-SN		Stainless steel
	MZ1K-SN	Stainless steel	
MZ1P 	MZ1P	ZAMAK5	Steel zink plated
	MZ1P-PA	Polyamide PA6	
	MZ1P-PA-SN		Stainless steel
	MZ1P-SN	Stainless steel	

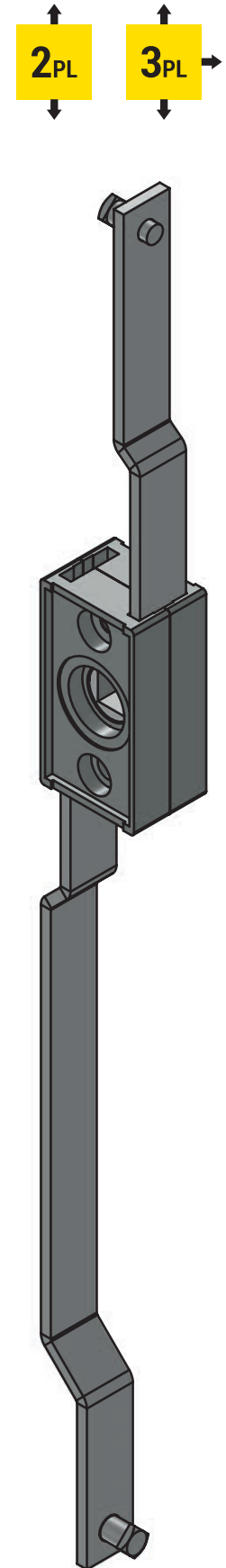
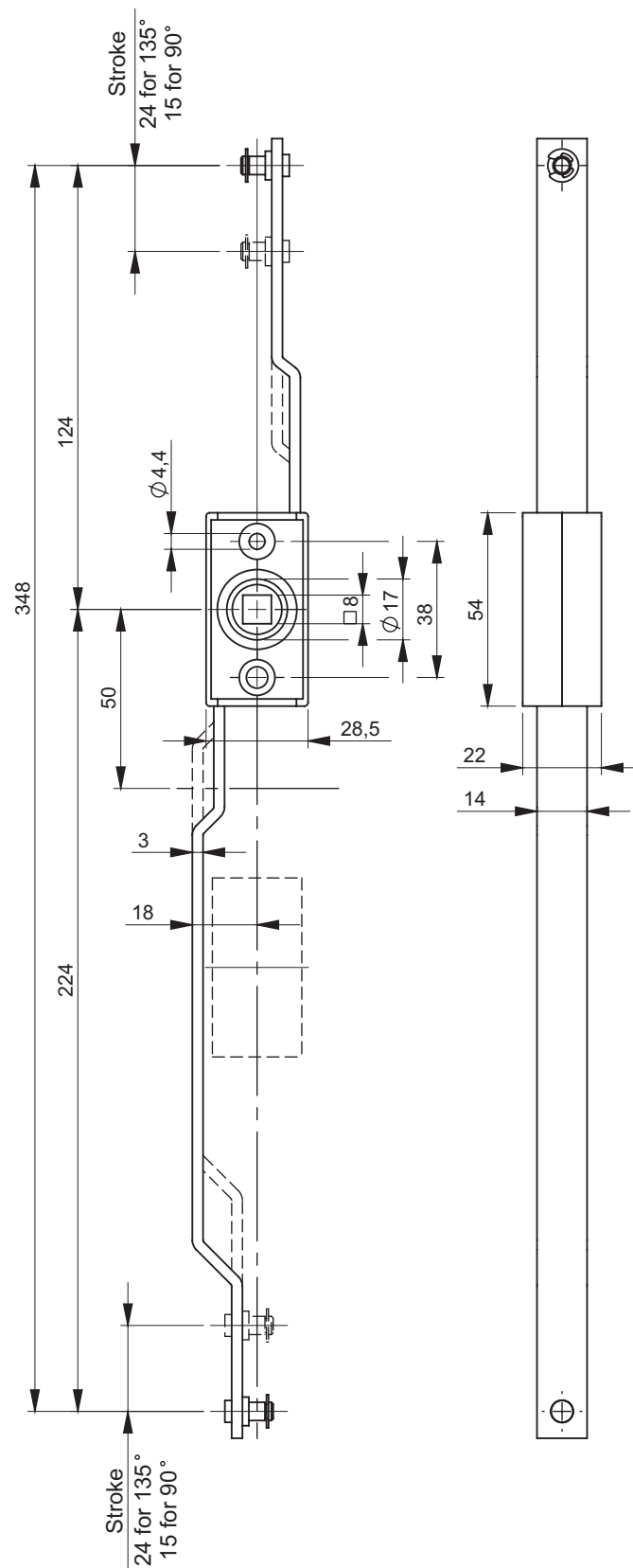

NOTE:
When ordering cogwheel mechanism MZ2K or MZ2P you must order flat rod with correct hole

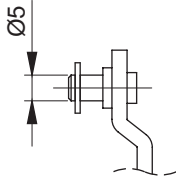
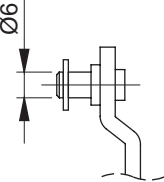
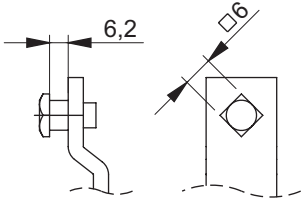
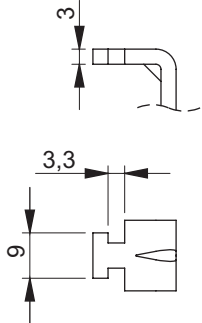
Version	CATALOGUE NO.	COMPONENTS	
		Housing	Flat rods
MZ2 	MZ2	ZAMAK5	Stainless steel
	MZ2-PA	Polyamide PA6	
	MZ2-PA-SN		Stainless steel
	MZ2-SN	Stainless steel	
MZ2-6 	MZ2-6	ZAMAK5	Steel zink plated
	MZ2-6-PA	Polyamide PA6	
	MZ2-6-PA-SN		Stainless steel
	MZ2-6-SN	Stainless steel	
MZ2K 	MZ2K	ZAMAK5	Steel zink plated
	MZ2K-PA	Polyamide PA6	
	MZ2K-PA-SN		Stainless steel
	MZ2K-SN	Stainless steel	
MZ2P 	MZ2P	ZAMAK5	Steel zink plated
	MZ2P-PA	Polyamide PA6	
	MZ2P-PA-SN		Stainless steel
	MZ2P-SN	Stainless steel	

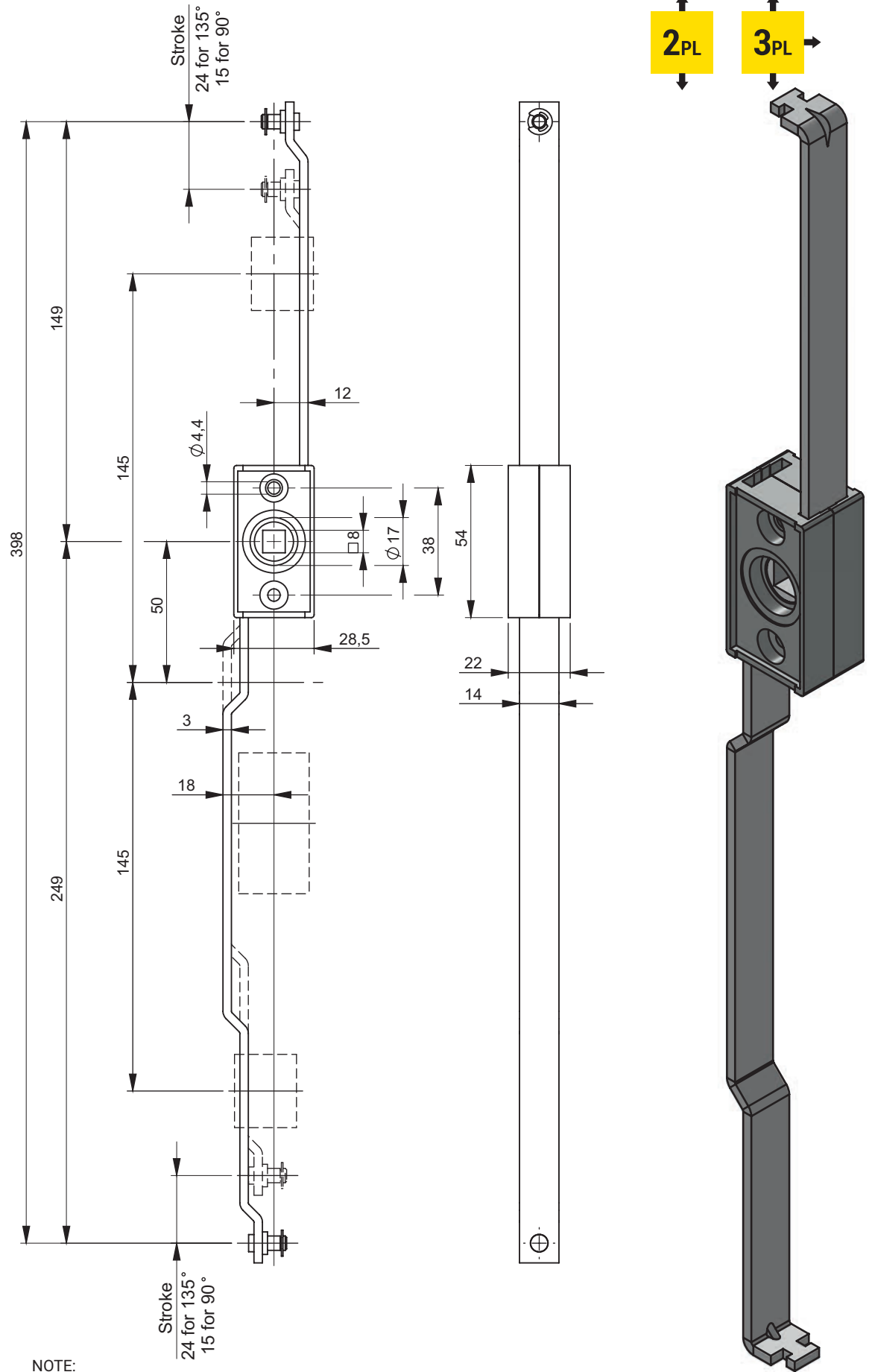

NOTE:
When ordering cogwheel mechanism MZ3K or MZ3P you must order flat rod with correct hole

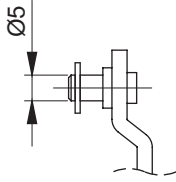
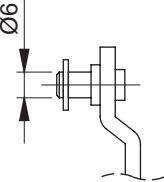
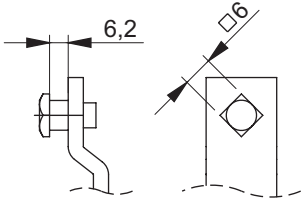
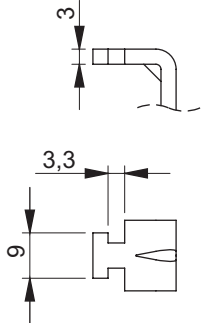
Version	CATALOGUE NO.	COMPONENTS	
		Housing	Flat rods
MZ3 	MZ3	ZAMAK5	Steel zink plated
	MZ3-PA	Polyamide PA6	
	MZ3-PA-SN		Stainless steel
	MZ3-SN	Stainless steel	
MZ3-6 	MZ3-6	ZAMAK5	Steel zink plated
	MZ3-6-PA	Polyamide PA6	
	MZ3-6-PA-SN		Stainless steel
	MZ3-6-SN	Stainless steel	
MZ3K 	MZ3K	ZAMAK5	Steel zink plated
	MZ3K-PA	Polyamide PA6	
	MZ3K-PA-SN		Stainless steel
	MZ3K-SN	Stainless steel	
MZ3P 	MZ3P	ZAMAK5	Steel zink plated
	MZ3P-PA	Polyamide PA6	
	MZ3P-PA-SN		Stainless steel
	MZ3P-SN	Stainless steel	

FLAT ROD WITH ROLLERS A25 L (with round hole)

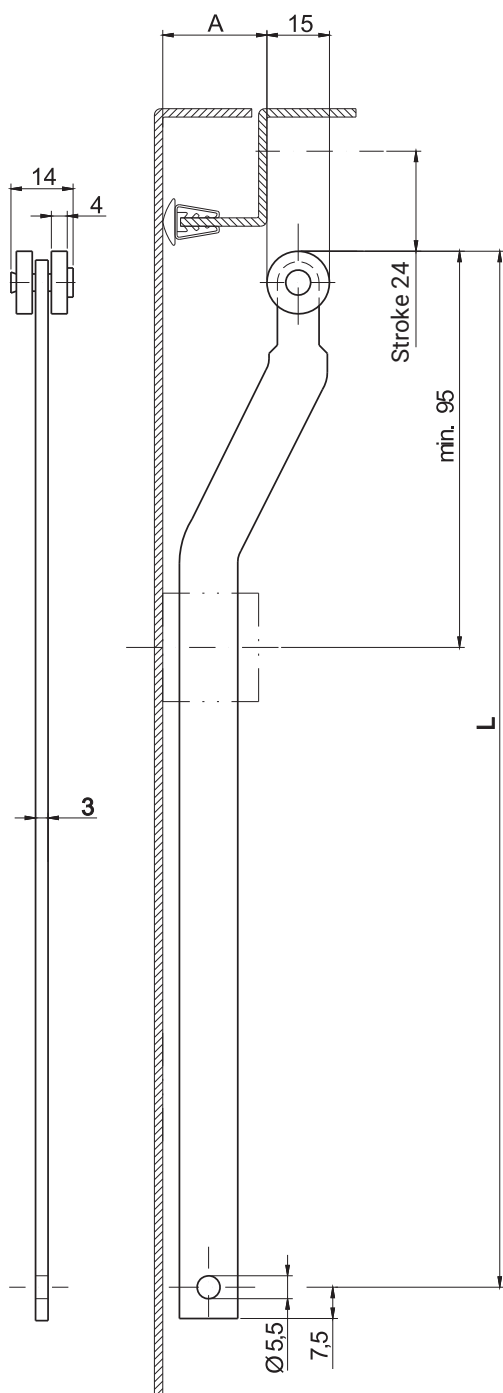

FLAT ROD WITH ROLLERSI A25K - L (with square hole)

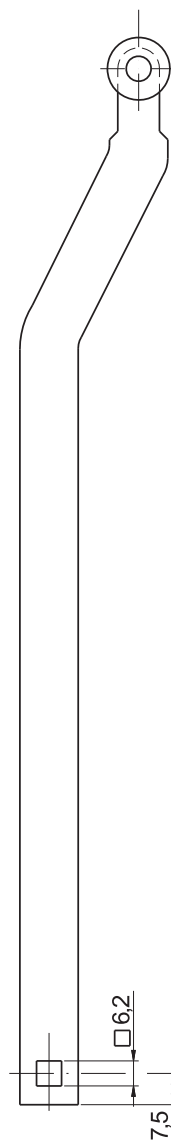

FLAT ROD WITH ROLLERS A25P - L

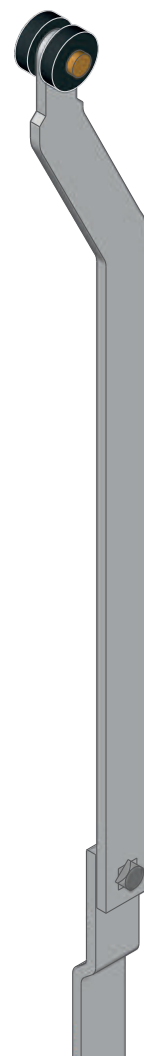
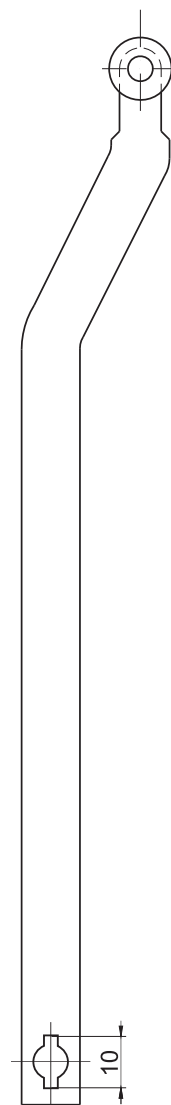

NOTE: Additionally possibility of ordering rubber profile, page 6-1 to 6-15, 6-10 to 6-11

CAT. NUMBER	NAME	MATERIAL	DIMENSIONS	
			A	L
A20 - L	Flat rod with rollers with round hole	Flat rod - steel zinc plated Rollers - PA6	20	Dimensions negotiable
A25 - L			25	
A20K - L	Flat rod with rollers with square hole		20	
A25K - L			25	
A20P - L	Flat rod with rollers A20P - L, A25P - L		20	
A25P - L			25	

• **Fox example:** A25K-300 means flat rod 3x14mm, dimension A=25, length L=300mm with square hole

• **Possibility** of producing other flat rod on special request

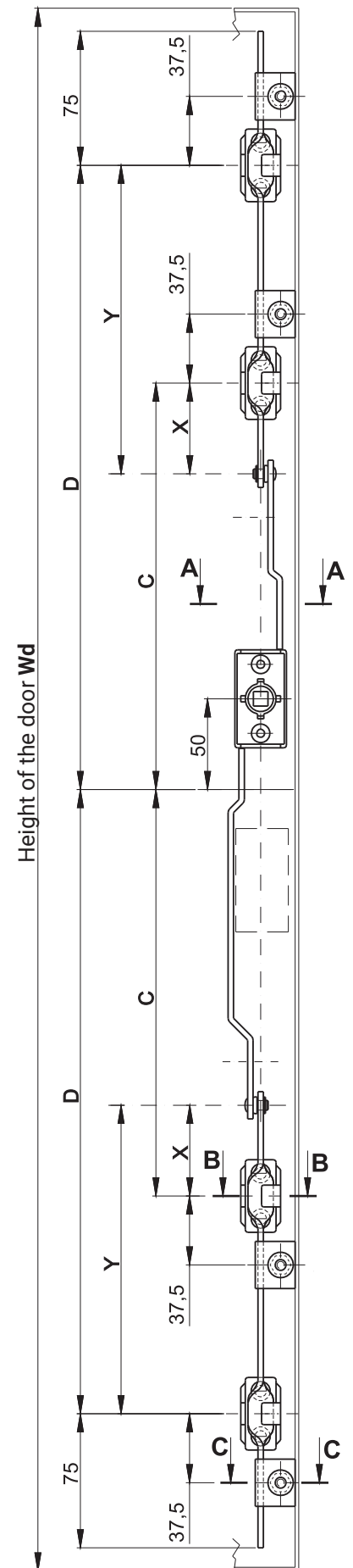
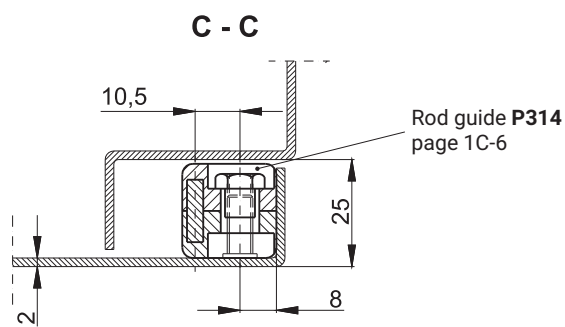
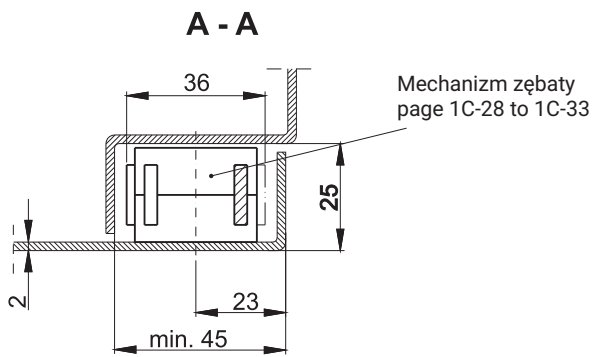
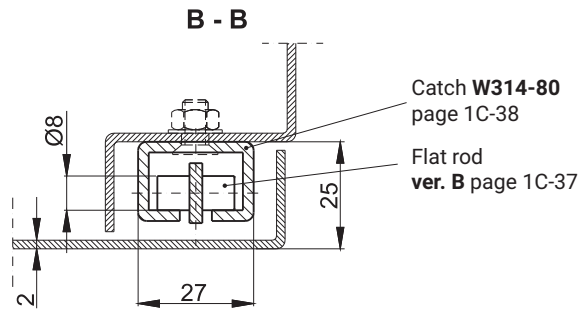
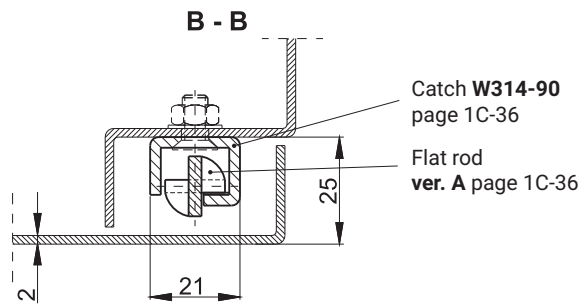
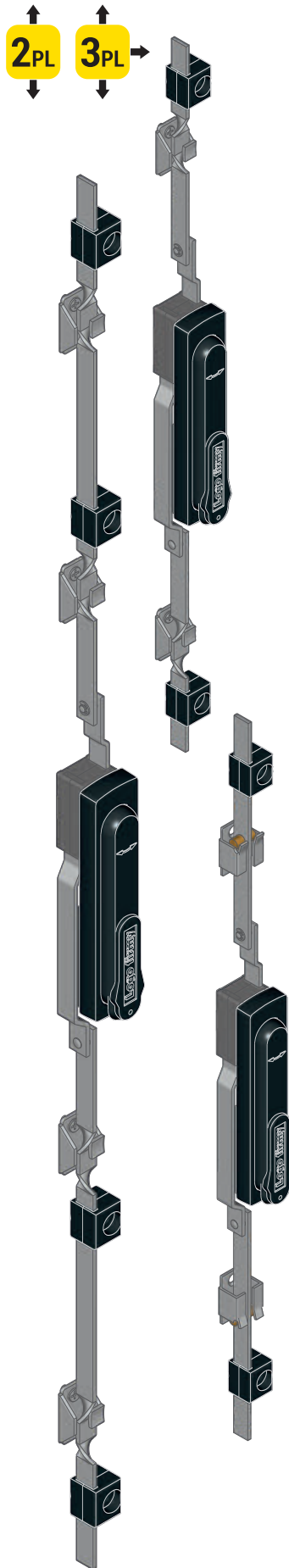

FLAT ROD ver. A

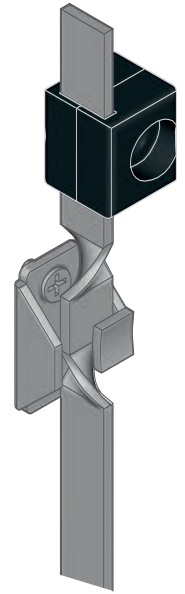
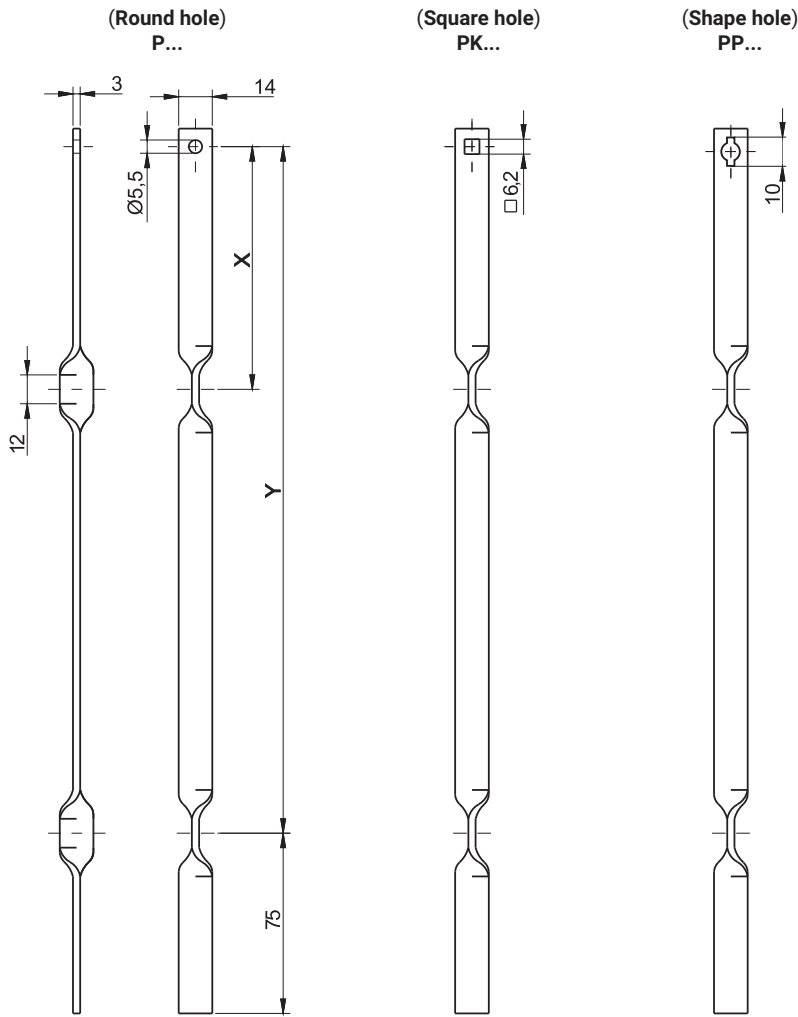

CATCH W314-90 (for Flat Rod ver.A - znal)

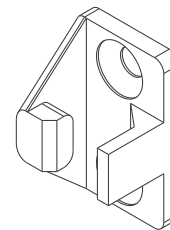
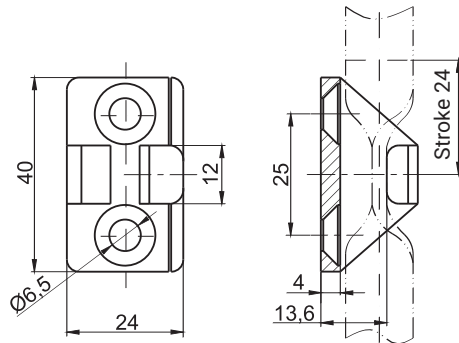

CATALOGUE NUMBER FLAT ROD VER. A			DOOR HEIGHT Wd	DIMENSION TO THE FLAT ROD		DIMENSION TO DOOR CENTER		MATERIAL
Round hole	Square hole	Shape hole		X	Y	C	D	
P190-210	PK190-210	PP190-210	800 - 1200	-	126	-	300	Steel zinc plated
P190-351	PK190-351	PP190-351	1200 - 1600	-	276	-	450	
P290-601	PK290-601	PP290-601	1600 - 1900	101	526	275	700	
P290-751	PK290-751	PP290-751	1900 - 2200	101	676	275	850	

CAT. NUMBER	NAME	MATERIAL
1C.907.001	Catch for flat rod ver. A	ZAMAK - powder painted

FLAT ROD ver. B

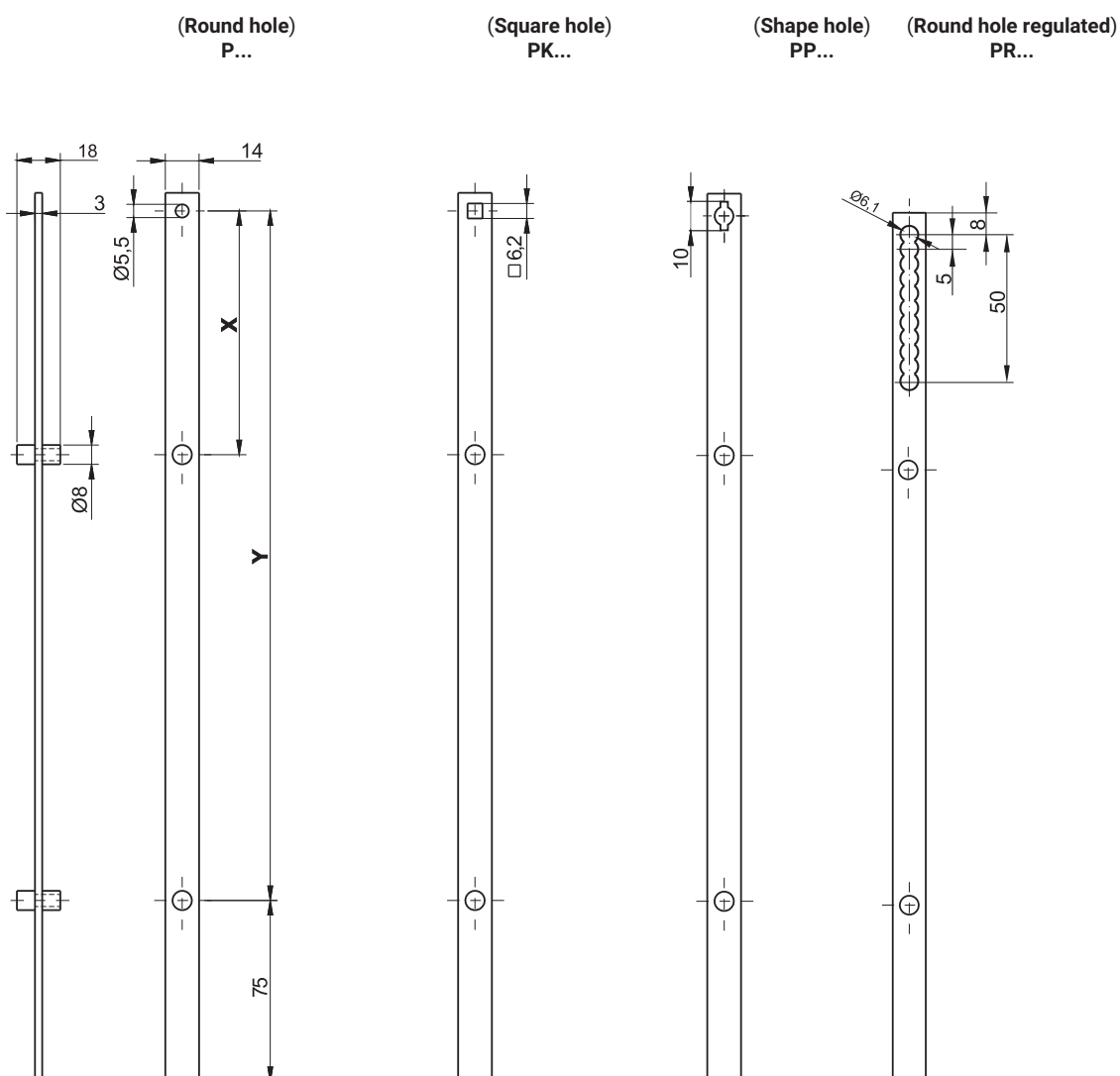

CATALOGUE NUMBER FLAT ROD VER. B			DOOR HEIGHT Wd	DIMENSION OF THE FLAT ROD		DIMENSION TO DOOR CENTER		MATERIAL
Round hole	Square hole	Shape hole		X	Y	C	D	
P18-210	PK18-210	PP18-210	800 - 1200	-	126	-	300	Steel zinc plated
P18-351	PK18-351	PP18-351	1200 - 1600	-	276	-	450	
P28-601	PK28-601	PP28-601	1600 - 1900	101	526	275	700	
P28-751	PK28-751	PP28-751	1900 - 2200	101	676	275	850	

Dimensions C and D page 1C-35.

Catch for flat rod ver. B

Distance D314-85

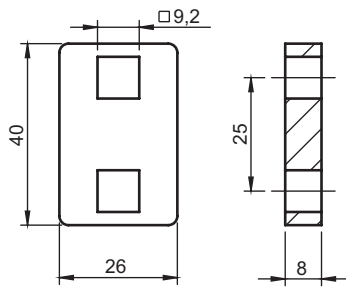

Catch W314-85-A
1C.907.003-A

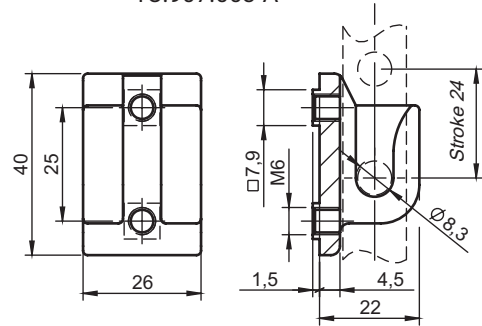

Catch W314-85-D
1C.907.003-D

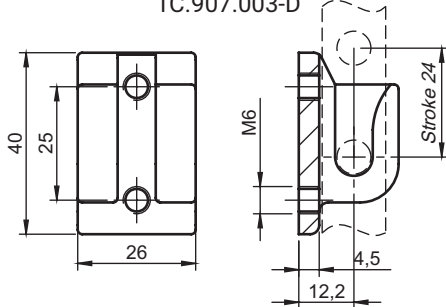

Catch W314-85-C
1C.907.003-C

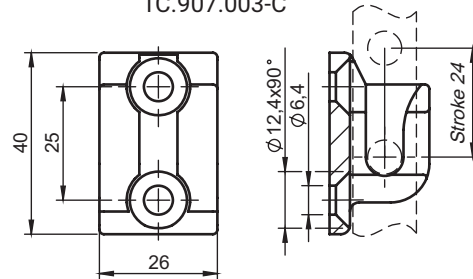

Catch W314-85-B
1C.907.003-B

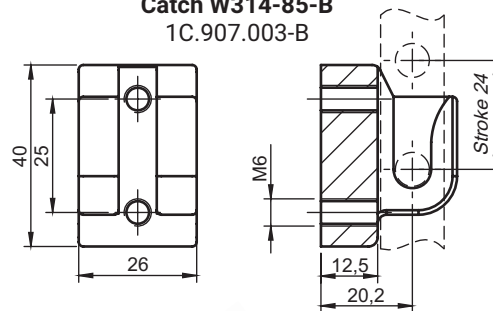

Catch W314-80
1C.907.002

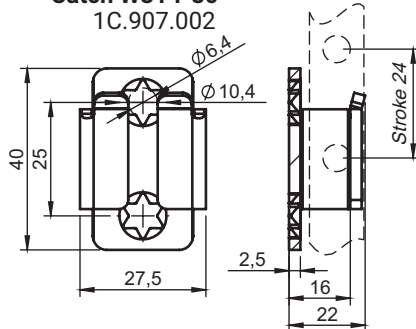

Catch W314-60
1C.907.007

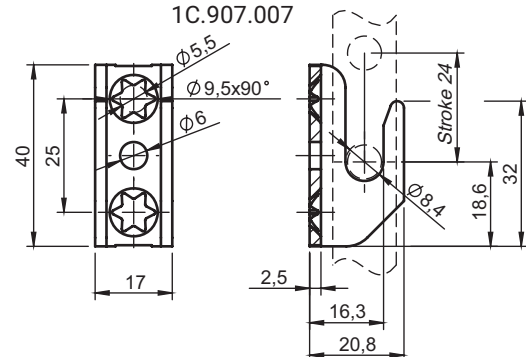

CAT. NUMBER	NAME	MATERIAL
1C.908.001	Distance D314-85 for catch 1C.907.003.001	ZAMAK5
1C.907.003-A	Catch W314-85-A	ZAMAK5
1C.907.003-B	Catch W314-85-B	ZAMAK5
1C.907.003-C	Catch W314-85-C	ZAMAK5
1C.907.003-C SN	Catch W314-85-C	Stainless steel
1C.907.003-D	Catch W314-85-D	ZAMAK5
1C.907.002	Catch W314-80	Steel zinc plated
1C.907.007	Catch W314-60	Steel zinc plated

FLAT ROD ver. C

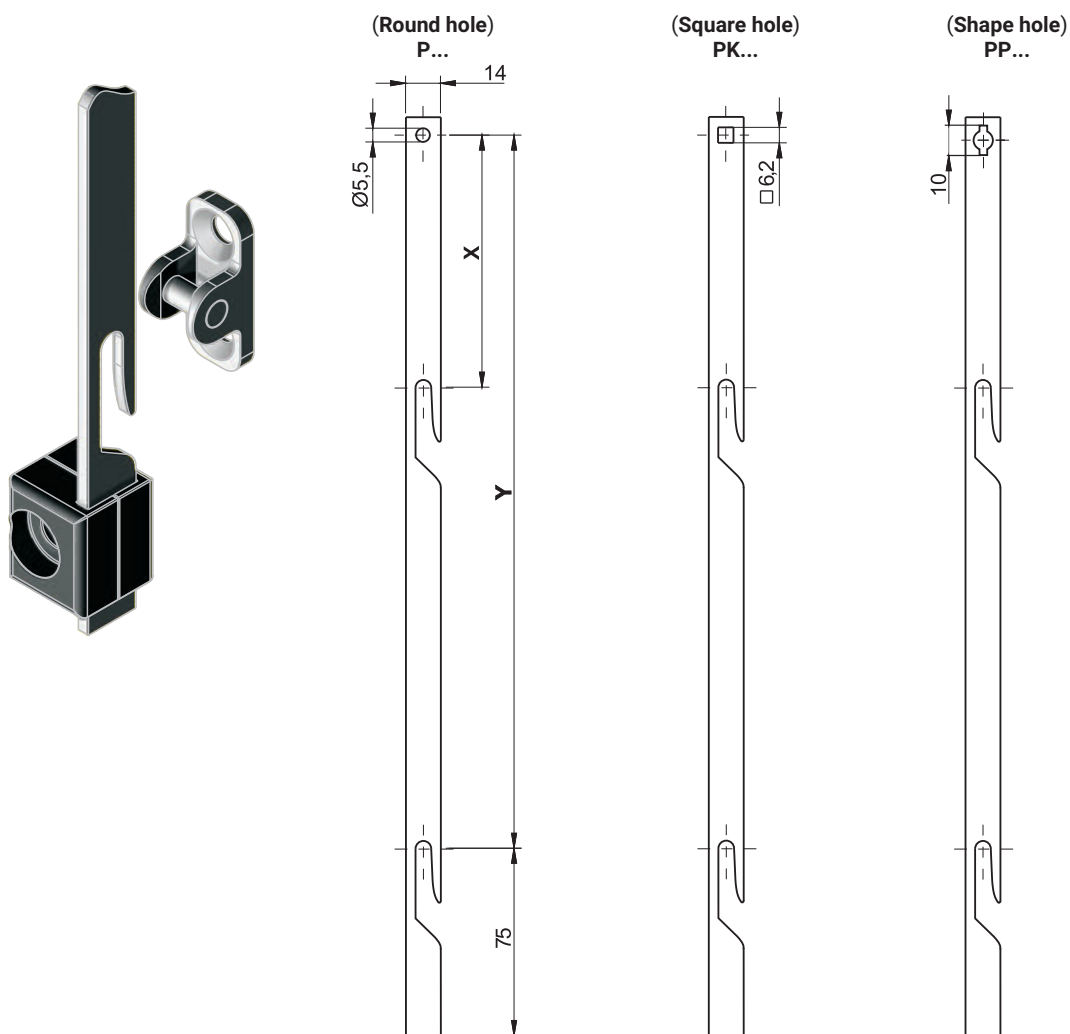

CATCH W314-70 (for Flat Rod ver. C - steel)

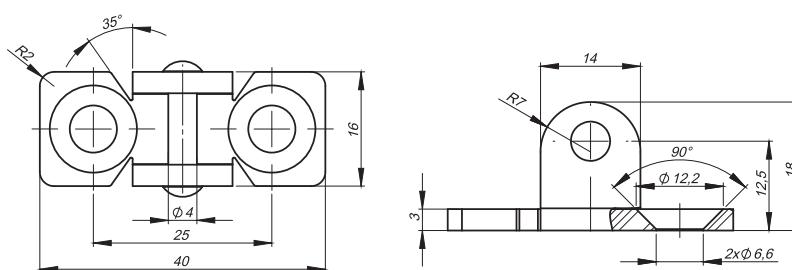

CATALOGUE NUMBER FLAT ROD VER. C			DOOR HEIGHT Wd	DIMENSION OF THE FLAT ROD		DIMENSION TO DOOR CENTER		MATERIAL
Round hole	Square hole	Shape hole		X	Y	C	D	
P390-210	PK390-210	PP38-210	800 - 1200	-	126	-	300	Steel zinc plated
P390-351	PK390-351	PP38-351	1200 - 1600	-	276	-	450	
P490-601	PK490-601	PP48-601	1600 - 1900	101	526	275	700	
P490-751	PK490-751	PP48-751	1900 - 2200	101	676	275	850	

CAT. NUMBER	NAME	MATERIAL
1C.907.004	Catch for flat rod ver. C	Steel zinc plated

FLAT ROD ver. D

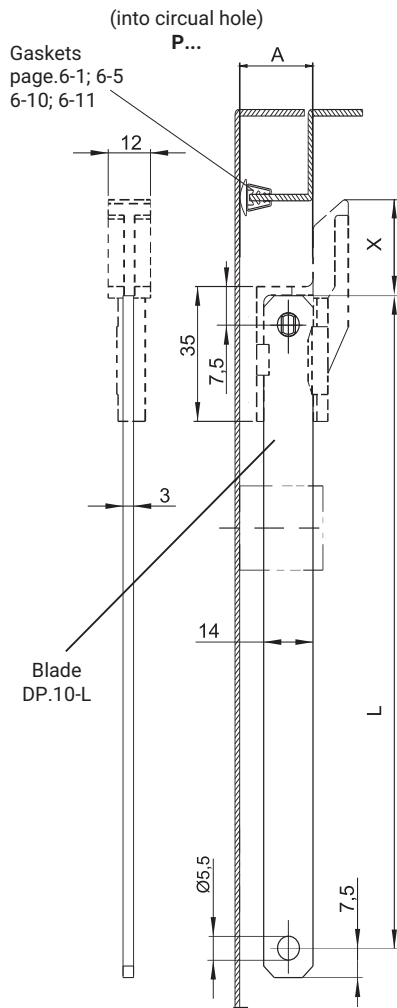

(into square hole)
PK...

Grip handle
904.053; X=24,4
904.054; X=14,4

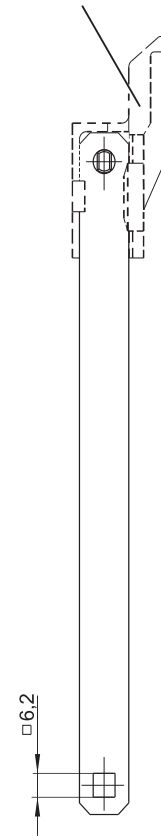

(into shape hole)
PP...

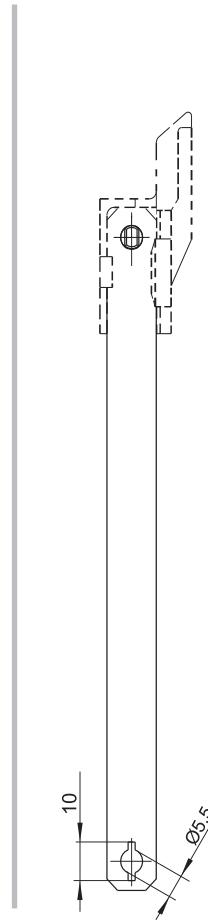

GRIP HANDLE
1C.904.053

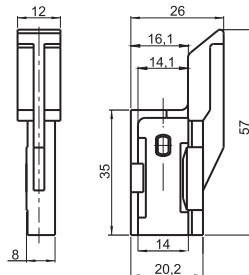

GRIP HANDLE
1C.904.054

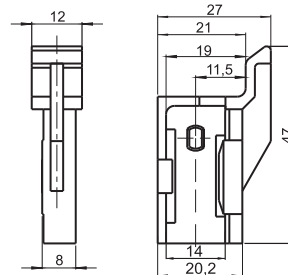

CAT. NUMBER		NAME	DIMENSION		MATERIAL
Steel zinc plated	Steel 1.4301		L		
DP.01 - L	DP.02 - L	Band pressing into circular hole	400	Other dimensions to be agreed	Band pressing - steel zinc plated, stainless steel
DPK.01 - L	DPK.02 - L		500		
DPP.01 - L	DPP.02 - L	Band pressing into square hole	600		
			700		
DPP.01 - L	DPP.02 - L	Band pressing into shaped hole	800		
			900		
			1000		
			A		
1C.904.053		Grip handle	17,5		PA-6 RAL9005
1C.904.054			22,5		

- **Order example:** A23K-300 means band pressing 3x14mm, dimension A=23, length of L=300mm into square
- **Capability of execution flat according to individual orders**

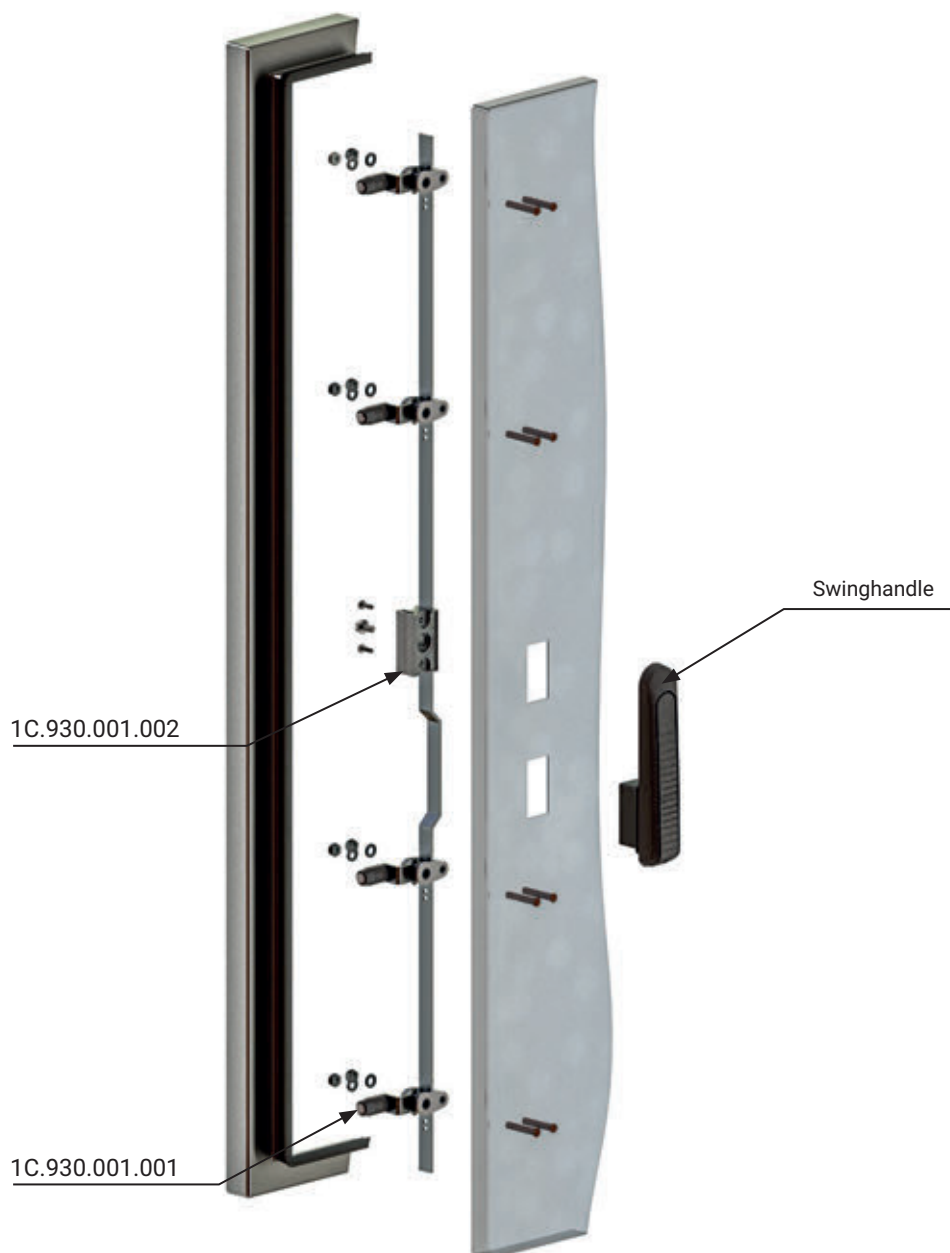

CATALOGUE NUMBER	DESCRIPTION	COMPONENTS	MATERIAL
1C.930.001.001	Bolt	Roll	POM
		Cam	Steel zinc plated
1C.930.001.002	Cogwheel mechanism with flat rod	Housing	ZAMAK
		Flat rod	Steel zinc plated

How to order :

Catalogue number

1C.930.001.002 — L1 — L2 — L3 — L4

** distance between locks

**for the 1C.390.001.002 detail, the lengths L1, L2, L3 and L4 must be additionally specified in case of a 2-point system, indicate only the lengths L1 and L2

Individual system components to be ordered separately

Multipoint locking system with one flat bar

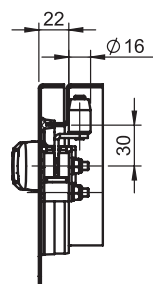
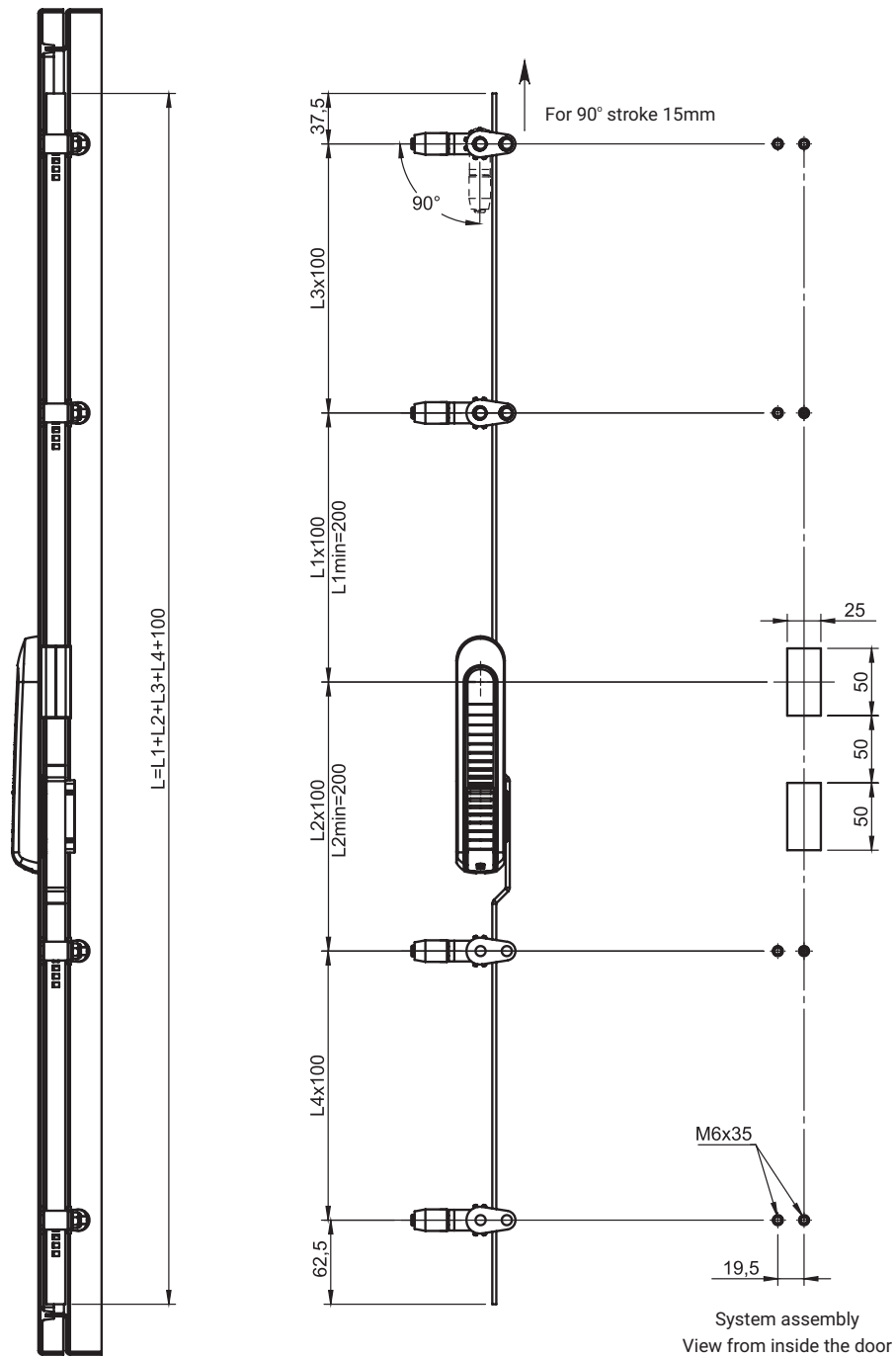

For 2-point system L3 and L4=0
 Maximum total length of flat bar L = 2000mm
 The system works with all locks for the mounting hole 50x50x50mm



1C.916.001

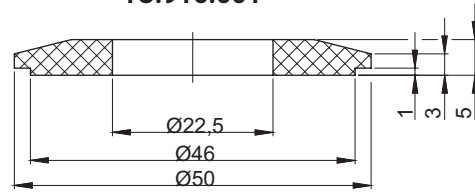

1C.916.002

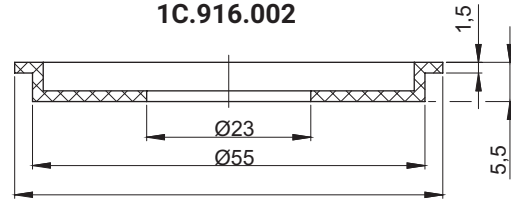

1C.916.003

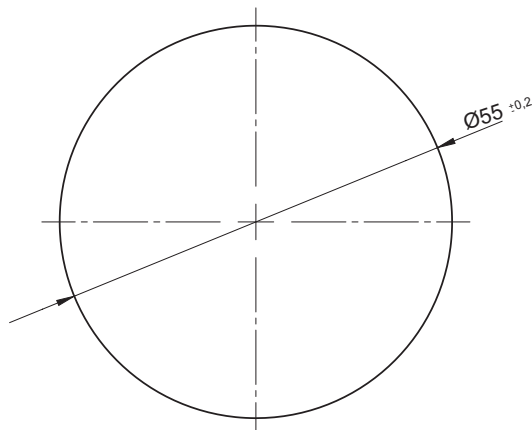
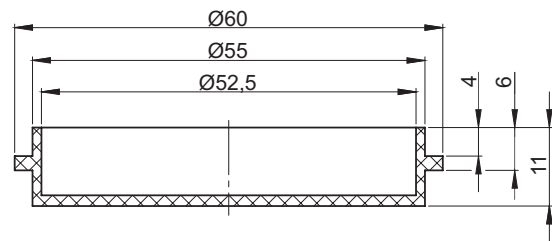

Cut out 1C.916.002 i 1C.916.003

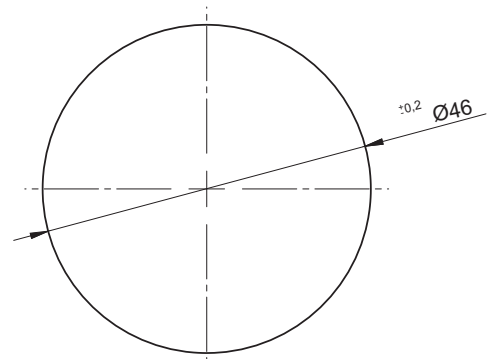

Cut out 1C.916.001

CATALOGUE NO.	DETAIL	MATERIAL
1C.916.001	Adapter RS Ø23-Ø46	Polyamide
1C.916.002	Adapter RS Ø23-Ø55	
1C.916.003	Adapter RS Ø55	



1

Locking systems

2

Locks
Latches



3

Hinges

4

Clamps



5

Accessories



6

Gasketing profiles

7

Custom products



Locks in the closed position
arrow indicates the direction of opening

LOCKS FOR LEFT DOORS

LOCKS FOR RIGHT DOORS

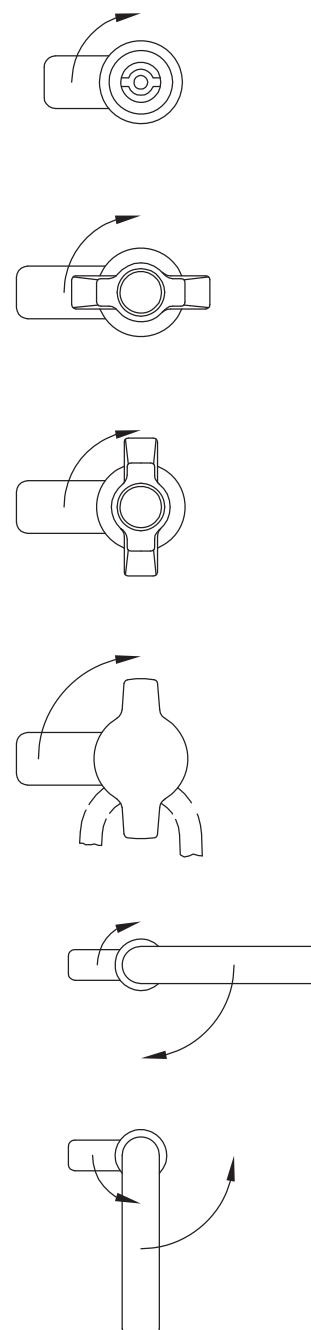
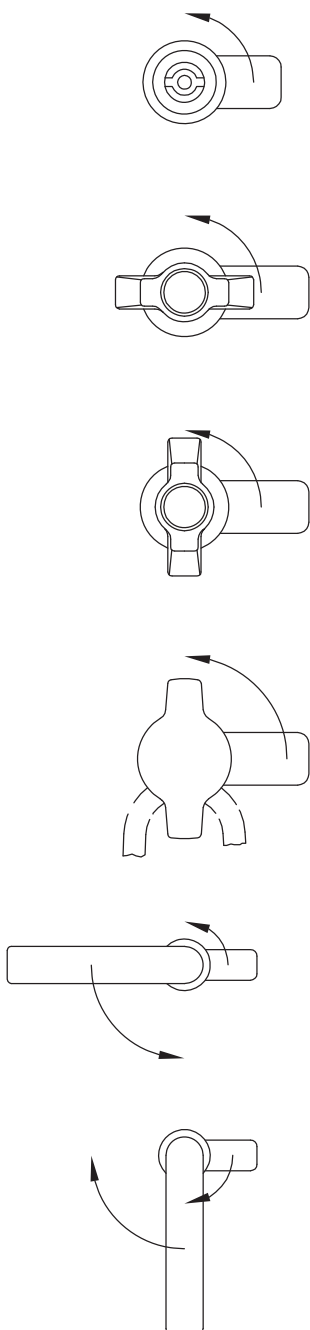

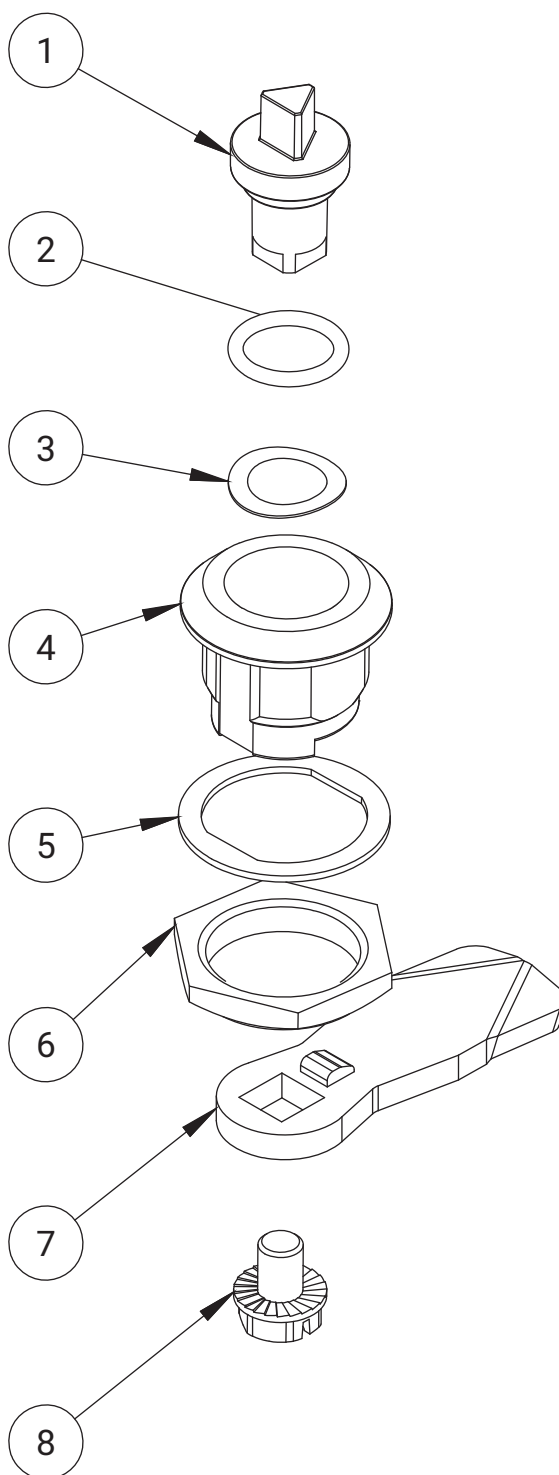

- where :
- 1 - Insert
 - 2 - O-ring for IP 65
 - 3 - Wave washer
 - 4 - Housing
 - 5 - Flat seal for IP 65 and IP 66
 - 6 - Nut M22
 - 7 - Cam
 - 8 - Screw M6

INSERT



INSERT PATENT WITH CODE KEY:



- 1333
- RK - different key code
- 1242E
- 405E
- 455E
- 2342E
- MS - Master Key

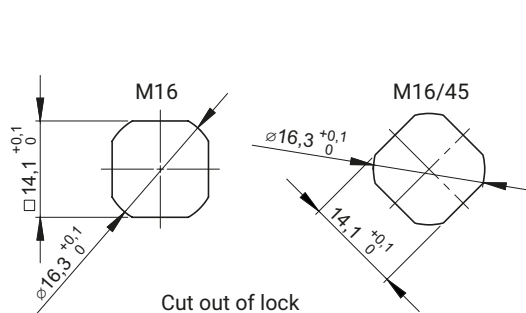

Cut out of lock

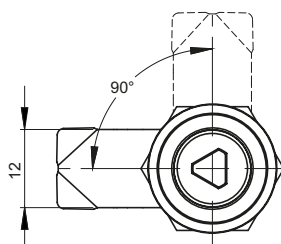
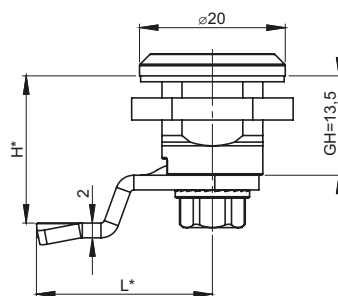

Material for insert [D]	INSERTS AVAILABLE						
	T6	T7	T7S	S	N	KW6	HEX
ZAMAK 5	11	12	13	14	-	16	17
Brass	21	-	-	-	25	-	-

TYPE OF LOCK								
M16					M16/45			
MATERIAL TYPE FOR HOUSING AS WELL AS PROTECTIVE COATING FOR HOUSING AND INSERT [C]								
ZAMAK 5						Stainless steel		
Chrome	Nickel	Zinc plated	RAL 9005	RAL 7035	No coating	304	316	
01	02	03	04	05	0	9.1	9.2	
TYPE OF NUT [N]						Stainless steel		
Steel						304	316	
13						14	15	

How to order :

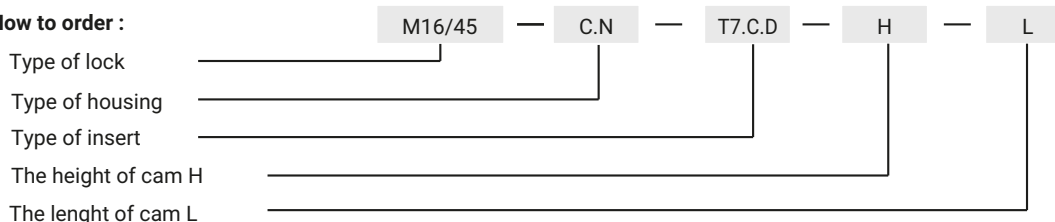

Available height of cam H = 13,5; 20

Available length of cam L = 23; 25

For the housing made of stainless steel, the insert is also made of the same material

* Possibility to order in a different dimension

meaning: C - marking of material for housing as well as surface finish for housing and insert
H.G - cam bended dimension

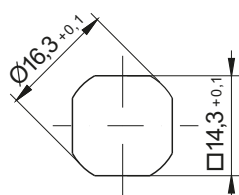

Cut Out

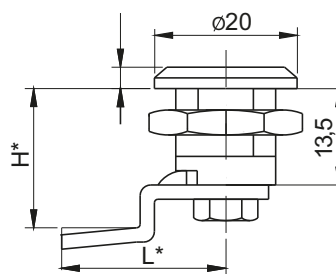

INSERTS	FINISH [C]
	RAL 9005
SK	04

NAME	COMPONENTS	MATERIAL
Lock 2.602.001	Housing, insert	ZAMAK5
	Cam	Steel zinc plated

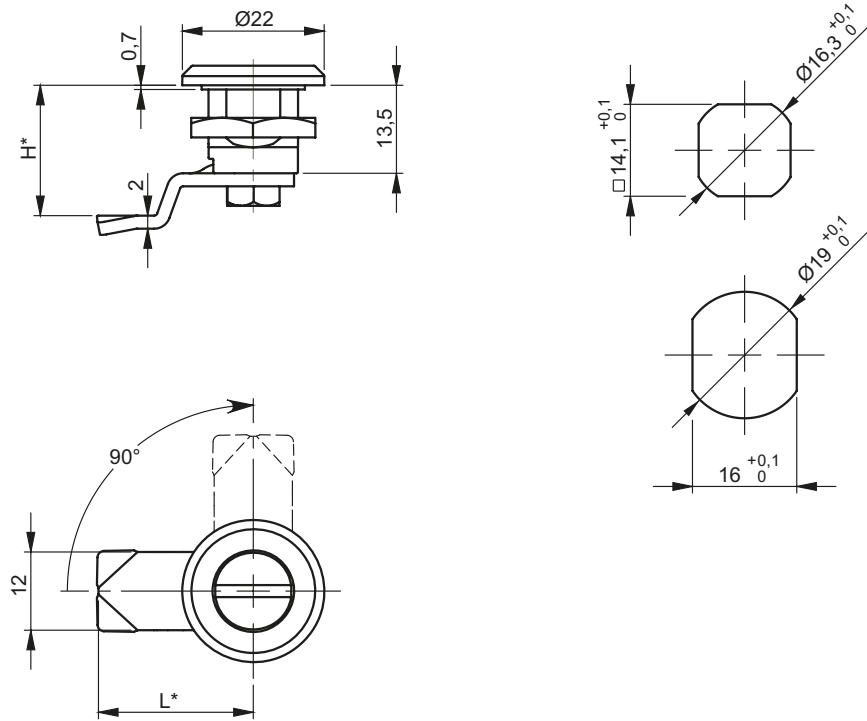

Material for insert [D]	INSERTS AVAILABLE						
	T6	T7	T7S	S	N	KW6	HEX
ZAMAK 5	11	12	13	14	-	16	17
Brass	21	-	-	-	25	-	-

TYPE OF LOCK								
M16-19								
MATERIAL TYPE FOR HOUSING AS WELL AS PROTECTIVE COATING FOR HOUSING AND INSERT [C]								
ZAMAK 5						Stainless steel		
Chrome	Nickel	Zinc plated	RAL 9005	RAL 7035	No coating	304	316	
01	02	03	04	05	0	9.1	9.2	
TYPE OF NUT [N]						Stainless steel		
Steel						304	316	
13						14	15	

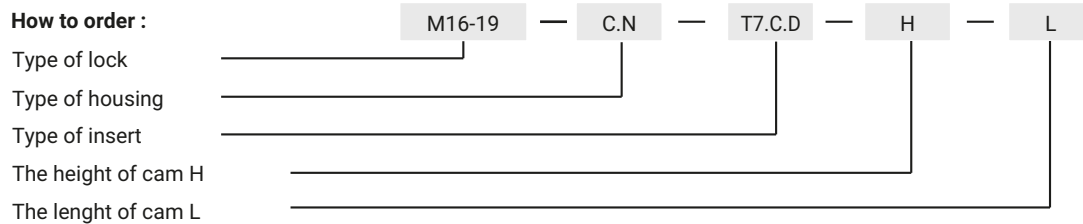

Height dimension of a CAM H for a body 13,5mm-mounting in hole Ø19x16, in case of mounting in hole Ø16x14 the height H decreases about 0,7mm.

Mounting options:

- Ø16x14
- Ø19x16

* different dimensions available

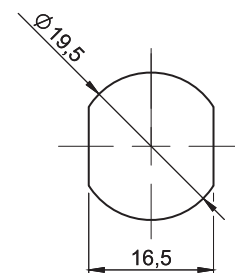
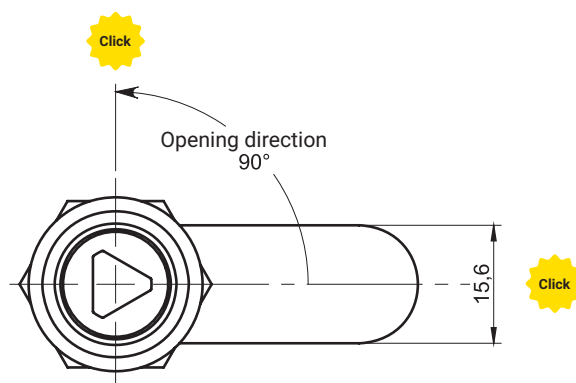
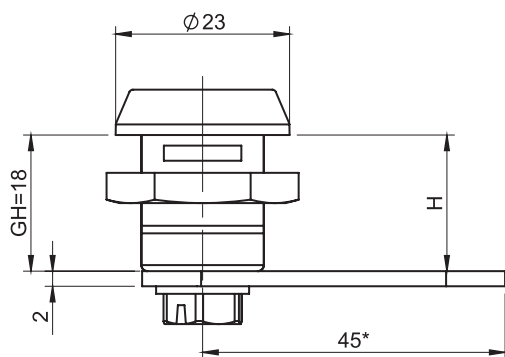

Mounting hole

CATALOGUE NUMBER	COMPONENTS	MATERIAL
M19-1	Housing, Insert	ZAMAK
	Cam	Steel zinc plated

INSERT [X]		FINISH [C]				
		Chrome	Nickel	Galvanized	RAL9005	RAL7035
KW8	T8	01	02	03	04	05

How to order:

Catalogue number

Type of insert [X]

Finish [C]

Locking height, H=18, 20, 22

Version (P-right, L-left)

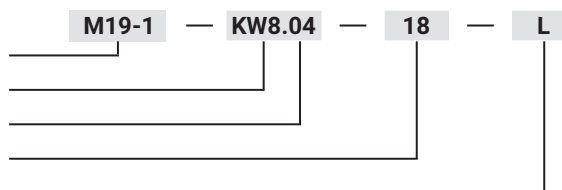

The drawing shows the left-hand version. The right-hand version is a mirror reflection.

* possibility to order in another dimension

IP65

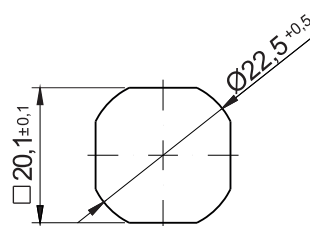
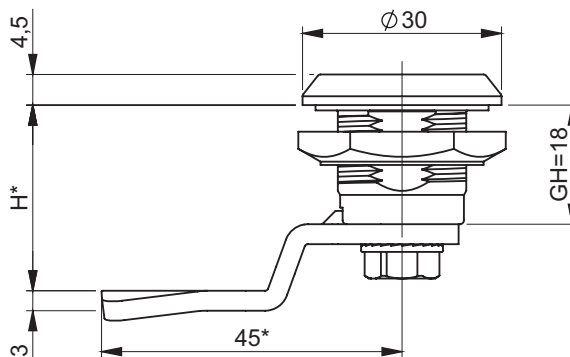

Mounting hole

FINISHING TYPE OF THE INSERT AND THE BODY [C]

ZAMAK 5						Polyamide		Stainless steel	
Chrome	Nickel	Galvanized	RAL 9005	RAL 7035	No coating	RAL 9005	RAL 7035	304	316
01	02	03	04	05	0	-	-	9.1	-

THE TYPE OF THE NUT [N]

	ZAMAK 5	Polyamide	Steel	Stainless steel	
				304	316
Nut without grounding	11	12	13	14	15
Nut with grounding	21	-	23	24	25

INSERTS AVAILABLE

Type of the material of the insert				
	D3	D5	T9	KW 8
ZAMAK 5	●	●	●	●

How to order:

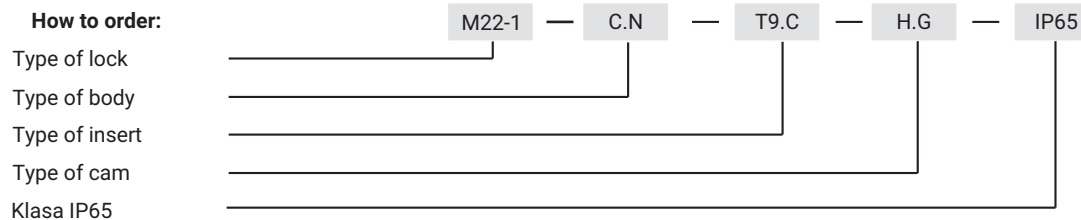

where C,N, G stand for:

C - type of the material and finishing of the surface

N - type of nut

H.G - the cam unbending dimension to be chosen from pages 1C-9 to 1C-22

Notice:

Lock M22-1 is compatible with all cams from range : 11, 12, 13, 14, 31, 32, 18, 33, 34, 38, JZ-002, JK-1610

IP65

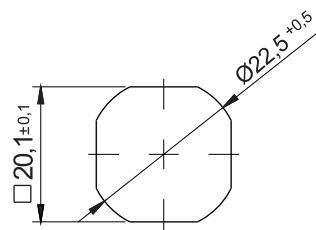
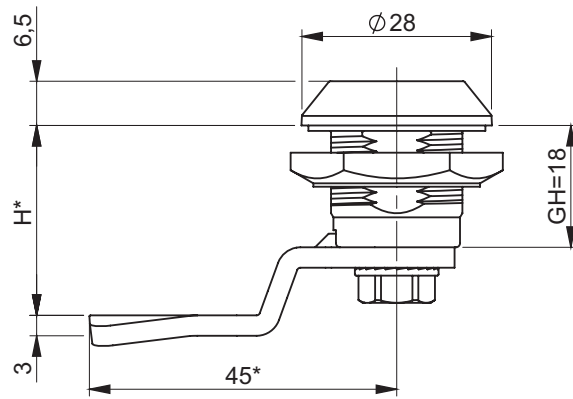

Mounting hole

FINISHING TYPE OF THE INSERT AND THE BODY [C]

ZAMAK 5						Polyamide		Stainless steel	
Chrome	Nickel	Galvanized	RAL 9005	RAL 7035	No coating	RAL 9005	RAL 7035	304	316
01	02	03	04	05	0	7	8	9.1	-

THE TYPE OF THE NUT [N]

	ZAMAK 5	Polyamide	Steel	Stainless steel	
				304	316
Nut without grounding	11	12	13	14	15
Nut with grounding	21	-	23	24	25

Type of the material of the insert	INSERTS AVAILABLE										
	D3	D5	T8	T9	KW 8	S	N	C9	HEX	T13	T13S
ZAMAK 5	●	●	●	●	●	●	●	●	●	●	●

How to order:

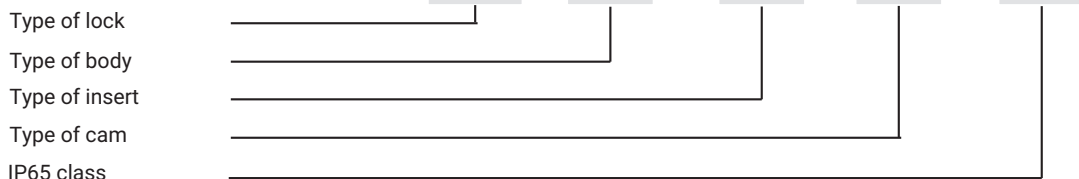

where C,N, G stand for:

C - type of the material and finishing of the surface

N - type of nut

H.G - the cam unbending dimension to be chosen from pages 1C-9to 1C-22

Notice:

Lock M22-2 is compatible with all cams from range : 11, 12, 13, 14, 18, 31, 32, 33, 34, 38, JZ-002, JK-1610

IP65

IP66**

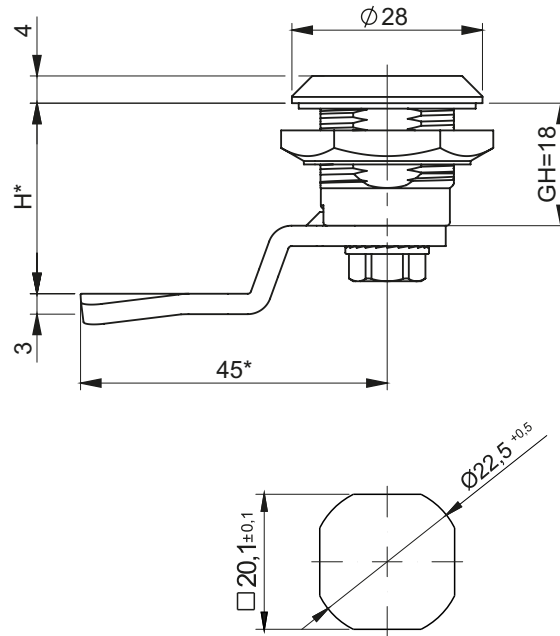

Mounting hole

FINISHING TYPE OF THE INSERT AND THE BODY [C]

ZAMAK 5				Polyamide				Stainless steel		
Chrome	Nickel	Galvanized	RAL 9005	RAL 7035	KTL****	No coating	RAL 9005	RAL 7035	304	316
01	02	03	04	05	06	0	07	08	9.1	9.2

THE TYPE OF THE NUT [N]

	ZAMAK 5	Polyamide	Steel	Stainless steel	
				304	316
Nut without grounding	11	12	13	14	15
Nut with grounding	21	-	23	24	25

Type of the material of the insert	INSERTS AVAILABLE											
	D3	D5	T8	T9	KW 8	S	HEX8	HEX10	M11	M12	M2	M3
ZAMAK 5	●	●	●	●	●	●	●	●				
Polyamide	●	●	-	●	●	●	-	-	***	***	***	***
Stainless steel	304	●	●	●	●	●	-	-				
	316	●	●	●	●	●	-	-				

* Possibility to order in another dimension

** Lock for special request.

*** Precise description of inserts M1, M2, M3, check pg. 2A-10

**** applies only to the body

How to order:

Type of lock

Type of body

Type of insert

Type of cam

IP65/IP66** class

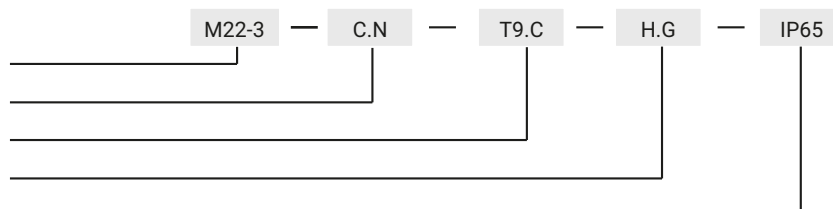

where C,N, G stand for:

C - type of the material and finishing of the surface

N - type of nut

H.G - the cam unbending dimension to be chosen from pages 1C-9 to 1C-22

Notice:

Lock M22-3 is compatible with all cams from range : 11, 12, 13, 14, 18, 31, 32, 33, 34, 38, JZ-002, JK-1610

Butterfly knobs for M22-3 lock

Type M11/M12

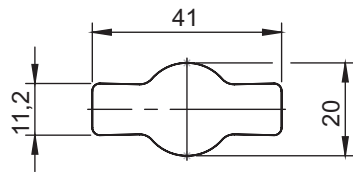

Type M11/M12

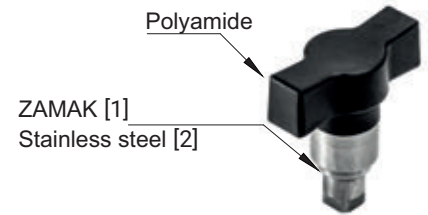

Type M2

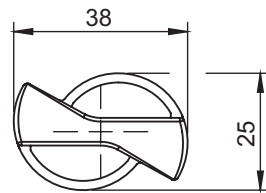

Type M2



Type M3

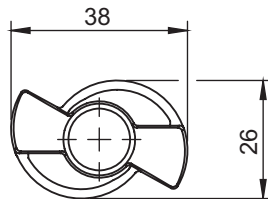

Type M3

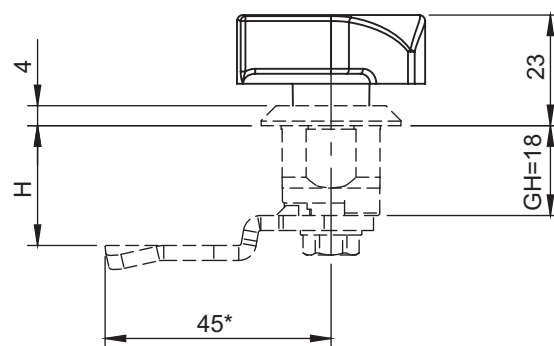

M11, M12, M2 and M3 butterfly knobs are compatible with M22-3 lock - page 2A-9

TYPE	Material		Knob finish [D]	
	Insert	Knob	RAL 9005	RAL 7035
M11	ZAMAK	Polyamide	07	08
M12	Stainless steel	Polyamide		
M2	Polyamide	Polyamide		
M3	ZAMAK	Polyamide		

IP65

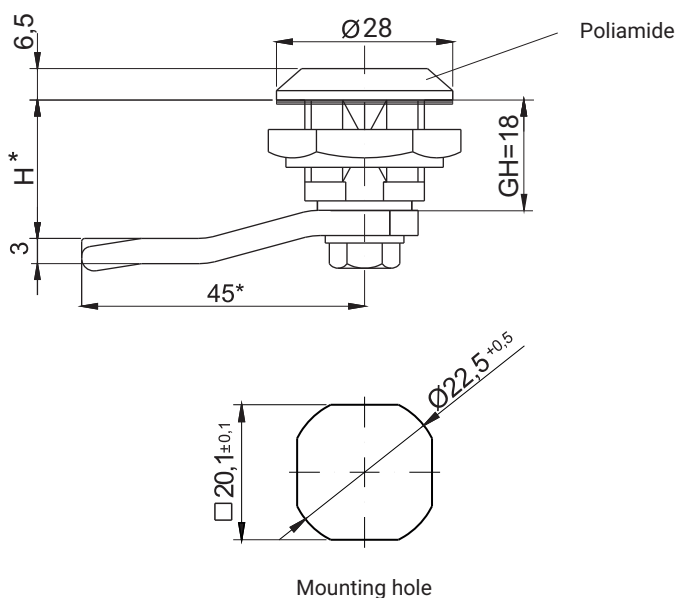

TYPE OF MATERIAL AND PROTECTIVE COATING [C]									
INSERT						HOUSING COLOR[K]			
ZAMAK 5						Polyamide		Polyamide	
Chrome	Nickel	Galvanized	RAL 9005	RAL 7035	No coating	RAL 9005	RAL 7035	RAL 9005	RAL 7035
1	2	3	4	5	0	7	8	7	8
THE TYPE OF THE NUT [N]									
	ZAMAK 5		Polyamide		Steel		Stainless steel		
							304 316		
Nut without grounding		11		12		13		14 15	
Nut with grounding		21		-		23		24 25	

Type of the material of the insert	INSERTS AVAILABLE										
	D3	D5	T8	T9	KW 8	S	N	C9	HEX	T13	T13S
ZAMAK 5	●	●	●	●	●	●	●	●	●	●	●
Polyamide	●	●		-	-	●	-	-	-	-	-

How to order:

- Type of lock
- Type of body
- Type of insert
- Type of cam
- IP65 class

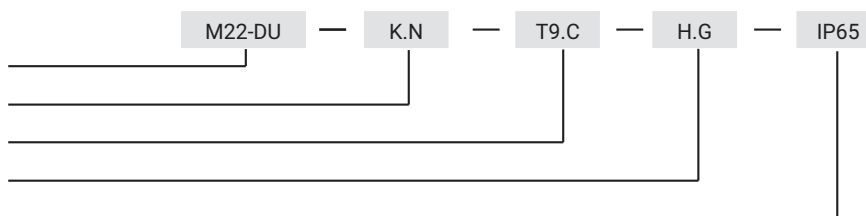

where C,N, G stand for:

- C - type of the material and finishing of the surface
- N - type of nut
- H.G - the cam unbending dimension to be chosen from pages 1C-9 to 1C-22

Notice:

Lock M22-DU is compatible with all cams from range : 11, 12, 13, 14, 18, 31, 32, 33, 34, 38, JZ-002, JK-1610
 Possibility of purchasing the lock with the grounding element.
 The body of the is available only in configuration of polyamide.

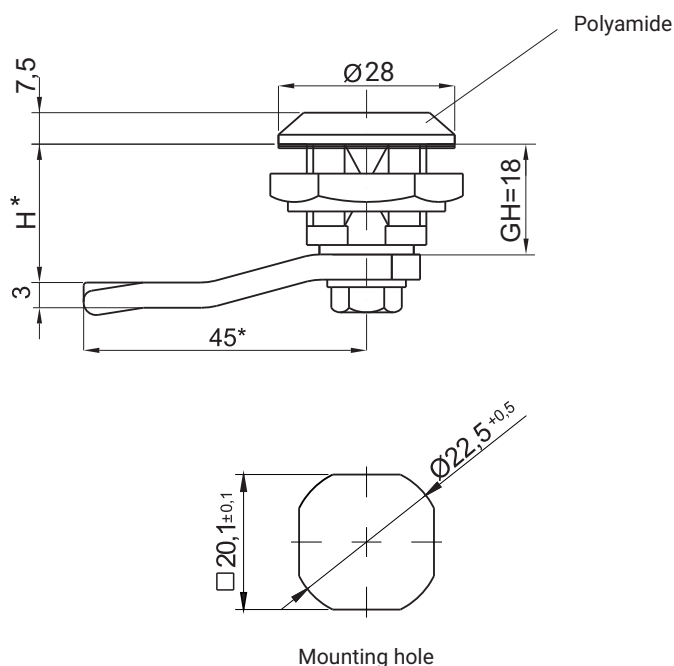

TYPE OF LOCK	COMPONENTS	MATERIAL	FINISH [C]		INSERT
			RAL 9005	RAL 7035	
M22D	Housing, Insert	Polyamide	07	08	 GZ
	Cam	Steel zinc plated	-	-	

The type of the nut [N]					
	ZAMAK 5	Polyamide	Steel	Stainless steel	
				304	316
Nut without grounding	11	12	13	14	15
Nut with grounding	21	-	23	24	25



where C,N, G stand for:

C - type of the material and finishing of the surface

N - type of nut

H.G - the cam unbending dimension to be chosen from pages 1C-9 to 1C-22

Notice:

Lock M22D is compatible with all cams from range: 15, 16, 17, 19, 21, 35, 36, JK, JP

Possibility of purchasing the lock with the grounding element.

The body of the is available only in configuration of polyamide.

IP65

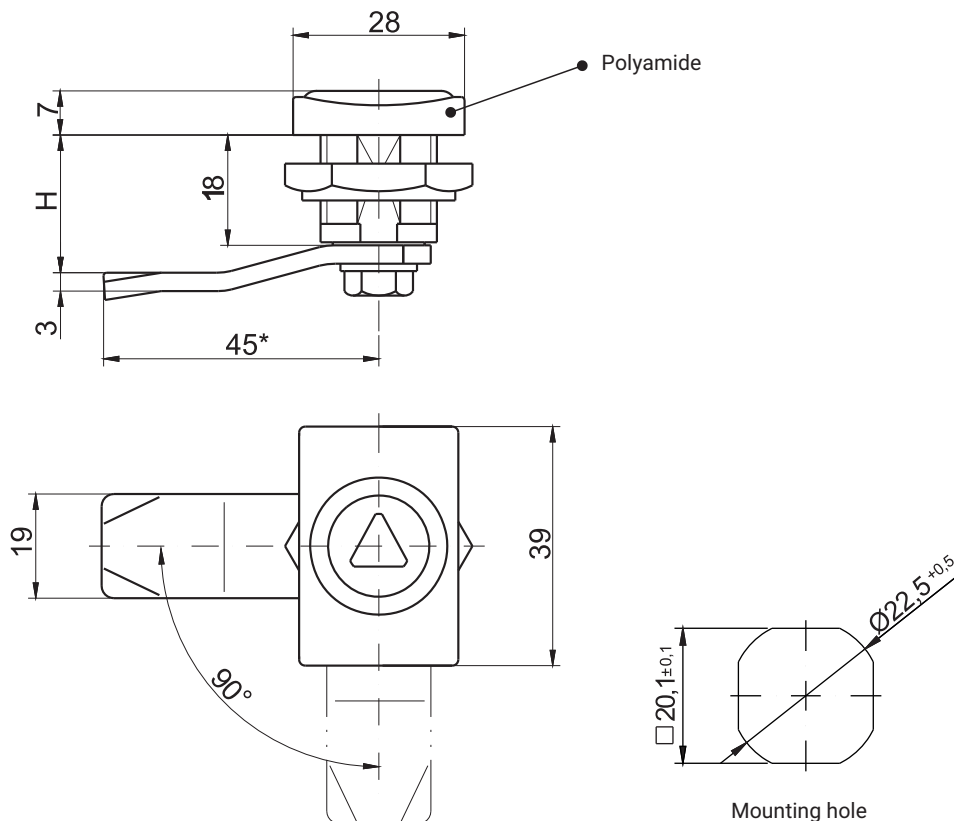

TYPE OF MATERIAL AND PROTECTIVE COATING [C]

INSERT						HOUSING COLOR [K]			
ZAMAK 5						Polyamide		Polyamide	
Chrome 01	Nickel 02	Galvanized 03	RAL 9005 04	RAL 7035 05	No coating 00	RAL 9005 07	RAL 7035 08	RAL 9005 07	7035 08

THE TYPE OF THE NUT [N]

	ZAMAK 5	Polyamide	Steel	Stainless steel	
				304	316
Nut without grounding	11	12	13	14	15
Nut with grounding	21	-	23	24	25

The body of the is available only in configuration of polyamide.

Type of the material of the insert	INSERTS AVAILABLE											
	D3	D5	T8	T9	T10	T11	T13	KW 8	S	N	C9	HEX
ZAMAK 5	●	●	-	●	●	●	●	●	●	●	●	●
Polyamide	●	●	-	-	-	-	-	-	-	-	-	-

How to order:

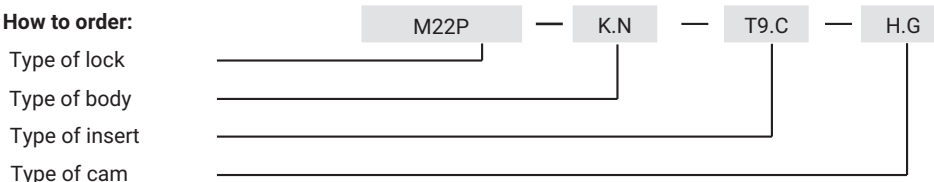

where: C - type of the material and finishing of the surface

N - type of nut

H.G - the cam unbending dimension to be chosen from pages 1C-9 to 1C-22

Notice:

Lock M22P is compatible with all cams from range: 15, 16, 17, 19, 21, 35, 36,

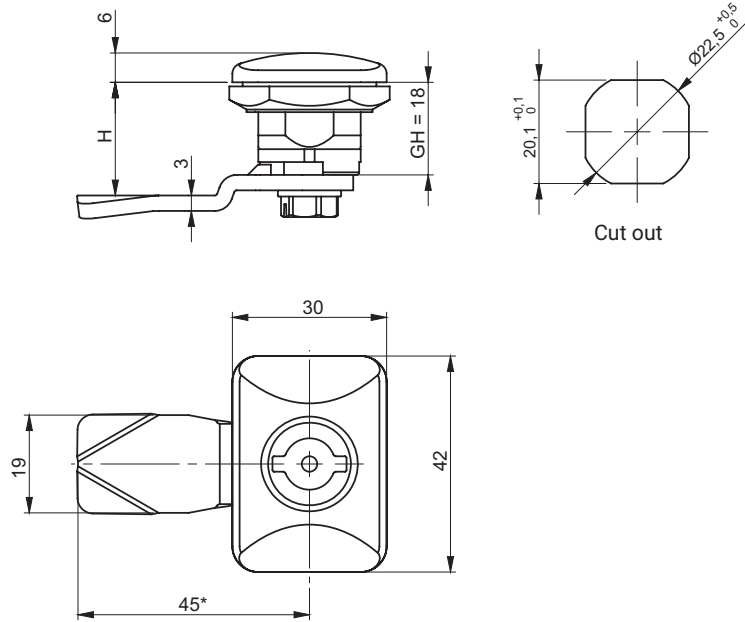

IP66



TYPE OF MATERIAL AND PROTECTIVE COATING OF THE INSERT [C]										HOUSING COLOR [K]	
ZAMAK 5					Polyamide		Stainless steel		Polyamide		
Chrom	Nikiel	O cynk	RAL 9005	RAL 7035	No coating	RAL 9005	RAL 7035	304	316	RAL 9005	RAL 7035
01	02	03	04	05	00	07	08	9.1	9.2	07	08

THE TYPE OF THE NUT [N]					
	ZAMAK 5	Polyamide	Steel	Stainless steel	
				304	316
Nut without grounding	11	12	13	14	15
Nut with grounding	21	-	23	24	25

Type of the material of the insert	INSERTS AVAILABLE							
	D3	D5	T8	T9	KW 8	S	HEX 8 inner	HEX 10 inner
ZAMAK 5	●	●	●	-	●	●	●	●
Polyamide	●	●	-	●	●	●	-	-
Stainless steel	304	●	●	●	●	●	-	-
	316	●	●	●	●	●	-	-

How to order:

- Type of lock
- Type of body
- Type of insert
- Type of cam
- IP class

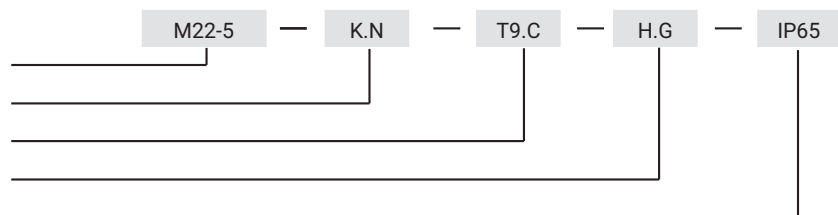

where: C, D - type of the material and finishing of the surface
 N - type of nut
 H.G - the cam unbending dimension (H-locking height, G-group)
 to be chosen from pages 1C-9 to 1C-22

Notice:

Lock M22-5 is compatible with all cams from range: 11, 12, 13, 14, 18, 31, 32, 33, 34, 38, JZ-002, JK-1610

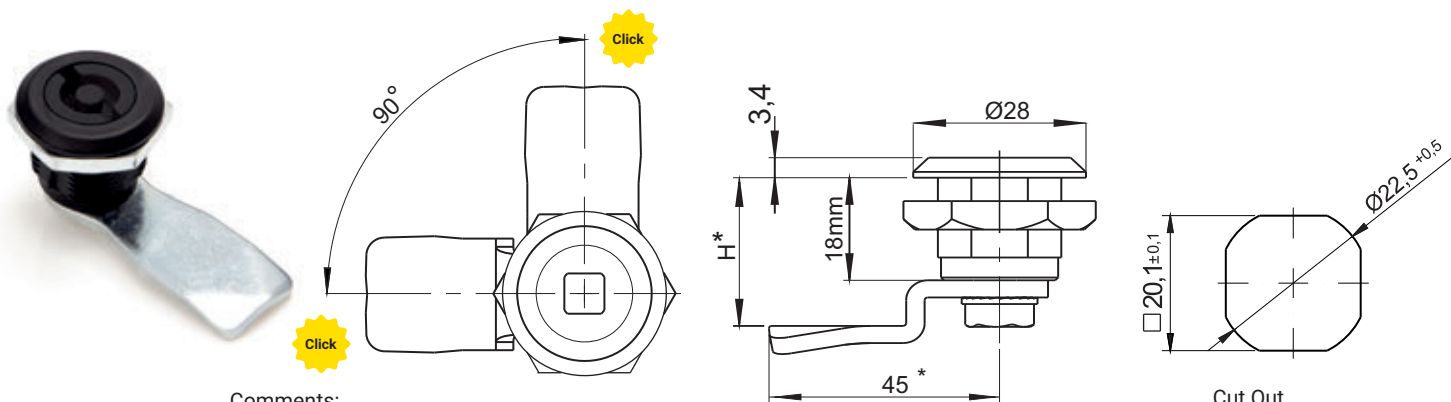

Comments:
Opening and closing the lock is signaled the sound effect

INSERT				INSERT FINISH [C]				HOUSING FINISH [K]	
				Chrome	Nickel	RAL 9005	RAL 7035	RAL 9005	RAL 7035
D5	T9	KW8	KW8 inner	01	02	04	05	07	08
NAME				COMPONENTS				MATERIAL	
Lock M22GP4				Housing				Polyamide	
				Insert				ZAMAK5	
				Cam				Steel zinc plated	

How to order :

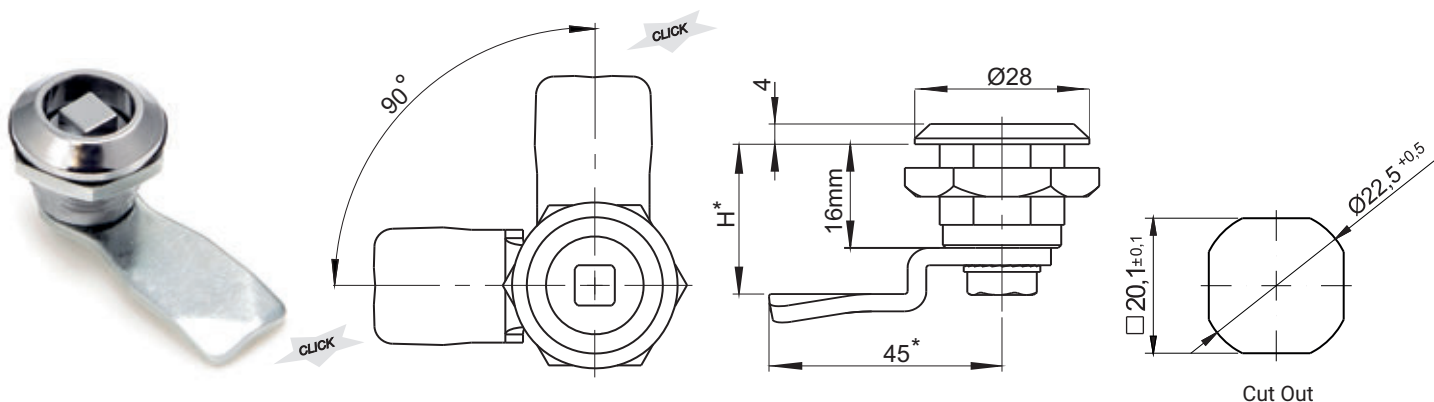
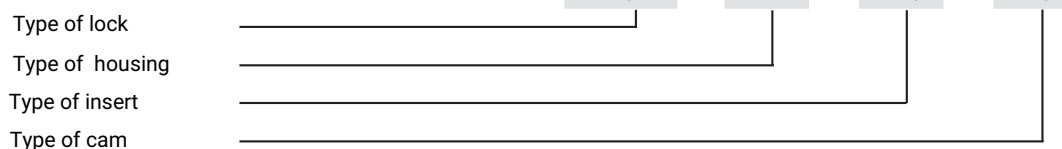

Comments: Opening and closing the lock is signaled the sound effect

INSERT				FINISH [C]					
				Chrome	Nickel	RAL 9005	RAL 7035		
D5	T9	KW8	KW8 inner	01	02	04	05		
NAME				COMPONENTS				MATERIAL	
Lock M22GP5				Housing, insert				ZAMAK5	
				Cam				Steel zinc plated	

How to order :

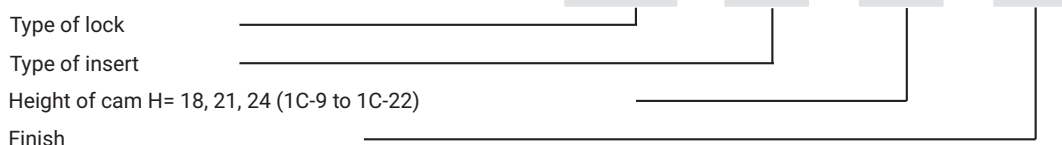

* possibility to make in another dimension

If you order a custom cam, please contact your dealer for further details.

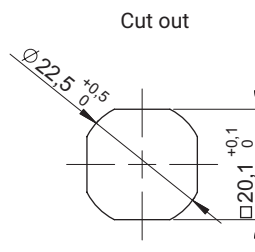
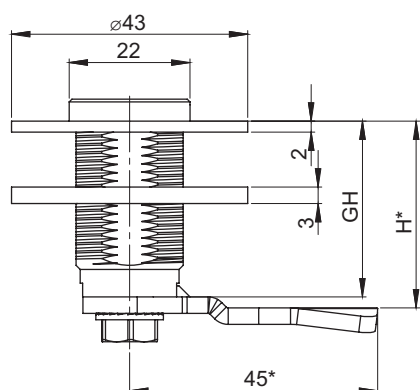

M22KW

M22K / M22K15

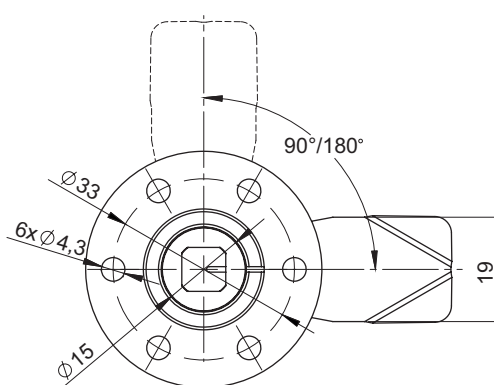
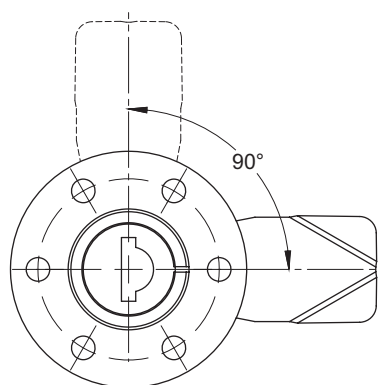

Lock in the left-hand version of the door, right-hand version is a mirror reflection

KEY CODE						
1333	405E	455E	1242E	2342E	RK	
INSERTS				FINISH [C]		
				Chrome	Nickel	RAL 9005
T9	T10	KW 8	S	01	02	04
TYPE OF LOCK	GH	COMPONENTS		MATERIAL		
M22K, M22KW	32	Housing, Insert		ZAMAK5		
		Cam		Zinc plated steel		
M22KSN		Housing, Insert, Cam		Stainless steel		
M22K15	15	Housing, Insert, Cam		Zinc plated steel		
		Housing, Insert, Cam		Stainless steel		

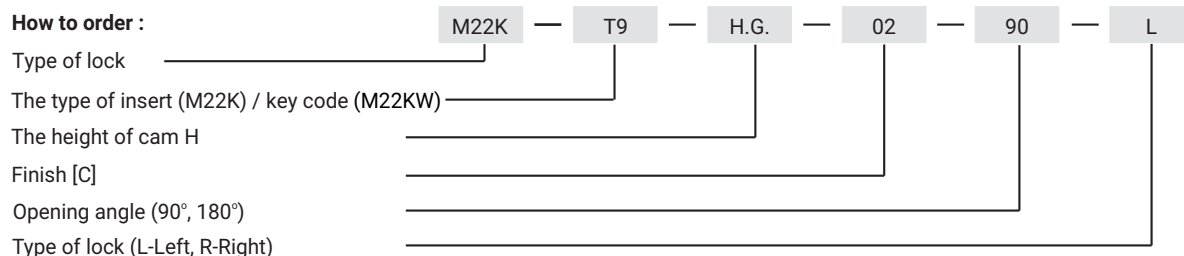

Lock at the height of GH=15mm is available only in a version with shaped insert

The lock is fitted with cams from the group: 12, 14, 21, 32, 34

(pg. 1C-10, 1C-11, 1C-15, 1C-17, 1C-18).

* Possibility to order in a different dimension

IP65

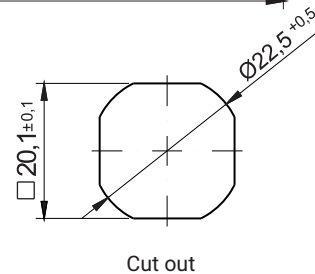
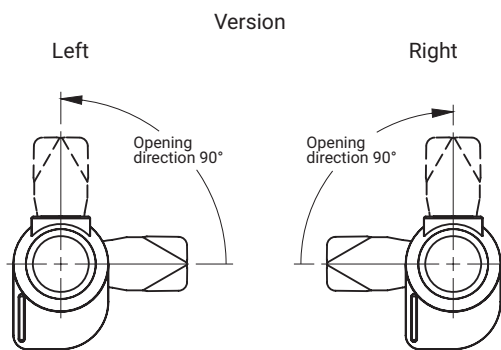
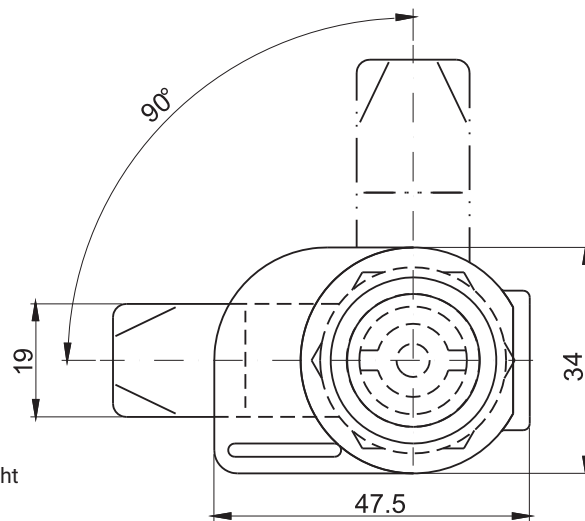
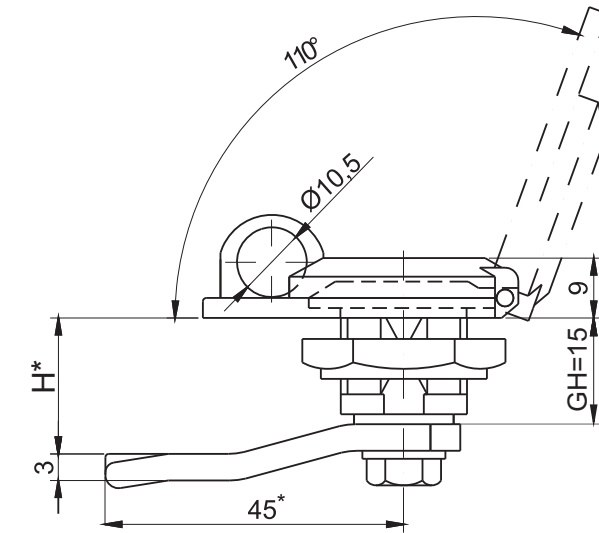

INSERT							FINISH [C]			
							Chrome	Nickel	RAL 9005	RAL 7035
D3	D5	T9	T10	KW 8	S	N	01	02	04	05
NAME		COMPONENTS			MATERIAL					
Lock M22B		Housing, insert			ZAMAK5					
		Cam			Steel zinc plated					
		Blocade			Stainless steel					

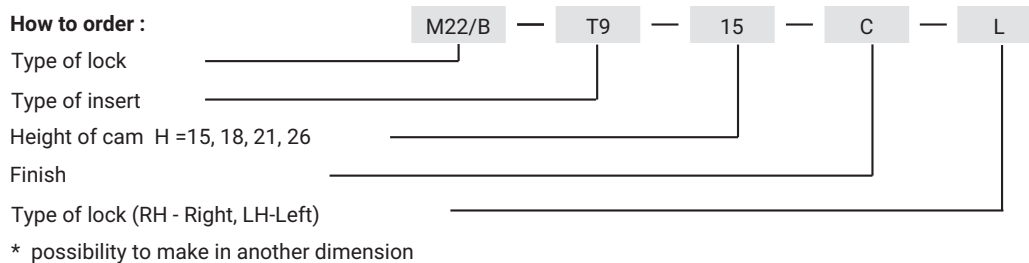

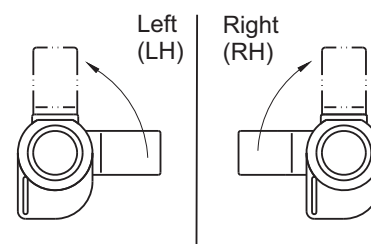
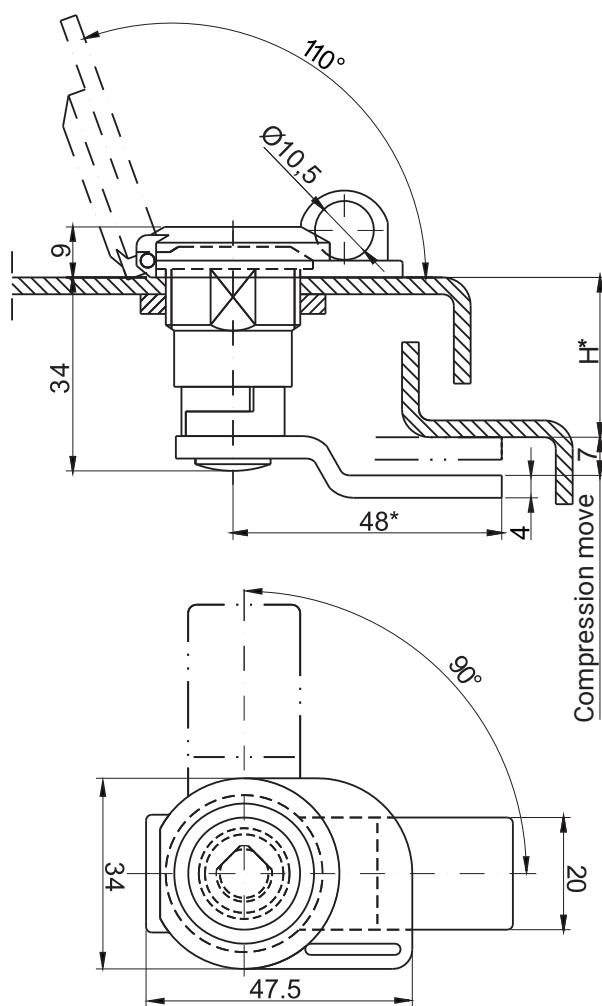

Pic.1 Lock in the closed position. The arrow means the direction opening the lock

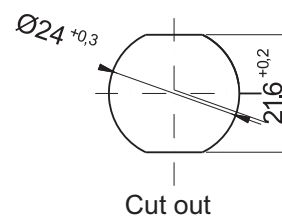

Lock on the drawing in the left door version
The possibility adapting the lock to the door right (Pic.1).

Insert										Finish [C]		
										Nickel	RAL 9005	RAL 7035
T6	T8	T9	L	KW 8	S	N	C9	D3	D5	02	04	05
NAME		COMPONENTS			MATERIAL							
Lock M24B		Housing			ZAMAK5							
		Cam, insert			Steel zinc plated							
		Blocade			Stainless steel							

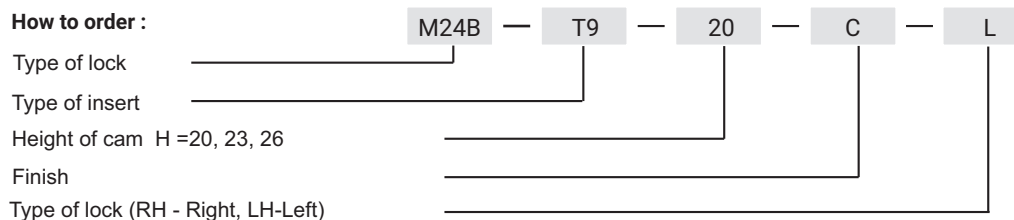

* possibility to make in another dimension

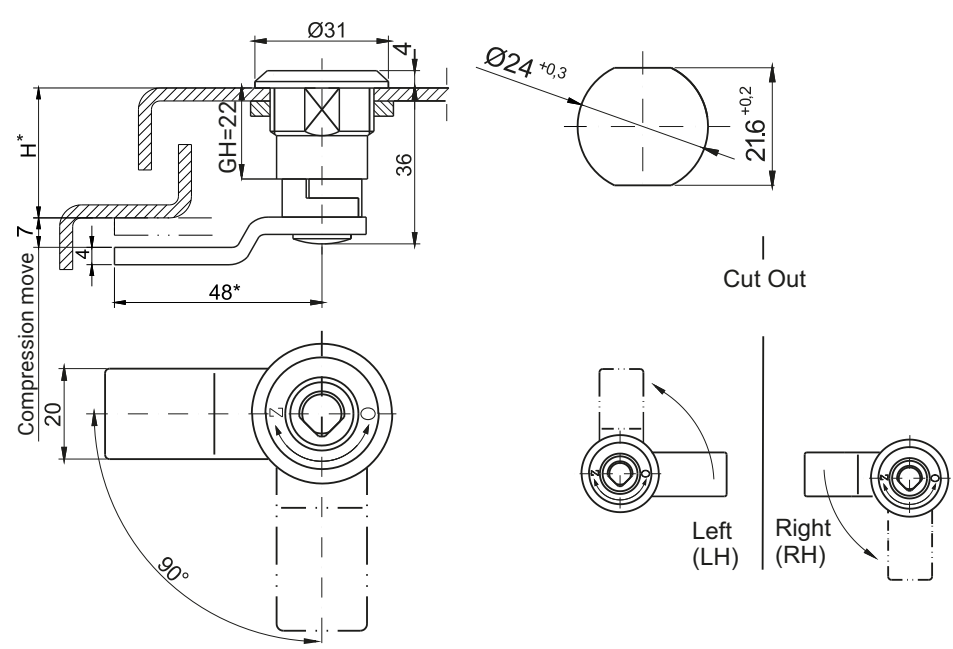

Lock on the drawing in the left door version
The possibility adapting the lock to the door right (Pic.1).

Pic.1 Lock in the closed position.
The arrow means the direction opening the lock

Insert										Finish [C]		
										Nickel	RAL 9005	RAL 7035
T6	T8	T9	L	KW 8	S	N	C9	D3	D5	02	04	05
NAME		COMPONENTS			MATERIAL							
Lock M24		Housing			ZAMAK5							
		Cam, insert			Steel zinc plated							
		Blocade			Stainless steel							

IP65

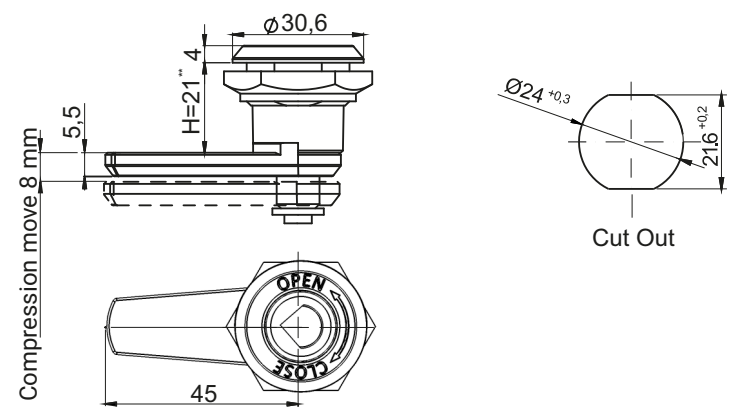

Insert											Finish [C]		
											Nickel	RAL 9005	RAL 7035
T6	T8	T9	T10	L	KW 8	S	N	C9	D3	D5	02	04	05
NAME		COMPONENTS			MATERIAL								
Lock M24ZN		Housing, cam			ZAMAK5								
		Insert			Steel zinc plated								



* possibility to make in another dimension
** lock M24ZN available only with cam dimension H=21 mm

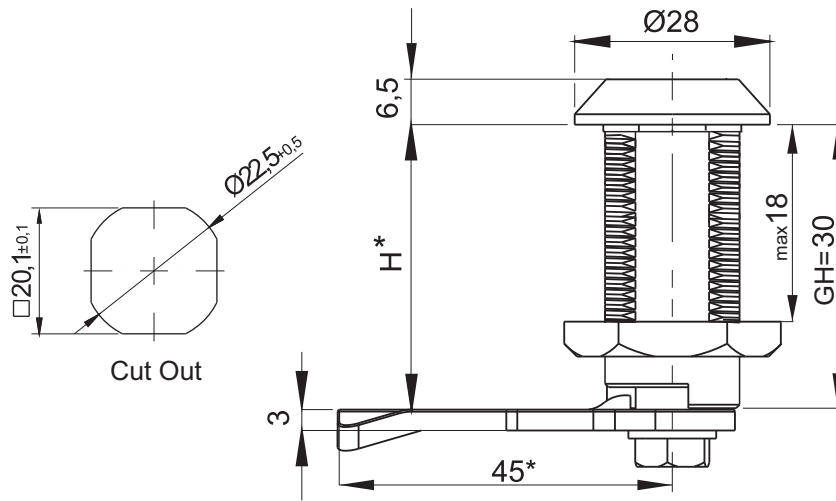

M22-30.02

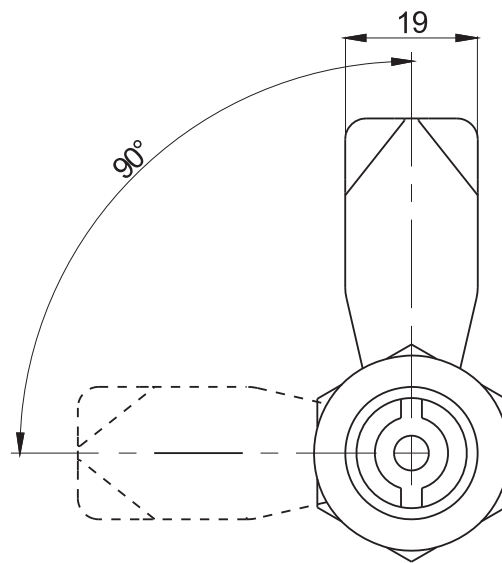

M22-30.01

Additional protection lock is a "Blocade ST1 or ST2 lock" (see page 2A-107, 108, 109)

Insert							Finish [C]			
							Chrome	Nickel	RAL 9005	RAL 7035
D3	D5	T9	KW 8	S	N	C9	01	02	04	05
NAME		COMPONENTS		MATERIAL						
Lock M22-30.01		Housing, insert		ZAMAK5						
Lock M22-30.02		Cam		Steel zinc plated						

How to order :

- Type of lock
- Housing finish
- Type of insert
- Insert finish
- Height of cam H (1C-9 - 1C-22)

M22-30.01 — C — T9 — C — H.G

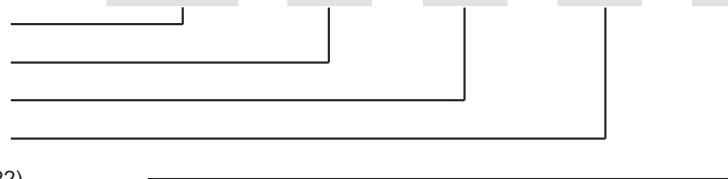

* possibility to make in another dimension
The lock is fitted with cams from the group: 11, 12, 13, 14, 18, 31, 32, 33, 34, 38, JK-1610

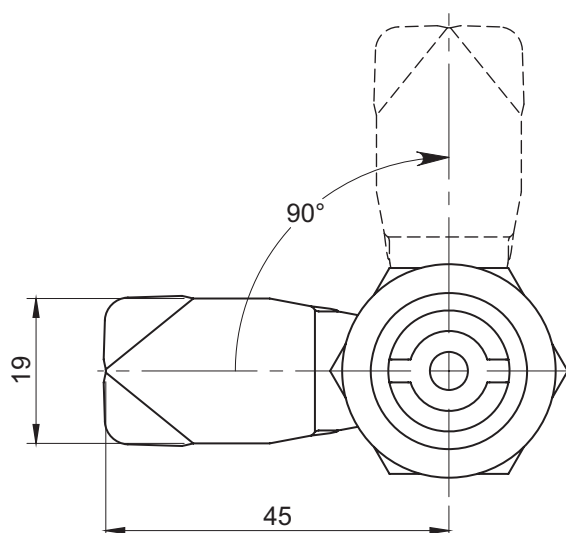
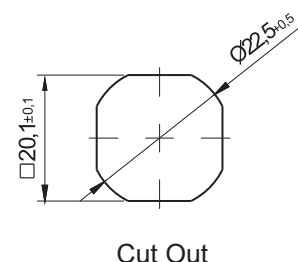
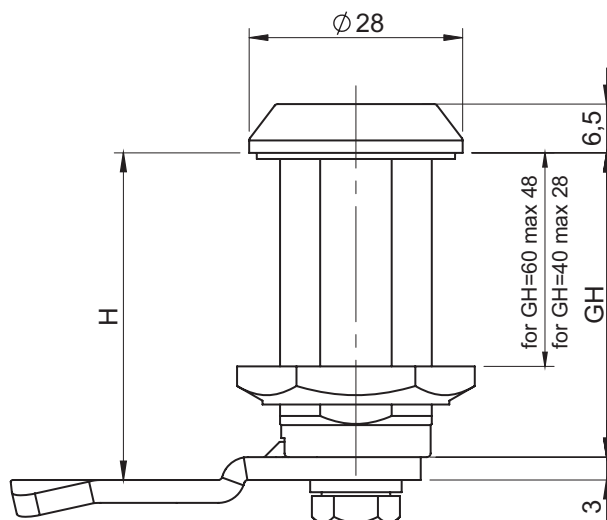

Additional protection lock is a "blocade ST1 or ST2 lock" (see page 2A-107 do 2A-109)

Insert						Finish [C]				
							Chrome	Nickel	RAL 9005	RAL 7035
D3	D5	T9	KW 8	S	N	C9	01	02	04	05
TYPE OF LOCK	DIMENSION GH	COMPONENTS		MATERIAL						
M22-40	40	Housing, insert		ZAMAK5						
		Cam		Steel zinc plated						
M22-60	60	Housing, insert		ZAMAK5						
		Cam		Steel zinc plated						

How to order:

Type of lock

Housing finish

Type of insert

Insert finish

Height of cam H (page 1C-9 - 1C-22)

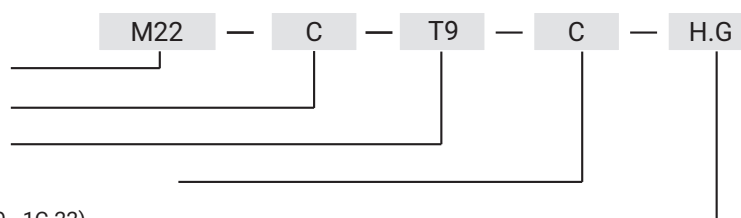

* possibility to make in another dimension

The lock is fitted with cams from the group: 11, 12, 13, 14, 18, 31, 32, 33, 34, 38, JZ-002, JK-1610 (page 1C-9 - 1C-22)

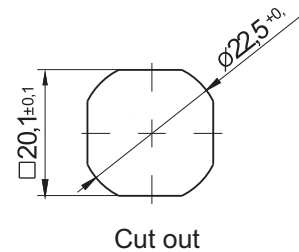
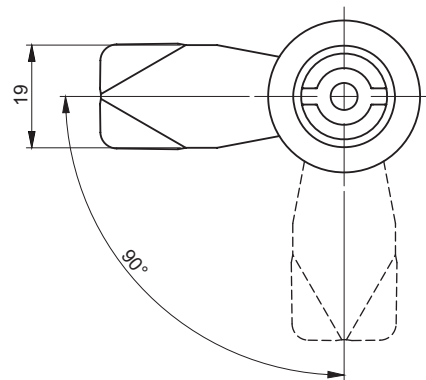
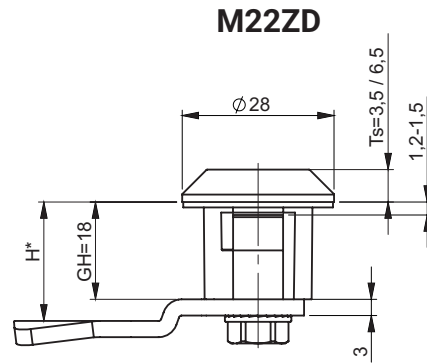

Lock with flange 3.5 version only with pins made of polyamide tip: S, D3, D5.
Locks available from the plastic cam

Insert							Insert finish [C]				Housing finish [K]	
							Chrome	Nickel	RAL 9005	RAL 7035	RAL 9005	RAL 7035
D3	D5	T9	KW 8	S	N	C9	01	02	04	05	07	08
NAME							COMPONENTS				MATERIAL	
M22ZD							Housing				Poliamide	
							Insert				ZAMAK5	
							Cam				Steel zinc plated	

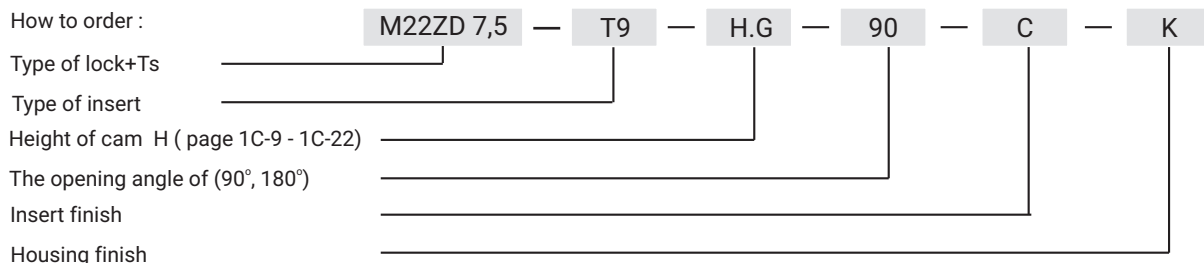

* possibility to make in another dimension
H.G - the cam unbending dimension (H-locking height, G-group)
to be chosen from pages 1C-9 to 1C-22

The lock is fitted with cams from the group: 11, 12, 13, 14, 18, 31, 32, 33, 34, 38, JZ-002, JK-1610.01



M22ZW

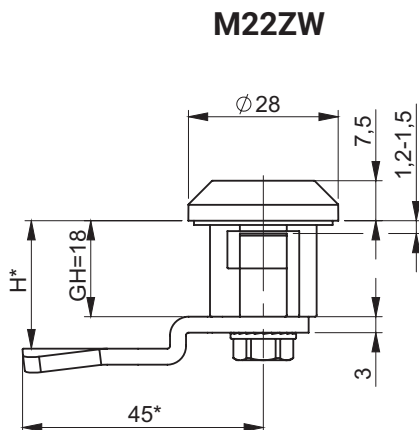

M22ZW22

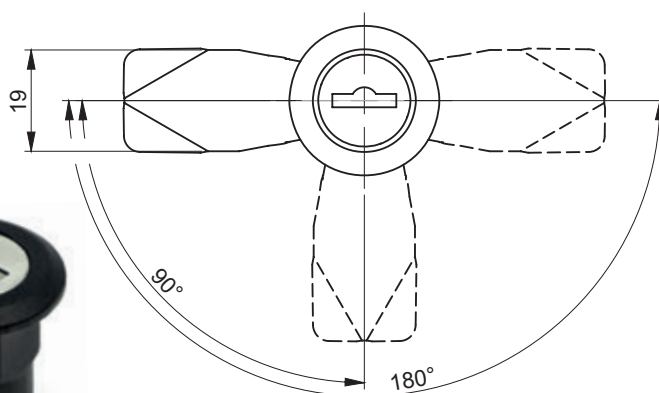
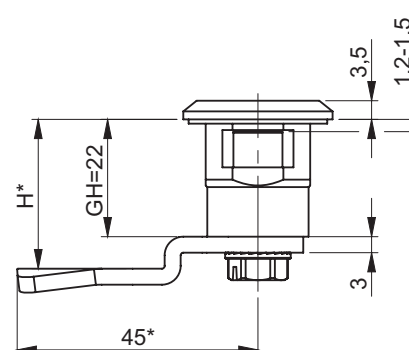

M22ZW22

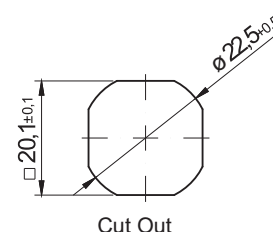

Key code						Finish [C]	
1333	405E	455E	1242E	2432E	RK	RAL 9005	RAL 7035
						07	08
TYPE OF LOCK		COMPONENTS				MATERIAL	
M22ZW		Housing				Poyamide	
M22ZW22		Cam				Steel zinc plated	



* possibility to make in another dimension
H.G - the cam unbending dimension (H-locking height, G-group)

The lock is fitted with cams from the group: 15, 16, 17, 19, 21, JZ-001, JK-10018 (page 1C-9 - 1C-22)

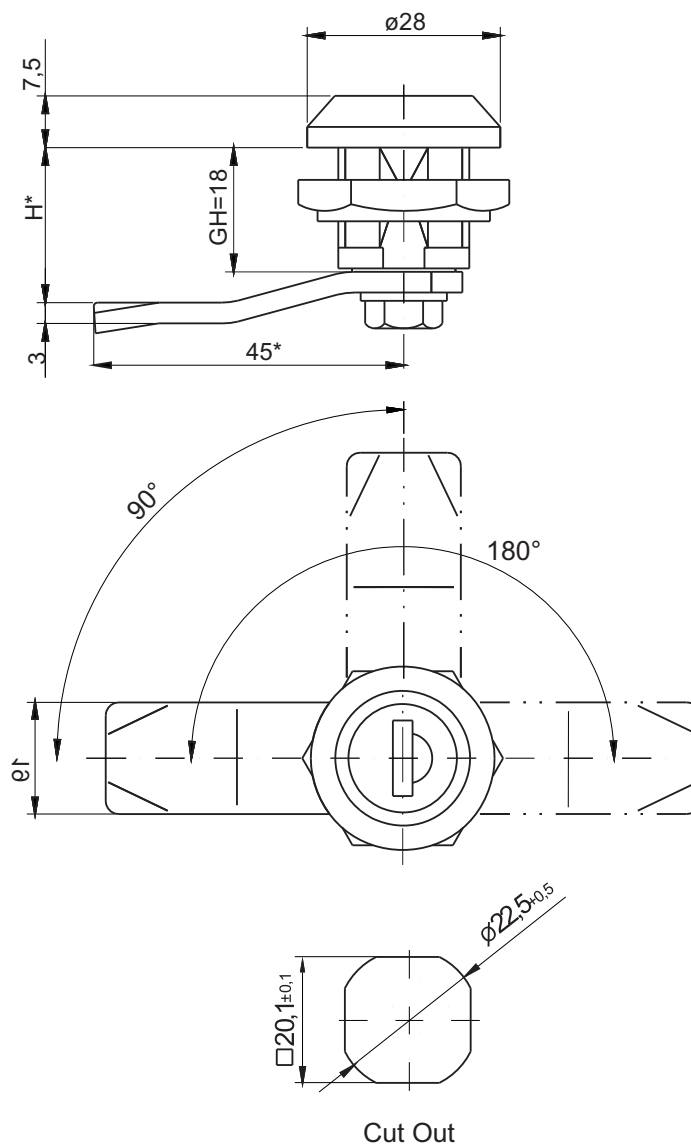

Key code						Finish [C]				
1333	405E	455E	1242E	2432E	RK	Chrome 01	Nickel 02	Zn ** 03	RAL9005 04	RAL7035 05
NAZWA		COMPONENTS				MATERIAL				
Lock M22W		Housing				ZAMAK5				
		Cam				Steel zinc plated				

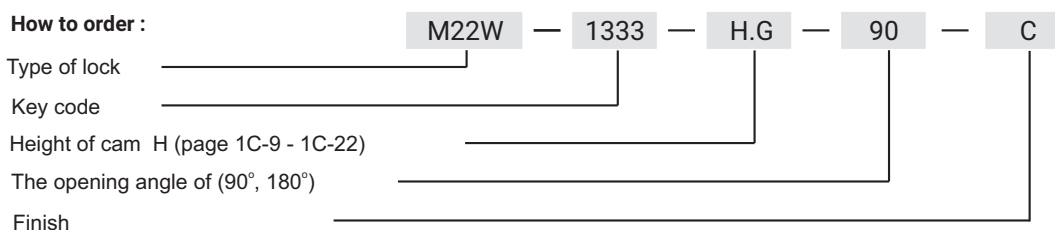

* possibility to make in another dimension

** galvanized

The lock is fitted with cams from the group: 15, 16, 17, 19, 21, 35, 36, JZ-001, JK-10018 (page 1C-9 - 1C-22)

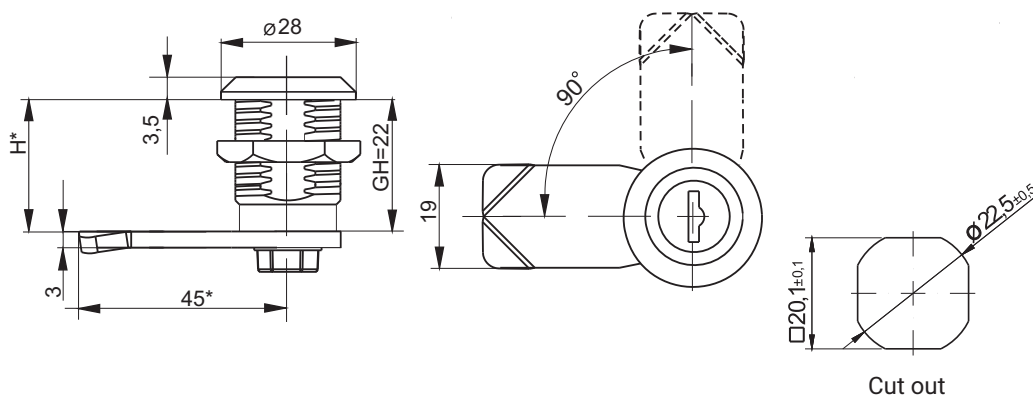

Key code						Finish [C]	
1333	405E	455E	1242E	2432E	RK	RAL 9005	RAL 7035
						07	08
TYPE OF LOCK		COMPONENTS			MATERIAL		
M22DW22		Housing			Polyamide		
		Cam			Steel zinc plated		

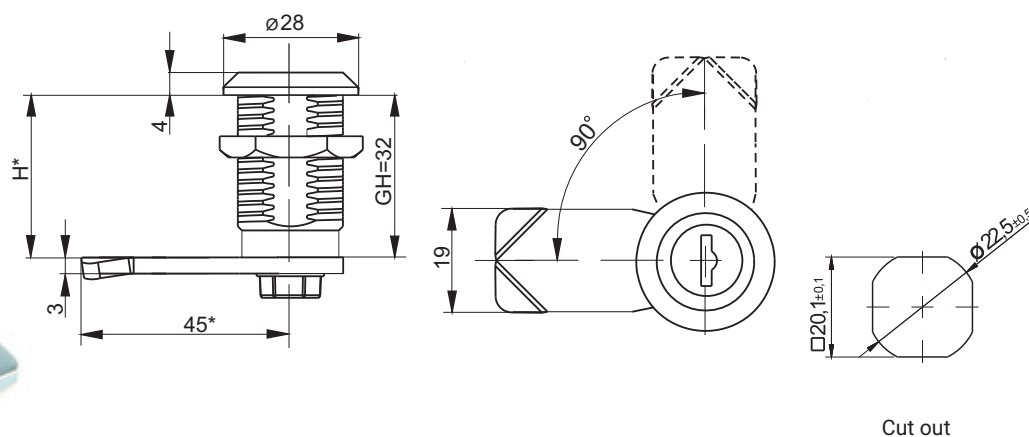

Key code						Finish [C]			
1333	405E	455E	1242E	2432E	RK	Chrome	Nickel	RAL 9005	RAL 7035
						01	02	04	05
TYPE OF LOCK		COMPONENTS			MATERIAL				
M22W32		Housing			ZAMAK5				
		Cam			Steel zinc plated				



* possibility to make in another dimension
 H.G - the cam unbending dimension (H-locking height, G-group)
 The lock is fitted with cams from the group: 15, 16, 17, 19, 21, 35, 36, JZ-001, JK-10018
 (page 1C-9 - 1C-22)

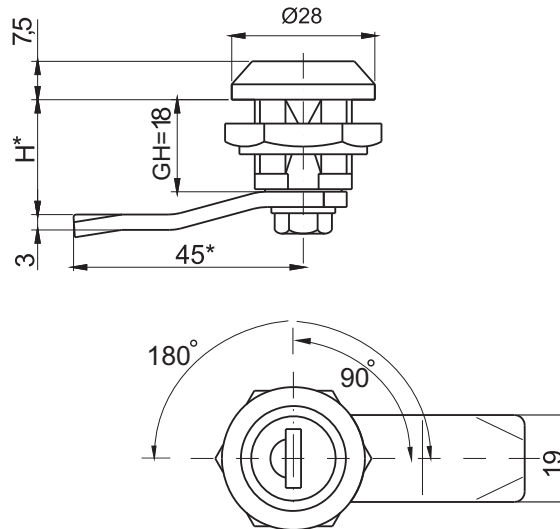

Key code						Finish [C]			
1333	405E	455E	1242E	2432E	RK	RAL 9005	07	RAL 7035	08
TYPE OF LOCK		COMPONENTS				MATERIAL			
M22DW		Housing				Polyamide			
		Cam				Steel zinc plated			

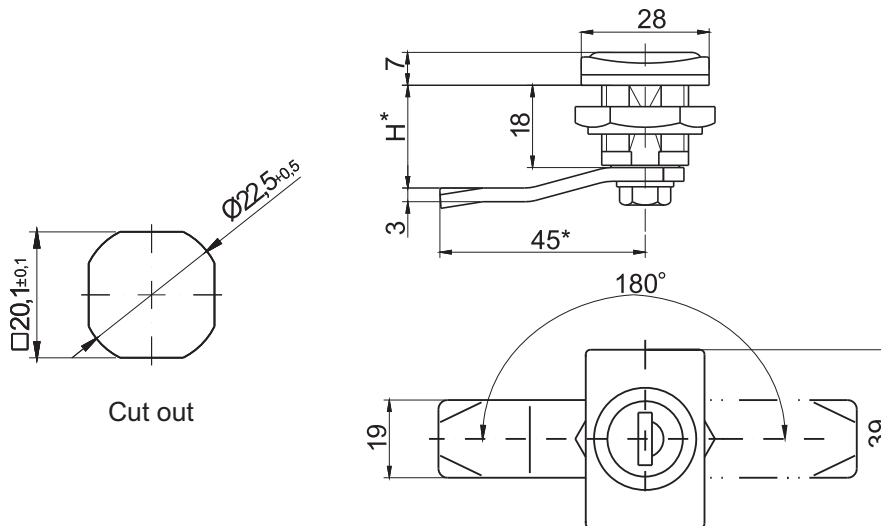

Key code						Finish [C]			
1333	405E	455E	1242E	2432E	RK	RAL 9005	07	RAL 7035	08
TYPE OF LOCK		COMPONENTS				MATERIAL			
M22PW		Housing				Polyamide			
		Cam				Steel zinc plated			

How to order :

M22DW — 1333 — H.G — 90 — C

Type of lock _____

Key code _____

Height of cam H (page 1C-9 - 1C-22) _____

The opening angle of (90°, 180°) _____

Colour of housing _____

* possibility to make in another dimension
 Locks are configured with insert and the nut of polyamide
 H.G - the cam unbending dimension (H-locking height, G-group)
 The lock is fitted with cams from the group: 15, 16, 17, 19, 21, 35, 36, JZ-001, JK-10018 (page 1C-9 - 1C-22)

LH/RH

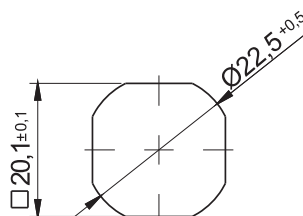
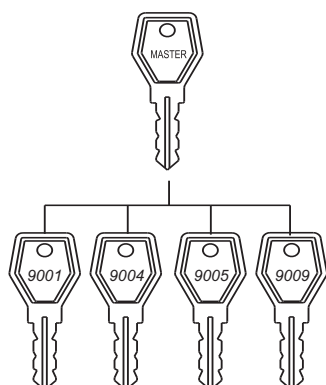
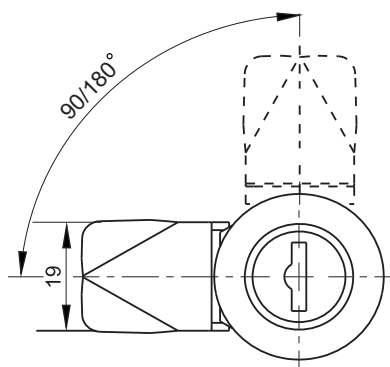
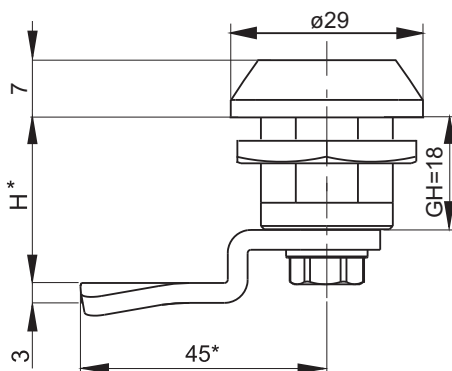

Cut Out

Key code	Finish [C]			
	Chrome	Nickel	RAL 9005	RAL 7035
9001 - 9010	01	02	04	05
NAME	COMPONENTS		MATERIAL	
Lock M22PW	Housing		ZAMAK5	
	Cam		Steel zinc plated	



* possibility to make in another dimension

In order to configure the system master please to contact the dealer.

The lock is fitted with cams from the group: 15, 16, 17, 19, 21, 35, 36, JZ-001, JK-10018 (page 1C-9 - 1C-22)

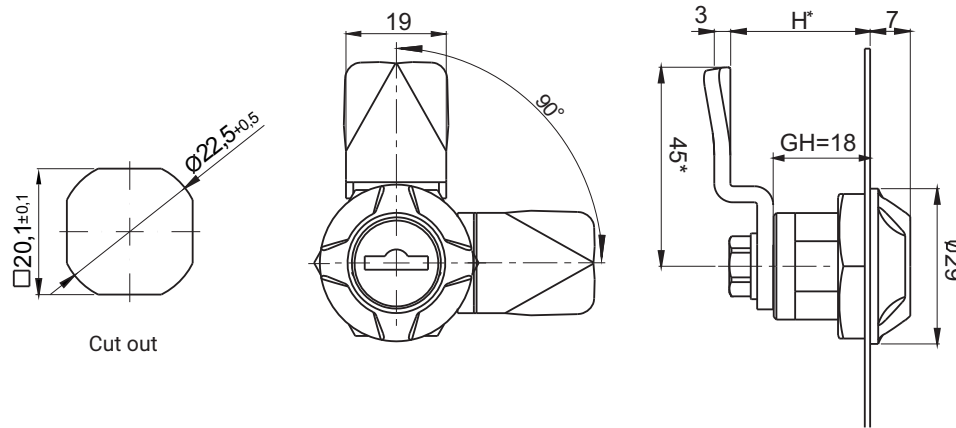

LH/RH



Key code						Finish [C]			
						Chrome	Nickel	RAL 9005	RAL 7035
1333	405E	455E	1242E	2432E	RK	01	02	04	05
NAME		COMPONENTS				MATERIAL			
Lock M22EW		Housing				ZAMAK5			
		Cam				Steel zinc plated			

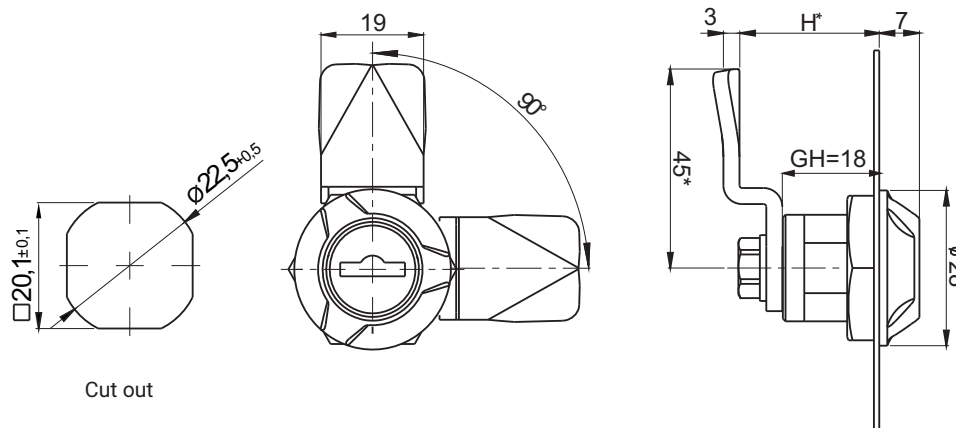

LH/RH



Key code						Finish [C]			
						Chrome	Nickel	RAL 9005	RAL 7035
1333	405E	455E	1242E	2432E	RK	01	02	04	05
NAME		COMPONENTS				MATERIAL			
Lock M22FW		Housing				ZAMAK5			
		Cam				Steel zinc plated			

How to order :

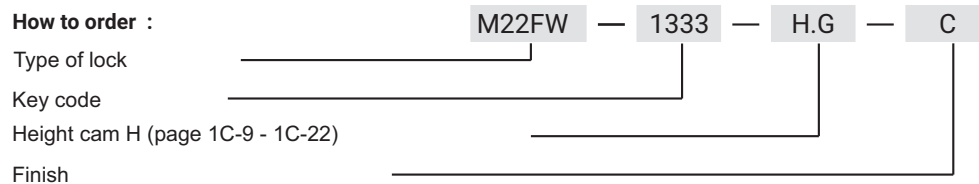

* possibility to make in another dimension

The lock is fitted with cams from the group: 15, 16, 17, 19, 21, 35, 36, JZ-001, JK-10018 (page 1C-9 - 1C-22)

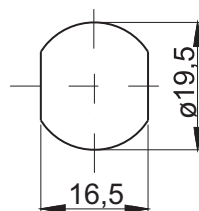
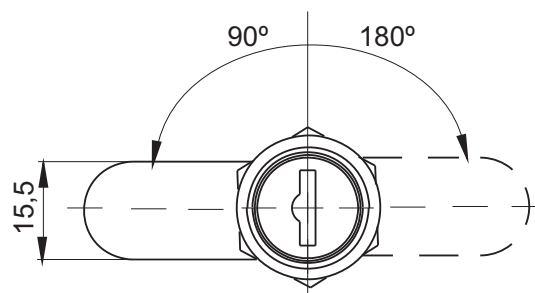
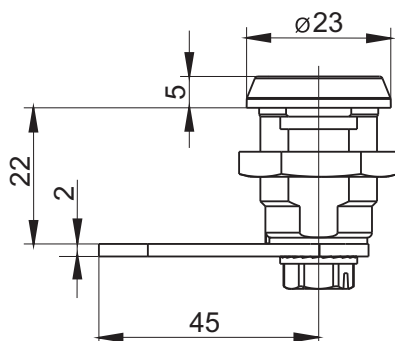

Cut out

Key code						Finish [C]				
						Chrome	Nickel	Zn **	RAL9005	RAL7035
1333	405E	455E	1242E	2432E	RK	01	02	03	04	05
NAME		COMPONENTS				MATERIAL				
Lock M19W		Housing				ZAMAK5				
		Cam				Steel zinc plated				

How to order :

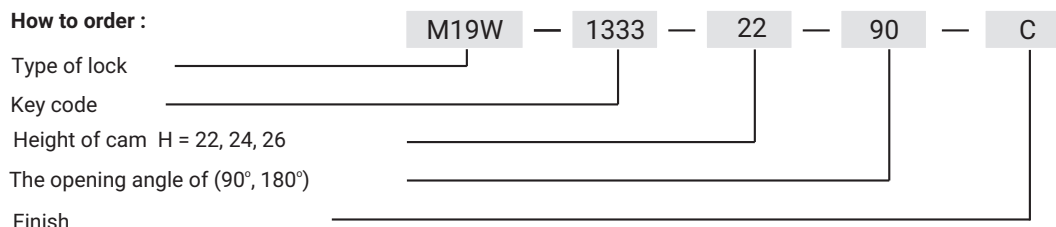

* possibility to make in another dimension
 ** galvanized

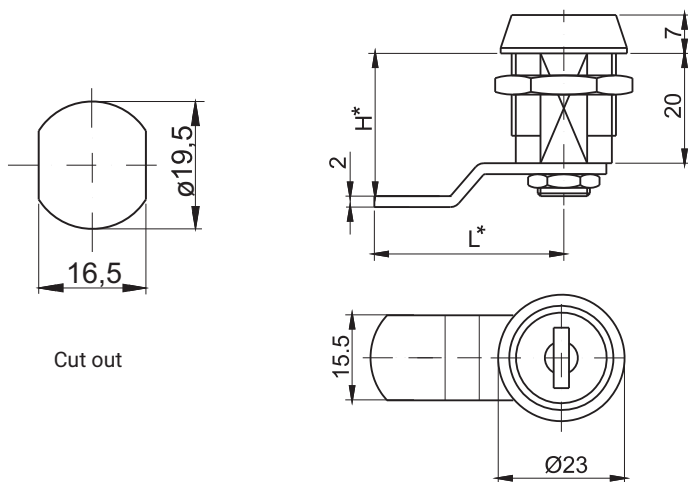

Key code		Finish [C]	
25001	RK	Chrome	
		01	
TYPE OF LOCK		COMPONENTS	MATERIAL
Z-2106		Housing	ZAMAK5
		Cam	Steel zinc plated

How to order :

Z-2106 — RK — 20 — C

Type of lock _____

Key code _____

Height cam H = 20, 22, 26 _____

Finish _____

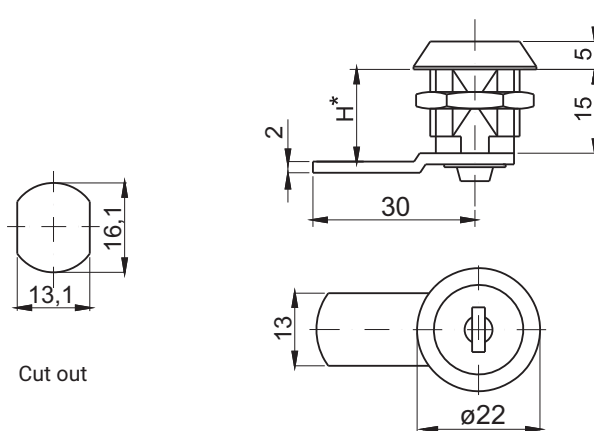

Key code		Finish [C]	
827	RK	Chrome	
		01	
TYPE OF LOCK		COMPONENTS	MATERIAL
Z-0233		Housing	ZAMAK5
		Cam	Steel zinc plated

How to order :

Z-0233 — RK — 15 — C

Type of lock _____

Key code _____

Height cam H = 15, 17 _____

Finish _____

* possibility to make in another dimension

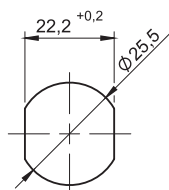

Cut out

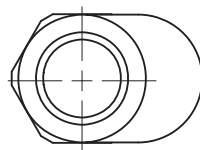
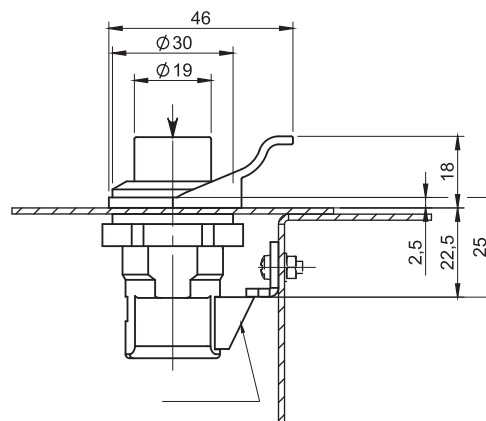
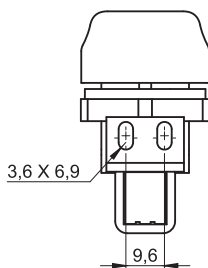

2.529.002

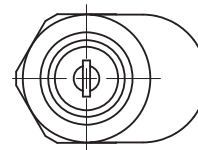

2.529.001

TYPE OF LOCK	VERSION	MATERIAL	FINISH [C]
2.529.001	With key	ABS	RAL 9005
2.529.002	Without key		07

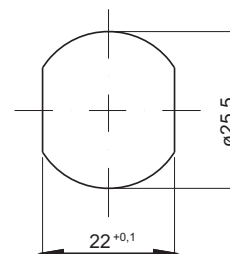
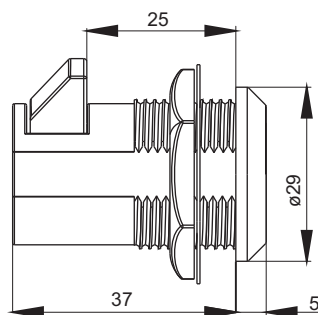
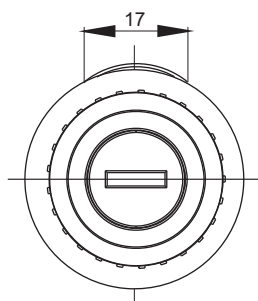

Cut out

TYPE OF LOCK	COMPONENTS	MATERIAL	FINISH [C]
2.611.001	Housing	ZAMAK5	Chrome
			01

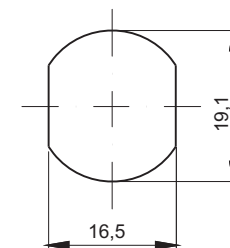
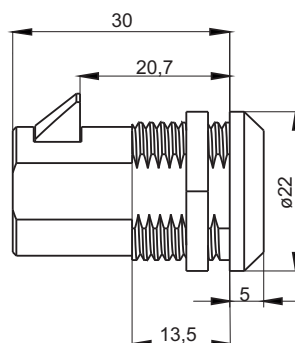
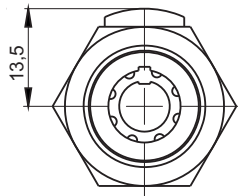

Cut out

TYPE OF LOCK	COMPONENTS	MATERIAL	FINISH [C]
2.612.001	Housing	ZAMAK5	Chrome
			01

stainless steel **IP69K** LH/RH

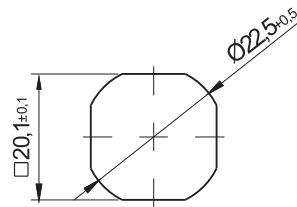
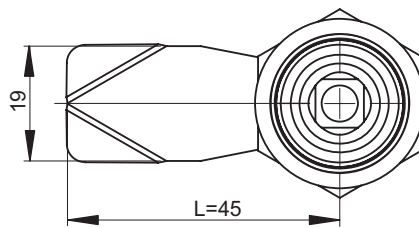
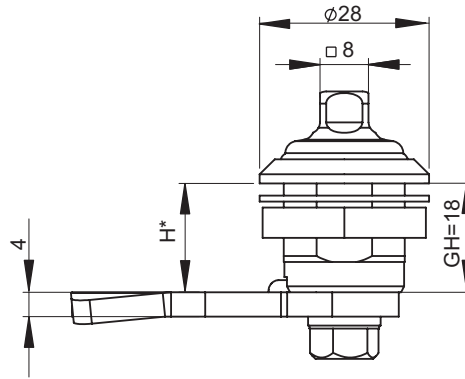

Cut out

The lock have a the IP69K protection
 The seals are in accordance with FDA and have allowing from to come into contact with the food product
 * standard material stainless steel 304, possible to order stainless steel 316

Insert		
T9	KW 8	C9

NAME	COMPONENTS	MATERIAL
Lock M22 IP	Housing, insert	Stainless steel
	Cam	Stainless steel

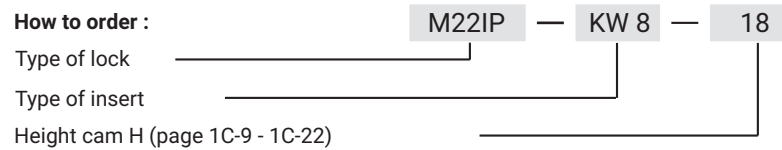

* possibility to make in another dimension

stainless steel

IP65

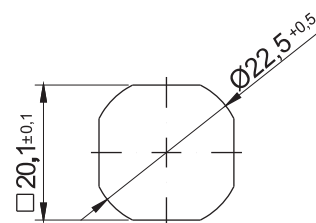
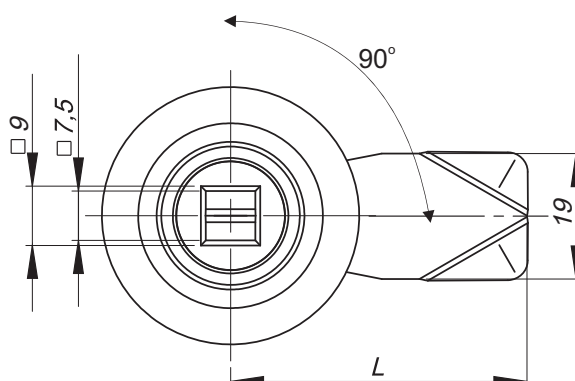
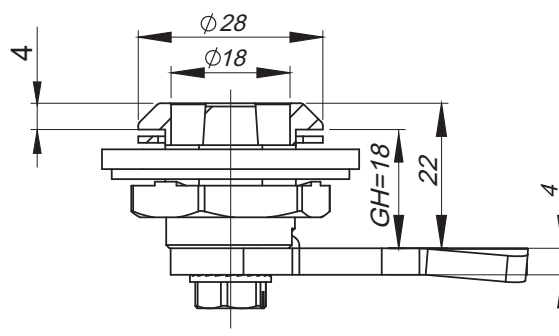

Cut out

The lock in accordance to NF F 01-054 standard.

The lock has a strength test on opening and closing process

and also tests describing the impact of vibration according to EN 61373 standard.

Washer M22 DIN 125 A included.

Inserts



NAME	COMPONENTS	MATERIAL
Lock M22TR	Housing, insert	Stainless steel 304
	Cam	Stainless steel 304

How to order:

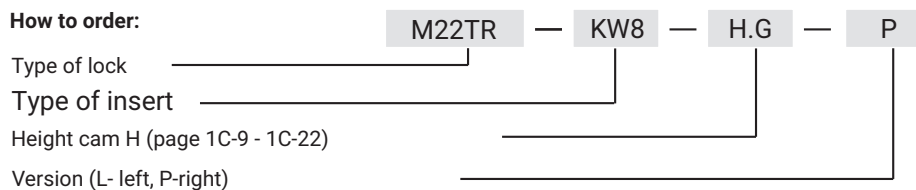

where H.G - the cam unbending dimension

Notice:

Lock M22TR is compatible with all cams from range : 13, 14, 33, 34, H.G dimension to be chosen from pages 1C-9 to 1C-22 from the catalogue.

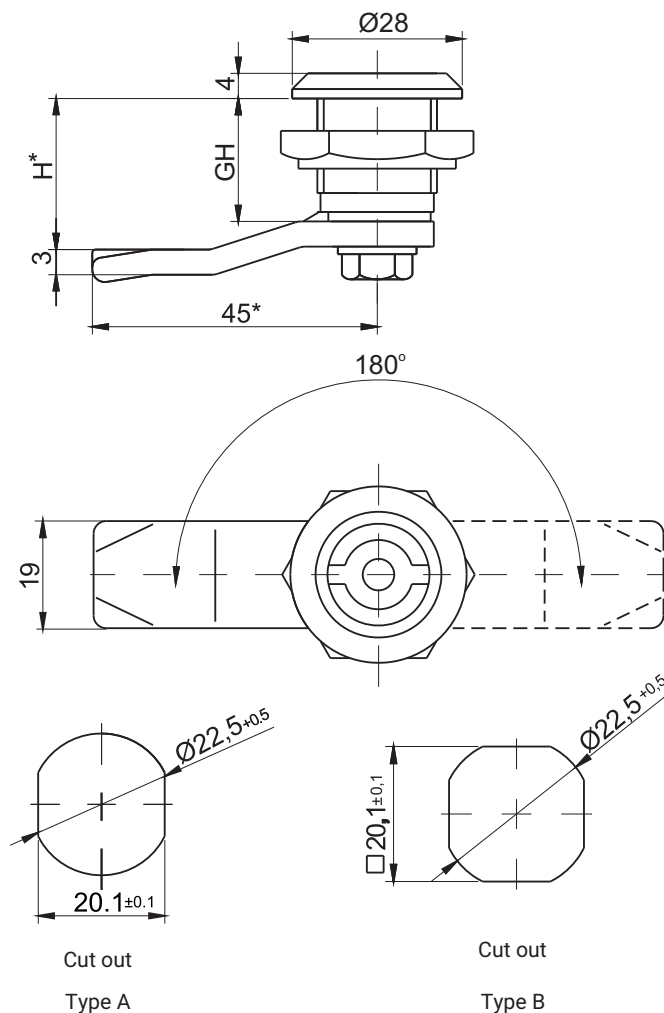

Lock adapted to work with 3 points cam.

Note: Lock milled in with 4 sides (Type B rear lock) - on request.

where:

ZZR18 = GH=18

ZZR19 = GH=19 **ZZR38** = GH=38

ZZR28 = GH=28 **ZZR50** = GH=50

Insert									Finish [C]
									Chrome
D3	D5	T8	T9	KW 8	S	N	C9	KW8-9Z	01
NAME				COMPONENTS				MATERIAL	
ZZR18, ZZR19, ZZR28, ZZR38, ZZR50				Housing, insert				Steel	
				Cam				Steel zinc plated	
ZZR18SN, ZZR19SN, ZZR28SN, ZZR38SN, ZZR50SN				Housing, insert				Stainless steel	
				Cam				Stainless steel	

How to order :

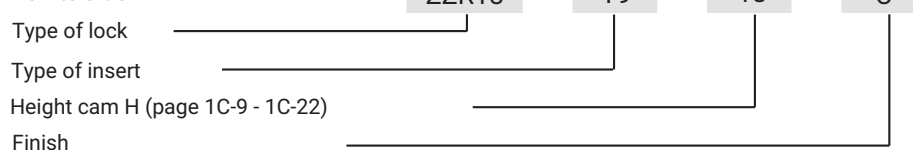

* possibility to make in another dimension

**possibility of making lock grade stainless steel. 316

The lock is fitted with cams from the group: 11, 12, 13, 14, 18, 31, 33, 38, JK-1610.01 (page 1C-9 - 1C-22)

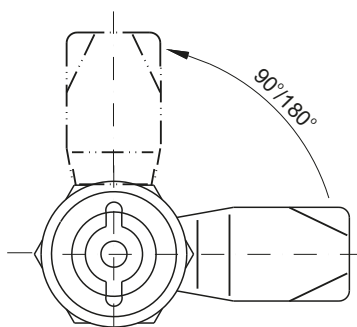
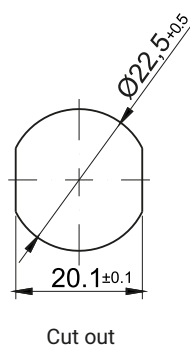
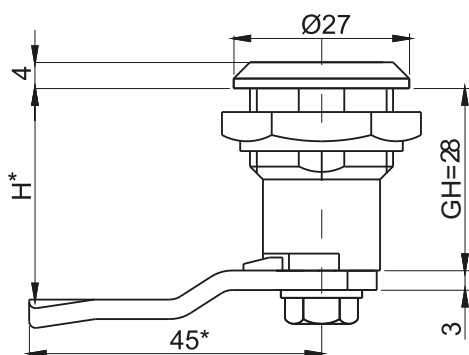
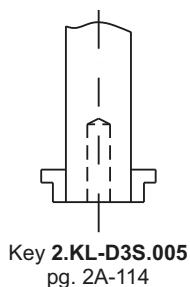

Left version

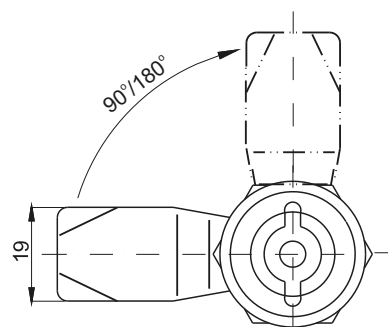

Right version

TYPE OF LOCK	COMPONENTS	MATERIAL	FINISH [C]
			Chrome
ZZR28/S	Housing, insert	Brass	01
	Cam	Steel zinc plated	-
ZZR28/S SN	Housing, insert	Stainless steel	-
	Cam	Stainless steel	-

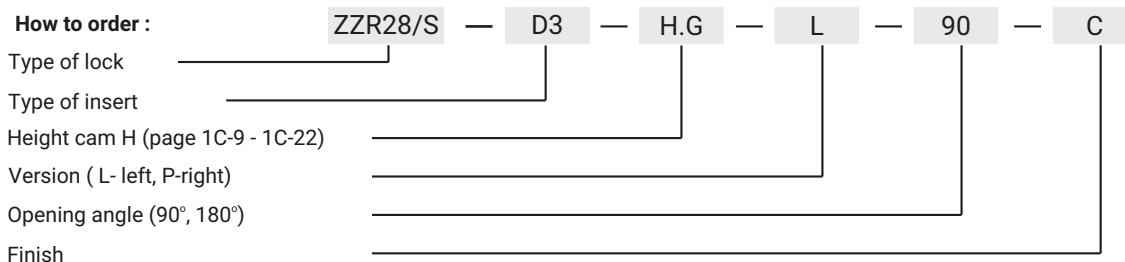

* possibility to make in another dimension

Note:

A key 2.KL-D3S.005 pg.2A-114, can be ordered for the lock, which is designed to prevent the ZZR from being pulled out of the lock when turned to the "open" position.
The lock can be used with 3-point cam with a limiter pg. 1C-17, 1C-18
H.G- dimension of the cam bend (H- height of the lock, G-group)

Lock compatible with cams from groups 11,13,18, 31, 33, 38, JZ-002, JK-1610.01 (pg.1C-9 1C-22).

LH/RH

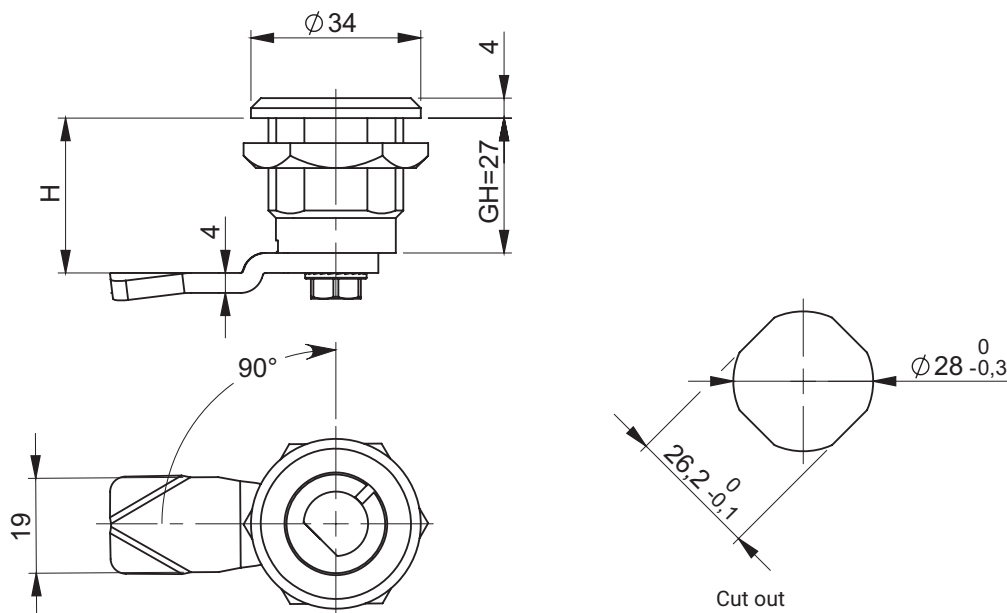

Insert



D13

Note:

1. The key can be inserted and pull out only in the closed position
2. Adapted to lock the key KL-D13 (page 2A-115)

TYPE OF LOCK	COMPONENTS	MATERIAL
CZ-E1	Housing, insert	Brass zinc plated
	Cam	Steel zinc plated

LH/RH

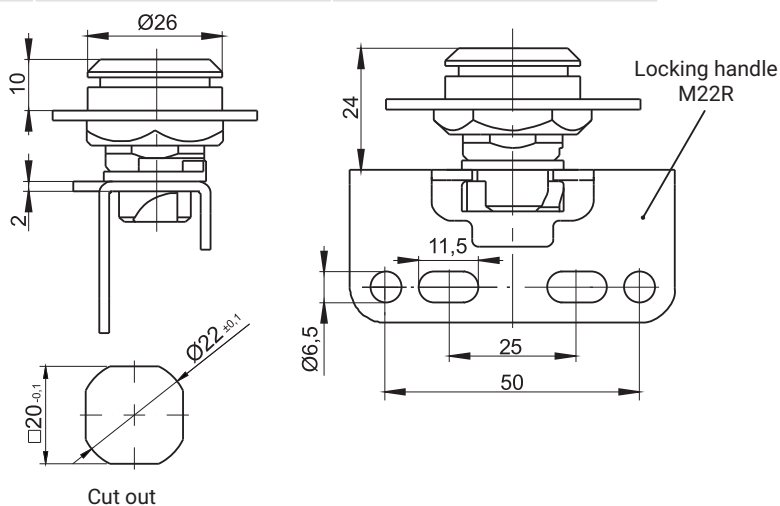
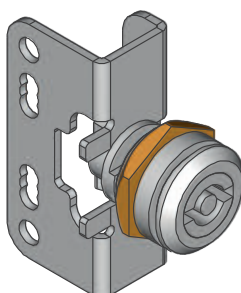

Insert



D5

T9

KW 8

TYPE OF LOCK	COMPONENTS	MATERIAL
M22R	Housing, insert	Steel zinc plated
	Cam	ZAMAK5

How to order :

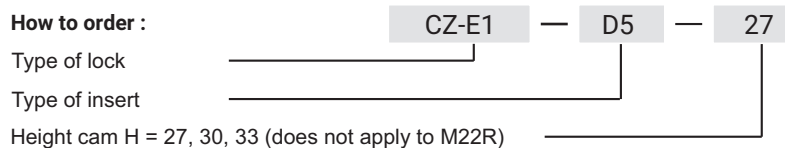

* possibility to make in another dimension

Notice: Handle for M22R is not a part of a set.

To order separately:

- galvanized steel M22R: M22R.001.01
- stainless steel: M22R.001.02

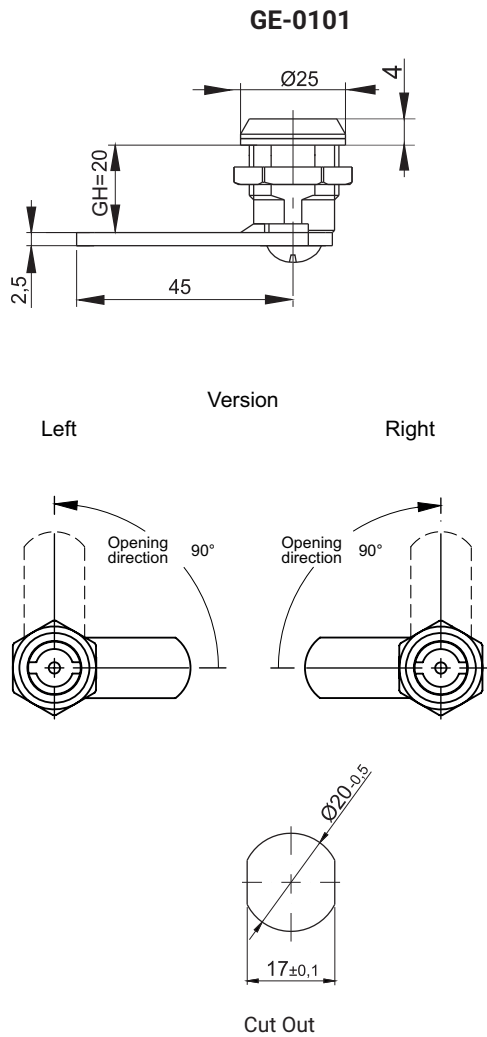

Insert		
D3	T9	KW 8

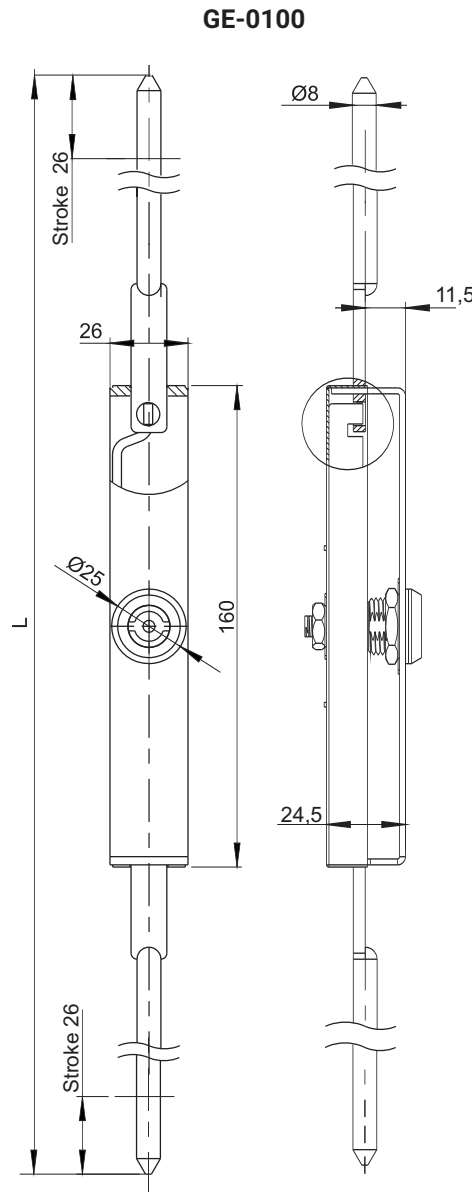

For this lock you can order key from page 2A-112 to 2A-114 (ø13,5)

TYPE OF LOCK	COMPONENTS	MATERIAL	FINISH [C]
			Chrome
GE-0101	Housing, insert	Brass - chromium	01
	Cam	Steel zinc plated	-
GE-0100	Housing, insert	Brass - chromium	01
	Cam	Stainless steel	-

How to order :

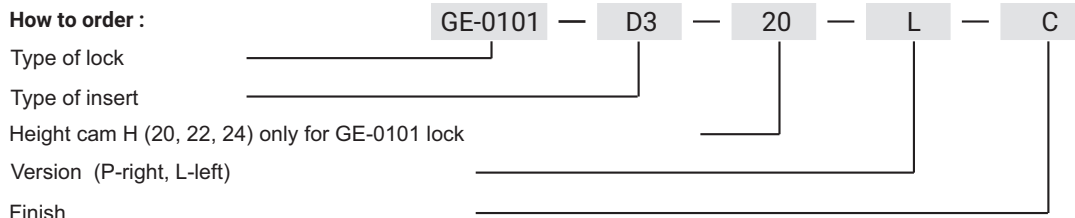

* possibility to make in another dimension

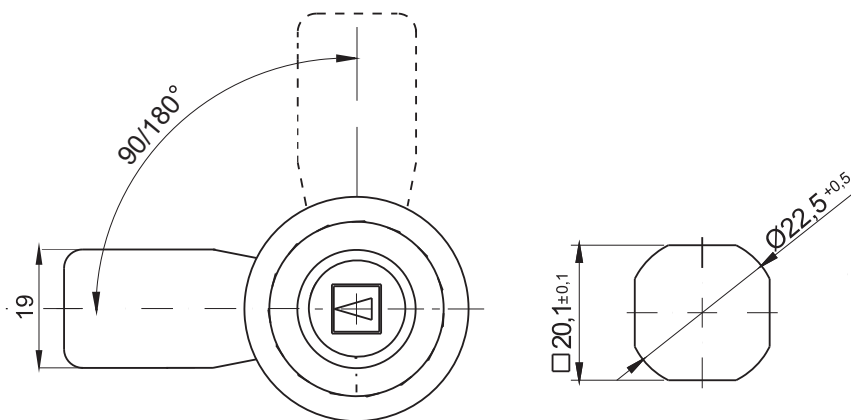
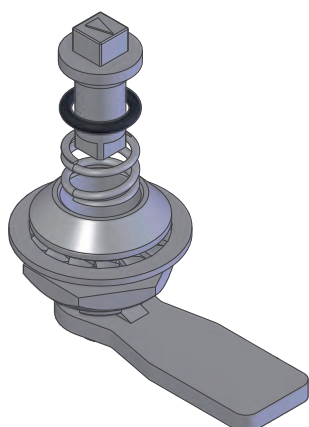
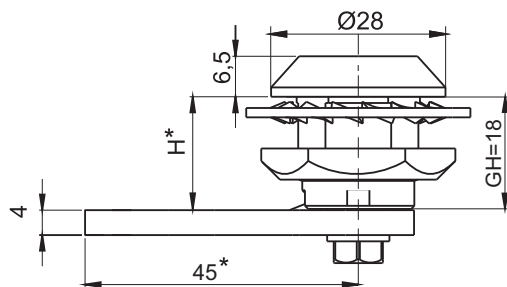

Cut out

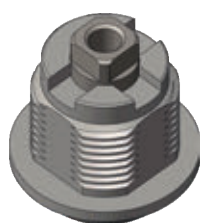

Type A

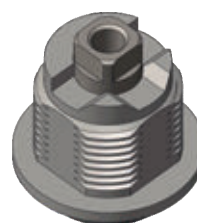

Type B

Lock with backlash compensation and protection in case of accidental opening. In order to open/close the lock first press the insert and then turn 90 degrees.

Insert					Finish [C]			
					Chrome	Nickel	RAL 9005	RAL 7035
KW6	KW8	KW8-3	T8	T9	01	02	04	05
TYPE OF LOCK		COMPONENTS		MATERIAL				
M22SP		Housing, insert		ZAMAK5				
		Cam		Steel zinc plated				

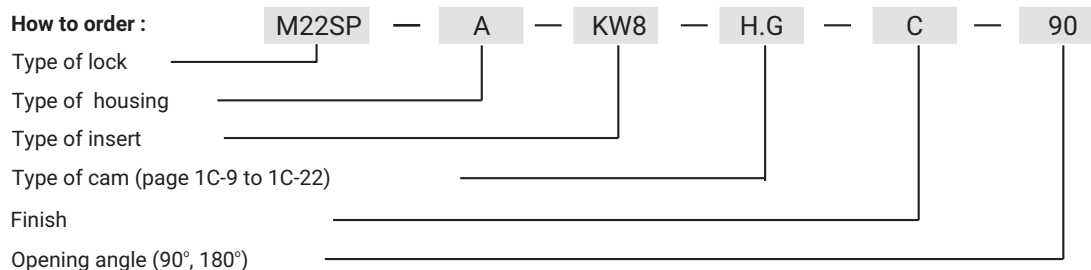

* possibility to make in another dimension

The lock is fitted with cams from the group: 11, 12, 13, 14, 31, 32, 33, 34, 38, (page 1C-9 - 1C-22)

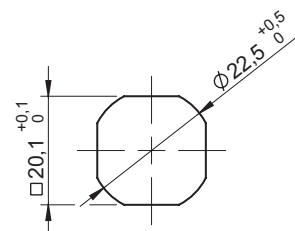
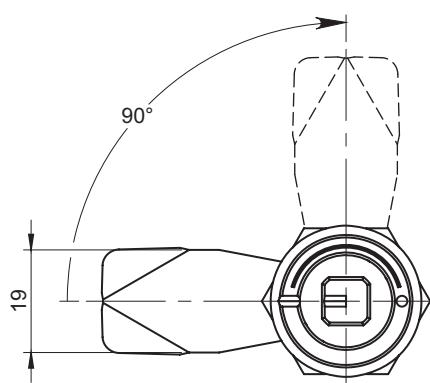
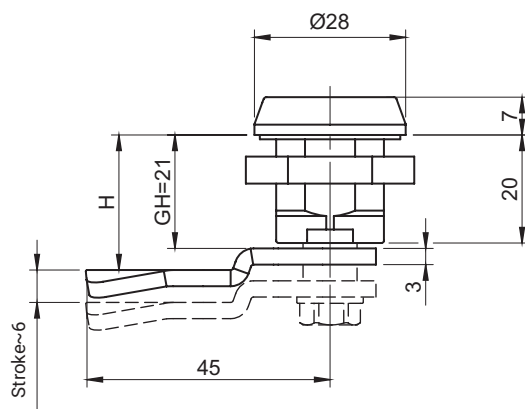

Cut out

Compression lock with a stroke of approx. 6mm.
The drawing shows the right-hand version of the lock.
The left-hand version is a mirror reflection of the right.

TYPE OF LOCK	INSERTS [D]			COMPONENTS	MATERIAL
M22SD20SN				Housing, Insert, Cam	Stainless steel
	RAILWAY	KW8	T9		

How to order:

Type of lock
Type of insert [D]
Locking height
Version (L-left, P-right)

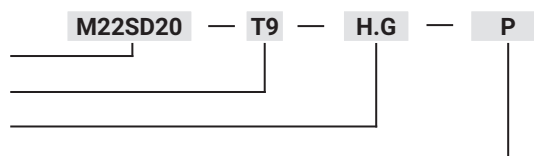

where:

H - locking height
G - cam group

Lock M22SD20SN is fitted with cams from the group: 16 (page 1C-12)

Lock M22SA2 with foamed sealing PUR



LH/RH



IP65

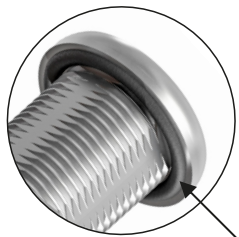
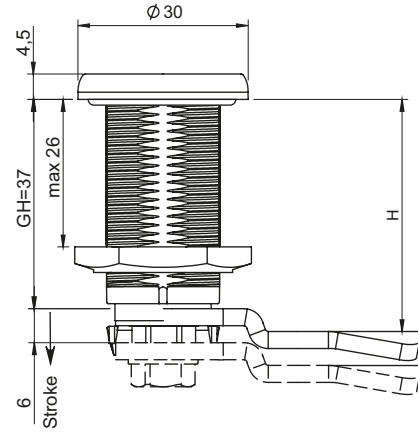

Housing with foamed sealing PUR

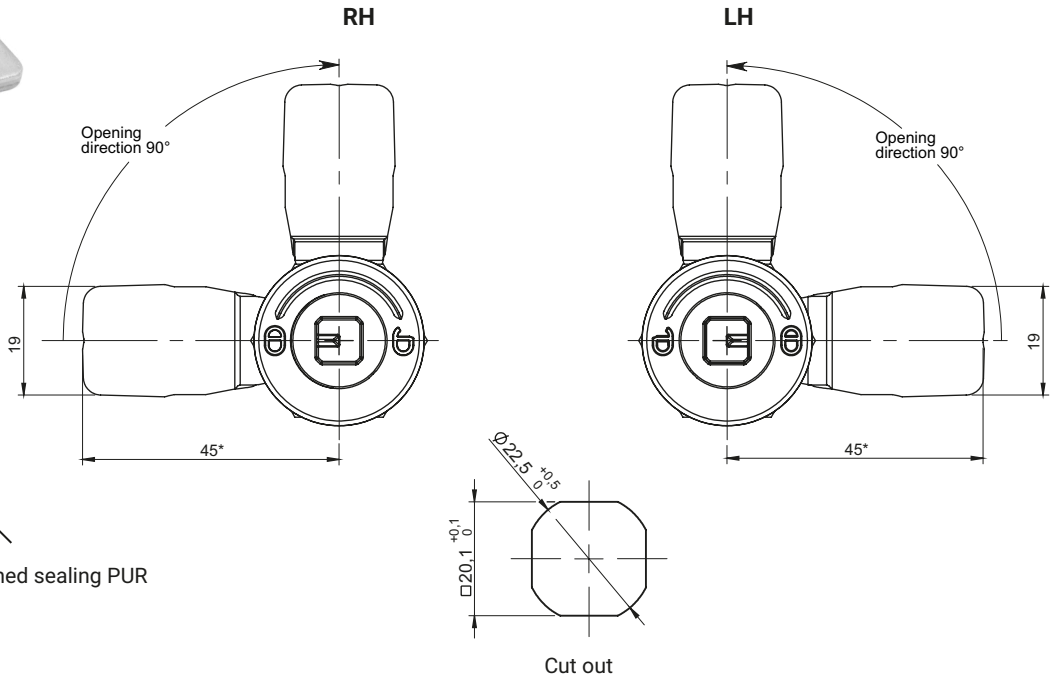

TYPE OF LOCK				COMPONENTS		MATERIAL	
M22SA2				Housing, Knob		ZAMAK5	
				Cam, Washer, Nut Internal mechanism		Steel zinc plated	
INSERTS [X]				FINISH [C]			
				Chrome		RAL9005	
KW8	T8	D3	D5	01	04		

How to order:

- Type of lock
- Type of insert [X]
- Insert finish [C]
- Type of lock (L-Left, R-Right)
- Housing finish [C]
- Locking height
- PUR foam seal

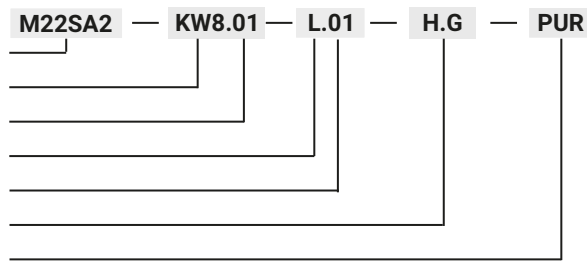

where:

- H - the cam unbending dimension
- G - cam group

Lock M22SA2 is compatible with all cams from range:15, 16, 19, 35, 36 (page 1C-12 - 1C-19)

LH/RH

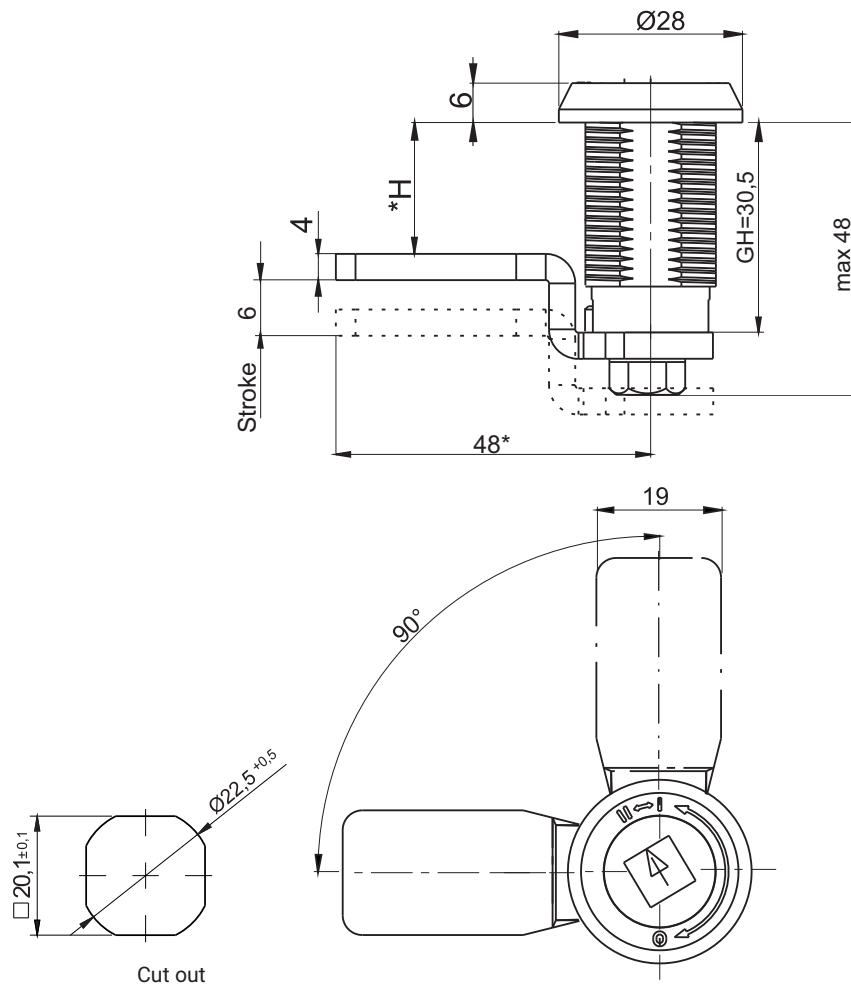

Insert					Finish [C]	
					Chrome	
T9	KW 8	S	N	RAILWAY	01	
TYPE OF LOCK			COMPONENTS		MATERIAL	
M22SD30			Housing, Insert		ZAMAK5	
			Cam		Steel zinc plated	
M22SD30-SN			Housing, Insert, Cam		Stainless steel	

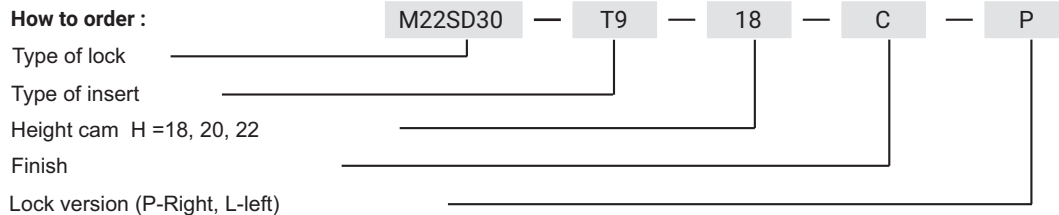

* possibility to make in another dimension
 Lock M22SD30 addition to being locked, has shaped the possibility of additional security padlock.

stainless steel

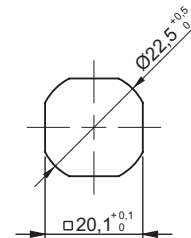
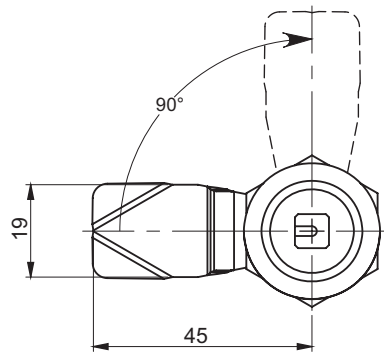
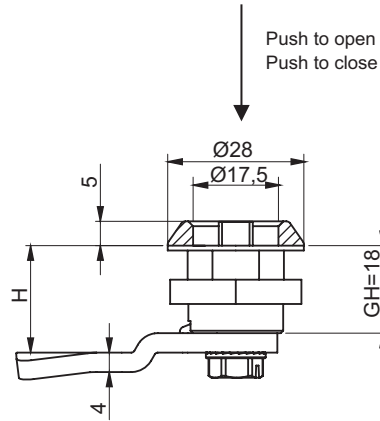

Cut out

Lock with backlash compensation and protection in case of accidental opening. In order to open/close the lock first press the insert and then turn 90° degrees.

Insert			
KW 7	KW 8	T8	T9
TYPE OF LOCK		COMPONENTS	MATERIAL
M22SP2		Housing, Insert, Cam	Stainless steel

How to order:

Type of lock
Type of housing
Finish

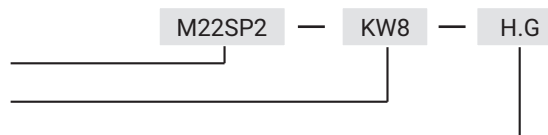

The lock is fitted with cams from the group: 13, 14, 33, 34, (page 1C-9 - 1C-22)

stainless steel **LH/RH**

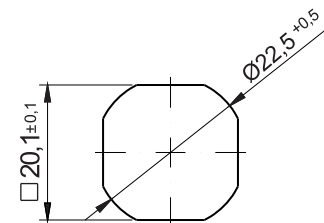
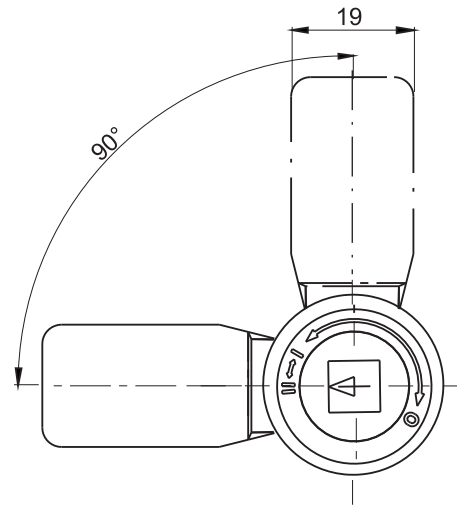
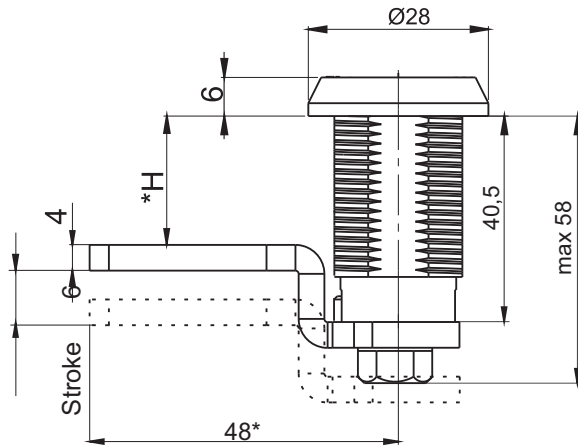

Cut out

Insert				
T9	KW 8	S	N	RAILWAY

TYPE OF LOCK	COMPONENTS	MATERIAL
M22SD40	Housing, insert	Stainless steel
	Cam	

How to order :

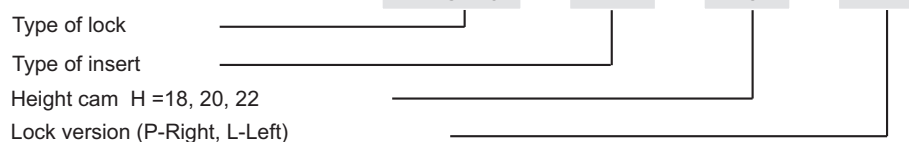

* possibility to make in another dimension
 Lock M22SD40 addition to being locked, has shaped the possibility of additional security padlock.

stainless steel
LH/RH

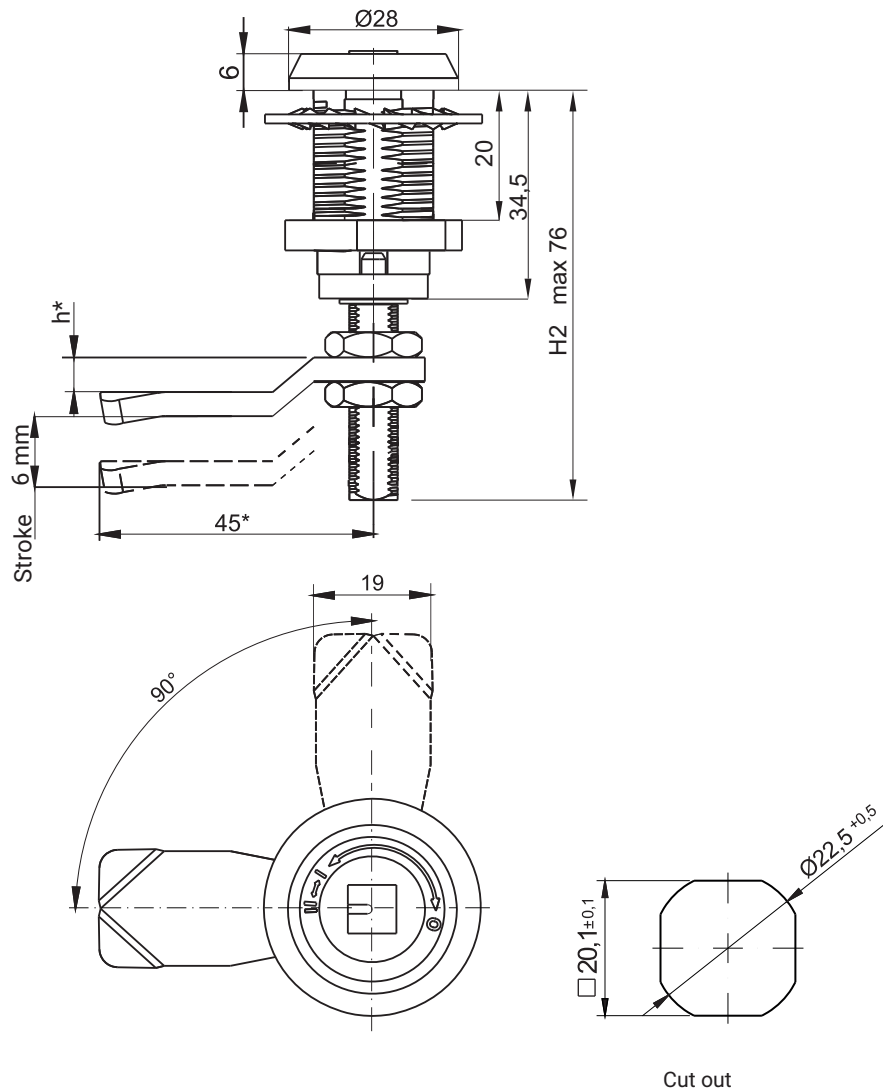

Insert					Finish [C]
					Chrome
T9	KW 8	S	N	RAILWAY	01
TYPE OF LOCK		COMPONENTS		MATERIAL	
M22SC		Housing, insert		ZAMAK5	
		Cam		Steel zinc plated	
M22SC SN		Housing, insert		Stainless steel	
		Cam			

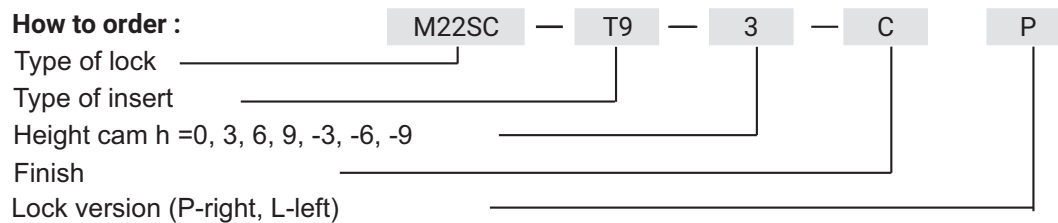

* possibility to make in another dimension
Lock M22SC addition to being locked, has shaped the possibility of additional security padlock.

IP65 LH/RH

Type A

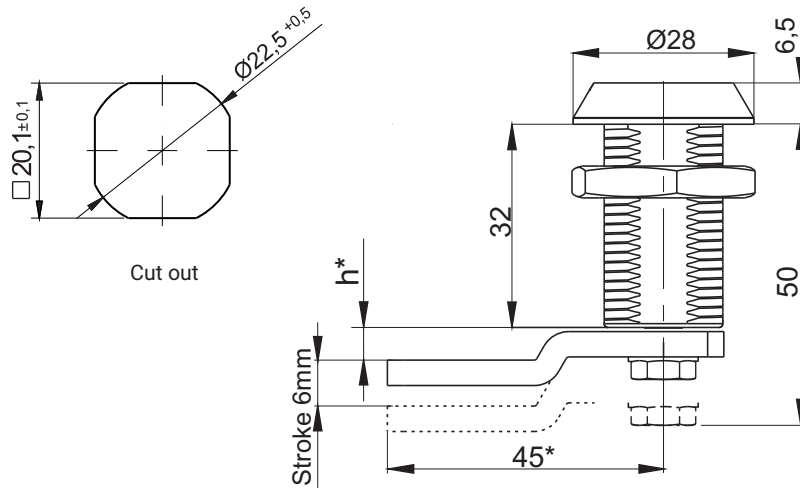

IP65 LH/RH

Type B

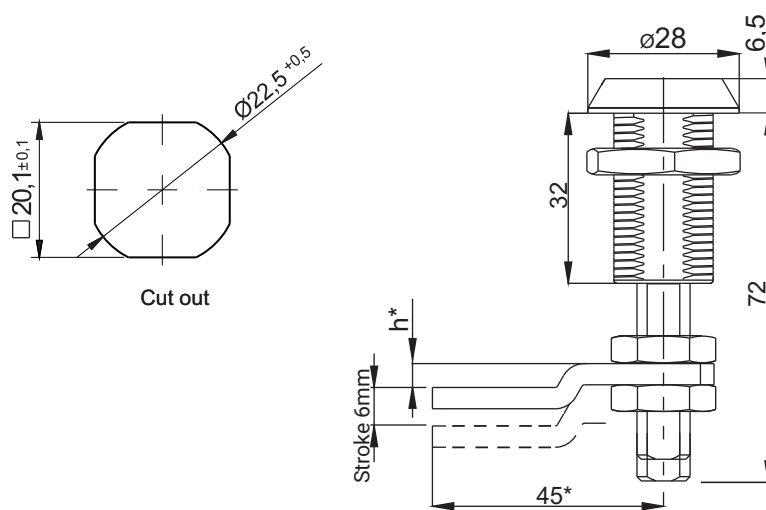

INSERT						FINISH [C]	
						Chrome	RAL 9005
D3	D5	T7	T9	KW 7	KW 8	01	04
TYPE OF LOCK				COMPONENTS		MATERIAL	
M22SA				Housing, insert		ZAMAK5	
				Cam		Steel zinc plated	

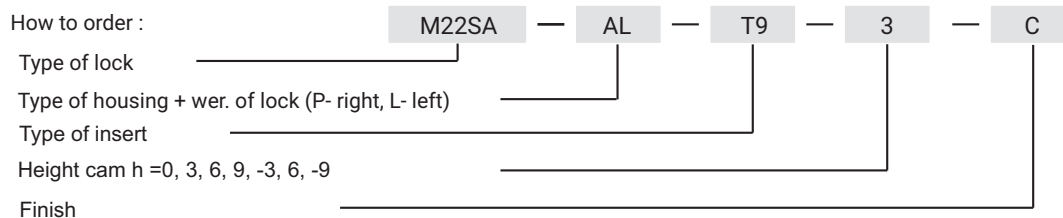

* possibility to make in another dimension

stainless steel IP65 LH/RH

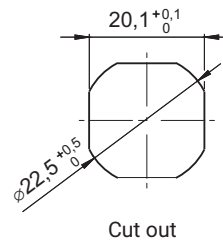
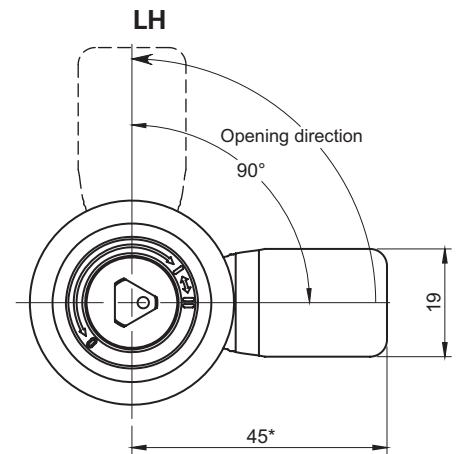
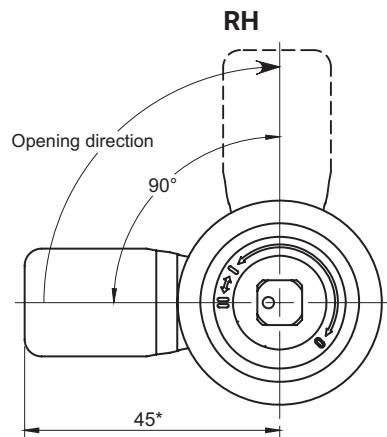
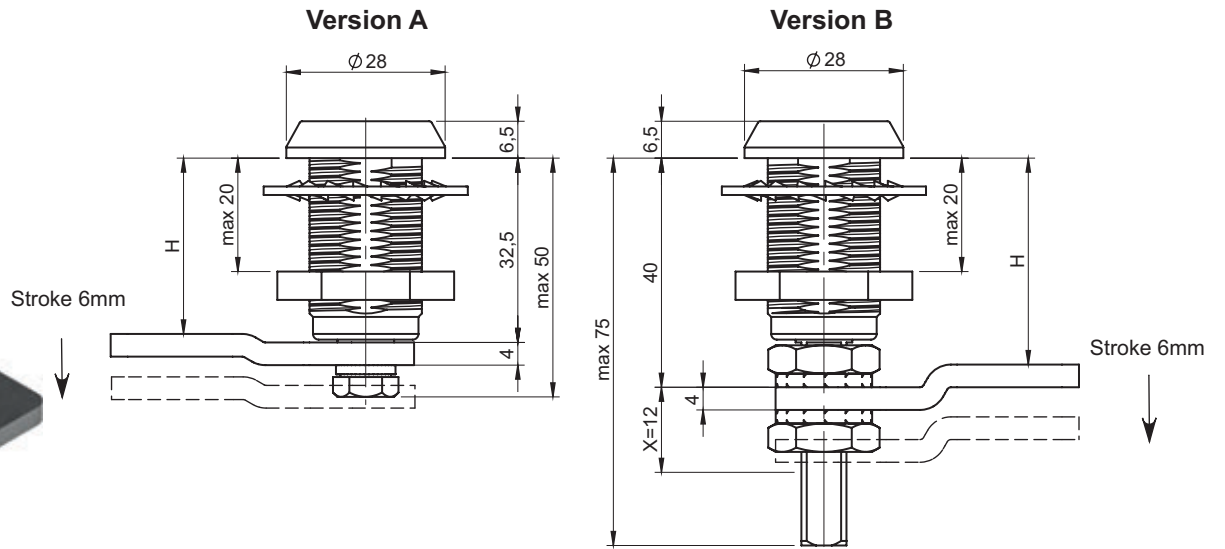

TYPE OF LOCK	COMPONENTS	MATERIAL	INSERT			
M22SE SN	Housing, Insert	Stainless steel				
	Cam		T9	T7	KW8	KW8-2

How to order :

Type of lock
 Type of insert
 Version A, B; (left - LH, right - RH)
 Hight cam
 - for version A H=27,5; 32,5; 37,5
 - for version B H=35; 40; 45

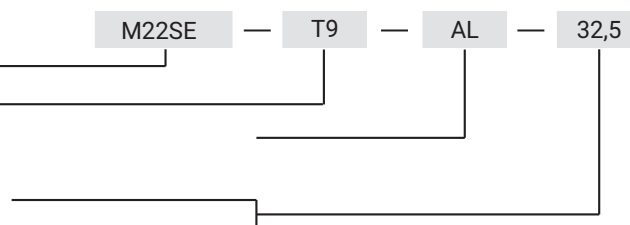

* possibility to make in different dimension

LH/RH

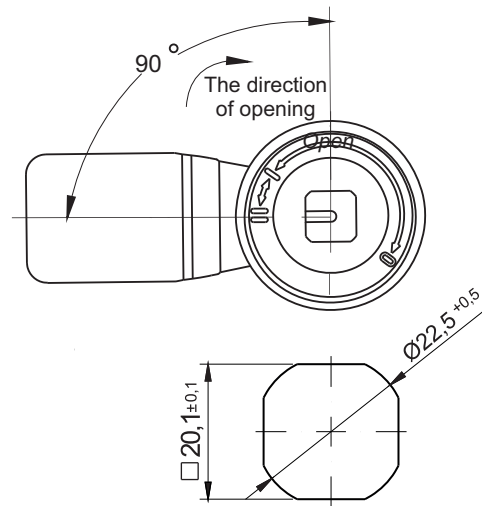
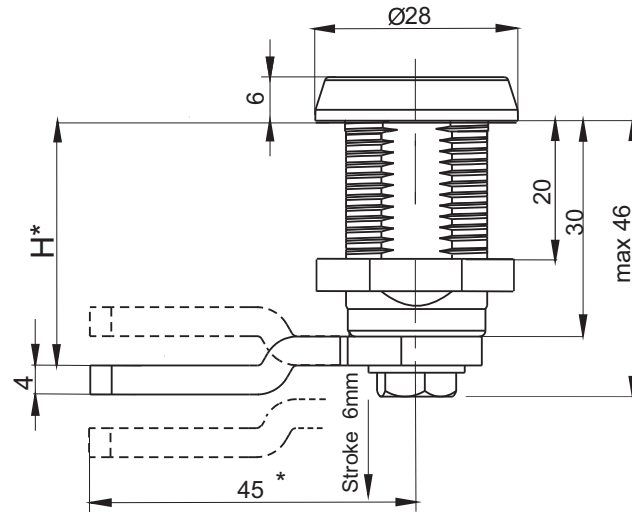

Cut out

INSERT		FINISH [C]	
		Chrom	RAL 9005
T9	KW8	01	04

TYPE OF LOCK	COMPONENTS	MATERIAL
M22SG	Housing, insert	ZAMAK 5
	Cam	Steel zinc plated

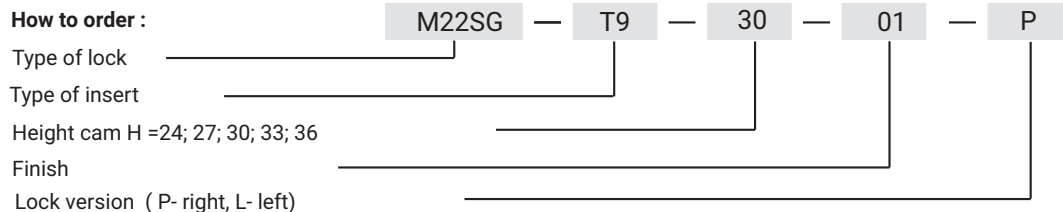

* possibility to make in another dimension

stainless steel

IP65

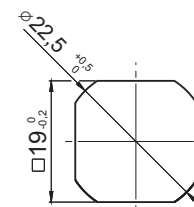
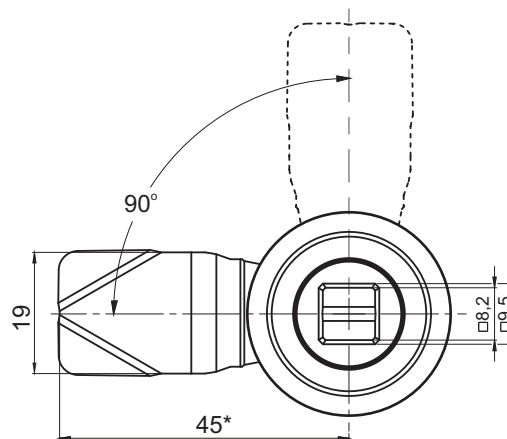
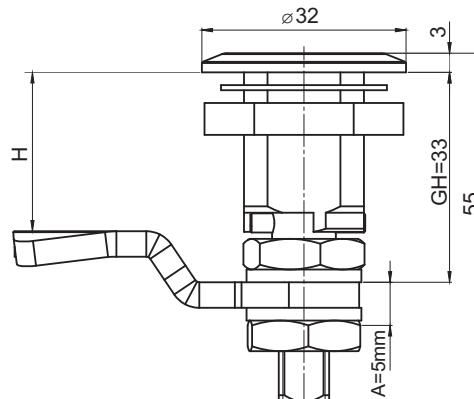

Cut out

A - the height of the latch adjustment H

TYPE OF LOCK	COMPONENTS	MATERIAL
M22JR-SN	Housing, Insert, Cam	Stainless steel

How to order :

Type of lock
Type of insert

The hight of cam H=27, 31, 33, 35, 39

M22JRSN — KW8/9,5 — 27

* possibility to order in a different dimension

stainless steel

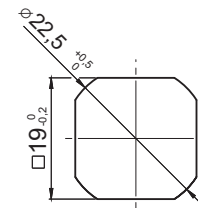
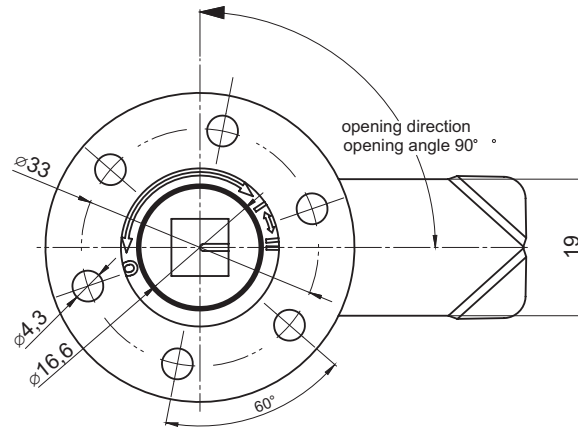
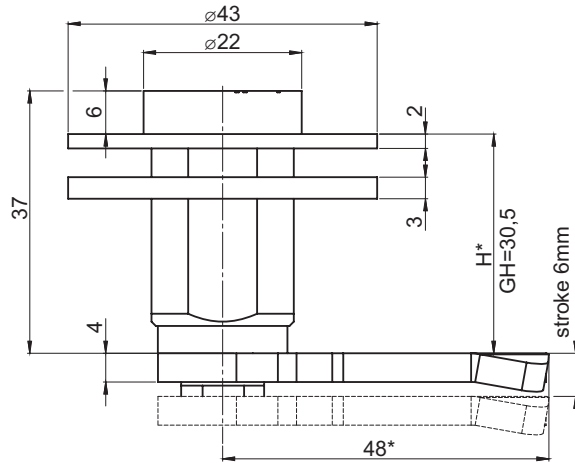

Cut out

INSERTS					FINISH [C]
					Chrome
T9	KW 8	S	N	RAILWAY	01

TYPE OF LOCK	COMPONENTS	MATERIAL
M22SK30	Housing	ZAMAK5
	Insert	Stainless steel
	Cam, Washer, Nut	Zinc plated steel
M22SK30SN	Housing, Insert, cam, washer, Nut	Stainless steel

How to order:

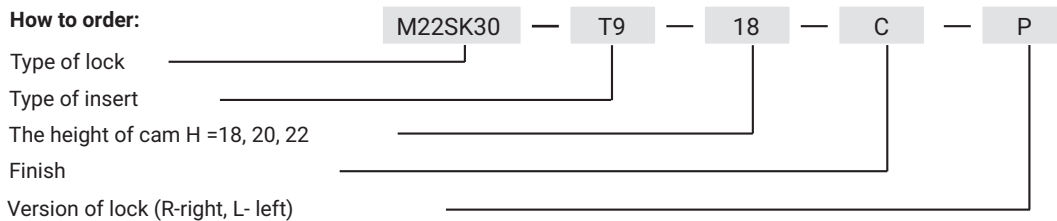

* Possibility to order in a different dimension



Version A

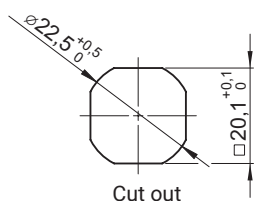
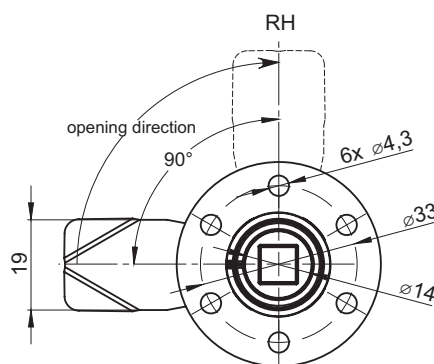
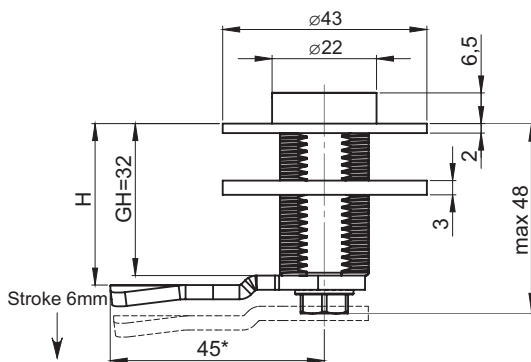

Version B

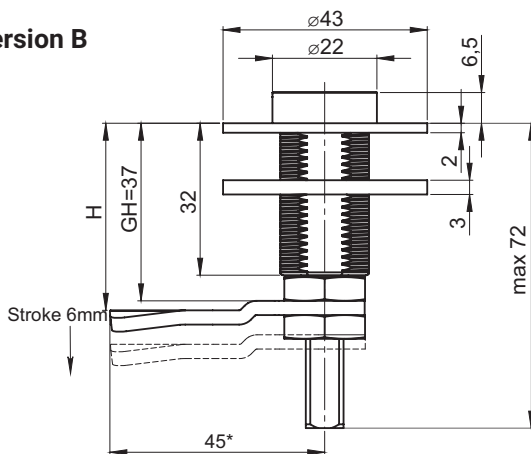

INSERTS					FINISH [C]	
					Chrome	RAL 9005
D3	D5	T9	KW 7	KW8	01	04
TYPE OF LOCK			COMPONENTS		MATERIAL	
M22SK32			Housing, Insert		ZAMAK5	
			Cam, Washer, Nut		Zinc plated steel	

How to order:

M22SK32 — T9 — BL — 32 — C

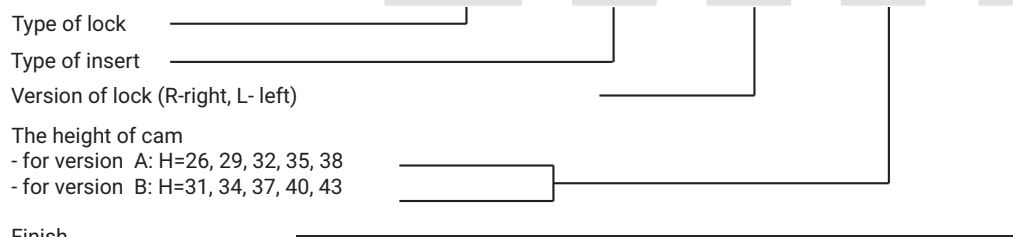

* Possibility to order in a different dimension

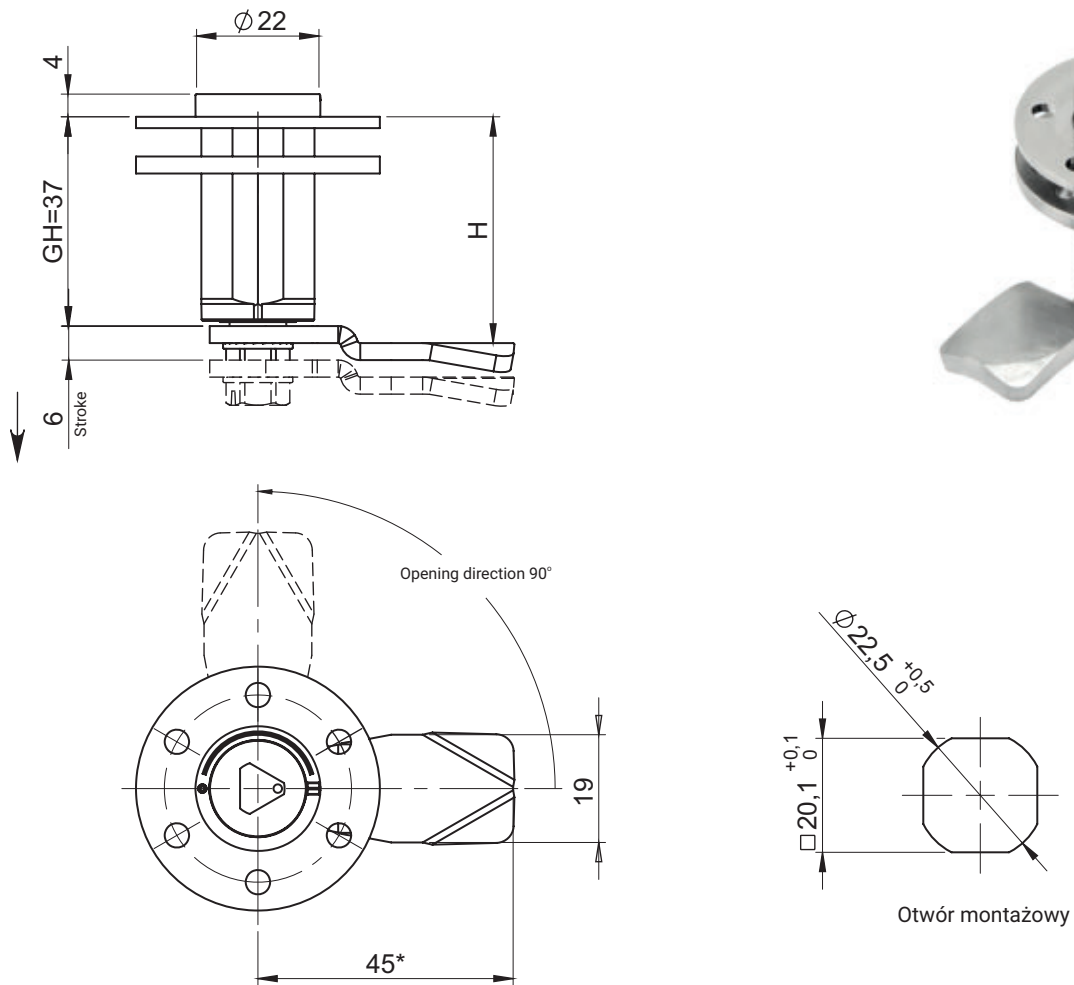

The lock shown fits left-hand doors. The lock for right-hand doors is a mirror image.

TYPE OF LOCK		COMPONENTS		MATERIAL
M22SK37		Housing, Insert		ZAMAK5
		Cam, Washer, Screw, Internal Mechanism		Zinc plated steel
INSERTS		FINISH [C]		
		Chrome	RAL9005	
KW8	T8	01	04	

How to order:

- Type of lock
- Version of lock R-right, L- left
- Housing finish
- Type of insert
- Insert finish
- Height locking

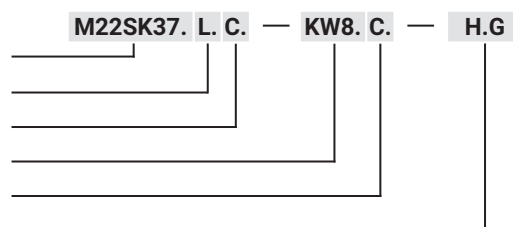

meaning:

- H - the cam unbending dimension
- G - cams range

Lock M22SK37 is compatible with cams from groups: 15, 16, 19, 35, 36 (page 1C-12 - 1C-19)

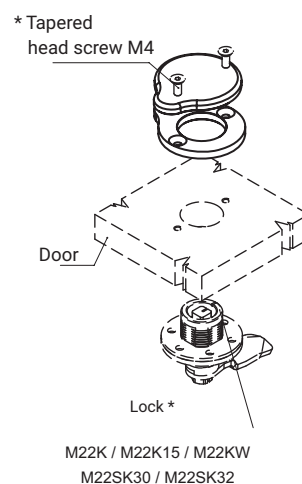
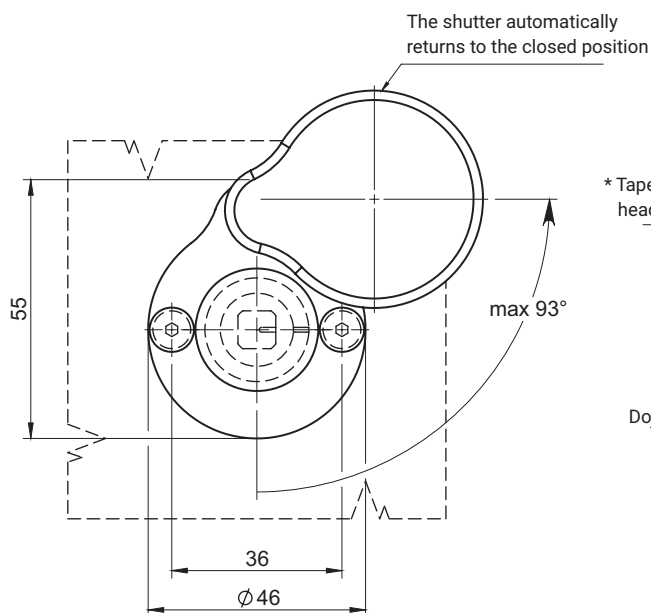
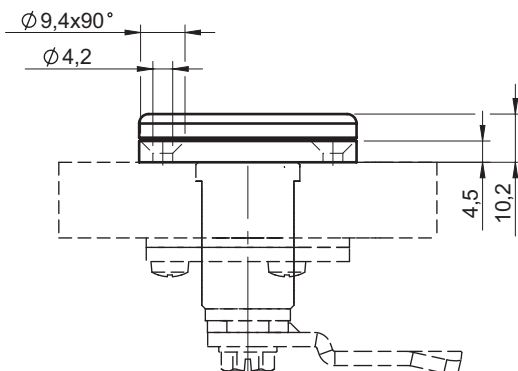

Cover 2.904.020SN compatible with locks: M22K, M22K15, M22KW, M22SK30, M22SK32, M22SK37.
* not included in delivery

NR CATALOGUE NUMBER	DETAIL	MATERIAL
2.904.020SN	Przesłona	Stainless steel, electropolished

Version A

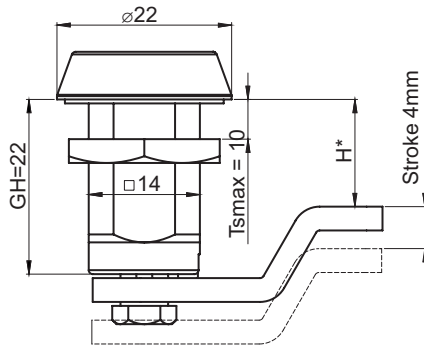

Version B

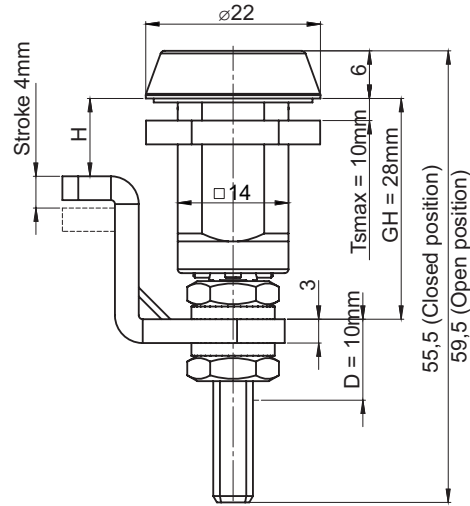

stainless steel IP65 LH/RH

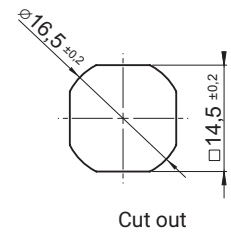
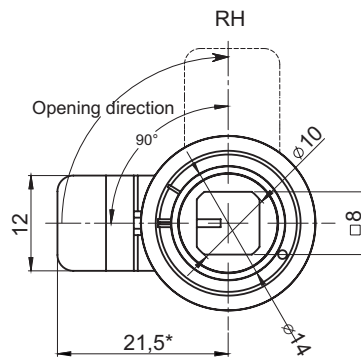
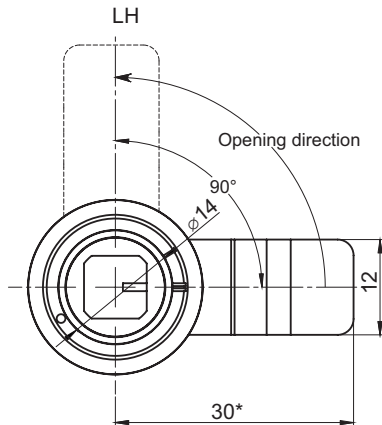

Height adjustment H cam for lock in version B

Cam	H
1 Bended 18mm	10 - 20
	46 - 56
2 Bended 9mm	19 - 29
	37 - 47
3 Straight	28 - 38

The lock has IP65.
 The lock has double pressure.
 The lock is fitted with the key 2.KLKW8.001 (str. 2A-112 - 2A-113).
D - the range of latch adjustment M16SD22 type B.
Ts - the thickness of sheet steel.
 In lockM16SD22 type B bended can be fitted double sided.

TYPE OF LOCK	ELEMENTY SKŁADOWE	MATERIAL
M16SD22	Housing, Insert, Cam	Stainless steel

How to order :

M16SD22 — KW8 — BL — 22

Type of lock _____

Type of insert _____

version of lock + opening direction A, B; L- left, R-right _____

The height of cam _____

- for version A: H=13, 22, 31, 40 _____

- for version B: Cam 1, 2, 3 (chart above) _____

Inserts

T9 KW 8

stainless steel **IP65**

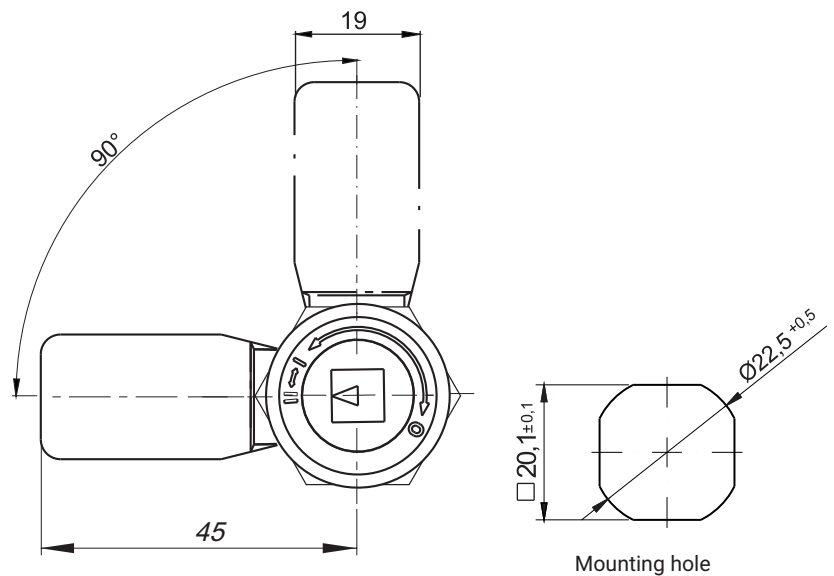
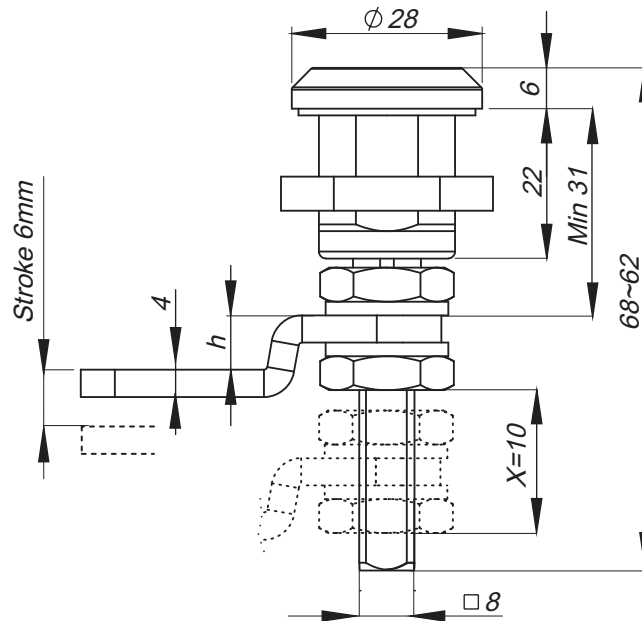

Lock has IP65
 The lock has two sided clamp.
 The x value means the range of adjusting the bar.

Inserts

T9	KW 8

TYPE OF LOCK	COMPONENTS	MATERIAL
M22SD22	Housing, insert	Stainless steel 304
	Cam	Stainless steel 304

How to order:

M22SD22 — T9 — 22 — SN — P

Type of lock _____

Type of insert _____

Height cam h = 22, 25, 28, 31, 34, 37, 40 _____

Finishing _____

Version (L- left, P-right) _____

stainless steel	RoHS	LH/RH
-----------------	------	-------

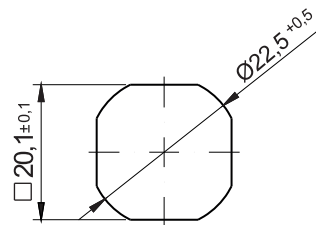
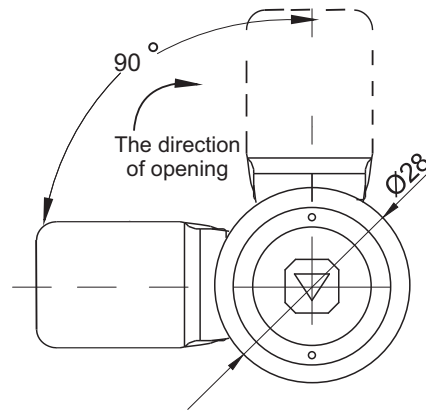
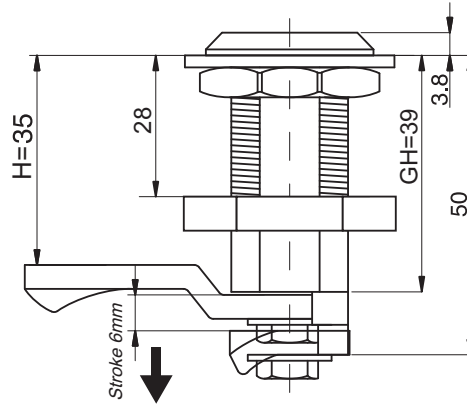

Cut out

Insert		
KW 8		
TYPE OF LOCK	COMPONENTS	MATERIAL
2.530.001	Housing, insert	Stainless steel
	Cam	Stainless steel

* possibility to make in another dimension

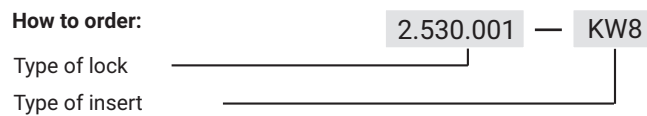

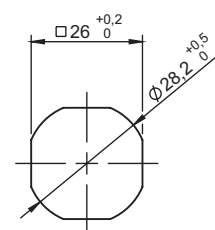
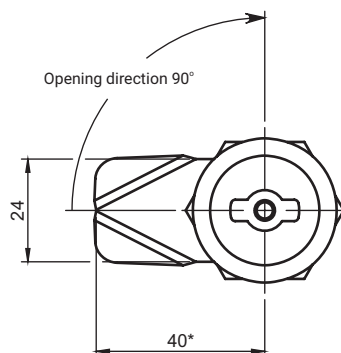
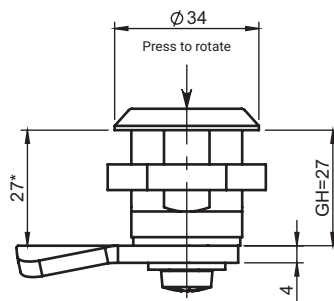

Mounting hole

Lock with protection from undesirable opening without specific key.
 Rotation of locking cam is possible after pushing pin by key.
 Key removal possible only in locking positon of the lock.
 Lock works with key 2.KL-D5.001 (pg. 2A-112 - 2A-113).

TYPE OF LOCK	COMPONENTS	INSERT [X]	MATERIAL
M28-1	Housing, Insert, Cam	 D5	Stainless steel electropolished

How to order:

Type of lock

Type of insert [X]

Material / finih



* possibility to make in another dimension

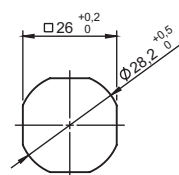
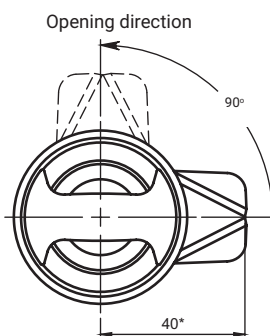
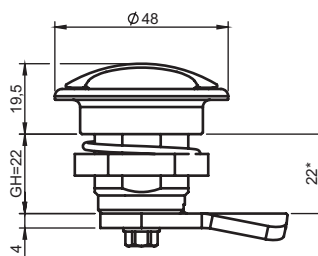

Mounting hole

TYPE OF LOCK	COMPONENTS	MATERIAL
M28-2	Housing, Insert, Cam	Stainless steel electropolished

LH/RH

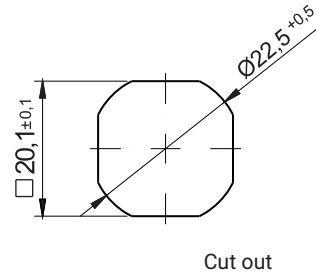
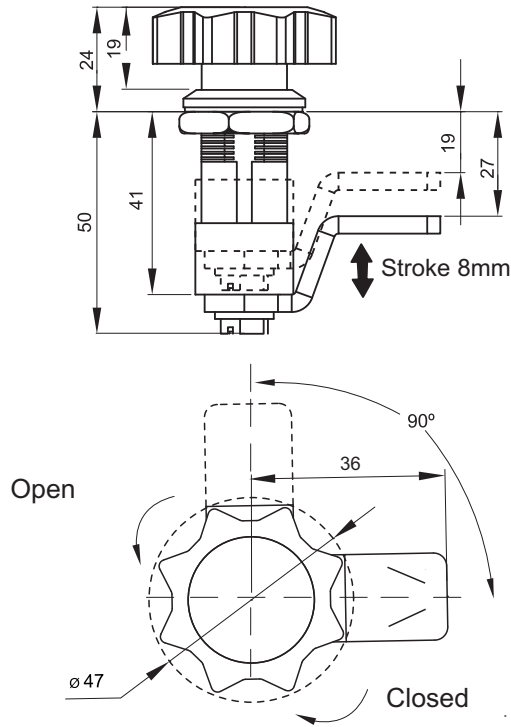

TYPE OF LOCK	COMPONENTS	MATERIAL	FINISH [C]
			Chrome
2.528.001	Housing, insert	ZAMAK 5	01
	Cam	Steel zinc plated	-

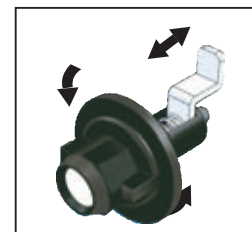
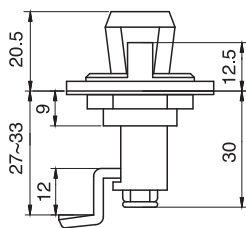
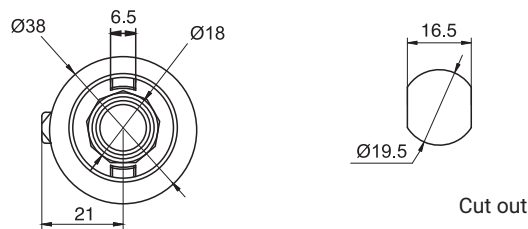

TYPE OF LOCK	COMPONENTS	MATERIAL	FINISH [C]
			RAL 9005
2.528.002	Housing, knob	Polyamide	07
	Cam	Steel zinc plated	-

How to order:

Type of lock
Finish

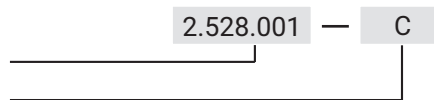

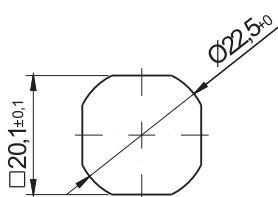
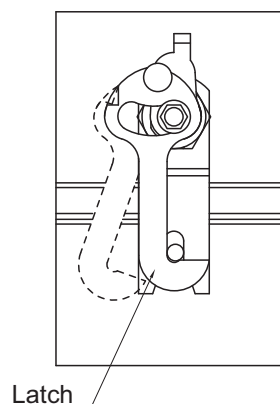
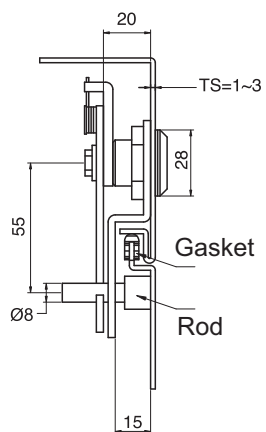

Cut out

TYPE OF LOCK	COMPONENTS	MATERIAL	FINISH [C]
			Chrome
2.525.001	Housing, Insert	ZAMAK5	01
	Latch	Steel zinc plated	-

IP54

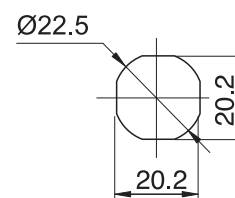
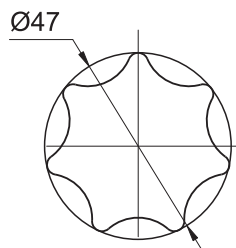
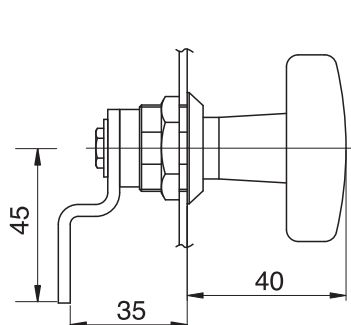

Cut out

Turn angle 90°

TYPE OF LOCK	COMPONENTS	MATERIAL	FINISH [C]
			RAL 9005
2.527.001	Housing	ZAMAK 5	04
	Insert	Polyamide	04
	Cam	Steel zinc plated	-

How to order:

Type of lock
Finish

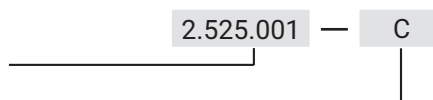

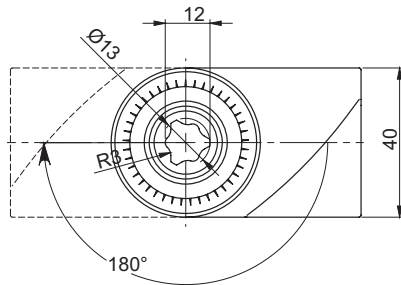
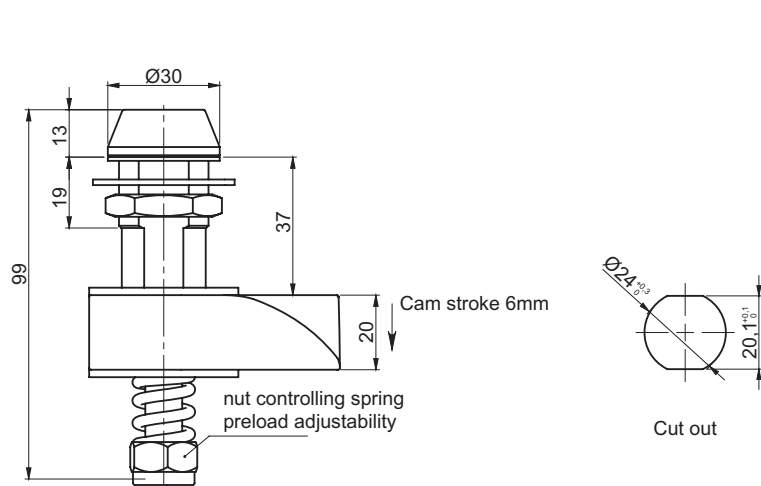

INSERTS	
T10	BT

TYPE OF LOCK	COMPONENTS	MATERIAL
M24C	Housing, Insert	Stainless steel
	Cam	Polyamide
	Nut	Brass

How to order:

Type of lock
Type of insert
Finish

M24C — T10 — SN

Lock is equipped with spring preload adjustability

RoHS

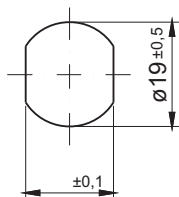

Cut Out

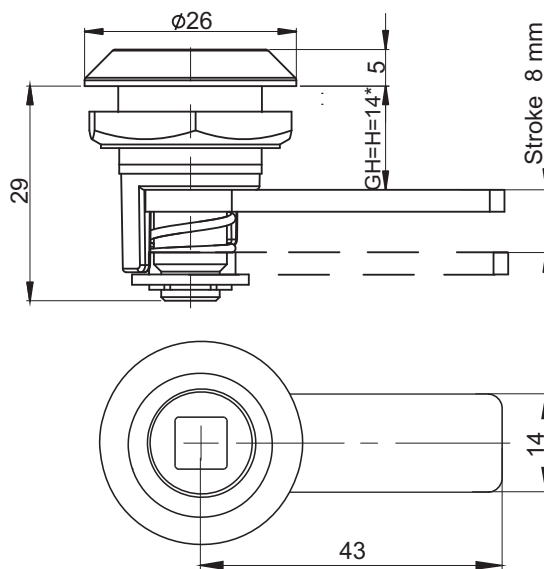

INSERT			FINISH [C]			
			Chrome	Nickel	RAL 9005	RAL 7035
T9	KW 8	S	01	02	04	05
TYPE OF LOCK		COMPONENTS		MATERIAL		
M19DC		Housing		ZAMAK5		
		Cam, insert		Steel zinc plated		

RoHS

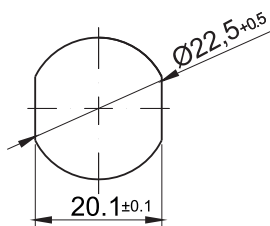

Cut Out

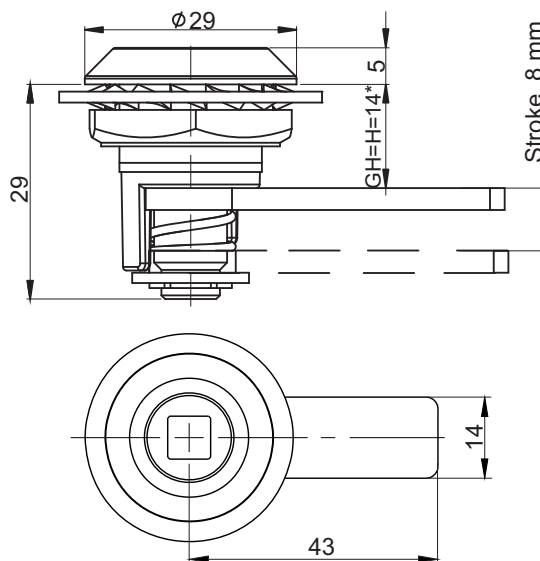

INSERT			FINISH [C]			
			Chrome	Nickel	RAL 9005	RAL 7035
T9	KW 8	S	01	02	04	05
TYPE OF LOCK		COMPONENTS		MATERIAL		
M22DC		Housing		ZAMAK5		
		Cam, insert		Steel zinc plated		

How to order :

Type of lock

Type of insert

Height cam H = 14, 17, 20

Finish

* possibility to make in another dimension

M22DC — T9 — 14 — C

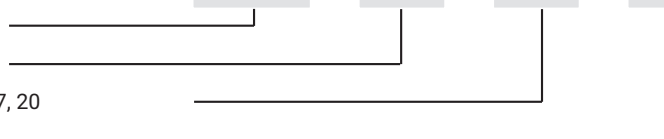

LH

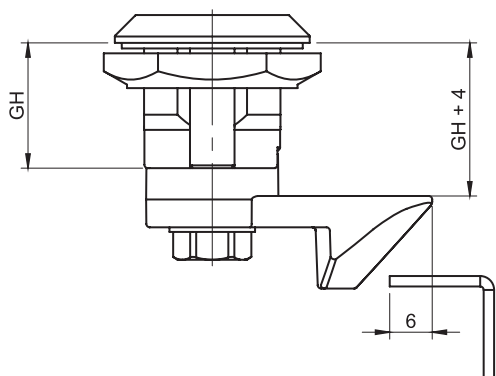

Lock with cam on left version

Automatic return of the lock to the closed position

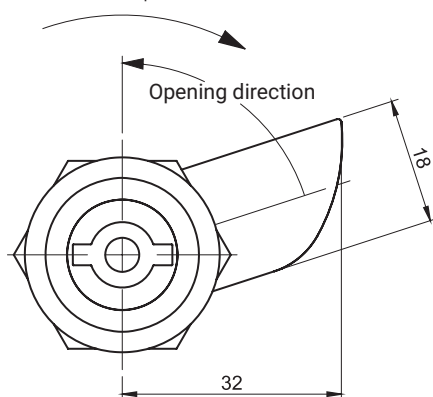

Lock in the left version, the right version is a mirror reflection

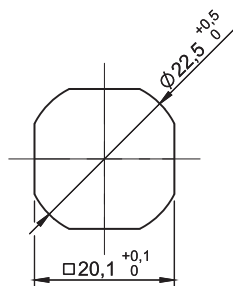

Cut out

RH



Locks with cam on right version

CATALOGUE NUMBER		VERSION	MATERIAL						
JZ-3522L		Left	ZAMAK						
JZ-3522P		Right							
COMPATIBLE LOCKS M22			INSERTS	FINISH [C]					
TYPE OF LOCK	GH	MATERIAL							
M22-3	18	ZAMAK				Chrome	Nickel	RAL9005	RAL7035
M22-30	30		KW8	D5	T9	01	02	04	05
M22-60	60								

How to order :

Type of lock

Type of insert

Finish[C]

Cam catalogue number

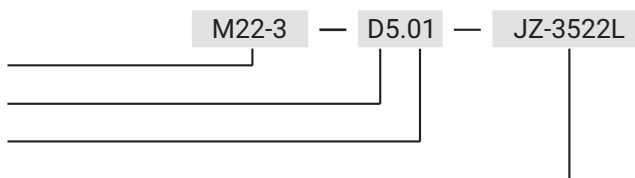

NEW

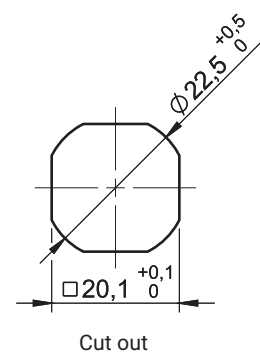
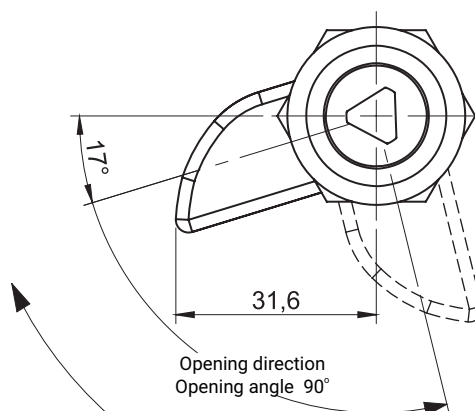
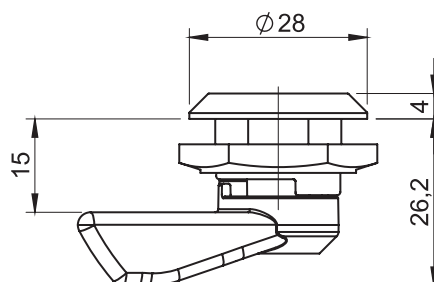

The lock automatically returns to the closed position

TYPE OF LOCK	INSERT	COMPONENTS	MATERIAL	FINISH [C]
				Chrome
M22-6	 T8	Housing, Insert, Latching cam	ZAMAK	01

How to order:
Type of lock
Type of insert
Finish [C]



Lock with padlockable mechanism

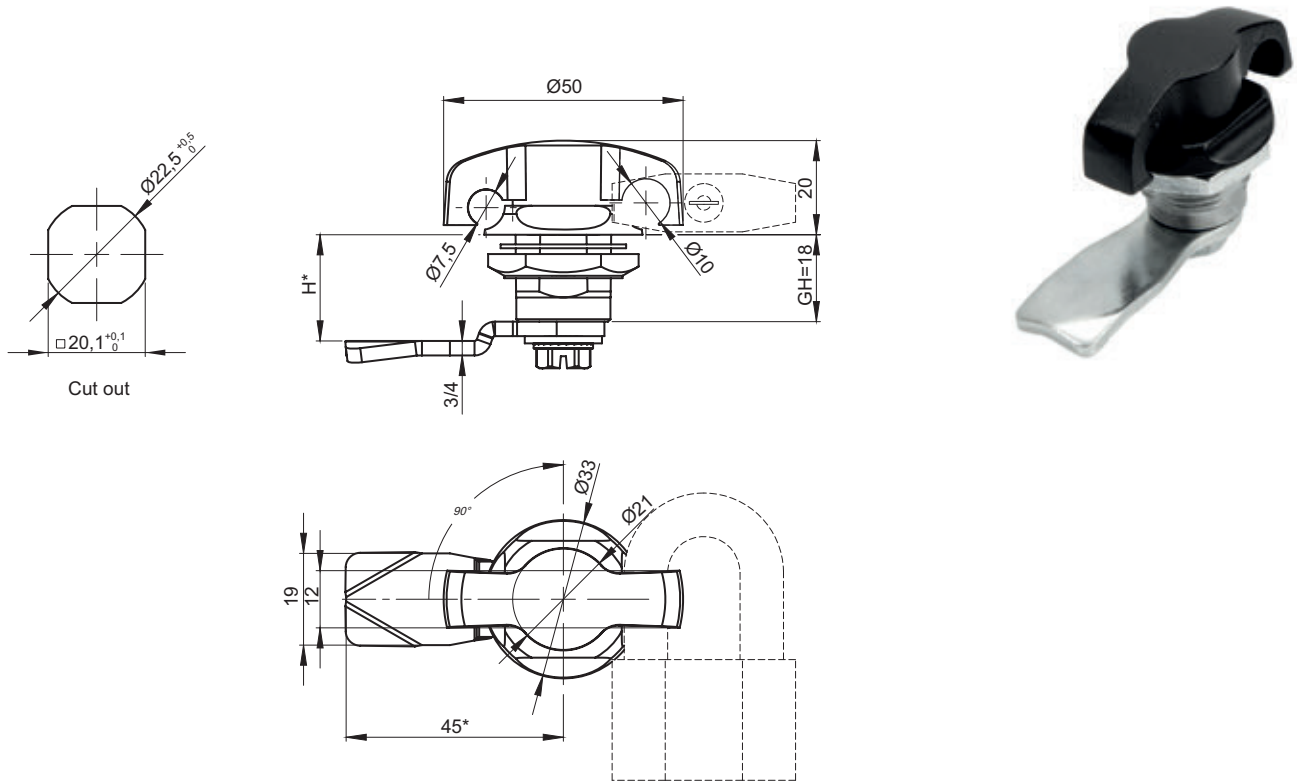

CATALOGUE NUMBER	COMPONENTS	MATERIAL	FINISH [C]
M22PM-K	Housing, Insert	ZAMAK	RAL 9005
	Cam	Steel	04
M22PM-K.SN	Housing, Insert, Cam	Stainless steel	-



Notes:
 Lock M22PM-K is compatible with cams without limiter from groups:
 15, 16, 18, 35, 36, JK-10018, J-6000.01, J-6000.02

H.G - the cam unbending dimension (H-locking height, G-group)

State the cam thickness at order.
 Padlock is not included.
 * different dimensions available

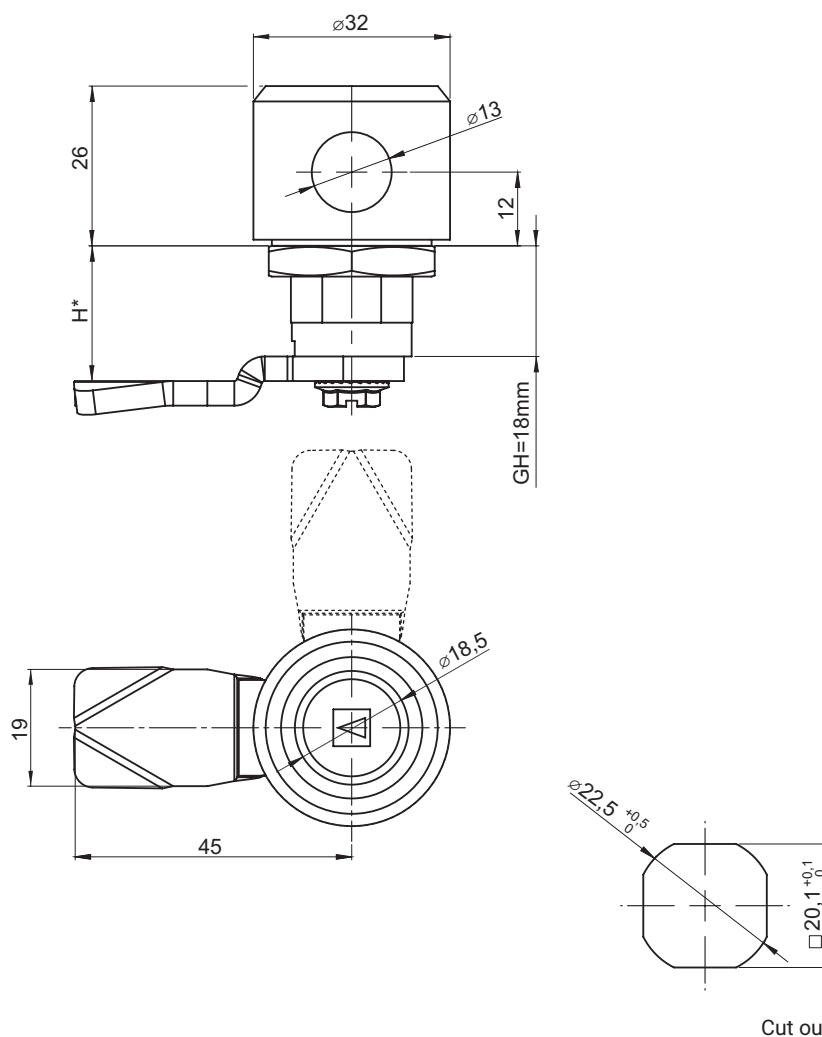

INSERTS			
D5	KW 6	T8	
TYPE OF LOCK	COMPONENTS	MATERIAL	FINISH [C]
			RAL 9005
M22BK	Housing, Insert	ZAMAK	04
	Cam	Zinc plated steel	-



The lock is fitted with cams without the limiter from the group: 15, 19, 35 (pg. 1C-12, 1C-14, 1C-19), H.G - the cam unbending dimension (H-locking height, G-group)

Lock with padlockable mechanism

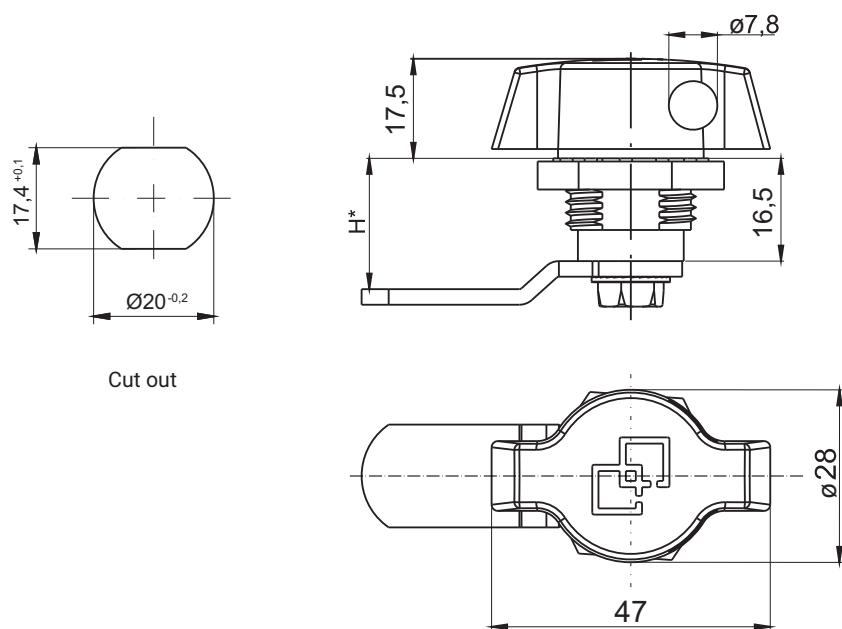

TYPE OF LOCK	COMPONENTS	MATERIAL	FINISH [C]
			Chrome
2.506.001	Housing, Knob	ZAMAK5	01
	Cam	Steel zinc plated	-

How to order:

Type of lock
Type of cam
Finish

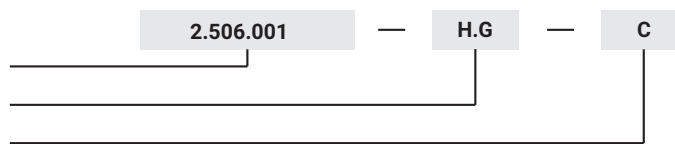

H.G - the cam unbending dimension (H-locking height, G-group) to be chosen from pages 1C-9 to 1C-22
The lock is fitted with cams from the group: 15, 16, 35, 36

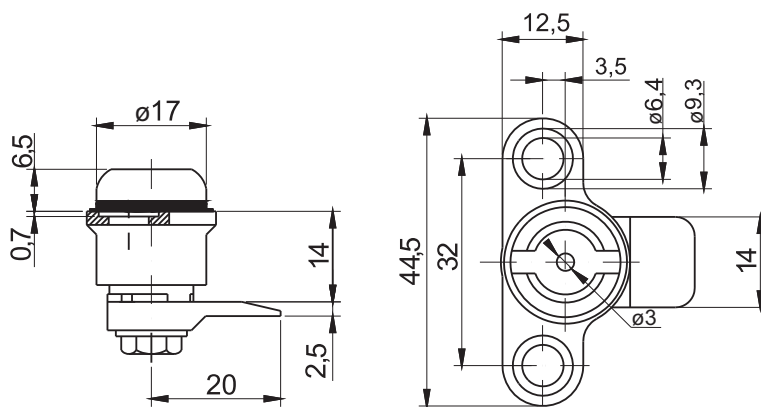

TYPE OF LOCK	COMPONENTS	MATERIAL	FINISH [C]
			Nickel
2.M19.001	Housing, Cam	ZAMAK5	02

How to order:

Type of lock
Finish

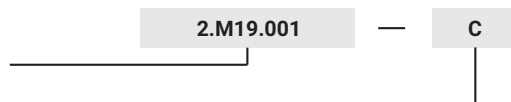



Left version
2.630.001

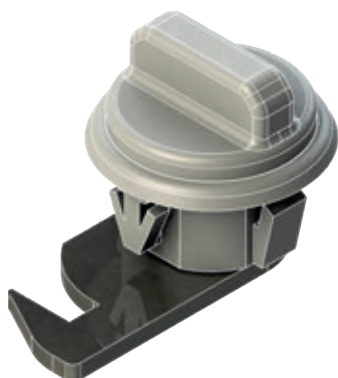

Right version
2.630.002

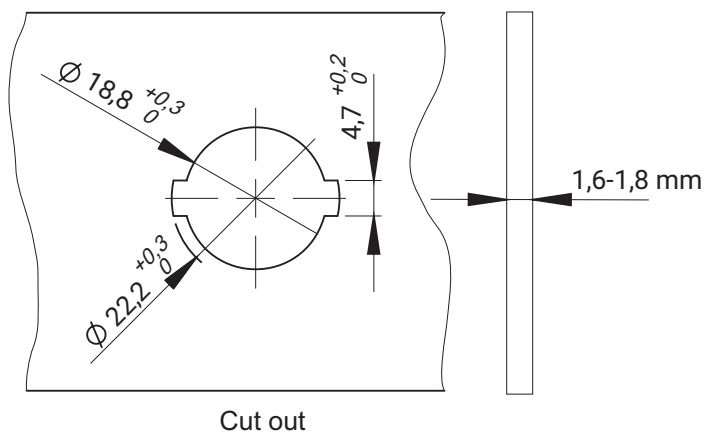
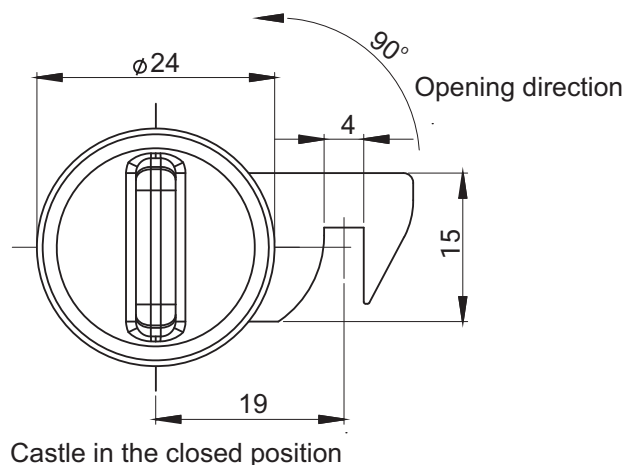
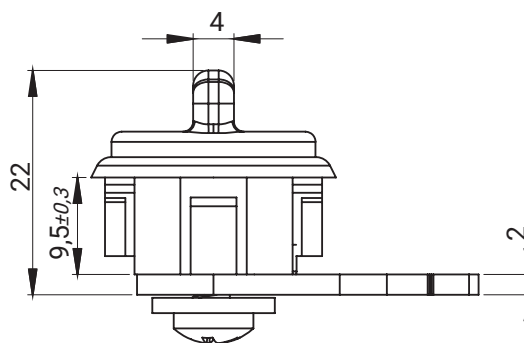

Note: The snap lock adapted to components made of plastic artificial.

Lock automatically after opening back to the closed position.

TYPE OF LOCK	COMPONENTS	MATERIAL	FINISH [C]	
			RAL 9005	RAL 7035
2.630.001	Housing, insert	Polyamide	07	08
2.630.002	Cam	Steel zinc plated	-	-

How to order:

Type of lock

Finish

2.630.001

— C

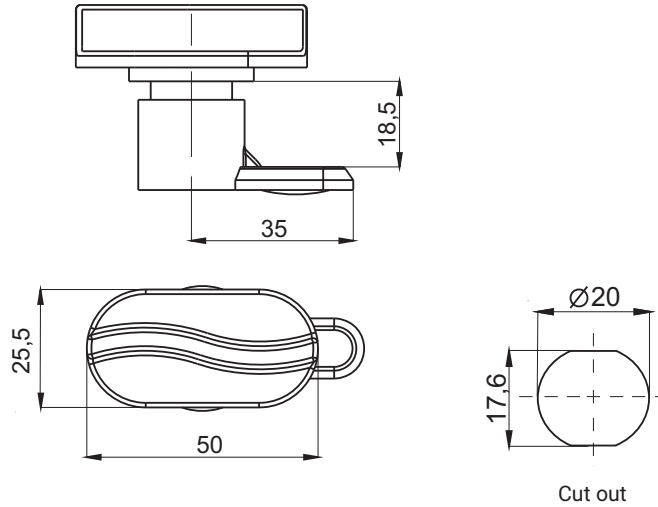

TYPE OF LOCK	COMPONENTS	MATERIAL	FINISH [C]	
			RAL 9005	07
2.603.001	Housing, insert	Polyamide		

How to order :

Type of lock
Finish

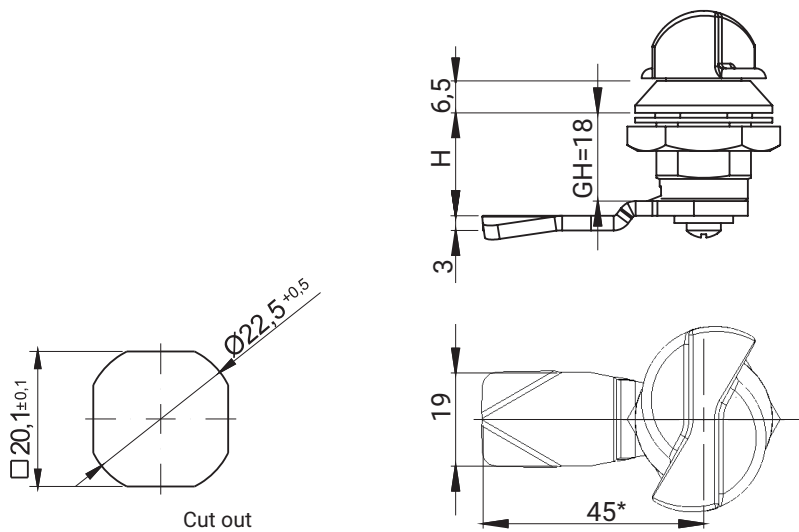
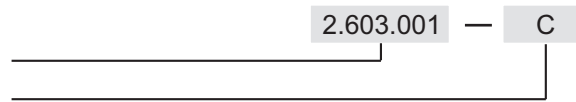

TYPE OF LOCK	COMPONENTS	MATERIAL	FINISH [C]	
			RAL 9005	RAL 7035
M22D-M	Housing, insert	Polyamide	07	08
	Cam	Steel zinc plated	-	-

How to order :

Type of lock
Type of cam (page 1C-9 - 1C-24)
Colour (RAL 9005, RAL 7035)

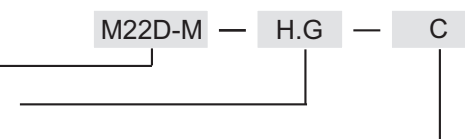

* possibility to order in another dimension
H.G - the cam unbending dimension (H-locking height, G-group)

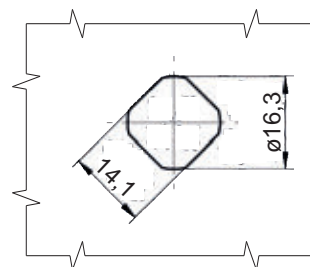
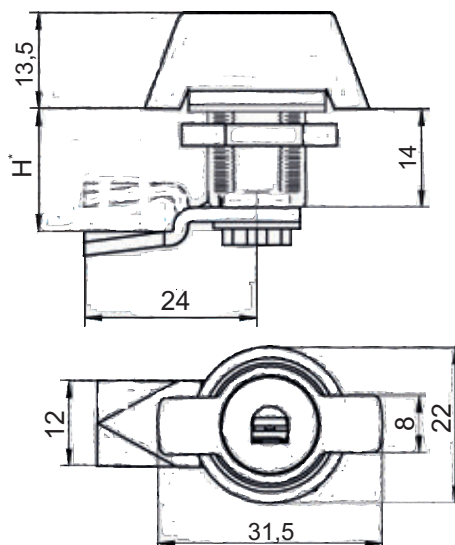

Cut out

Note: The lock is mounted with the key code 2233X

CATALOGUE NUMBER	COMPONENTS	MATERIAL	FINISH [C]	
			Chrome	RAL 9005
2.616.001-H	Housing	ZAMAK5	-	04
	Cam	Steel zinc plated	-	04
2.616.101-H	Housing	ZAMAK5	01	-
	Cam	Steel zinc plated	01	-

* possibility to order in another dimension

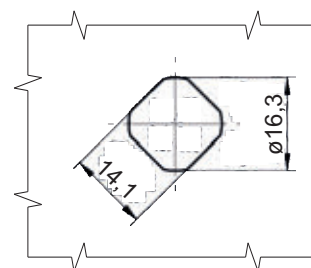
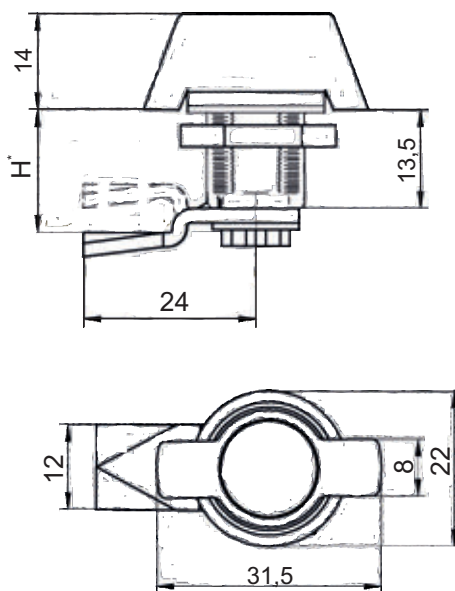

Cut out

CATALOGUE NUMBER	COMPONENTS	MATERIAL	FINISH [C]	
			Chrome	RAL 9005
2.616.002-H	Housing	ZAMAK5	-	04
	Cam	Steel zinc plated	-	04
2.616.102-H	Housing	ZAMAK5	01	-
	Cam	Steel zinc plated	01	-

* possibility to order in another dimension

How to order :

Type of lock

The height of cam H

Finish

2.616.002 — H — C

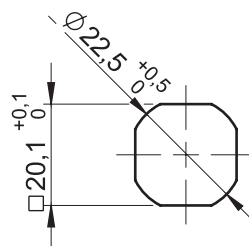
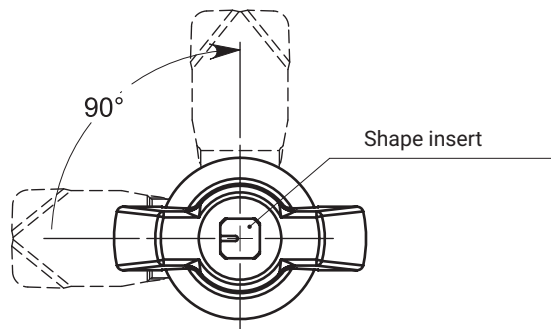
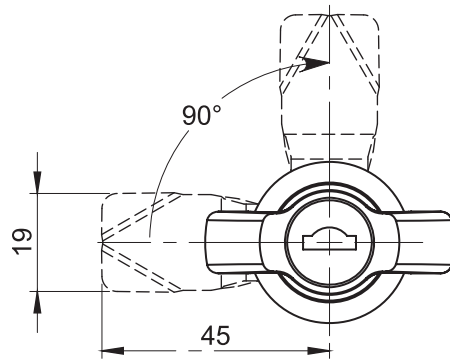
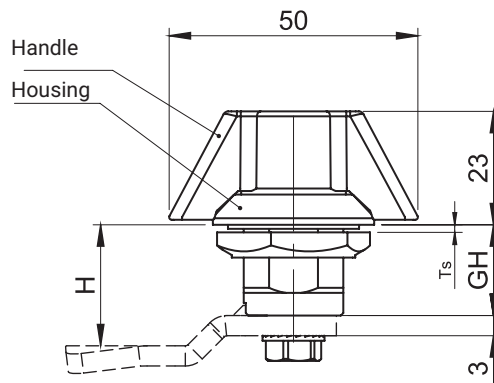

Mounting hole

LOCK WITH METAL BUTTERFLY HANDLE					
GH VALUE	CATALOGUE NUMBER			MATERIAL AND FINISH	
	Cylinder 1333	Cylinder - RK	Without cylinder	Handle	Housing
				ZAMAK	
GH=18 Tsmax-8	2.PM18.002	2.PM18.004	2.PM18.006	RAL9005	
	2.PM18.001	2.PM18.003	2.PM18.005	Chrom	
GH=30 Tsmax-18	2.PM30.002	2.PM30.004	2.PM30.006	RAL9005	
	2.PM30.001	2.PM30.003	2.PM30.005	Chrom	
GH=40 Tsmax-28	2.PM40.002	2.PM40.004	2.PM40.006	RAL9005	
	2.PM40.001	2.PM40.003	2.PM40.005	Chrom	
GH=60 Tsmax-48	2.PM60.002	2.PM60.004	2.PM60.006	RAL9005	
	2.PM60.001	2.PM60.003	2.PM60.005	Chrom	

LOCK WITH POLYAMIDE BUTTERFLY HANDLE					
GH VALUE	CATALOGUE NUMBER			FINISH [C]	
	Cylinder 1333	Cylinder - RK	Without cylinder	Handle	Housing
				Poliamid*	ZAMAK
GH=18 Tsmax-8	2.PMPA18.002	2.PMPA18.004	2.PMPA18.006	RAL9005	RAL9005
	2.PMPA18.001	2.PMPA18.003	2.PMPA18.005		Chrome
GH=30 Tsmax-18	2.PMPA30.002	2.PMPA30.004	2.PMPA30.006		RAL9005
	2.PMPA30.001	2.PMPA30.003	2.PMPA30.005		Chrome
GH=40 Tsmax-28	2.PMPA40.002	2.PMPA40.004	2.PMPA40.006		RAL9005
	2.PMPA40.001	2.PMPA40.003	2.PMPA40.005		Chrome
GH=60 Tsmax-48	2.PMPA60.002	2.PMPA60.004	2.PMPA60.006		RAL9005
	2.PMPA60.001	2.PMPA60.003	2.PMPA60.005		Chrome

METAL LOCK WITH BUTTERFLY HANDLE WITH SHAPED INSERT					
GH VALUE	CATALOGUE NUMBER		MATERIAL AND FINISH		
	Shape insert KW8	Shape insert T8	Handle	Housing	Insert
			ZAMAK		Steel
GH=18 Tsmax-8	2.PM18-KW8	2.PM18-T8	RAL9005		

How to order:

Catalogue number
Type of cam

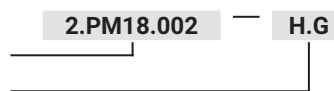

where:

H.G:

H - height locking

G - cams range

Ts - Thickness door

Lock is compatible with all cams from range: 11, 12, 13, 14, 18, 31, 32, 34, 38, JK-1610.01

Each lock with a cylinder is supplied with two keys.

* The 2.PMPA lock handle is a two-component, injection-moulded plastic on an internal element made of metal (ZAMAK).

Lock with a butterfly handle and shaped insert. 2.PM18-KW8(T8) allows emergency opening by means of a handle.

The KW8 or T8 key is used to open the standard butterfly lock, which can be operated as a standard.

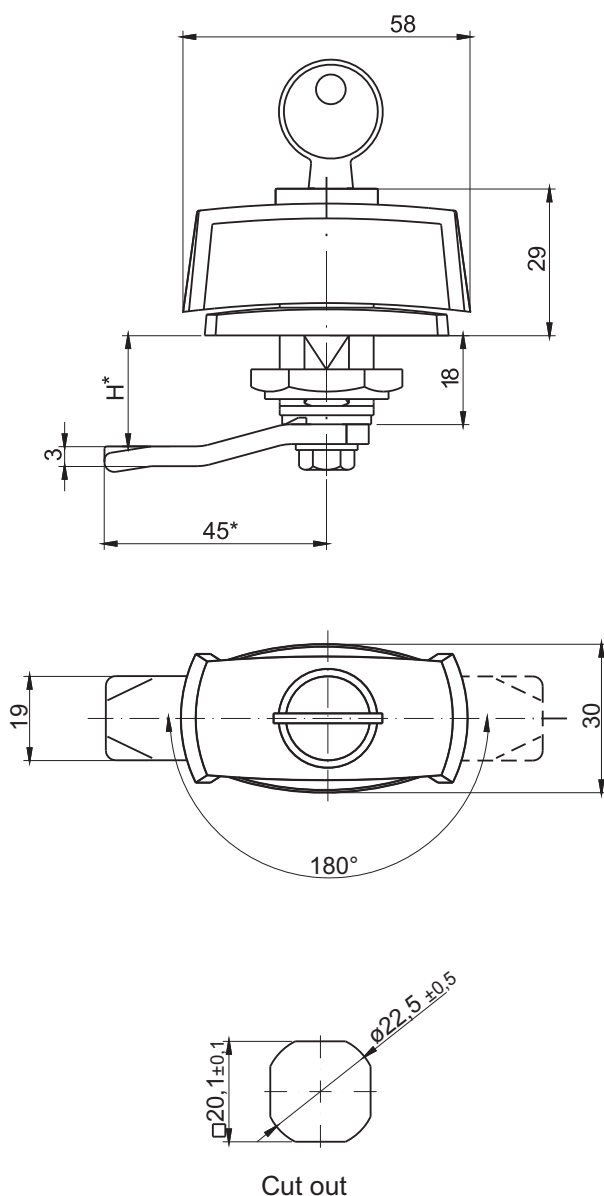

TYPE OF LOCK	COMPONENTS	MATERIAL	FINISH [C]	
			RAL 9005	RAL 7035
RW300	Housing, knob	Polyamide	07	08
	Cam	Steel zinc plated	-	-

How to order:



* possibility to order in another dimension
 H.G - the cam unbending dimension (H-locking height, G-group)
 The lock is fitted with cams from the group: 11, 12, 13, 14, 18, 31, 32, 33, 34, 38, JZ-002, JK-1610.01 (page 1C-7 - 1C-20)

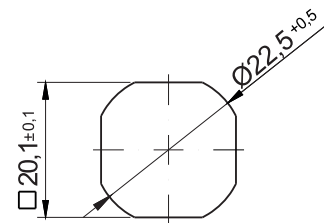
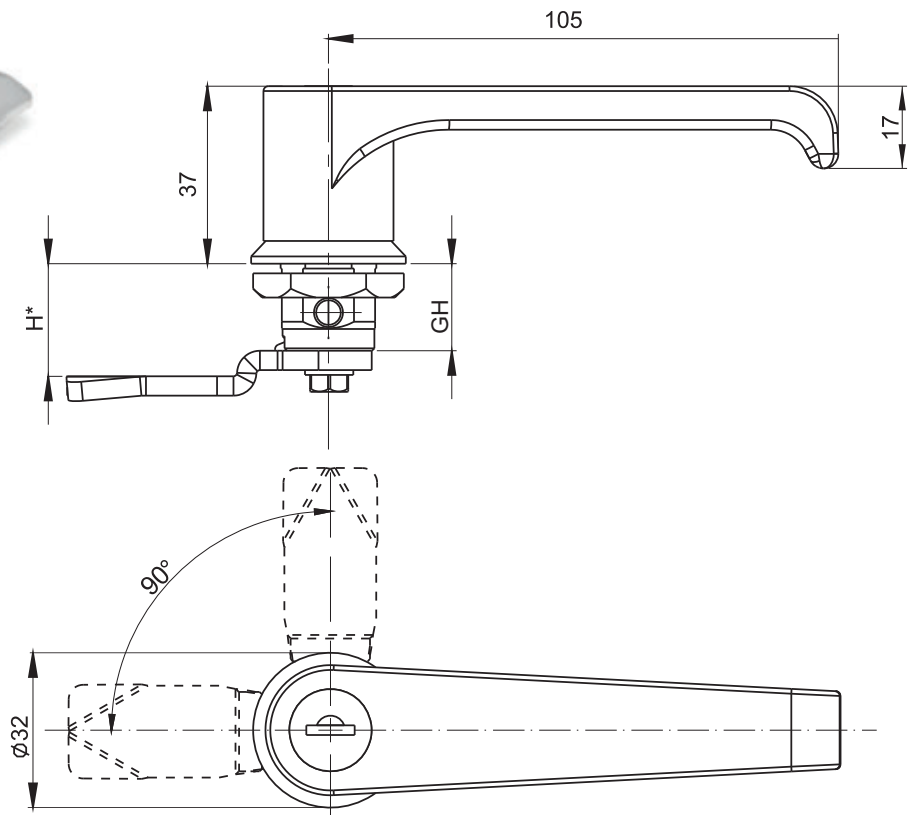

Cut out

NAME	CATALOGUE NUMBER			FINISH [C]
	Cylinder 1333	Cylinder - RK	Without cylinder	
L 18 (GH=18)	2.L18.002	2.L18.004	2.L18.006	RAL 9005
	2.L18.001	2.L18.003	2.L18.005	Chrome
L 30 (GH=30)	2.L30.002	2.L30.004	2.L30.006	RAL 9005
	2.L30.001	2.L30.003	2.L30.005	Chrome
L 40 (GH=40)	2.L40.002	2.L40.004	2.L40.006	RAL 9005
	2.L40.001	2.L40.003	2.L40.005	Chrome
L 60 (GH=60)	2.L60.002	2.L60.004	2.L60.006	RAL 9005
	2.L60.001	2.L60.003	2.L60.005	Chrome

How to order :

Catalogue number

Height cam H (1C-9 - 1C-22)

2.L30.003 — H.G

* possibility to order in another dimension

** possibility to use stainless steel 1.4404

The lock is fitted with cams from the group: 11, 12, 13, 14, 18, 31, 32, 33, 34, 38, JZ-002, JK-1610.01 (page 1C-9 - 1C-22)

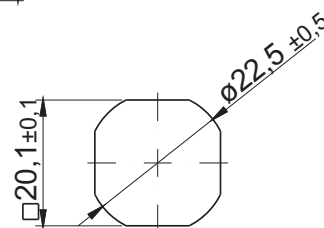
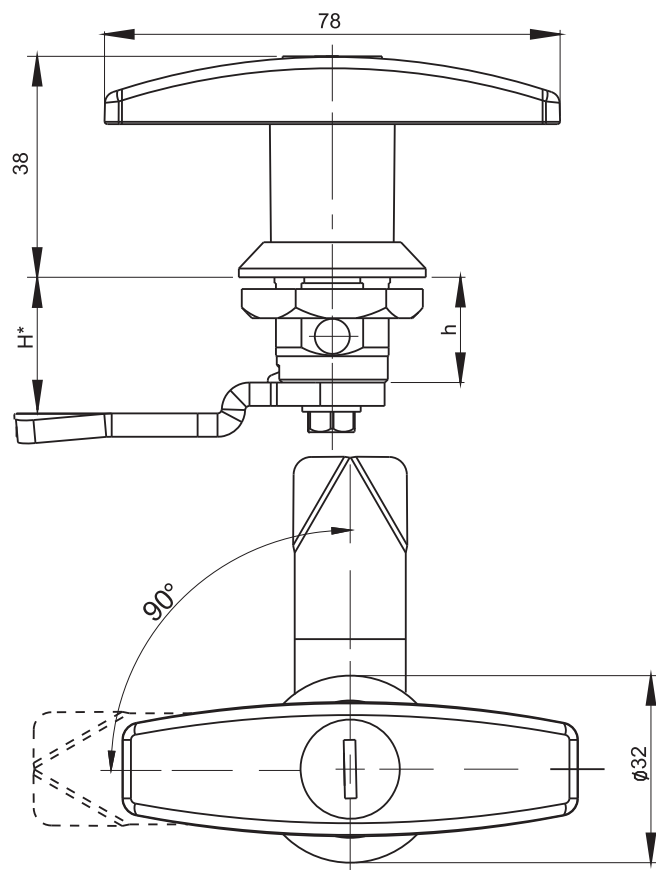

Cut out

NAME	COMPONENTS
Housing, handle	ZAMAK5**
Cam	Steel zinc plated**

NAME	CATALOGUE NUMBER			FINISH [C]
	Cylinder 1333	Cylinder - RK	Without cylinder	
T 18 (GH=18)	2.T18.002	2.T18.004	2.T18.006	RAL 9005
	2.T18.001	2.T18.003	2.T18.005	Chrome
T 30 (GH=30)	2.T30.002	2.T30.004	2.T30.006	RAL 9005
	2.T30.001	2.T30.003	2.T30.005	Chrome
T 40 (GH=40)	2.T40.002	2.T40.004	2.T40.006	RAL 9005
	2.T40.001	2.T40.003	2.T40.005	Chrome
T 60 (GH=60)	2.T60.002	2.T60.004	2.T60.006	RAL 9005
	2.T60.001	2.T60.003	2.T60.005	Chrome

How to order :

Catalogue number

Height cam H (1C-9 - 1C-22)

2.T30.003 — H.G

* possibility to order in another dimension

** possibility to use stainless steel 1.4404

The lock is fitted with cams from the group: 11, 12, 13, 14, 18, 31, 32, 33, 34, 38, JZ-002, JK-1610.01 (page 1C-9 - 1C-22)

NEW

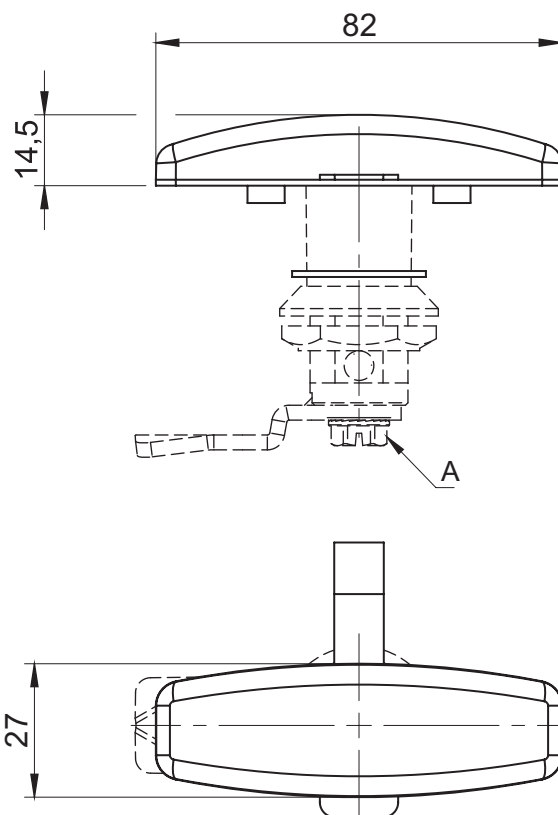

In order to mount the dust cover on the T-handle lock, remove the knob from the lock body by unscrewing the screw (A), then pass the cover through the lock pivot. In order to disassemble repeat in reverse order.

CATALOGUE NO.	COMPATIBLE LOCKS	MATERIAL	FINISH [C]
			RAL 9005
2.904.010	2.T	Elastic Polymer	07
	1B.RW510		

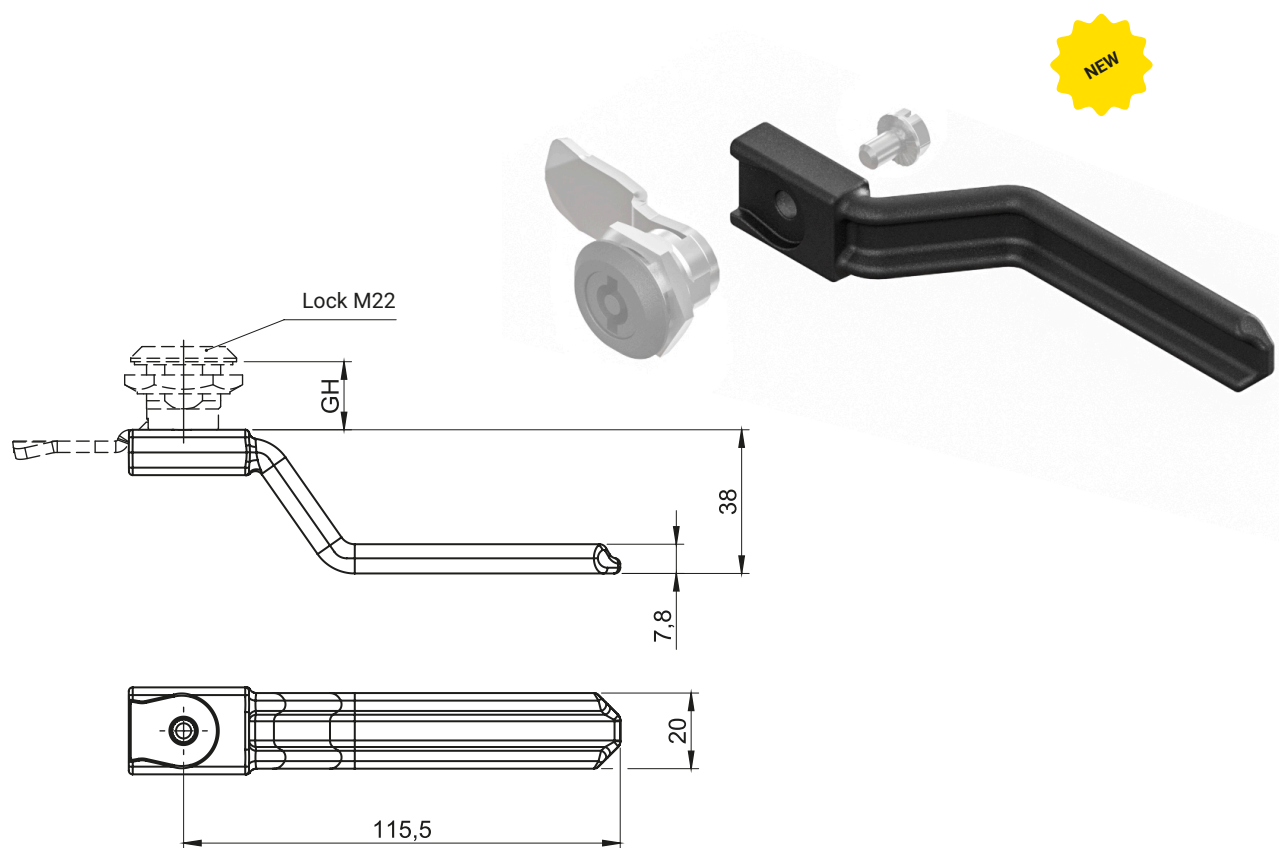

CATALOGUE NUMBER	COMPONENTS	FINISH [C]		LOCK GH VALUE
		RAL 9005	RAL 7035	
1C.DB.002	Internal handle (Polyamide PA6 GF30) Galvanized screw	07	08	18
				30
				40
				60

How to order:

Catalogue number

Finish

Height GH of the lock to which the handle is to be fitted

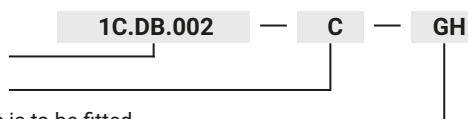

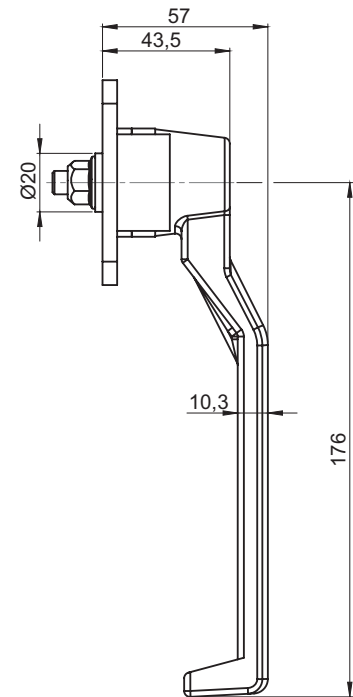
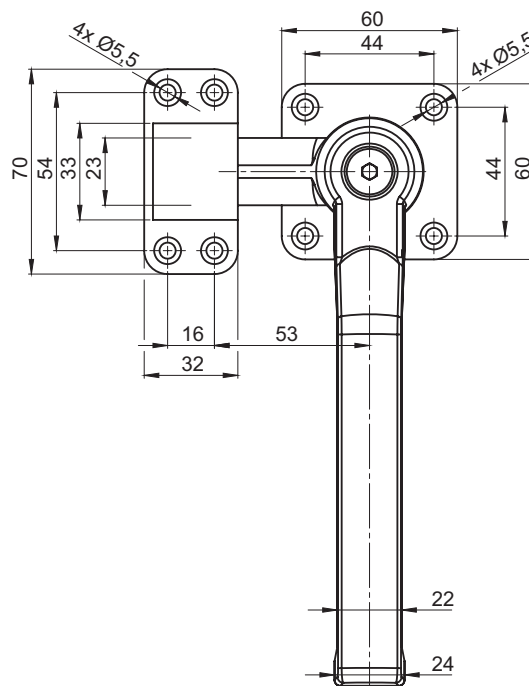
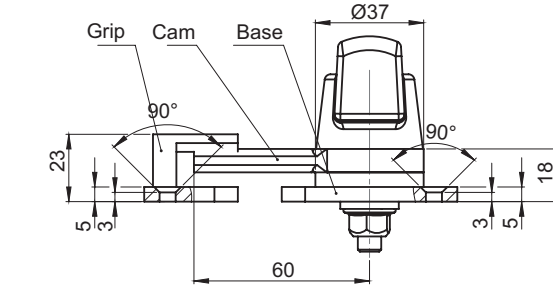

TYPE OF LOCK	COMPONENTS	MATERIAL	FINISH [C]
			RAL 9005
2.800.001	Handle	Aluminium	04
	Cam, Base, Grip	Steel zinc plated	-

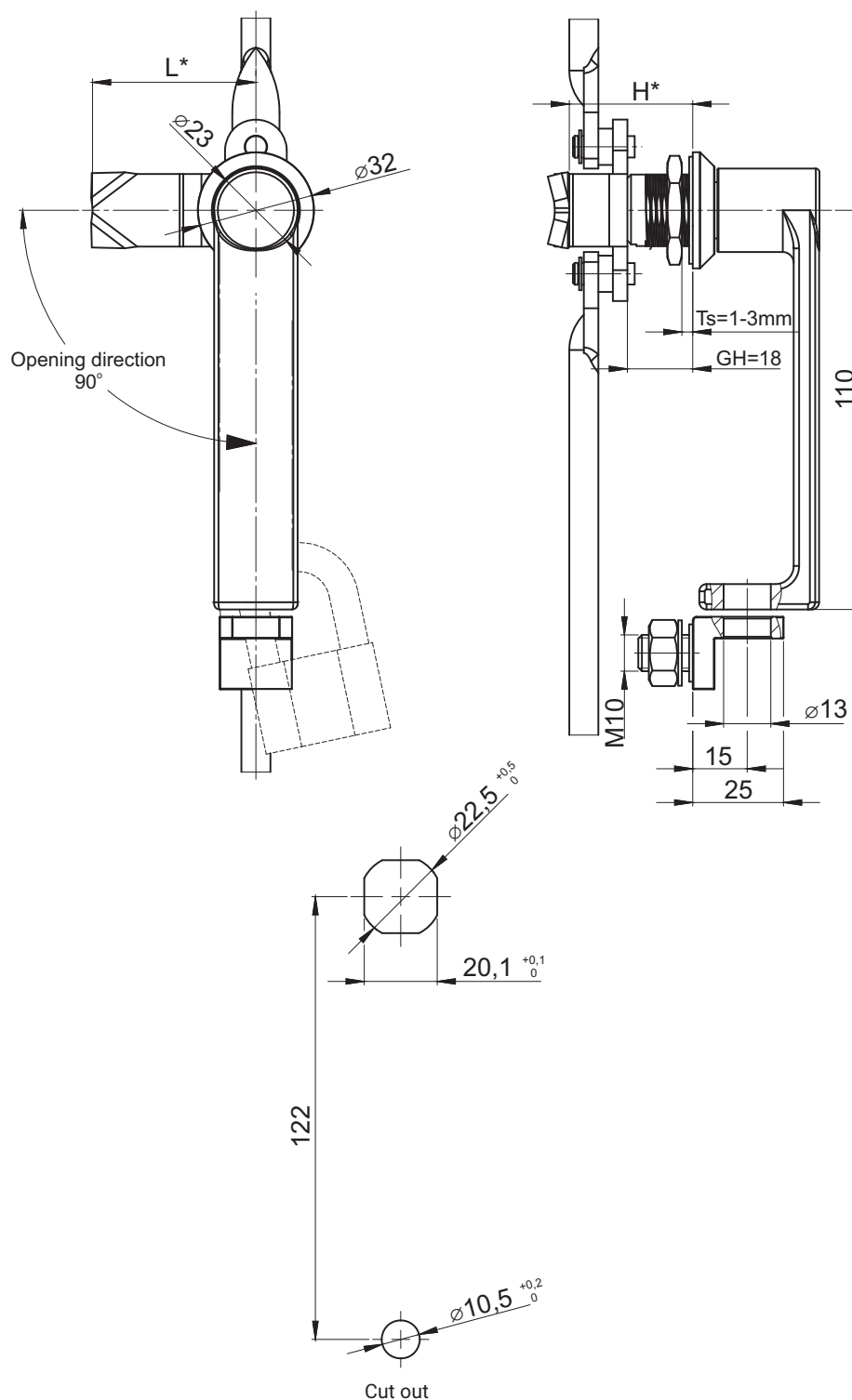

The lock fitted to cams with fasteners form the group: 12, 32, (pg. 1C-10, 1C-17)
 Rods page 1C-4, 1C-5,
 Ts - thickness of a metal sheet

CATALOGUE NO.	COMPONENTS	MATERIAL	FINISH [C]
			RAL 9005
2.540.001	Handle, Housing, Blockade	ZAMAK	04
	Cam	Zinc plated steel	-

stainless steel

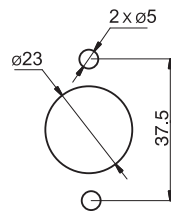
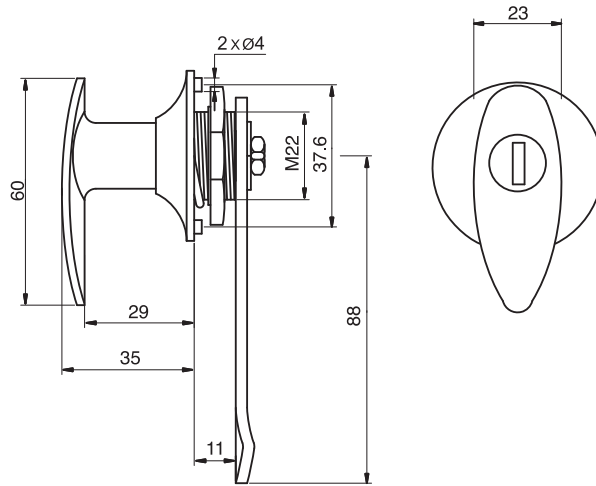

Cut out

TYPE OF LOCK	KEY CODE	COMPONENTS	MATERIAL
2.531.001	101	Housing, cam	Stainless steel
2.531.101	-	Housing, cam	Stainless steel

stainless steel

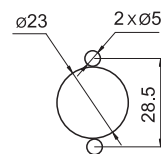
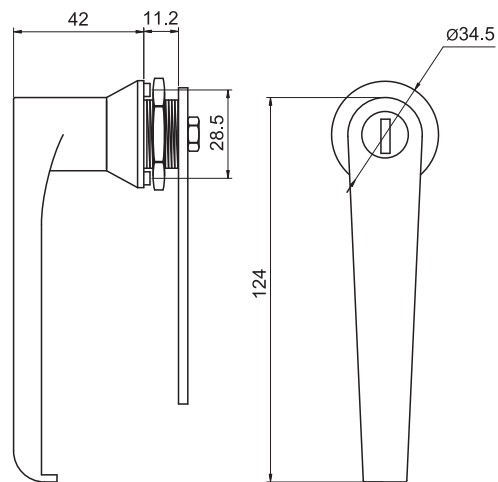

Cut out

TYPE OF LOCK	KEY CODE	COMPONENTS	MATERIAL
2.532.001	101	Housing, cam	Stainless steel
2.532.101	-	Housing, cam	Stainless steel

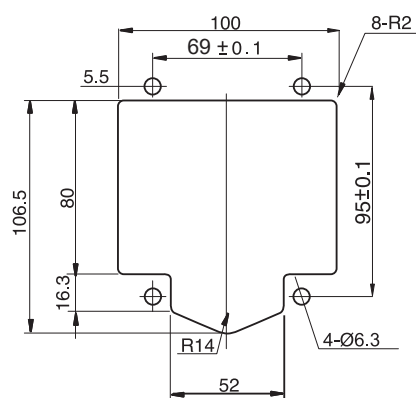
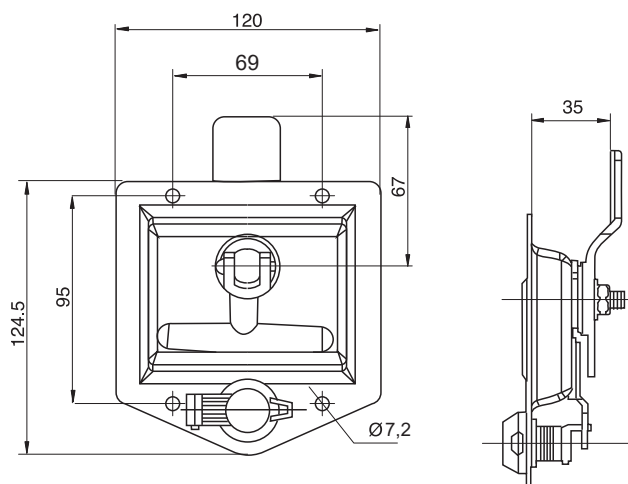

Cut out

TYPE OF LOCK	COMPONENTS	MATERIAL
2.526.001	Housing	Stainless steel
	Blocade	ZAMAK5

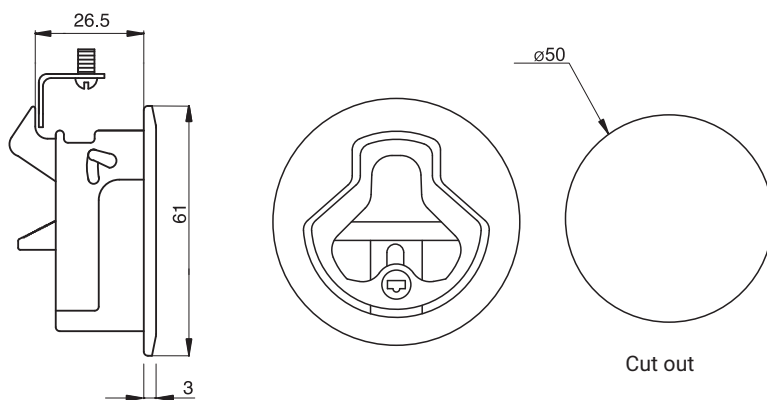

Cut out

Note:
Includes 1 pair of keys
Lock sold with cylinder

TYPE OF LOCK	COMPONENTS	MATERIAL
2.544.001	Housing	Stainless steel
	Handle	

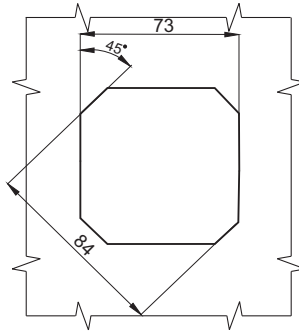
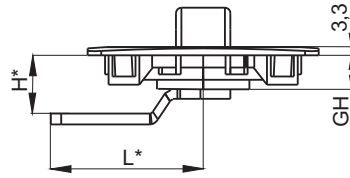

Cut out

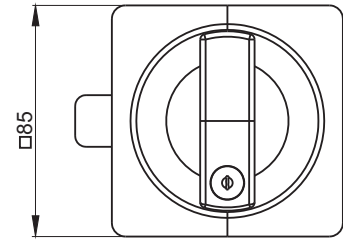

H	Cam	Cam	Cam
	1 pkt	2 pkt	3 pkt
GH=12,5			
2	601	625	631
3,5	602		632
6,5	603		633
9,5	604		634
12,5	605		635
15,5	606		636
18,5	607		637
21,5	608		638

Tab. The cam codes to order

TYPE OF LOCK	COMPONENTS	MATERIAL	FINISH [C]	
			Chrome	RAL 9005
2.608.001	Housing	Polyamide	-	07
	Handle	ZAMAK	01	-
	Cam	Steel zinc plated	-	-

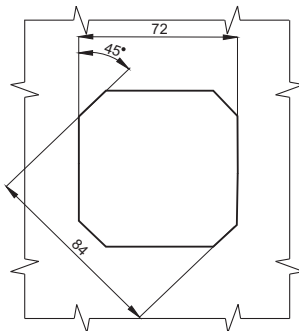
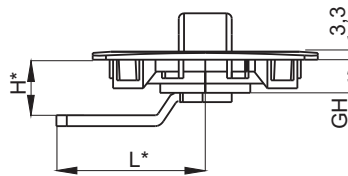

Cut out

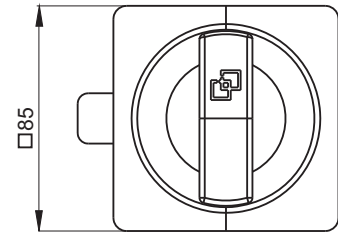

H	CAM	CAM	CAM
	1 PKT	2 PKT	3 PKT
GH=12,5			
2	601	625	631
3,5	602		632
6,5	603		633
9,5	604		634
12,5	605		635
15,5	606		636
18,5	607		637
21,5	608		638

Tab. The cam codes to order

TYPE OF LOCK	COMPONENTS	MATERIAL	FINISH [C]	
			Chrome	RAL 9005
2.609.001	Housing	Polyamide	-	07
	Handle	ZAMAK	01	-
	Cam	Steel zinc plated	-	-

* possibility to order in another dimension

How to order :

 Type of lock
 Type of cam
 Finish

2.609.001 — 601 — C

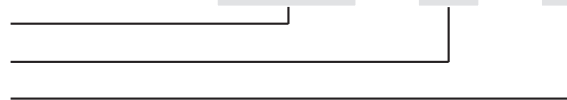

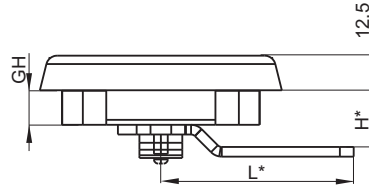
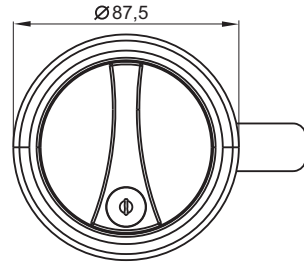

H	CAM 1 PKT	CAM 2 PKT	CAM 3 PKT
	GH=12,5		
2	601	625	631
3,5	602		632
6,5	603		633
9,5	604		634
12,5	605		635
15,5	606		636
18,5	607		637
21,5	608		638

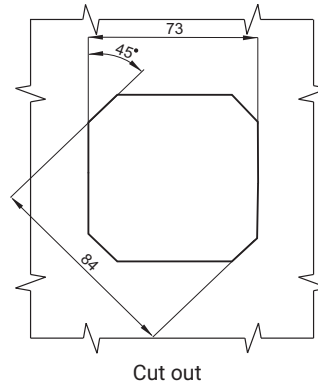

Tab.1 The cam codes to order

TYPE OF LOCK	COMPONENTS	MATERIAL	FINISH [C]	
			RAL 9005	RAL 7035
2.606.001	Housing	Polyamide	07	-
	Handle	ZAMAK5	-	05
	Cam	Steel zinc plated	-	-

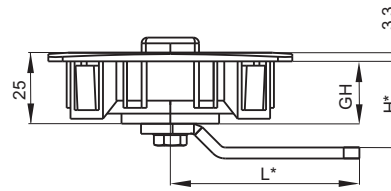
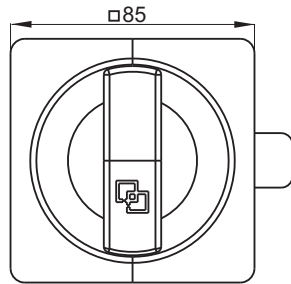

H	CAM 1 PKT	CAM 2 PKT	CAM 3 PKT
	GH=20,5		
11,2	601	625	631
12,7	602		632
15,7	603		633
18,7	604		634
21,7	605		635
24,7	606		636
27,7	607		637
30,7	608		638

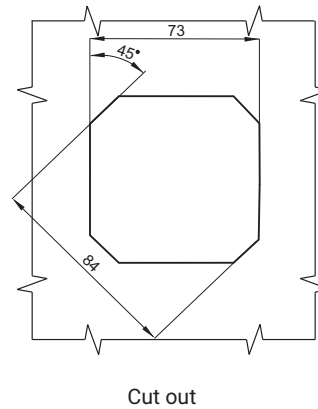

Tab.1 The cam codes to order

TYPE OF LOCK	COMPONENTS	MATERIAL	FINISH [C]	
			Chrome	RAL 9005
2.607.001	Housing	Polyamide	-	07
	Handle	ZAMAK5	01	-
	Cam	Steel zinc plated	-	-

* possibility to order in another dimension

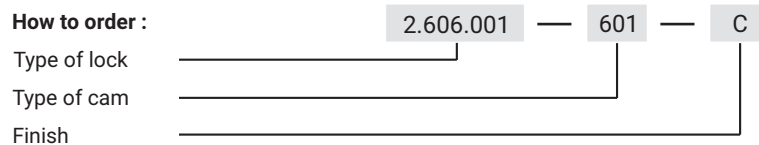



2.533.101



2.533.001

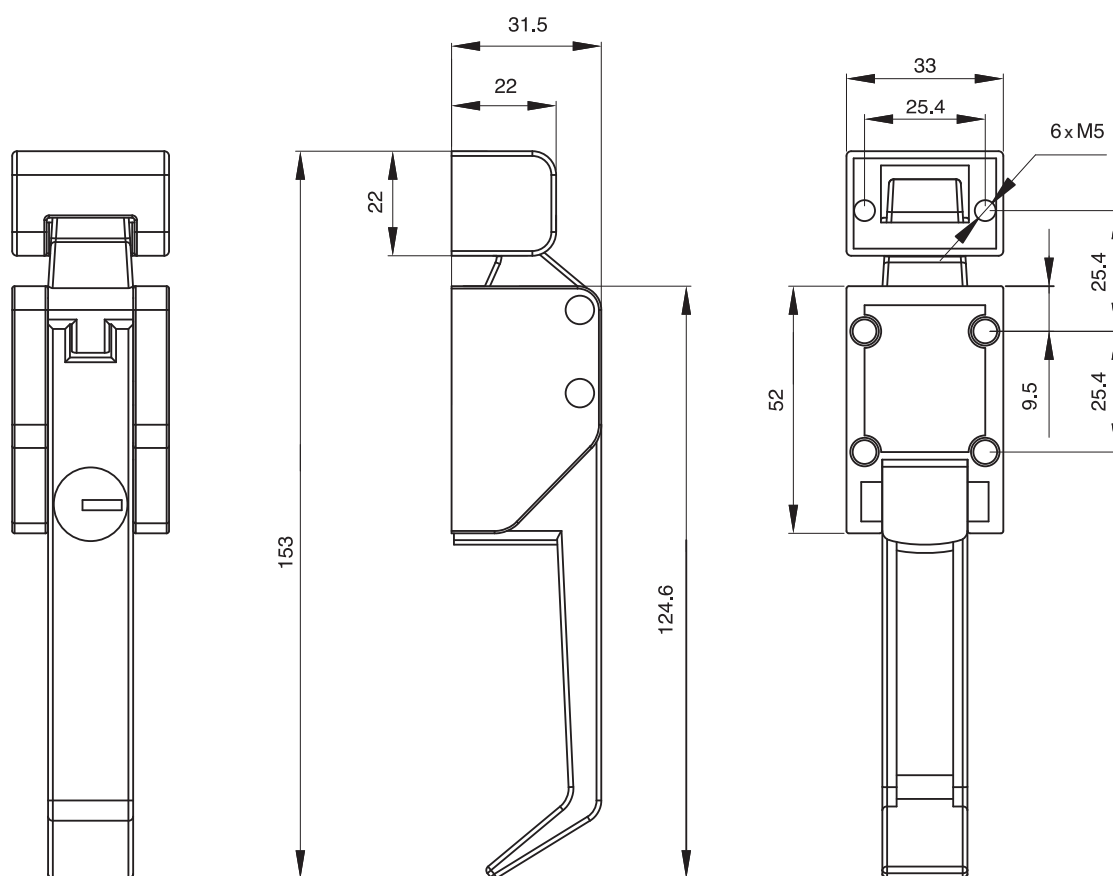

TYPE OF LOCK	COMPONENTS	MATERIAL	FINISH [C]
			RAL 9005
2.533.001	Housing	ZAMAK 5	04
2.533.101*			

* lock with patent insert

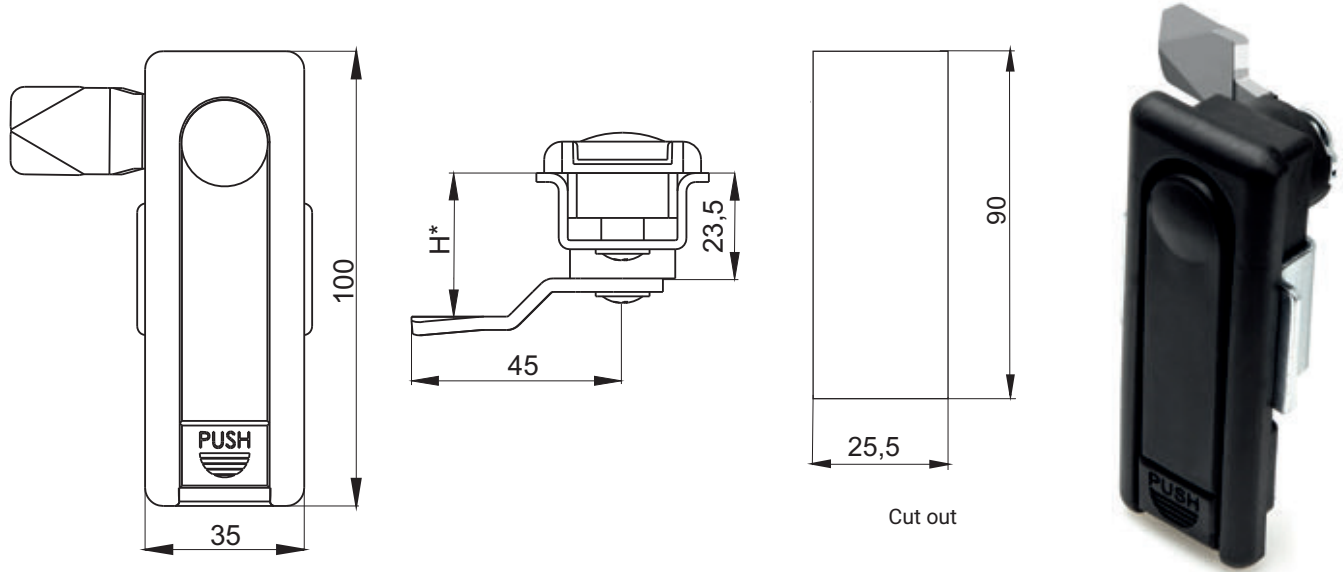

* By ordering specify the size H lock cam.

TYPE OF LOCK	COMPONENTS	MATERIAL	FINISH [C]
			RAL 9005
2.604.001	Housing, handle	Polyamide	07
	Cam	Stainless steel	-

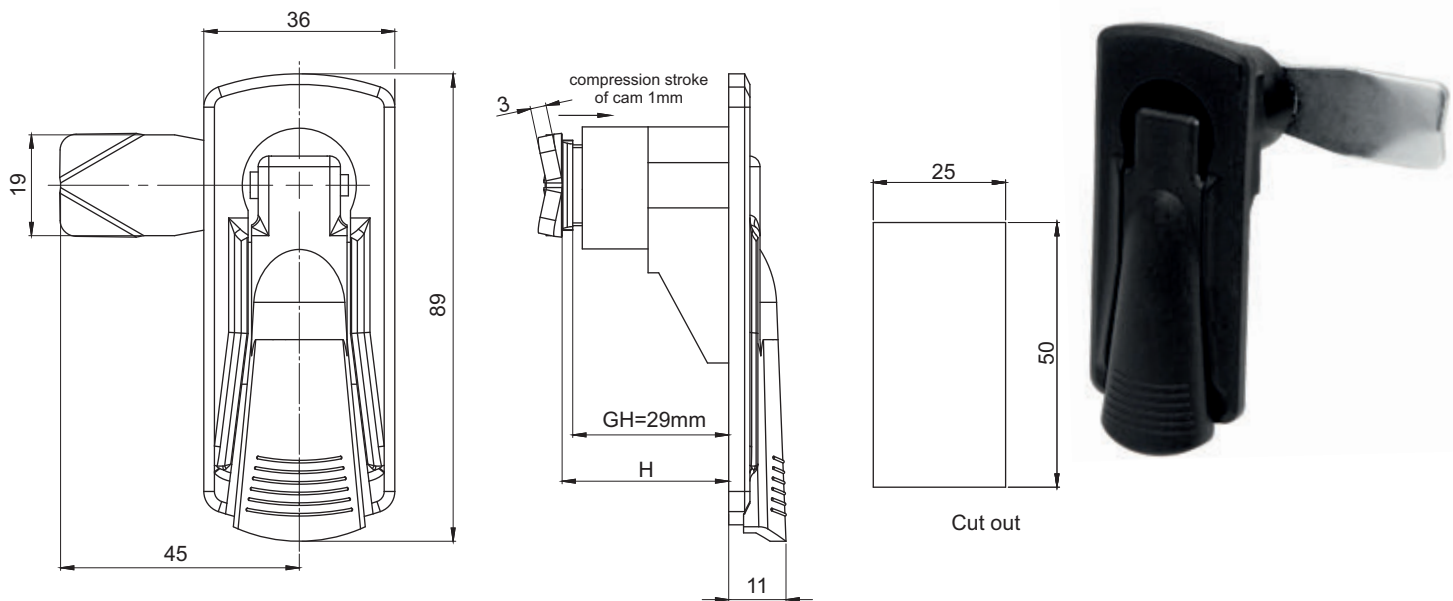

TYPE OF LOCK	COMPONENTS	MATERIAL	FINISH [C]
			RAL 9005
2.605.001	Handle, Housing	Polyamide	07
	Cam	Zinc plated steel	-

How to order :

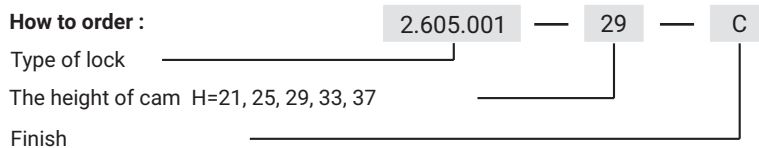

The lock has the stroke of the cam offsetting the clearance.

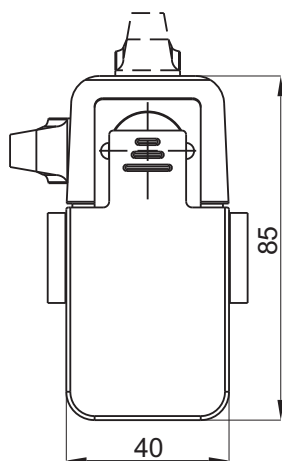

2.613.00.000

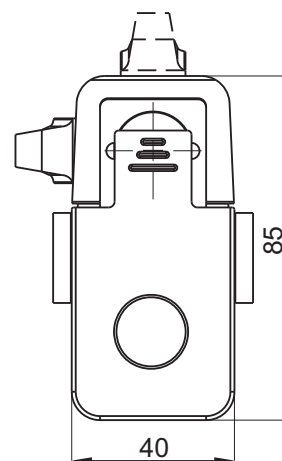

2.613.11.000

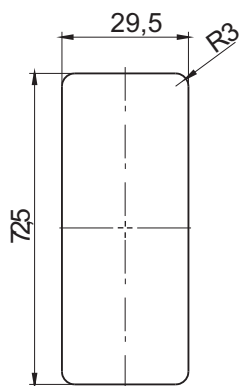

Cut out

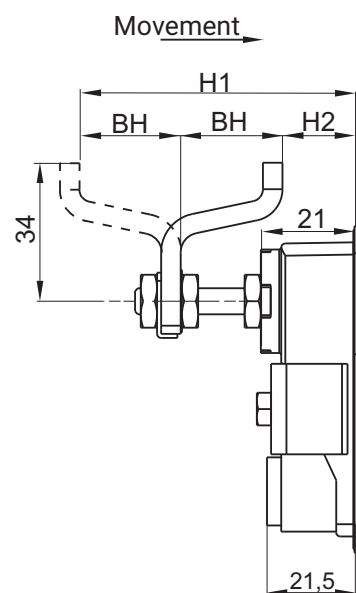

TYPE OF CYLINDER	CATALOGUE NUMBER				THE RANGE OF CAM	
	RAL 9005	04	Chrome	01	H2	H1
Without cylinder	2.613.00.110		2.613.00.130		6-16	56-66
	2.613.00.210		2.613.00.230		16-26	46-56
	2.613.00.310		2.613.00.330		26-36	56-46
Screwdriver	2.613.11.110		2.613.11.130		6-16	56-66
	2.613.11.210		2.613.11.230		16-26	46-56
	2.613.11.310		2.613.11.330		26-36	56-46
NAME	COMPONENTS			MATERIAL		
2.613.00.000	Housing, handle			ZAMAK5		
	Cam			Steel zinc plated		

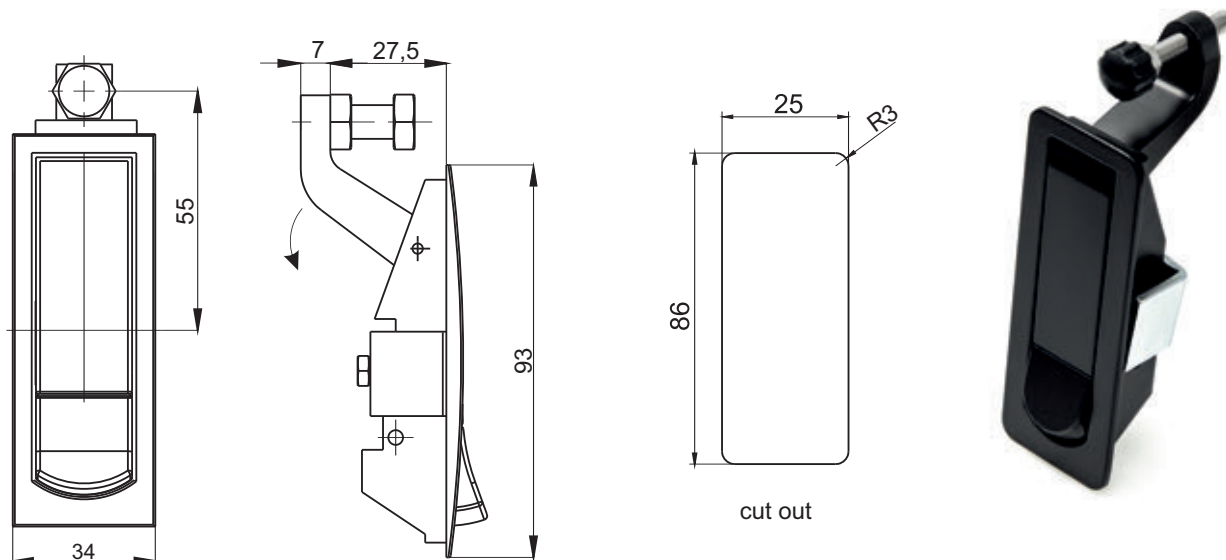

CATALOGUE NUMBER	TYPE OF LOCK	COMPONENTS	MATERIAL	FINISH [C]	
				Chrome	RAL 9005
2.615.146.10	With cylinder	Housing	ZAMAK 5	-	04
2.615.346.10	Without cylinder				
2.615.146.30	With cylinder	Housing	ZAMAK 5	01	-
2.615.346.30	Without cylinder				

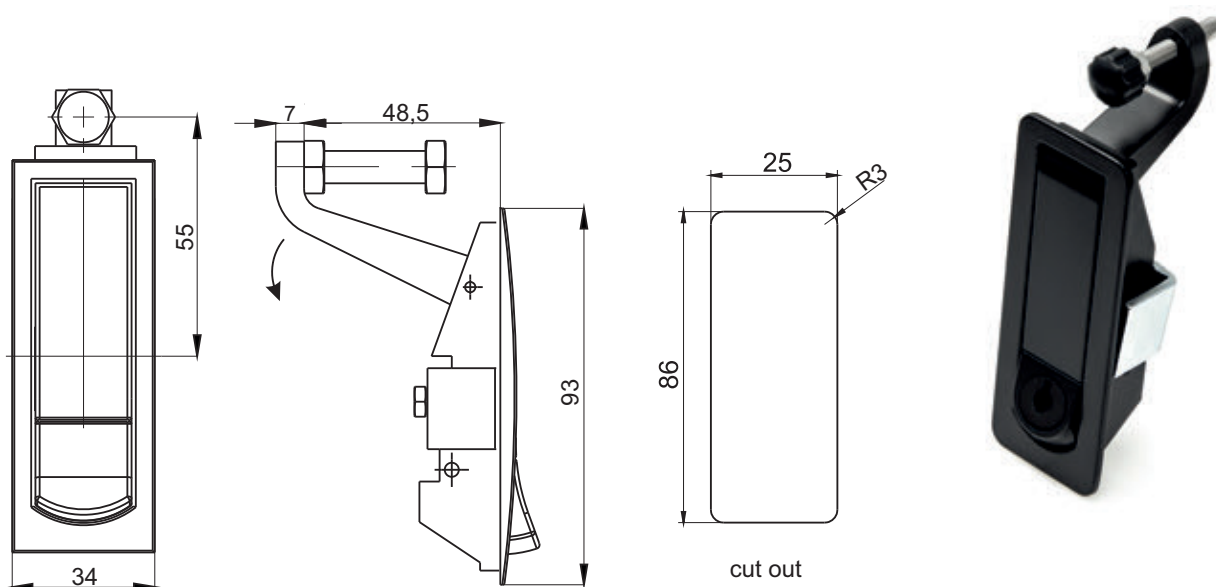

CATALOGUE NUMBER	TYPE OF LOCK	COMPONENTS	MATERIAL	FINISH [C]	
				Chrome	RAL 9005
2.615.124.10	With cylinder	Housing	ZAMAK 5	-	04
2.615.324.10	Without cylinder				
2.615.124.30	With cylinder	Housing	ZAMAK 5	01	-
2.615.324.30	Without cylinder				

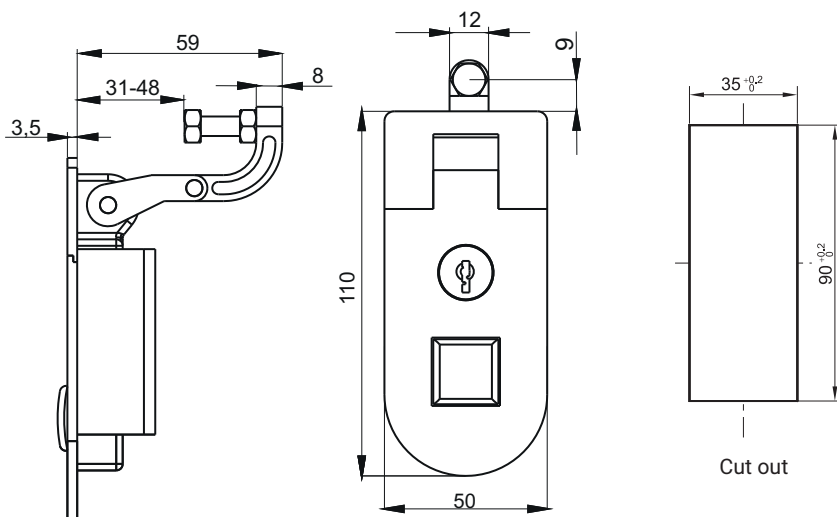

TYPE OF LOCK	COMPONENTS	MATERIAL	FINISH [C]
			2.601.001

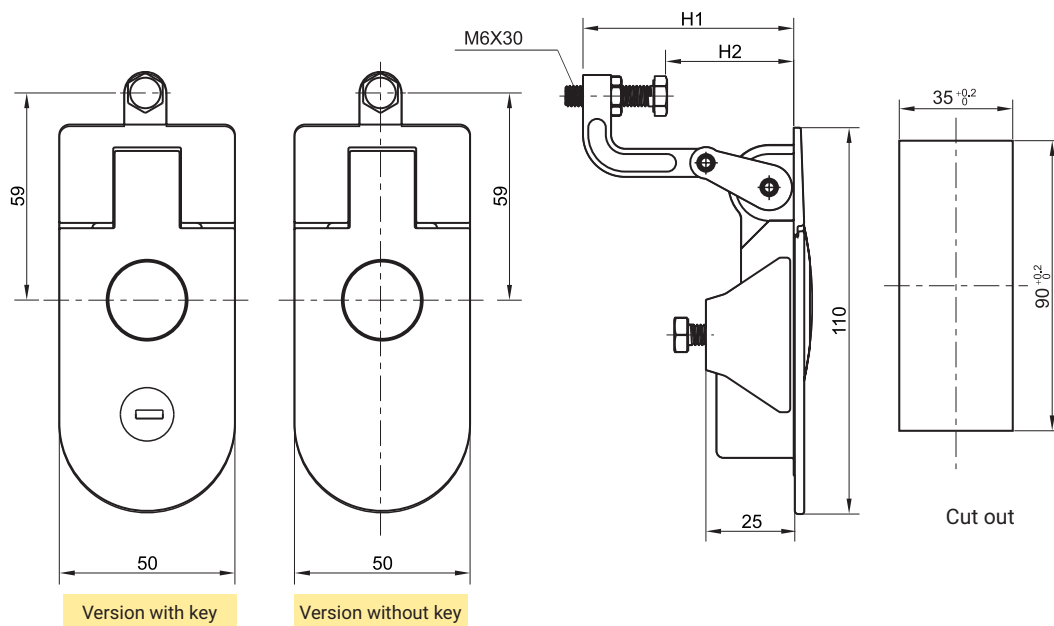

TYPE OF LOCK with key	TYPE OF LOCK without key	DIMENSION		COMPONENTS	MATERIAL	FINISH [C]
		H1	H2			RAL 9005
2.601.101	2.601.201	29	0-15	Housing, Handle	ZAMAK5	04
2.601.102	2.601.202	60	30-45			
2.601.103	2.601.203	43	15-30			
2.601.104	2.601.204	75	45-60			

How to order:
 Type of lock
 Dimension H1
 Finish [C]



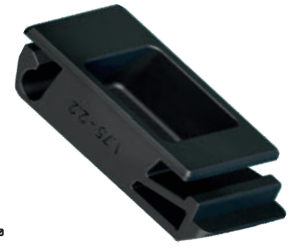
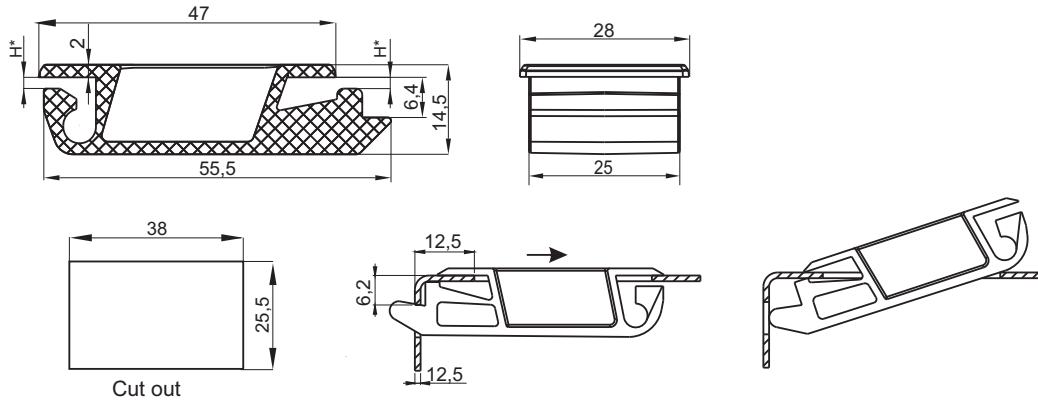

Closing snap :

-5.509.001A dedicated to sheet thickness 1,2 mm-1,6 mm

-5.509.001B dedicated to sheet thickness 1,75 mm-2,2 mm

TYPE OF LOCK	DIMENSION [H]	FINISH & MATERIAL [C]	
		RAL9005 - ABS	RAL7035 - PA6
2.509.001A	1,8	07	08
2.509.001B	2,5		

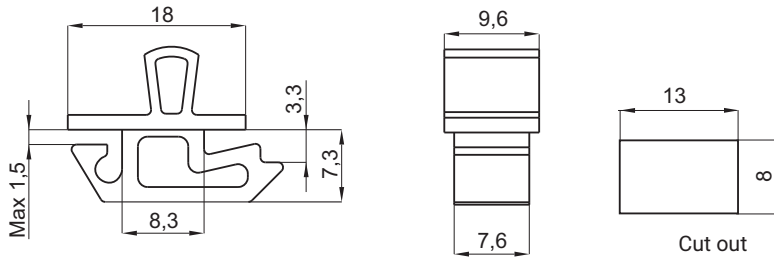

Closing snap:

-5.509.002 dedicated to sheet thickness 1 mm - 1,5 mm

TYPE OF LOCK	COMPONENTS	MATERIAL	FINISH [C]	
			RAL9005	RAL7035
2.509.002	Housing	Polyamide	07	08

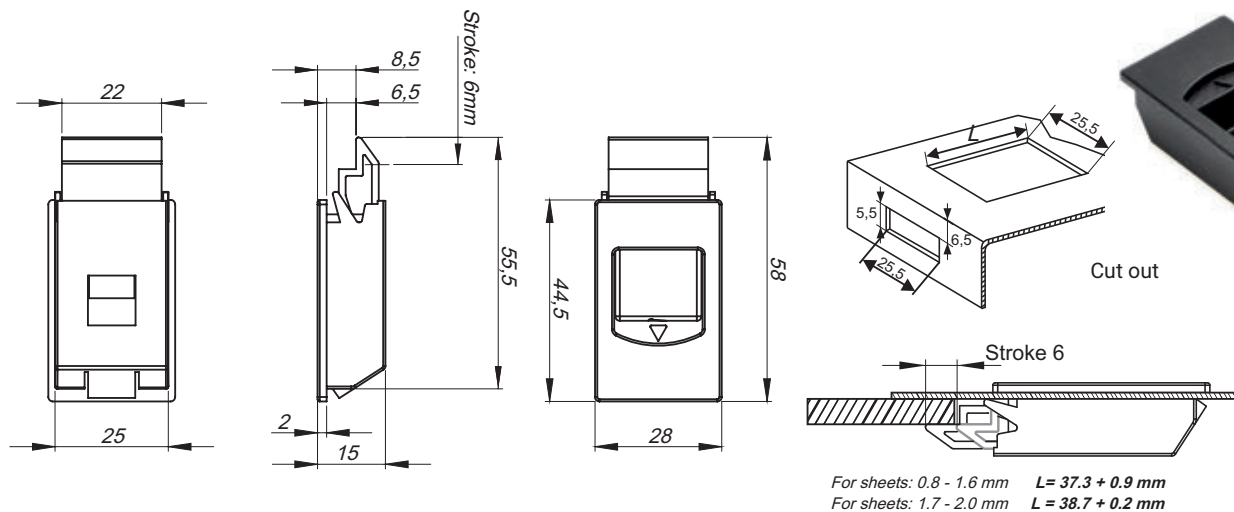

TYPE OF LOCK	COMPONENTS	MATERIAL	FINISH [C]	
			RAL9005	RAL7035
2.509.003	Housing, sliding portion	Polyamide	07	08

How to order :

Type of lock

Finish

2.509.001A — C

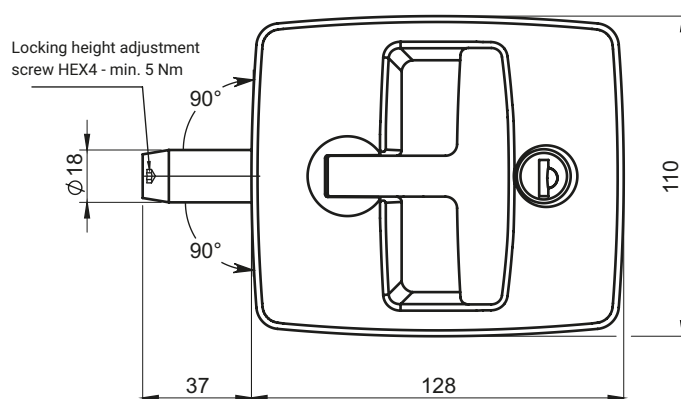
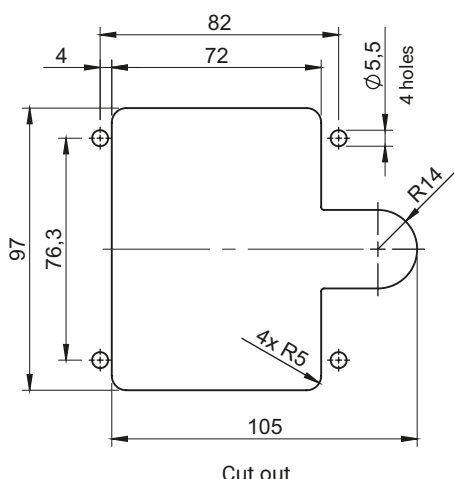
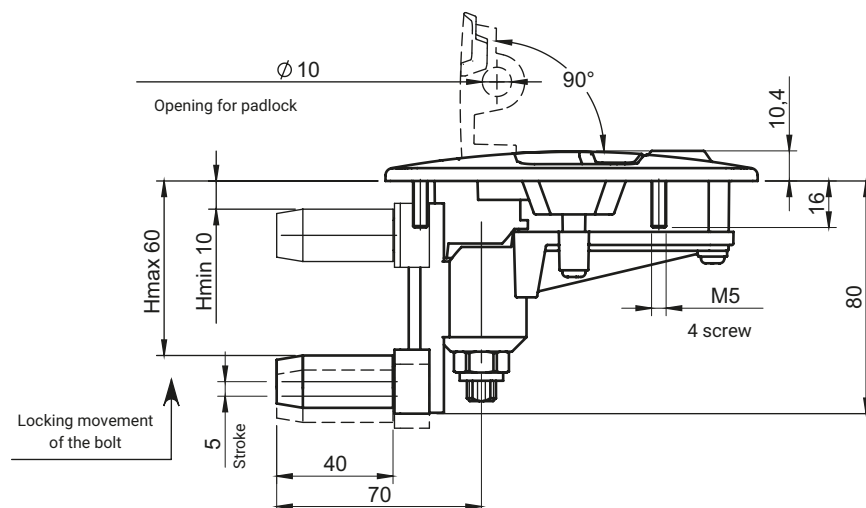

Sealing of lockable doors by folding the lock handle into the lock body.
 The locking height (dimension H) is adjustable from 10 to 60 mm.
 Locking height is adjusted when the lock is installed and locked with the HEX 4 key
 - Recommended tightening torque for the adjusting screw: 5 Nm.

TYPE OF LOCK	COMPONENTS	MATERIAL	FINISH [C]		CYLINDER PROFILE	
			Chrome	RAL9005	Key code	
2.516.001	Housing, Lever Roller	Polyamide PA6 GF	-	07	Different code RK	1333
	Handle	ZAMAK	01	04		
	Bolt, Lever Bushing	ZAMAK	-	-		

INSERTS				FINISH [C]	
D5	T9	KW 8	S	Chrome	RAL9005*
				01	04

How to order:

Catalogue no.
 Key code / Type of insert [C]
 where: C - type of insert surface finish
 Housing finish [C]
 Handle finish [C]

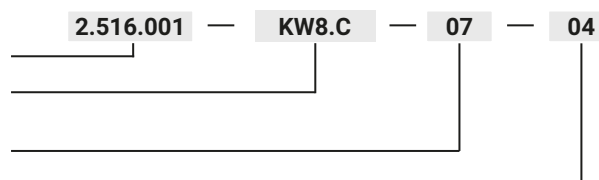

* other colours on request



IP65

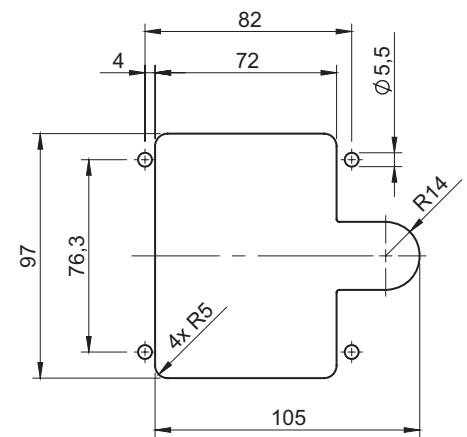
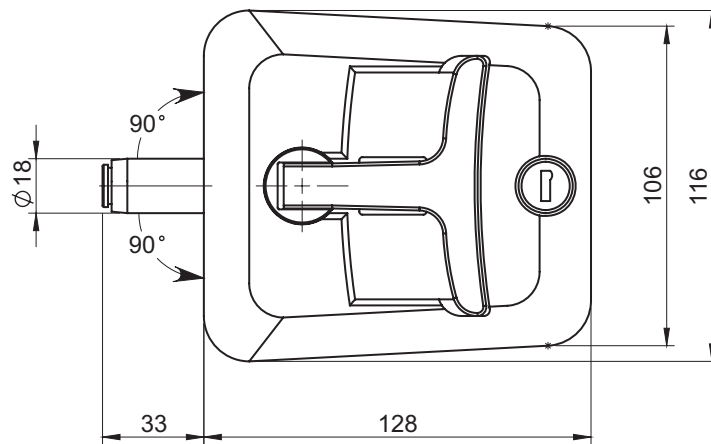
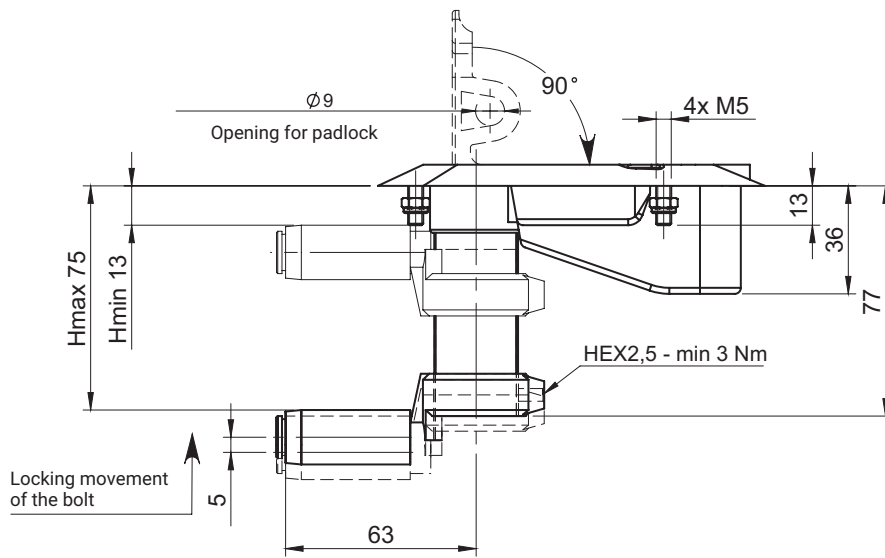

Cut out

Sealing of the closed door through the axial rotation of the bushing along with the bolt, and fixing the lock in the closed position occurs when the lock handle is folded into its body.
 The position of the bolt (dimension H) is adjustable in the range from 13 to 75 mm.
 The position of the bolt on the bolt bushing is determined during assembly and then fixed with a 2.5 mm HEX key - the minimum recommended tightening torque is 3 Nm.
 The lock handle is available in two colors: black (RAL 9005) and grey (RAL 7035).

TYPE OF LOCK	COMPONENTS	MATERIAL	FINISH [C]	
			RAL9005	RAL7035
2.515.001	Housing, Lever Roller	Polyamide PA6 GF	07	-
	Handle	ZAMAK	04	05
	Bolt, Lever Bushing	ZAMAK	-	-

How to order:

Catalogue no.
 Housing finish
 Handle finish

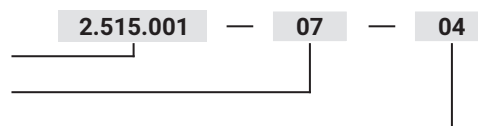

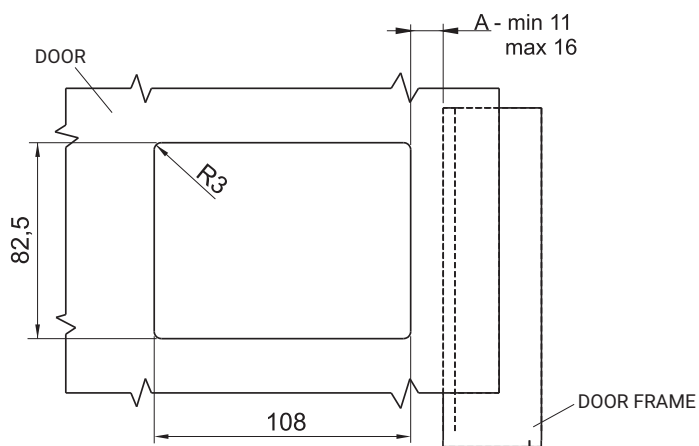
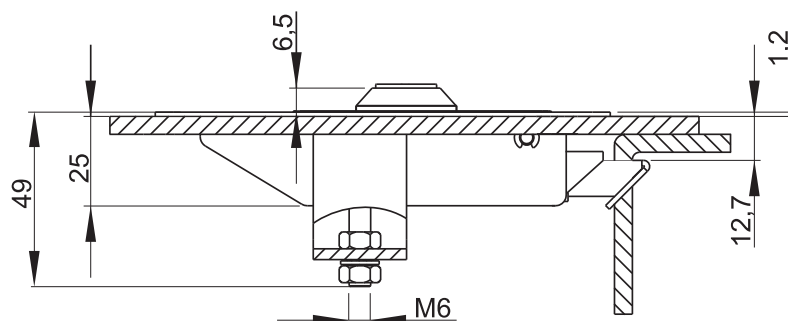
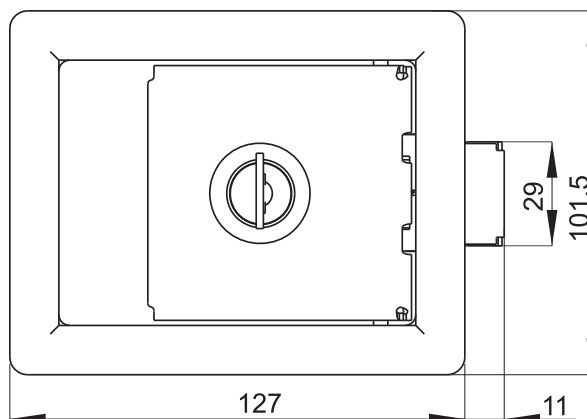

Cut out

TYPE OF LOCK	COMPONENTS	MATERIAL	FINISH [C]
			RAL 9005
2.511.001	Housing	Steel zinc plated	04
	Gasket	Elastomer	
2.511.001SN	Housing	Stainless steel	-
	Gasket	Elastomer	

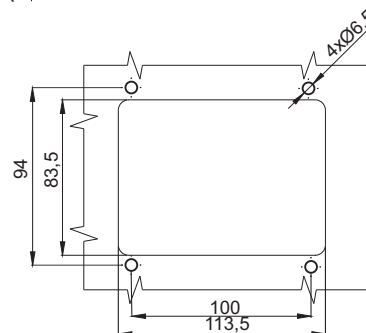
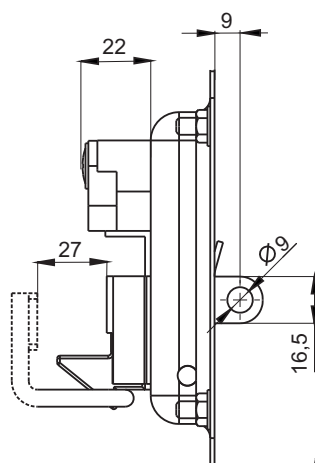
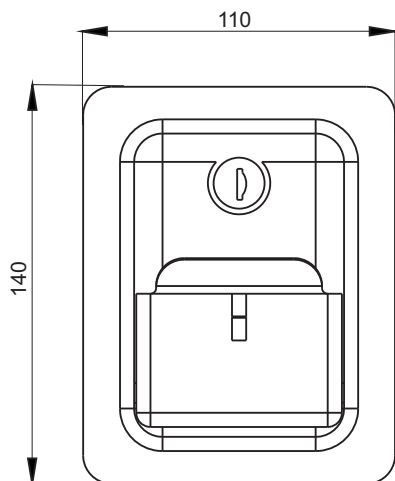

Cut out

TYPE OF LOCK	COMPONENTS	MATERIAL	FINISH [C]
			RAL 9005
2.610.001	Housing	Steel zinc plated	04
	Gasket	Elastomer	

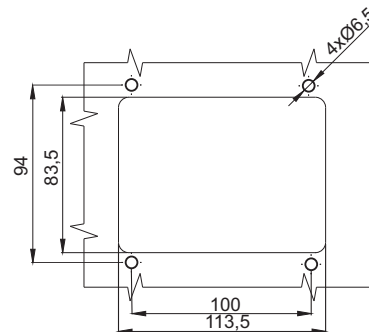
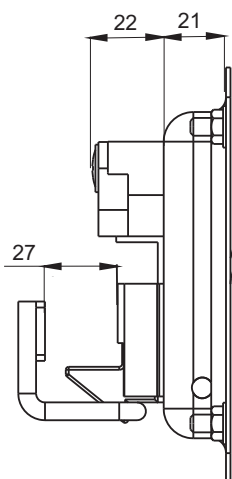
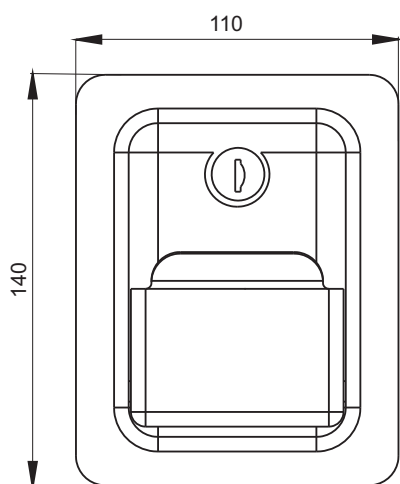

Cut out

TYPE OF LOCK	COMPONENTS	MATERIAL	FINISH [C]
			RAL 9005
2.610.002	Housing	Stainless steel	04
	Gasket	Elastomer	

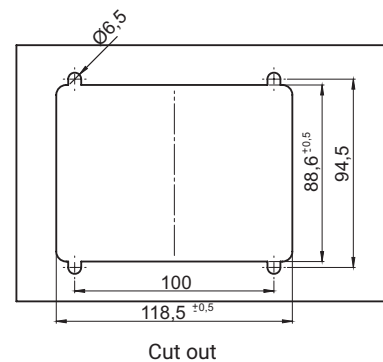
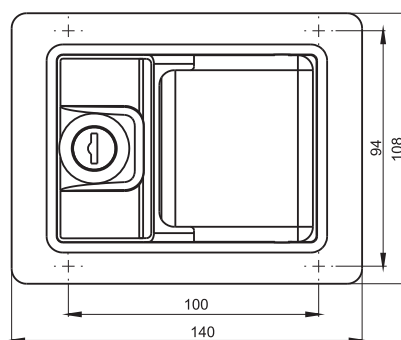
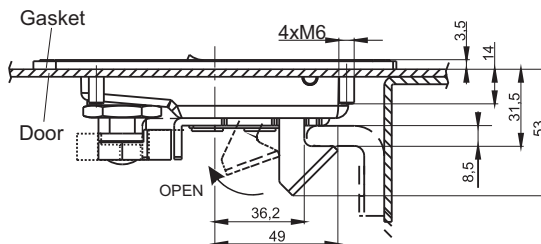

TYPE OF LOCK	COMPONENTS	MATERIAL	FINISH [C]
			RAL 9005
2.510.001	Housing	Steel zinc plated	04
	Gasket	Elastomer	

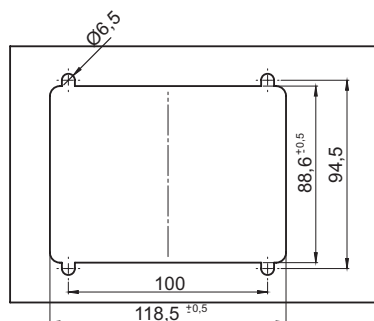
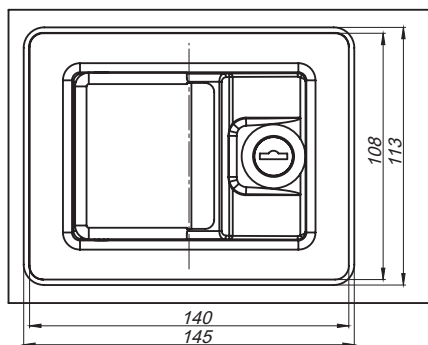
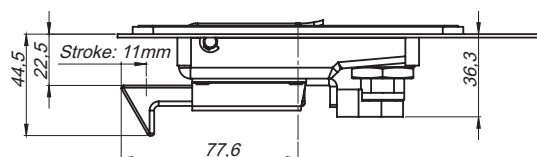

Cut out

TYPE OF LOCK	COMPONENTS	MATERIAL	FINISH [C]
			RAL 9005
2.510.003	Housing	Steel zinc plated	04
	Gasket	Elastomer	

Lock 2.510

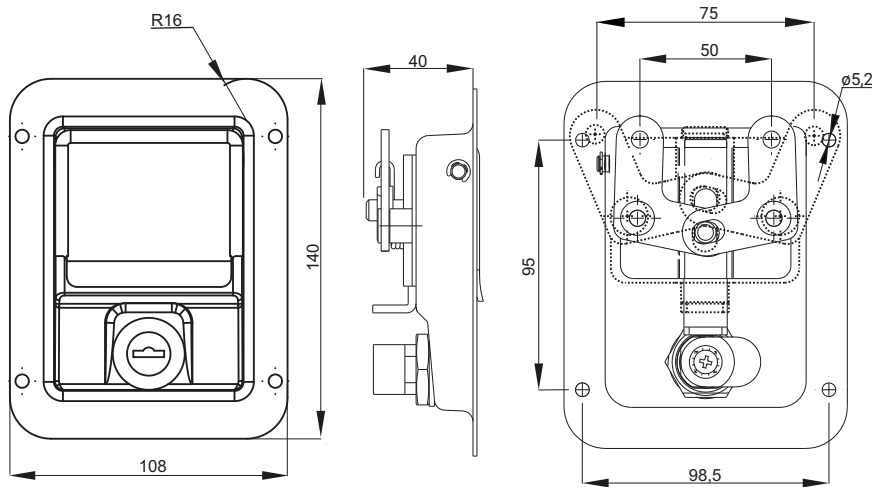

TYPE OF LOCK	COMPONENTS	MATERIAL	FINISH [C]
2.510.002	Housing	Stainless steel	RAL 9005
	Gasket	Elastomer	04

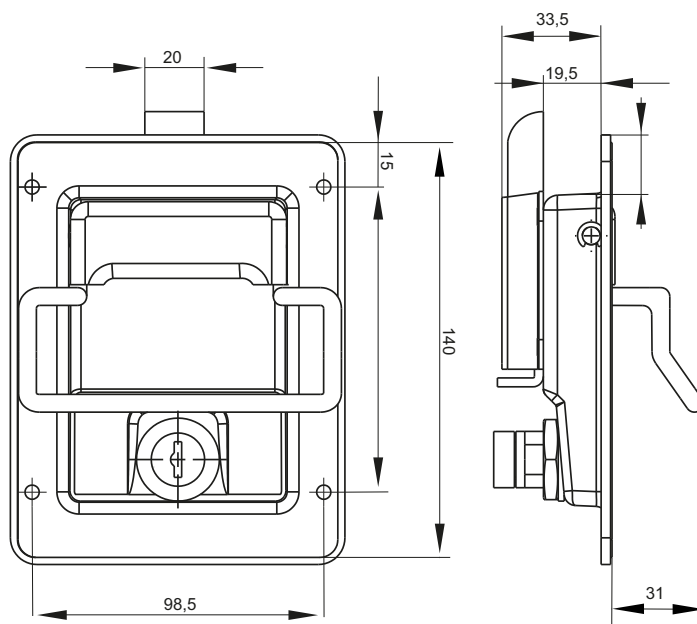

TYPE OF LOCK	COMPONENTS	MATERIAL	FINISH [C]
2.510.005	Housing	Stainless steel	RAL 9005
	Gasket	Elastomer	04

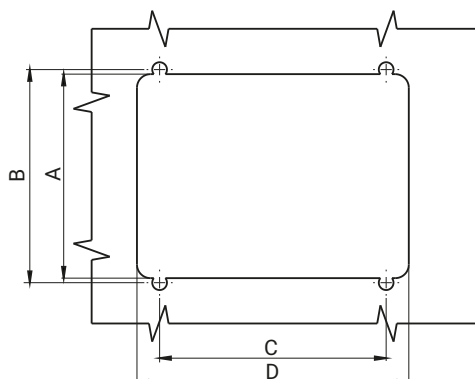

Cut out

NR	Dimension [mm]			
	A	B	C	D
2.510.002	90	95	98	120
2.510.005	80	98,5	103	113,5

stainless steel

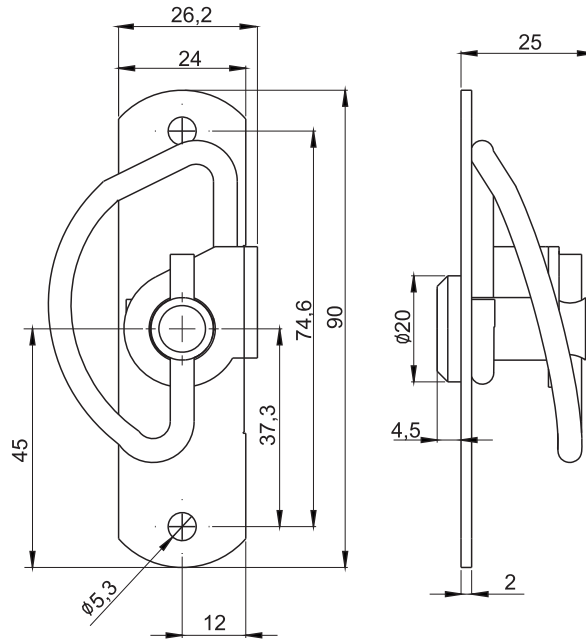

Inserts



TYPE OF LOCK	COMPONENTS	MATERIAL
2.504.001	Housing, insert	Stainless steel
	Spring	

stainless steel

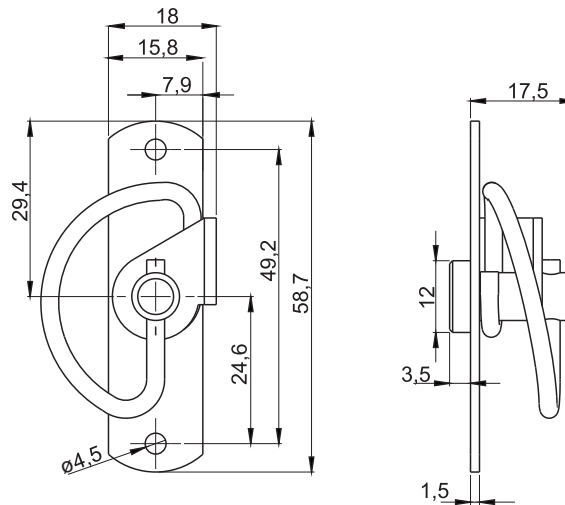

TYPE OF LOCK	COMPONENTS	MATERIAL
2.504.002	Housing, insert	Stainless steel
	Spring	

How to order :

Type of lock
Type of insert

2.504.001 — KW8

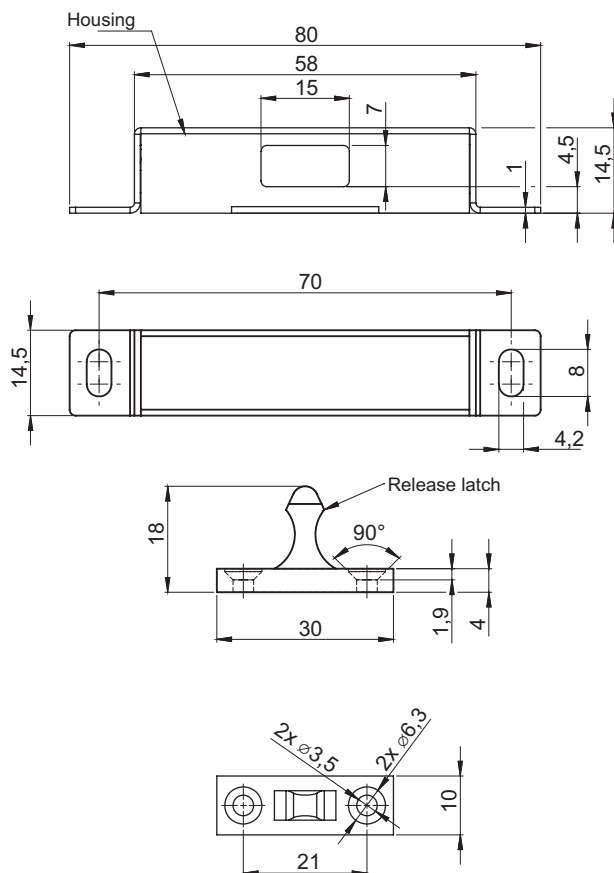

TYPE OF LOCK	DETAIL	COMPONENTS	MATERIAL
2.200.001	Roller latch	Housing	Zinc plated steel
		Release latch	POM

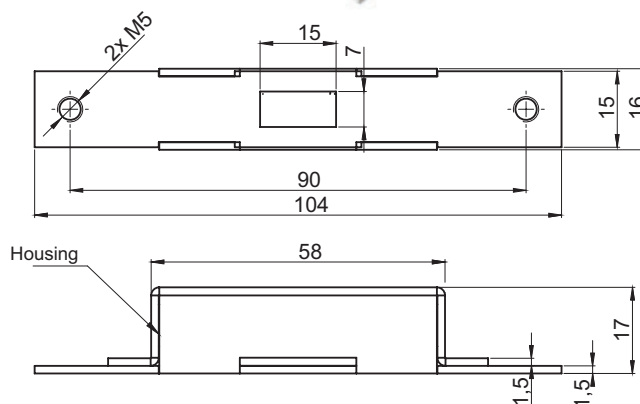
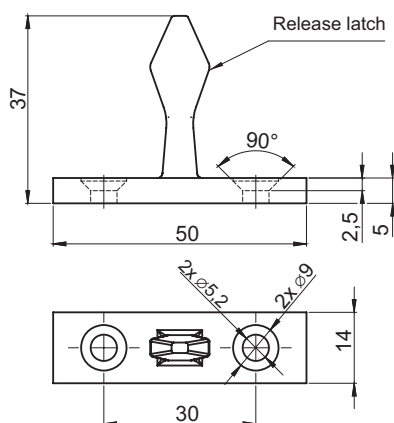

TYPE OF LOCK	DETAIL	COMPONENTS	MATERIAL
2.210.001SN	Roller latch	Housing	Stainless steel
		Release latch	POM

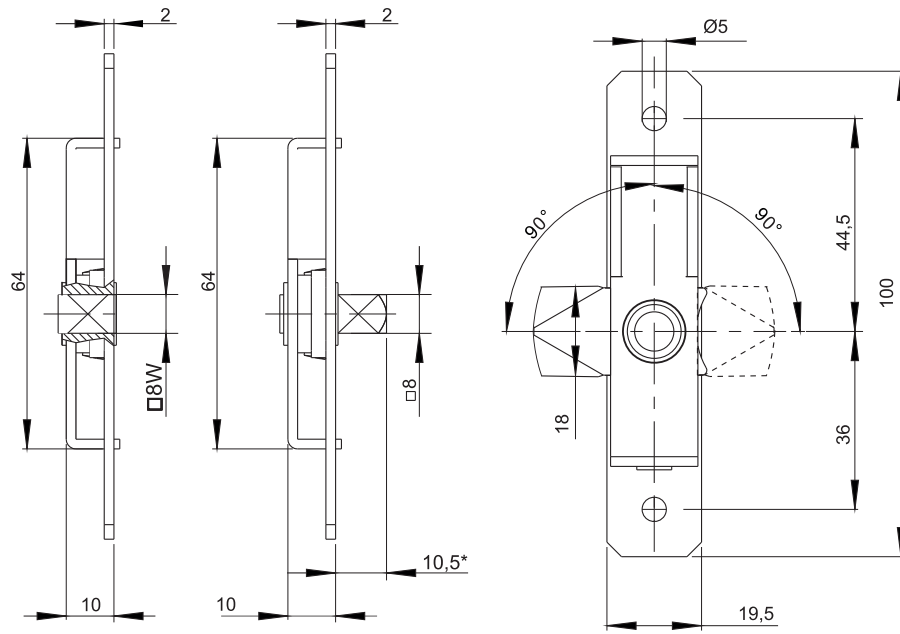

2.521.004

2.521.001

CATALOGUE NUMBER	COMPONENTS	MATERIAL
2.521.001	Housing, Insert, Cam	Steel zinc plated
2.521.004	Housing, Insert, Cam	Stainless steel

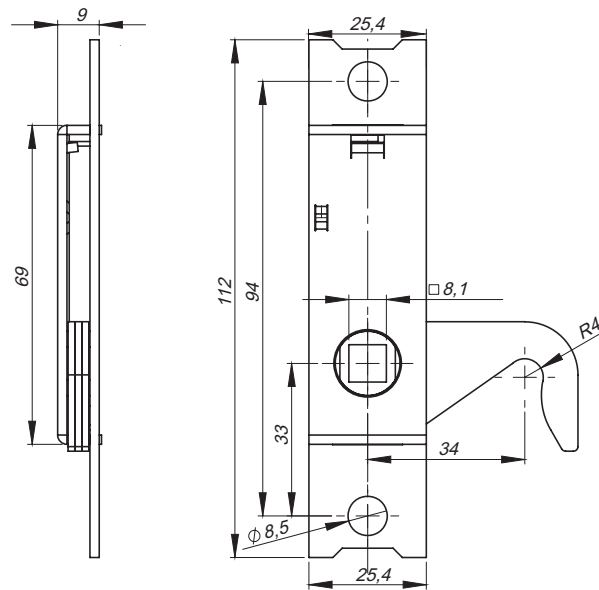

CATALOGUE NUMBER	COMPONENTS	MATERIAL
2.505.001	The base of the cam	Steel zinc plated
	The hook cam	Steel zinc plated
	The spring of the lock	Stainless steel

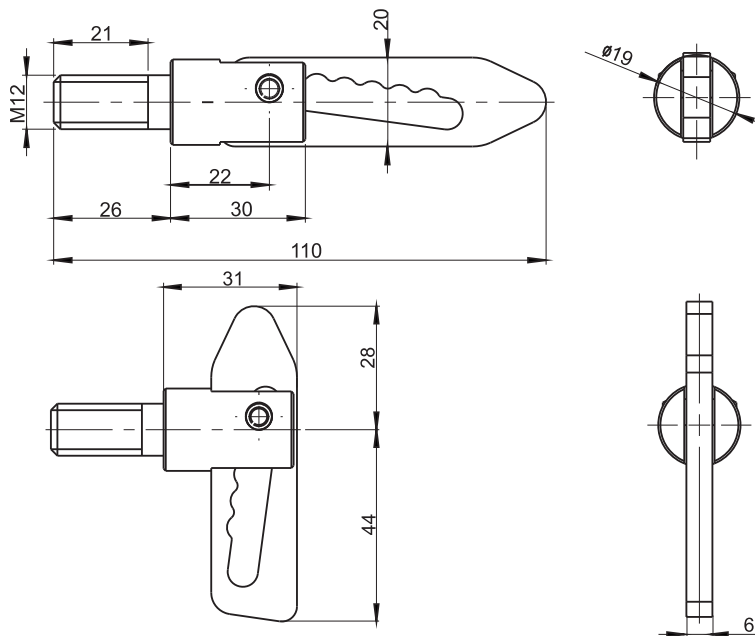

TYPE OF LOCK	COMPONENTS	MATERIAL
2.503.002	Insert, holdfast	Steel zinc plated
2.503.002SN	Insert, holdfast	Stainless steel

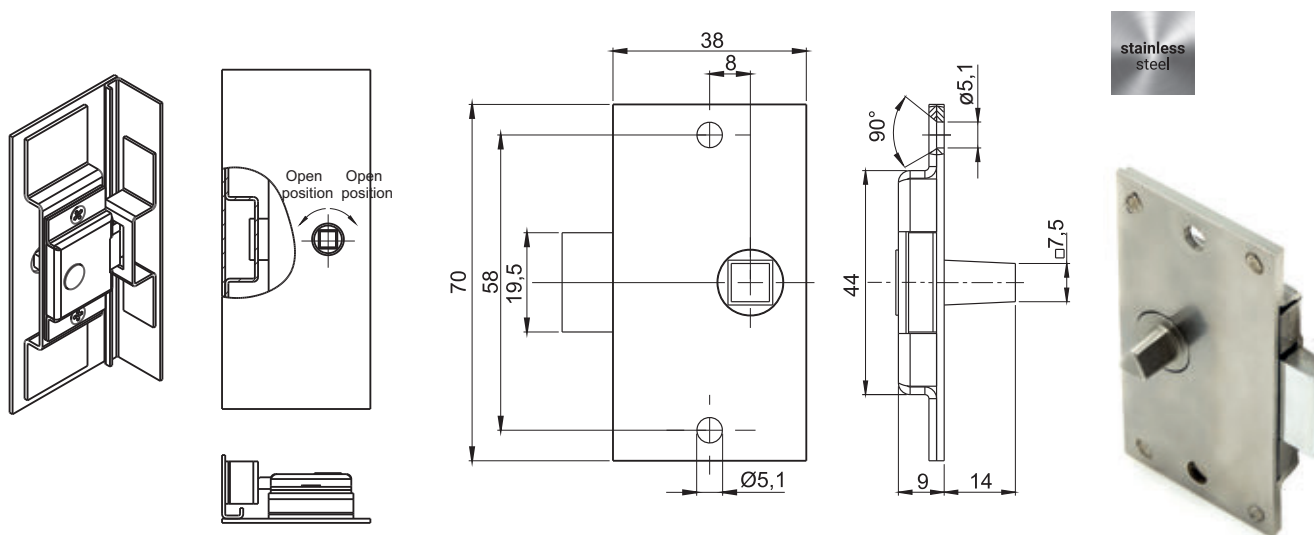

INSERT		
KW8-14	KW8-8	T8-9
TYPE OF LOCK	COMPONENTS	MATERIAL
2.520.001SN	Housing, insert Cam	Stainless steel

How to order :

Type of lock or catalogue number 2.520 — T8 — 9

Type of insert _____

Height cam H _____

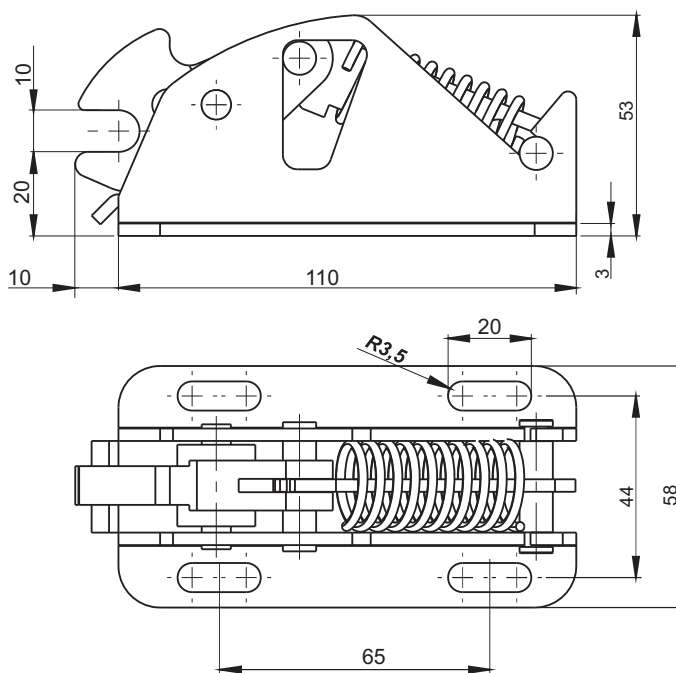

TYPE OF LOCK	COMPONENTS	MATERIAL
2.501.001	Housing / cam	Steel zinc plated/ Polyamide
2.501.001SN	Housing / cam	Stainless steel/ Polyamide

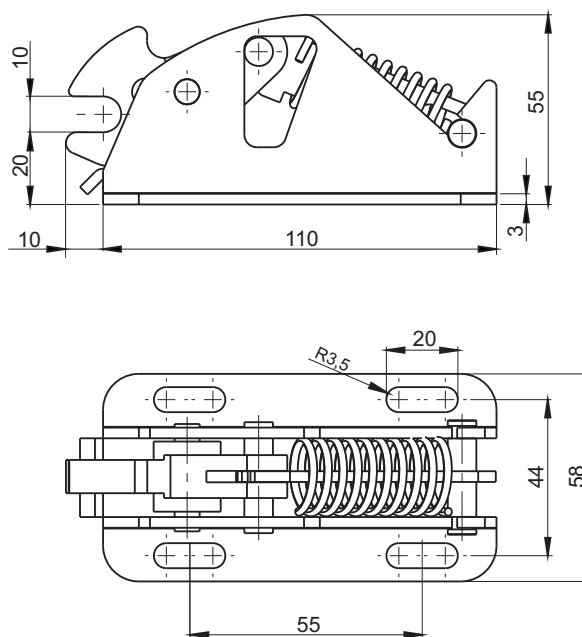

TYPE OF LOCK	COMPONENTS	MATERIAL
2.501.003	Housing / cam	Steel zinc plated/ Polyamide
2.501.003SN	Housing / cam	Stainless steel/ Polyamide

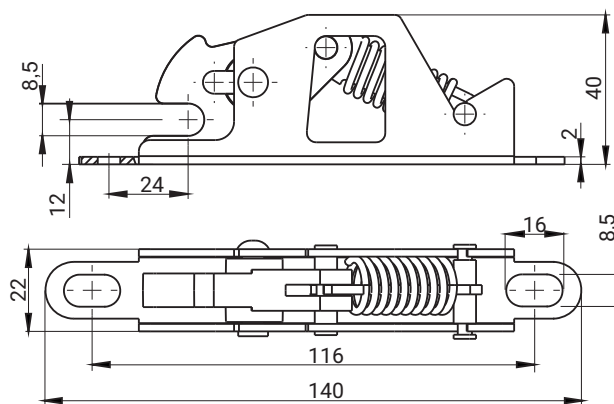

TYPE OF LOCK	COMPONENTS	MATERIAL
2.512.001	Housing / Cam	Steel zinc plated / Polyamide
2.512.001SN	Housing / Cam	Stainless Steel / Polyamide

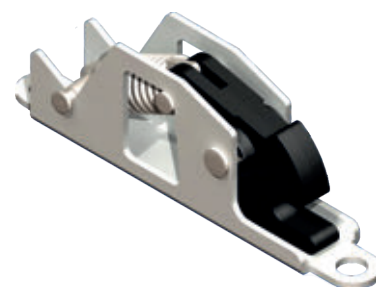
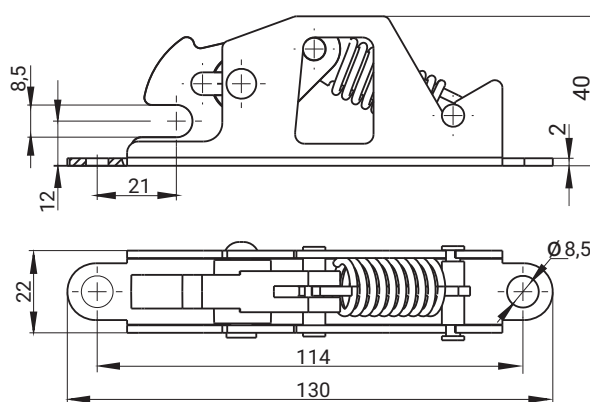

TYPE OF LOCK	COMPONENTS	MATERIAL
2.512.002	Housing / Cam	Steel zinc plated / Polyamide
2.512.002SN	Housing / Cam	Stainless Steel / Polyamide

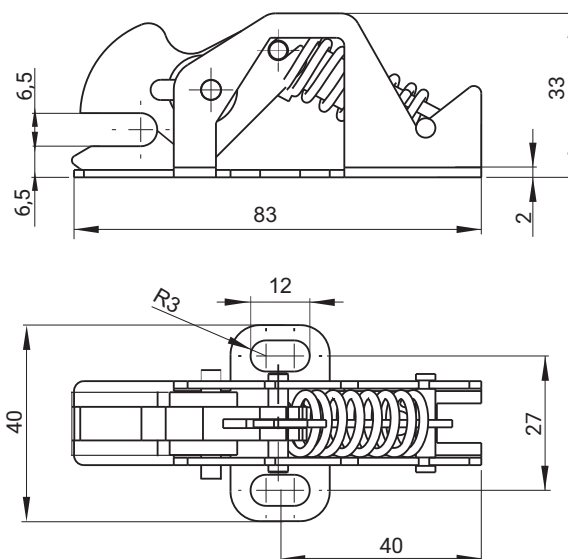

TYPE OF LOCK	COMPONENTS	MATERIAL
2.502.001	Housing / Cam	Steel zinc plated / Polyamide
2.502.001SN	Housing / Cam	Stainless Steel / Polyamide

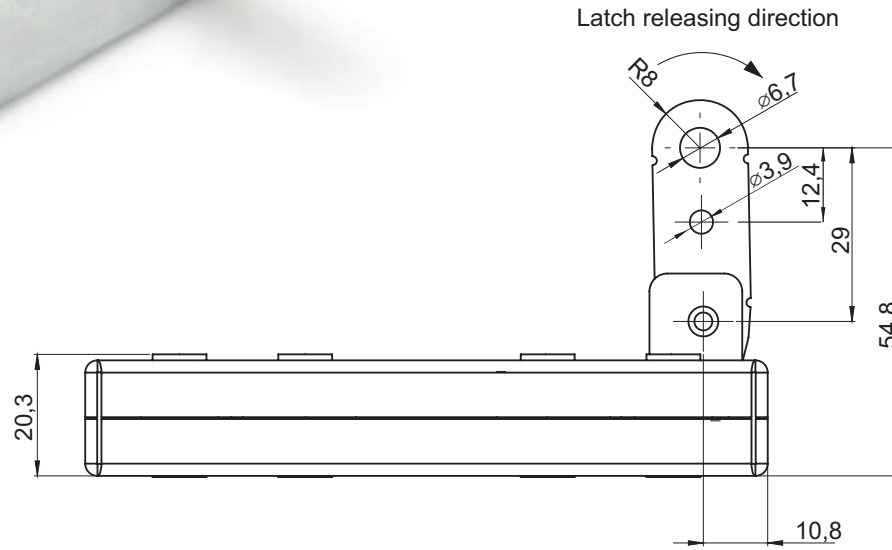

Max diameter of latching rod is 17mm

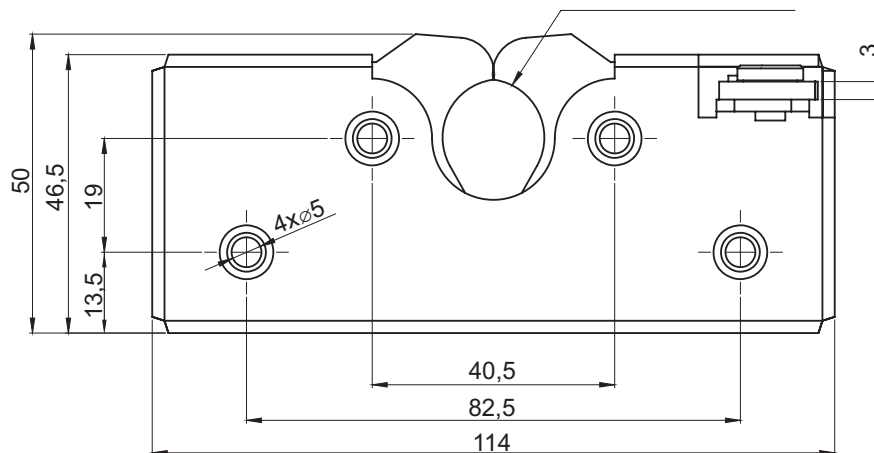

TYPE OF LOCK	COMPONENTS	MATERIAL
2.507.001	Housing	Zinc plated steel
	Bolt	Oxidized steel

stainless steel

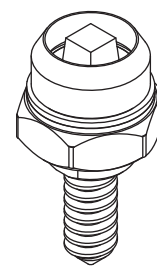
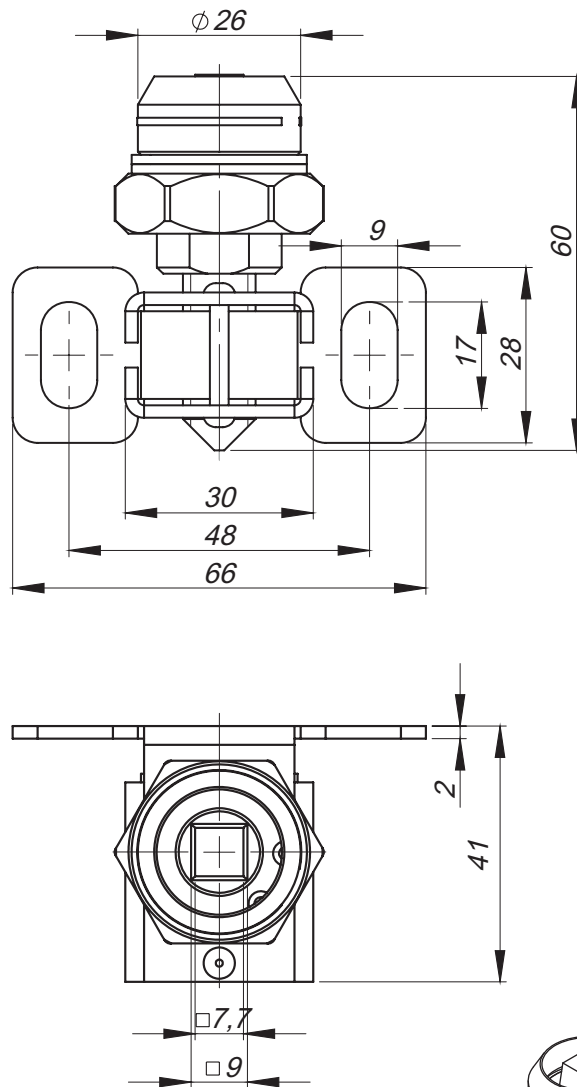

Locking flap

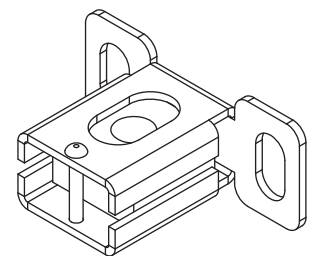

Locking flap handle

TYPE OF LOCK	COMPONENTS	MATERIAL
2.700.001	Locking flap	Stainless steel AISI 316L
	Locking flap handle	Stainless steel AISI 304

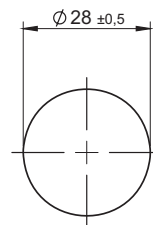
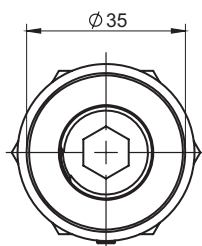
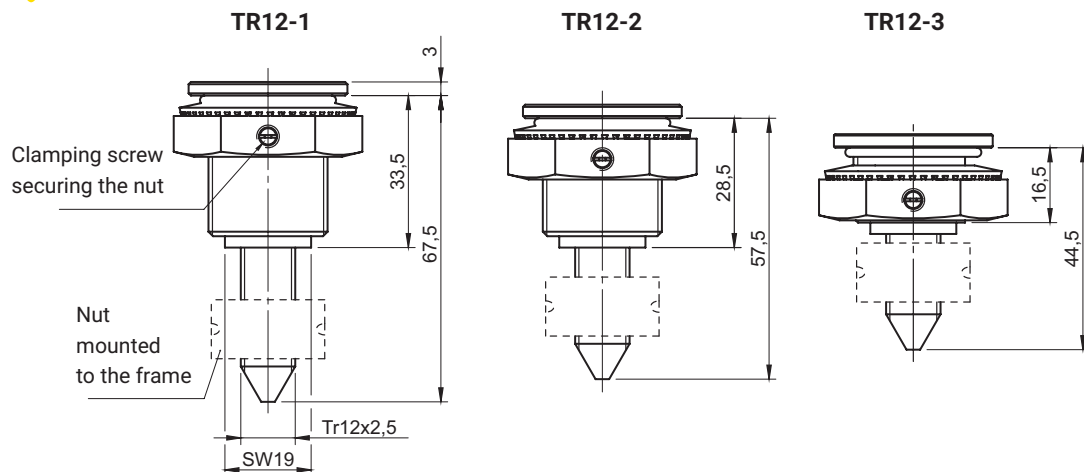

Cut out

Nut TR12x2,5

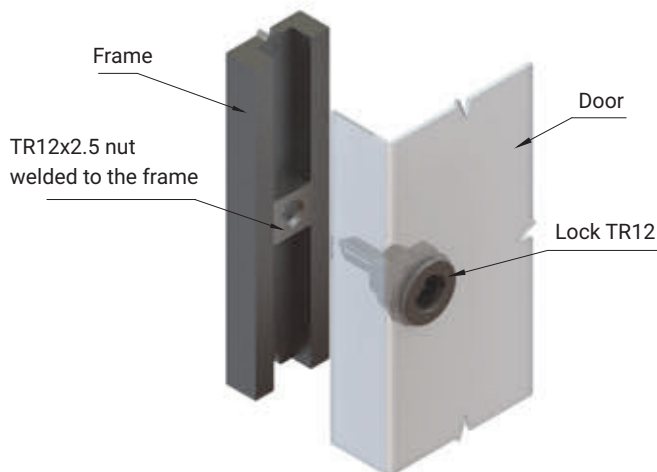
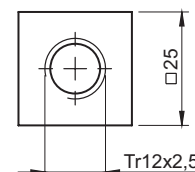

CATALOGUE NUMBER	INSERTS [D]	COMPONENTS	MATERIAL
TR12-1 TR12-2 TR12-3		Housing, Insert	Stainless steel
TR12x2,5	-	Nut	Stainless steel

How to order:

Catalogue number
Type of insert

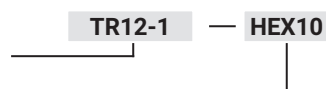

Nut TR12x2,5 to be ordered separately



Cover 2.904.005

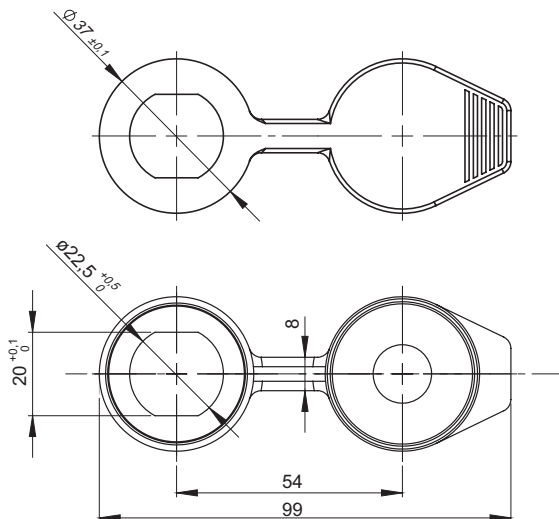

Cover 2.904.006

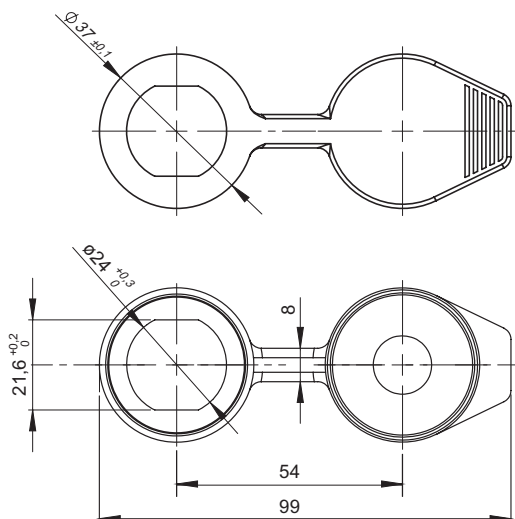

Cover 2.904.007

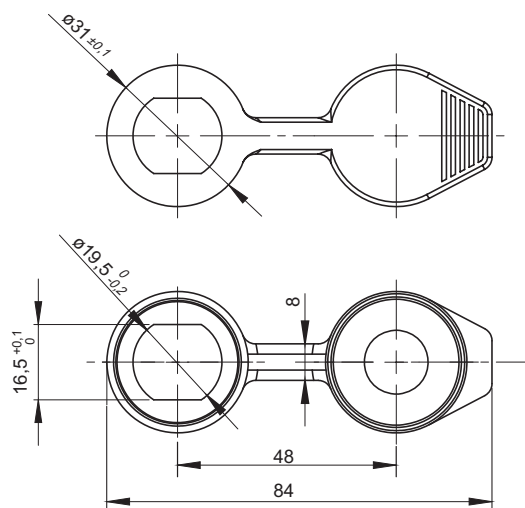

Cover 2.904.008

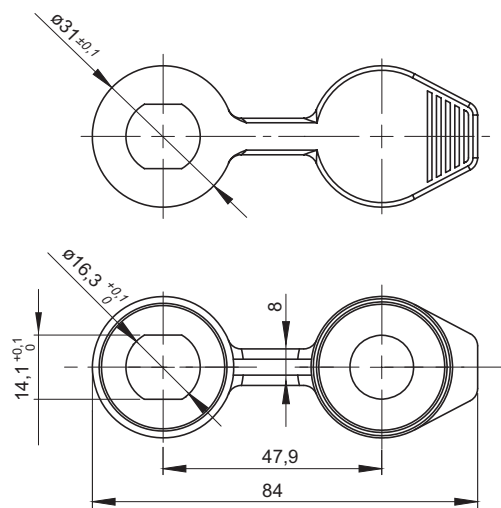

Attention:
In case of adjusting the handle the H dimension reduces of 2mm

CATALOGUE NUMBER	TYPE OF LOCK	MATERIAL	FINISH [C]
2.904.005	M22	TPE	RAL9005
2.904.006	M24		07
2.904.007	M19W		
2.904.008	M16		

* colour 7035 available on special request

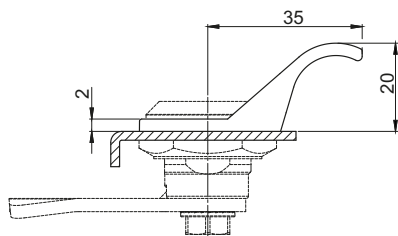

2.905.004A

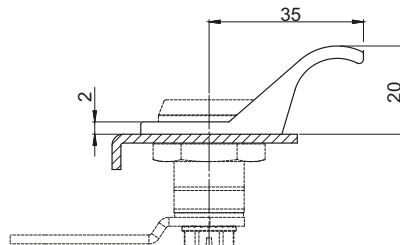

2.905.003A

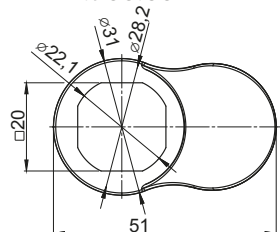

2.905.004B

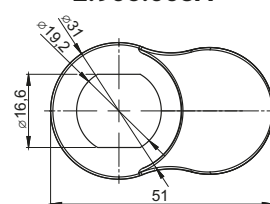

2.905.003B

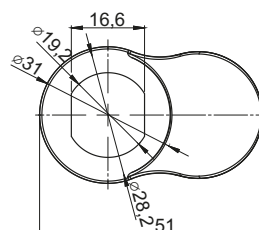
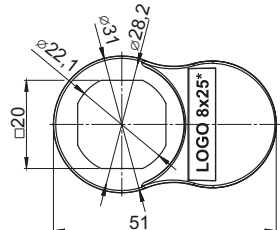

CATALOGUE NO.	DETAIL	MATERIAL	FINISH [C]	
			RAL 9005	RAL 7035
2.905.004A	Handle for lock M22	Polyamide PA6 GF30	07	08
2.905.004B				
2.905.003A	Handle for lock M19	Polyamide PA6 GF30	07	08
2.905.003B				

How to order :

Catalogue no.

Finish

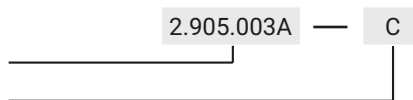

* Optional logo on the handle 2.905.004B with dimension 8x25 mm.

Handle for lock 2.905.004 is fitted with all locks M22 with the outside diameter of flanged housing $\varnothing 28$.

2.905.003 and 2.905.013 are fitted with locks M19W, M19DC, Z-2106, 2.612.001.

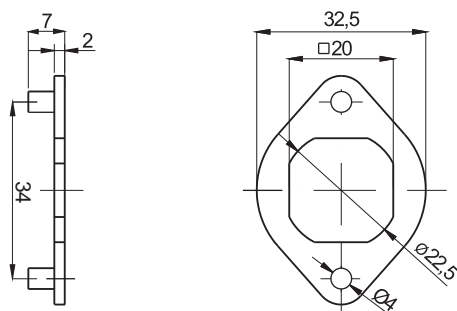

CATALOGUE NUMBER	COMPONENTS	MATERIAL
2.907.002	Locking washer	Steel zinc plated
2.907.002SN	Locking washer	Stainless steel

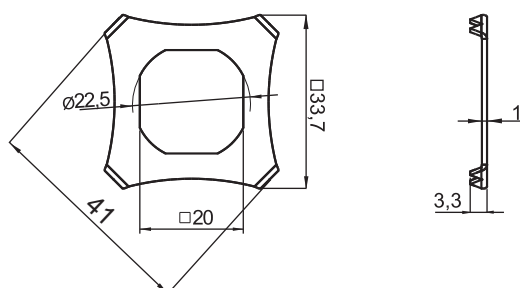

CATALOGUE NUMBER	COMPONENTS	MATERIAL
2.911.001	Locking washer	Steel zinc plated
2.911.001SN	Locking washer	Stainless steel



Blockade ST2

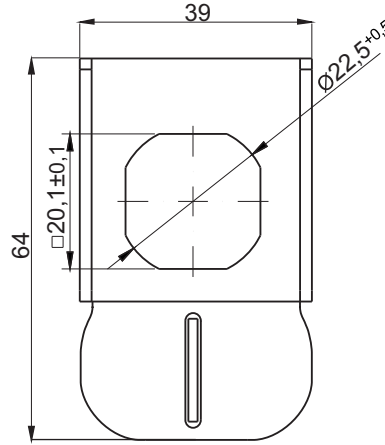
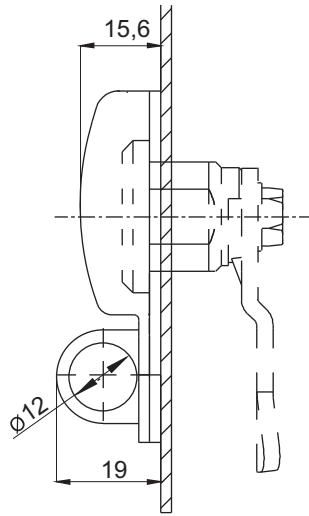

Blockade 2.902.001

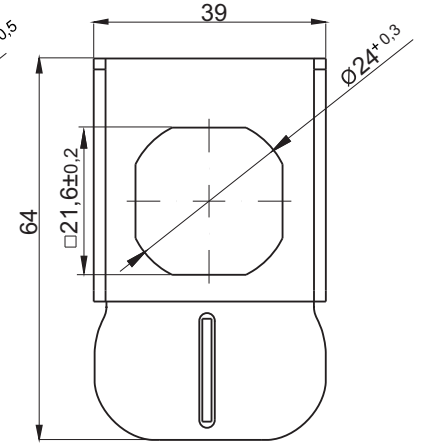

Blockade 2.902.002

CATALOGUE NUMBER	TYPE OF LOCK	COMPONENTS	MATERIAL
2.902.001	M22	Rate, flape	Steel zinc plated
2.902.001SN	M22	Rate, flape	Stainless steel
2.902.002	M24	Rate, flape	Steel zinc plated
2.902.002SN	M24	Rate, flape	Stainless steel



Blockade ST2.02

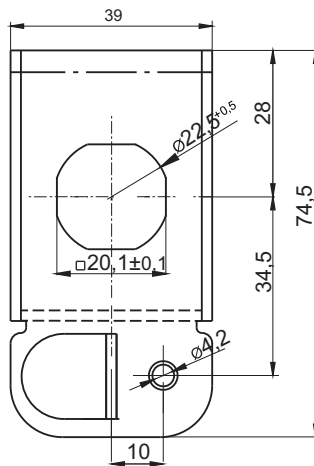
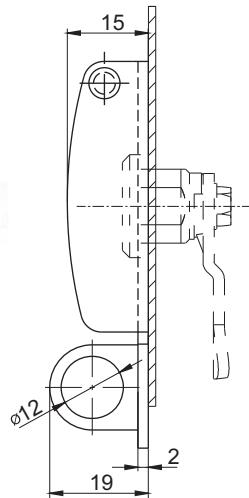

Blockade 2.904.101

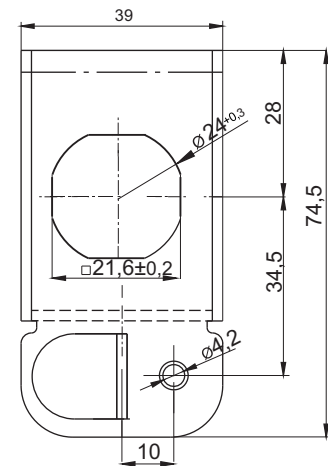

Blockade 2.905.102

CATALOGUE NUMBER	TYPE OF LOCK	COMPONENTS	MATERIAL
2.904.101	M22	Rate, flape	Steel zinc plated
2.904.101SN	M22	Rate, flape	Stainless steel
2.905.102	M24	Rate, flape	Steel zinc plated
2.905.102SN	M24	Rate, flape	Stainless steel

Blockade ST1

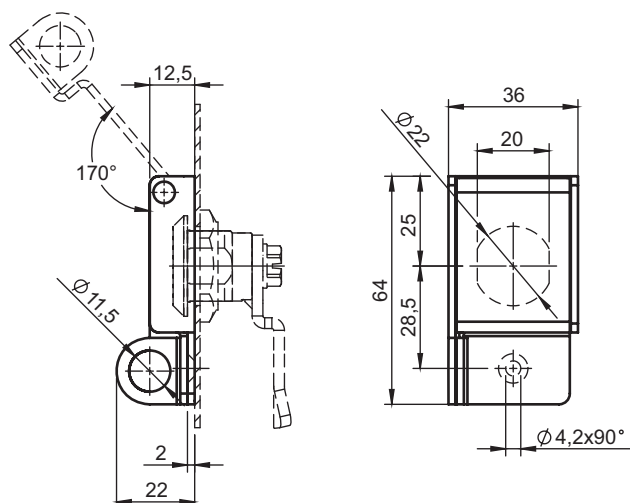

CATALOGUE NUMBER	COMPONENTS	MATERIAL
2.901.001	Rate, flap	Steel zinc plated
2.901.001SN	Rate, flap	Stainless steel

Blockade ST1

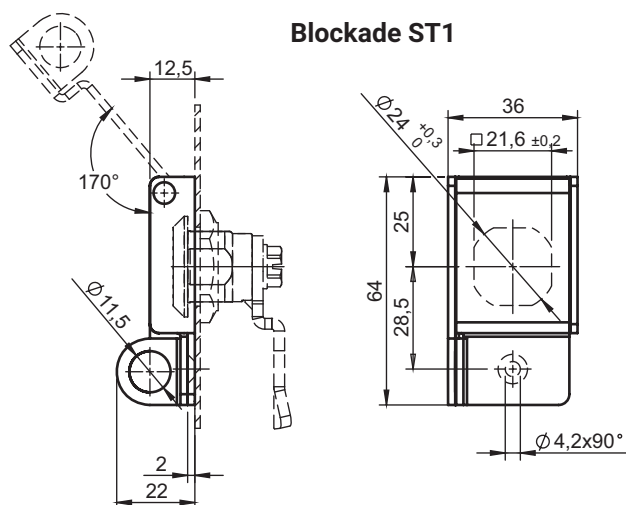

CATALOGUE NUMBER	COMPONENTS	MATERIAL
2.901.002	Rate, flap	Steel zinc plated
2.901.002SN	Rate, flap	Stainless steel

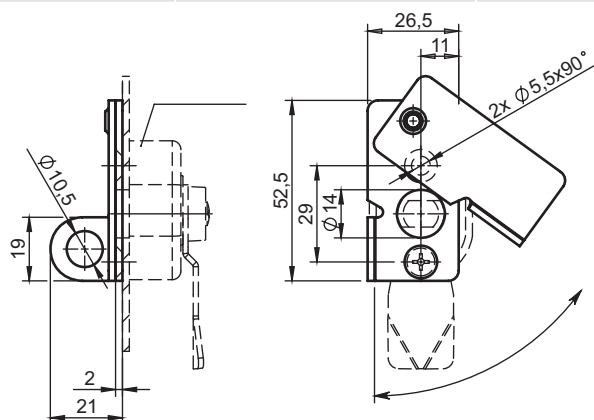

CATALOGUE NUMBER	COMPONENTS	MATERIAL
2.903.001	Rate, flap	Steel zinc plated
2.903.001SN	Rate, flap	Stainless steel
2.903.001AL	Rate, flap	Aluminum

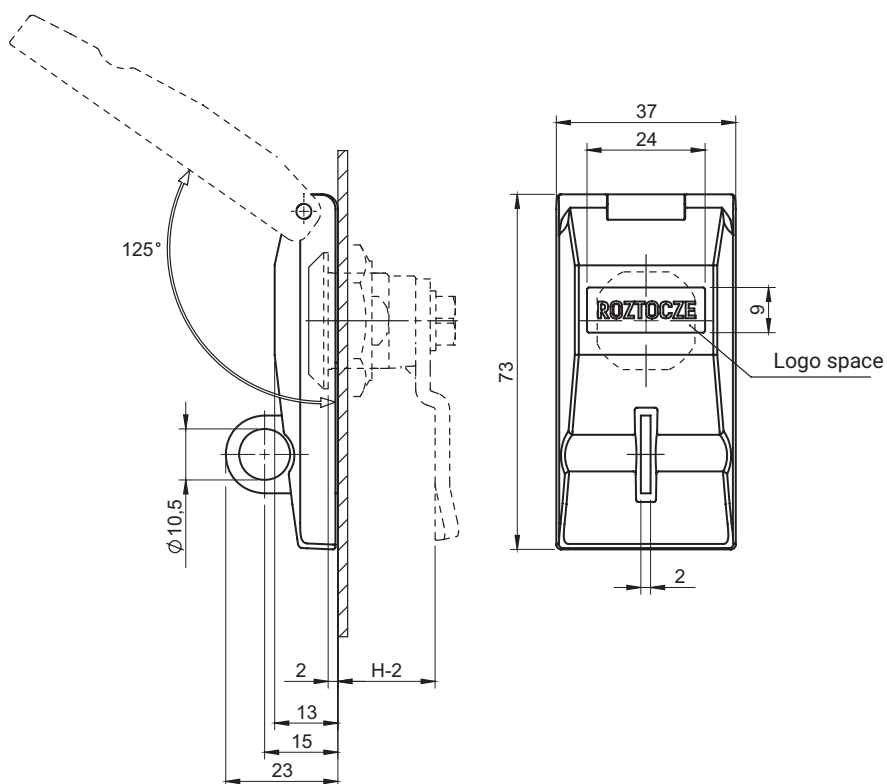

* Customized logo available.

CATALOGUE NUMBER	TYPE OF LOCK	COMPONENTS	MATERIAL
2.910.001	M22	Base Lock cover	Steel zinc plated ZAMAK
2.910.002	M24		
FINISH [C]			
Nickel		RAL9005	
02		04	

How to order:

Catalogue number
Finish



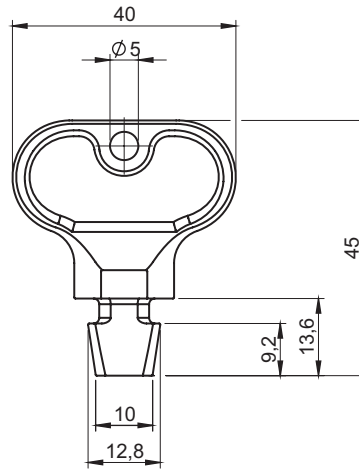

CATALOGUE NUMBER	MATERIAL	FINISH [C]	
		RAL 9005	RAL 7035
2.KLE-GZ.001	Polyamide	07	08

How to order:

Catalogue number, type of key
Finish

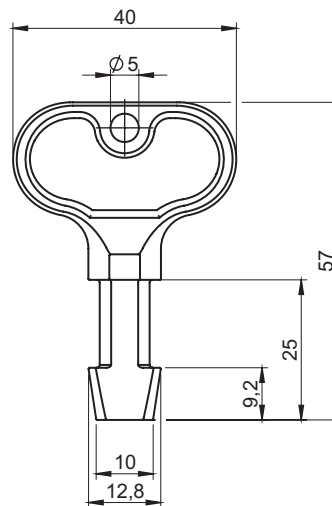
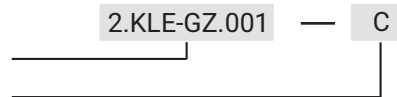

CATALOGUE NUMBER	MATERIAL	FINISH [C]	
		RAL 9005	RAL 7035
2.KLF-GZ.001	Polyamide	07	08

How to order:

Catalogue number, type of key
Finish

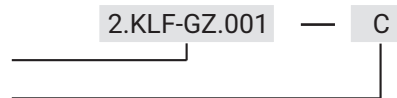

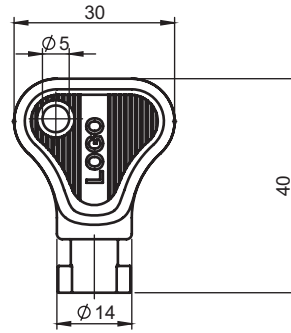

Customized logo on the key available.

CATALOGUE NUMBER	MATERIAL	TYPE OF KEY [X]			FINISH [C]	
		D5	T9	KW 8	07	08
2.KLB-X.001	Polyamide				RAL 9005	RAL 7035

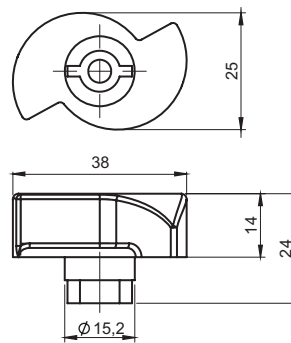

CATALOGUE NUMBER	MATERIAL	TYPE OF KEY [X]				FINISH [C]	
		D5	T9	KW 8	C9	07	08
2.KLA-X.001	Polyamide					RAL 9005	RAL 7035

How to order:

Catalogue number, type o key [X]

Finish

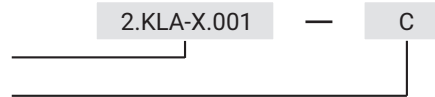

Wing knob for T13 insert

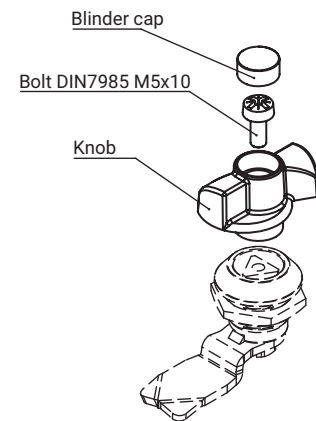
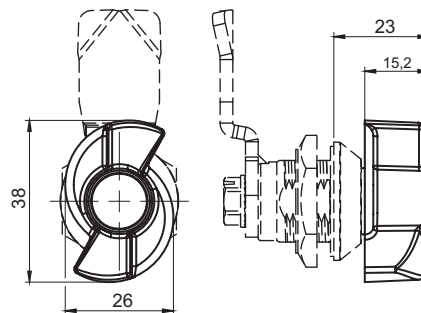

Wing knob for T13 pin, M22-2 and M22-DU locks (pages 2A-9 and 2A-11)

CATALOGUE NUMBER	COMPONENTS	MATERIAL	Finish [C]
			RAL 9005
2.KLD-T13.001	T-handle, Blinder cap	Polyamide	07
	Bolt M5x10	Steel zinc plated	-

How to order:

Catalogue no.

Finish

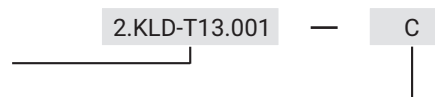

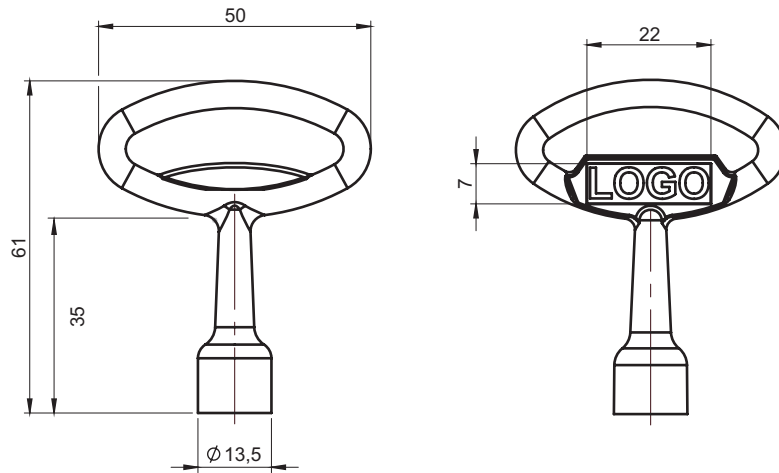

Possibility of making logo key on request.

CATALOGUE NUMBER											MATERIAL			
2.KL-X.001											ZAMAK5			
Type of key [X]											Finish [C]			
											No finish	Chrome	Nickel	RAL 9005
D3	D5	T6	T7	T9	KW6	KW7	KW8	N	C9	Q	00	01	02	04

How to order:

Catalogue number, type o key [X]

Finish

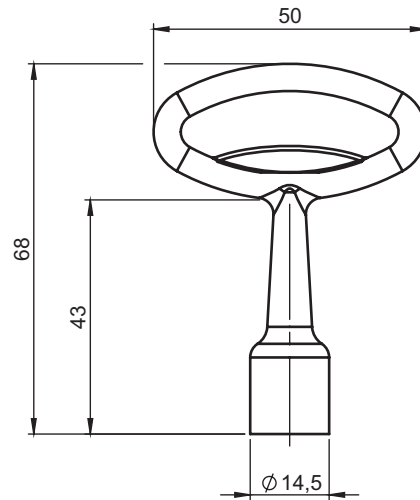
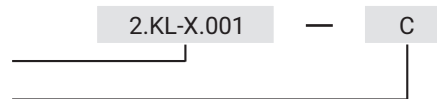

CATALOGUE NUMBER								MATERIAL			
2.KL-X.002								ZAMAK5			
Type of key [X]								Finish [C]			
								No finish	Chrome	Nickel	RAL 9005
T9	T10	KW6	KW7	KW8	KW8 zew	C9	D9	00	01	02	04

How to order:

Catalogue number, type o key [X]

Finish

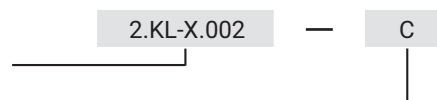

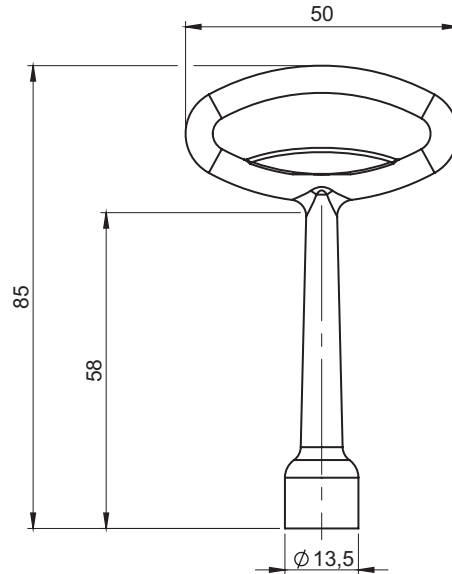

CATALOGUE NUMBER				MATERIAL			
2.KL-X.003				ZAMAK5			
Type of key [X]				Finish [C]			
				No finish	Chrome	Nickel	RAL 9005
D3	D5	T9	KW8	00	01	02	04

How to order:

Catalogue number, type o key [X]

Finish

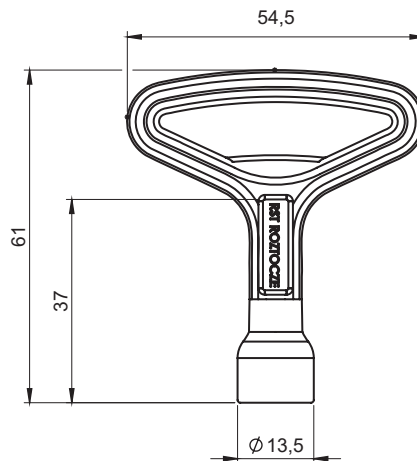
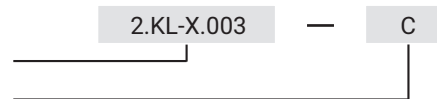

Possibility of making logo key on request.

CATALOGUE NUMBER			MATERIAL			
2.KL-X.004			ZAMAK5			
Type of key [X]			Finish [C]			
			No finish	Chrome	Nickel	RAL 9005
D5	T9	KW8	00	01	02	04

How to order:

Catalogue number, type o key [X]

Finish

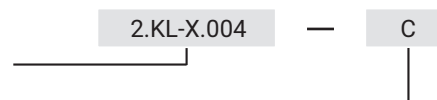

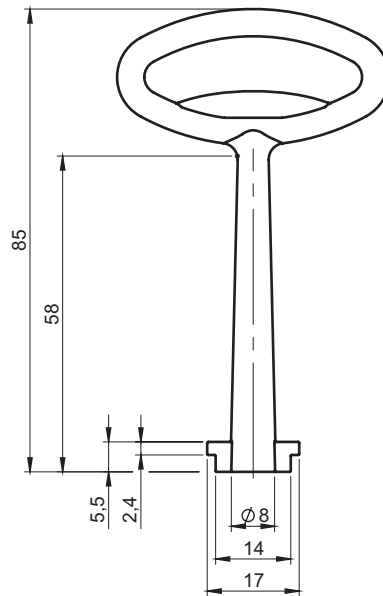

CATALOGUE NUMBER		MATERIAL			
2.KL-X.005		ZAMAK5			
Type of key [X]		Finish [C]			
		No finish	Chrome	Nickel	RAL 9005
D3S	D5S	00	01	02	04

How to order:

Catalogue number, type o key [X]

Finish

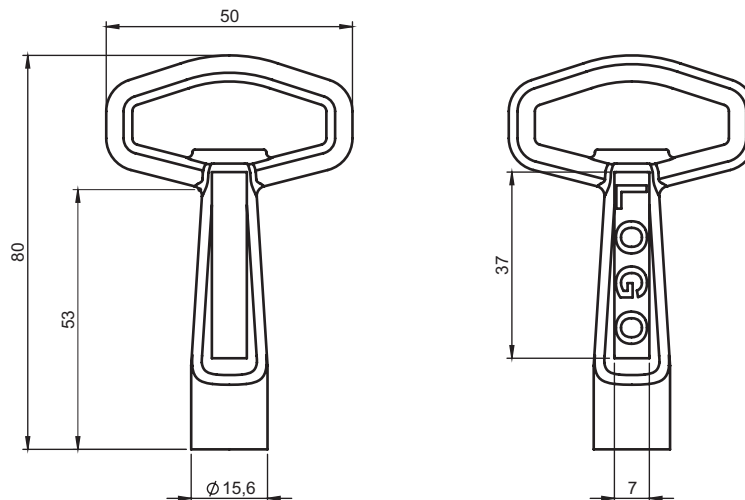
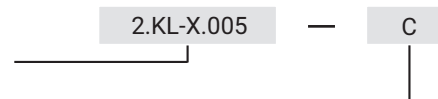

Possibility of making logo key on request.

CATALOGUE NUMBER							MATERIAL			
2.KL-X.006							ZAMAK5			
Type of key [X]							Finish [C]			
							No finish	Chrome	Nickel	RAL 9005
KW8	T9	T10	T11	T12	T13	HEX9	00	01	02	04

How to order:

Catalogue number, type o key [X]

Finish

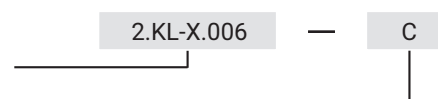

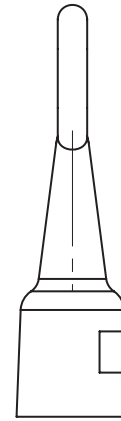
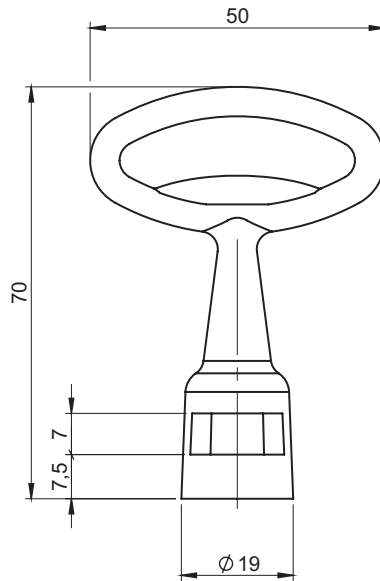

CATALOGUE NUMBER	MATERIAL	Type of key [X]	Finish [C]			
			No finish	Chrome	Nickel	RAL 9005
2.KL-X.007	ZAMAK5		00	01	02	04
		D13S				

How to order:

Catalogue number, type o key [X]

Finish

2.KL-D13S.007

C

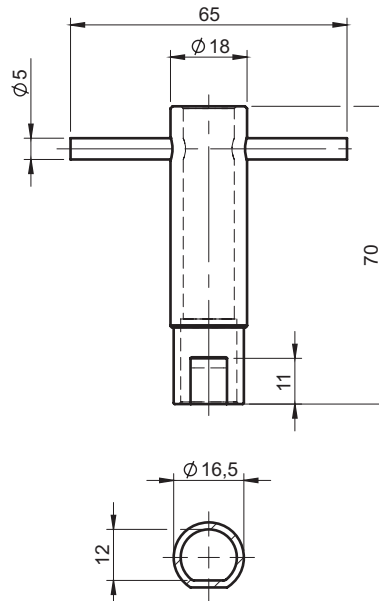

CATALOGUE NUMBER	MATERIAL
2.KL-D13S.008	Steel zinc plated

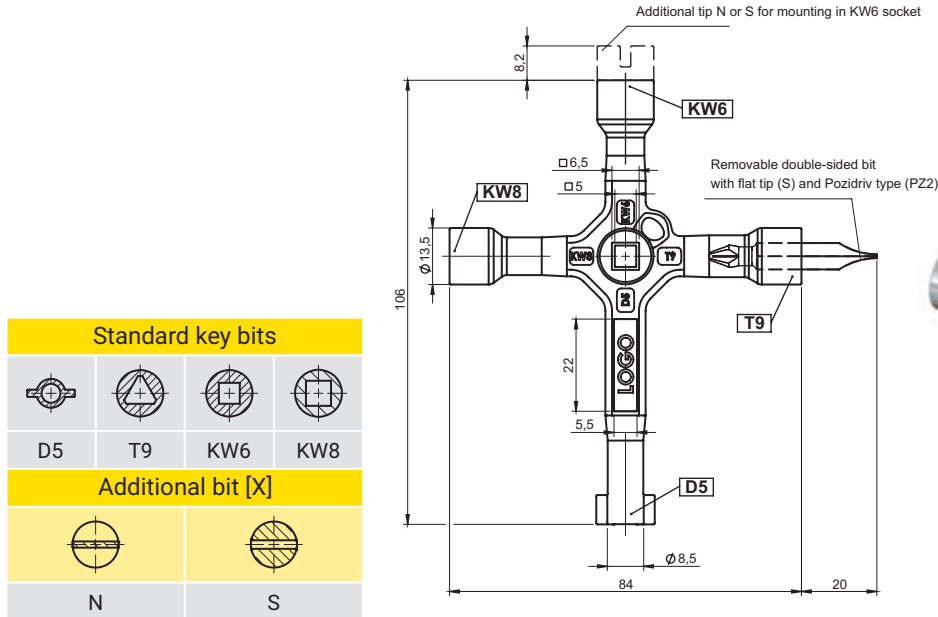

Removable double-sided bit with flat tip (S) and Pozidriv type (PZ2)
Key supplied with double bit, additional N or S bits ordered separately.

CATALOGUE NUMBER	COMPONENTS	MATERIAL	Finish [C]			
			No finish	Chrome	Nickel	RAL 9005
2.KL.009	Key, additional bits	ZAMAK5				
	Bit S / PZ2	Tool steel	00	01	02	04

How to order :

Catalogue number

Additional bit

When ordering more than one, enter the symbols after the comma.
When ordering a key without an additional bit, omit the following

Finish [C]

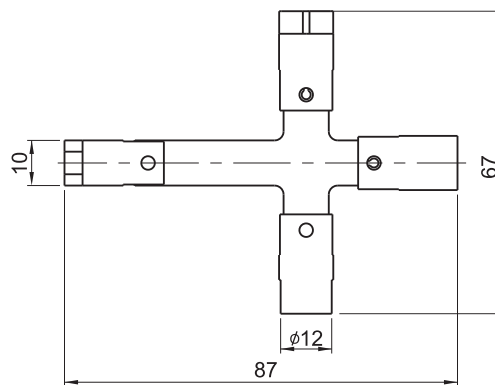
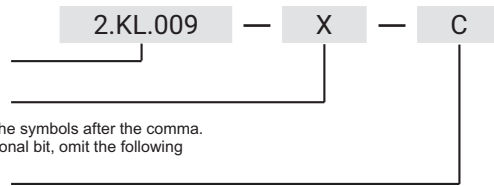

Type of key [X]												
CATALOGUE NUMBER												
COMPONENTS												
MATERIAL												
2.KLT-WF.001	Tip						Steel zinc plated					
	Phillips						Stainless steel					

How to order :

Catalogue number

Type of key

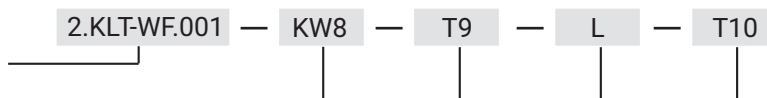



LOCK ZG

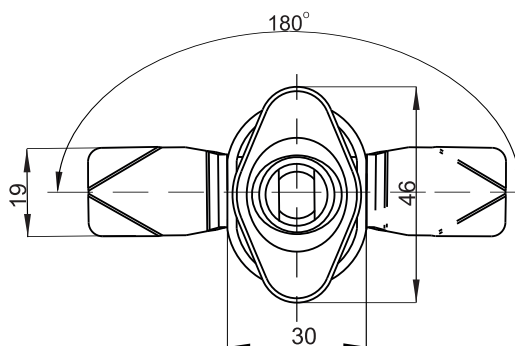
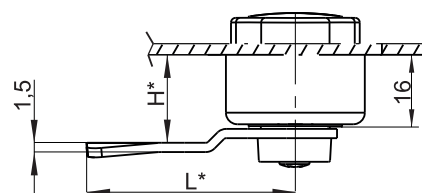

LOCK ZG AX

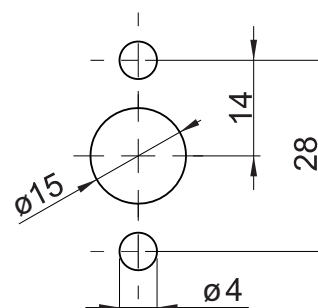

Cut Out

Table no. 1

CAM CODE	H*	L*	INSERT [X]	
001	16	30		
002	16	45		
003	19	30		
004	19	45	GZ	N

TYPE OF LOCK	COMPONENTS	MATERIAL	FINISH [C]	
			RAL 9005	RAL 7035
	Housing, insert	Polyamide	07	08
	Blokade	Steel zinc plated	-	-
		Stainless steel	-	-

How to order :

Type of lock

Type of insert [X]

Cam code

Finish [C]



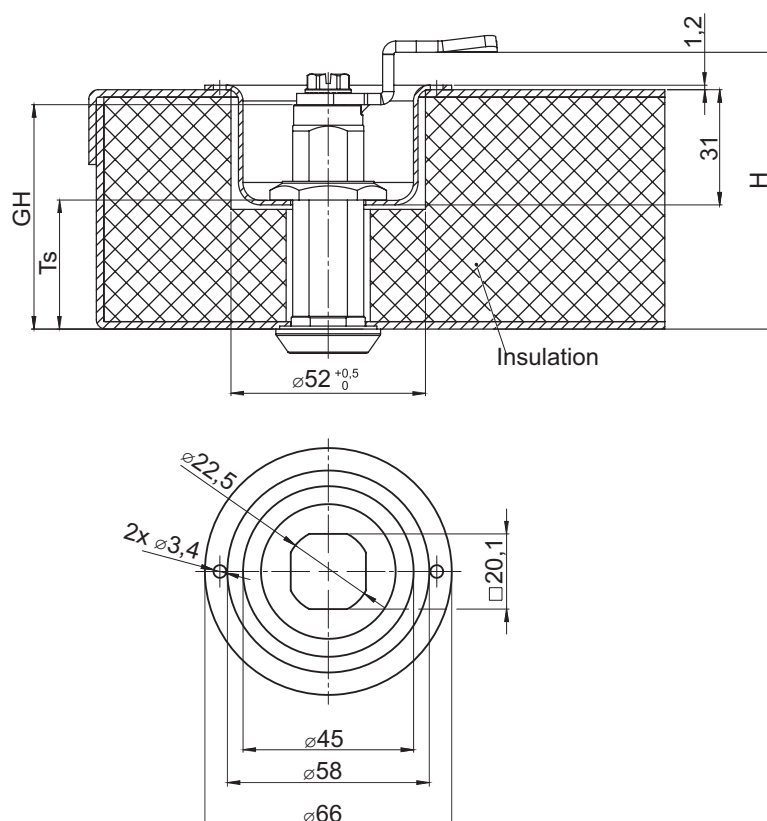
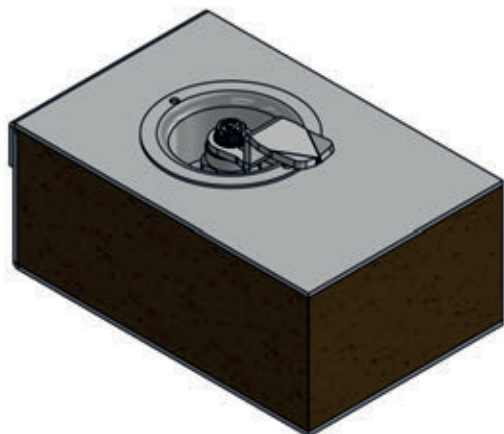

Fitted with locks M22 reducing the thickness of insulated doors
 Fitted with locks M22, M22-30, M22-60.
Ts - the thickness of the door.

CATALOGUE NO.	DETAIL	MATERIAL
2.920.001	Adapter	Zinc plated steel





1

Locking systems

2

Locks
Latches



3

Hinges



4

Clamps



5

Accessories



6

Gasketing profiles



7

Custom products

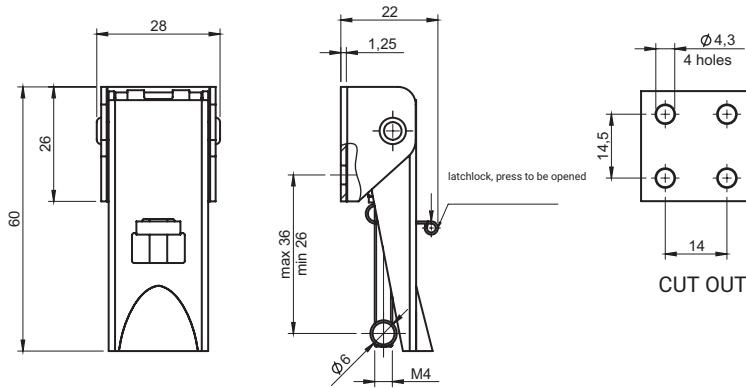

Preferred catch:
 - 3.ST200.001 (2B-1)
 - 3.ST200.001SN (2B-1)
 - 3.ST201UN.001 (2B-1)
 - 3.ST201UN.001SN (2B-1)
 Catch ordered separately

CATALOGUE NUMBER	MATERIAL
3.ST201.001	Steel zinc plated
3.ST201.001SN	Stainless steel

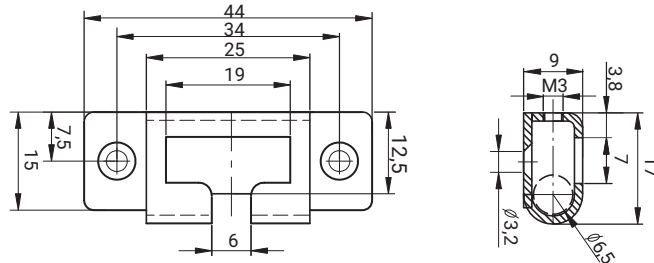

CATALOGUE NUMBER	MATERIAL
3.ST201UN.001	Steel zinc plated
3.ST201UN.001SN*	Stainless steel



3.ST200.002

3.ST202.001

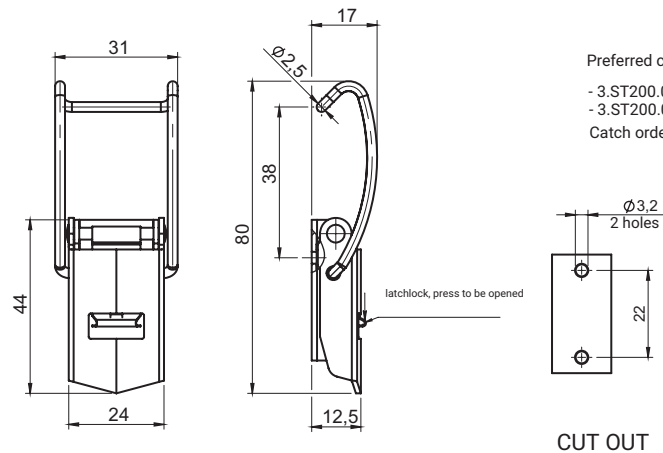

Preferred catch:
 - 3.ST200.002 (2B-1)
 - 3.ST200.002SN (2B-1)
 Catch ordered separately

CATALOGUE NUMBER	MATERIAL
3.ST202.001	Steel zinc plated
3.ST202.001SN	Stainless steel

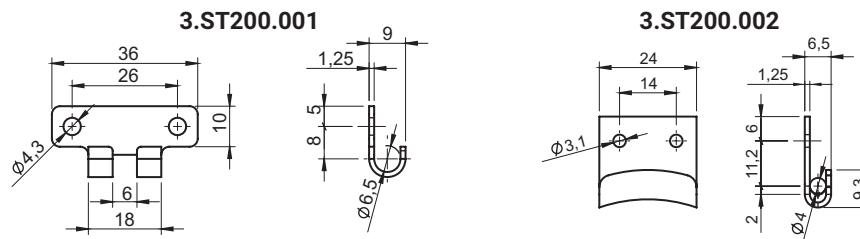

CATALOGUE NUMBER	MATERIAL
3.ST200.001	Steel zinc plated
3.ST200.001SN	Stainless steel
3.ST200.002*	Steel zinc plated
3.ST200.002SN*	Stainless steel

* detail to be ordered separately

Latch 3.ST204, 3.ST205 Catch 3.ST200

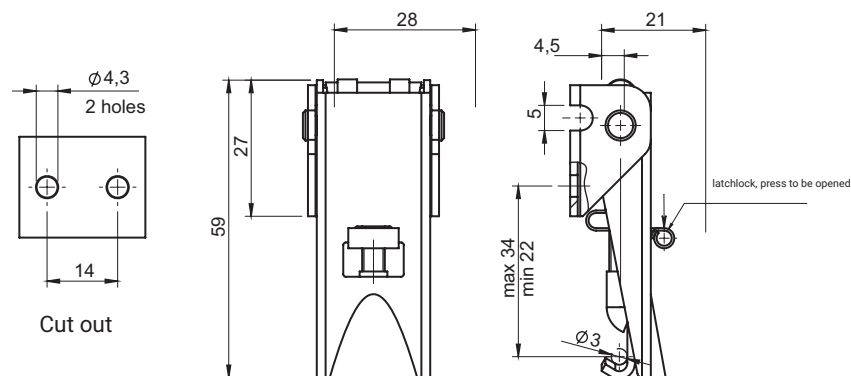

Preferred catch:
 - 3.ST200.003 (2B-2)
 - 3.ST200.003SN (2B-2)
 Catch ordered separately

CATALOGUE NUMBER	MATERIAL
3.ST204.001	Steel zinc plated
3.ST204.001SN	Stainless steel

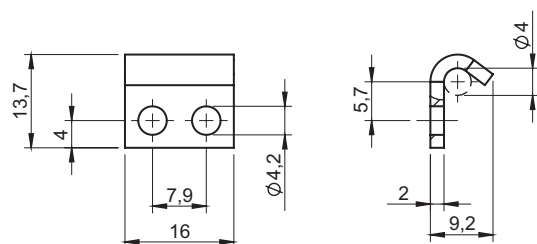

Catch can be used with:
 3.ST204.001
 3.ST204.001SN
 3.ST205.001
 3.ST205.001SN

CATALOGUE NUMBER	MATERIAL
3.ST200.003*	Steel zinc plated
3.ST200.003SN*	Stainless steel

* detail to be ordered separately

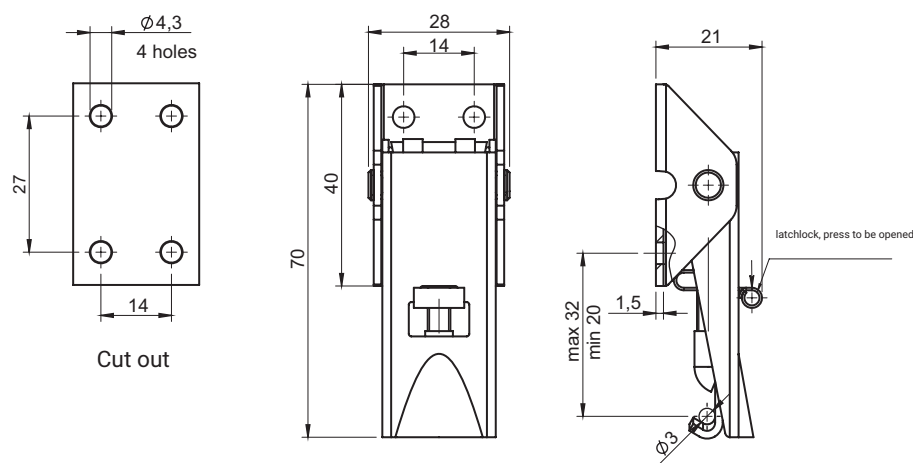

Preferred catch:
 - 3.ST200.003 (2B-2)
 - 3.ST200.003SN (2B-2)
 Catch ordered separately

CATALOGUE NUMBER	MATERIAL
3.ST205.001	Steel zinc plated
3.ST205.001SN	Stainless steel

stainless steel

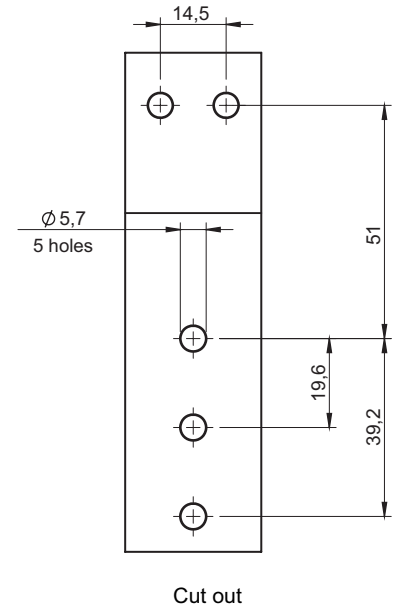
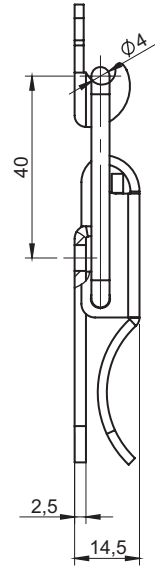
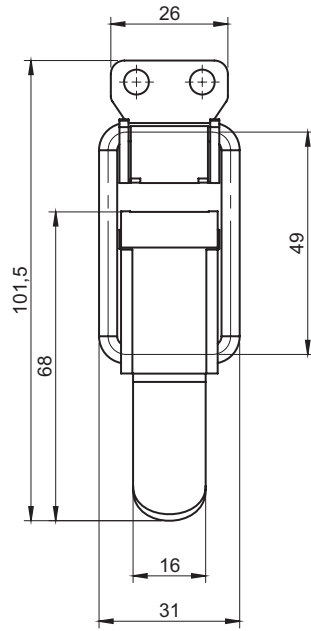

Latch supplied with a catch

CATALOGUE NO.	MATERIAL
3.ST264.001	Stainless steel

stainless steel

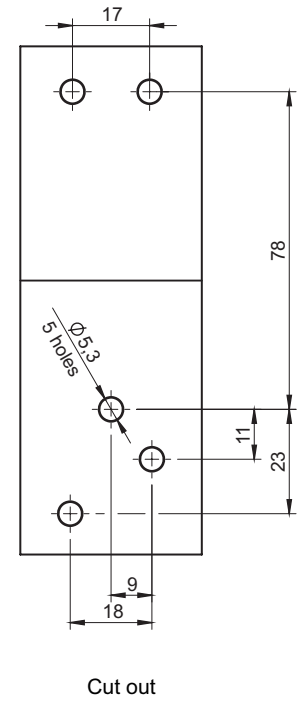
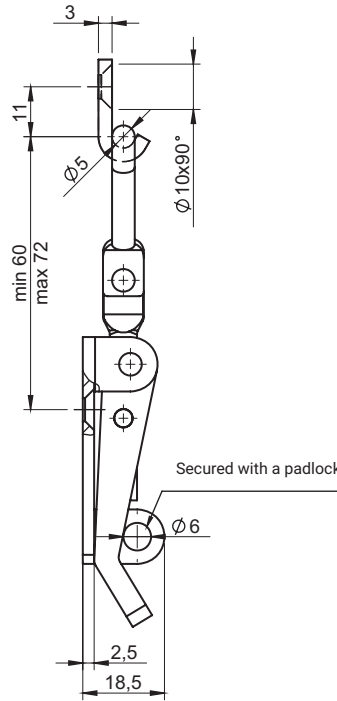
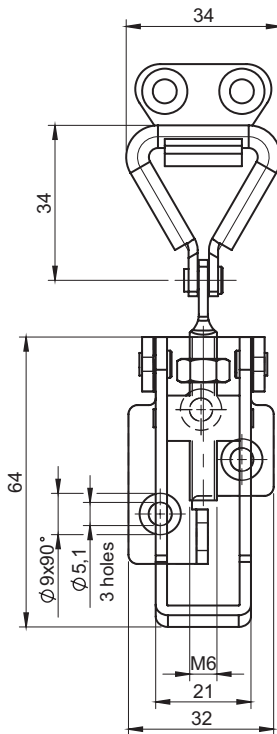

CATALOGUE NO.	DETAIL	MATERIAL
3.ST265.001SN	Latch secured with a padlock	Stainless steel

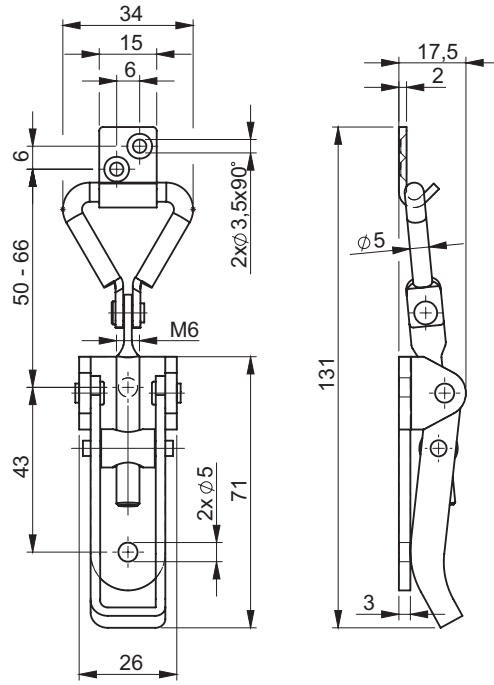

stainless steel



CATALOGUE NUMBER	MATERIAL
3.ST265.002	Steel zinc plated
3.ST265.002SN	Stainless steel

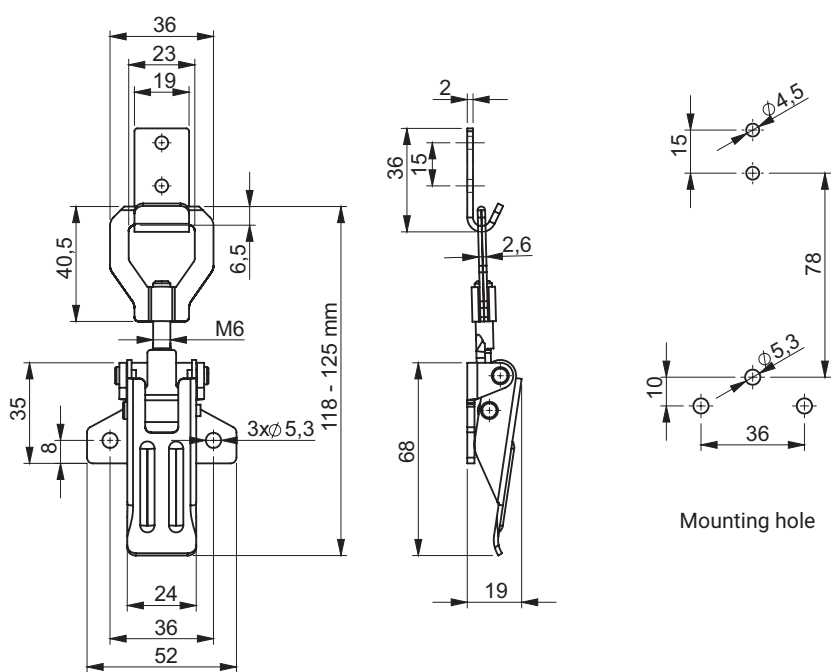

stainless steel



CATALOGUE NUMBER	MATERIAL
3.ST265.003	Steel zinc plated
3.ST265.003SN	Stainless steel

stainless steel

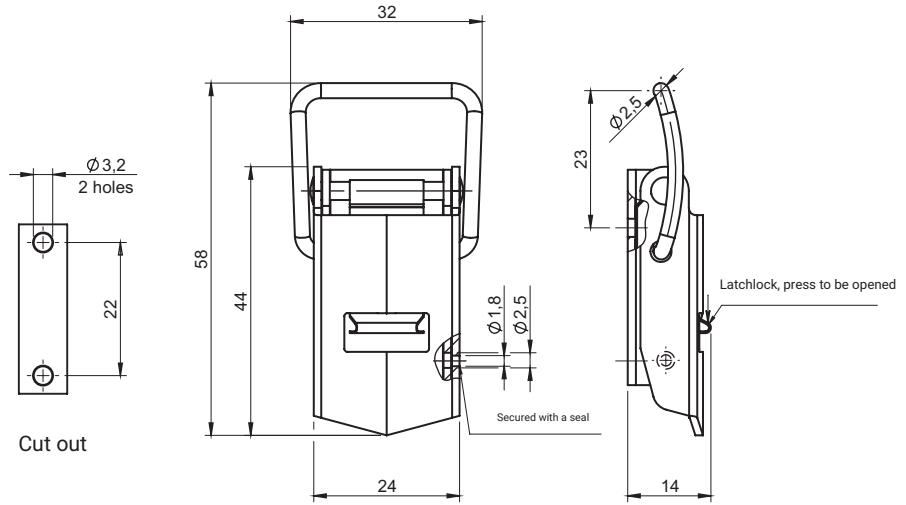

Preferred catch:

- 3.ST200.002 (2B-1)
- 3.ST200.002SN (2B-1)

Catch ordered separately

CATALOGUE NUMBER	MATERIAL
3.ST206.001*	Steel zinc plated
3.ST206.001SN*	Stainless steel

stainless steel

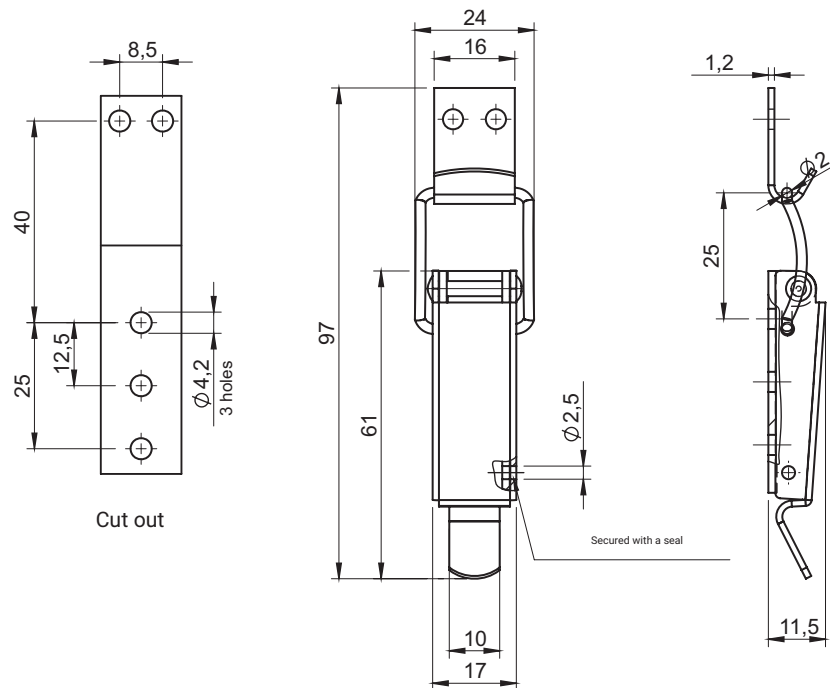

Latch supplied with a catch

CATALOGUE NUMBER	MATERIAL
3.ST207.001	Steel zinc plated
3.ST207.001SN	Stainless steel

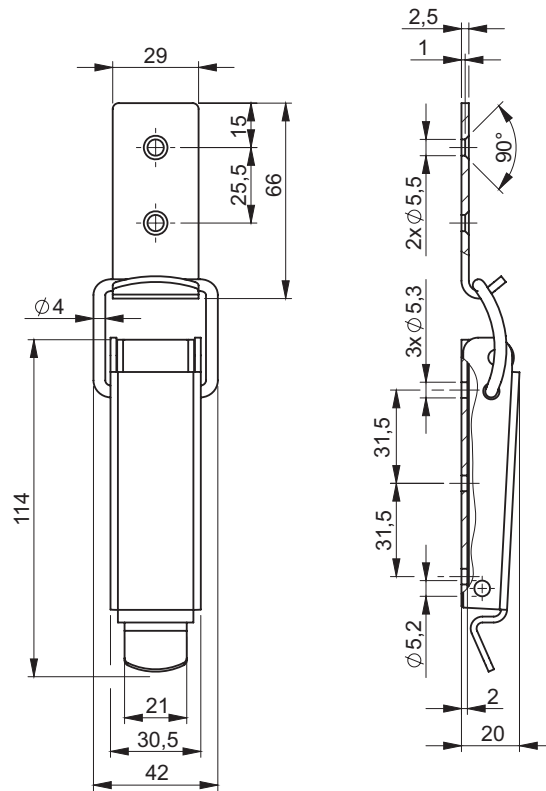

CATALOGUE NUMBER	MATERIAL
3.ST209.001	Steel zinc plated
3.ST209.001SN	Stainless steel

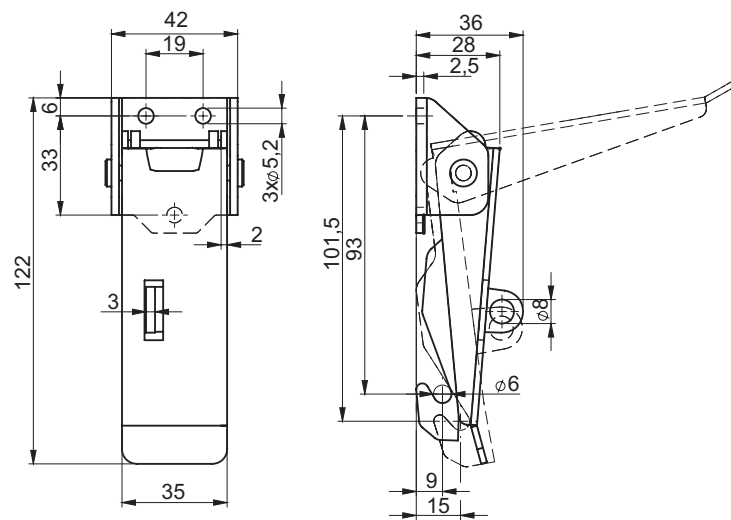

CATALOGUE NUMBER	MATERIAL
3.ST211.001	Steel zinc plated
3.ST211.001SN	Stainless steel

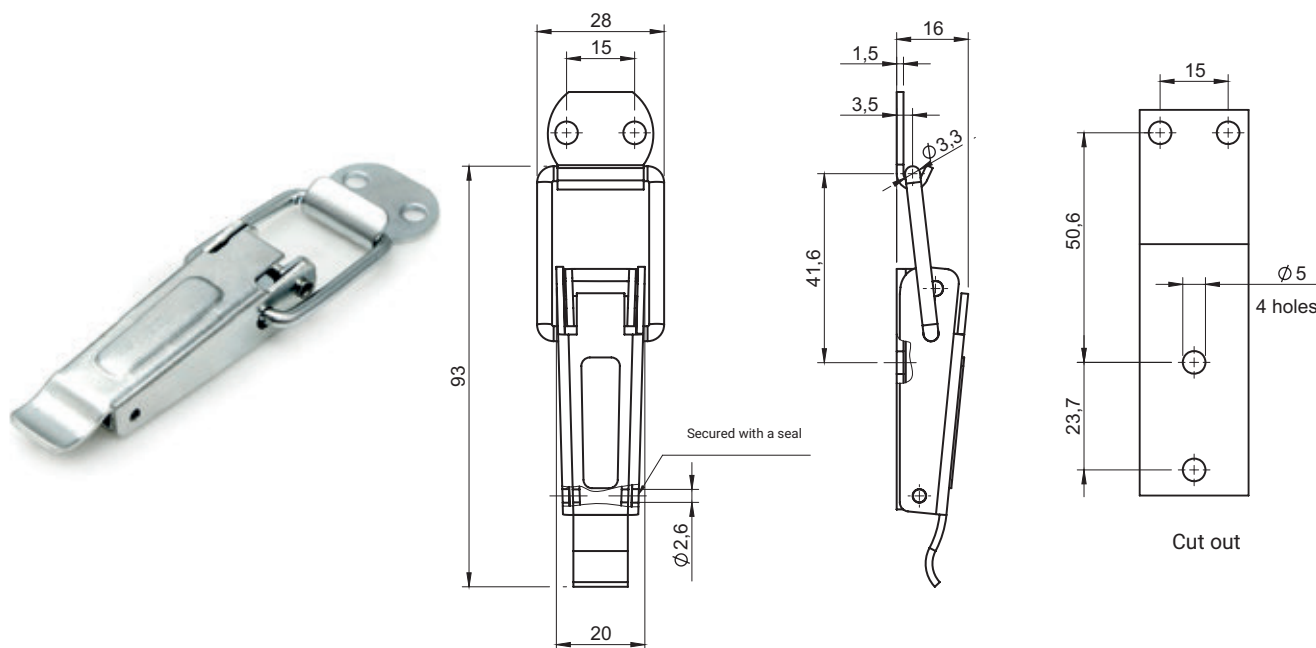

Latch supplied with a catch

CATALOGUE NUMBER	MATERIAL
3.ST261.001	Steel zinc plated

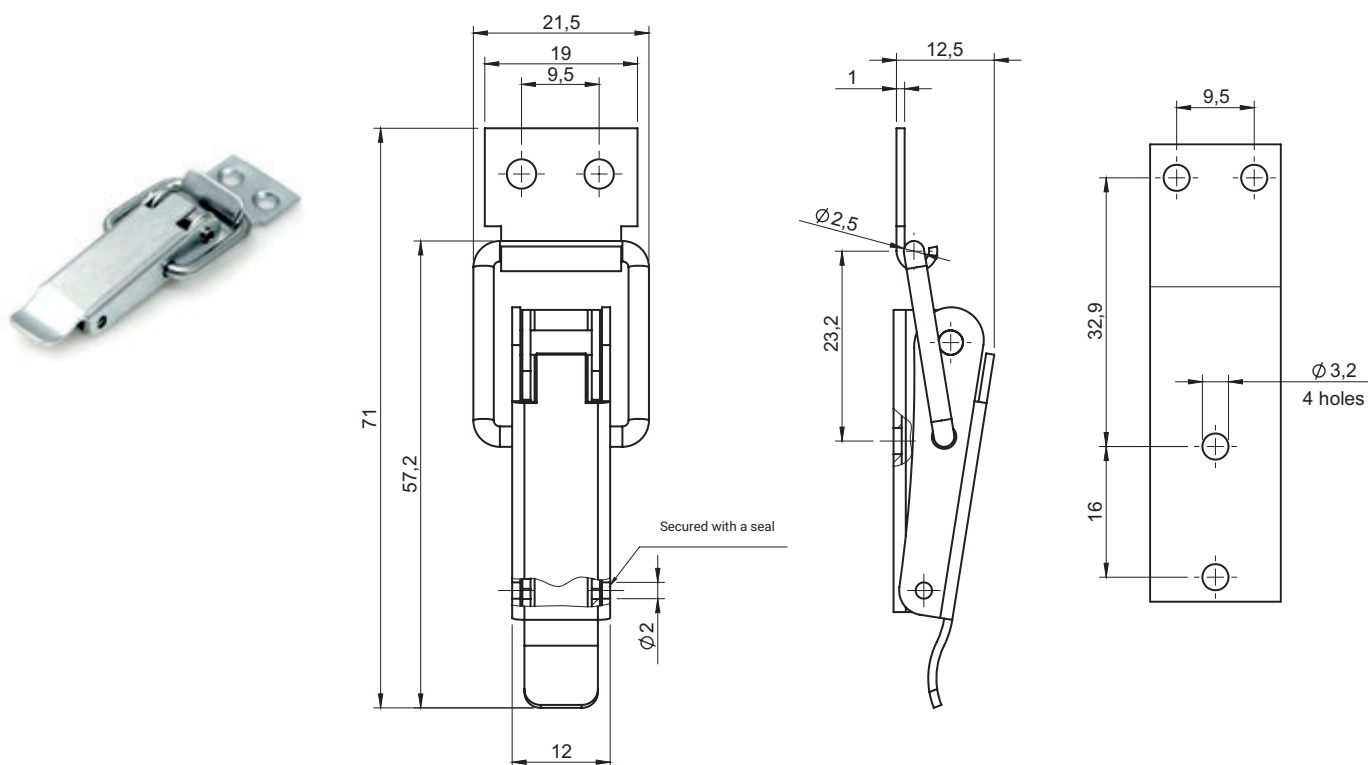

Latch supplied with a catch

CATALOGUE NUMBER	MATERIAL
3.ST262.001	Steel zinc plated

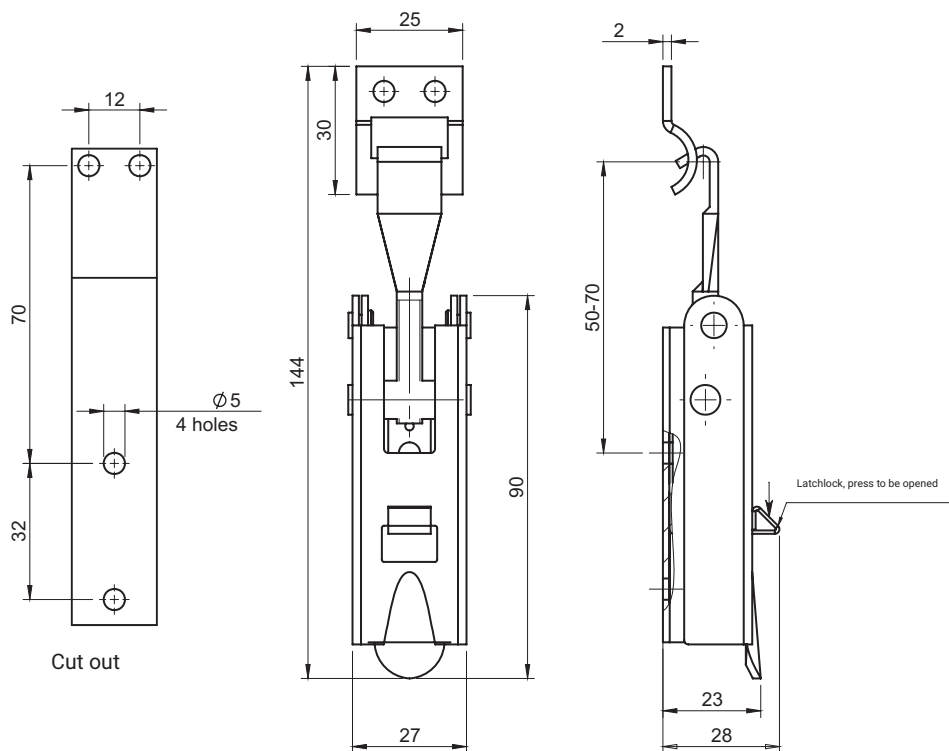

stainless steel

Latch supplied with a catch

CATALOGUE NUMBER	MATERIAL
3.ST208.001	Steel zinc plated
3.ST208.001SN	Stainless steel

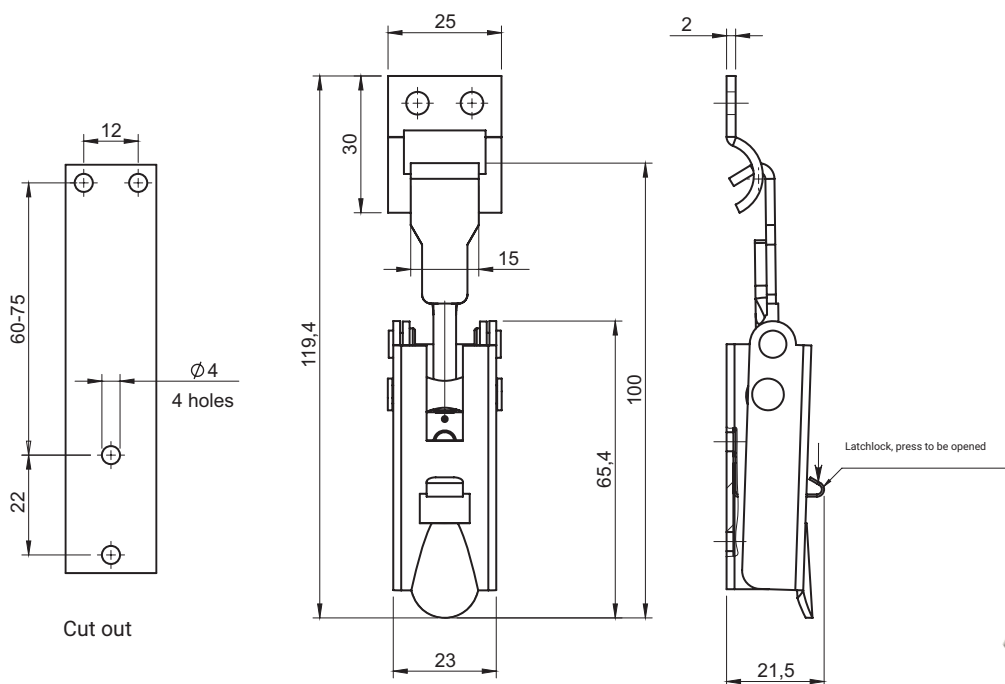

stainless steel

Latch supplied with a catch

CATALOGUE NUMBER	MATERIAL
3.ST210.001	Steel zinc plated
3.ST210.001SN	Stainless steel

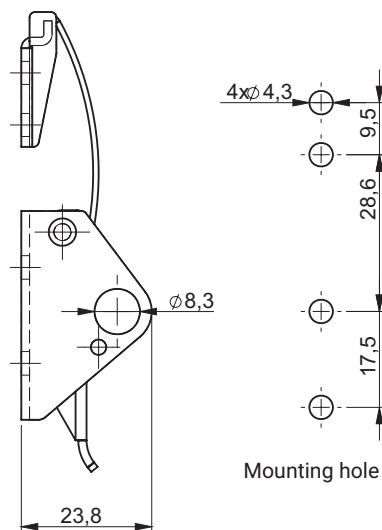
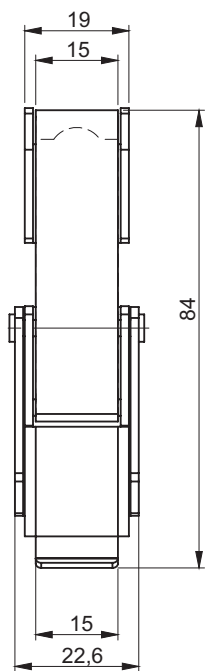

CATALOGUE NUMBER	DETAIL	MATERIAL
3.ST263.101	Latch secured with a padlock	Steel zinc plated
3.ST263.101SN		Stainless steel

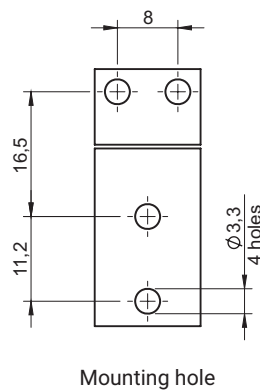
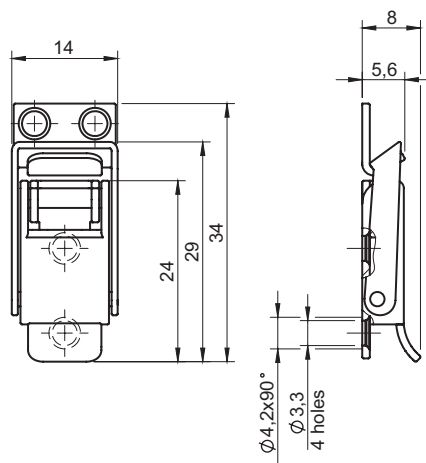

Latch supplied with a catch

CATALOGUE NUMBER	MATERIAL
3.561.001	Stainless steel

stainless steel

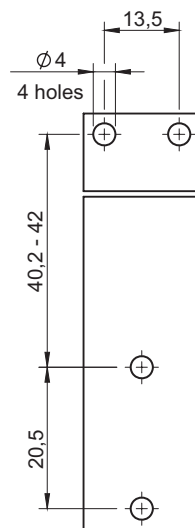
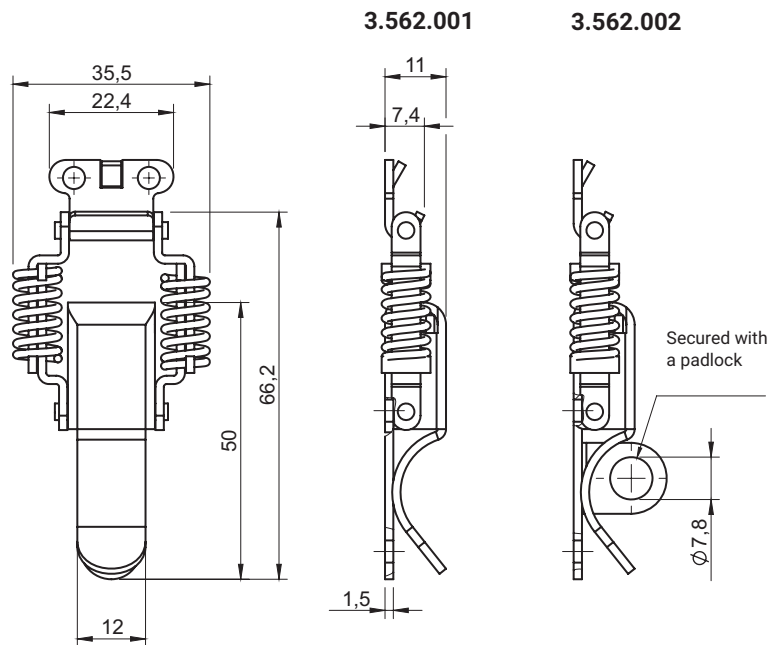

Mounting hole

Latch supplied with a catch

CATALOGUE NUMBER	MATERIAL
3.562.001	Stainless steel
3.562.002	Stainless steel

stainless steel

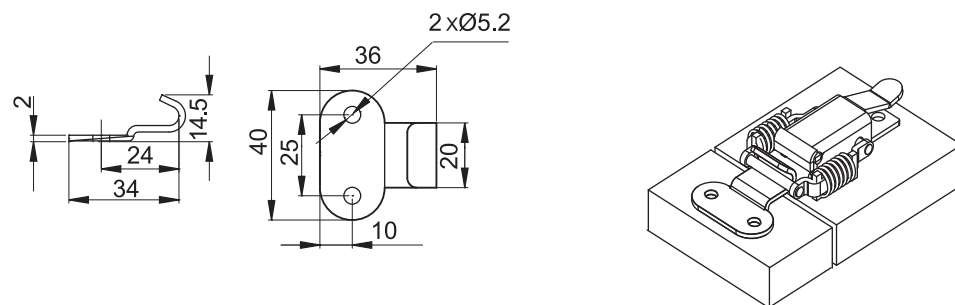
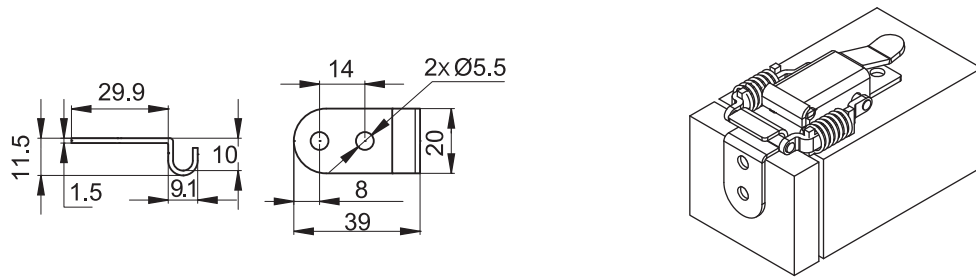
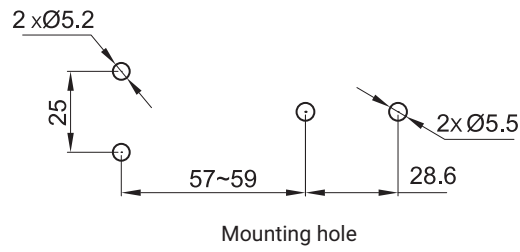
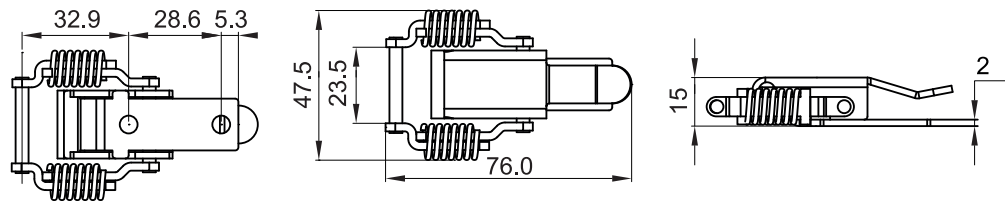
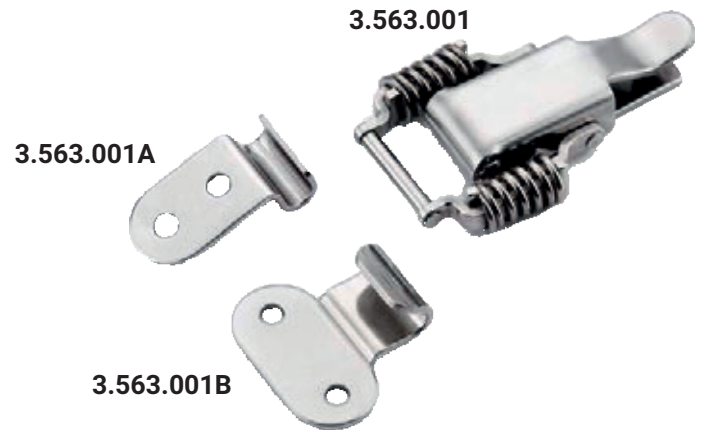

CATALOGUE NUMBER	MATERIAL
3.563.001	Stainless steel

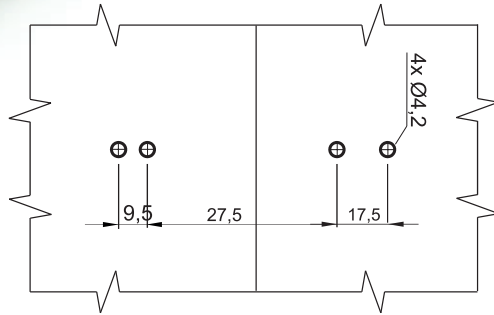
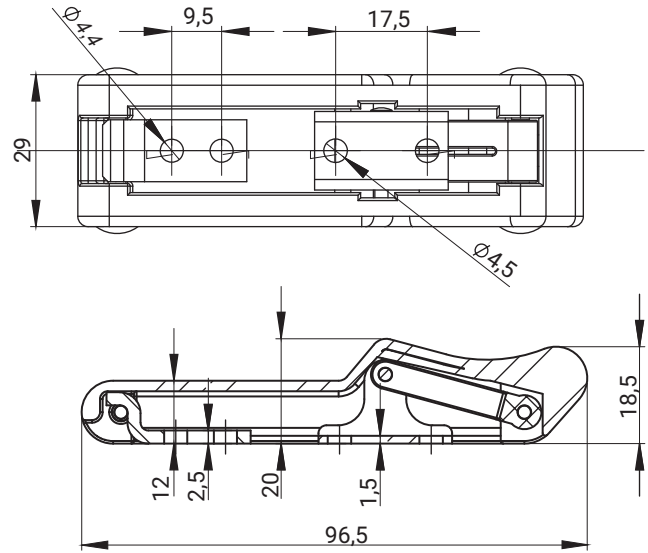

Mounting hole

CATALOGUE NUMBER	MATERIAL	FINISH [C]	
		4.490.001	Plastic - elastomer

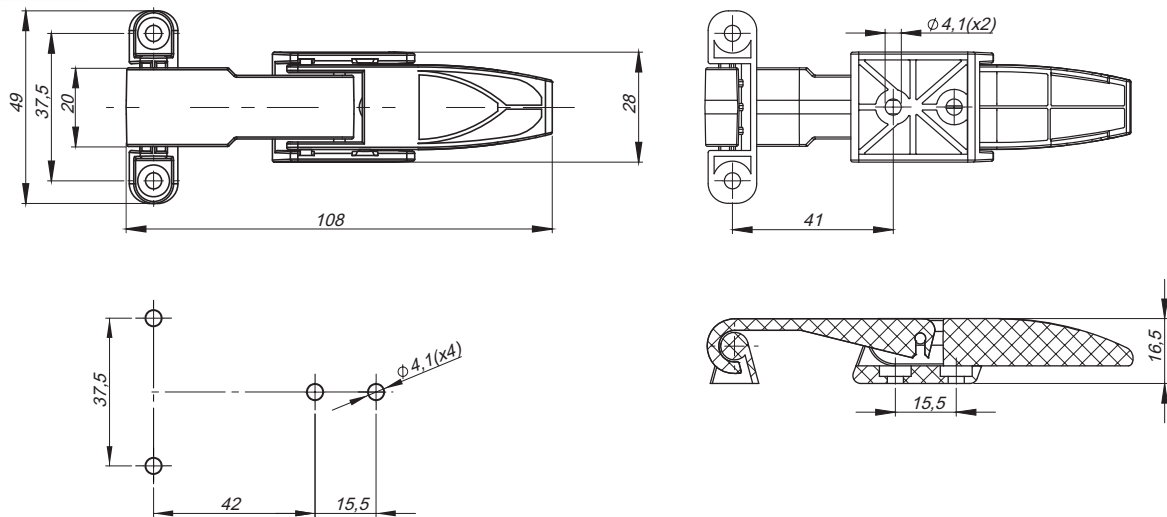

Mounting hole

CATALOGUE NUMBER	MATERIAL	FINISH [C]	
		4.491.001	PP
		07	08

How to order :

4.491.001 - C

Catalogue number
Finish

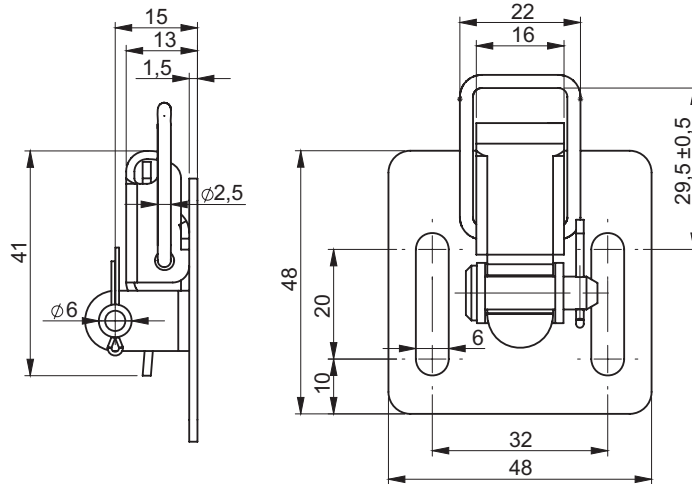

Latch with protection against unwanted opening.
 Latch compatible with a catch 3.ST200.003SN - ordered separately.

CATALOGUE NUMBER	MATERIAL
3.ST264.002	Steel zinc plated
3.ST264.002SN	Stainless steel

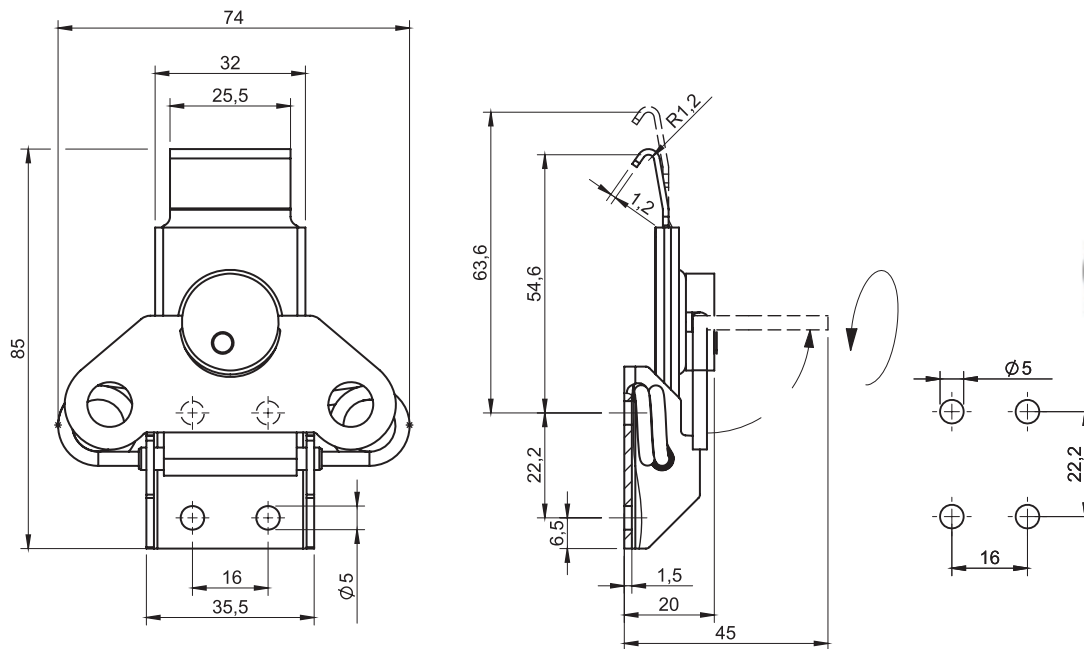

Latch opens by lifting the knob and turning counterclockwise.

CATALOGUE NUMBER	MATERIAL
3.ST267.001SN	Stainless steel

stainless steel

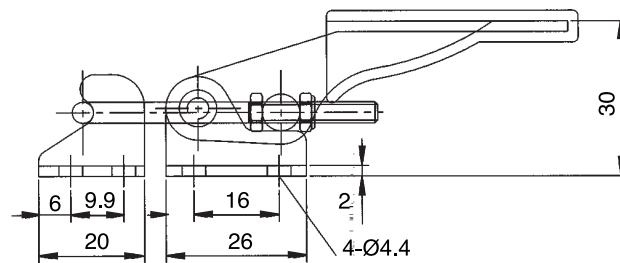
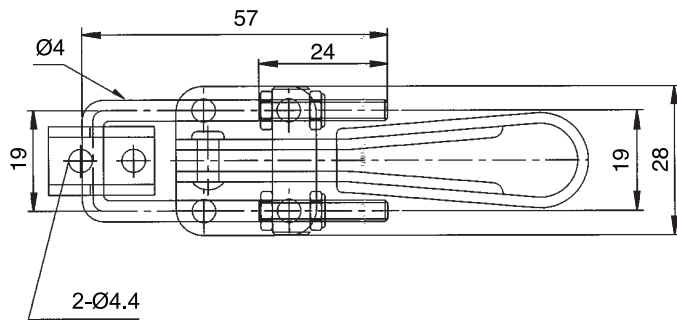
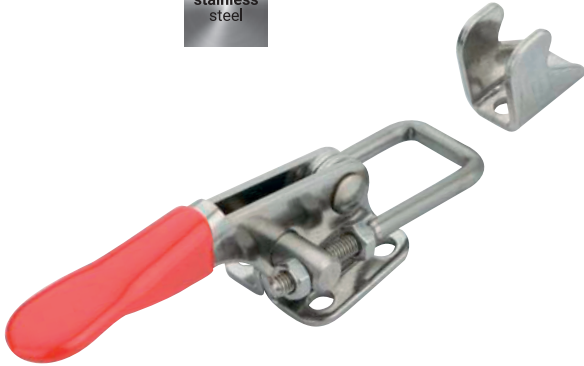

Note: Maximum load 160kg

CATALOGUE NUMBER	MATERIAL
3.565.001	Stainless steel

stainless steel

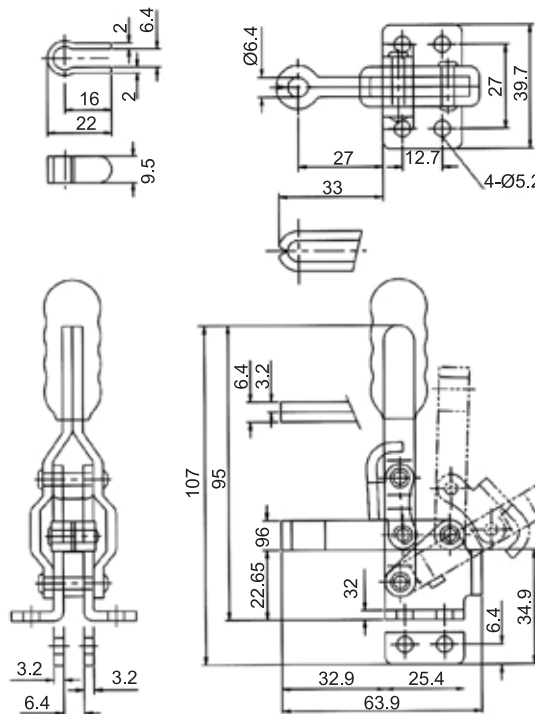

Note: Maximum load 95kg

CATALOGUE NUMBER	MATERIAL
3.566.001	Stainless steel

Latch 3.567 Bolt 4.700

stainless steel

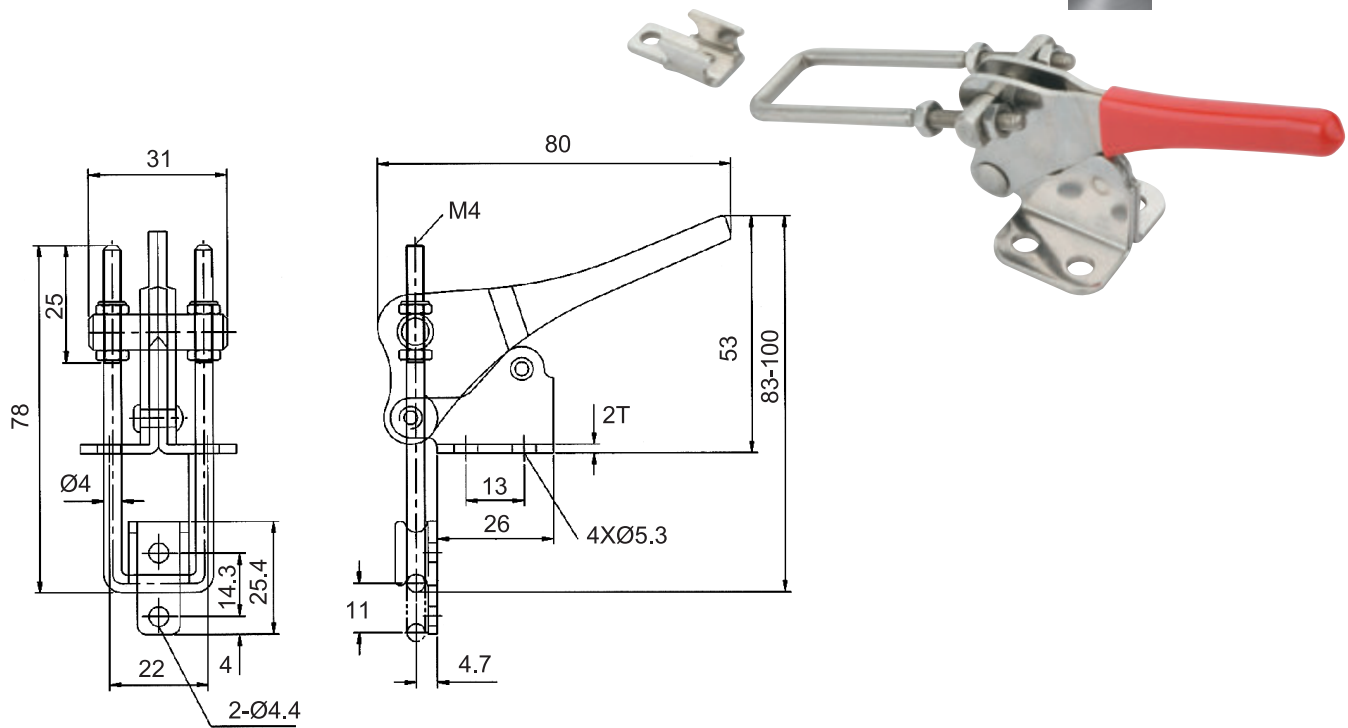

Note: Maximum load 225kg

CATALOGUE NUMBER	MATERIAL
3.567.001	Stainless steel

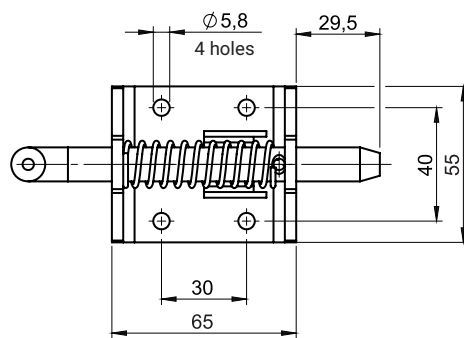
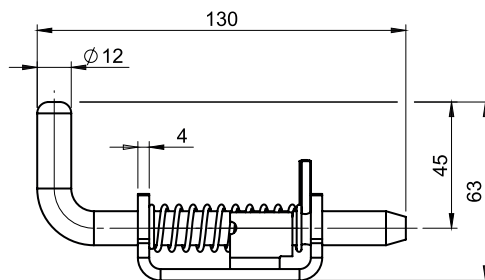

Locked Position

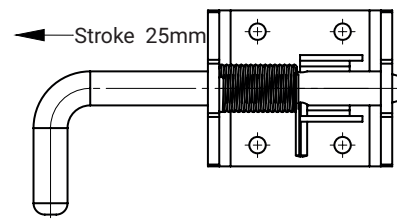

Open Position



CATALOGUE NUMBER	COMPONENTS	MATERIAL
4.700.001	Base Mount, Locking Pin	Steel zinc plated
	Spring	Stainless steel
4.700.001SN	Base Mount, Locking Pin	Stainless steel





1

Locking systems

2

Locks
Latches

3

External hinges

4

Clamps

5

Accessories

6

Gasketing profiles

7

Custom products

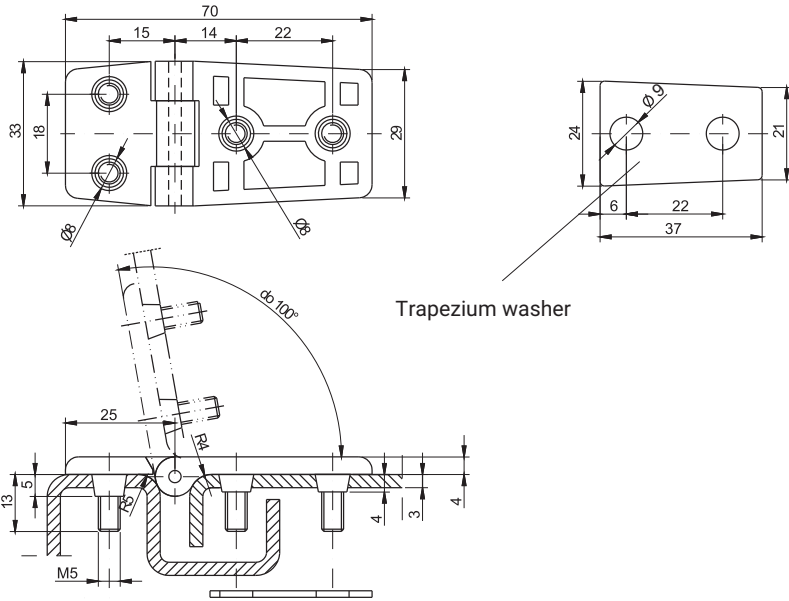
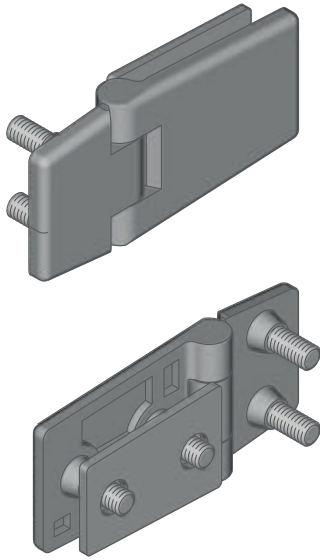

CATALOGUE NUMBER	COMPONENTS	MATERIAL	FINISH [C]	
			RAL 9005	RAL 7035
3.ZN1.001	Holder, Base	ZAMAK 5	04	05
	Pin	Brass		
	Washer, nut	Steel zinc plated		

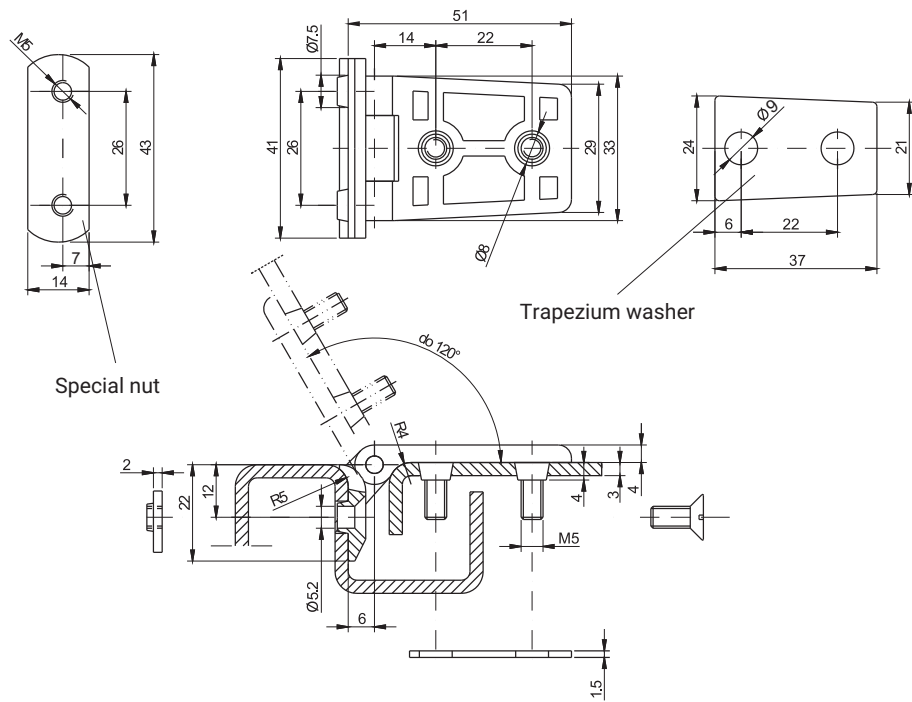
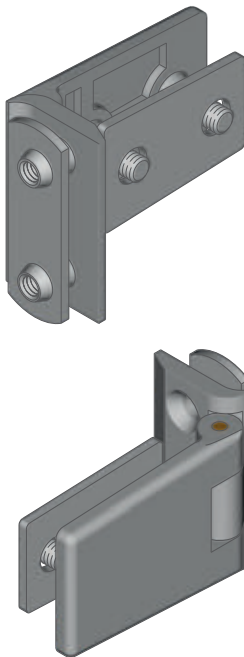

CATALOGUE NUMBER	COMPONENTS	MATERIAL	FINISH [C]	
			RAL 9005	RAL 7035
3.ZN2.001	Holder, Base	ZAMAK 5	04	05
	Pin	Brass		
	Washer, nut	Steel zinc plated		

How to order:

Catalogue number

Finish

3.ZN1.001 — C

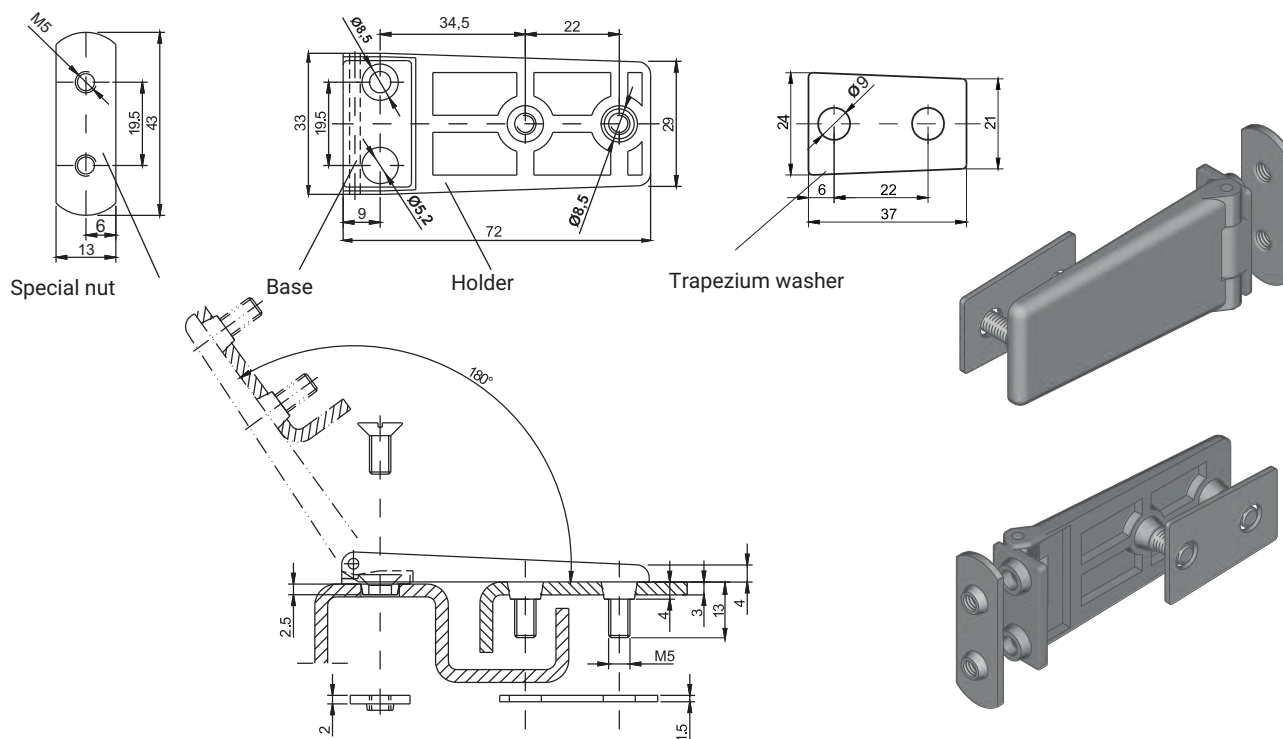

CATALOGUE NUMBER	COMPONENTS	MATERIAL	FINISH [C]	
			RAL 9005	RAL 7035
3.ZN3.001	Holder, Base,	ZAMAK 5	04	05
	Pin	Brass		
	Washer, nut	Steel zinc plated		

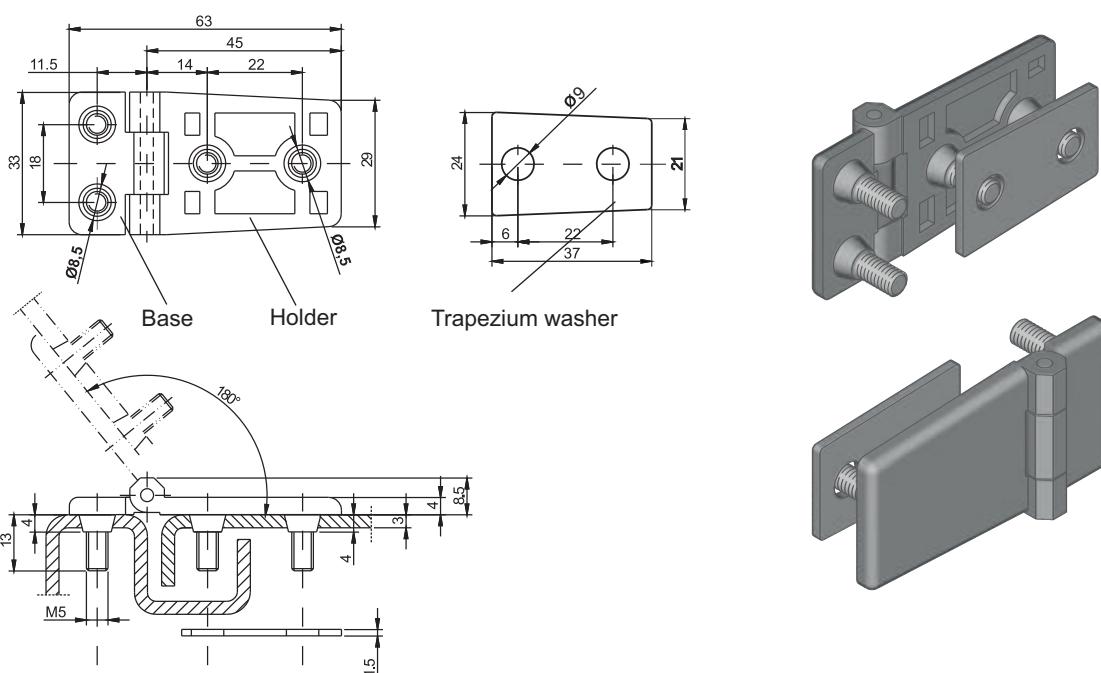

CATALOGUE NUMBER	COMPONENTS	MATERIAL	FINISH [C]	
			RAL 9005	RAL 7035
3.ZN4.001	Holder, Base,	ZAMAK 5	04	05
	Pin	Steel zinc plated		
	Washer			

How to order: 3.ZN3.001 — C

Catalogue number _____

Finish _____

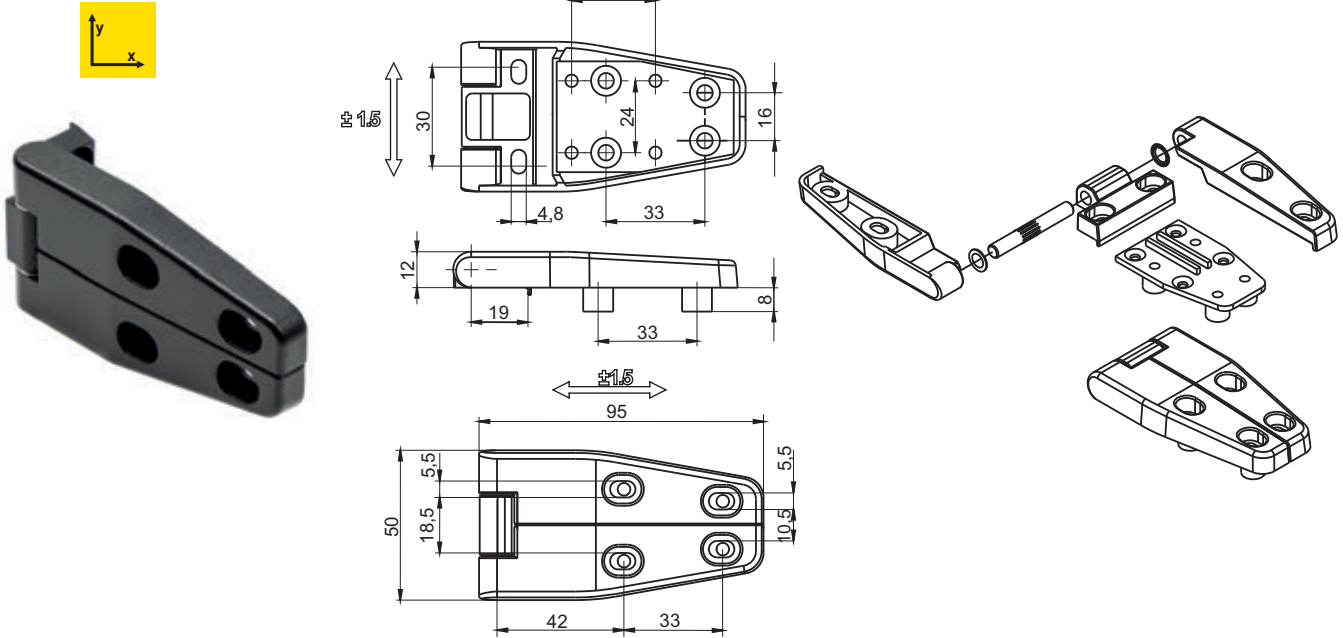

CATALOGUE NUMBER	COMPONENTS	MATERIAL	FINISH [C]	
			RAL 9005	RAL 7035
3.ZN115.001	Holder, Base,	ZAMAK 5	04	05
	Pin Washer, Nut	Steel zinc plated		

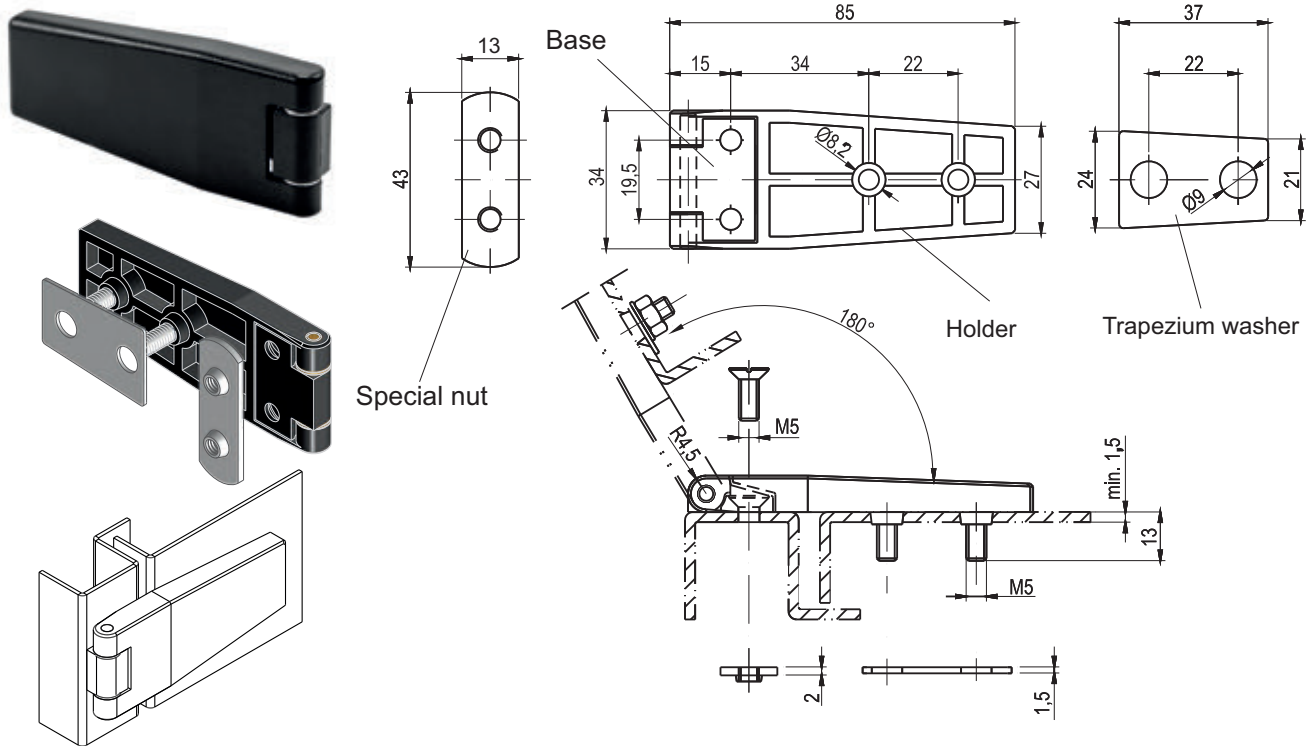

CATALOGUE NUMBER	COMPONENTS	MATERIAL	FINISH [C]	
			RAL 9005	RAL 7035
3.ZN110.001	Holder, Base,	ZAMAK 5	04	05
	Pin Washer, Nut	Steel zinc plated		

How to order:

Catalogue number 3.ZN115.001 — C
 Finish _____

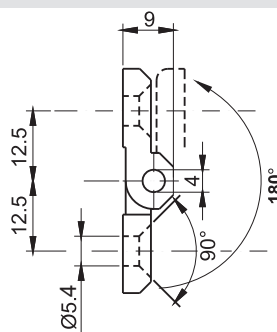
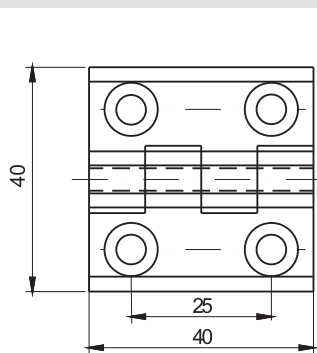

CATALOGUE NUMBER	COMPONENTS	MATERIAL	FINISH [C]			
			Chrome	RAL9005	RAL7035	Stainless steel
3.ZN60.001	Holder, Base	ZAMAK 5 *	01	04	05	-
	Pin	Stainless steel *				
3.ZN60.001PA	Holder, Base	Polyamide	-	07	-	-
	Pin	Stainless steel *				
3.ZN60.003SN	Holder, Base, Pin	Stainless steel polished	-	-	-	9.1

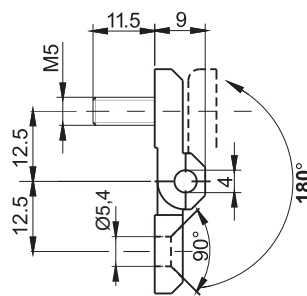
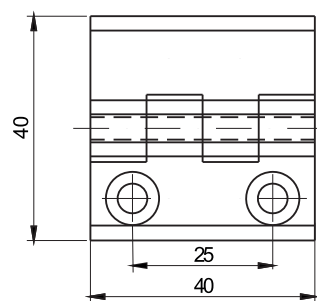

CATALOGUE NUMBER	COMPONENTS	MATERIAL	FINISH [C]		
			Chrome	RAL9005	RAL7035
3.ZN60.004	Holder, Base	ZAMAK 5 *	01	04	05
	Screw	Steel zinc plated *			
	Screw	Steel zinc plated *			

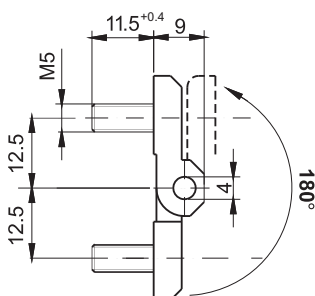
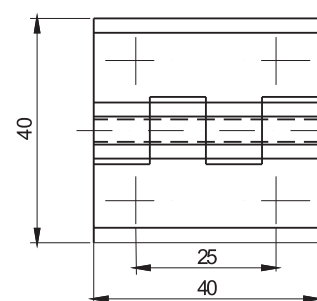

CATALOGUE NUMBER	COMPONENTS	MATERIAL	FINISH [C]		
			Chrome	RAL9005	RAL7035
3.ZN60.002	Holder, Base	ZAMAK 5 *	01	04	05
	Pin	Steel zinc plated *			
	Screw	Steel zinc plated *			

How to order:

Catalogue number
Finish

3.ZN60.001 — C

3.509.XY

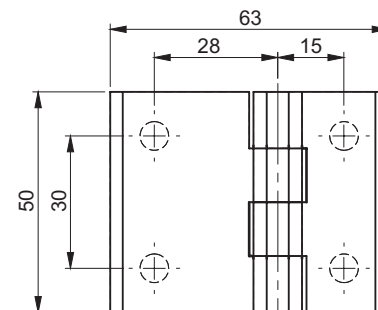
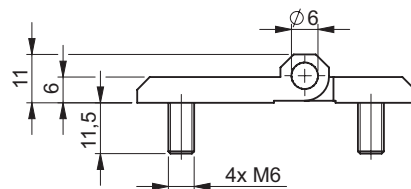
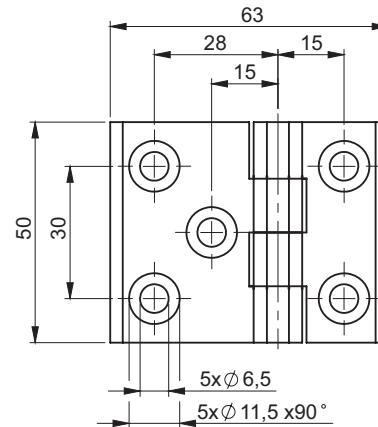
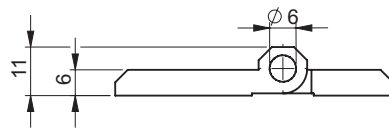
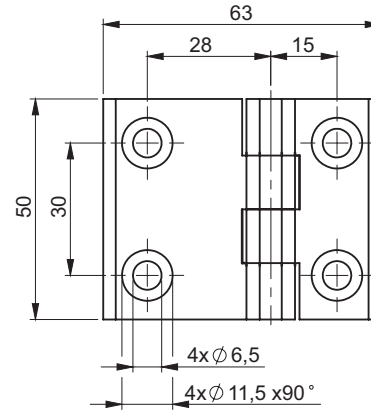
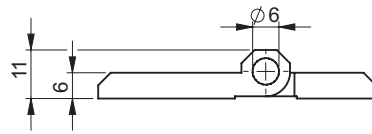

where:

X - the way of assembling the hinge

0 - version with 4 holes

1 - version with 5 holes

3 - version with 4 screw

Y - finish

1 - Chrome

2 - RAL 9005

HINGE	FINISH	
3.509.XY	01	02
	11	12
	31	32

CATALOGUE NUMBER	COMPONENTS	MATERIAL
3.509.XY	Holder, Base	ZAMAK 5
	Pin	Stainless steel
	Screw	Steel zinc plated

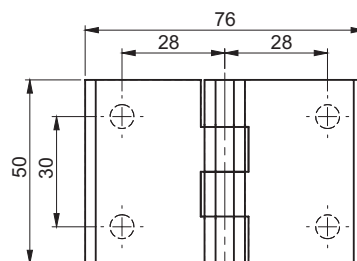
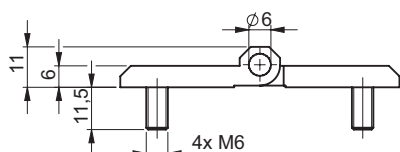
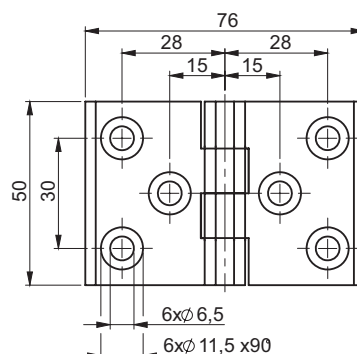
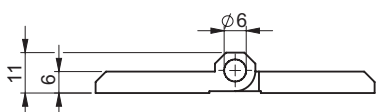
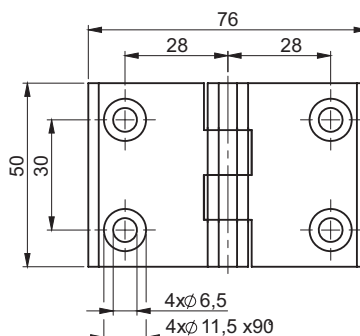
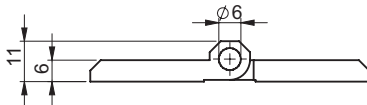
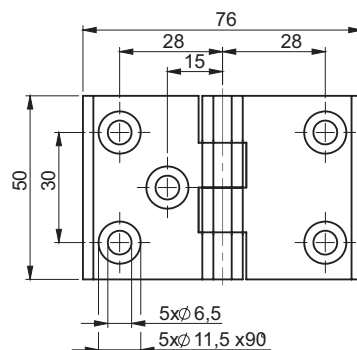
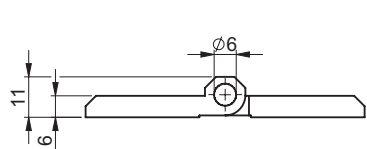

where:

X - the way of assembling the hinge

0 - version with 4 holes

1 - version with 5 holes

2 - version with 6 holes

3 - version with 4 screw

Y - finish

1 - Chrome

2 - RAL 9005

3 - Polyamide

HINGE		FINISH	
3.510.XY	01	02	-
	11	12	-
	21	22	23
	31	32	-

CATALOGUE NUMBER	COMPONENTS	MATERIAL
3.510.XY	Holder, Base	ZAMAK 5/ Polyamide
	Pin	Stainless steel
	Screw	Steel zinc plated

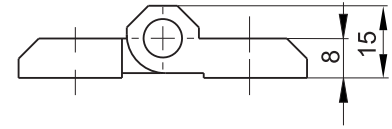
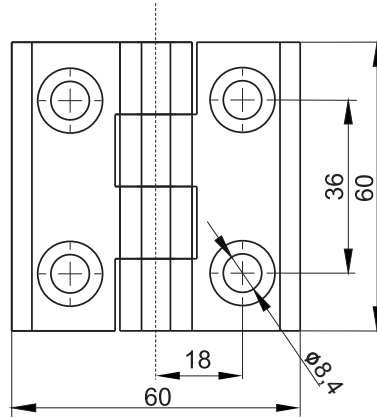

Use screws M8 DIN965

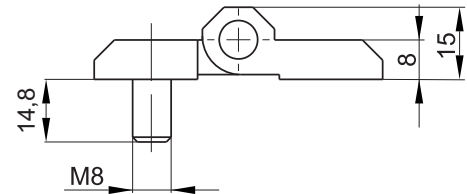
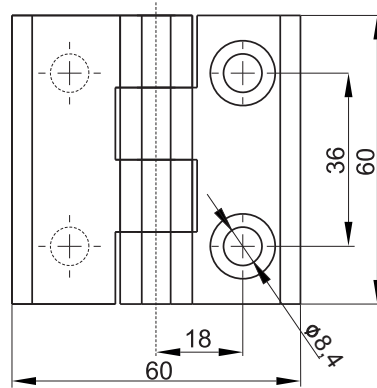
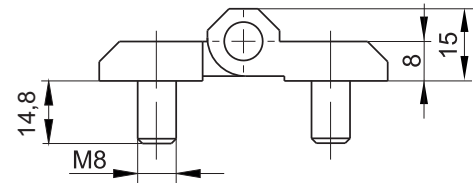
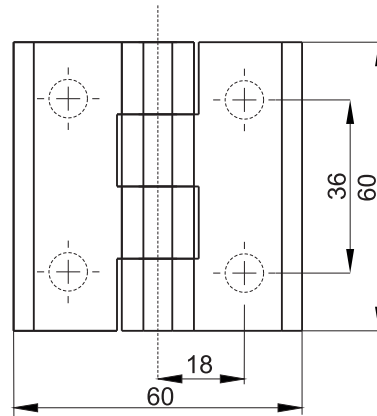

where:

X - the way of assembling the hinge

1 - version with 4 holes

2 - version with 4 threaded pins

3 - version with 2 holes and 2

Y - finish

1 - Chrome

2 - RAL 9005

HINGE	FINISH	
	3.511.XY	11
21		22
31		32

CATALOGUE NUMBER	COMPONENTS	MATERIAL
3.511.XY	Holder, Base	ZAMAK 5
	Pin	Steel zinc plated

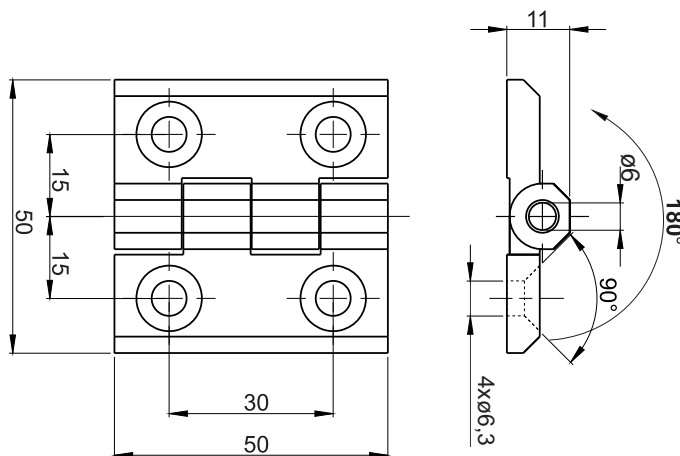

stainless steel



CATALOGUE NUMBER	COMPONENTS	MATERIAL	FINISH [C]		
			Chrome	RAL9005	RAL7035
3.ZN65.001	Holder, Base	ZAMAK 5 *	01	04	05

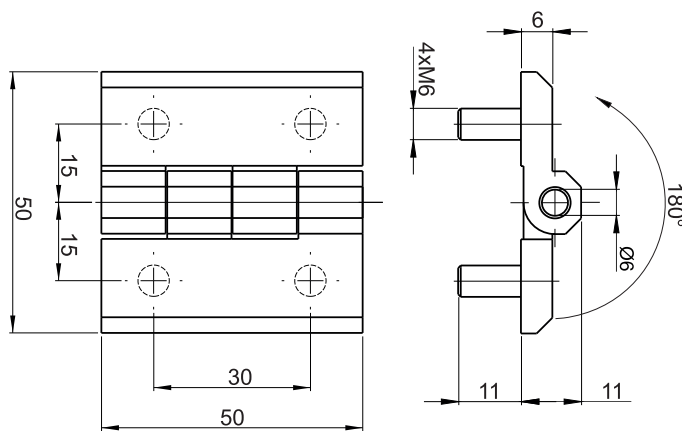

CATALOGUE NUMBER	COMPONENTS	MATERIAL	FINISH [C]		
			Chrome	RAL9005	RAL7035
3.ZN65.002	Holder, Base	ZAMAK 5*	01	04	05
	Screw	Steel zinc plated*			

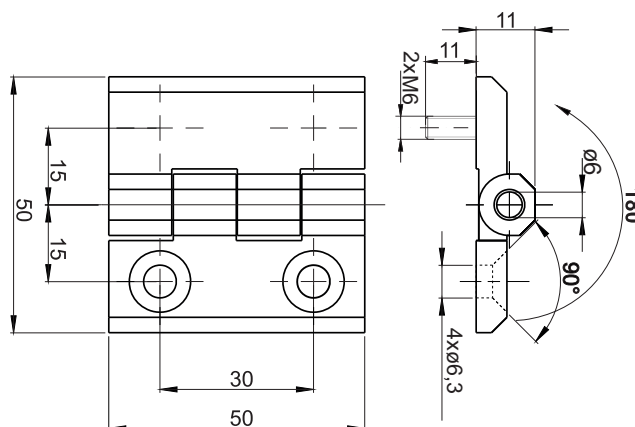

CATALOGUE NUMBER	COMPONENTS	MATERIAL	FINISH [C]		
			Chrome	RAL9005	RAL7035
3.ZN65.003	Holder, Base	ZAMAK 5*	01	04	05
	Screw	Steel zinc plated*			

How to order:

Catalogue number
Finish

3.ZN65.001 — C

Polyamide hinge 3.ZN30, 3.ZN60, 3.ZN65

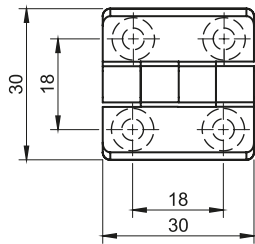

3.ZN30.101

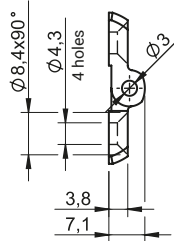

3.ZN30.102

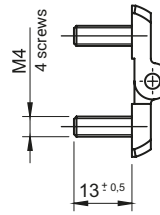

3.ZN30.103

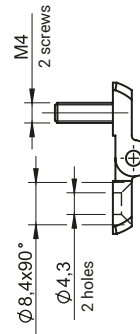

CATALOGUE NUMBER	COMPONENTS	MATERIAL	FINISH [C]
			RAL 9005
3.ZN30.101	Holder, Base	Polyamide	07
3.ZN30.102	Pin	Stainless steel	-
3.ZN30.103	Screws	Steel zinc plated	-

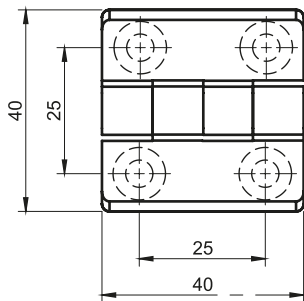

3.ZN60.101

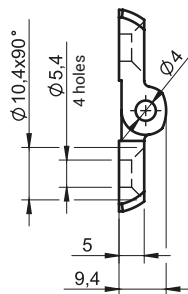

3.ZN60.102

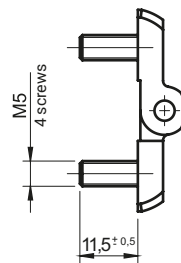

3.ZN60.103

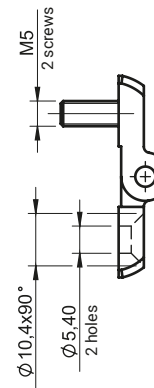

CATALOGUE NUMBER	COMPONENTS	MATERIAL	FINISH [C]
			RAL 9005
3.ZN60.101	Holder, Base	Polyamide	07
3.ZN60.102	Pin	Stainless steel	-
3.ZN60.103	Screws	Steel zinc plated	-

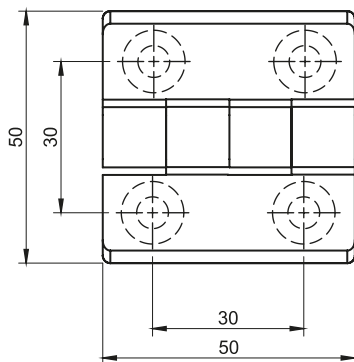

3.ZN65.101

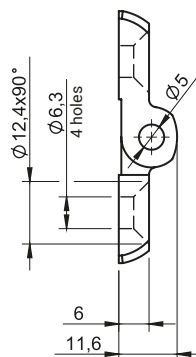

3.ZN65.102

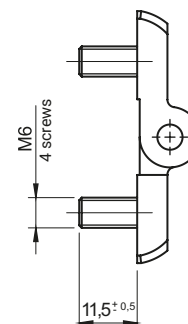

3.ZN65.103

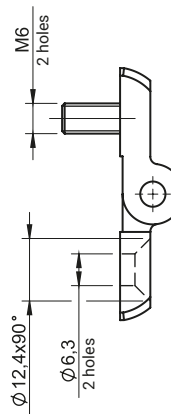

CATALOGUE NUMBER	COMPONENTS	MATERIAL	FINISH [C]
			RAL 9005
3.ZN65.101	Holder, Base	Polyamide	07
3.ZN65.102	Pin	Stainless steel	-
3.ZN65.103	Screws	Steel zinc plated	-

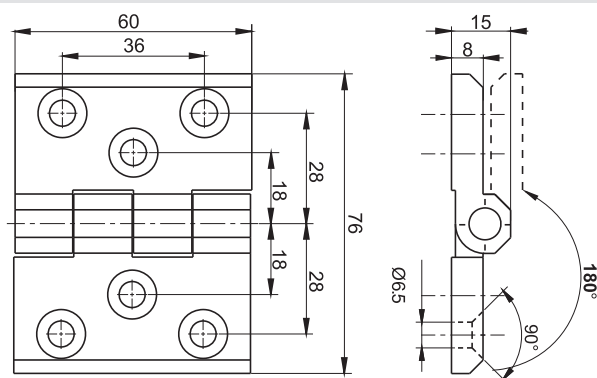

CATALOGUE NUMBER	COMPONENTS	MATERIAL	FINISH [C]		
			Chrome	RAL9005	RAL7035
3.ZN66.001	Holder, Base	ZAMAK 5	01	04	05
	Pin	Stainless steel			

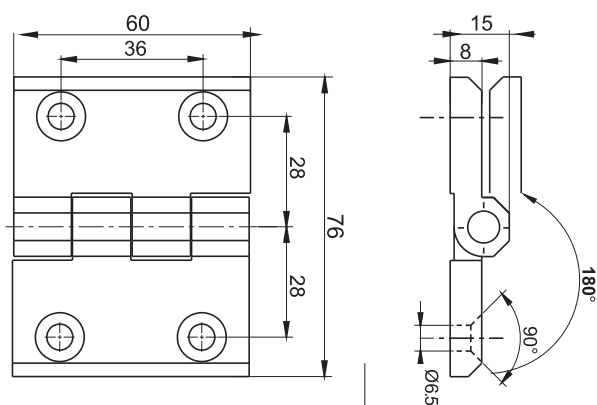

CATALOGUE NUMBER	COMPONENTS	MATERIAL	FINISH [C]		
			Chrome	RAL9005	RAL7035
3.ZN66.002	Holder, Base	ZAMAK 5	01	04	05
	Pin	Stainless steel			

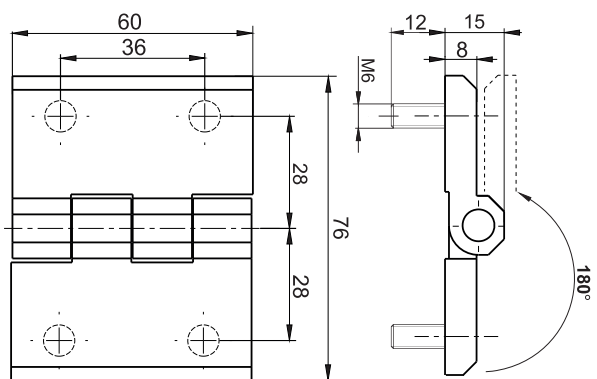

CATALOGUE NUMBER	COMPONENTS	MATERIAL	FINISH [C]	
	Holder, Base	ZAMAK 5	RAL9005	RAL7035
	Screw	Steel zinc plated*	04	05
Pin	Stainless steel			

How to order:

Catalogue number
Finish

3.ZN66.001 — C



X=1

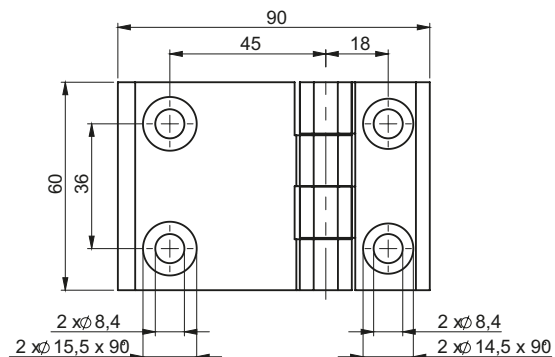
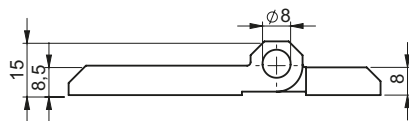

X=2

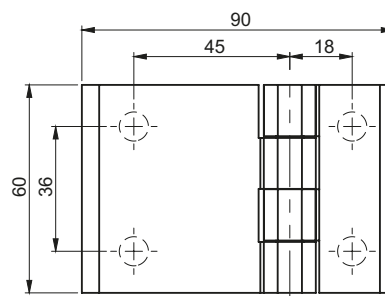
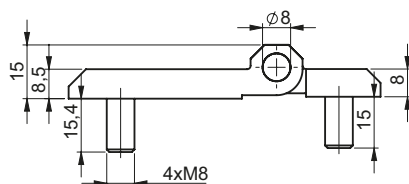

X=3

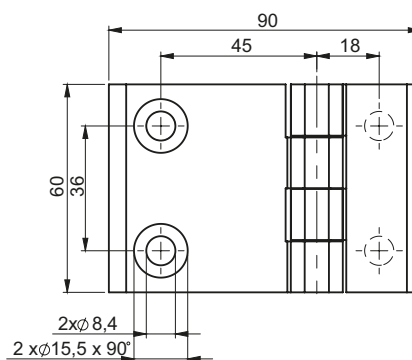
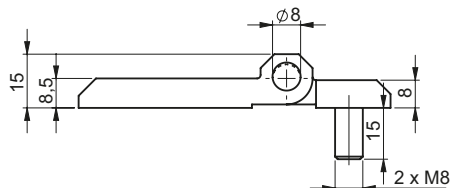

X=4

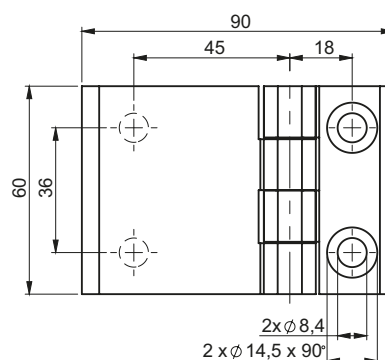
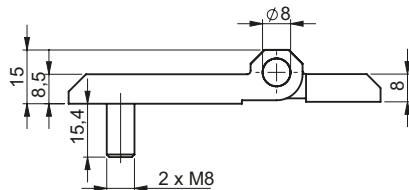

where:

- X** - the way of assembling the hinge
 - 1 - version with 4 holes
 - 2 - version with 4 threaded pins
 - 3 - version with 2 holes and 2 threaded pins
 - 4 - version with 2 threaded pins and 2 holes

- Y** - finish
 - 1 - Chrome
 - 2 - RAL 9005

HINGE	FINISH	
	3.512.XY	11
21		22
31		32
41		42

CATALOGUE NUMBER	COMPONENTS	MATERIAL
3.512.XY*	Holder, Base	ZAMAK 5
	Pin	Stainless steel

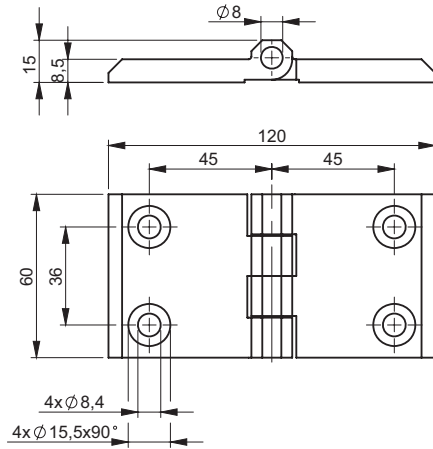

Use screws
M8 DIN965

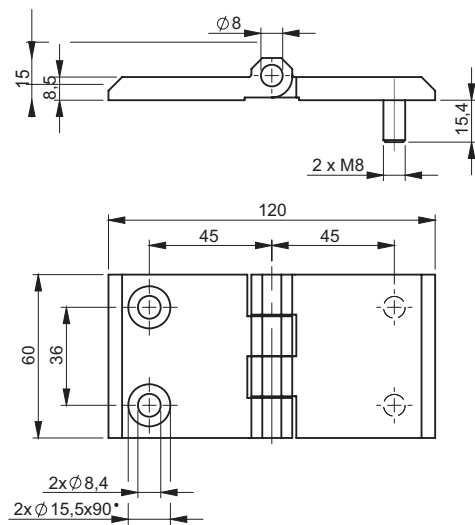
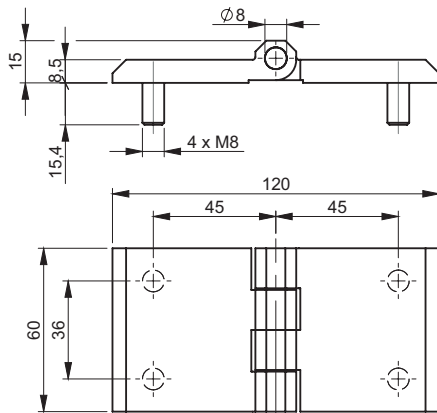

HINGE	FINISH	
	3.513.XY	11
21		22
31		32

where:

- X** - the way of assembling the hinge
 - 1 - version with 4 holes
 - 2 - version with 4 threaded pins
 - 3 - version with 2 holes and 2 threaded pins

- Y** - finish
 - 1 - Chrome
 - 2 - RAL 9005

CATALOGUE NUMBER	COMPONENTS	MATERIAL
3.513.XY	Holder, Base	ZAMAK 5
	Pin	Steel zinc plated

stainless steel

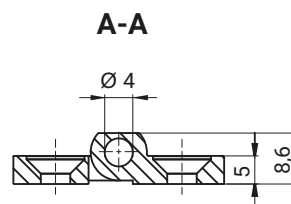
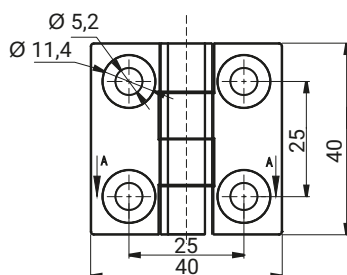

CATALOGUE NUMBER	COMPONENTS	MATERIAL	FINISH
3.541.001SN	Holder, Base	Stainless steel	Burnished

stainless steel

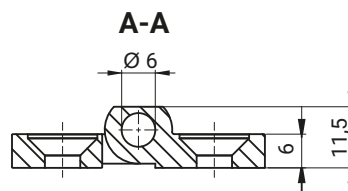
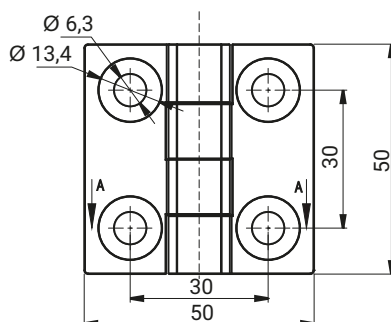

CATALOGUE NUMBER	COMPONENTS	MATERIAL	FINISH
3.541.002SN	Holder, Base	Stainless steel	Burnished

stainless steel

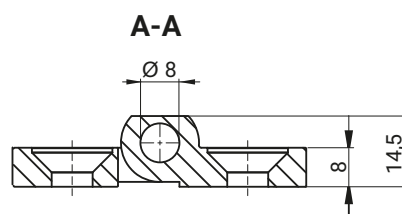
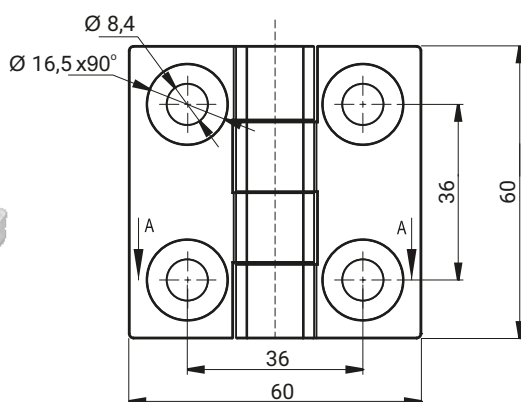

CATALOGUE NUMBER	COMPONENTS	MATERIAL	FINISH
3.541.003SN	Holder, Base	Stainless steel	Burnished

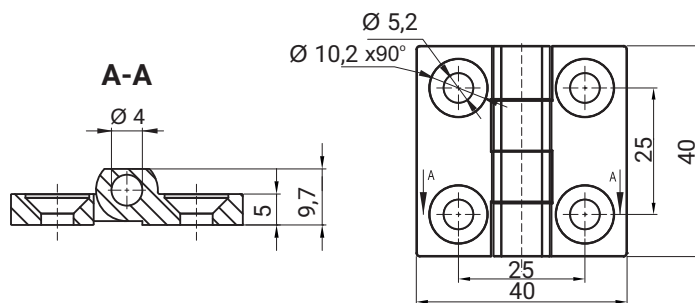

CATALOGUE NUMBER	COMPONENTS	MATERIAL	FINISH [C]
			RAL 9005
3.540.001SN	Holder, Base	Stainless steel	04

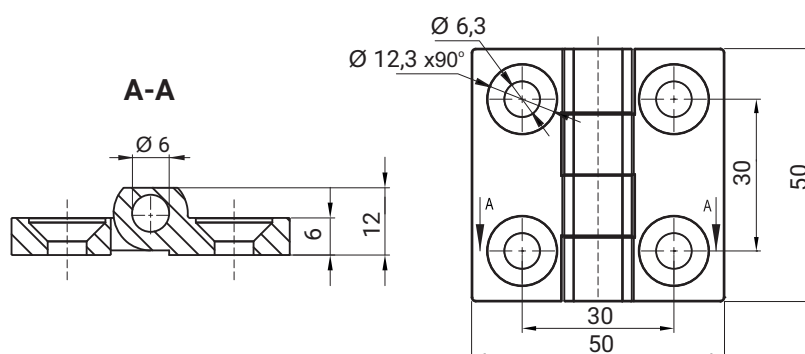

CATALOGUE NUMBER	COMPONENTS	MATERIAL	FINISH [C]
			RAL 9005
3.540.002SN	Holder, Base	Stainless steel	04

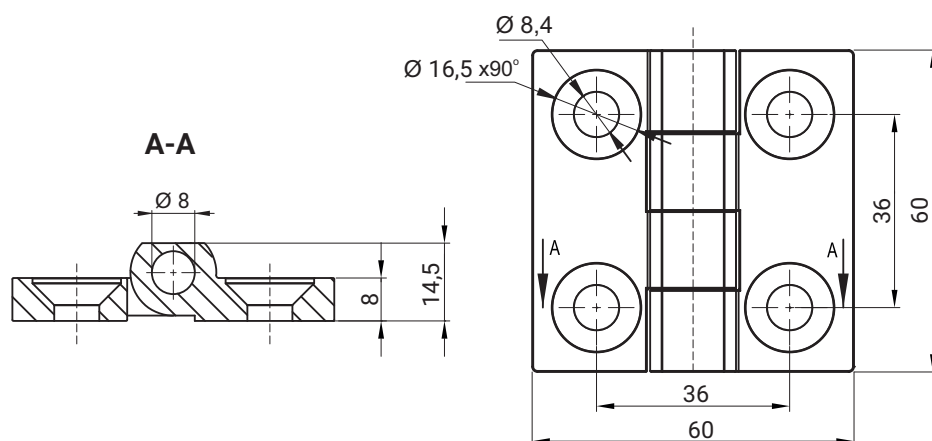

CATALOGUE NUMBER	COMPONENTS	MATERIAL	FINISH [C]
			RAL 9005
3.540.003SN	Holder, Base	Stainless steel	04

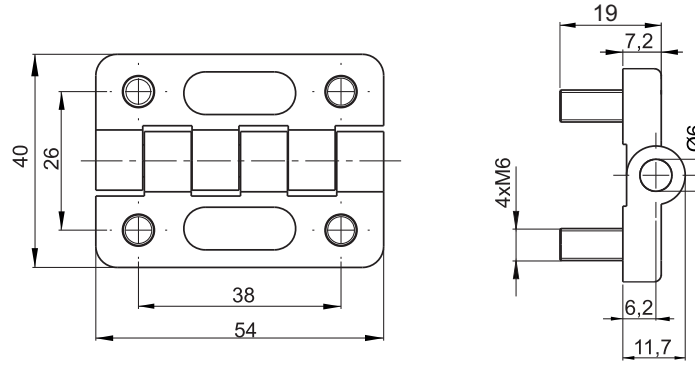

CATALOGUE NUMBER	COMPONENTS	MATERIAL	FINISH [C]	
			RAL 9005	
3.ZN68.001*	Holder, Base	ZAMAK 5	04	
	Pin	Steel zinc plated		



VERSION LEFT

3.ZN67.002
3.ZN67.004

VERSION RIGHT

3.ZN67.001
3.ZN67.003

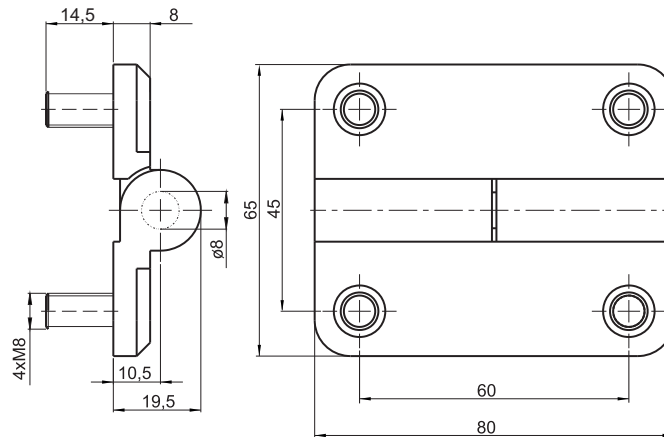

CATALOGUE NUMBER	COMPONENTS	MATERIAL	FINISH [C]	
			RAL 9005	RAL 7035
3.ZN67.001*	Holder, Base	ZAMAK 5	04	-
3.ZN67.002*	Pin	Steel zinc plated		
3.ZN67.003*	Holder, Base	ZAMAK 5	-	05
3.ZN67.004*	Pin	Steel zinc plated		

* possibility to order stainless steel pin.

How to order:

Catalogue number _____
Finish _____

3.ZN67.001 — C

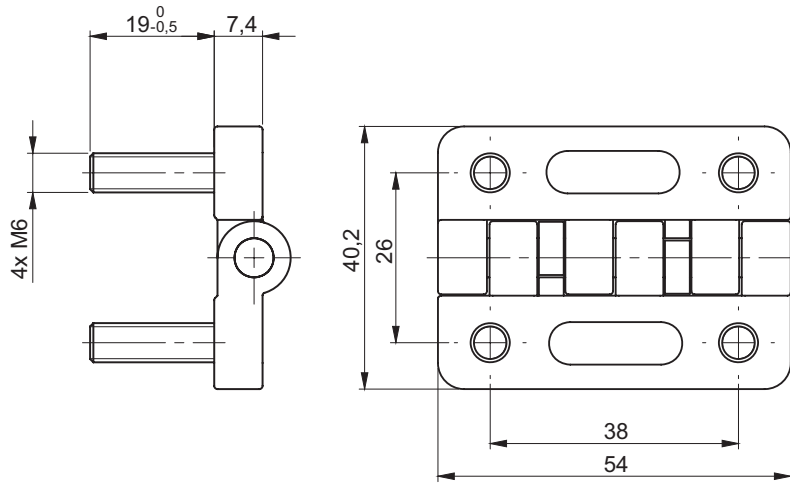

Type	Friction torque
3.543.001	47kg.cm ± 15%
3.543.002	12kg.cm ± 15%

CATALOGUE NUMBER	COMPONENTS	MATERIAL	FINISH [C]
			RAL 9005
3.543.001	Holder, Base	ZAMAK5	04
3.543.002	Pin	Stainless steel	-

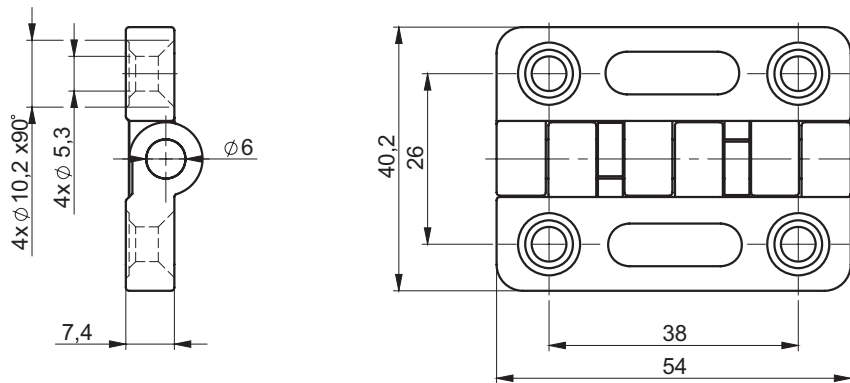

Type	Friction torque
3.543.101	47kg.cm ± 15%
3.543.102	12kg.cm ± 15%

CATALOGUE NUMBER	COMPONENTS	MATERIAL	FINISH [C]
			RAL 9005
3.543.101	Holder, Base	ZAMAK5	04
3.543.102	Holder, Base	ZAMAK5	04

Hinges with linear course of frictional resistance.

How to order:
 Catalogue number 3.543.001
 Finish C

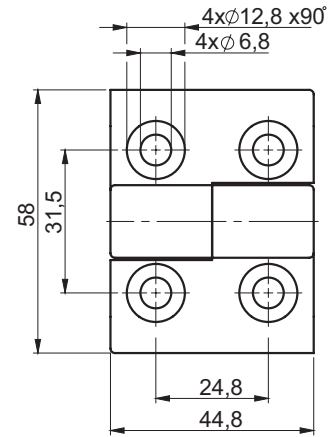
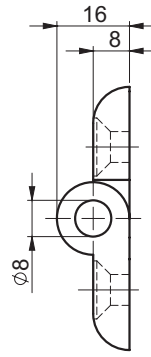
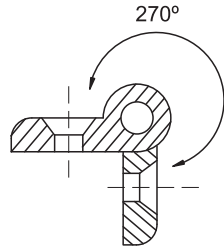

CATALOGUE NUMBER	VERSION	COMPONENTS	MATERIAL	FINISH [C]
				RAL 9005
3.544.001	Right	Holder, Base	Polyamide	07
3.544.002	Left			-

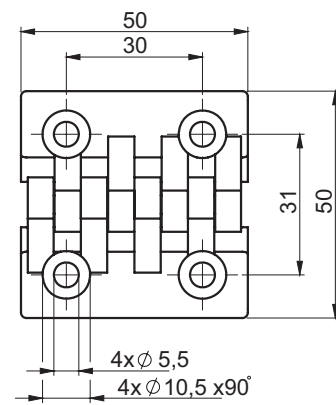
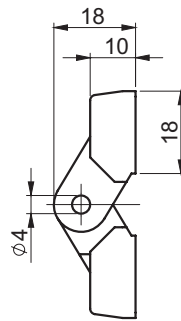
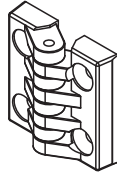

CATALOGUE NUMBER	COMPONENTS	MATERIAL	FINISH [C]
			RAL 9005
3.545.001	Holder, Base	Polyamide	07
	Pin	Steel zinc plated	-

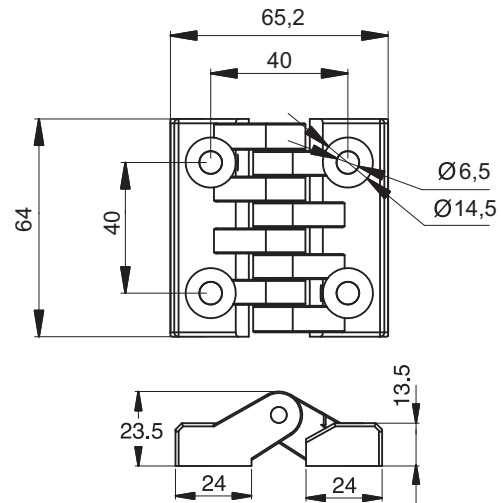
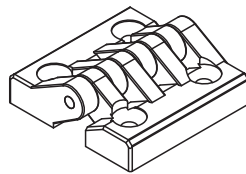

CATALOGUE NUMBER	COMPONENTS	MATERIAL	FINISH [C]
			RAL 9005
3.545.002	Holder, Base	Polyamide	07
	Pin	Steel zinc plated	-

How to order:

Catalogue number

Finish

3.545.001

C

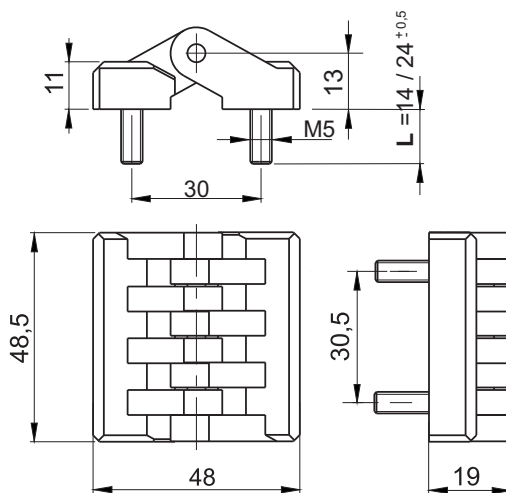

CAT. NUMBER	DIMENSION L	COMPONENTS	MATERIAL	FINISH [C]	
				07	08
3.ZN48-PA.001	14	Holder, Base	Polyamide Pa6	07	
3.ZN48-PA.101	24	Pin, Studs	Steel zinc plated		
3.ZN48-PA.102 SN	14	Holder, Base	Polyamide Pa6		
3.ZN48-PA.103 SN	24	Pin, Studs	Stainless steel		

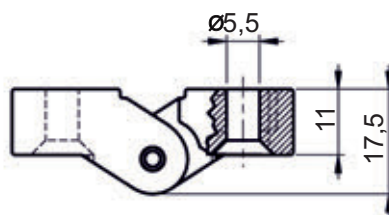
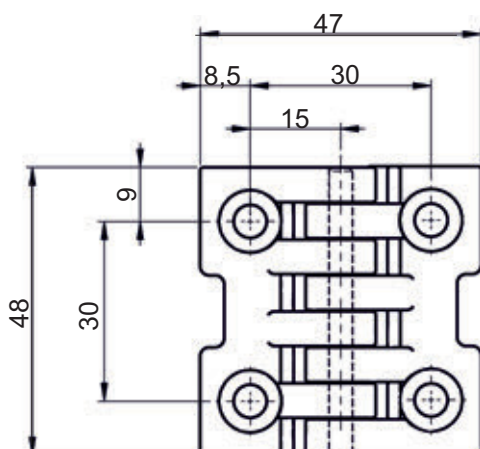

CATALOGUE NUMBER	COMPONENTS	MATERIAL	FINISH [C]	
			RAL9005	RAL7035
3.527.001	Holder, Base	Polyamide	07	08
	Pin	Steel zinc plated		

How to order:
 Catalogue number: 3.526.001 — C
 Finish: C

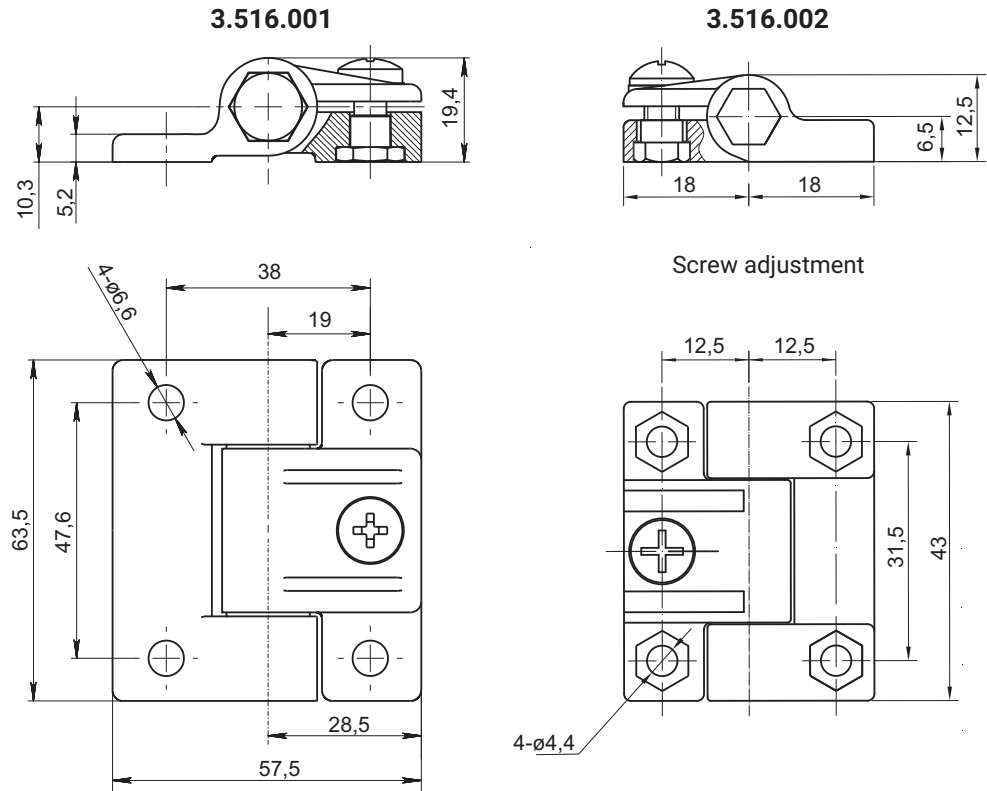

CATALOGUE NUMBER	COMPONENTS	MATERIAL	FINISH [C]
			RAL 9005
3.516.001	Holder, Base	Polyamide	07
3.516.002	Pin	Steel zinc plated	-

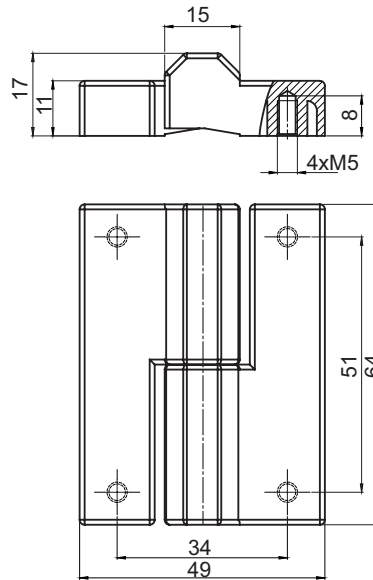

CATALOGUE NUMBER	VERSION	COMPONENTS	MATERIAL	FINISH [C]		
				Chrome	RAL9005	RAL7035
3.526.001	RIGHTS	Holder, Base	ZAMAK 5	01	04	05
3.526.002	LEFT	Pin	Steel zinc plated			

How to order:

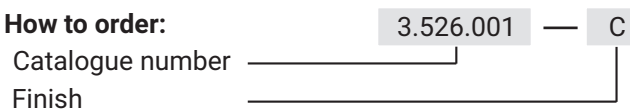

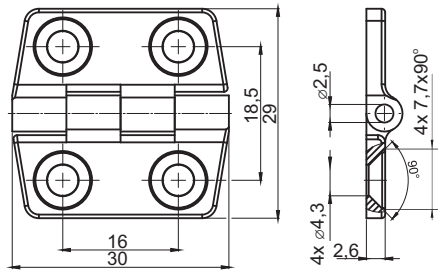

CATALOGUE NO.	COMPONENTS	MATERIAL	FINISH [C]
			RAL 9005
3.ZN10.001	Holder, Base,	ZAMAK5	04
	Pin	Steel zinc plated	

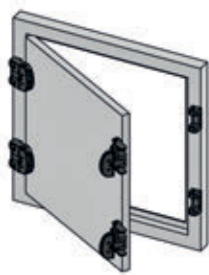
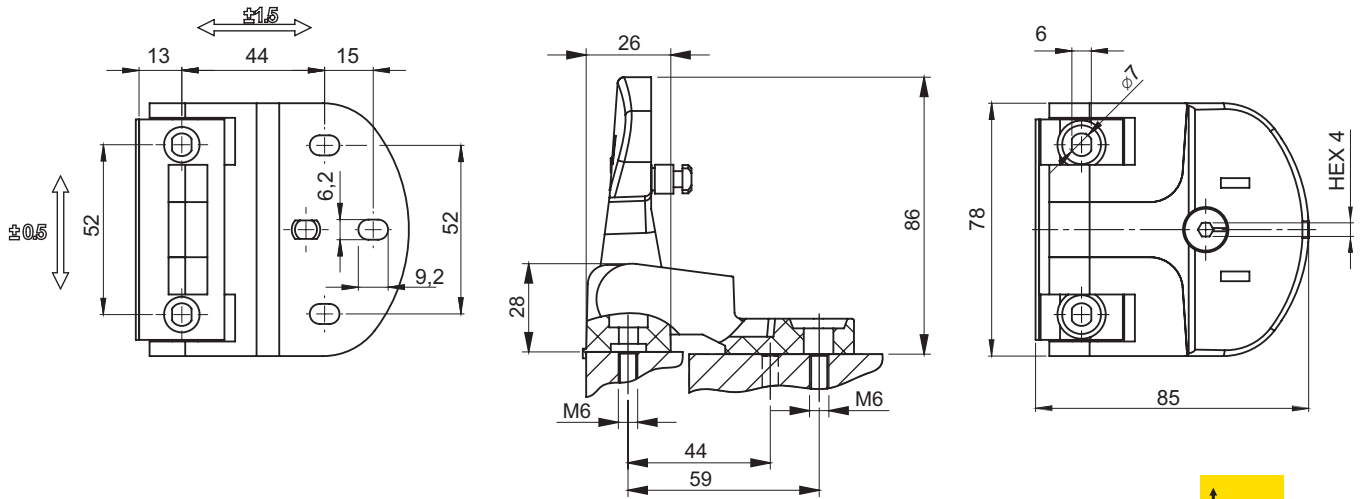

Opening the left

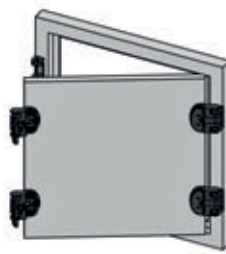

Opening the right

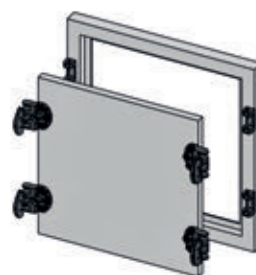

Removing the door



CATALOGUE NO.	DETAIL	MATERIAL	FINISH [C]
			RAL 9005
3.ZN200.001	Hinge with lock function	Polyamide	07

How to order:

Catalogue number

Finish

3.ZN10.001 — C

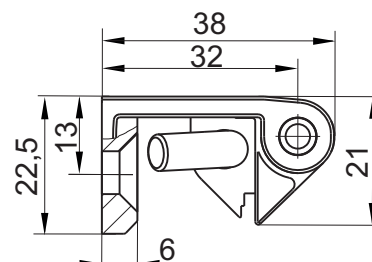
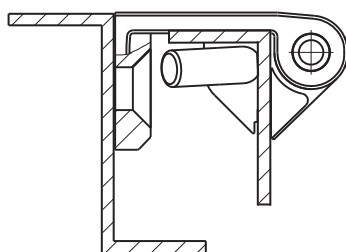
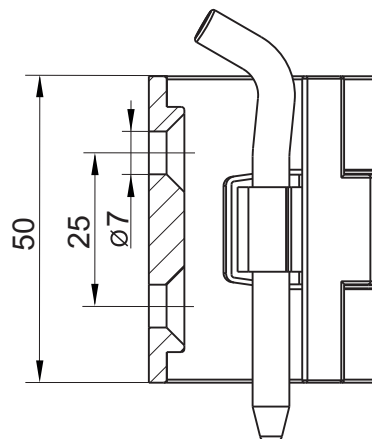
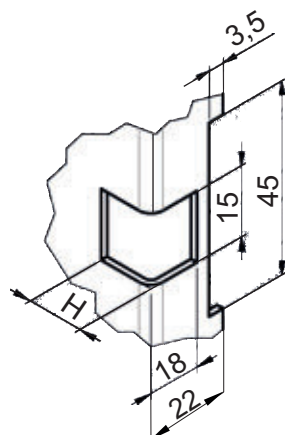

H [mm]	APPLICATION
13	only sheets 1,5 mm
15	only sheets 2 mm

CATALOGUE NUMBER	COMPONENTS	MATERIAL	FINISH [C]		
			Chrome	RAL 9005	RAL 7035
3.ZN105.001*	Holder, Base	ZAMAK 5	01	04	05
	Pin	Steel zinc plated			

* possibility to order stainless steel pin.
When ordering, specify the color or finishing type

How to order:
 Catalogue number 3.ZN105.001
 Finish C

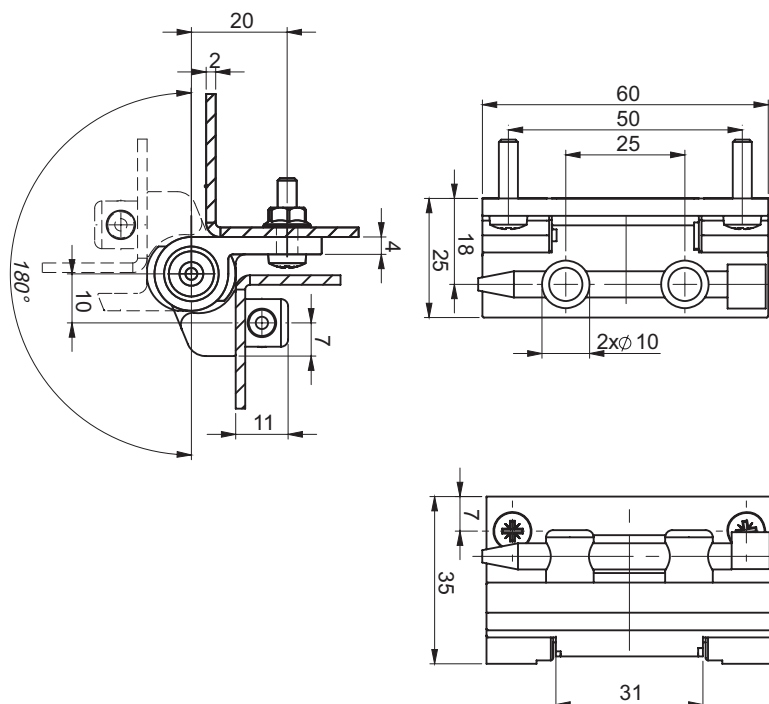

CATALOGUE NUMBER	COMPONENTS	MATERIAL	FINISH [C]	
			Chrome	RAL 9005
3.529.001*	Holder, Base	ZAMAK 5	01	04
	Pin	Steel zinc plated,*		

* possible to order stainless steel pin.

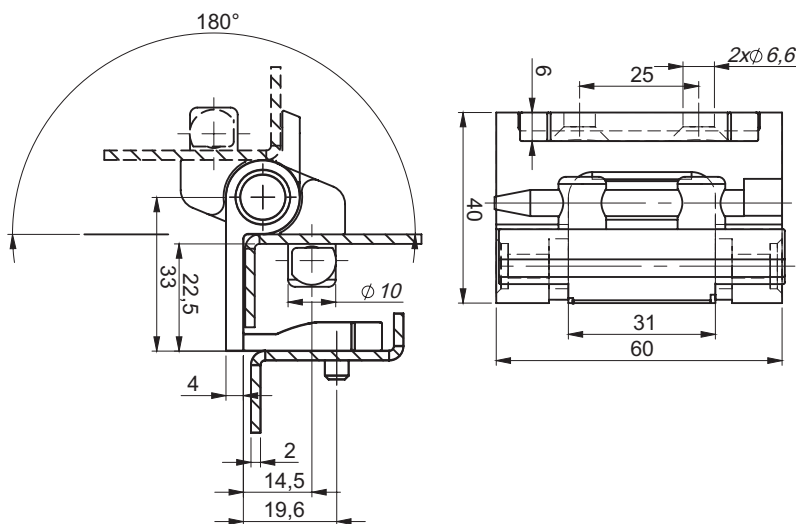

CATALOGUE NUMBER	COMPONENTS	MATERIAL	FINISH [C]	
			Chrome	RAL 9005
3.530.001**	Holder, Base	ZAMAK 5	01	04
	Pin	Steel zinc plated		

** possible to order polyamide pin.

How to order:
 Catalogue number — 3.530.001 — C
 Finish —

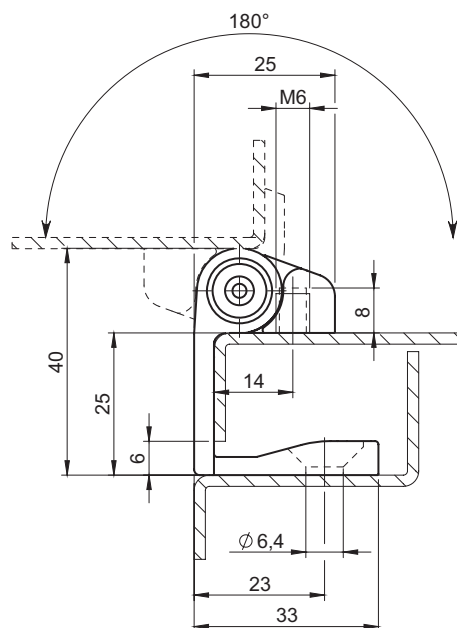
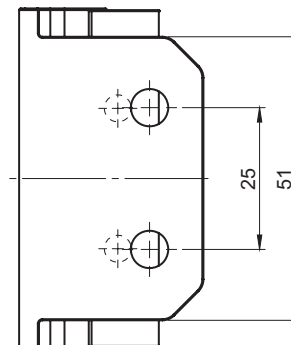
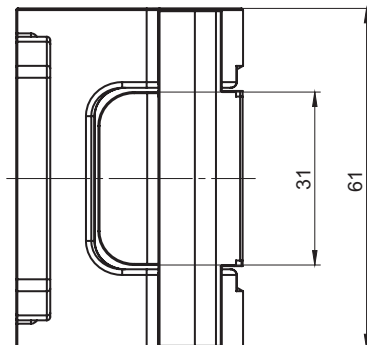

CATALOGUE NUMBER	COMPONENTS	MATERIAL	FINISH [C]	
			Chrome	RAL 9005
3.530.002	Holder, Base	ZAMAK	01	04
	Pin	Polyamide	-	-

How to order:

Catalogue number
Finish [C]



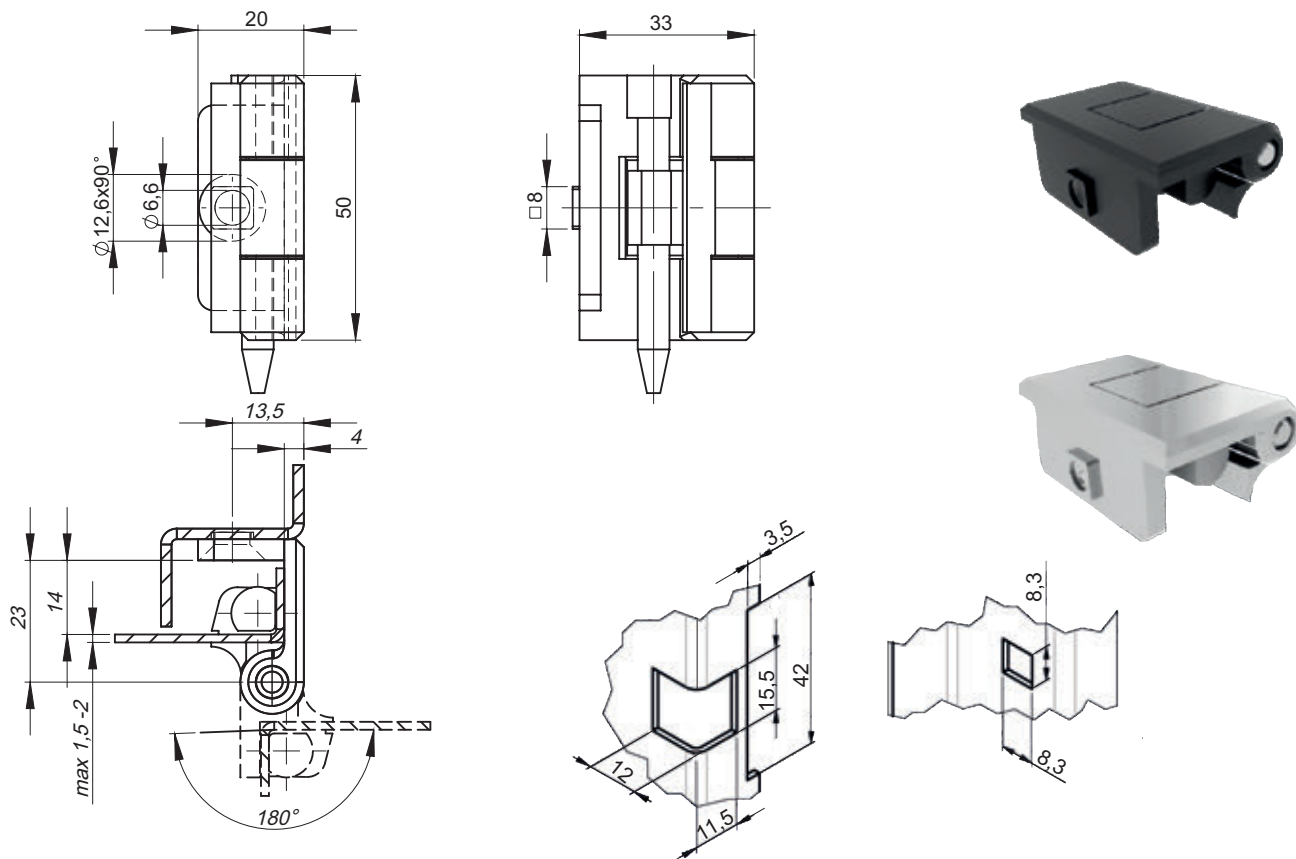

CATALOGUE NUMBER	COMPONENTS	MATERIAL	FINISH [C]	
			Chrome	RAL 9005
3.532.001*	Holder, Base	ZAMAK 5	01	04
	Pin	Steel zinc plated		

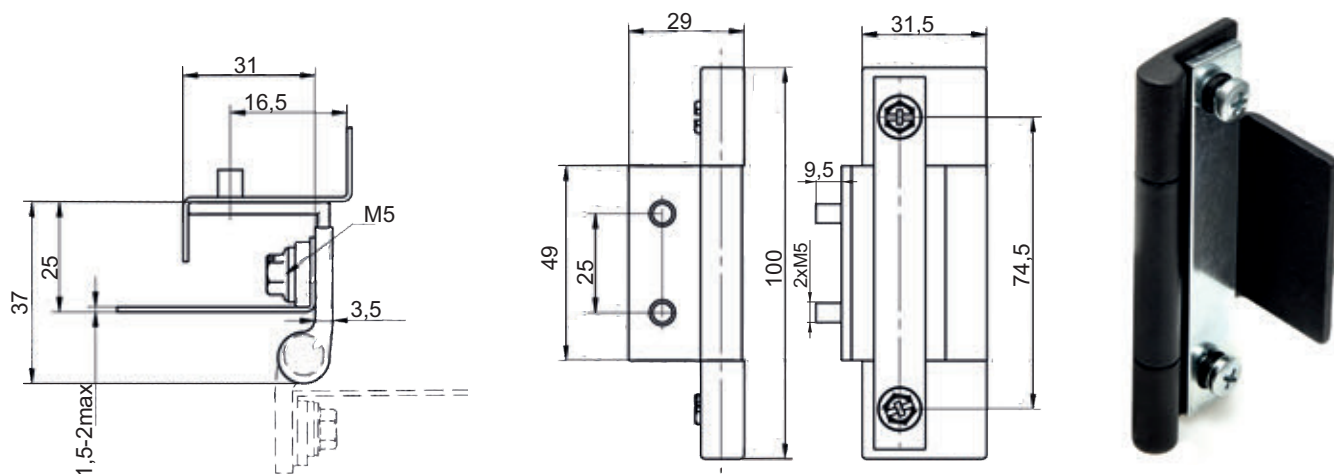

CATALOGUE NUMBER	COMPONENTS	MATERIAL	FINISH [C]	
			Chrome	RAL 9005
3.536.001	Holder	ZAMAK 5	01	04
	Base	Steel zinc plated		

* possibility to order with polyamide pin

How to order:
 Catalogue number 3.532.001
 Finish C



3.ZN120.001

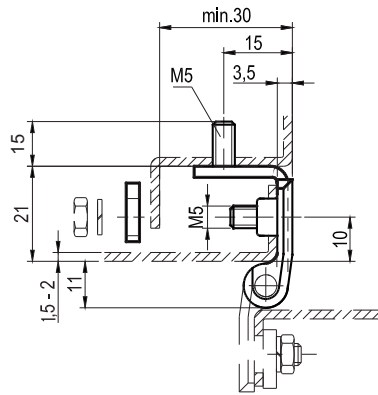

3.ZN120.002

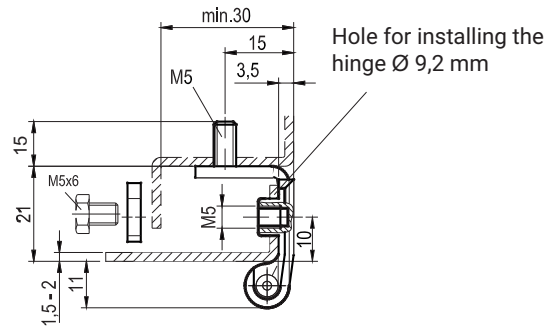

3.ZN120.005

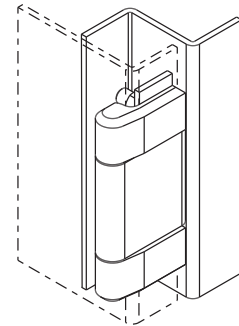
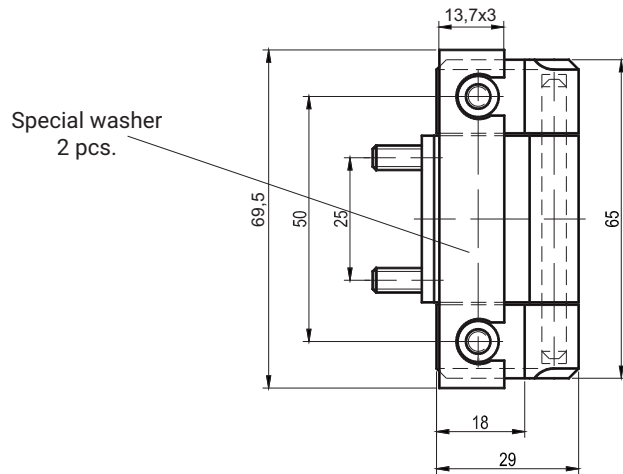
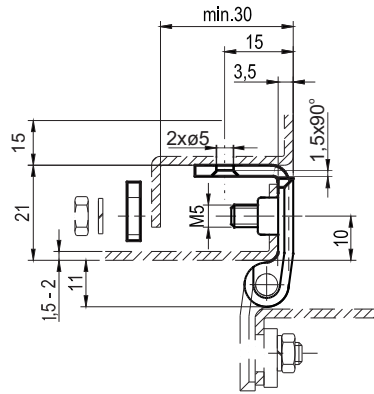

Note:
When using the hinge to sheet a thickness of 1 mm, should order special washer having a thickness of 1 mm

CAT. NUMBER	VERSION	COMPONENTS	MATERIAL	FINISH [C]	
				RAL 9005	RAL 7035
3.ZN120.001	Stud M5	Holder	ZAMAK 5		
3.ZN120.002	Hole M5	Pin, Base	Steel zinc plated	04	05
3.ZN120.005	Hole M5	Pin, Base	Steel zinc plated		

When ordering, specify the color or finishing type

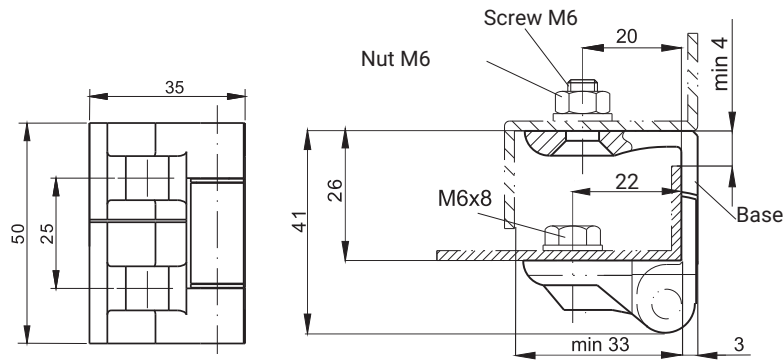

CATALOGUE NUMBER	COMPONENTS	MATERIAL	FINISH [C]	
			RAL 9005	RAL 7035
3.ZN130.001	Holder	ZAMAK 5	04	05
	Base	ZAMAK 5		
	Pin	Steel zinc plated		

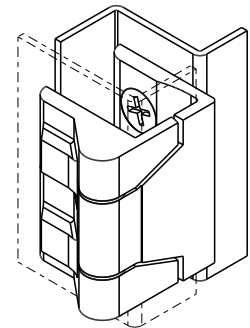
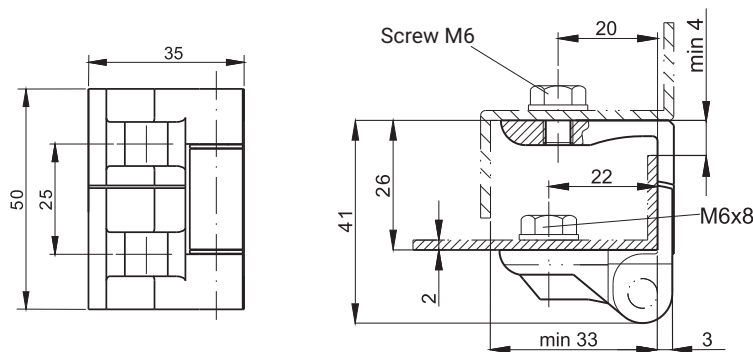

CATALOGUE NUMBER	COMPONENTS	MATERIAL	FINISH [C]	
			RAL 9005	RAL 7035
3.ZN130.002/M6	Holder	ZAMAK 5	04	05
	Base	ZAMAK 5		
	Pin	Steel zinc plated		

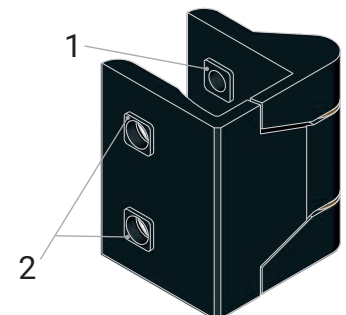
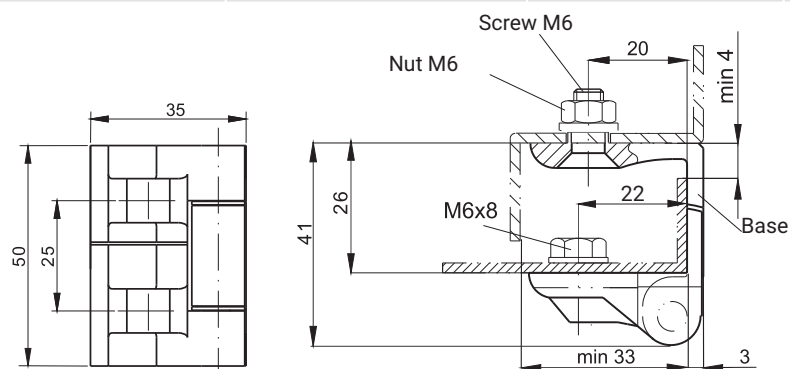

1. Holder with shoulder □ 8x1mm in standard version
2. Base with shoulder □ 8x1mm in version 3.ZN130.003

CATALOGUE NUMBER	COMPONENTS	MATERIAL	FINISH [C]	
			RAL 9005	RAL 7035
3.ZN130.003	Holder	ZAMAK 5	04	05
	Base	ZAMAK 5		
	Pin	Steel zinc plated		

How to order:

Catalogue number 3.ZN130.001 — C
 Finish _____

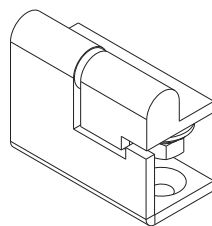
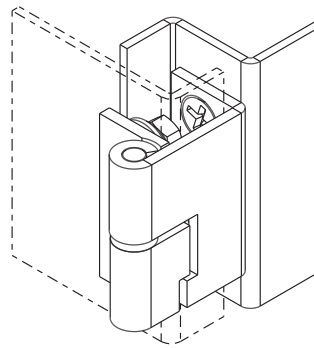
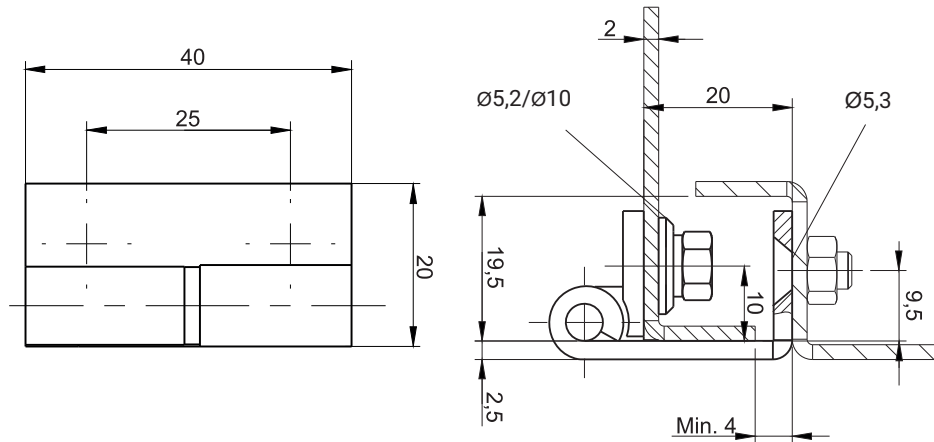

3.ZN140.001
RIGHT VERSION

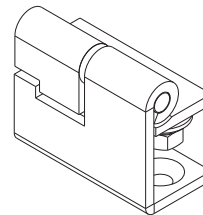

3.ZN140.002
LEFT VERSION

CATALOGUE NUMBER	COMPONENTS	MATERIAL	FINISH [C]	
			RAL 9005	RAL 7035
3.ZN140.001	Holder	Brass	04	05
	Base	Steel zinc plated		
	Pin	Steel zinc plated		
3.ZN140.001SN	Holder, Base, Pin	Stainless steel	-	-
3.ZN140.002	Holder	Brass	04	05
	Base	Steel zinc plated		
	Pin	Steel zinc plated		
3.ZN140.002SN	Holder, Base, Pin	Stainless steel	-	-

How to order:

Catalogue number
Finish

3.ZN140.001 — C

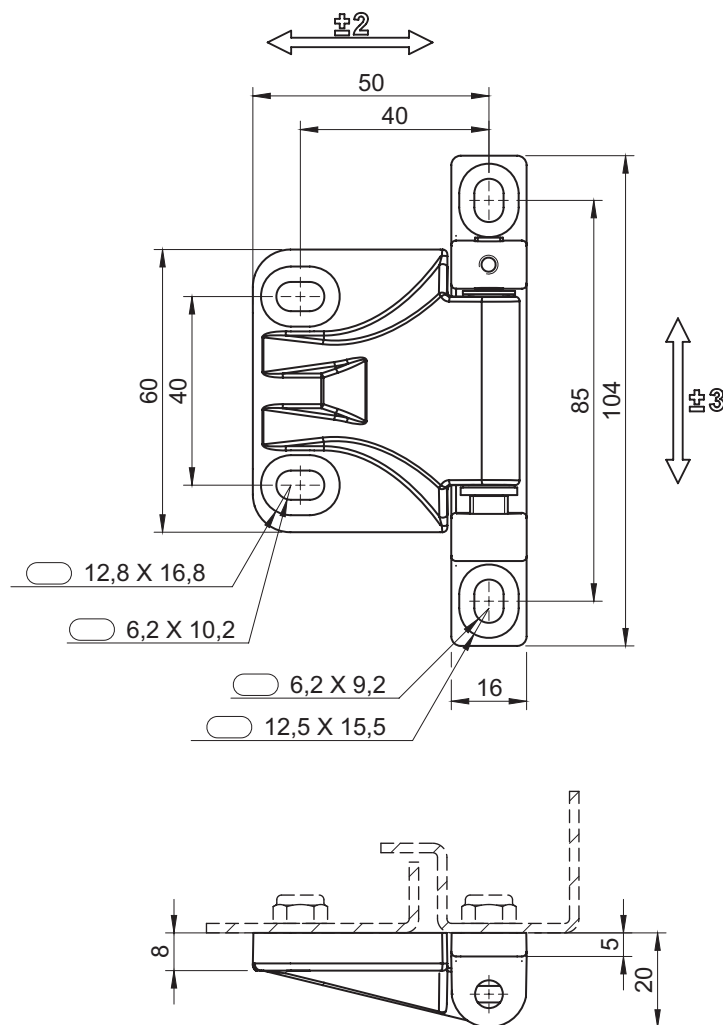

CATALOGUE NUMBER	COMPONENTS	MATERIAL	FINISH [C]
			RAL 9005
3.ZN210.003	Holder, Base	ZAMAK	04
	Pin	Stainless steel	-

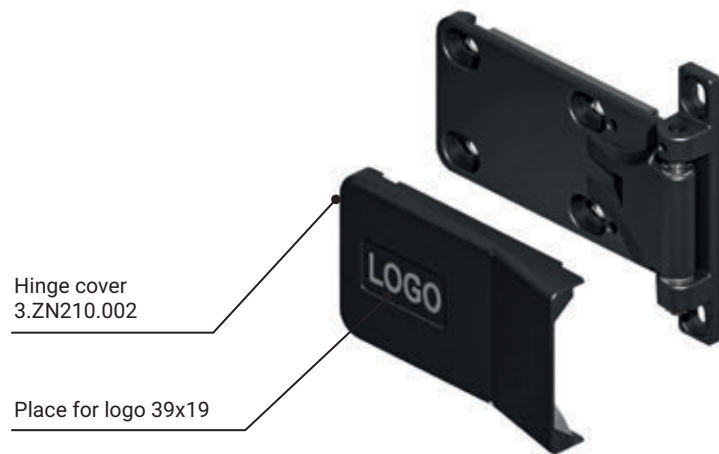
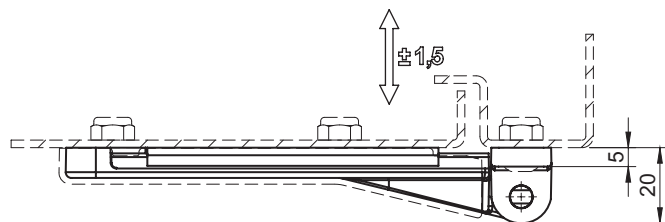
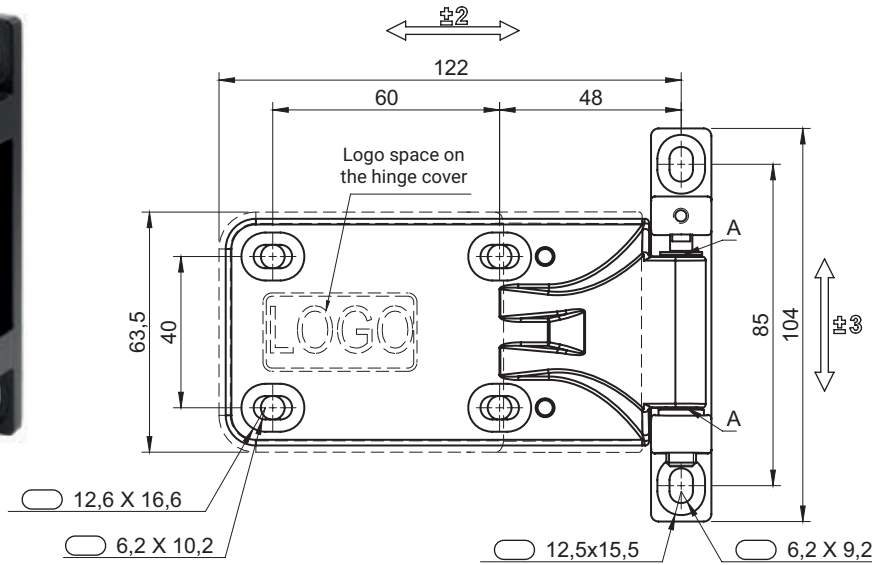

A - axis of the hinge with plastic sleeves.

The hinge position can be adjusted in three axes - the adjustment ranges are shown in the drawing.

Hinge cover 3.ZN210.002 to be ordered separately.

CATALOGUE NUMBER	COMPONENTS	MATERIAL	FINISH [C]
			RAL 9005
3.ZN210.001	Holder, Base	ZAMAK	04
	Pin	Stainless steel	-
3.ZN210.002	Hinge cover	Polyamide	07

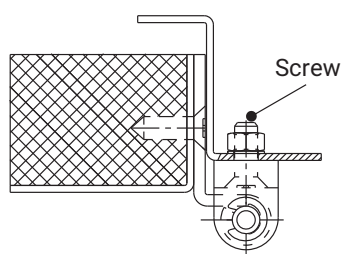
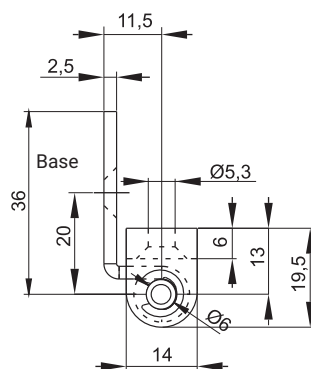
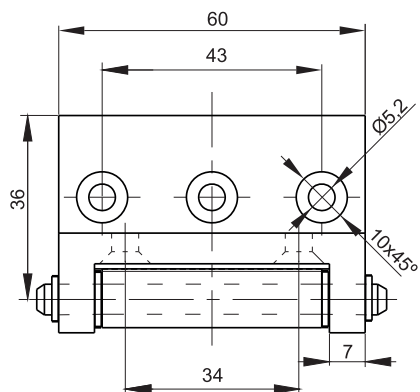

CATALOGUE NUMBER	COMPONENTS	MATERIAL
3.ST42.001	Holder	Steel zinc plated
	Base	ZAMAK 5
	Pin	Steel zinc plated

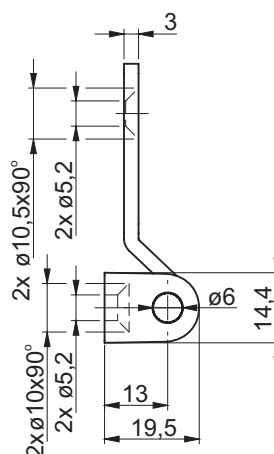
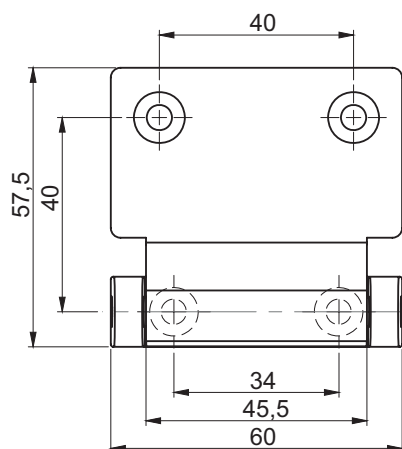

Note:

The hinge supplied as separate parts, handle with foot joint by pushing the pin after mounting the handle.

CATALOGUE NUMBER	COMPONENTS	MATERIAL	FINISH [C]
			RAL 9005
3.ST42.005	Holder	Steel zinc plated	04
	Base	ZAMAK5	
	Pin	Stainless steel	
3.ST42.005SN	Holder	Stainless steel	04
	Base	ZAMAK5	
	Pin	Stainless steel	

How to order:

Catalogue number
Finish

3.ST42.005 — C

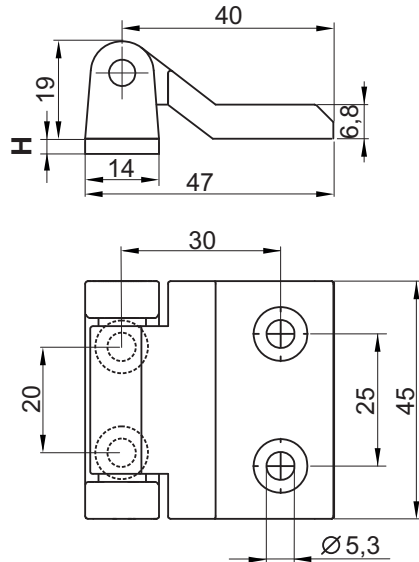

CATALOGUE NUMBER	COMPONENTS	MATERIAL	FINISH [C]	
			Chrome	RAL9005
3.514.C.X	Holder, Base	ZAMAK5	01	04
	Pin	Steel zinc plated	-	-

How to order :
Hinge code
Finish
Height H

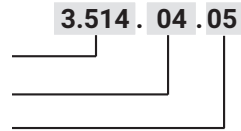

H [mm]	0	3	5	8	10	15
X	00	03	05	08	10	15

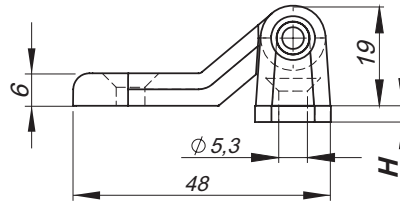

Height H
adjusted
by distance
rings

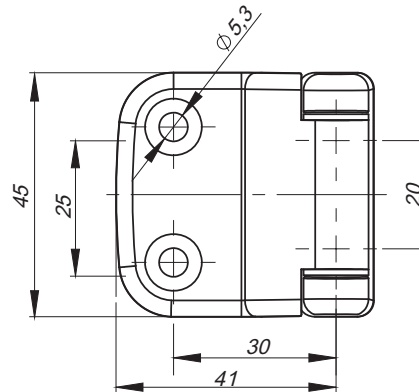

CATALOGUE NUMBER	COMPONENTS	MATERIAL	FINISH [C]	
			Chrome	RAL9005
3.519.C.X	Holder, Base	ZAMAK5	01	04
	Pin	Stainless steel	-	-
	Sleeve	POM	-	-

How to order :
Hinge code
Finish
Height H

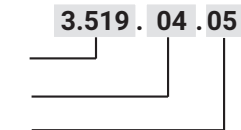

H [mm]	0	3	5	8	10	15
X	00	03	05	08	10	15

3.531.001

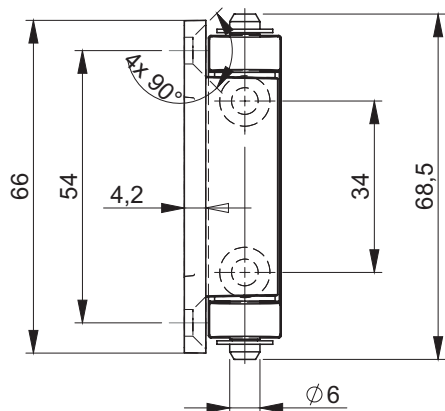

Insert fastening
Collecting plate

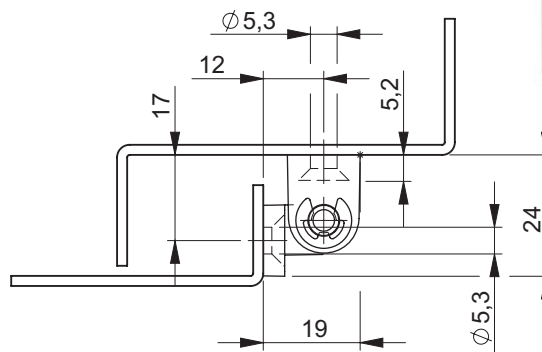

3.531.002

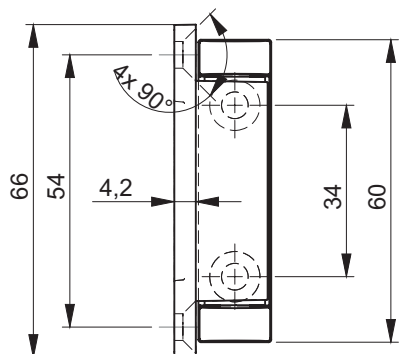

Insert fastening
Knurled

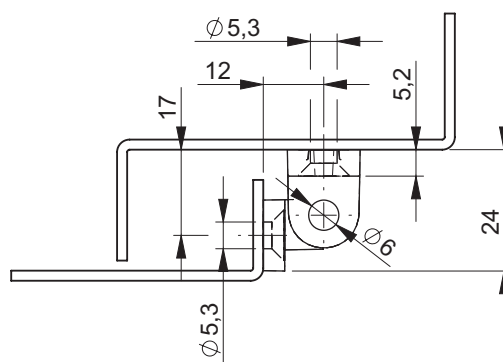

CATALOGUE NUMBER	COMPONENTS	MATERIAL	FINISH [C]	
			Chrome	RAL9005
3.531.001	Holder, Base	ZAMAK 5	01	04
3.531.002	Pin	Steel zinc plated		

How to order:

Catalogue number

Finish

3.531.001 — C

stainless steel

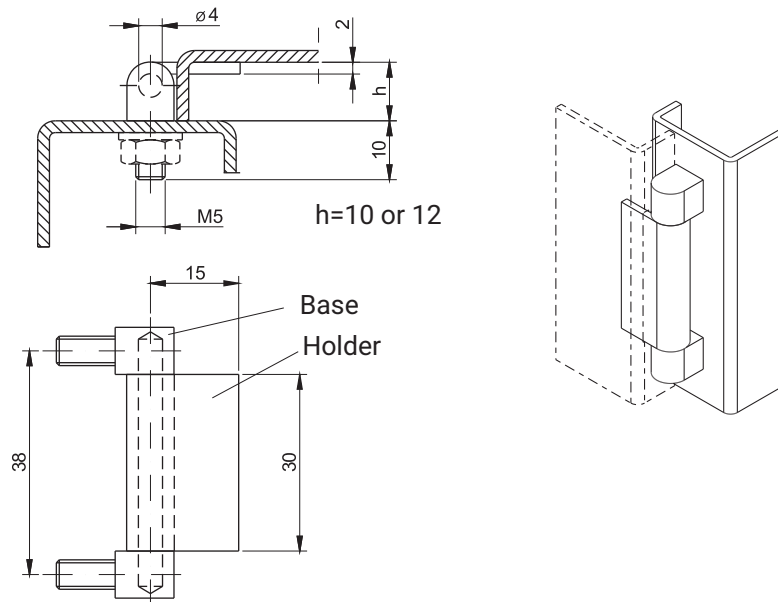

CATALOGUE NUMBER	COMPONENTS	MATERIAL
3.ST23.001	Holder	Steel zinc plated
	Base, Pin	Steel zinc plated
3.ST23.001SN	Holder	Stainless steel
	Base, Pin	Stainless steel

x

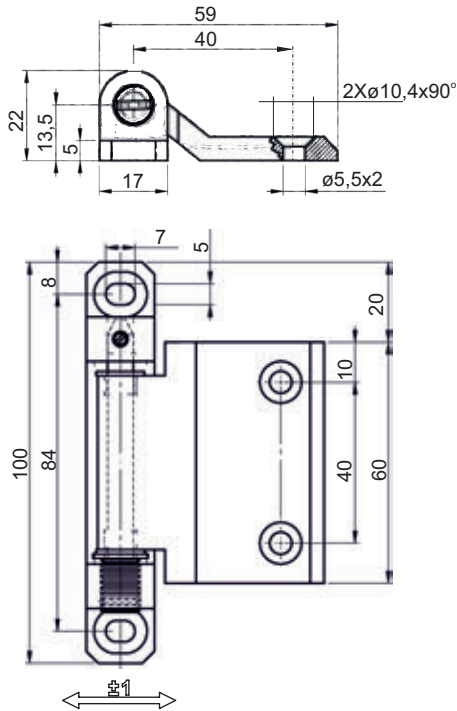

CATALOGUE NUMBER	COMPONENTS	MATERIAL	FINISH [C]	
			Chrome	RAL 9005
3.535.001	Holder	ZAMAK 5	01	04
	Base	ZAMAK 5		

How to order:

Catalogue number

Finish

3.535.001 — C

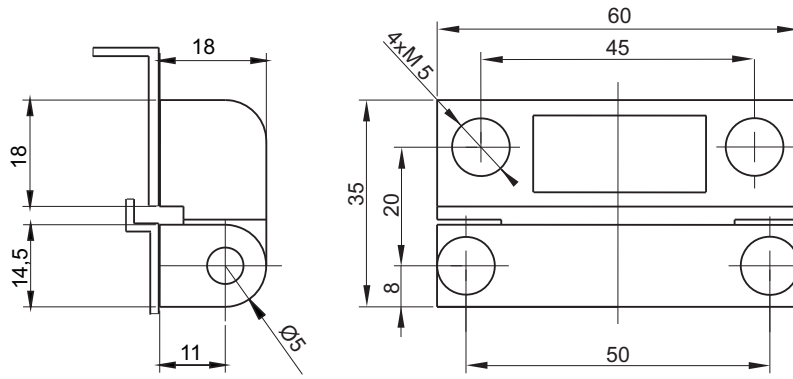

CATALOGUE NUMBER	COMPONENTS	MATERIAL	FINISH [C]	
			Nickel	RAL9005
3.517.001	Holder, Base	ZAMAK 5	02	04
	Pin	Steel zinc plated	-	-

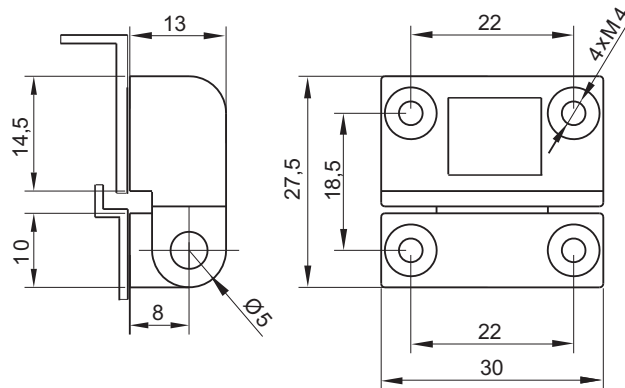

CATALOGUE NUMBER	COMPONENTS	MATERIAL	FINISH [C]	
			Nickel	RAL9005
3.517.002	Holder, Base	ZAMAK 5	02	04
	Pin	Steel zinc plated	-	-

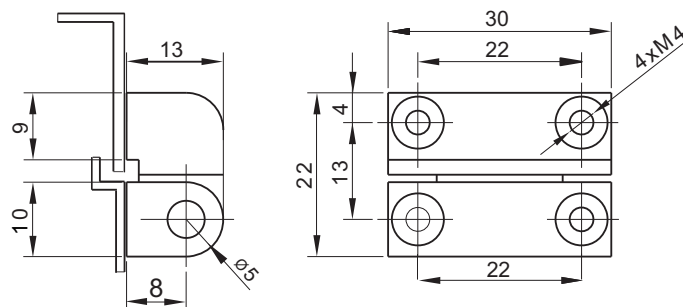

CATALOGUE NUMBER	COMPONENTS	MATERIAL	FINISH [C]	
			Nickel	RAL9005
3.517.003	Holder, Base	ZAMAK 5	02	04
	Pin	Steel zinc plated	-	-

How to order:

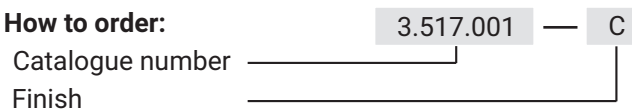

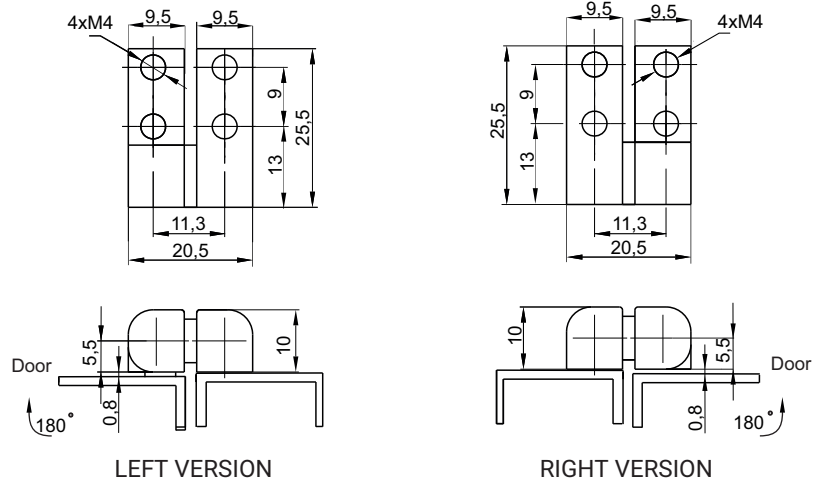

CATALOGUE NUMBER	COMPONENTS	MATERIAL	FINISH [C]
			RAL 9005
3.518.001	Holder, Base	ZAMAK 5	04
	Pin	Steel zinc plated	

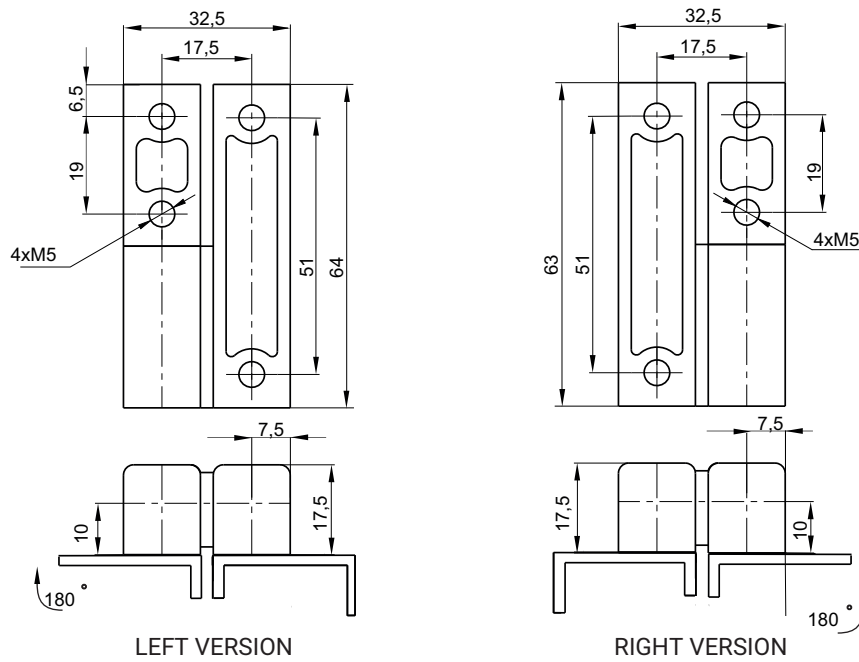

CATALOGUE NUMBER	COMPONENTS	MATERIAL	FINISH [C]
			RAL 9005
3.518.002	Holder, Base	ZAMAK 5	04
	Pin	Steel zinc plated	

How to order:

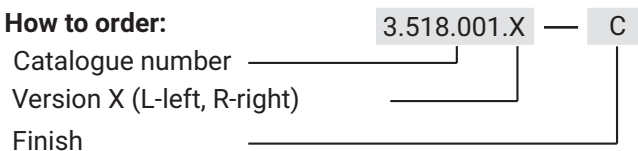

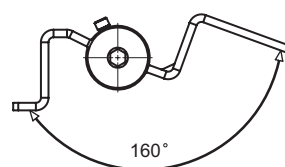
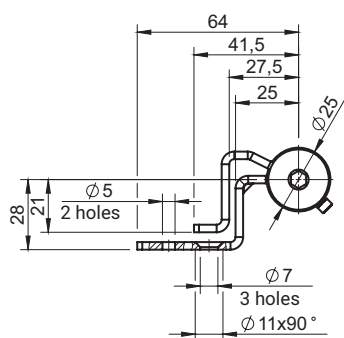
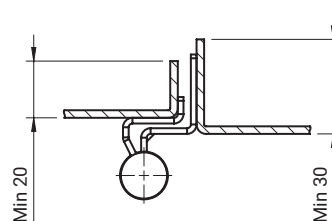
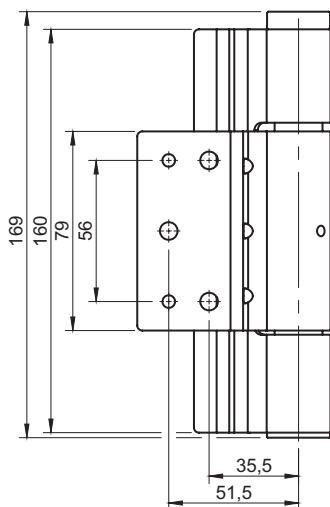

Closed position

Open position

CATALOGUE NUMBER	VERSION	COMPONENTS	MATERIAL
3.ST109.001-A	Spring hinge	Holder, Base, Pin	Steel zinc plated
3.ST109.001-B	KO hinge		

where:

3.ST109.001-A - spring hinge causing self-locking

3.ST109.001-B - support hinge - without spring

3.ST109.003-A Right version

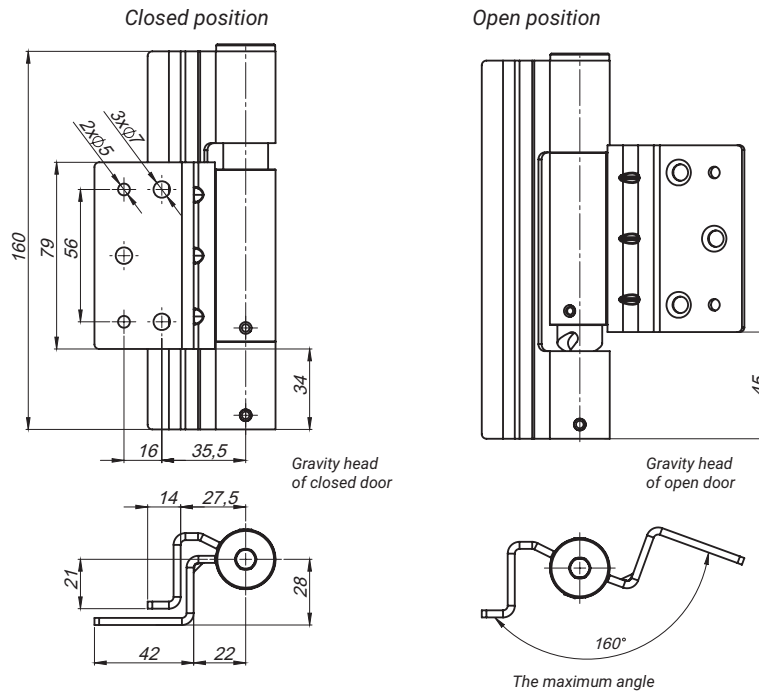

CATALOGUE NUMBER	VERSION	COMPONENTS	MATERIAL
3.ST109.003-A	Right	Handle, base	Steel zinc plated
3.ST109.003-B	Left		

Bearing hinge causes automatic door closure and lifting the door while opening.
The set of hinges is **3.ST109.003 + 3.ST109.004** or two hinges **3.ST109.003**
Left version is the mirror image of the right version.

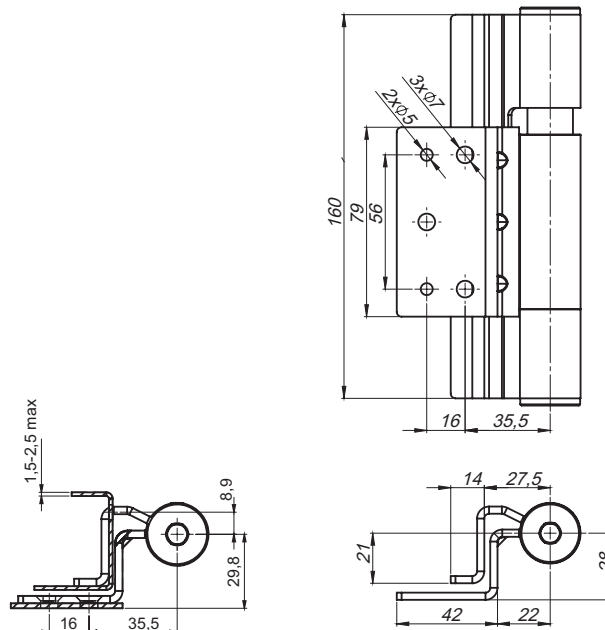

CATALOGUE NUMBER	COMPONENTS	MATERIAL
3.ST109.004	Handle, base	Steel zinc plated

The positioning hinge in door axis cooperates only with the hinge **3.ST109.003**

Fire door hinges with hight regulation on thread

3.ST109.007-B

Left version

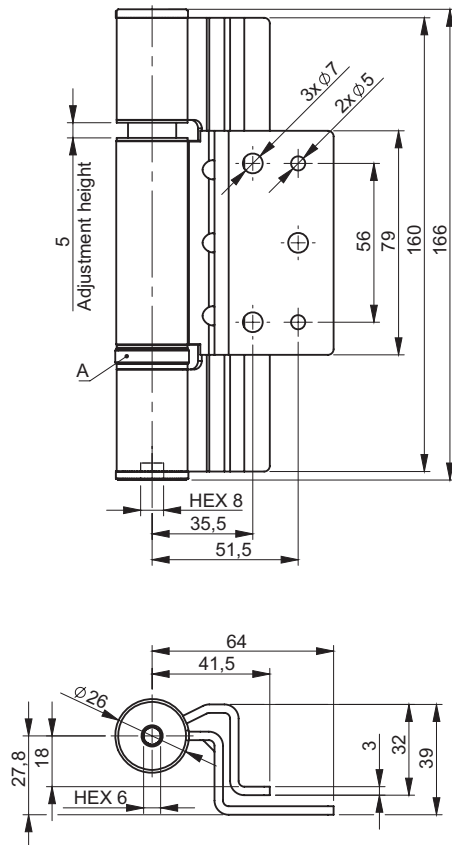

3.ST109.007-A

Right version

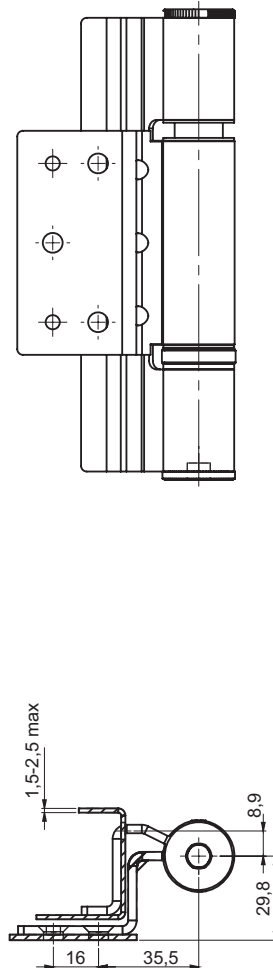

CATALOGUE NUMBER	VERSION	COMPONENTS	MATERIAL
3.ST109.007-A	Right	Holder, Base, Pin	Steel zinc plated
3.ST109.007-B	Left		

A - thrust bearing

Max. load: 80kg

Hinge welded to door frame and screwed into a door

Hinge 3.ST109.007 is compatible with spring hinge 3.ST109.001-A



3.ST109.100

3.ST109.100

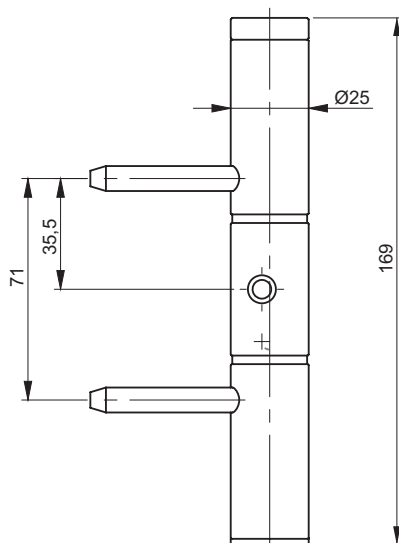

3.ST109.101

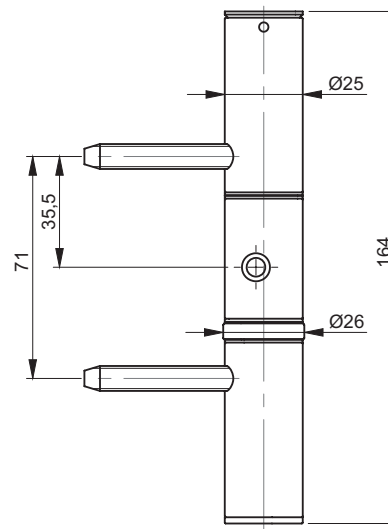

3.ST109.101

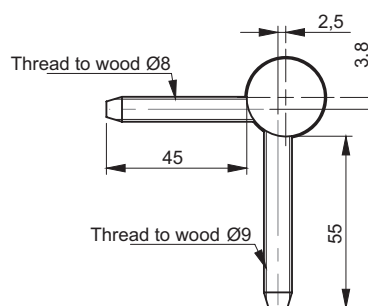
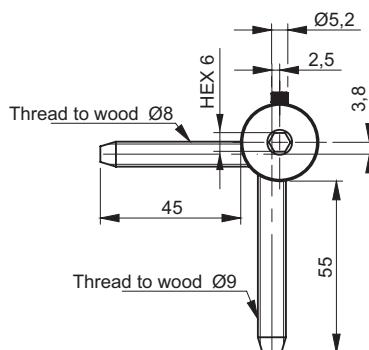

CATALOGUE NUMBER	DETAIL	COMPONENTS	MATERIAL
3.ST109.100	Spring hinge	Holder, Base	Steel zinc plated
3.ST109.101	KO hinge		

Fire door hinges with height regulation

3.ST109.009-B

Left version

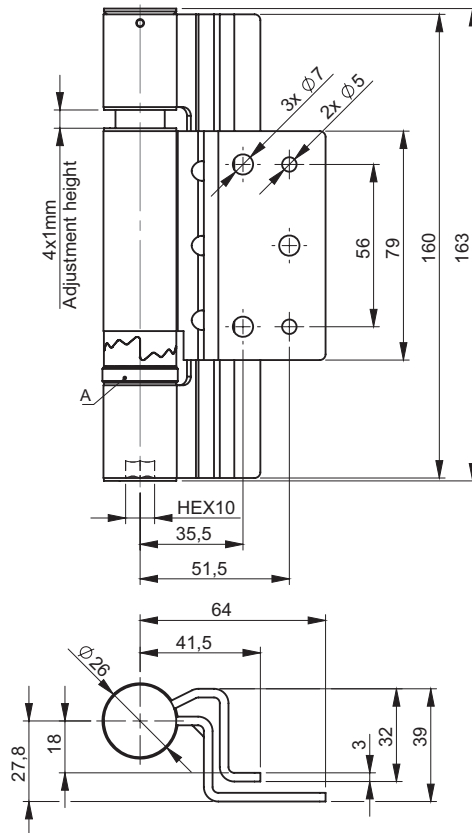

3.ST109.009-A

Right version

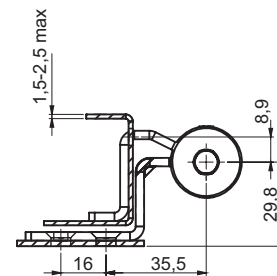
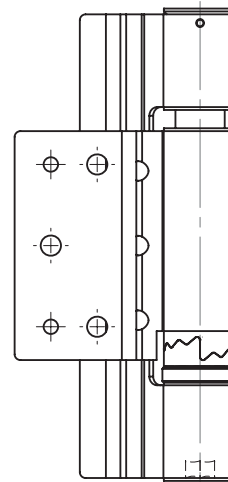

CATALOGUE NUMBER	VERSION	COMPONENTS	MATERIAL
3.ST109.009-A	Right	Holder, Base, Pin	Steel zinc plated
3.ST109.009-B	Left		

A - thrust bearing

Max. load: 80kg

Hinge welded to door frame and screwed into a door

4-stage height adjustment, each stage lifts or lowers the door of 1mm

Hinge 3.ST109.009 is compatible with spring hinge 3.ST109.001-A



3.ST125.001

Right version - open position

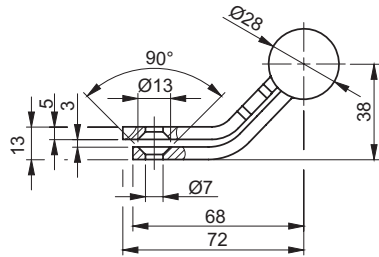

Left version - open position

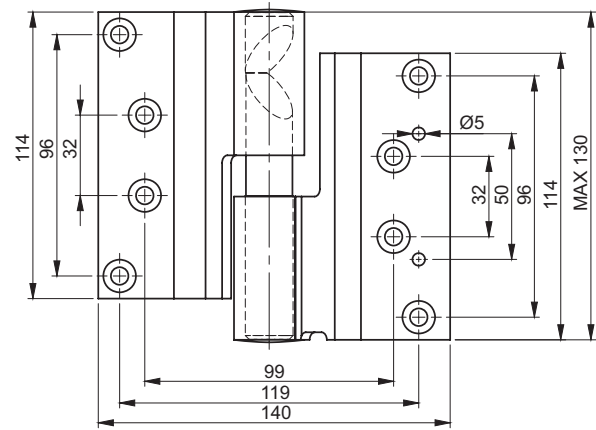
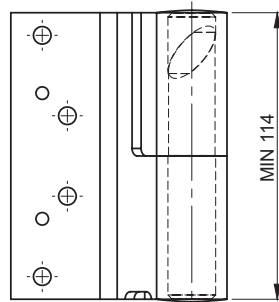
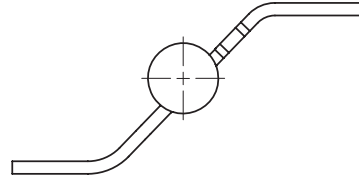

3.ST125.002

Right version - closed position

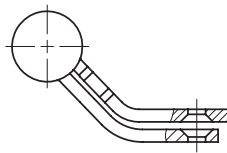

Right version - open position

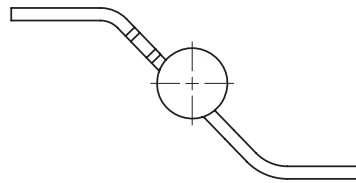

CAT. NUMBER	VERSION	COMPONENTS	MATERIAL	FINISH [C]
				Chrome
3.ST125.001	Left	Door, Insert	Carbon steel	01
3.ST125.002	Right			

Left version is the mirror image of the right version

How to order:

Catalogue number

Finish

3.ST125.001 — C

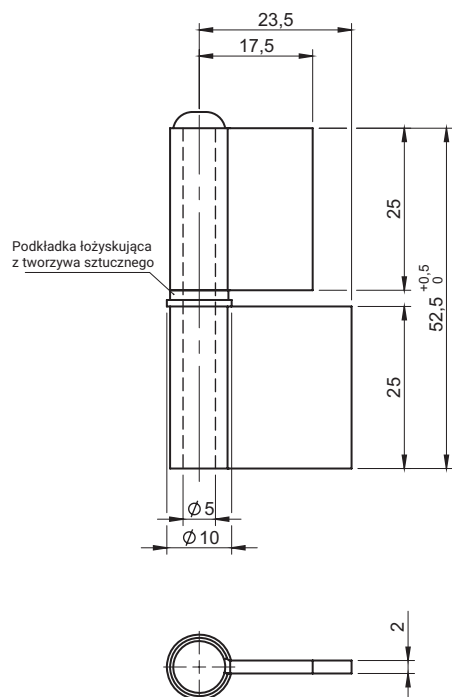

CATALOGUE NUMBER	COMPONENTS	MATERIAL
3.ST127.001SN	Holder, Base, Pin	Stainless steel

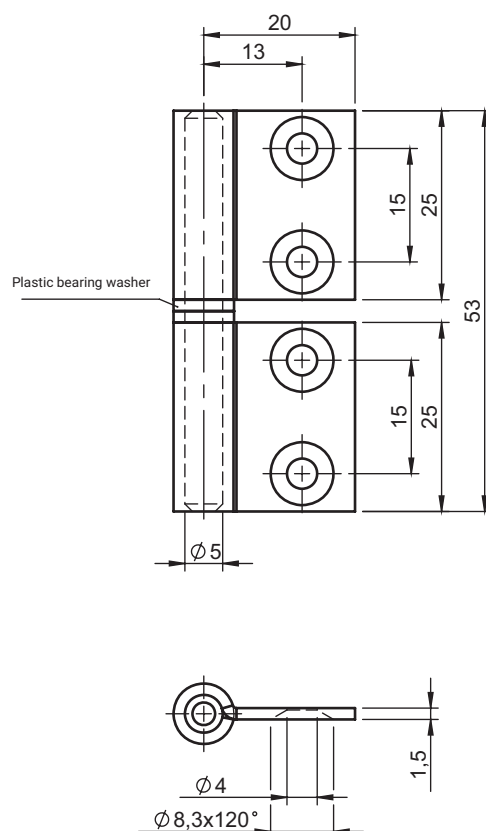

Hinge pin welded into one of the wings during final assembly.
Hinge supplied in a sets of parts.

CATALOGUE NUMBER	COMPONENTS	MATERIAL
3.ST127.002SN	Holder, Base, Pin	Stainless steel



LEFT HINGE



RIGHT HINGE

LEFT HINGE
3.ST127.003SN - B

RIGHT HINGE
3.ST127.003SN - A

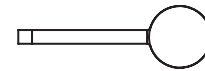
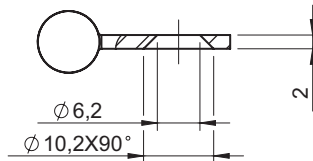
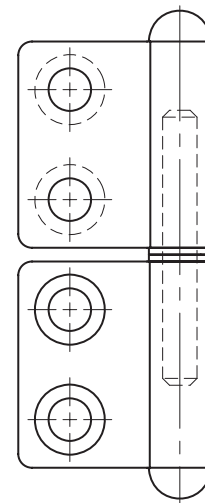
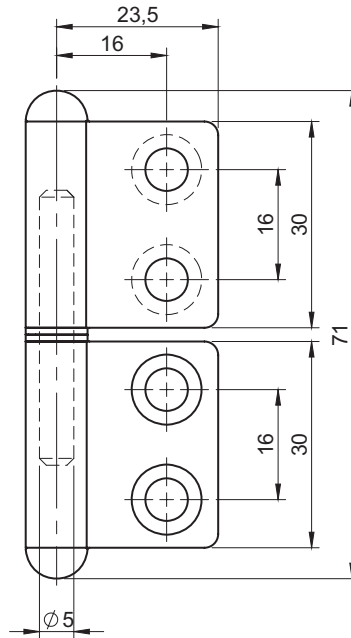

CATALOGUE NUMBER	VERSION	COMPONENTS	MATERIAL
3.ST127.003SN-A	Right	Holder, Base, Pin	Stainless steel
3.ST127.003SN-B	Left		



3.ST30.001
3.ST30.001SN

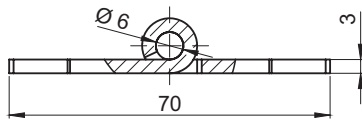

3.ST30.005

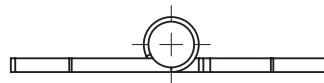

3.ST30.008
3.ST30.010

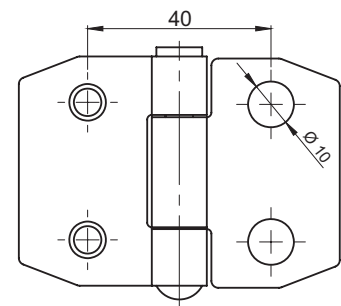
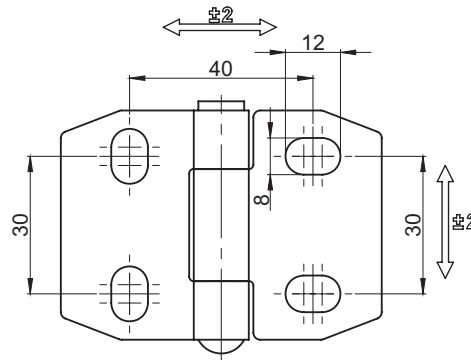
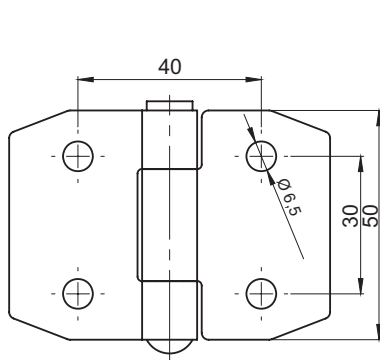
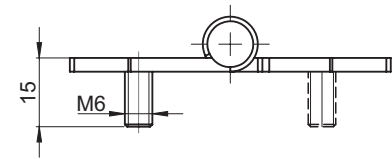

CATALOGUE NUMBER	VERSION	COMPONENTS	MATERIAL
3.ST30.001	4x Ø 6,5	Holder, Base	Steel zinc plated
		Pin	Stainless steel
3.ST30.001SN		Holder, Base, Pin	Stainless steel
3.ST30.005	4x 8x12	Holder, Base	Steel zinc plated
		Pin	Stainless steel
3.ST30.008	2x M6x15 2x Ø 10	Holder, Base	Steel zinc plated
		Pin	Stainless steel
3.ST30.010	4x M6x15	Holder, Base	Steel zinc plated
		Pin	Stainless steel

stainless steel

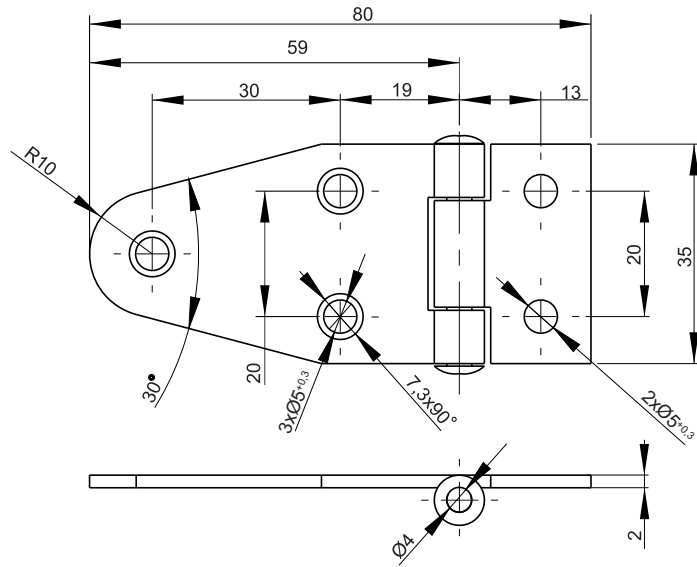

CATALOGUE NUMBER	COMPONENTS	MATERIAL
3.ST35-1.001	Holder, Base, Pin	Steel zinc plated
3.ST35-1.001SN	Holder, Base, Pin	Stainless steel

stainless steel

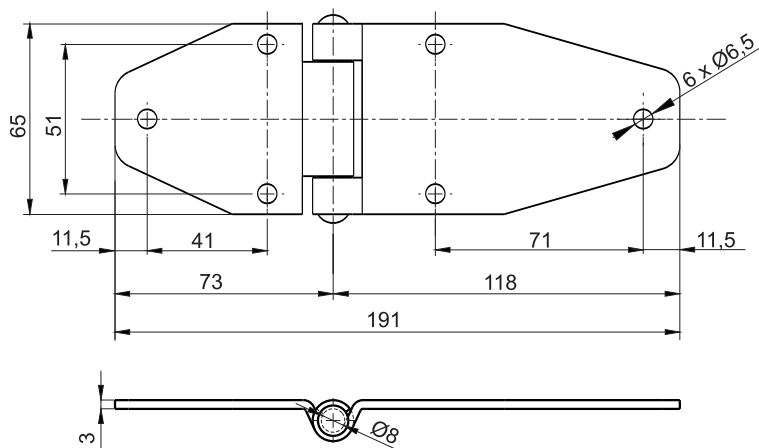

CATALOGUE NUMBER	COMPONENTS	MATERIAL
3.ST35.001	Holder, Base, Pin	Steel zinc plated
3.ST35.001SN	Holder, Base, Pin	Stainless steel

stainless steel

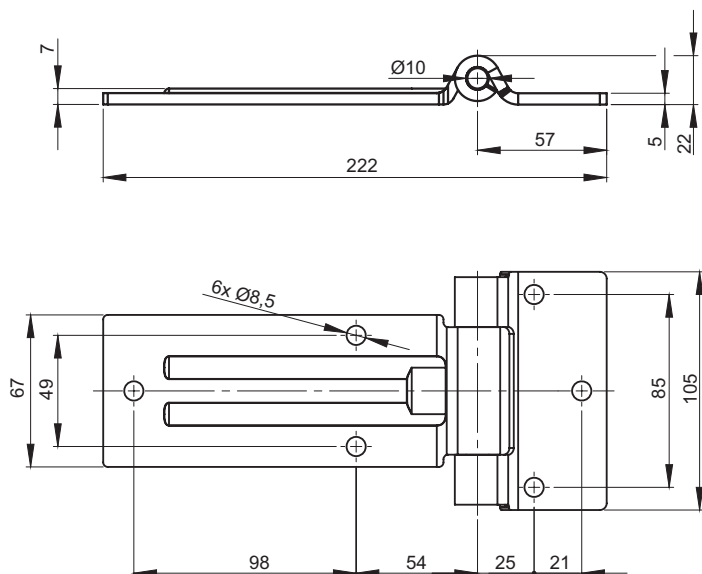

CATALOGUE NUMBER	COMPONENTS	MATERIAL
3.ST133.001	Holder, Base, Pin	Stainless steel polished

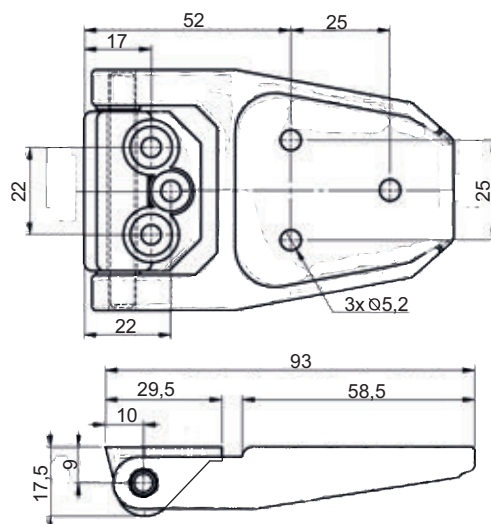

CATALOGUE NUMBER	COMPONENTS	MATERIAL	FINISH [C]
			RAL 9005
3.534.001	Holder, Base	Polyamide	07
	Pin	Polyamide	

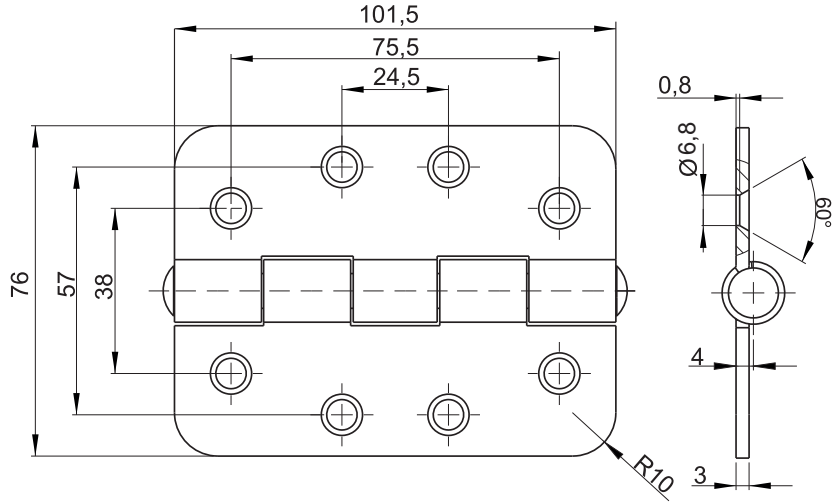

CATALOGUE NUMBER	COMPONENTS	MATERIAL
3.ST35-2.002	Holder, Base	Stainless steel
	Pin	Stainless steel

Hinge available with beveled holes or without.

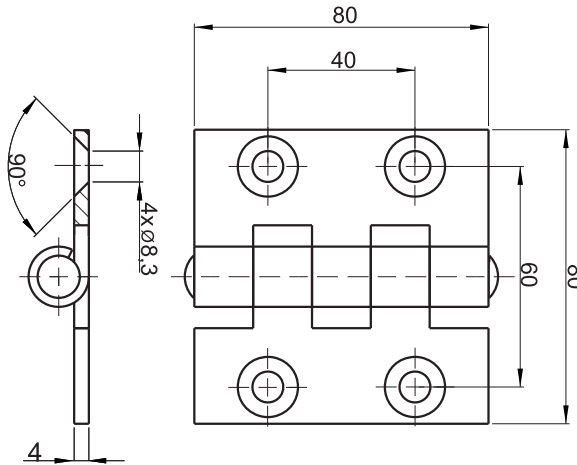

CATALOGUE NUMBER	COMPONENTS	MATERIAL
3.ST58.001	Holder, Base	Steel zinc plated
	Pin	Stainless steel

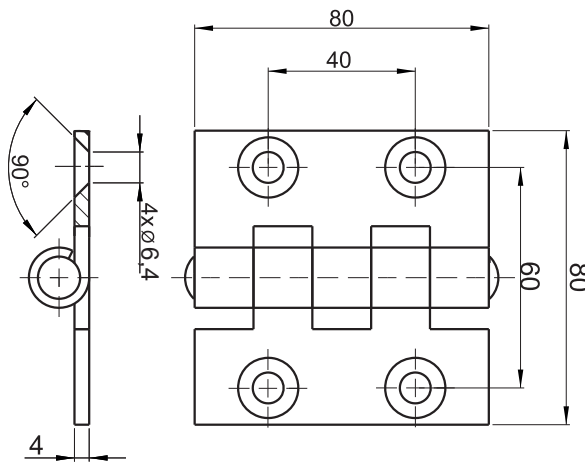

CATALOGUE NUMBER	COMPONENTS	MATERIAL
3.ST58.002	Holder, Base	Steel zinc plated
	Pin	Stainless steel

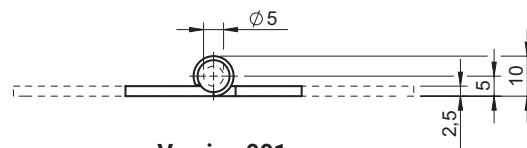

Version 001

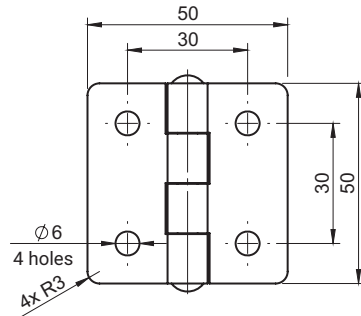

Version 002

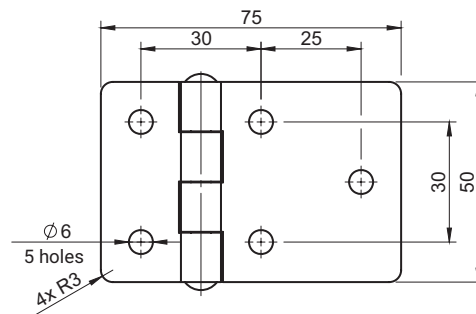

Version 003

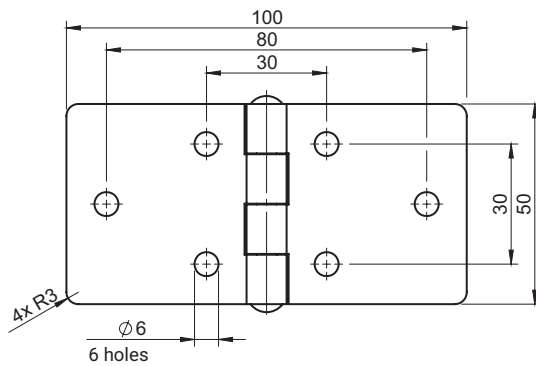

CATALOGUE NUMBER	COMPONENTS	MATERIAL	FINISH [C]		
			No finish	Galvanized	RAL 9005
3.ST114.001 3.ST114.002 3.ST114.003	Holder, Base	Steel	-	01	04
	Pin	Stainless steel	-	-	-
3.ST114.001SN 3.ST114.002SN 3.ST114.003SN	Holder, Base, Pin	Stainless steel	00	-	-

How to order:

Catalogue number
Finish [C]

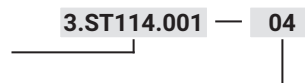

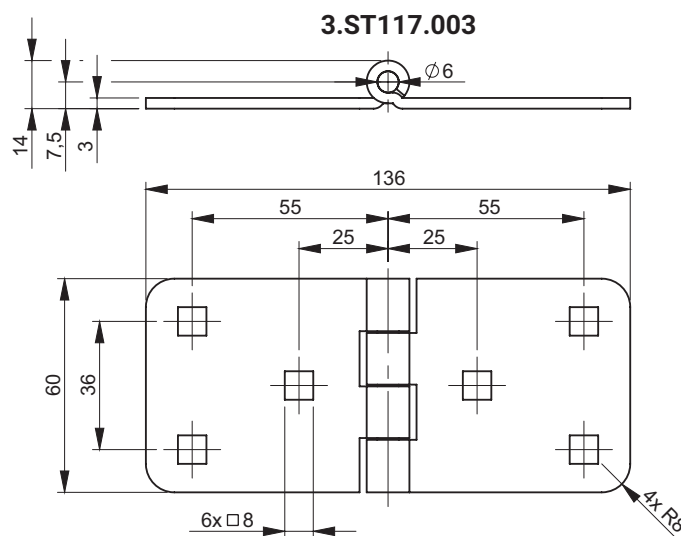
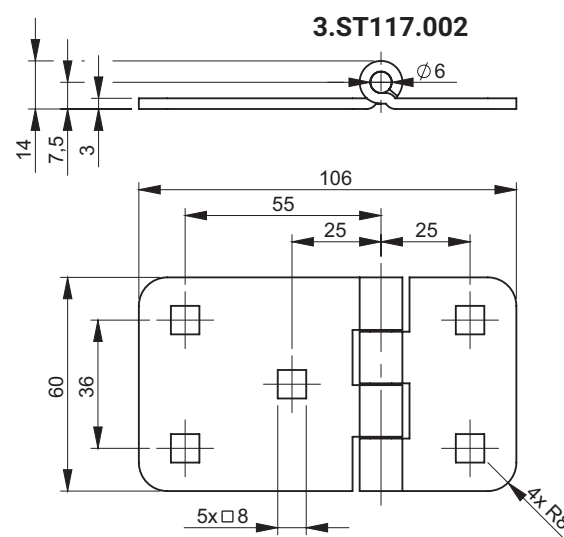
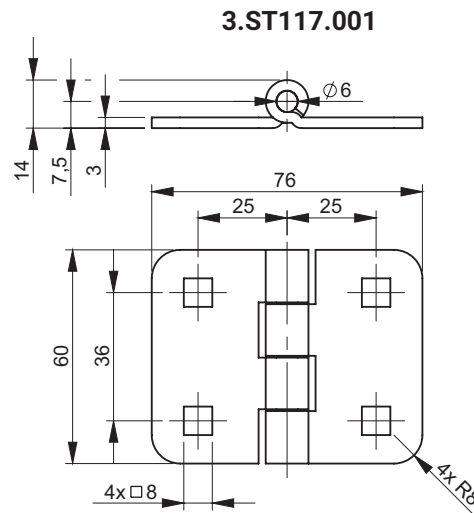

CATALOGUE NUMBER	COMPONENTS	MATERIAL
3.ST117.001 3.ST117.002 3.ST117.003	Holder, Base, DIN603 M8x16	Steel zinc plated
	Pin	Stainless steel

Hinge sold together with set of screws DIN 603 M8x16

Hinge with an opening angle limiter 3.ST145

Hinge 3.ST146



ROZTOCZE

3A

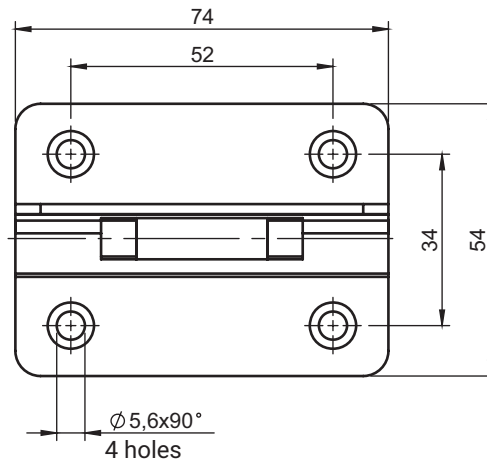
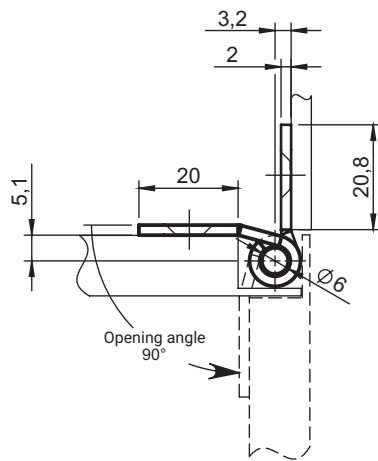

Rotation limiter built into the hinge fold



Hinge with an opening angle limiter up to 90°.

CATALOGUE NUMBER	COMPONENTS	MATERIAL
3.ST145.001SN	Holder, Base, Pin	Stainless steel

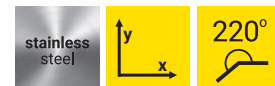
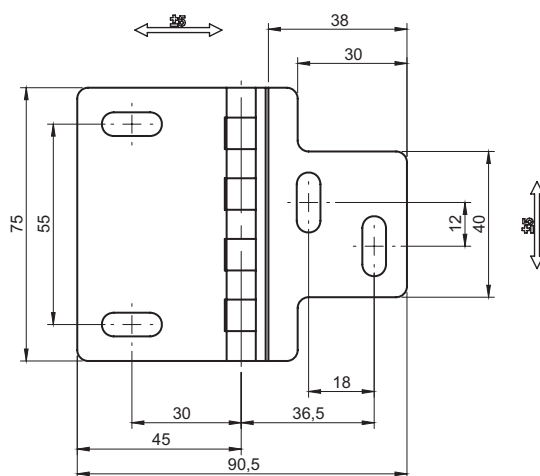
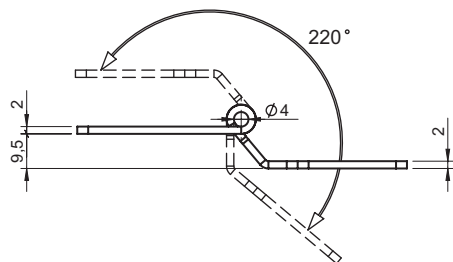

Hinge with two-way position adjustment

CATALOGUE NUMBER	MATERIAL
3.ST146.001SN	Stainless steel



stainless steel

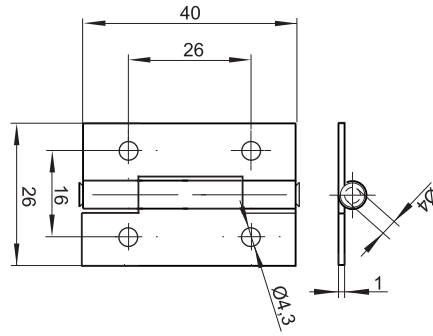

CATALOGUE NUMBER	COMPONENTS	MATERIAL
3.ST37.001	Holder, Base, Pin	Steel zinc plated
3.ST37.001SN	Holder, Base, Pin	Stainless steel



stainless steel

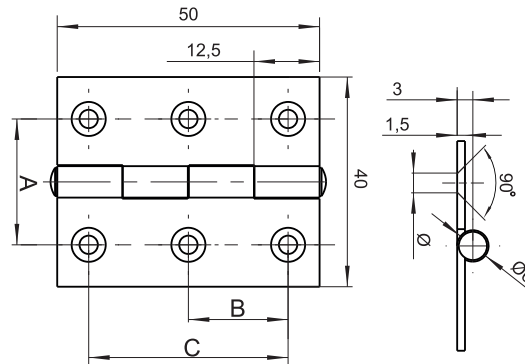

CATALOGUE NO.	X	Ø	A	B	C	where:	
						X - indication of the hinge	* - no chamfer on mounting holes
3.ST48.00X	1	4,7mm	24	19	38		
3.ST48.00X SN	2	5mm	23	17,5	35		
	3*	4mm	23	17,5	35		

CATALOGUE NUMBER	COMPONENTS	MATERIAL	FINISH [C]	
			RAL 9005	RAL 7035
3.ST48.00X	Holder, Base, Pin	Steel zinc plated	04	05
3.ST48.00X SN	Holder, Base, Pin	Stainless steel	-	-

How to order:

Catalogue number _____
Finish _____

3.ST48.00X — C



stainless steel

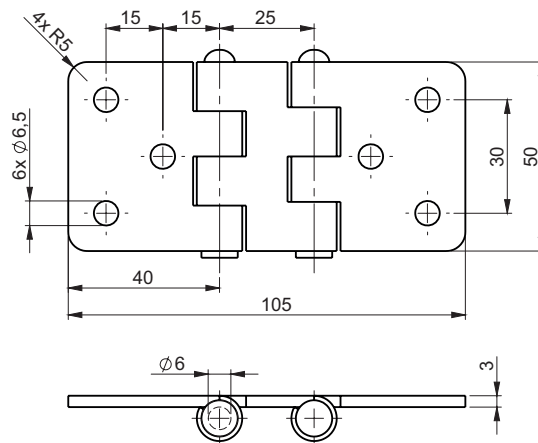

CATALOGUE NUMBER	COMPONENTS	MATERIAL
3.ST55.001	Holder, Base, Pin	Steel zinc plated
3.ST55.001SN	Holder, Base, Pin	Stainless steel

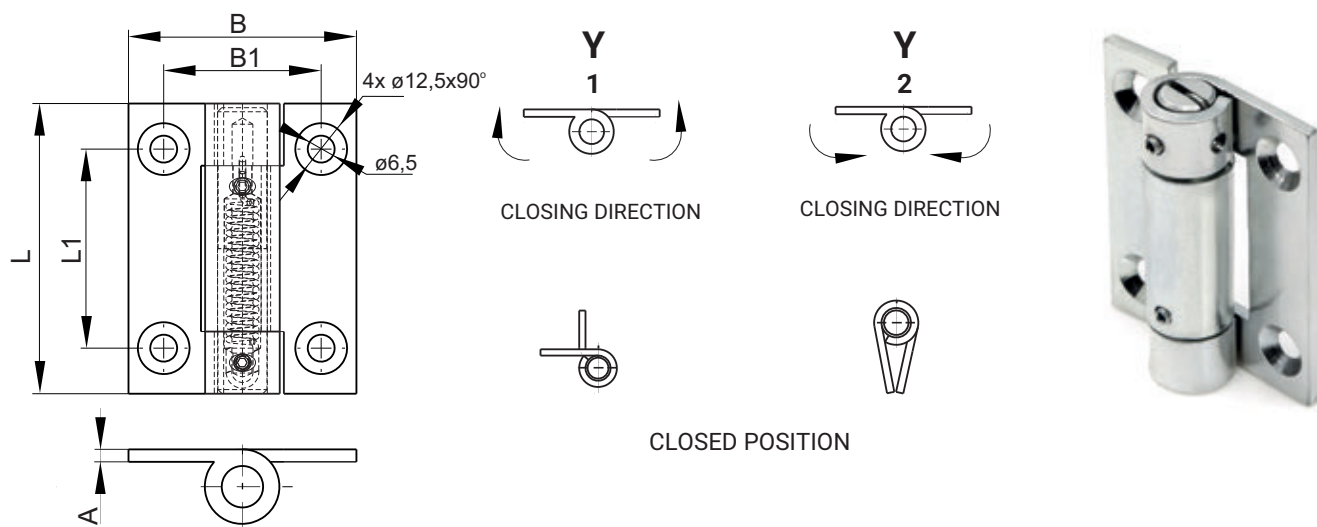

HINGE	X	A	L	L1	B	B1
3.ST108.X0Y	1	3	70	48	55	38
	2	3	80	60	65	45
	3	3	60	36	76	56
CATALOGUE NUMBER	COMPONENTS		MATERIAL			
3.ST108.001	Holder, Base		Steel zinc plated			
	Pin		Steel zinc plated			

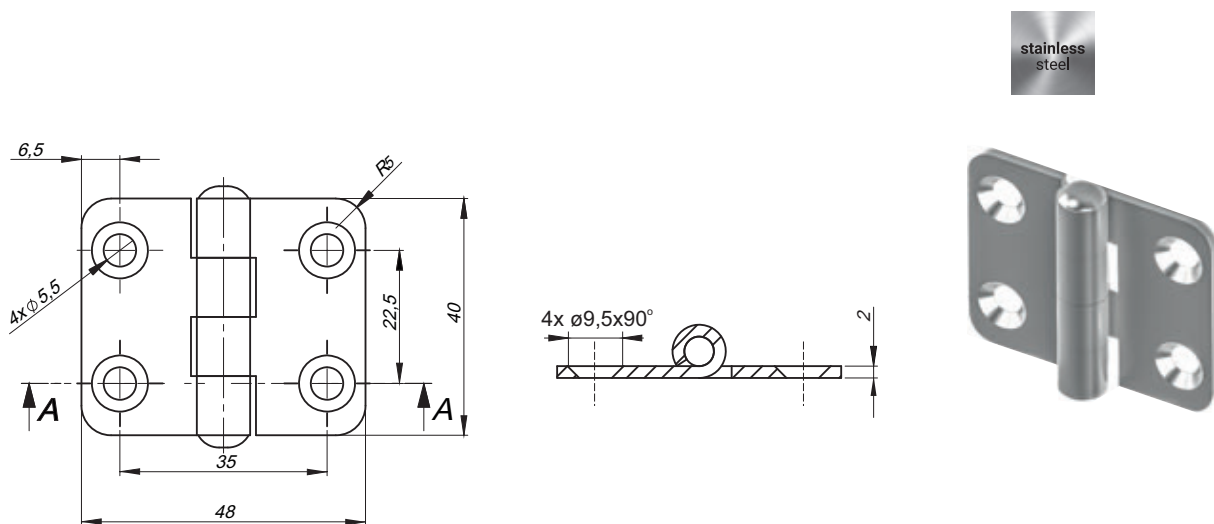

CATALOGUE NUMBER	COMPONENTS	MATERIAL
3.ST28.001	Holder, Base	Stainless steel 1.4301
	Pin	Stainless steel 1.4301

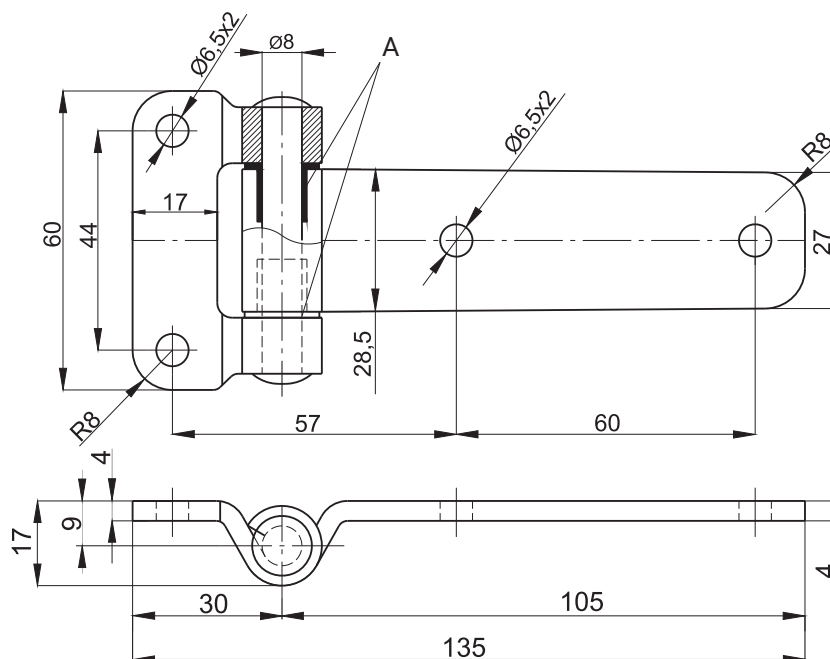

CATALOGUE NUMBER	COMPONENTS	MATERIAL	FINISH [C]
			RAL 9005
3.ST56.002	Holder, Base	Steel zinc plated	04
	Pin	Stainless steel	
3.ST56.002SN	Holder, Base, Pin	Stainless steel	-

A - plastic washers

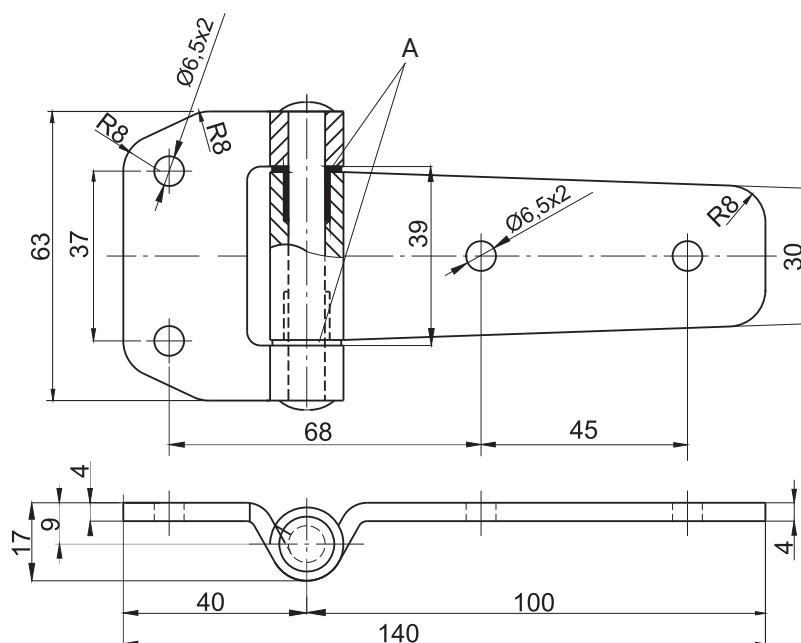

CATALOGUE NUMBER	COMPONENTS	MATERIAL	FINISH [C]
			RAL 9005
3.ST56.100	Holder, Base	Steel zinc plated	04
	Pin	Stainless steel	
3.ST56.100SN	Holder, Base, Pin	Stainless steel	-

A - plastic washers

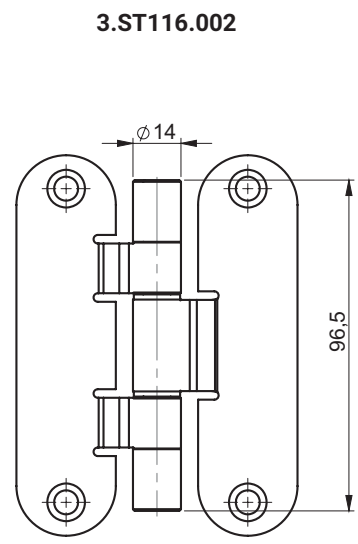
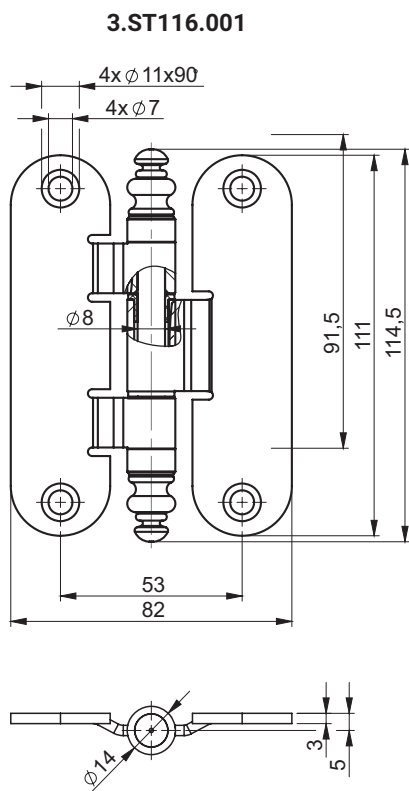

A - plastic bushing

CATALOGUE NUMBER	COMPONENTS	MATERIAL	FINISH
3.ST116.001.01	Holder, Base, Cap	Steel	Zinc plated + enamel
	Pin		Zinc plated
3.ST116.001.02	Holder, Base, Cap		Copper plated + enamel
	Pin		Zinc plated
3.ST116.002.01	Holder, Base, Cap		Zinc plated + enamel
	Pin		Zinc plated
3.ST116.002.02	Holder, Base, Cap		Copper plated + enamel
	Pin		Zinc plated

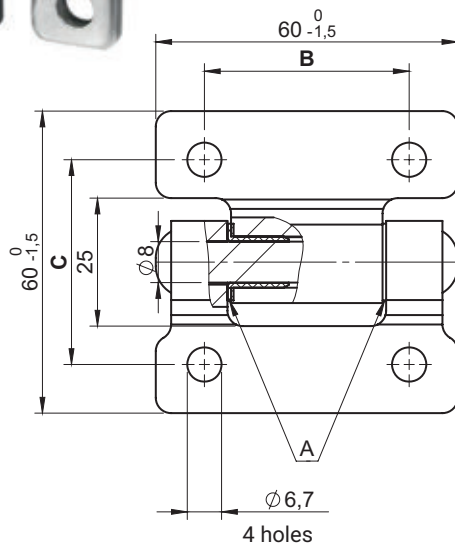
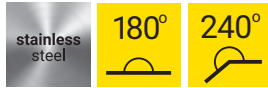

Version .001 .002

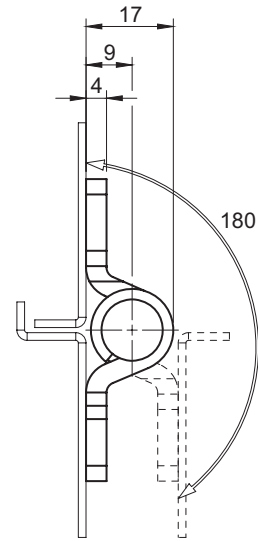

Version .003 .004

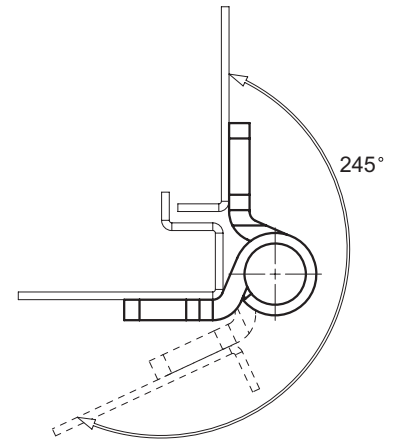

A - plastic bushing

CATALOGUE NUMBER	DIMENSION		COMPONENTS	MATERIAL	FINISH [C]
	B	C			RAL 9005
3.ST56-2.001	40	40	Holder, Base, Pin	Steel zinc plated Stainless steel	02
3.ST56-2.003					
3.ST56-2.002	44	43			
3.ST56-2.004					
3.ST56-2.001SN	40	40	Holder, Base, Pin	Stainless steel	Brak
3.ST56-2.003SN					
3.ST56-2.002SN	44	43			
3.ST56-2.004SN					

How to order:

Catalogue number

Finish [C]

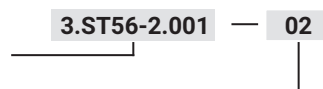

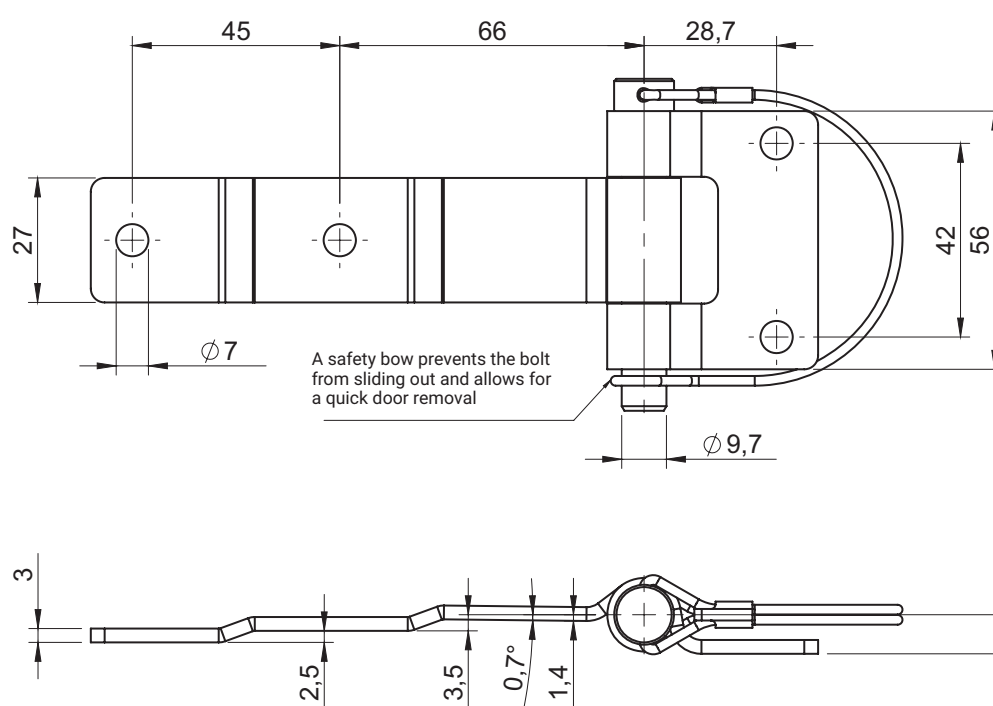

CATALOGUE NUMBER	COMPONENTS	MATERIAL
3.ST134.001SN	Holder, Base, Pin, Safety bow	Stainless steel

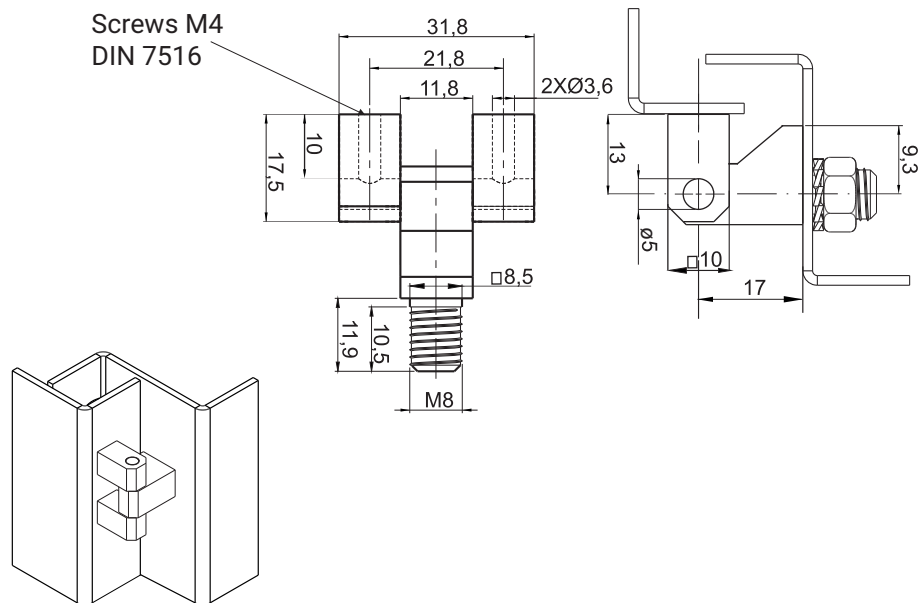

CATALOGUE NUMBER	COMPONENTS	MATERIAL	FINISH [C]
			RAL 9005
3.ZN20.001	Holder, Base	ZAMAK 5	04
	Pin	Steel zinc plated *	

180°

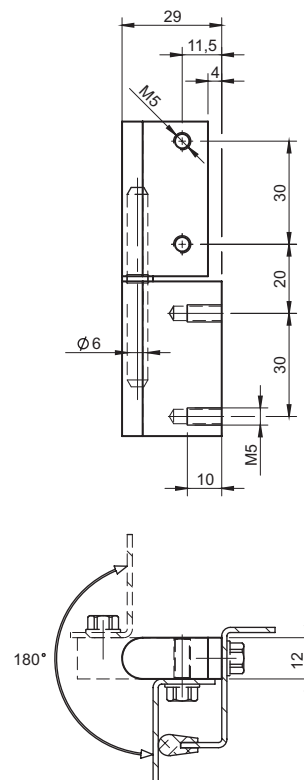
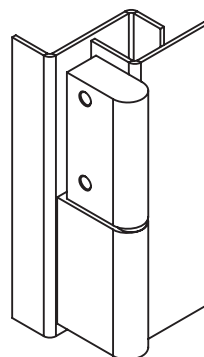

CATALOGUE NUMBER	COMPONENTS	MATERIAL	FINISH [C]
			RAL 9005
3.ST49.001	Holder, Base	Steel	04
	Pin	Steel zinc plated	

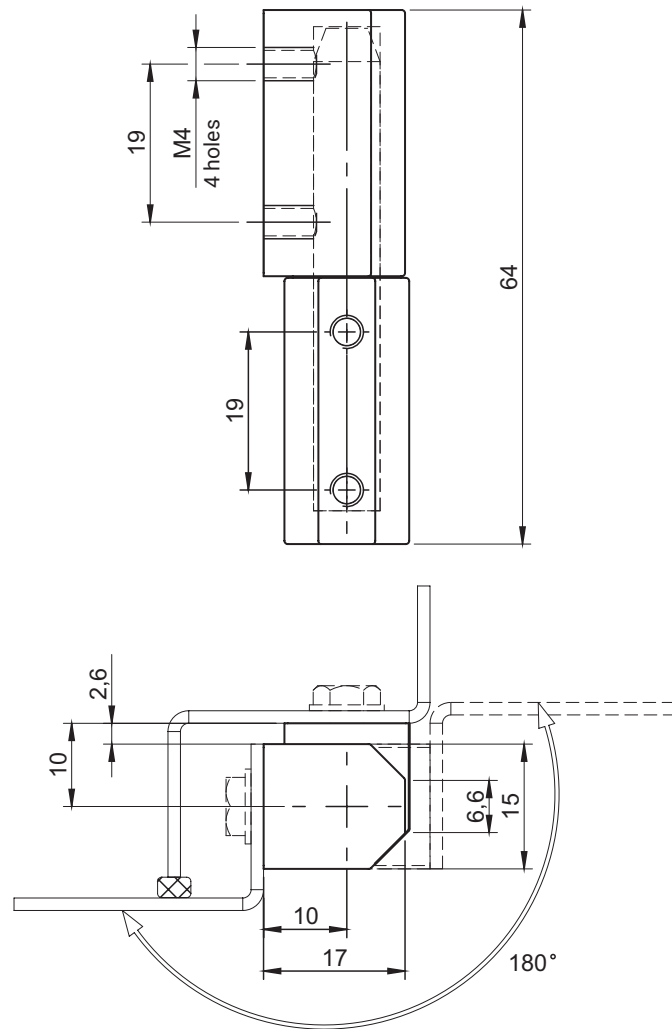

CATALOGUE NUMBER	COMPONENTS	MATERIAL	FINISH [C]	
			Chrome	RAL 9005
3.ZN158.001	Base, Holder	ZAMAK	01	04
	Insert	Stainless Steel	-	-

How to order:

Catalogue number
Finish [C]



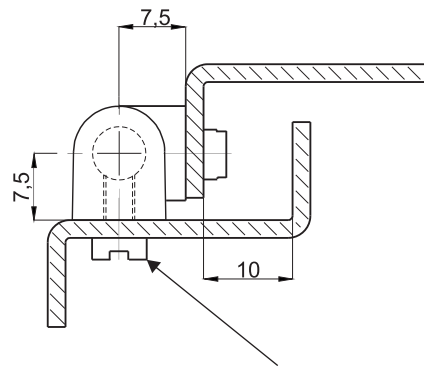
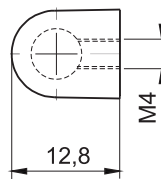
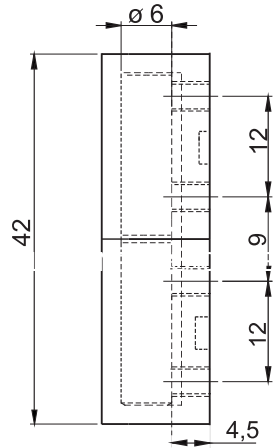

Screws M4 with cylindrical head
DIN 84, ISO1207 **

CATALOGUE NUMBER	COMPONENTS	MATERIAL	FINISH [C]
			RAL 9005
3.ZN155.001	Holder, Base	ZAMAK 5	04
	Pin	Steel zinc plated, *	

* possibility to order stainless steel pin.

**not included order

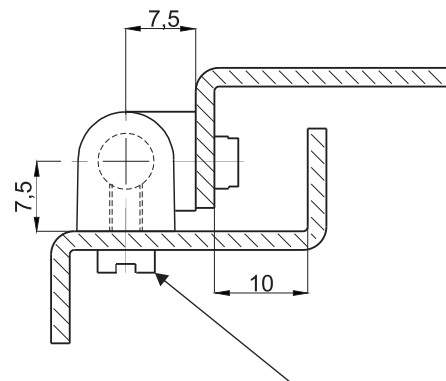
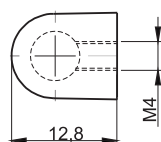
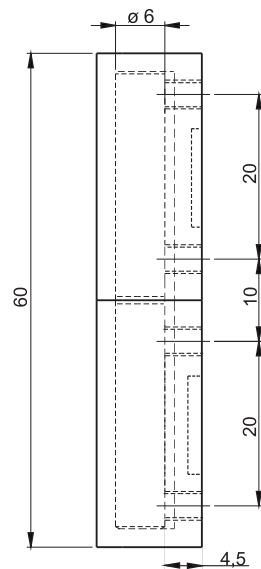

Screws M4 with cylindrical head
DIN 84, ISO1207 **

CATALOGUE NUMBER	COMPONENTS	MATERIAL	FINISH [C]
			RAL 9005
3.ZN155.002	Holder, Base	ZAMAK 5	04
	Pin	Steel zinc plated, *	

* possibility to order stainless steel pin.

**not included order

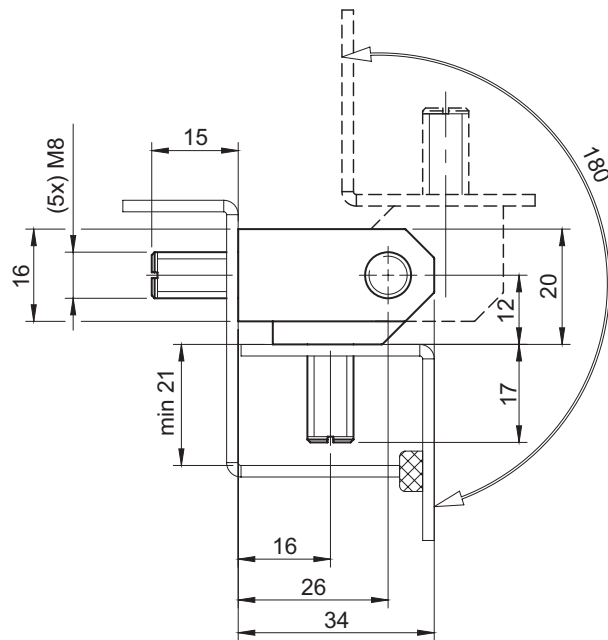
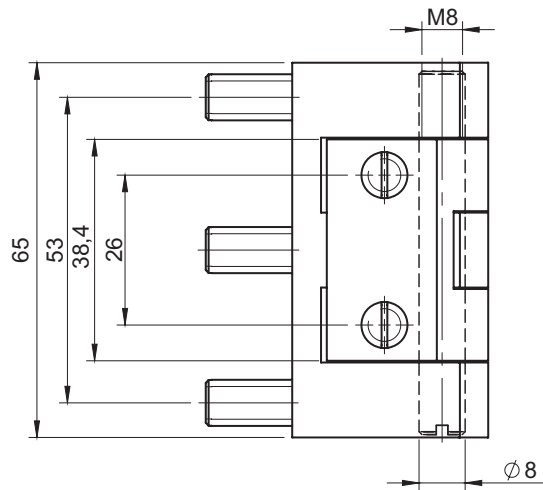

CATALOGUE NUMBER	COMPONENTS	MATERIAL	FINISH [C]
			Nickel
3.ST126.001	Holder, Base, Pin	Steel	02



3.ZN151.001

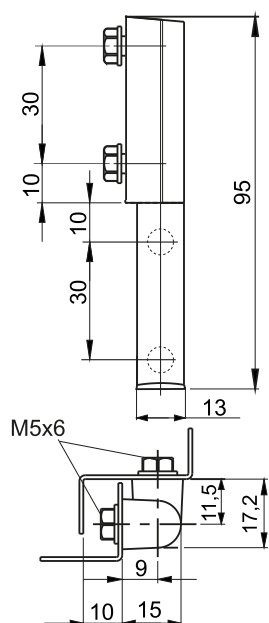

3.ZN152.001

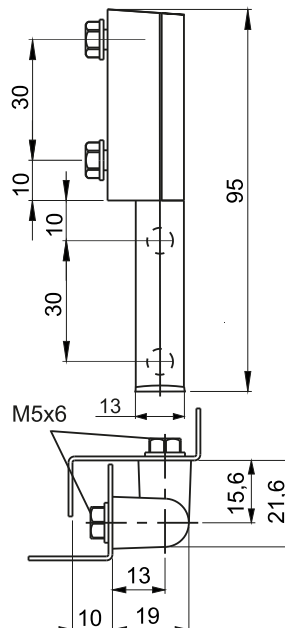

CATALOGUE NUMBER	COMPONENTS	MATERIAL	FINISH [C]	
			RAL 9005	
3.ZN151.001	Holder, Base	Polyamide	07	
3.ZN152.001	Pin	Stainless steel	-	

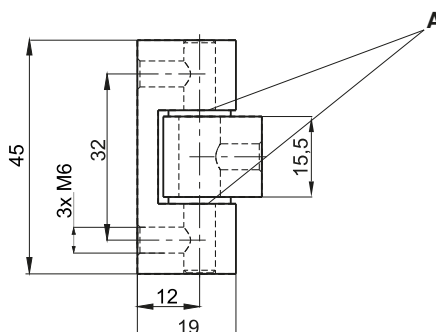
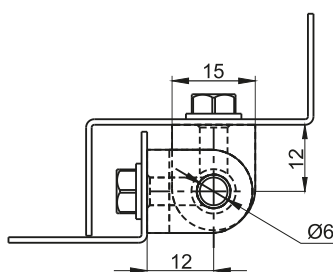

CATALOGUE NUMBER	COMPONENTS	MATERIAL	FINISH [C]	
			Chrome	RAL9005
3.ST53.001	Holder, Base	ZAMAK 5	01	04
	Pin	Stainless steel	-	
3.ST53.002	Holder, Base	Steel	01	04
	Pin	Stainless steel	-	

A - plastic washer

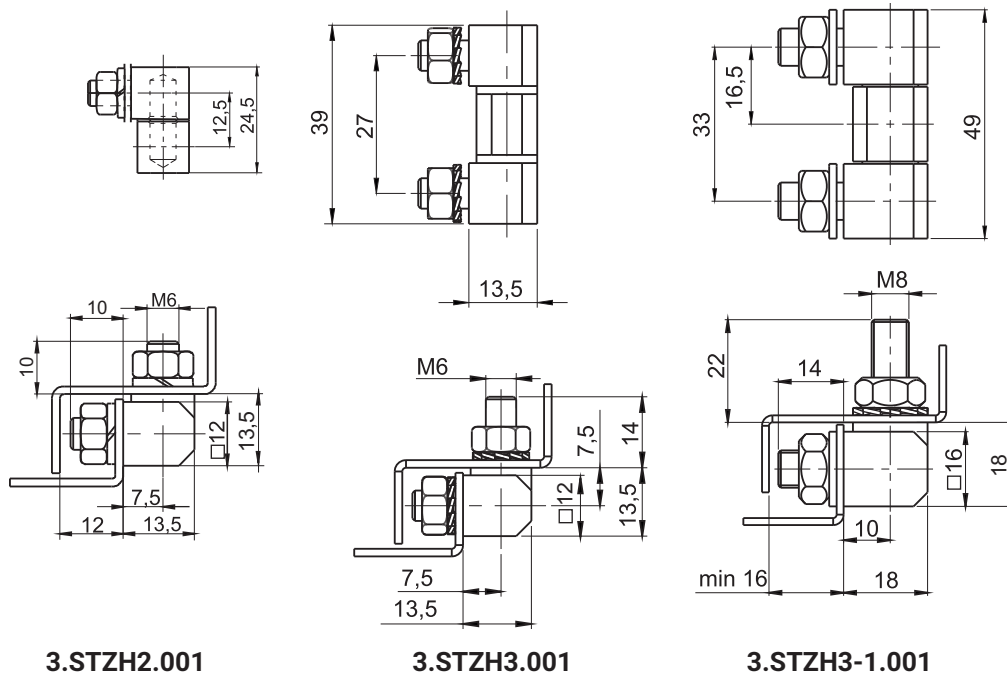

stainless steel



CATALOGUE NUMBER	COMPONENTS	MATERIAL
3.STZH2.001 3.STZH3.001 3.STZH3-1.001	Holder, Base, Pin	Steel zinc plated
3.STZH2.001SN 3.STZH3.001SN 3.STZH3-1.001SN	Holder, Base, Pin	Stainless steel

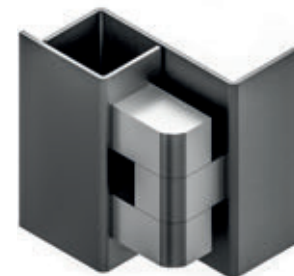
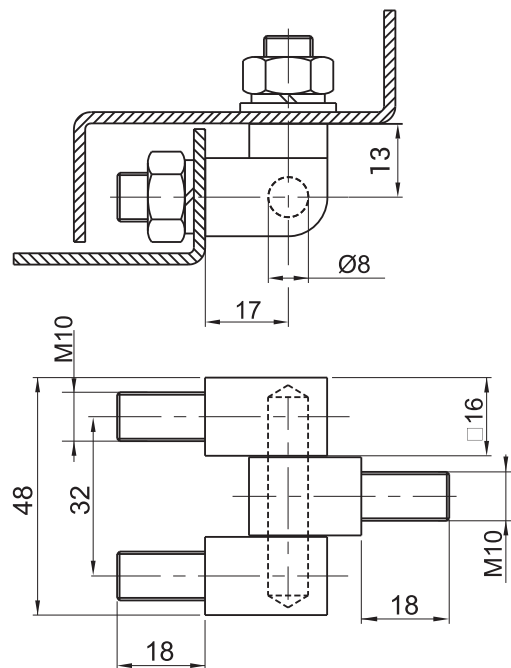

CATALOGUE NUMBER	COMPONENTS	MATERIAL
3.ST73.001	Holder, Base, Pin	Steel zinc plated



3.504.001

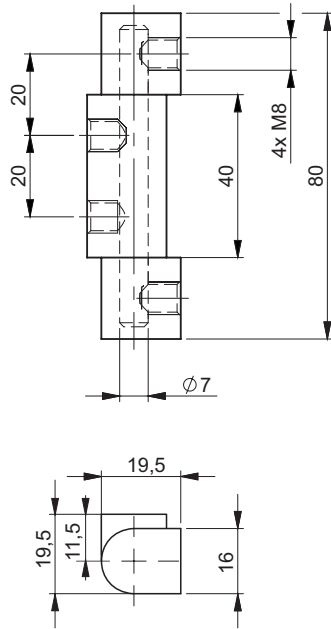

3.505.001

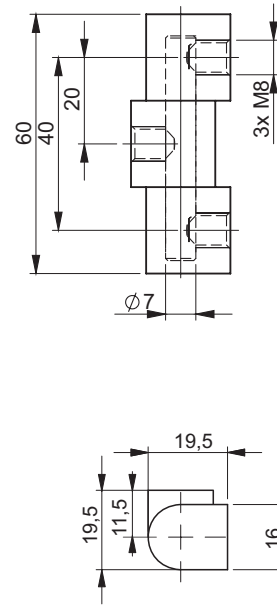

CATALOGUE NUMBER	COMPONENTS	MATERIAL	FINISH [C]	
			Galvanized	Chrome
3.504.001	Holder, Base	Brass	00	01
3.505.001	Pin	Steel zinc plated		

How to order:

Catalogue number
Finish

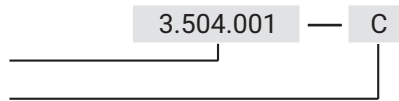

3.506.001

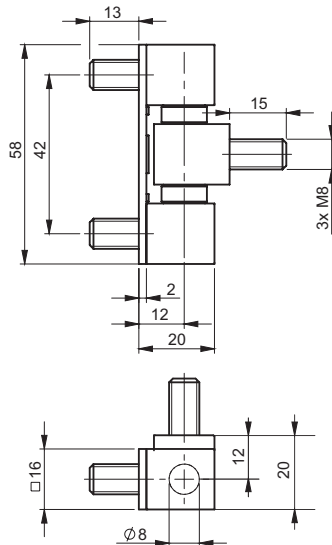

3.507.001

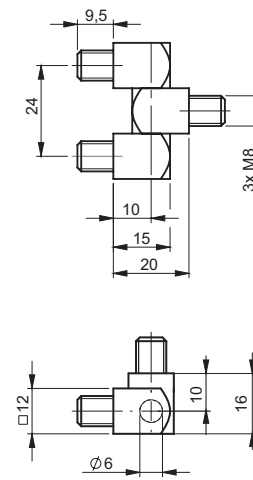

CATALOGUE NUMBER	COMPONENTS	MATERIAL	FINISH [C]
			Nickel
3.506.001	Holder, Base	Steel	02
3.507.001	Pin	Steel zinc plated	

How to order:

Catalogue number
Finish

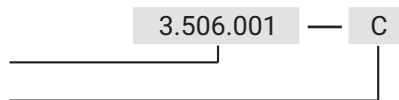

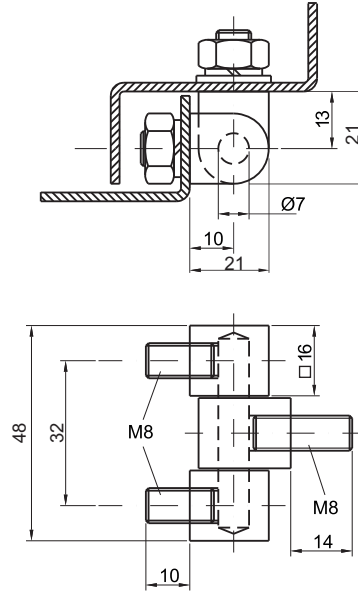

CATALOGUE NUMBER	COMPONENTS	MATERIAL
3.ST17.001	Pin	Steel zinc plated
	Holder, Base	Brass
3.ST17.001SN	Holder, Base, Pin	Stainless steel

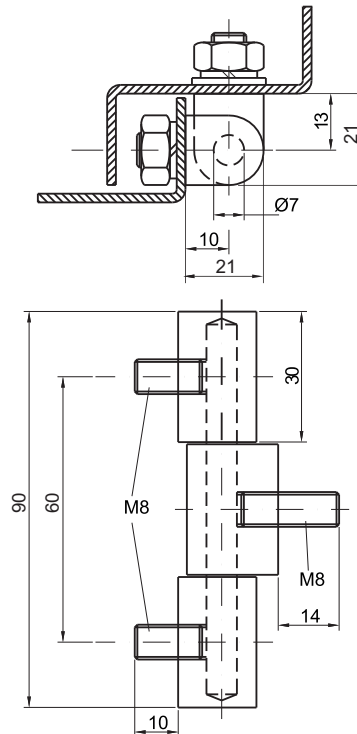

CATALOGUE NUMBER	COMPONENTS	MATERIAL
3.ST18.001	Pin	Steel zinc plated
	Holder, Base	Brass
3.ST18.001SN	Holder, Base, Pin	Stainless steel

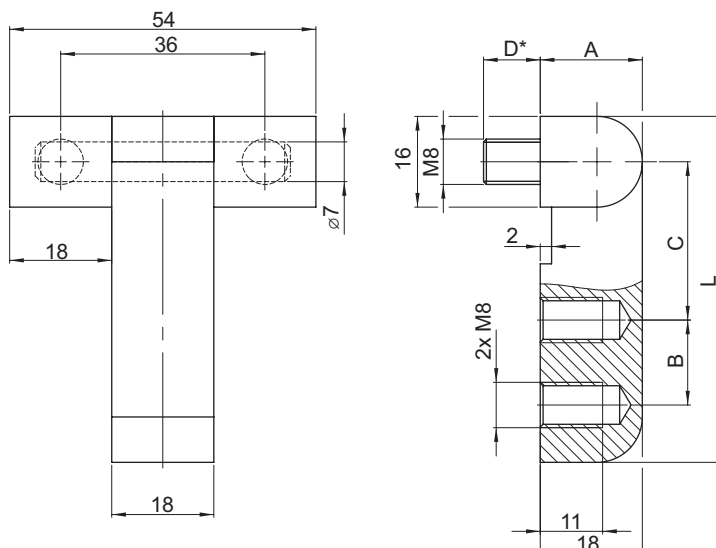

CATALOGUE NO.	L	A	B	C	D	COMPONENTS	MATERIAL
3.ST21.001	61	18	15	28	10	Holder Base Pin	Steel zinc plated Brass zinc plated Steel zinc plated
3.ST21.102	71	18	15	38	10		
3.ST21.103	74	18	23	35	10		
3.ST21.104	93	18	30	45	20		
3.ST21.105	108	18	30	60	20		
3.ST21.106	93	25	30	45	20	Holder, Base Pin	Steel zinc plated
3.ST21.107	108	25	30	60	20		
3.ST21.001SN	61	18	15	28	10	Holder Base Pin	Stainless steel
3.ST21.102SN	71	18	15	38	10		
3.ST21.103SN	74	18	23	35	10		
3.ST21.104SN	93	18	30	45	20		
3.ST21.105SN	108	18	30	60	20		
3.ST21.106SN	93	25	30	45	20	Holder, Base Pin	Stainless steel
3.ST21.107SN	108	25	30	60	20		

* possibility to make in different dimension

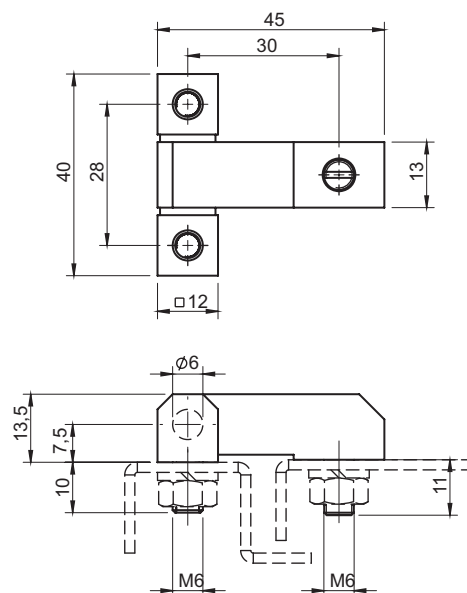

3.ST22.001		
3.ST22.001SN		

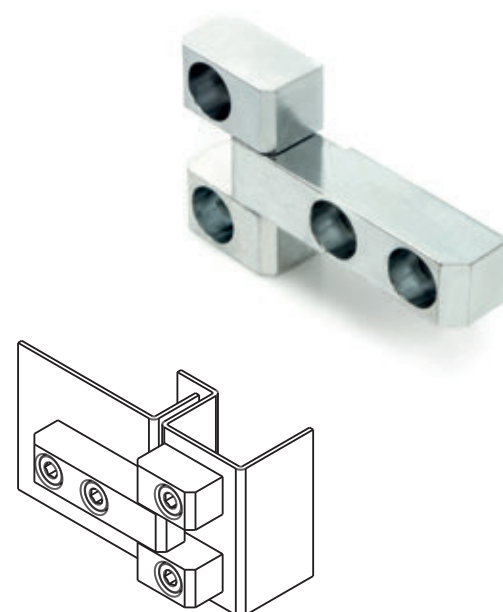
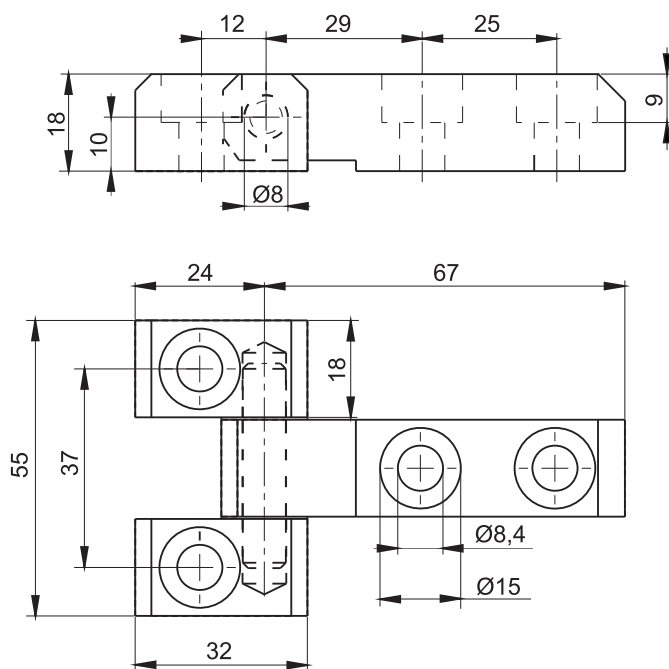

CATALOGUE NUMBER	COMPONENTS	MATERIAL
3.ST29.001	Holder, Base	Steel zinc plated
3.ST29.001SN	Holder, Base	Stainless steel

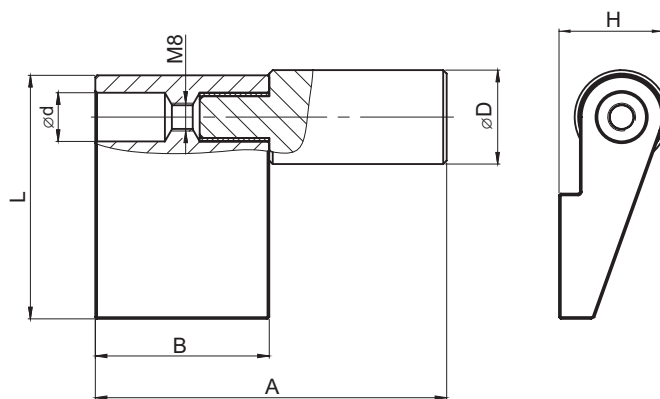

HINGE	D	d	L	H	A	B
3.ST102.001	27	14	70	30	101	50
3.ST102.002	27	14	90	30	101	50
3.ST102.006	20	12	55,5	24	80	40
CATALOGUE NO.	COMPONENTS		MATERIAL			
3.ST102.00X	Fin		Steel			
	Pin					

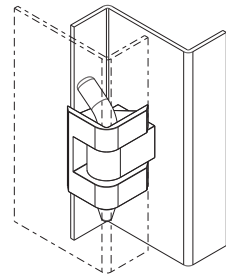

Version
3.ZN70.001
3.ZN70.002

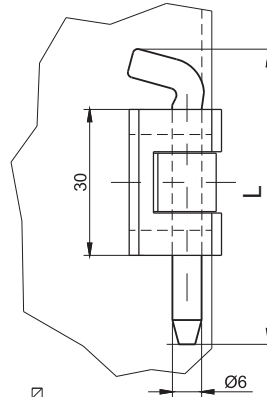

Version
3.ZN70.003

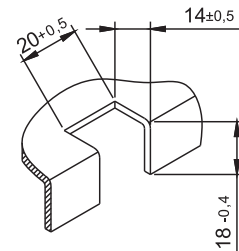
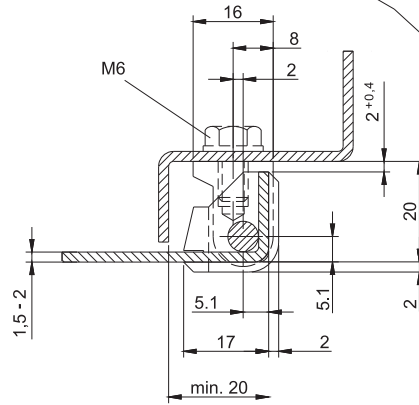
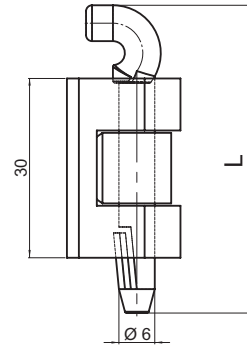

Mounting hole

CATALOGUE NO.	DIMENSION L [mm]		COMPONENTS	MATERIAL	FINISH [C]				
					Chrome	Nickel	RAL9005	RAL7035	RAL7032
3.ZN70.001	56,5	70	Holder, Base	ZAMAK 5	01	02	04	05	12
			Pin	Steel zinc plated					
3.ZN70.003	51,5		Holder, Base	ZAMAK5	01	02	04	05	12
			Pin	POM					
3.ZN70.002SN	56,5	70	Holder, Base, Pin	Stainless steel	-				

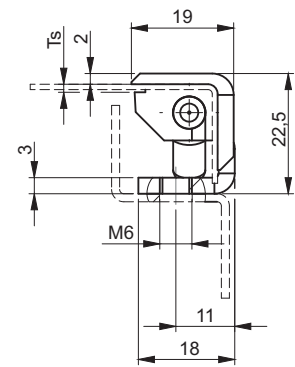
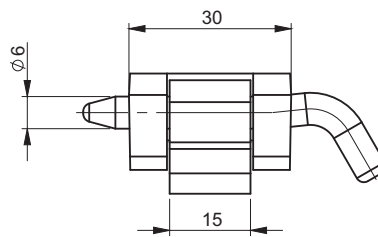
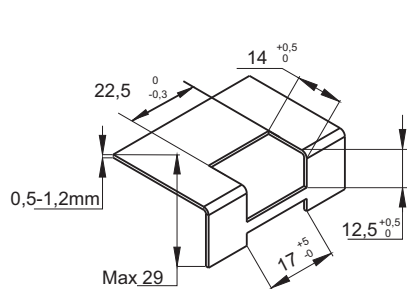

Ts - thickness of metal sheet [mm]

CATALOGUE NUMBER	Ts [mm]	COMPONENTS	MATERIAL	FINISH [C]			
				Chrome	Nickel	RAL9005	RAL7035
3.ZN75.003	0,8-1,2	Holder, Base	ZAMAK 5	01	02	04	05
		Pin	Steel zinc plated				
3.ZN75.004	1,5-2,0	Holder, Base	ZAMAK 5	01	02	04	05
		Pin	Steel zinc plated				

How to order:

Catalogue number

Dimension

Finish

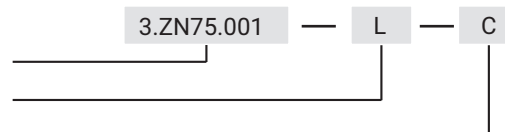

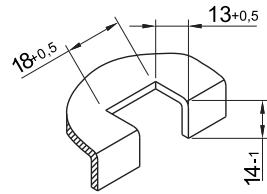

Mounting hole

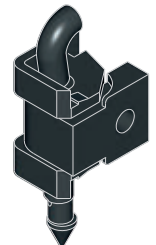
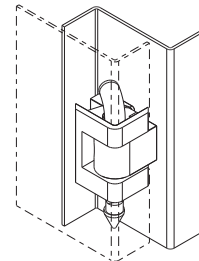
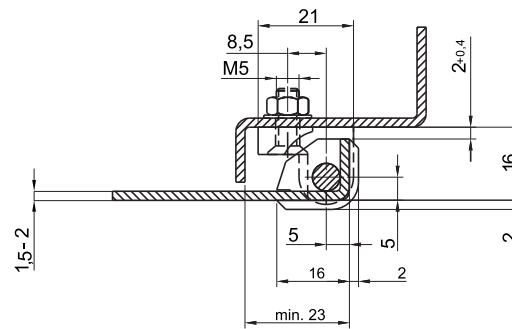
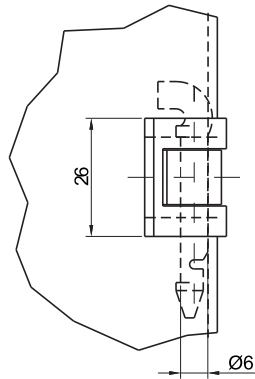

CATALOGUE NUMBER	COMPONENTS	MATERIAL	FINISH [C]	
			RAL9005	RAL7035
3.ZN90.001	Holder, Base, Pin	Polyamide	07	08

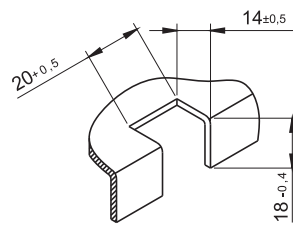
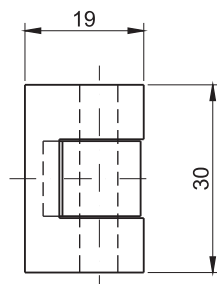

Mounting hole

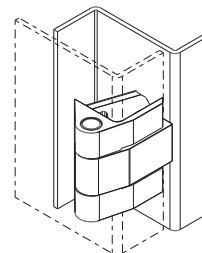
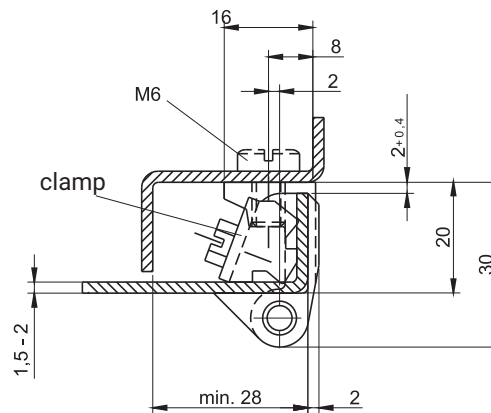

CATALOGUE NUMBER	COMPONENTS	MATERIAL	FINISH [C]	
			RAL9005	RAL7035
3.ZN100.001	Holder, Base	ZAMAK 5	04	05
	Close tight element, Pin	Steel zinc plated		

* possibility to make a different color

How to order:

Catalogue number

Finish

3.ZN100.001

C

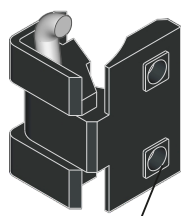

** - with weaning $\square 8 \times 1$ mm

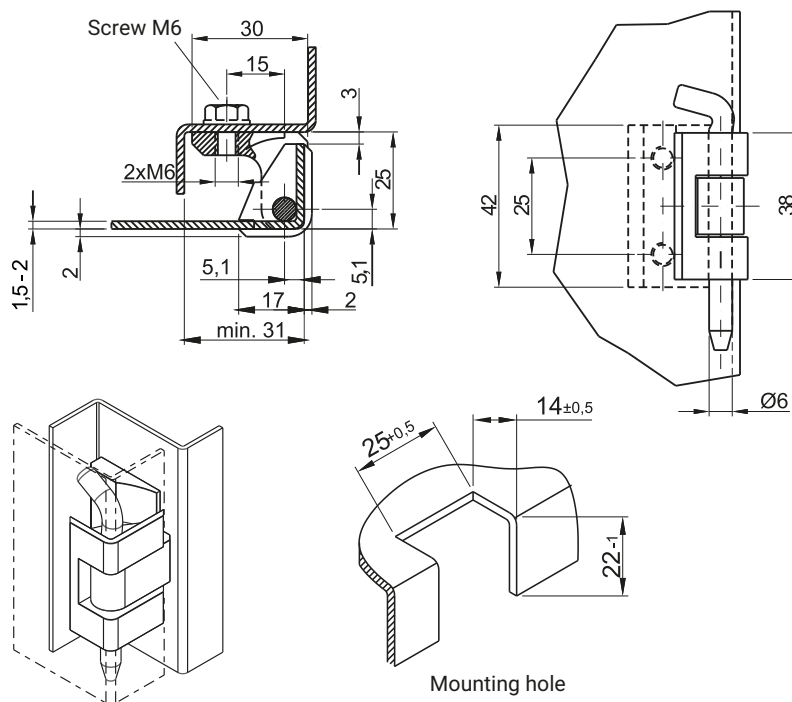

Can be ordered without thread

** possibility to order the hinge with the base with weaning

CATALOGUE NUMBER	COMPONENTS	MATERIAL	FINISH [C]	
			RAL9005	RAL7035
3.ZN80.001	Holder, Base	ZAMAK 5	04	05
	Pin	Steel zinc plated		

* possibility to make a different color

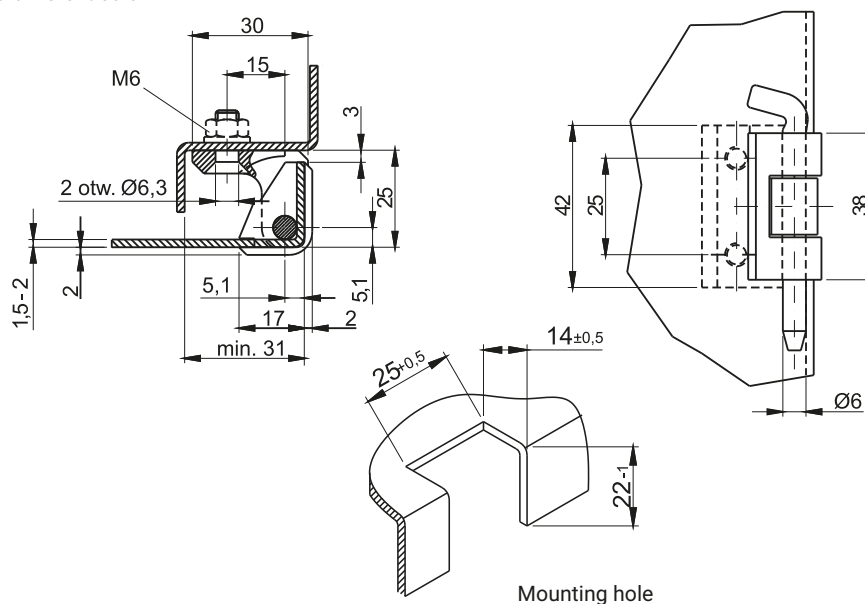

CATALOGUE NUMBER	COMPONENTS	MATERIAL	FINISH [C]	
			RAL9005	RAL7035
3.ZN80.002	Holder, Base	ZAMAK 5	04	05
	Pin	Steel zinc plated		

* possibility to make a different color

How to order:

Catalogue number

Finish

3.ZN80.001 — C

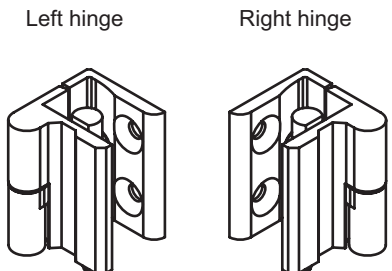
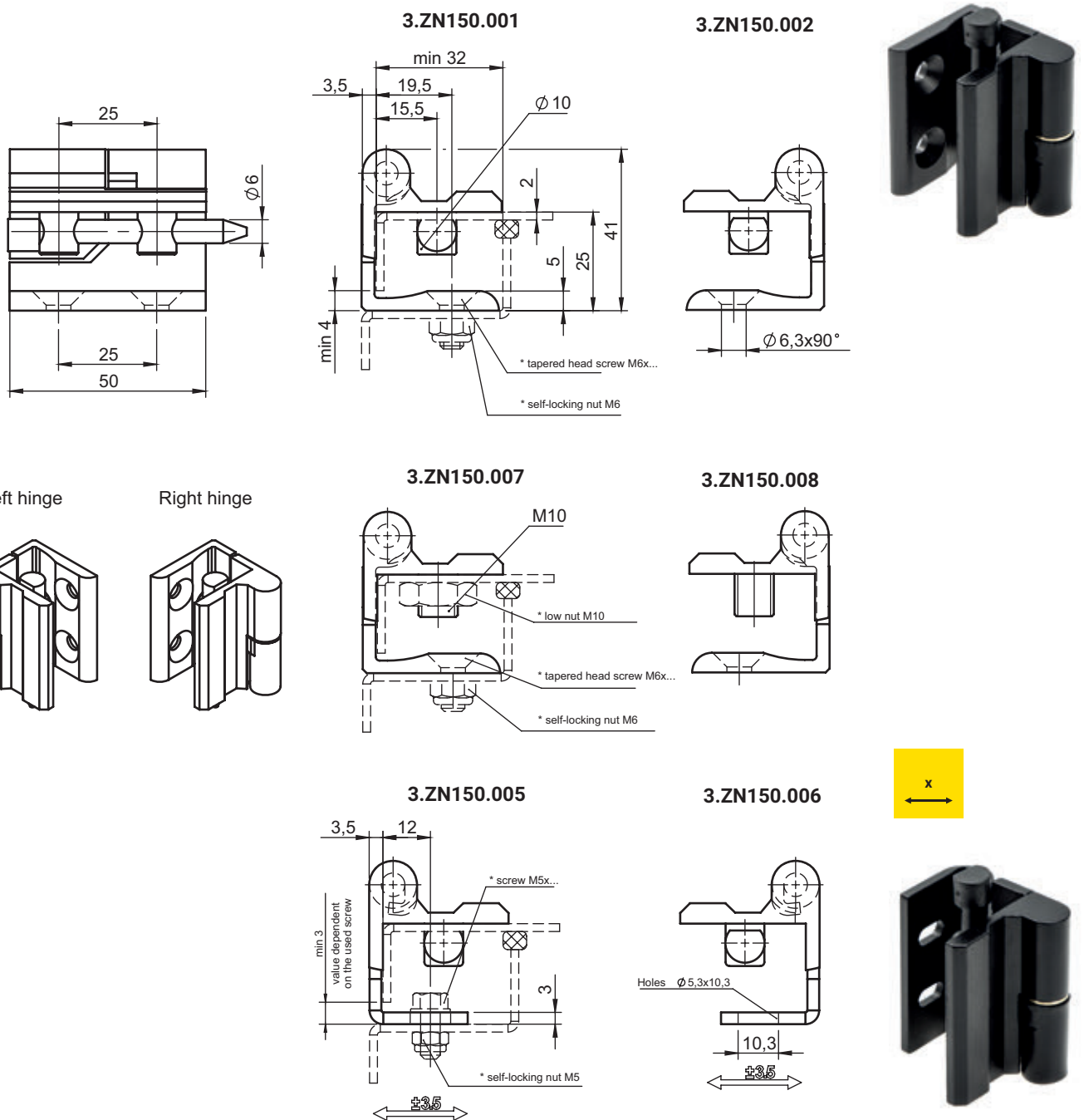

180° opening angle hinge with a lock to prevent the door from being removed from the cabinet when the door is closed and a door opening angle of less than ~60°
 * - not included, to be ordered separately

VERSION	CATALOGUE NUMBER	COMPONENTS	MATERIAL	FINISH [C]
				RAL9005
Right	3.ZN150.001	Holder	ZAMAK 5	04
	3.ZN150.007	Base	ZAMAK 5	
Left	3.ZN150.002	Screw	Poliamid	-
	3.ZN150.008	Pin	Steel zinc plated	
Right	3.ZN150.005	Holder	ZAMAK 5	04
		Base	Steel	
Left	3.ZN150.006	Screw	Poliamid	-
		Pin	Steel zinc plated	

180°



3.ZN154.001

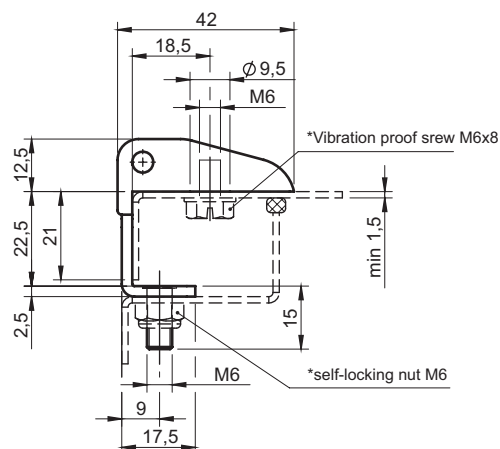
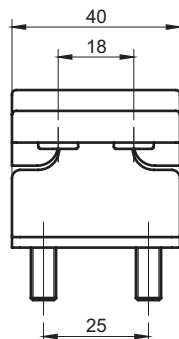

3.ZN154.002



3.ZN154.001

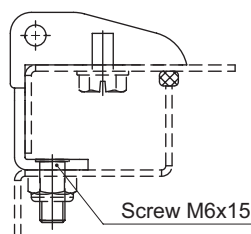

3.ZN154.002

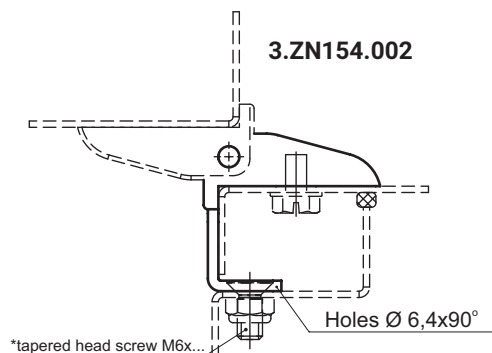

3.ZN154.003



3.ZN154.003

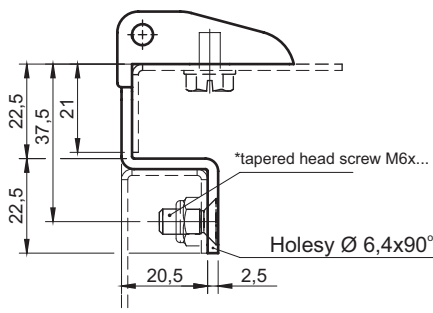

3.ZN154.010

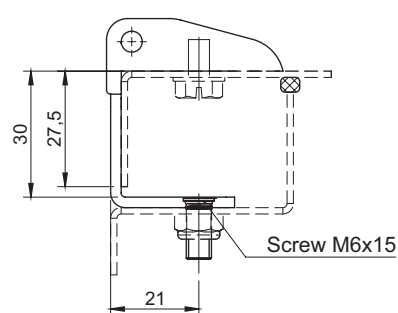

3.ZN154.010



*not included, to be ordered separately

CATALOGUE NUMBER	COMPONENTS	MATERIAL	FINISH [C]	
			RAL9005	RAL7035
3.ZN154.001	Holder	ZAMAK 5	04	05
3.ZN154.002	Base	Steel zinc plated		
3.ZN154.003	Pin	Stainless steel	-	-
3.ZN154.010				

How to order:

Catalogue number

Finish

3.ZN154.001 — C

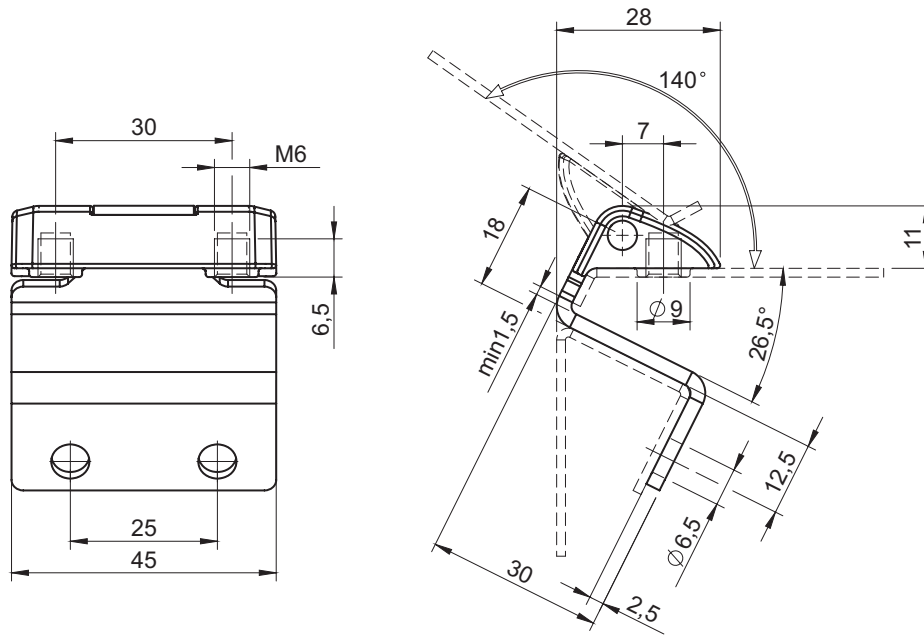

CATALOGUE NUMBER	COMPONENTS	MATERIAL
3.ZN157.001	Holder	ZAMAK
	Base	Steel zinc plated
	Pin	Stainless steel
FINISH [C]		
RAL9005		RAL7035
04		05

How to order:

Catalogue number
Finish [C]

3.ZN154.001 — 04

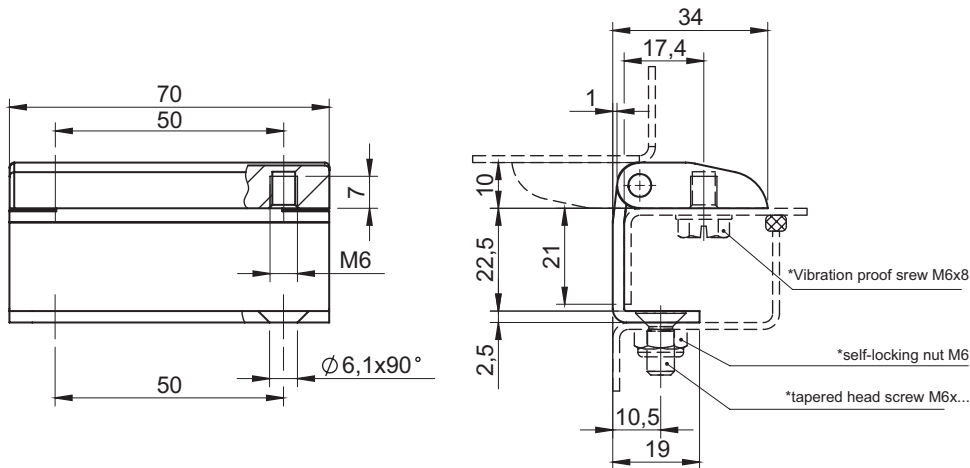

* - not included, to be ordered separately

CATALOGUE NUMBER	COMPONENTS	MATERIAL	FINISH [C]	
			RAL9005	RAL7035
3.ZN154.009	Holder	ZAMAK 5	04	05
	Base	Steel		
	Pin	Stainless steel	-	-

How to order:

Catalogue number
Finish [C]

3.ZN154.009 — 04





1

Locking systems

2

Locks
Latches

3

Internal hinges

4

Clamps

5

Accessories

6

Gasketing profiles

7

Custom products



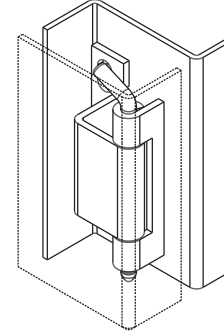
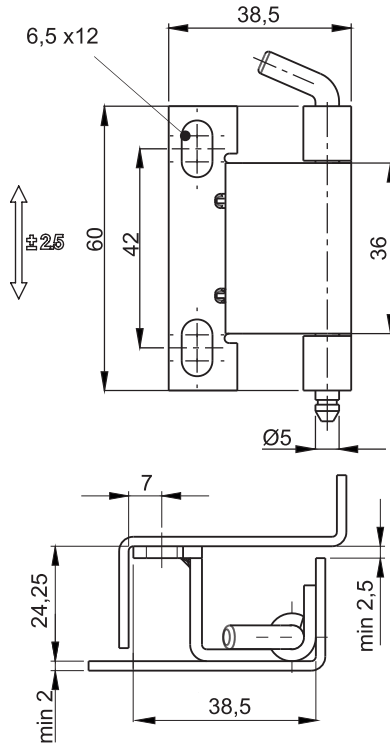

CATALOGUE NUMBER	COMPONENTS	MATERIAL
3.ST4-1.001	Base, Pin	Steel zinc plated
	Holder	Steel
3.ST4-1.001SN	Holder, Base, Pin	Stainless steel

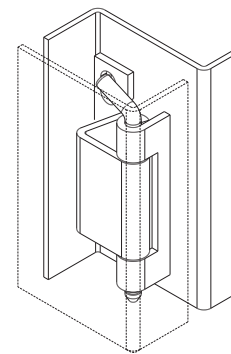
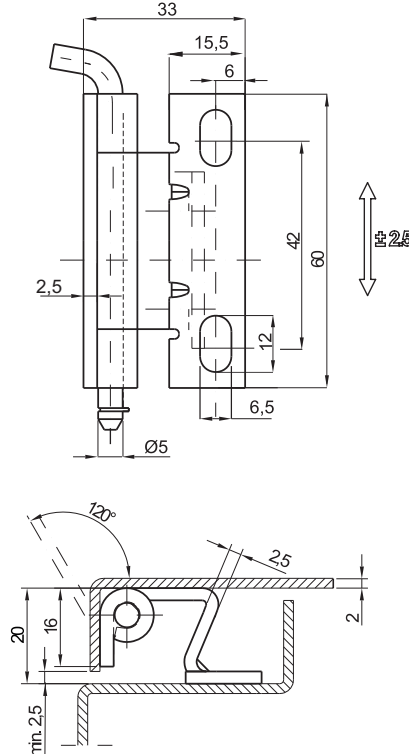

CATALOGUE NUMBER	COMPONENTS	MATERIAL
3.ST4.001	Base, Pin	Steel zinc plated
	Holder	Steel
3.ST4.001SN	Holder, Base, Pin	Stainless steel

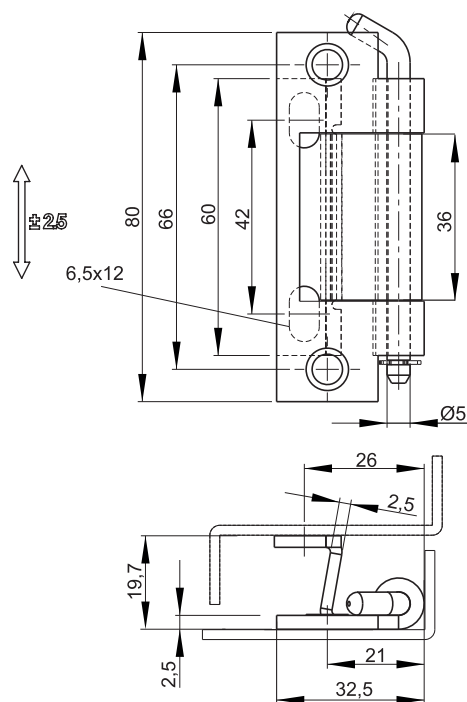

CATALOGUE NUMBER	COMPONENTS	MATERIAL
3.ST4-2.001	Holder, Base, Pin	Steel zinc plated
3.ST4-2.001SN	Holder, Base, Pin	Stainless steel

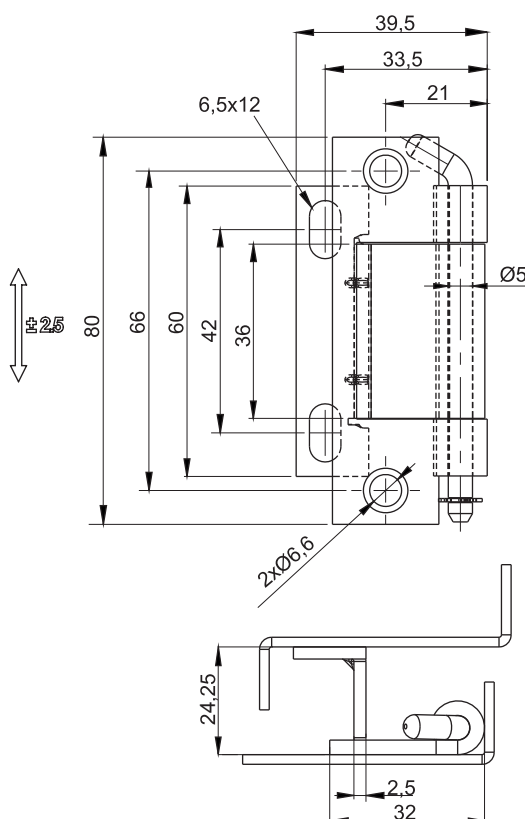

CATALOGUE NUMBER	COMPONENTS	MATERIAL
3.ST4-4.001	Holder, Base, Pin	Steel zinc plated
3.ST4-4.001SN	Holder, Base, Pin	Stainless steel

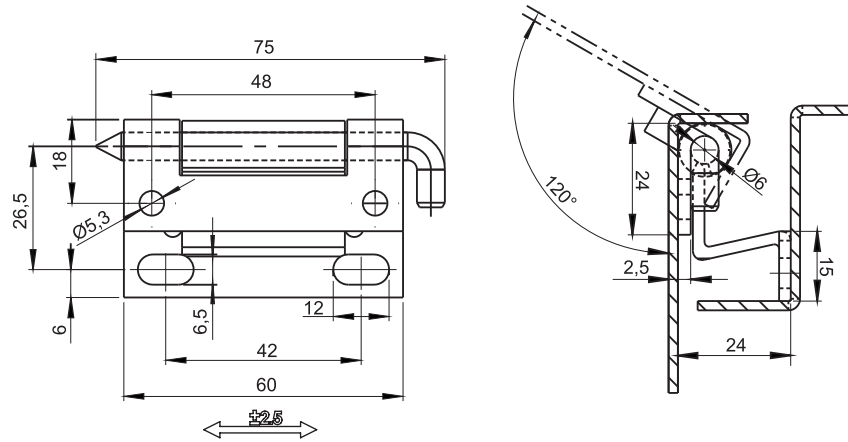

CATALOGUE NUMBER	COMPONENTS	MATERIAL
3.ST27.001	Holder, Base, Pin	Steel zinc plated
3.ST27.001SN	Holder, Base, Pin	Stainless steel

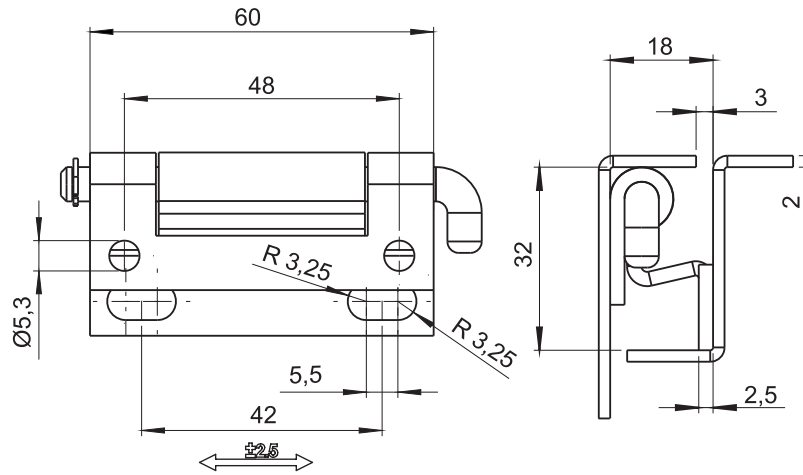

CATALOGUE NUMBER	COMPONENTS	MATERIAL
3.ST27-1.001	Holder, Base, Pin	Steel zinc plated
3.ST27-1.001SN	Holder, Base, Pin	Stainless steel

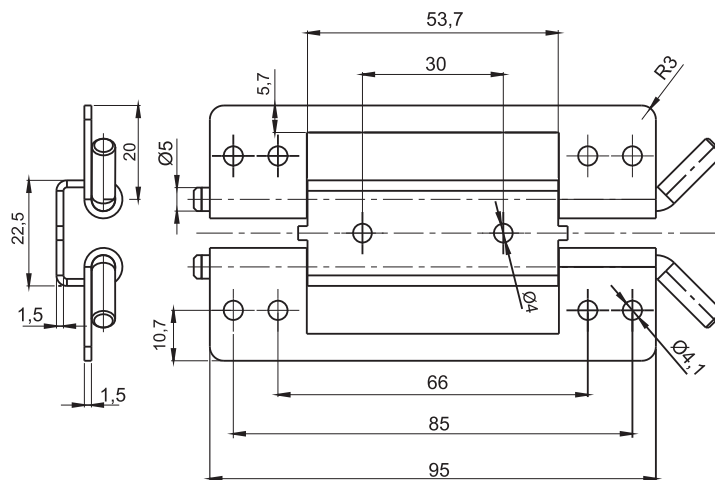

CATALOGUE NUMBER	COMPONENTS	MATERIAL
3.ST54.001	Holder, Base, Pin	Steel zinc plated
3.ST54.001SN	Holder, Base, Pin	Stainless steel

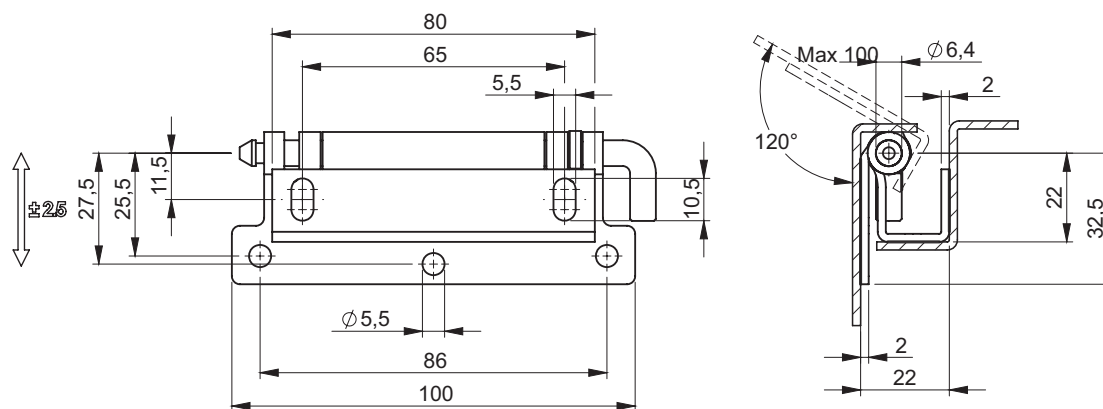

CATALOGUE NO.	COMPONENTS	MATERIAL
3.ST115.001	Holder, Base, Pin	Steel zinc plated
	Blockade	POM
3.ST115.001SN	Holder, Base, Pin	Stainless steel
	Blockade	POM

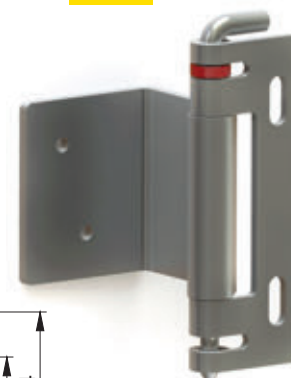
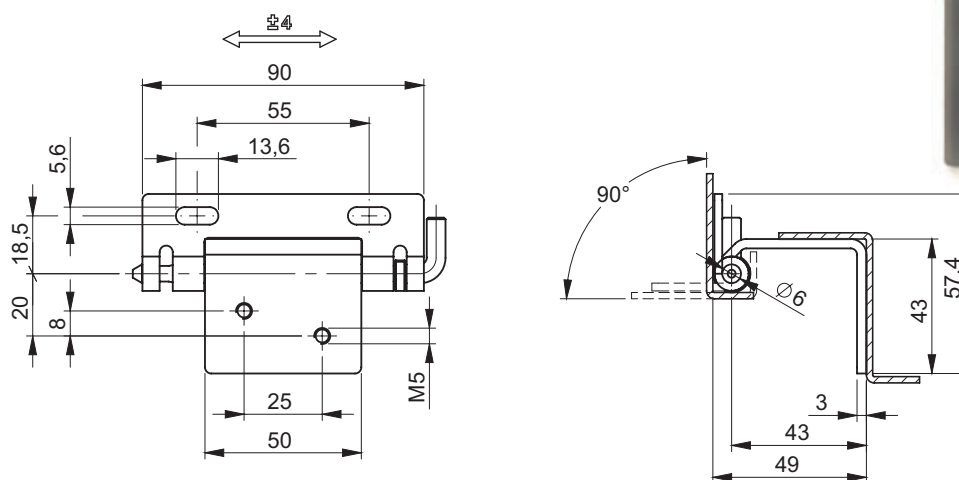

CATALOGUE NO.	COMPONENTS	MATERIAL
3.ST115.002	Holder, Base, Pin	Steel zinc plated
	Pin blockage	POM
3.ST115.002SN	Holder, Base, Pin	Stainless steel

stainless steel

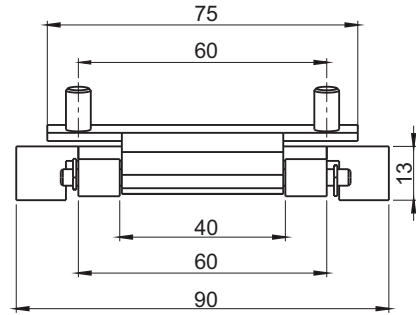
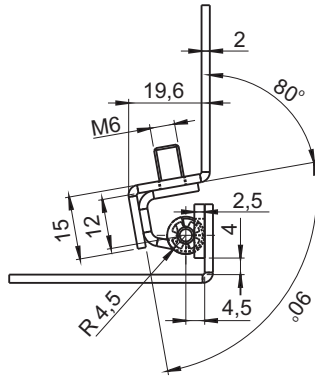

CATALOGUE NUMBER	COMPONENTS	MATERIAL
3.ST47.001	Base, Pin	Steel zinc plated
	Holder	Steel
3.ST47.001SN	Holder, Base, Pin	Stainless steel

stainless steel

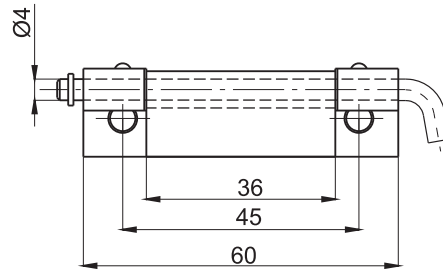
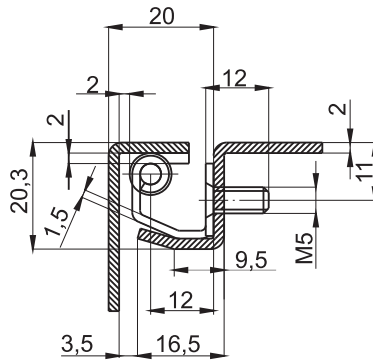

CATALOGUE NUMBER	COMPONENTS	MATERIAL
3.ST47.002	Base, Pin	Steel zinc plated
	Holder	Steel
3.ST47.002SN	Holder, Base, Pin	Stainless steel

stainless steel



3.ST13.002

3.ST13.001

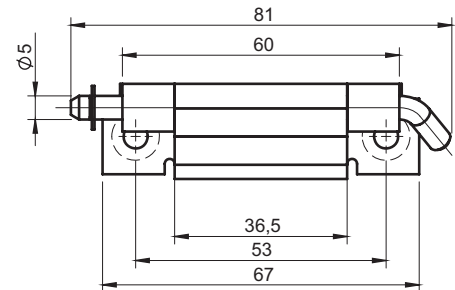
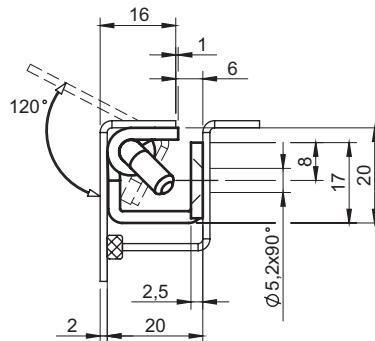
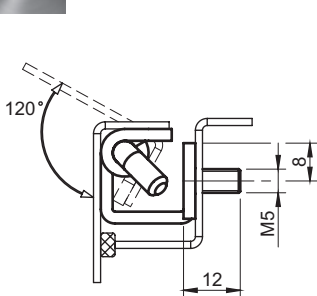

CATALOGUE NUMBER	COMPONENTS	MATERIAL
3.ST13.001	Base, Pin	Steel zinc plated
3.ST13.002	Holder	Steel
3.ST13.001SN	Holder, Base, Pin	Stainless steel
3.ST13.002SN		

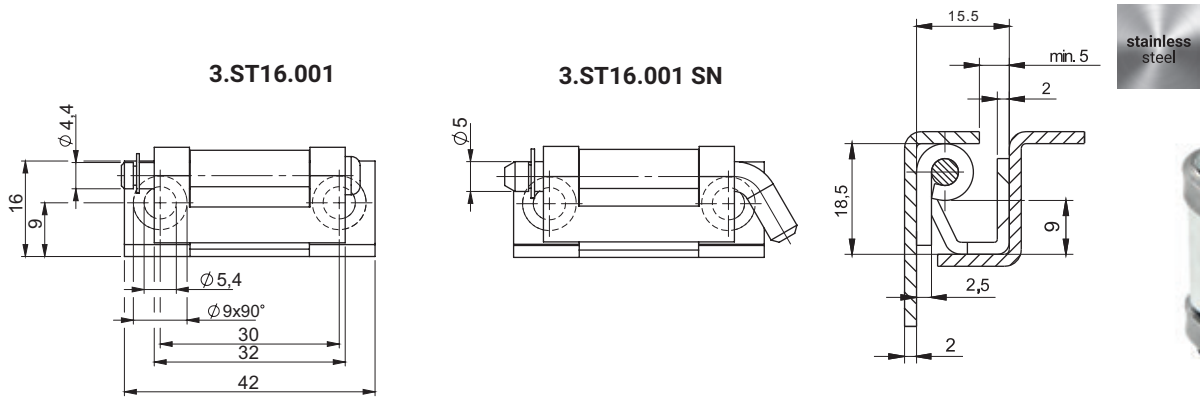

CATALOGUE NUMBER	COMPONENTS	MATERIAL
3.ST16.001	Base, Pin	Steel zinc plated
	Holder	Steel
3.ST16.001SN	Holder, Base, Pin	Stainless steel

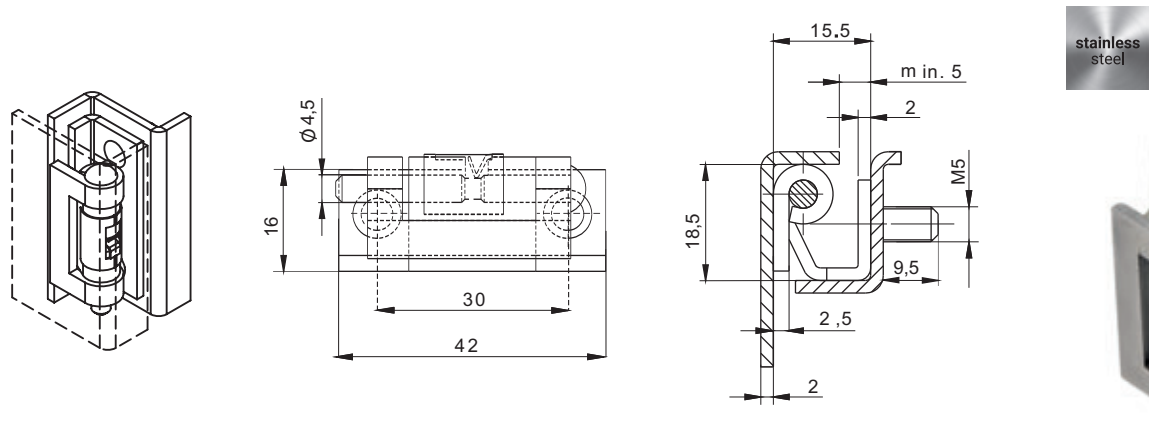

CATALOGUE NUMBER	COMPONENTS	MATERIAL
3.ST16.004	Holder	Steel
	Base, Pin	Steel zinc plated
	Spring	Stainless steel

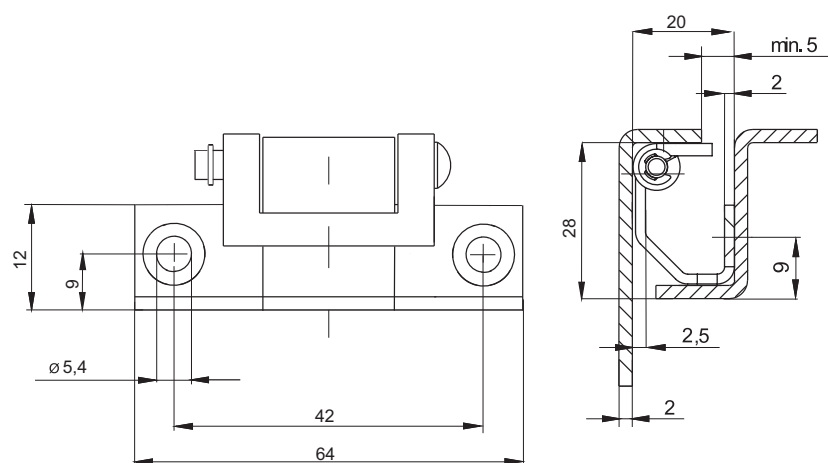

CATALOGUE NUMBER	COMPONENTS	MATERIAL
3.ST16.006	Base, Pin	Steel zinc plated
	Holder	Steel

stainless steel

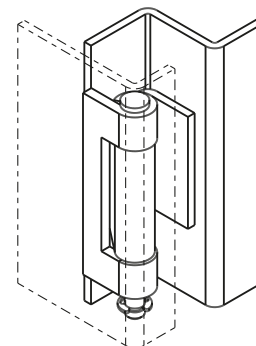
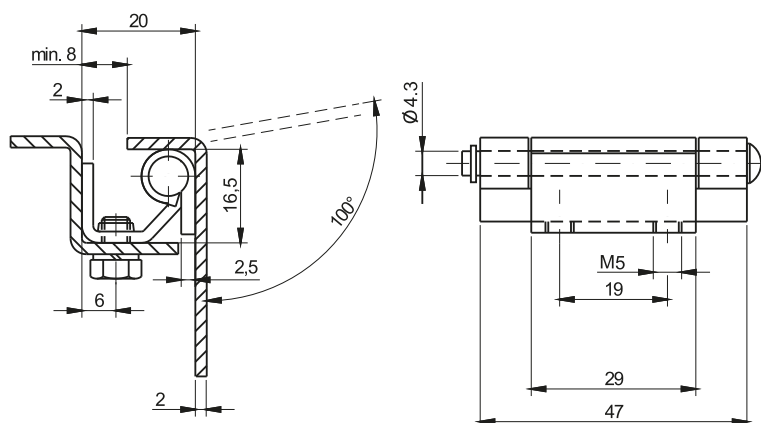

CATALOGUE NUMBER	COMPONENTS	MATERIAL
3.ST5.001	Base, Pin	Steel zinc plated
	Holder	Steel
3.ST5.001SN	Holder, Base, Pin	Stainless steel

stainless steel

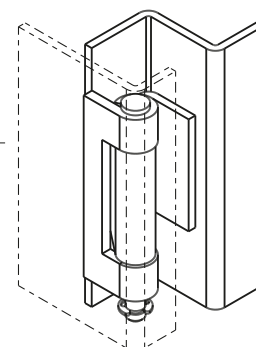
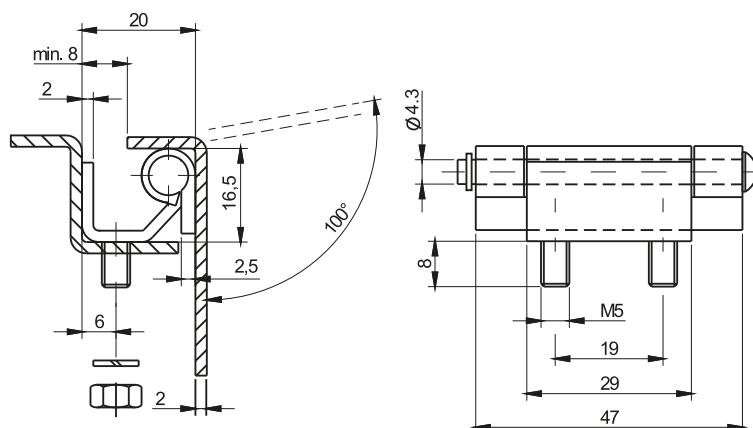

CATALOGUE NUMBER	COMPONENTS	MATERIAL
3.ST5.003	Base, Pin	Steel zinc plated
	Holder	Steel
3.ST5.003SN	Holder, Base, Pin	Stainless steel

stainless steel



Thickness [mm]	X
1,5	01
2	02
2,5	03

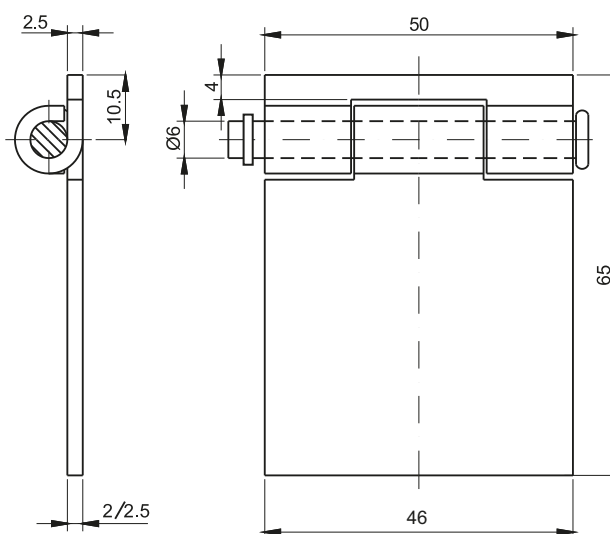

CATALOGUE NUMBER	COMPONENTS	MATERIAL
3.ST6.001.X	Holder, Base	Steel
	Pin	Steel zinc plated
3.ST6.001SN.X	Holder, Base, Pin	Stainless steel

stainless steel

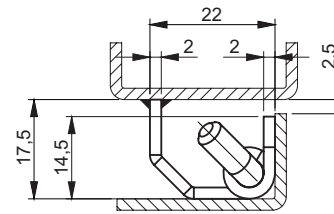
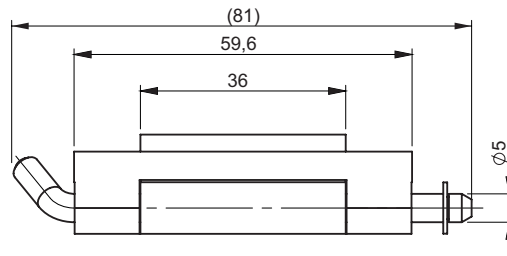

CATALOGUE NUMBER	COMPONENTS	MATERIAL
3.ST43.001	Holder	Steel
	Pin, Base	Steel
3.ST43.001SN	Holder, Base, Pin	Stainless steel

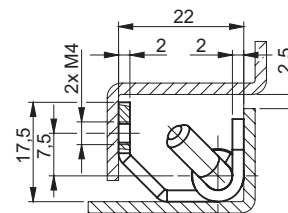
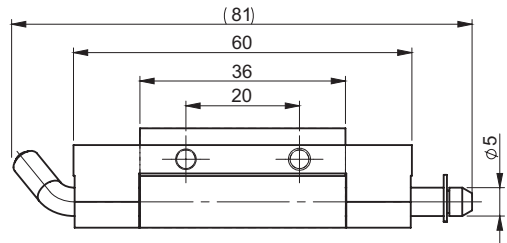

CATALOGUE NUMBER	COMPONENTS	MATERIAL
3.ST43.002	Holder	Steel
	Pin, Base	Steel zinc plated
3.ST43.002SN	Holder, Base, Pin	Stainless steel

stainless steel

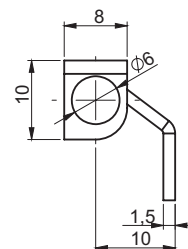
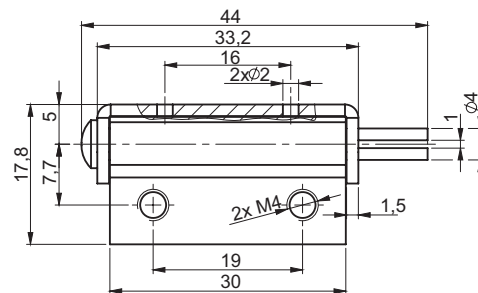

CATALOGUE NUMBER	COMPONENTS	MATERIAL
3.ST43-2.001	Holder, Base, Pin	Steel zinc plated
3.ST43-2.001SN	Holder, Base, Pin	Stainless steel

stainless steel

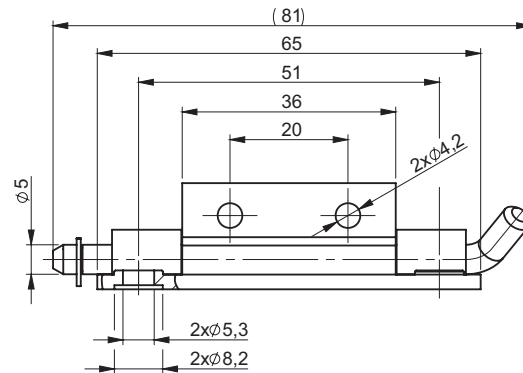
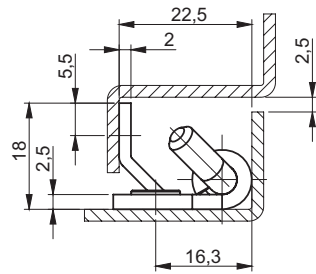

CATALOGUE NUMBER	COMPONENTS	MATERIAL
3.ST43.003	Holder, Pin	Steel zinc plated
	Base	Steel zinc plated
3.ST43.003SN	Holder, Base, Pin	Stainless steel

stainless steel

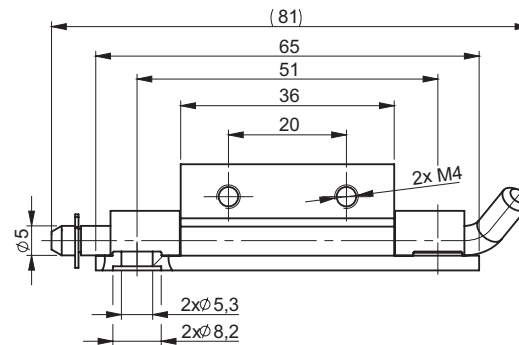
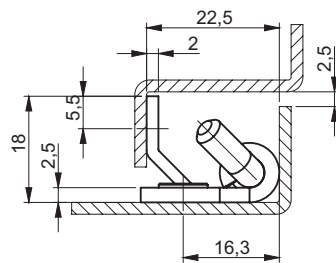

CATALOGUE NUMBER	COMPONENTS	MATERIAL
3.ST43.004*	Holder, Pin	Steel zinc plated
	Base	Steel zinc plated
3.ST43.004SN	Holder, Base, Pin	Stainless steel

* - possibility to order the hinge version without cover

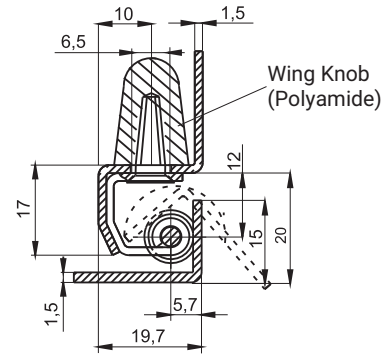
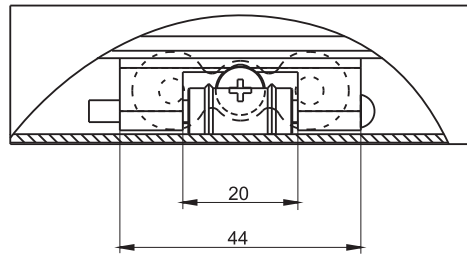

CATALOGUE NUMBER	COMPONENTS	MATERIAL
3.ST32.001	Base, Pin	Steel zinc plated
	Holder	Steel
3.ST32.001SN	Holder, Base, Pin	Stainless steel

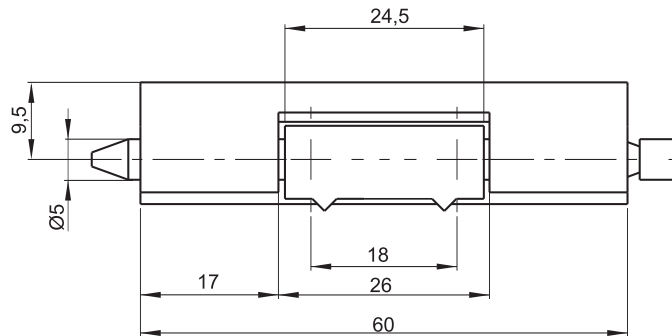
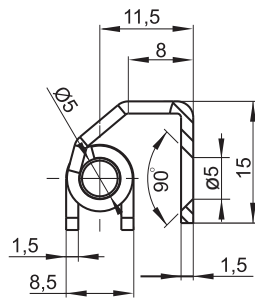

CATALOGUE NUMBER	COMPONENTS	MATERIAL
3.ST32.003	Base, Pin	Steel zinc plated
	Holder	Steel
3.ST32.003SN	Holder, Base, Pin	Stainless steel

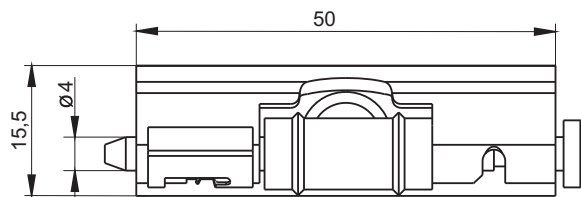
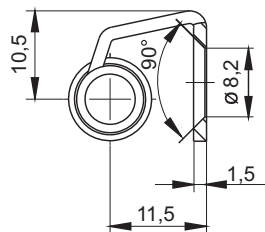

CATALOGUE NUMBER	COMPONENTS	MATERIAL
3.ST32.005	Base, Pin	Steel zinc plated
	Holder	Steel

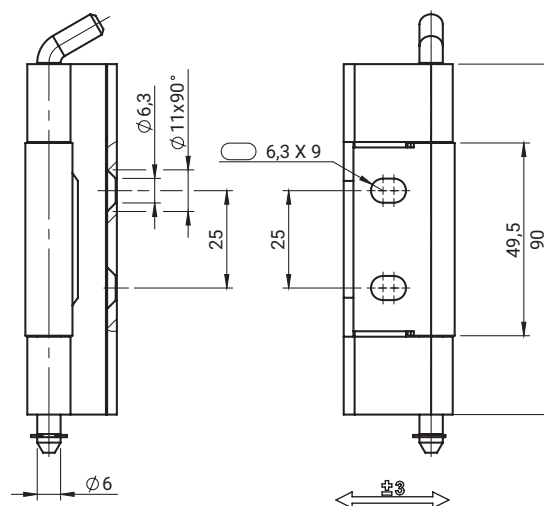
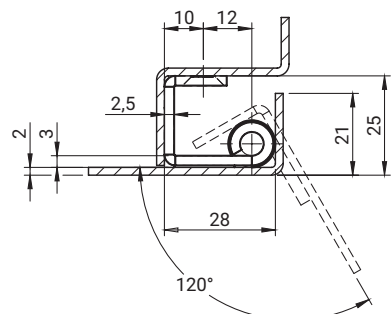

CATALOGUE NUMBER	COMPONENTS	MATERIAL
3.ST12.001	Holder, Base, Pin	Steel zinc plated
3.ST12.001SN	Holder, Base, Pin	Stainless steel

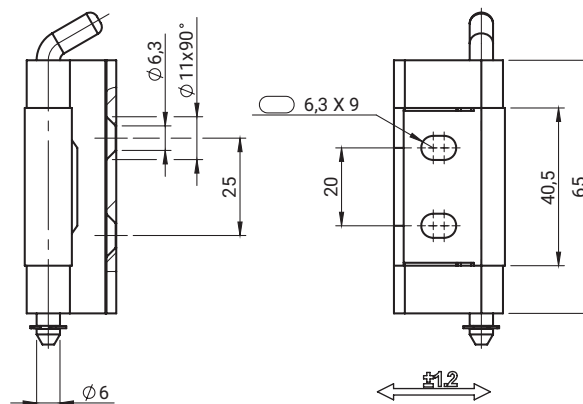
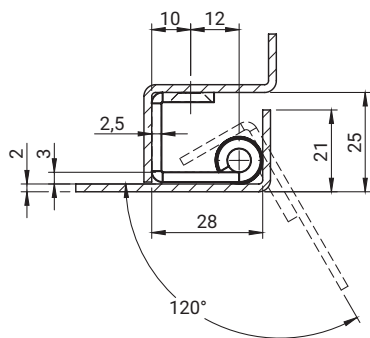

CATALOGUE NUMBER	COMPONENTS	MATERIAL
3.ST12-2.001	Holder, Base, Pin	Steel zinc plated
3.ST12-2.001SN	Holder, Base, Pin	Stainless steel

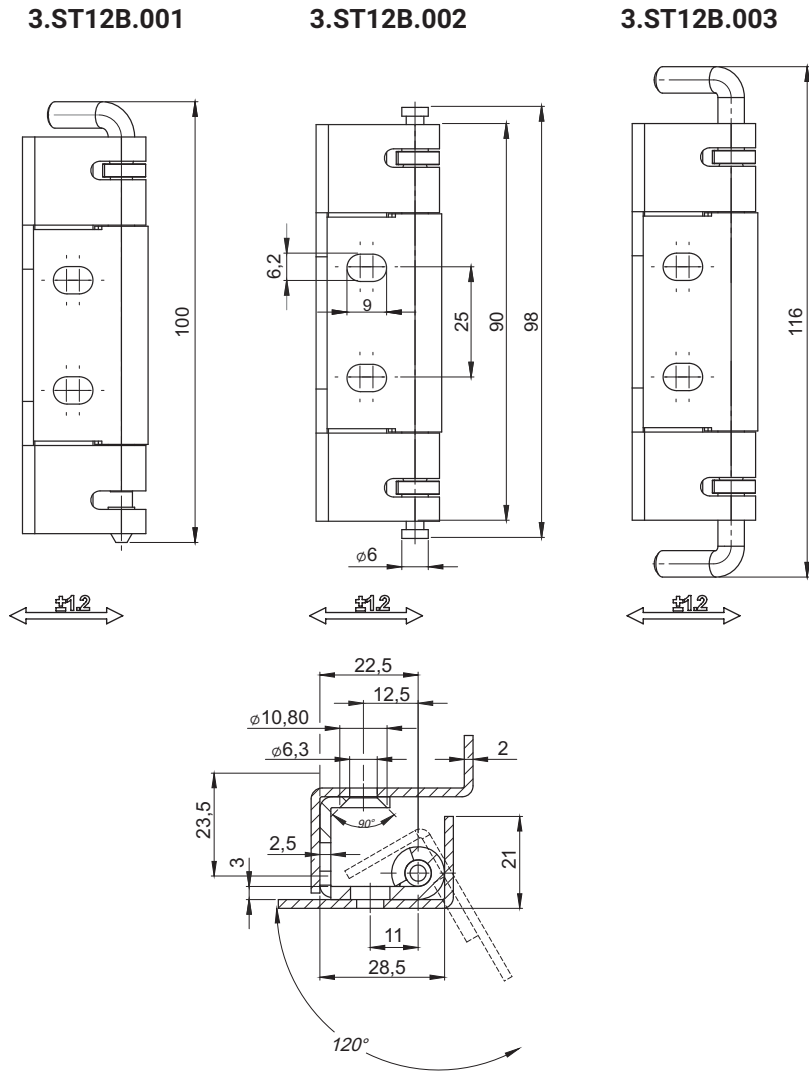

CATALOGUE NO.	COMPONENTS	MATERIAL
3.ST12B.001	Holder, Base, Pin	Steel zinc plated
3.ST12B.002	Blockade	POM
3.ST12B.003		
3.ST12B.001SN	Holder, Base, Pin	Stainless steel
3.ST12B.002SN	Blockade	POM
3.ST12B.003SN		

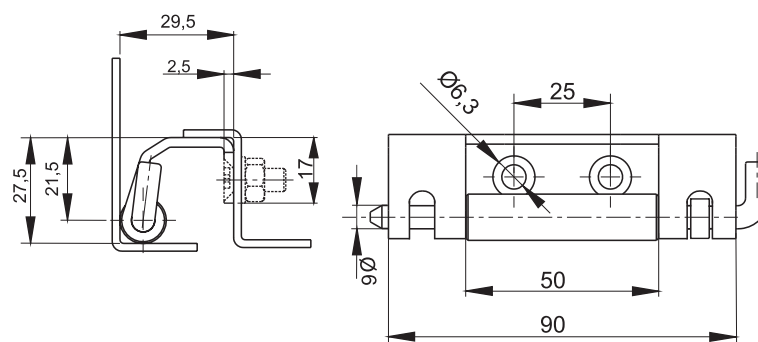

CATALOGUE NUMBER	COMPONENTS	MATERIAL
3.ST12-1B.001	Holder, Base, Pin	Steel zinc plated
	Blockade	POM
3.ST12-1B.001SN	Holder, Base, Pin	Stainless steel

stainless steel

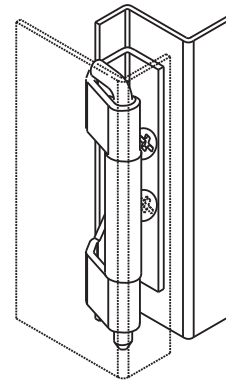
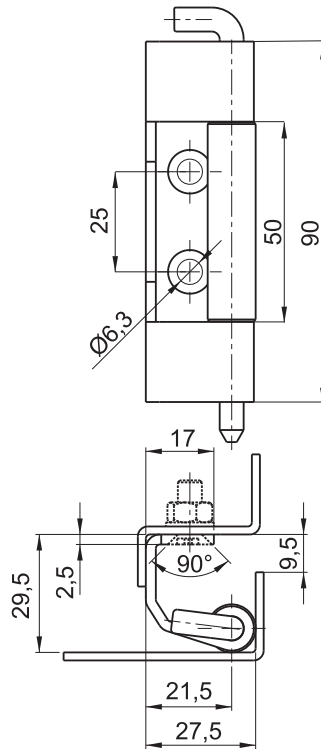

CATALOGUE NUMBER	COMPONENTS	MATERIAL
3.ST12-1.001	Base, Pin Holder	Steel zinc plated Steel
3.ST12-1.001SN	Holder, Base, Pin	Stainless steel

stainless steel

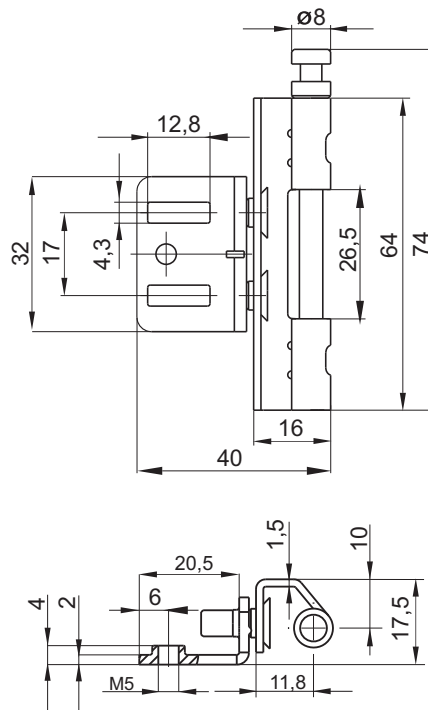

CATALOGUE NUMBER	COMPONENTS	MATERIAL
3.ST76.001	Holder, Base, Pin	Steel zinc plated
3.ST76.001SN	Holder, Base, Pin	Stainless steel

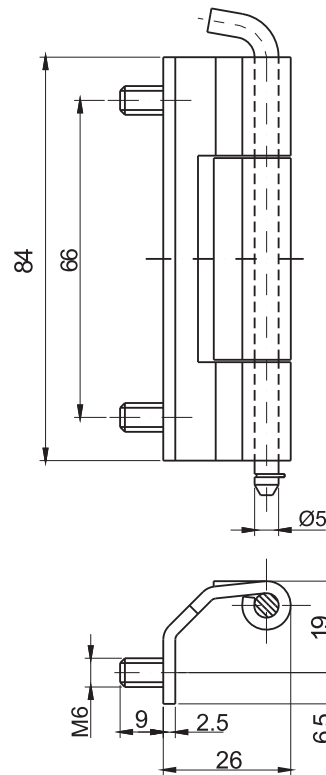

CATALOGUE NUMBER	COMPONENTS	MATERIAL
3.ST19-2.001	Base, Pin	Steel zinc plated
	Holder	Steel
3.ST19-2.001SN	Holder, Base, Pin	Stainless steel

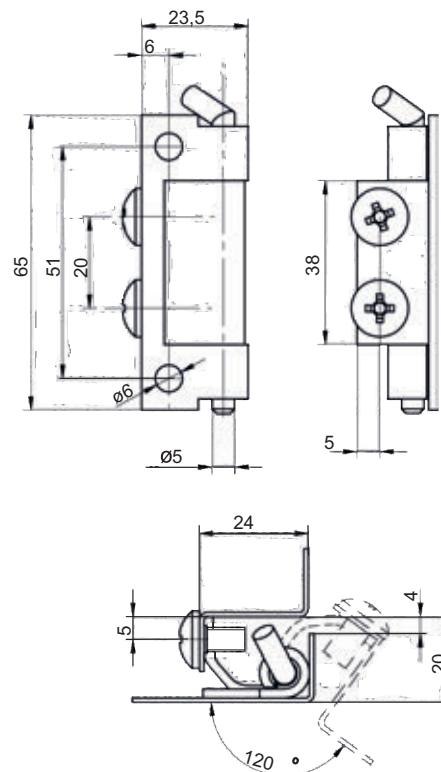

CATALOGUE NUMBER	COMPONENTS	MATERIAL
3.537.001	Holder, Base, Pin	Steel zinc plated
3.537.001SN	Holder, Base, Pin	Stainless steel

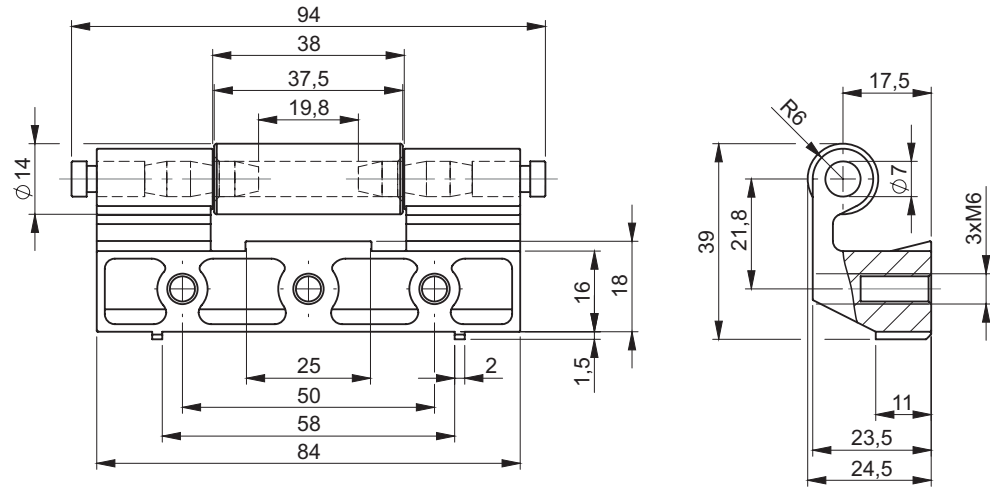

CATALOGUE NUMBER	COMPONENTS	MATERIAL	FINISH [C]
			RAL 9005
3.ST556.001	Holder	ZAMAK 5	04
	Base, Pin	Steel zinc plated	

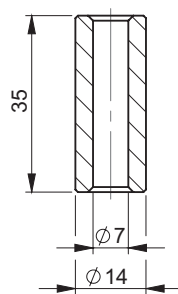
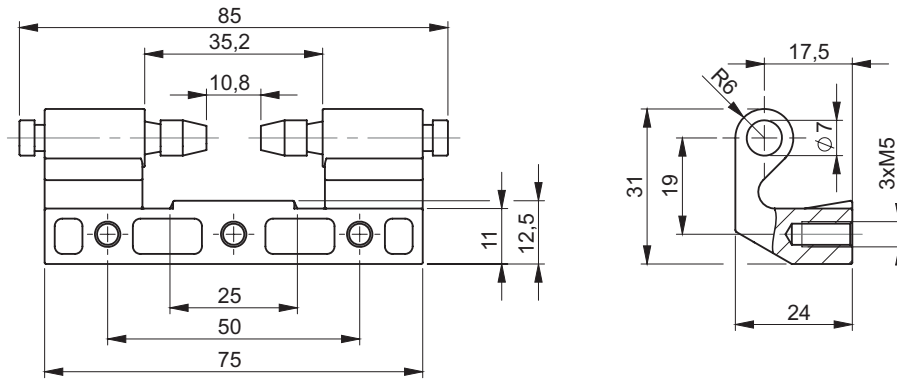

3.ST557.001

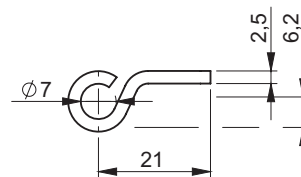
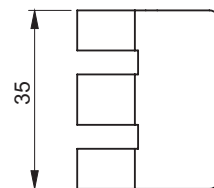

3.ST557.002

CATALOGUE NUMBER	DETAIL	COMPONENTS	MATERIAL	FINISH [C]
				RAL 9005
3.ST557.001	ver. with a bushing	Base	ZAMAK 5	04
3.ST557.002	ver. with a sheet metal	Holder, Pin	Steel zinc plated	

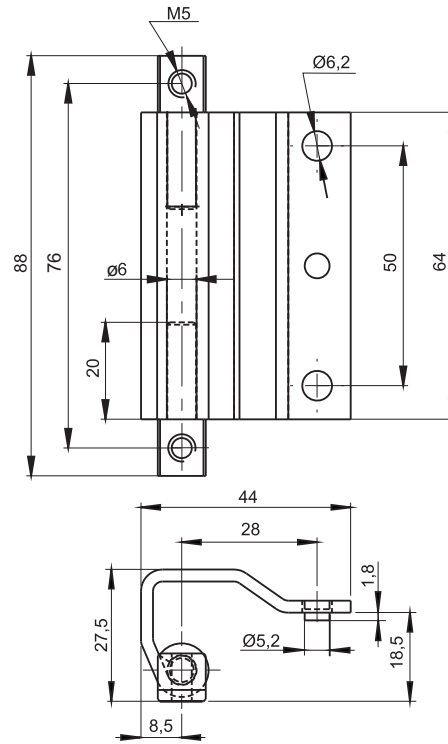

CATALOGUE NUMBER	COMPONENTS	MATERIAL
3.ST40.001	Holder, Base, Pin	Steel zinc plated
3.ST40.001SN	Holder, Base, Pin	Sainless steel

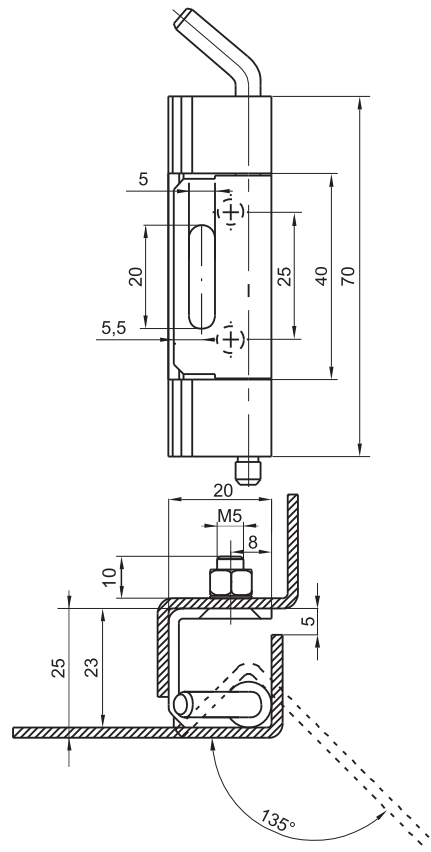

CATALOGUE NUMBER	COMPONENTS	MATERIAL
3.ST41.001	Base, Pin	Steel zinc plated
	Holder	Steel
3.ST41.001SN	Holder, Base, Pin	Sainless steel



stainless steel

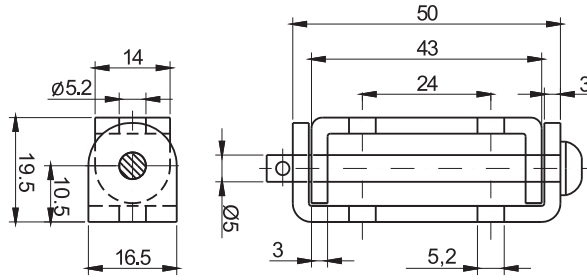

CATALOGUE NUMBER	COMPONENTS	MATERIAL
3.ST10.001	Holder, Base, Pin	Steel zinc plated
3.ST10.001SN	Holder, Base, Pin	Stainless steel



stainless steel

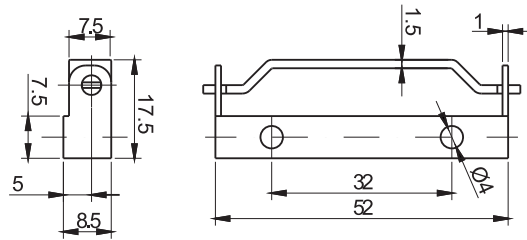

CATALOGUE NUMBER	COMPONENTS	MATERIAL
3.ST11.001	Base, Pin	Steel zinc plated
	Holder	Steel
3.ST11.001SN	Holder, Base, Pin	Sainless steel



stainless steel

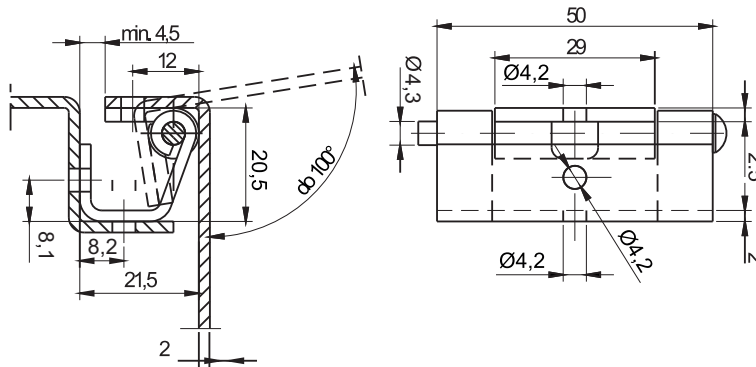

CATALOGUE NUMBER	COMPONENTS	MATERIAL
3.ST14.001	Holder, Base, Pin	Steel zinc plated
3.ST14.001SN	Holder, Base, Pin	Sainless steel



stainless steel

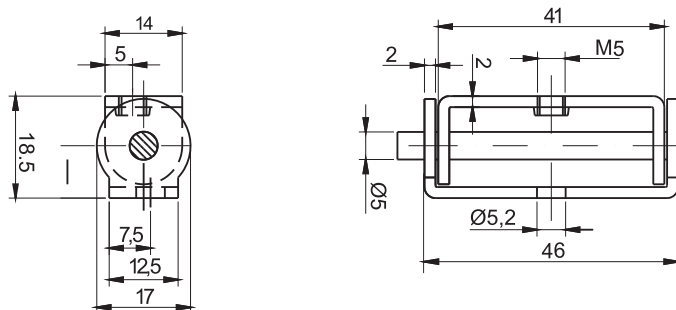

CATALOGUE NUMBER	COMPONENTS	MATERIAL
3.ST15.001	Holder, Base, Pin	Steel zinc plated
3.ST15.001SN	Holder, Base, Pin	Sainless steel

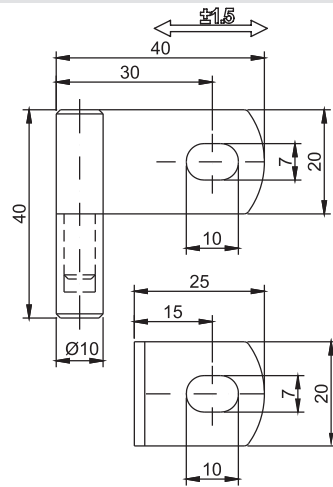

LEFT VERSION

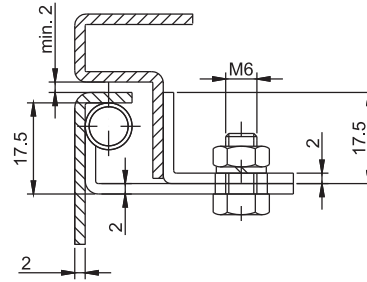

CATALOGUE NUMBER	COMPONENTS	MATERIAL
3.ST8.001	Fixed holder (screws)	Steel zinc plated
	Welded base	Steel
3.ST8.001SN	Holder, Base	Sainless steel

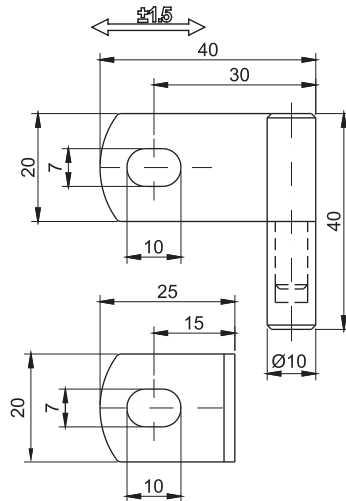

RIGHT VERSION

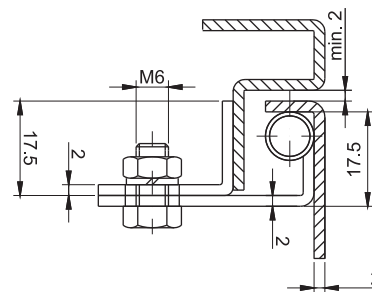

CATALOGUE NUMBER	COMPONENTS	MATERIAL
3.ST8.002	Fixed holder (screws)	Steel zinc plated
	Welded base	Steel
3.ST8.002SN	Holder, Base	Sainless steel

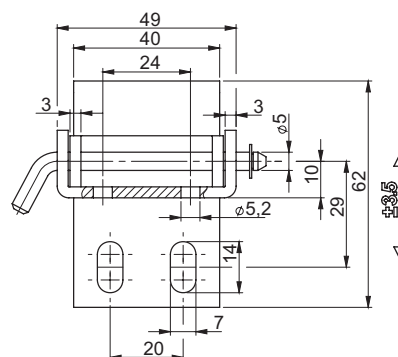
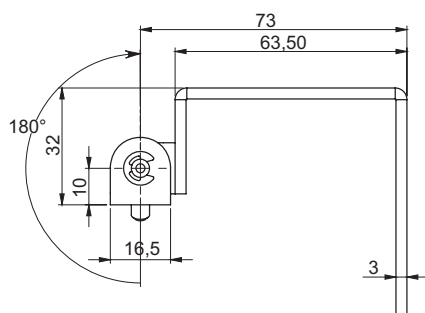

CATALOGUE NUMBER	COMPONENTS	MATERIAL
3.ST9.001	Holder, Base, Pin	Steel zinc plated
3.ST9.001SN	Holder, Base, Pin	Sainless steel

stainless steel

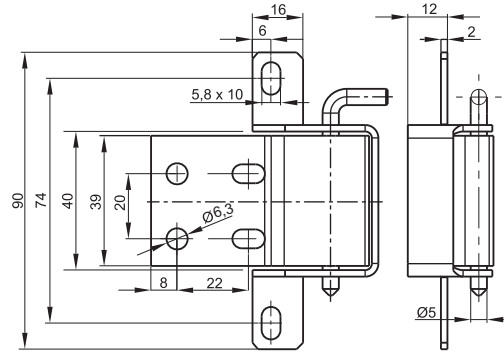
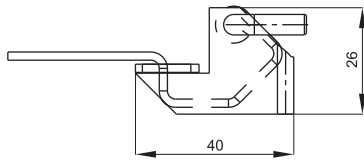

CATALOGUE NUMBER	COMPONENTS	MATERIAL
3.ST31.001	Holder, Base, Pin	Steel zinc plated
3.ST31.001SN	Holder, Base, Pin	Stainless steel

stainless steel

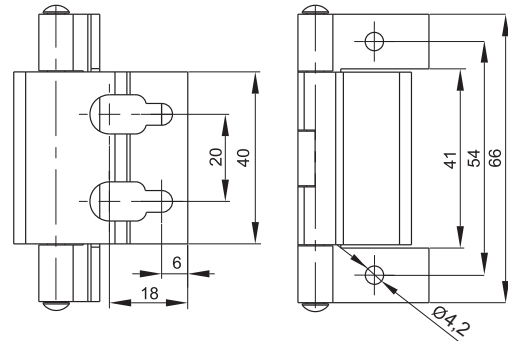
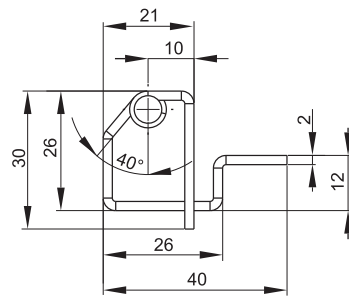
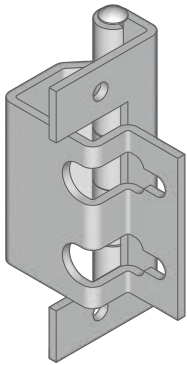

CATALOGUE NUMBER	COMPONENTS	MATERIAL
3.ST33.001	Holder, Base, Pin	Steel zinc plated
3.ST33.001SN	Holder, Base, Pin	Sainless steel

stainless steel

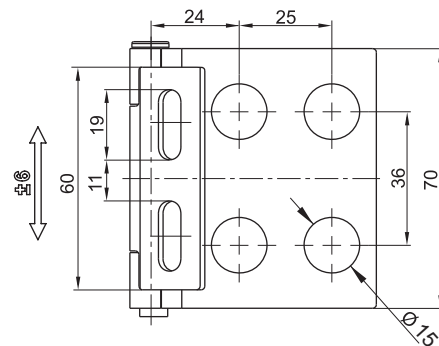
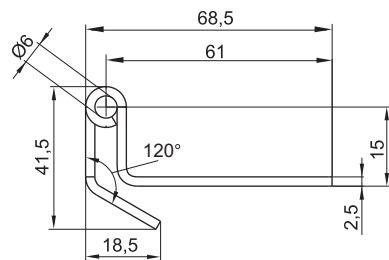
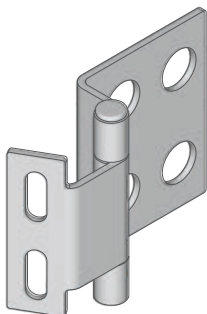

CATALOGUE NUMBER	COMPONENTS	MATERIAL
3.ST34.001	Holder, Base, Pin	Steel zinc plated
3.ST34.001SN	Holder, Base, Pin	Stainless steel

stainless steel

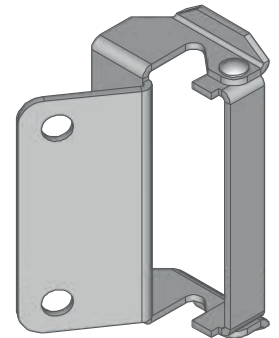
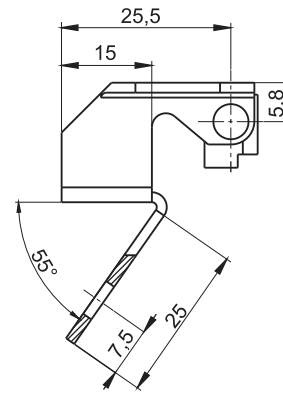
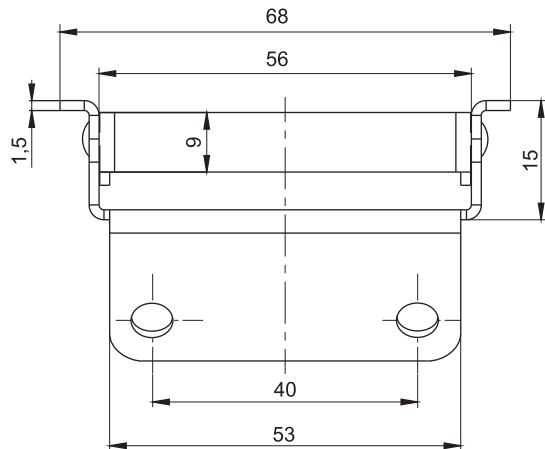

CATALOGUE NUMBER	COMPONENTS	MATERIAL
3.ST38.001	Holder, Base, Pin	Steel zinc plated
3.ST38.001SN	Holder, Base, Pin	Stainless steel

stainless steel

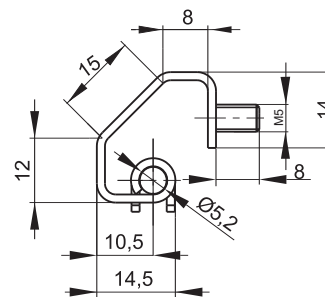
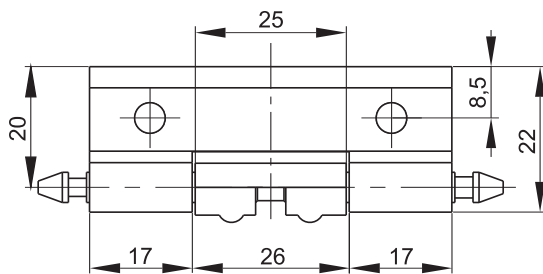

CATALOGUE NUMBER	COMPONENTS	MATERIAL
3.ST39.001	Base, Pin	Steel zinc plated
	Holder	Steel
3.ST39.001SN	Holder, Base, Pin	Stainless steel

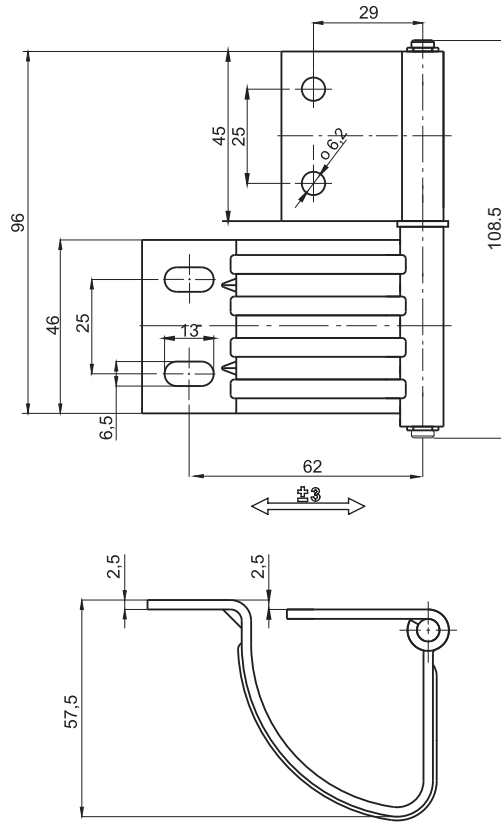

CATALOGUE NUMBER	COMPONENTS	MATERIAL
3.ST95.001	Holder, Base, Pin	Steel zinc plated
3.ST95.002SN	Holder, Base, Pin	Stainless steel

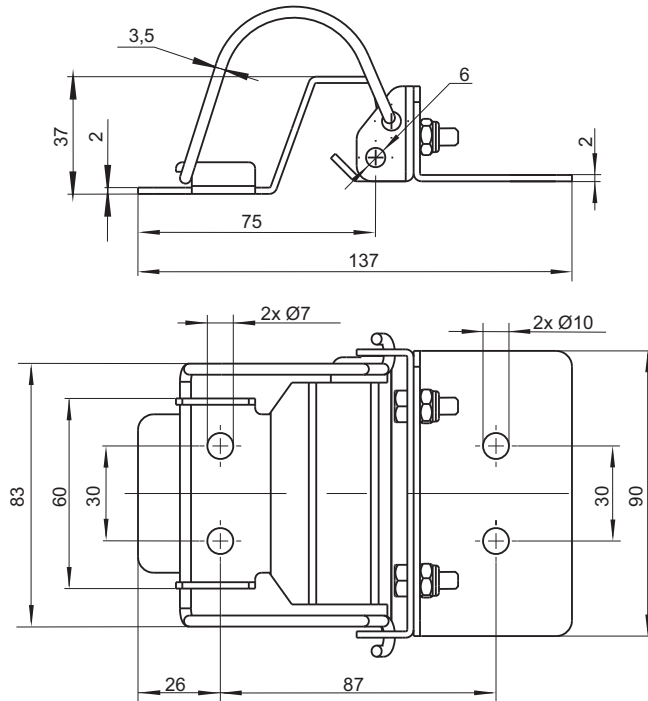
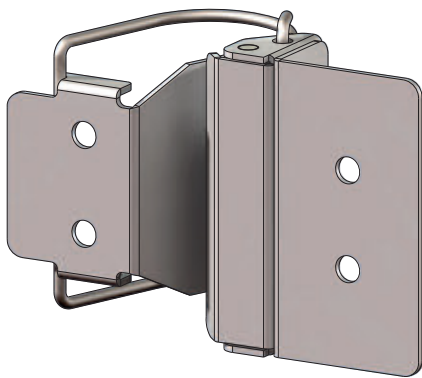

CATALOGUE NUMBER	MATERIAL
3.ST120.001SN	Stainless steel

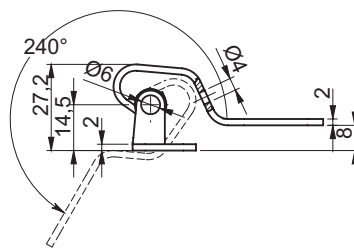

3.ST118.001

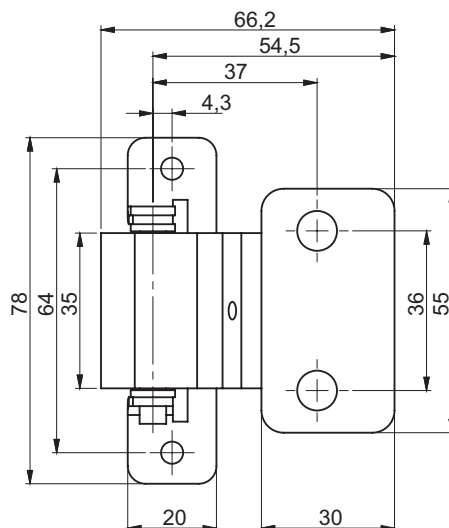

3.ST118.002

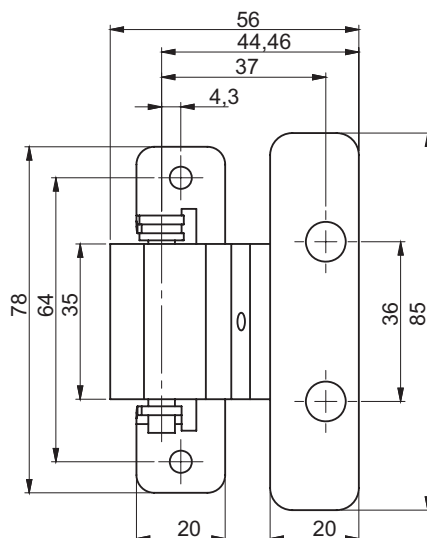

CATALOGUE NUMBER	COMPONENTS	MATERIAL	FINISH [C]
			RAL 9005
3.ST118.001	Holder, Base,	Steel zinc plated	04
	Pin	Stainless steel	
3.ST118.001SN	Holder, Base, Pin	Stainless steel	
3.ST118.002	Holder, Base	Steel zinc plated	
	Pin	Stainless steel	
3.ST118.002SN	Holder, Base, Pin	Stainless steel	

A - slide bushings made of plastics (POM)

stainless steel

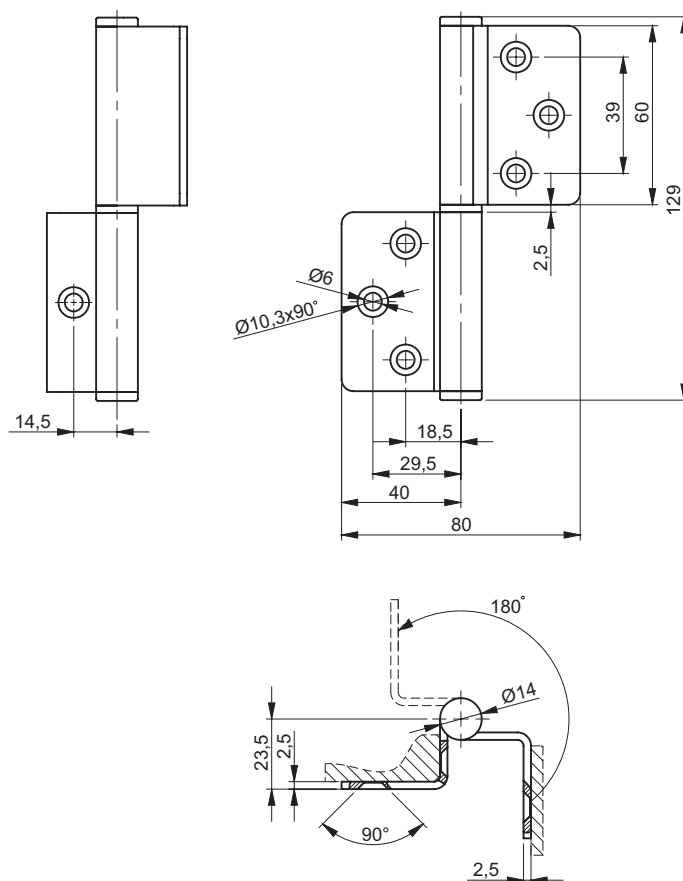

CATALOGUE NUMBER	COMPONENTS	MATERIAL
3.ST121.001	Holder, Base, Pin	Steel zinc plated
3.ST121.001SN	Holder, Base, Pin	Stainless steel

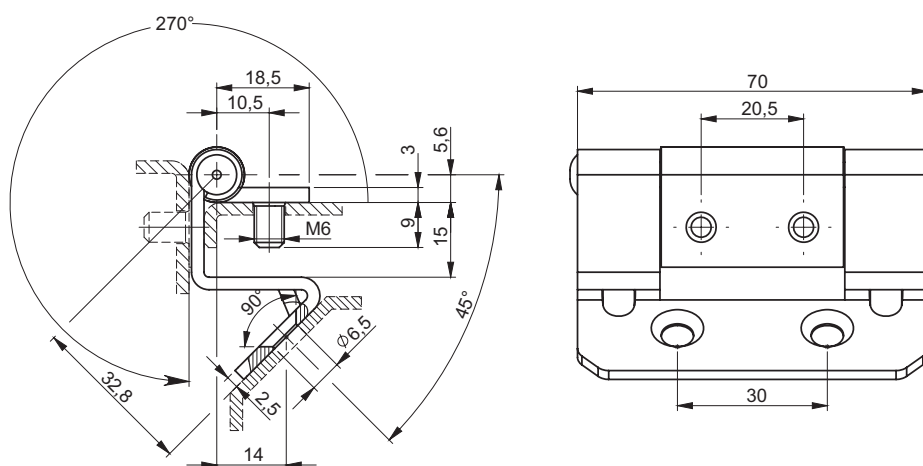

CATALOGUE NUMBER	COMPONENTS	MATERIAL
3.ST119.001	Holder, Base	Steel zinc plated
	Pin	Stainless steel

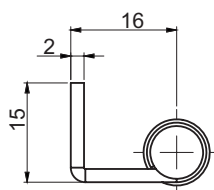
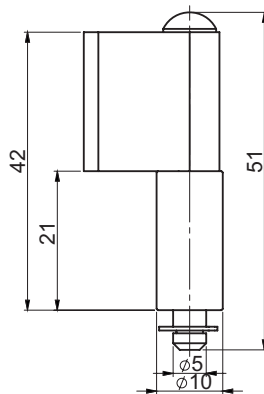

CATALOGUE NUMBER	COMPONENTS	MATERIAL
3.ST105.001	Holder, Base	Steel
	Pin	Steel zinc plated

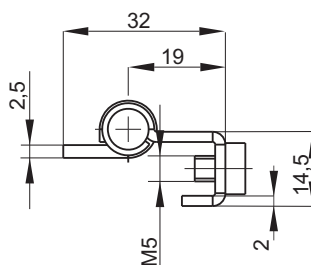
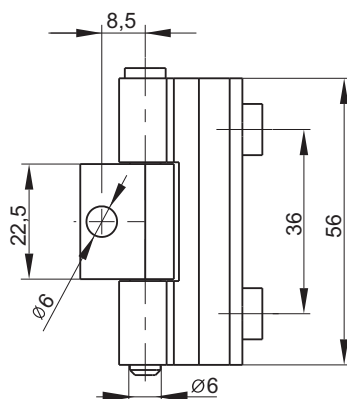

Two screws in the set DIN 7985 M5x6

CATALOGUE NUMBER	COMPONENTS	MATERIAL
3.ST112.001	Base, Pin	Steel zinc plated
	Holder	Copper-clad steel

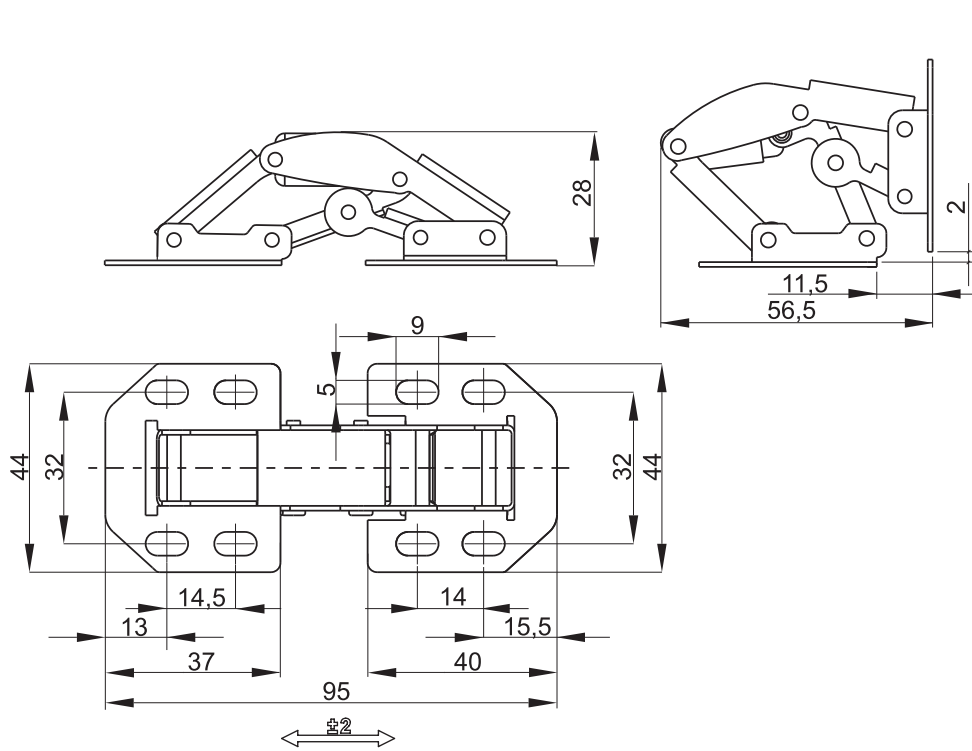

CATALOGUE NUMBER	COMPONENTS	MATERIAL
3.ST100.001	Base, Pin, Rivet	Steel zinc plated
3.ST100.001SN	Base, Pin, Rivet	Stainless steel

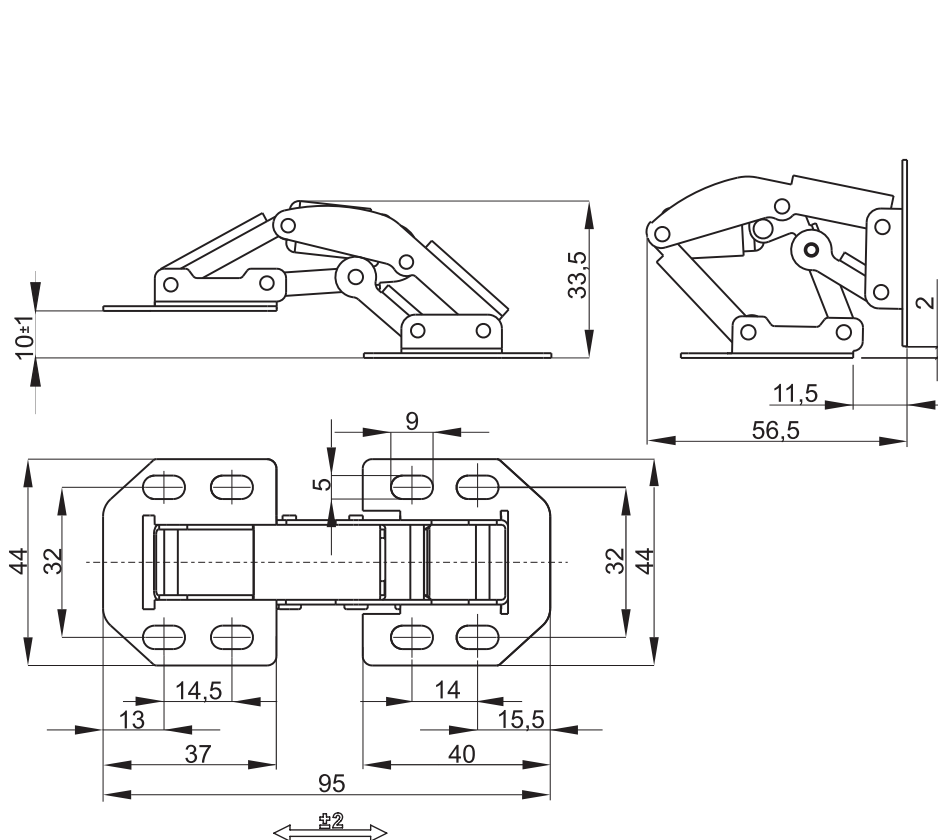

CATALOGUE NUMBER	COMPONENTS	MATERIAL
3.ST100.002	Base, Pin, Rivet	Steel zinc plated
3.ST100.002SN	Base, Pin, Rivet	Stainless steel

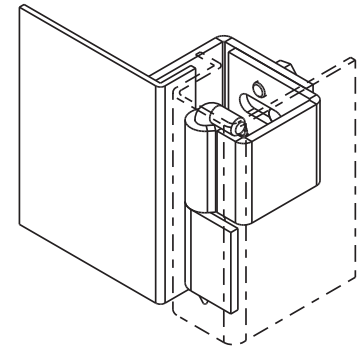
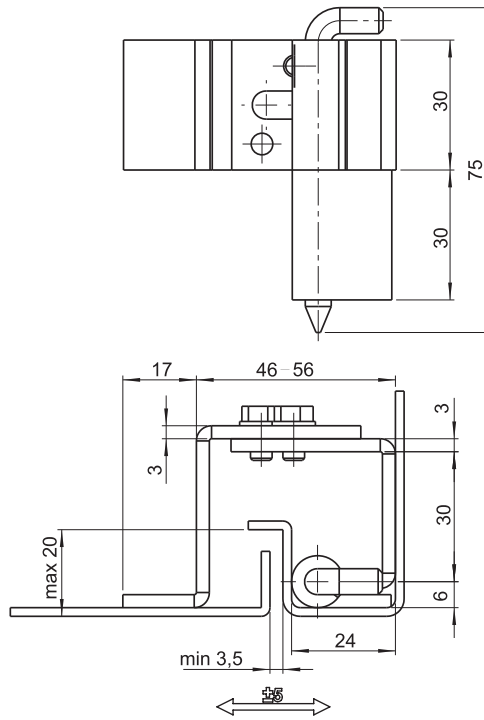

CATALOGUE NUMBER	COMPONENTS	MATERIAL
3.ST46.001	Holder, Pin	Steel zinc plated
	Base	Steel
3.ST46.001SN	Holder, Base, Pin	Stainless steel

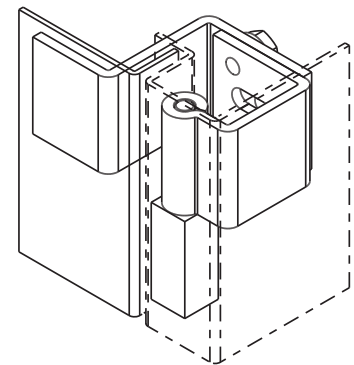
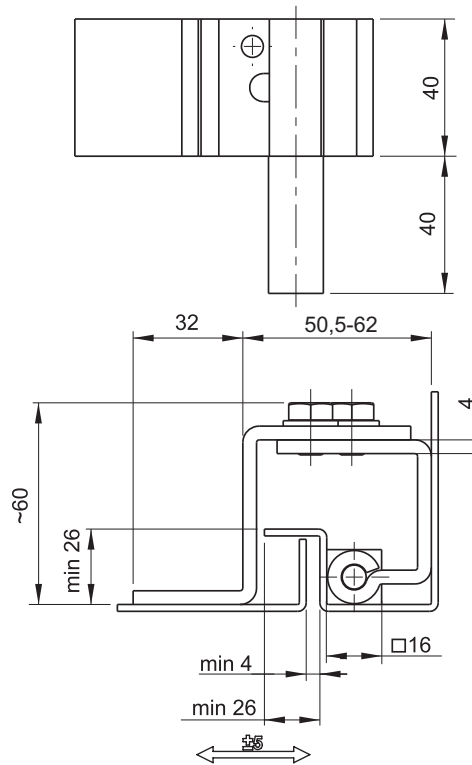

CATALOGUE NUMBER	COMPONENTS	MATERIAL
3.ST46-2.001	Holder	Steel
	Base	Steel zinc plated
3.ST46-2.001SN	Holder, Base, Pin	Stainless steel

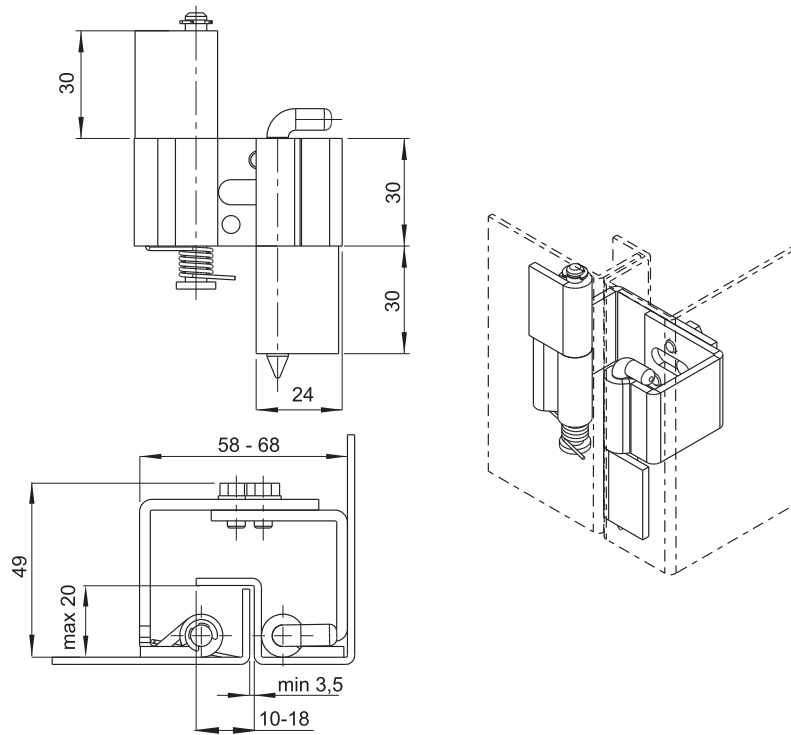

CATALOGUE NUMBER	COMPONENTS	MATERIAL
3.ST46-3.002	Holder, Pin	Steel zinc plated
	Base	Steel zinc plated
3.ST46-3.002SN	Holder, Base, Pin	Stainless steel

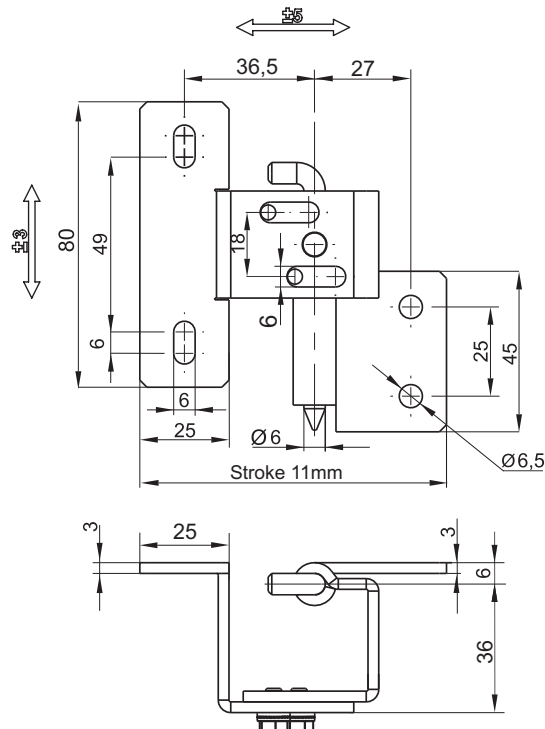

CATALOGUE NUMBER	COMPONENTS	MATERIAL
3.ST46-4.001	Holder, Base, Pin	Steel zinc plated
3.ST46-4.001SN	Holder, Base, Pin	Stainless steel

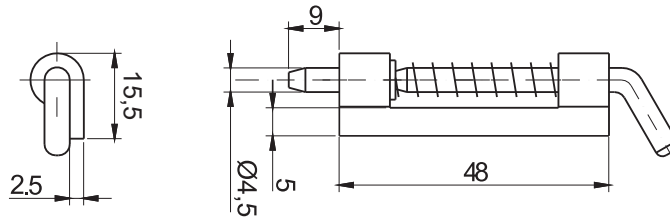

CATALOGUE NUMBER	COMPONENTS	MATERIAL
3.ST20.001	Holder	Steel
	Pin, Spring	Steel zinc plated
	Spring	Stainless steel
3.ST20.001SN	Holder, Pin, Spring	Stainless steel

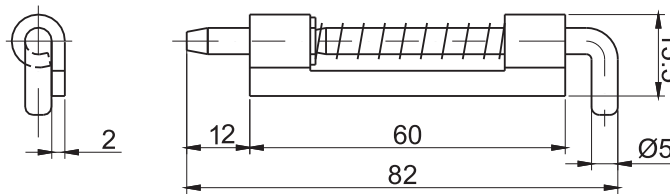

CATALOGUE NUMBER	COMPONENTS	MATERIAL
3.ST20.002	Holder	Steel
	Pin, Spring	Steel zinc plated
3.ST20.002SN	Holder, Pin, Spring	Stainless steel

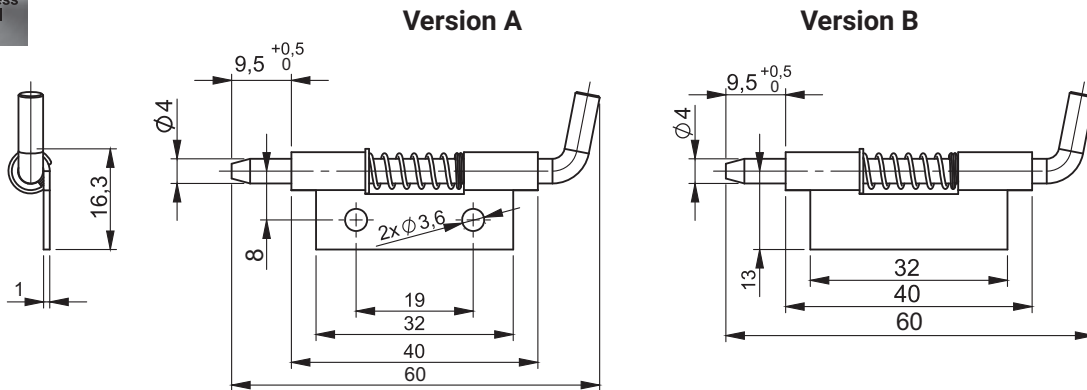

CATALOGUE NUMBER	VERSION	COMPONENTS	MATERIAL
3.ST20.003	A	Holder, Pin, Spring	Steel zinc plated
		Spring	Stainless steel
3.ST20.003SN	A	Holder, Pin, Spring	Stainless steel
3.ST20.003	B	Holder	Steel
		Pin	Steel zinc plated
		Spring	Stainless steel
3.ST20.003SN	B	Holder, Pin, Spring	Stainless steel

How to order:

Catalogue number

Version

3.ST20.003 — A

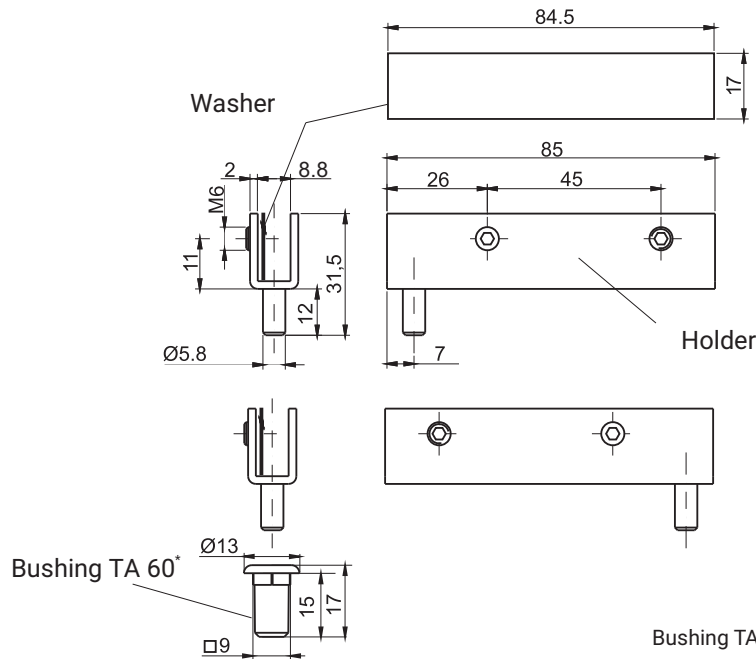

3.ST24.001 - right version
3.ST24.002 - left version

Bushing TA60 (pg. 3B-32) ordered separately.

CATALOGUE NUMBER	COMPONENTS	MATERIAL	FINISH [C]	
			RAL9005	RAL7035
3.ST24.001	Holder	Steel zinc plated	04	05
	Washer	Brass		
3.ST24.002	Holder	Steel zinc plated		
	Washer	Brass		

* to special order

** possibility to make a different color

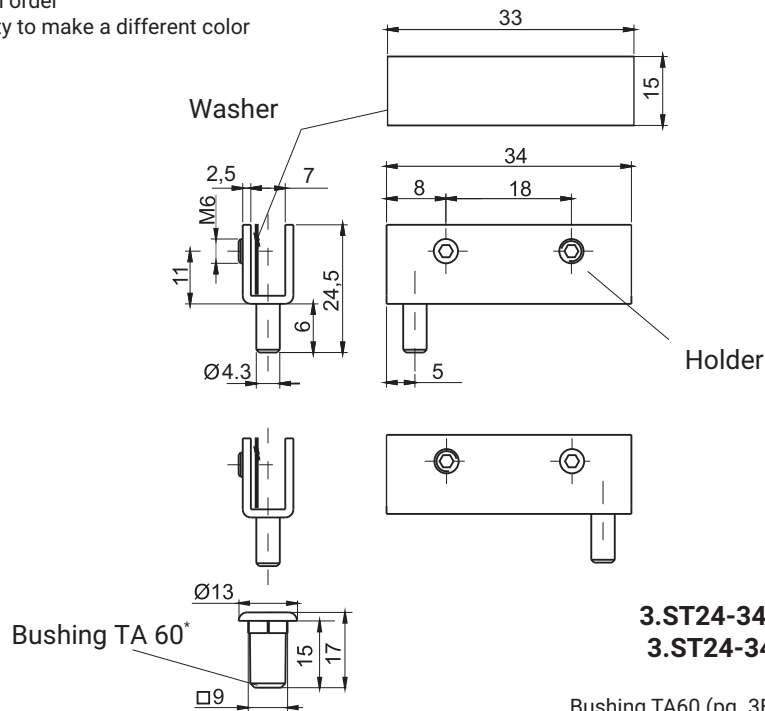

3.ST24-34.001 - right version
3.ST24-34.002 - left version

Bushing TA60 (pg. 3B-323) ordered separately.

CATALOGUE NUMBER	COMPONENTS	MATERIAL	FINISH [C]	
			RAL9005	RAL7035
3.ST24-34.001	Holder	Steel zinc plated	04	05
	Washer	Brass		
3.ST24-34.002	Holder	Steel zinc plated		
	Washer	Brass		

* to special order, ** possibility to make a different color

How to order:

Catalogue number

Finish

3.ST24.001 — C



stainless steel

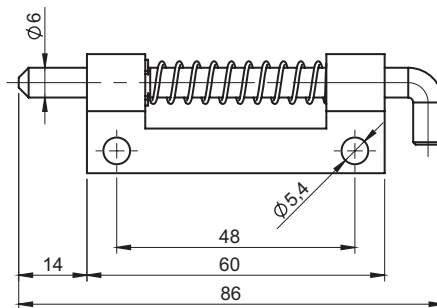
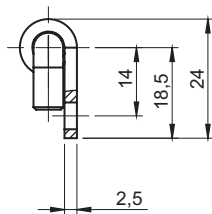

CATALOGUE NUMBER	COMPONENTS	MATERIAL
3.ST20.004	Holder, Pin	Steel zinc plated
3.ST20.004SN	Holder, Pin	Stainless steel



stainless steel

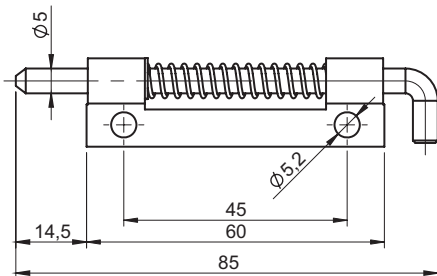
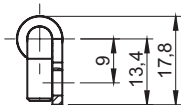

CATALOGUE NUMBER	COMPONENTS	MATERIAL
3.ST20.005	Holder, Pin	Steel zinc plated
3.ST20.005SN	Holder, Pin	Stainless steel



stainless steel

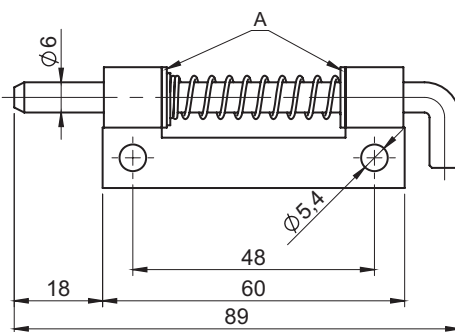
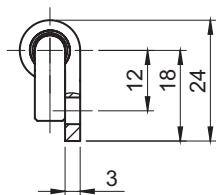

A - slide bushings made of plastics

CATALOGUE NUMBER	COMPONENTS	MATERIAL
3.ST20.010	Holder, Pin	Steel zinc plated
	Plain bearing bush	POM
3.ST20.010SN	Holder, Pin	Stainless steel

Hinge 3.ST60, 3.ST65



ROZTOCZE

3B

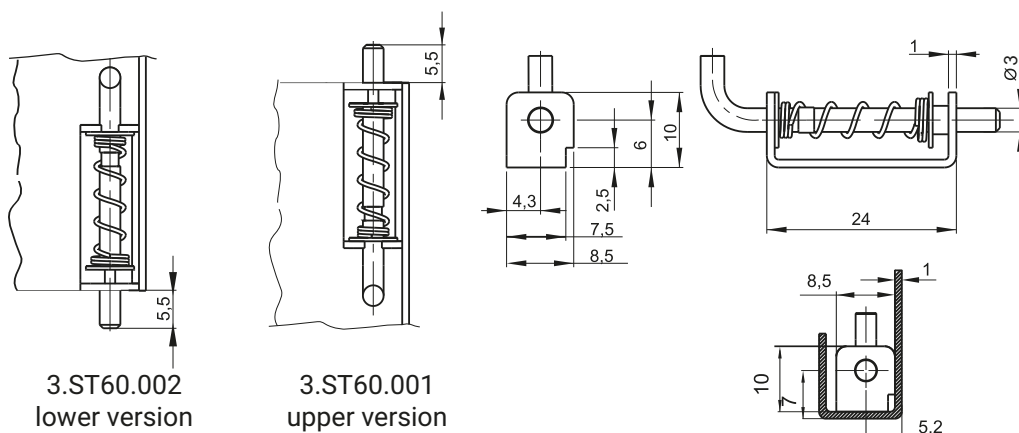

3.ST60.002
lower version

3.ST60.001
upper version



CATALOGUE NUMBER	COMPONENTS	MATERIAL
3.ST60.001	Holder	Steel
3.ST60.002	Pin	Steel zinc plated

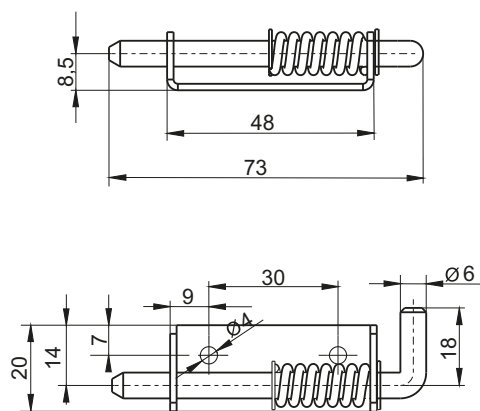

CATALOGUE NUMBER	COMPONENTS	MATERIAL
3.ST60.003	Holder, Pin	Steel zinc plated
3.ST60.004	Holder, Pin	Steel zinc plated

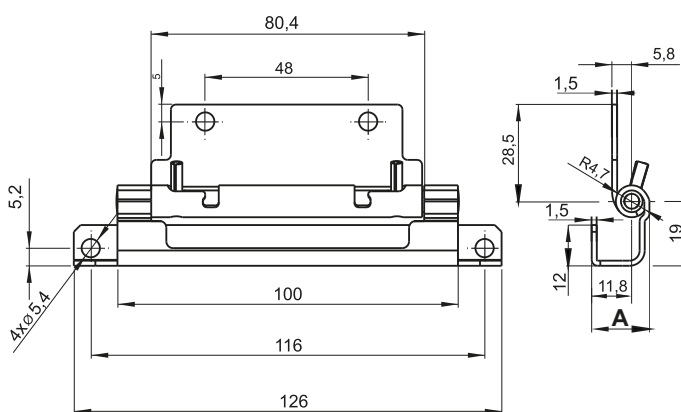

stainless steel



CATALOGUE NUMBER	DIMENSIONS A [mm]	COMPONENTS	MATERIAL
3.ST65.001	17	Holder, Base, Pin	Steel zinc plated
3.ST65.002	20		
3.ST65.003	23,4		
3.ST65.001SN	17	Holder, Base, Pin	Stainless steel
3.ST65.002SN	20		
3.ST65.003SN	23,4		

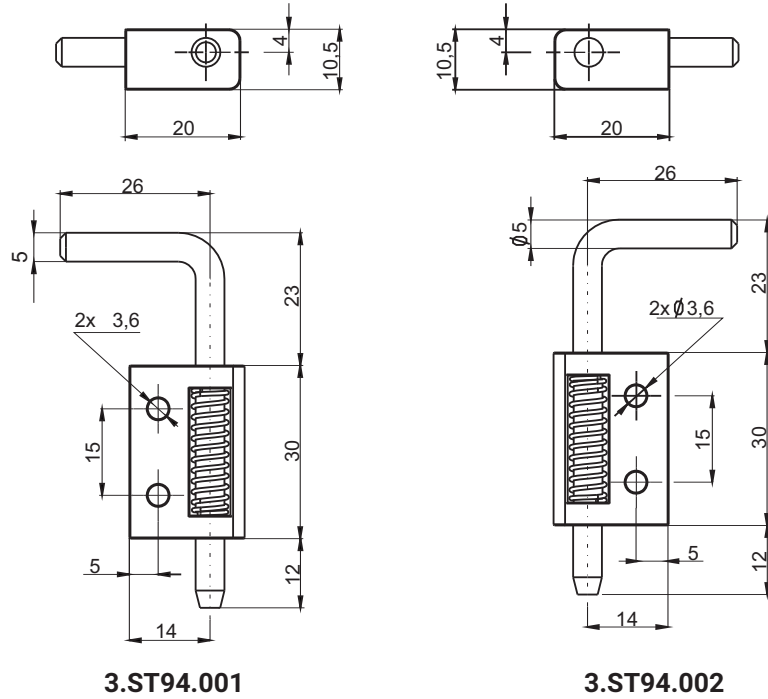

CATALOGUE NUMBER	COMPONENTS	MATERIAL	FINISH [C]
			RAL9005
3.ST94.001	Holder	Polyamide	07
3.ST94.002	Pin	Steel zinc plated	

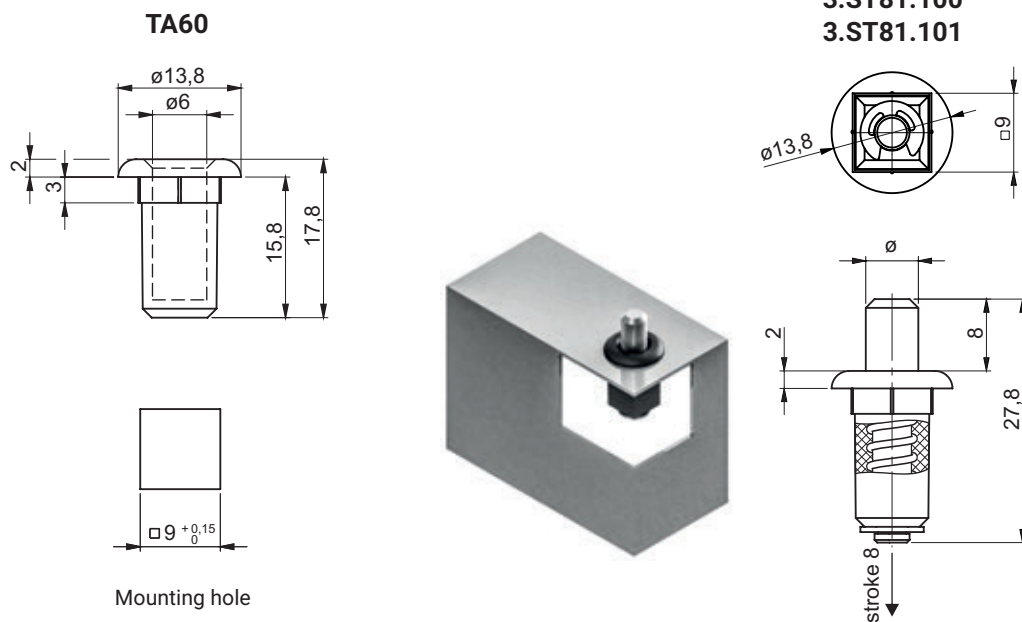

CATALOGUE NUMBER	ø [mm]	COMPONENTS	MATERIAL	FINISH [C]
				RAL9005
3.ST81.100	6	Housing	Polyamide PA6	07
3.ST81.101	5	Pin	Steel zinc plated	
TA60	6	Bushing	Polyamide PA6	

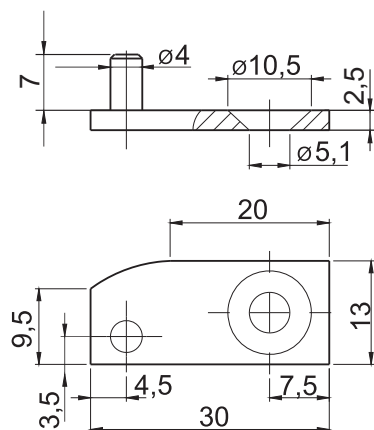

CATALOGUE NUMBER	COMPONENTS	MATERIAL
3.ST67.001	Holder	Steel zinc plated

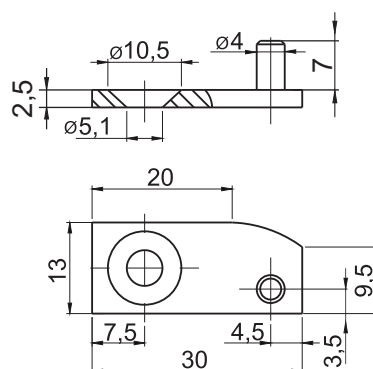

CATALOGUE NUMBER	COMPONENTS	MATERIAL
3.ST67.002	Holder	Steel zinc plated

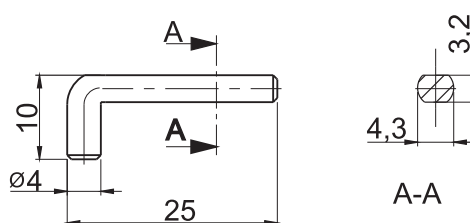

CATALOGUE NUMBER	COMPONENTS	MATERIAL
3.ST67.001.03	Pin	Steel

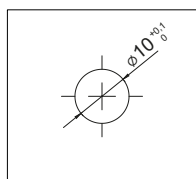
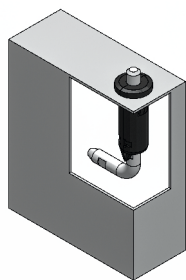

Mounting hole

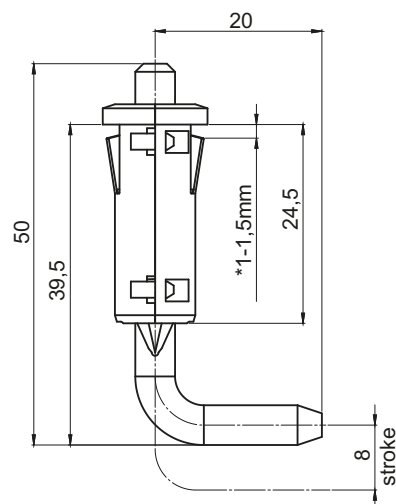
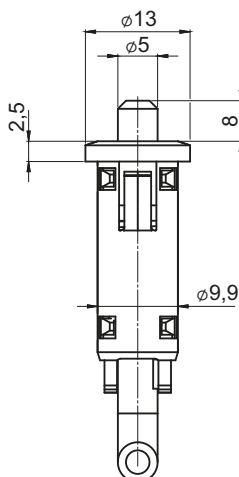

CATALOGUE NO.	COMPONENTS	MATERIAL	FINISH [C]	
			RAL 9005	RAL 9010
3.ST81.001	Housing	Polyamide		
	Pin	ZAMAK 5	07	11
	Spring	Steel		

How to order:

Catalogue number
Finish

3.ST81.001 — C

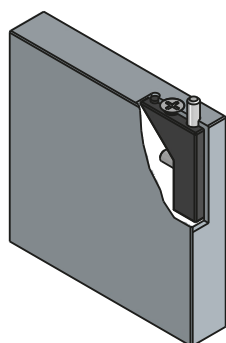

Screw acc. to
DIN 7982 ($\phi 2,9 \times 10$)

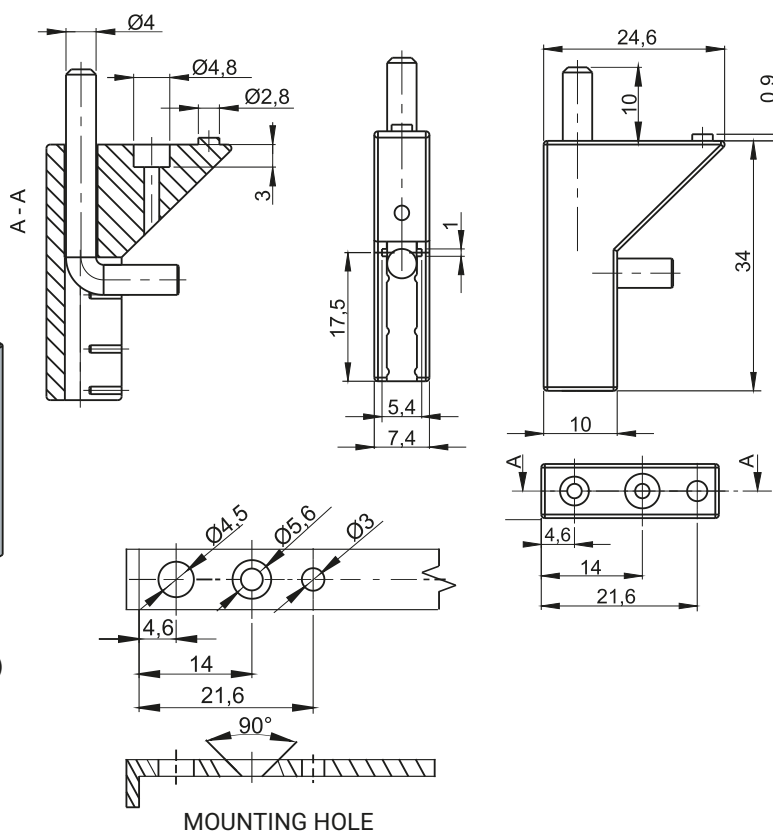

CATALOGUE NUMBER	COMPONENTS	MATERIAL	FINISH [C]
			RAL 9005
3.ST84.001	Holder	Polyamide	07
	Pin	Steel zinc plated	

3.ST96.001

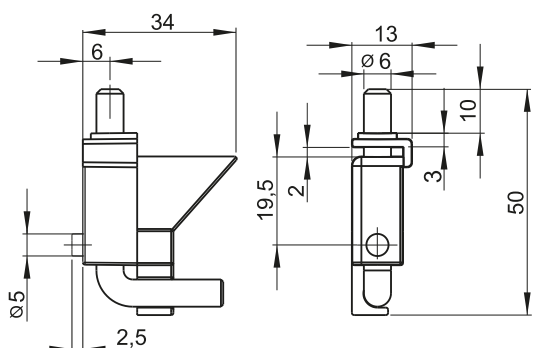

3.ST96.002

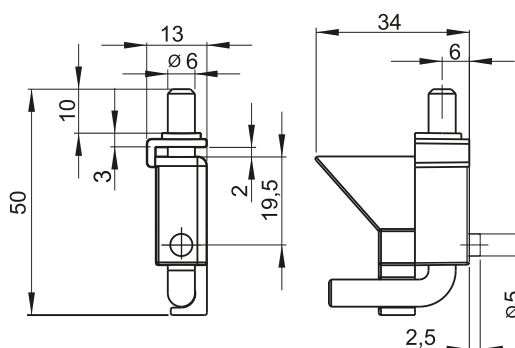

3.ST96.003

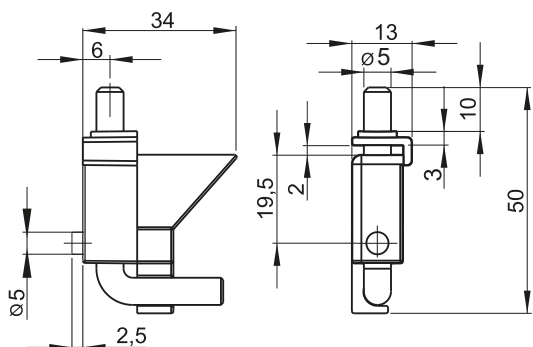

3.ST96.004

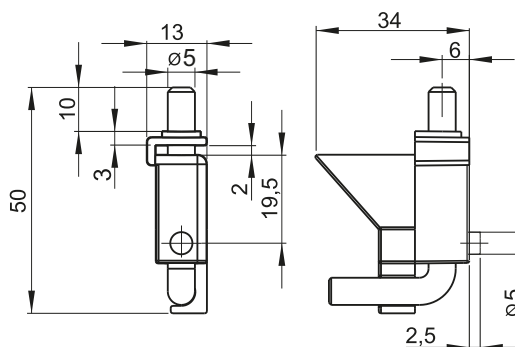

Mounting holes

**3.ST96.001
3.ST96.002**

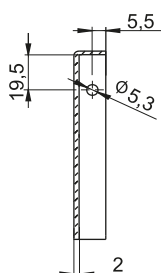

**3.ST96.003
3.ST96.004**

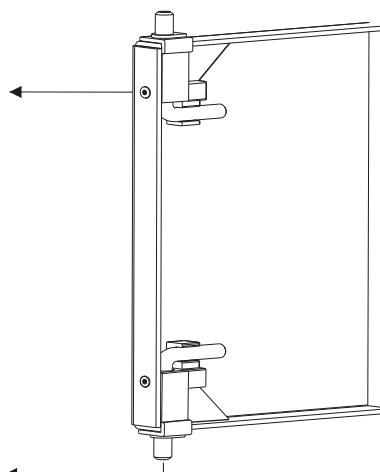
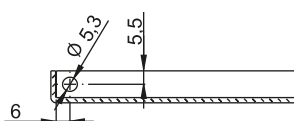
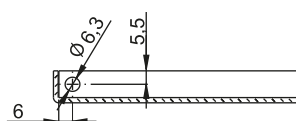
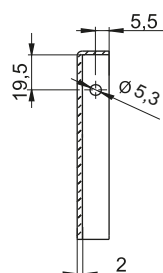

CATALOGUE NUMBER	COMPONENTS	MATERIAL	FINISH [C]	
			RAL9005	RAL7035
3.ST96.001	Holder	PP		
3.ST96.002	Pin	Steel zinc plated	07	08
3.ST96.003	Holder	PP		
3.ST96.004	Pin	Steel zinc plated	07	08

How to order:

Catalogue number

Finish

3.ST96.001 — C

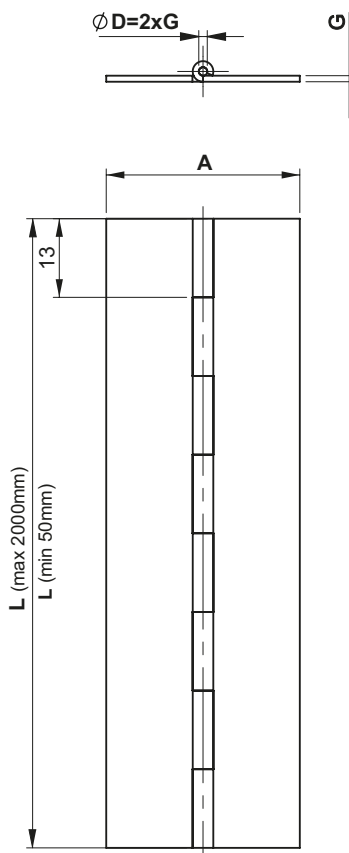

Standard insert diameter D for chosen thickness	
Sheet metal thickness G	Insert diameter D
0,8	Ø2
1	Ø1,5 or Ø2
1,5	Ø3, Ø4
2	Ø4, Ø6
3	Ø6

CATALOGUE NUMBER	COMPONENTS	MATERIAL
3.ST26.001	Holder, Pin	Steel zinc plated
3.ST26.001SN		Stainless steel

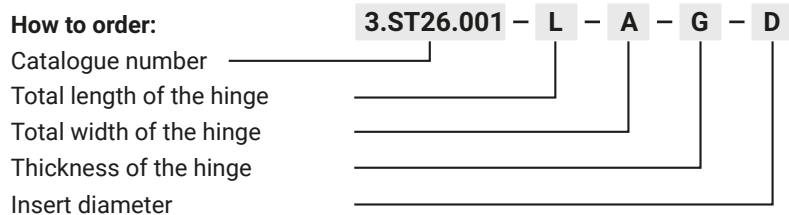

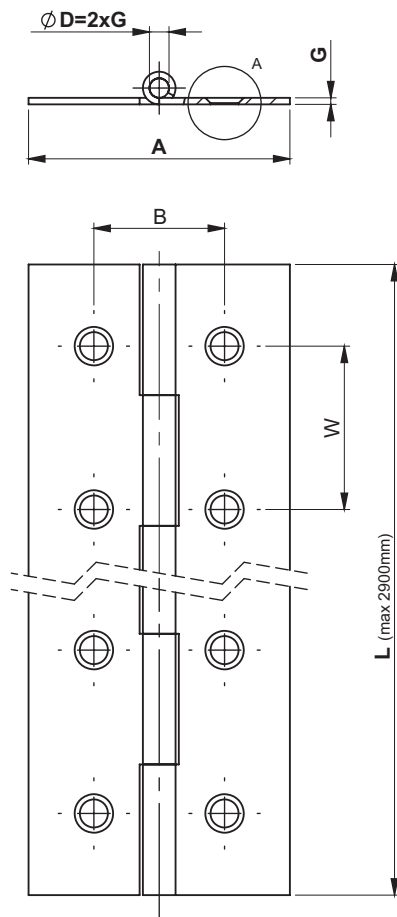

DETAIL A
SCALE 5 : 1

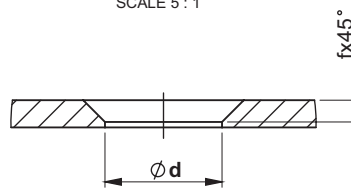

Standard insert diameter D for chosen thickness	
Sheet metal thickness G	Insert diameter D
0,8	Ø2
1	Ø2
1,5	Ø3, Ø4
2	Ø4, Ø6
3	Ø6

CATALOGUE NUMBER	COMPONENTS	MATERIAL
3.ST26.003	Holder, Pin	Steel zinc plated
3.ST26.003SN		Stainless steel

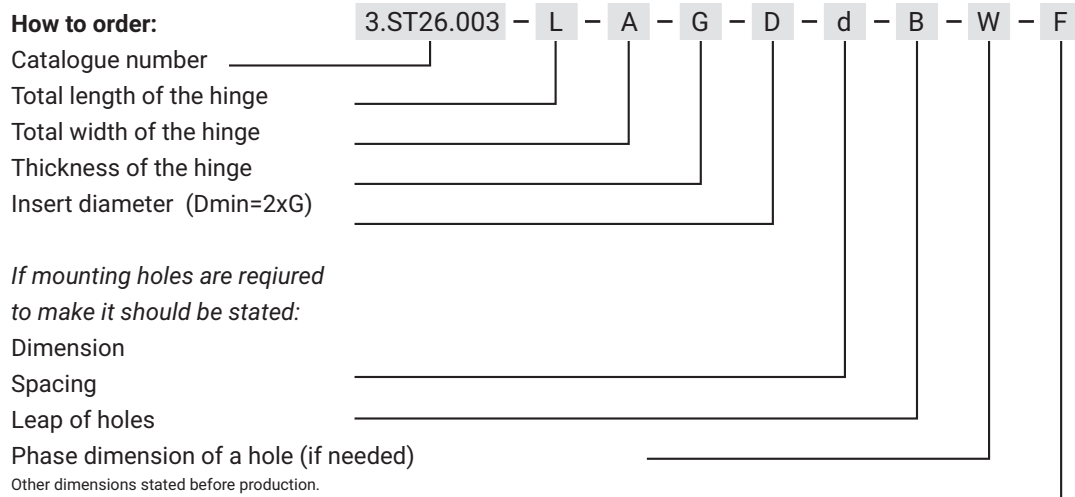

stainless
steel

3.ST50.001



3.ST50.002



3.ST50.003



3.ST50.004

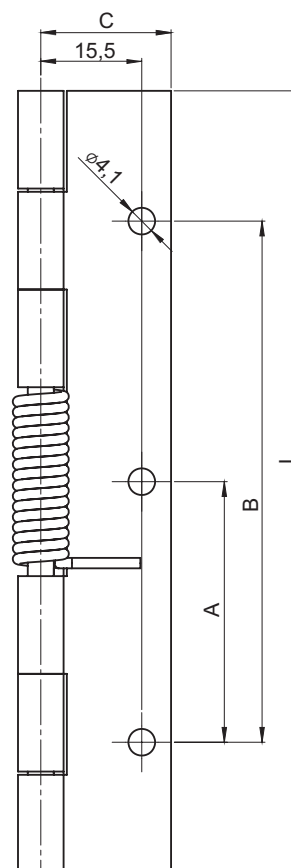
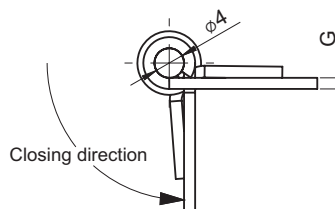

*closing from axis

CATALOGUE NUMBER	DIMENSION					MATERIAL
	A	B	C	G	L	
3.ST50.001	30	-	25	2	50	Steel zinc plated
3.ST50.002	40	80	20	1,5	120	
3.ST50.003	60	120	20	1,5	180	
3.ST50.004	-	-	20	1,5	120	
3.ST50.001SN	30	-	25	2	50	Stainless steel
3.ST50.002SN	40	80	20	1,5	120	
3.ST50.003SN	60	120	20	1,5	180	
3.ST50.004SN	-	-	20	1,5	120	

Left hinge
3.ST79.002

Right hinge
3.ST79.001

stainless steel

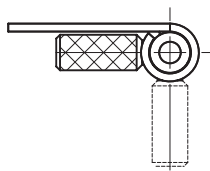
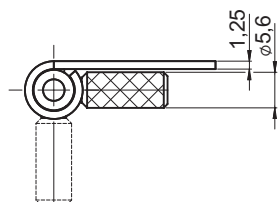
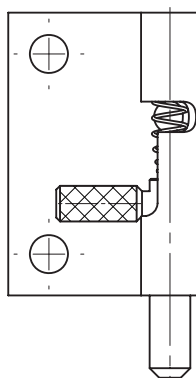
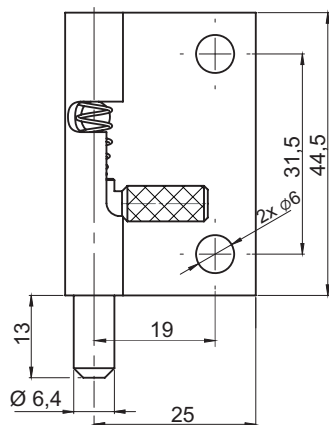

CATALOGUE NO.	VERSION	COMPONENTS	MATERIAL
3.ST79.001SN	Right	Holder, Pin	Stainless steel
3.ST79.002SN	Left	Holder, Pin	

Left hinge
3.ST104.006.002

Right hinge
3.ST104.006.001

stainless steel x

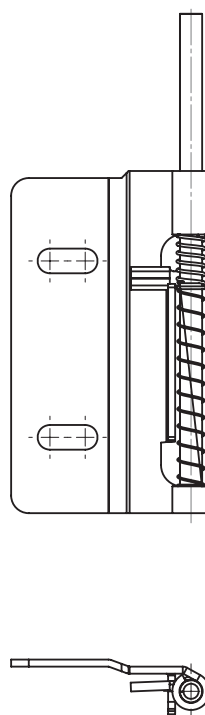
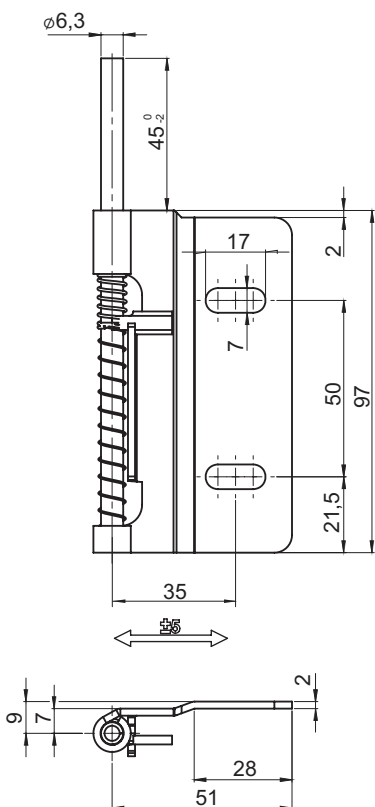

CATALOGUE NO.	VERSION	COMPONENTS	MATERIAL
3.ST104.006.001SN	Right	Holder, Pin	Stainless steel
3.ST104.006.002SN	Left		

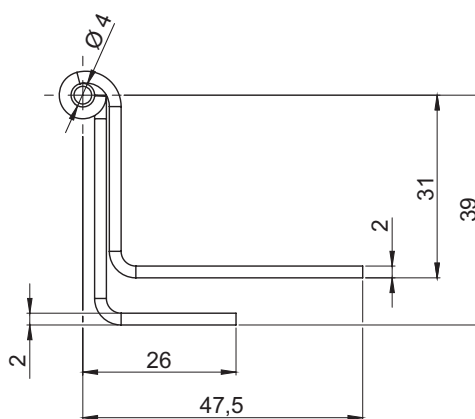
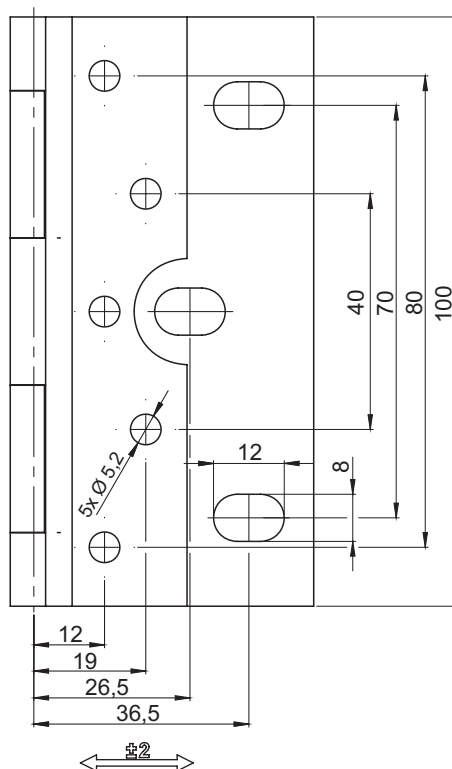

CATALOGUE NO.	COMPONENTS	MATERIAL
3.ST89.001SN	Holder, Base, Pin	Stainless steel

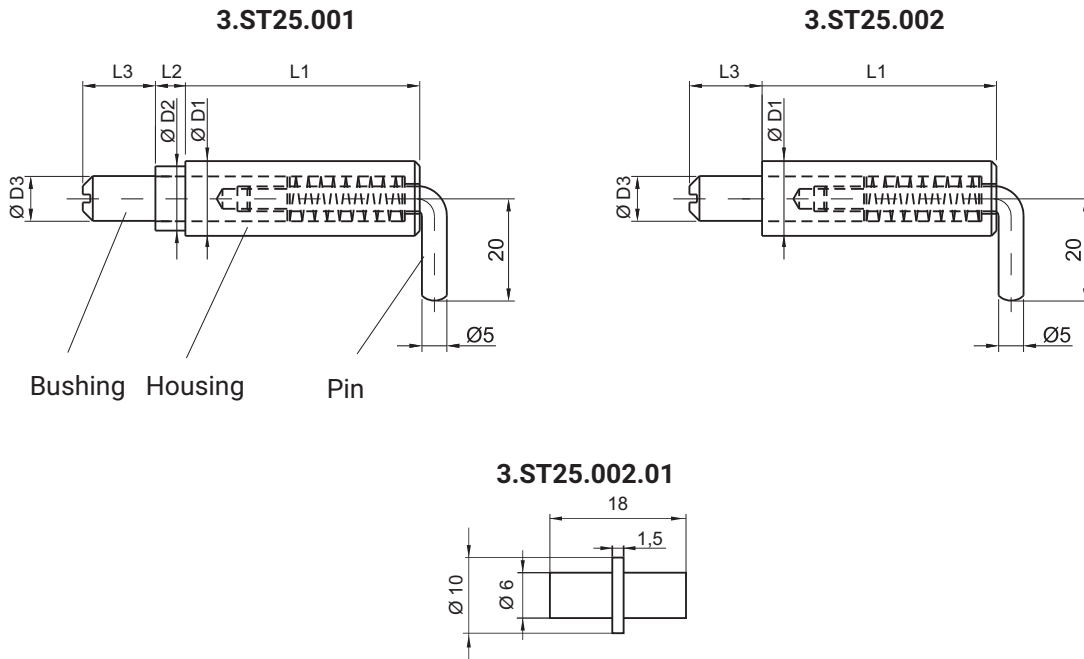

CATALOGUE NUMBER	Ø D1	Ø D2	Ø D3	L1 mm	L2 mm	L3 mm	COMPONENTS	MATERIAL
3.ST25.001	15	13	9	47	6	15	Housing, Bushing	Steel zinc plated
Pin								
3.ST25.001SN							Housing, Bushing	Stainless steel
							Pin	
3.ST25.002	10	-	6	41,5	-	13	Housing, Bushing	Steel zinc plated
							Pin	
3.ST25.002.01	-						Limiters	Steel without finish
3.ST25.005	12	9	6	38	3,5	10	Housing	Steel copper plated
							Bushing	Steel zinc plated



LH/RH

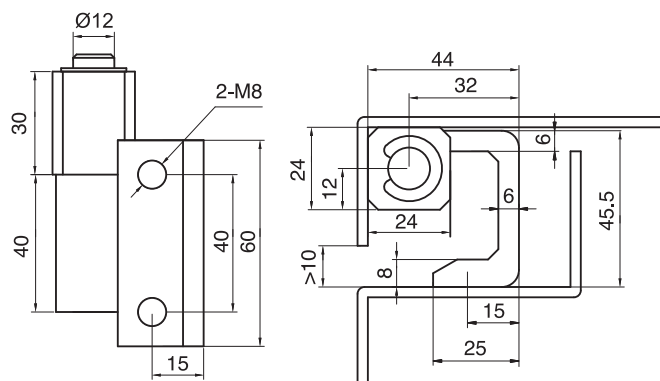

CATALOGUE NUMBER	COMPONENTS	MATERIAL
3.550.001	Holder, Pin	Stainless steel

stainless steel

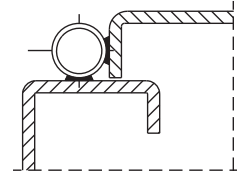
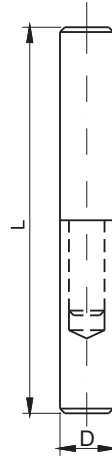
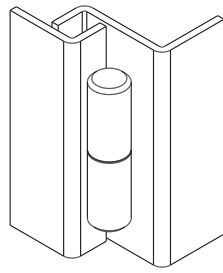

CATALOGUE NUMBER	Dimension		X
	L [mm]	D [mm]	
3.ST7.X 3.ST7.XSN	40	10	001
	50	10	002
	65	10	003
	40	14	005
	100	13	006
	100	16	007

CATALOGUE NUMBER	COMPONENTS	MATERIAL
3.ST7.X	Holder, Pin	Steel
3.ST7.XSN	Holder, Pin	Stainless steel

ST 7-1

ST 7-2

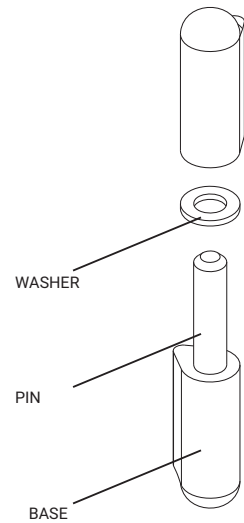
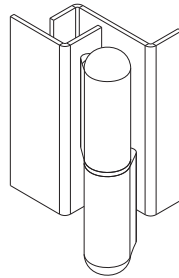
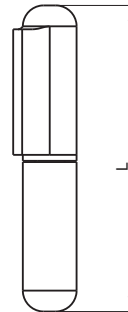
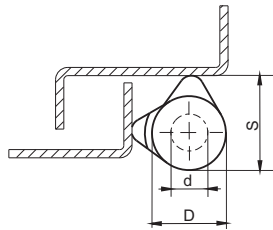

CATALOGUE NUMBER		COMPONENTS		MATERIAL			
3.ST7-1 3.ST7-2		Base, Pin		Steel			
		Washer		Brass			
Cat. No. ST7-1	Cat. No. ST7-2	Dimensions	D	S	d	L	
ST7-1.001A	ST7-2.001A	8x9,5	8	9,5	5	40	
ST7-1.001B	ST7-2.001B	8x9,5	8	9,5	5	50	
ST7-1.002A	ST7-2.002A	10x12	10	12	6	60	
ST7-1.002B	ST7-2.002B	10x12	10	12	6	70	
ST7-1.003	ST7-2.003	13x16	13	16	8	80	
ST7-1.004	ST7-2.004	16x20	16	20	10	100	
ST7-1.005	ST7-2.005	18x22	18	22	12	135	
ST7-1.006	ST7-2.006	20x25	20	25	14	150	
ST7-1.007	ST7-2.007	23x28	23	28,5	16	200	

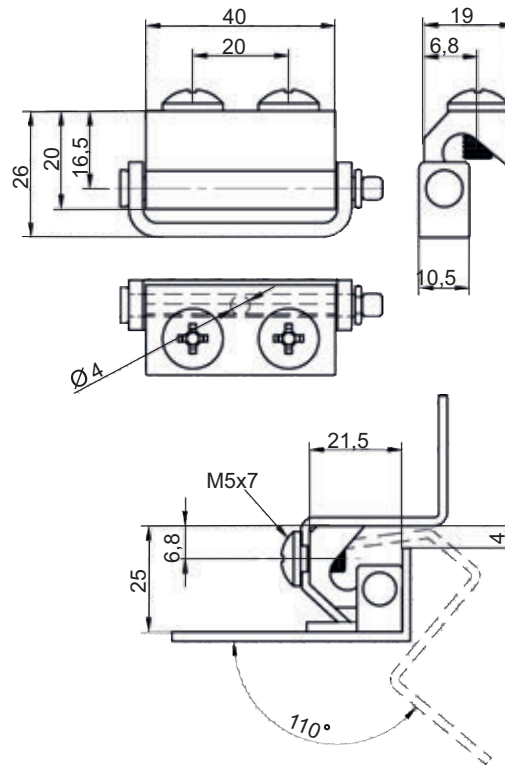

CATALOGUE NUMBER	COMPONENTS	MATERIAL
3.538.001	Holder	Steel copper plated
	Base	Aluminum zinc plated

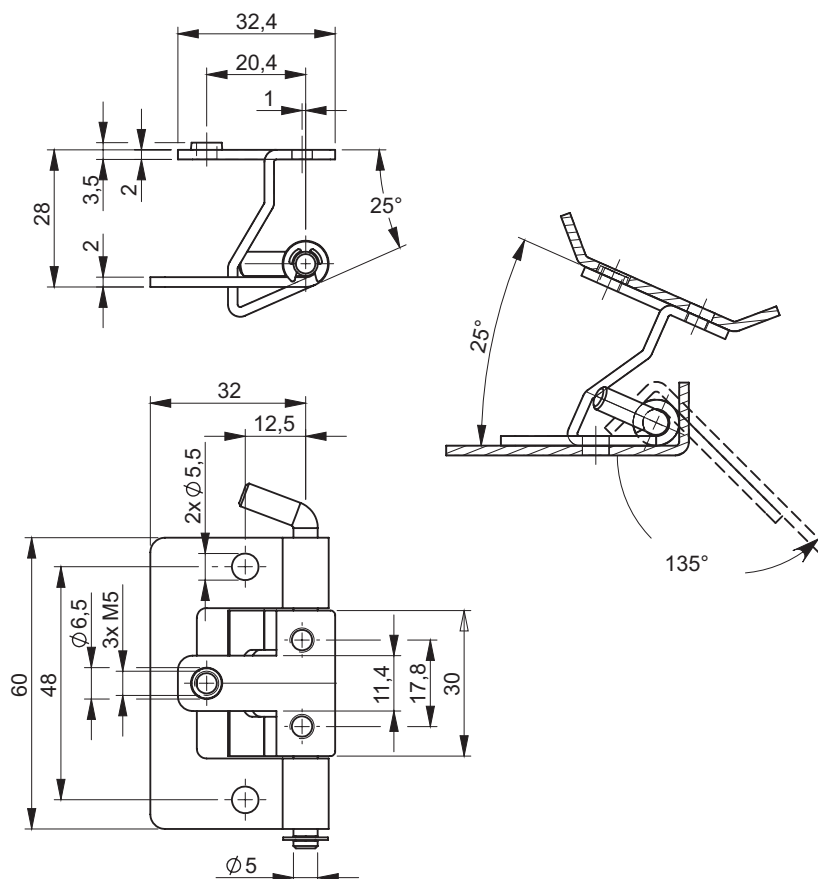

CATALOGUE NUMBER	COMPONENTS	MATERIAL
3.539.001	Holder, Base	Steel zinc plated

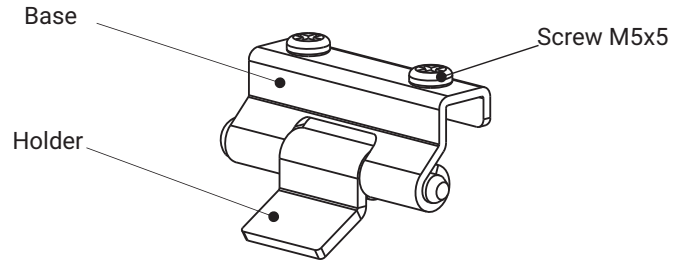
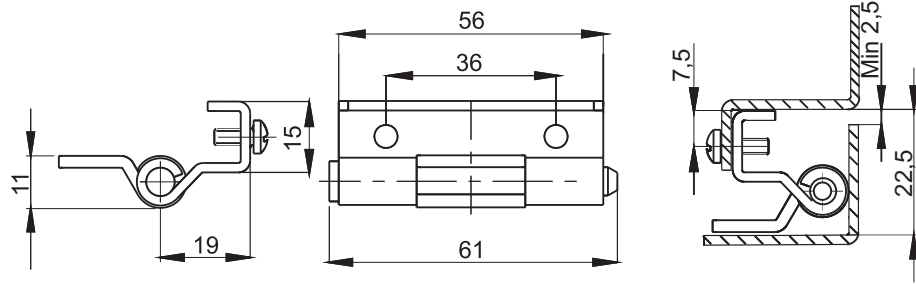

CATALOGUE NUMBER	COMPONENTS	MATERIAL
3.ST551.001	Base	Steel zinc plated
	Holder	Steel copper plated

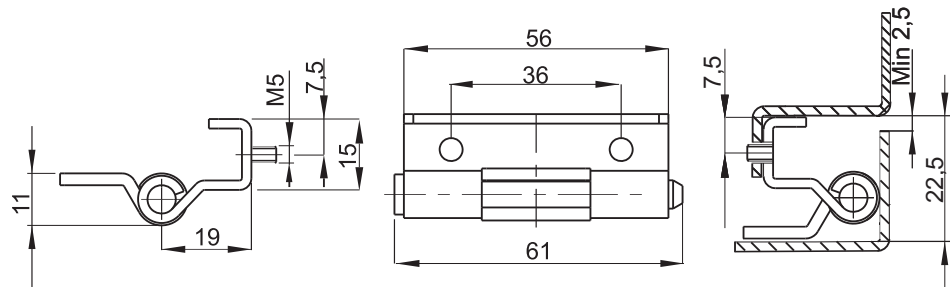
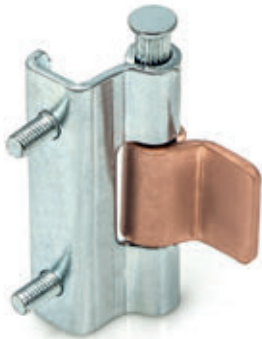

CATALOGUE NUMBER	COMPONENTS	MATERIAL
3.ST552.001	Base	Steel zinc plated
	Holder	Steel copper plated

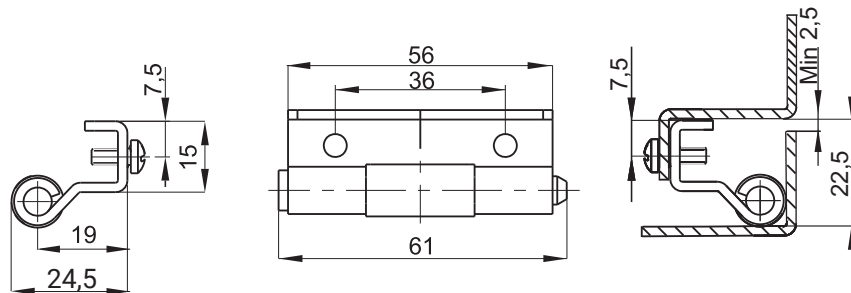

CATALOGUE NUMBER	COMPONENTS	MATERIAL
3.ST553.001	Base	Steel zinc plated
	Holder	Steel copper plated

3.ST558 ver. 001

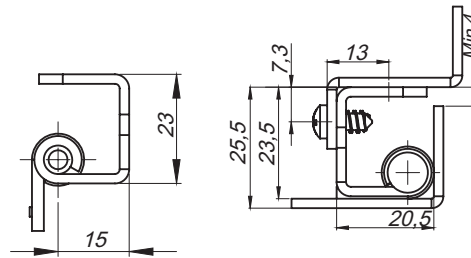

3.ST558 ver. 002

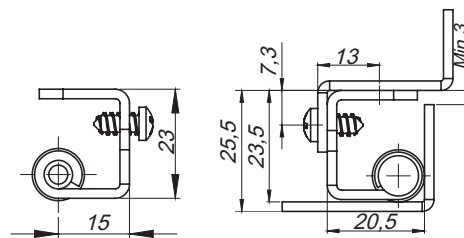
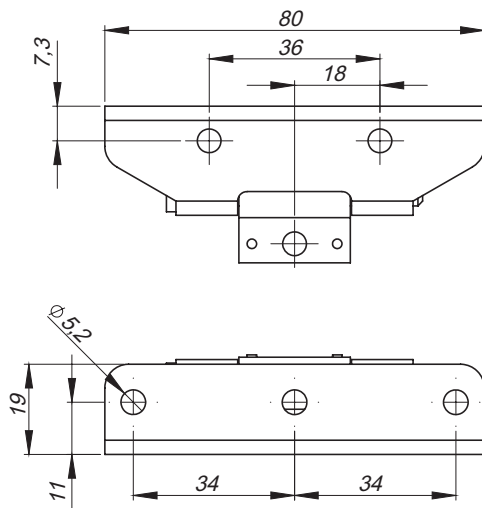

3.ST558 ver. 003

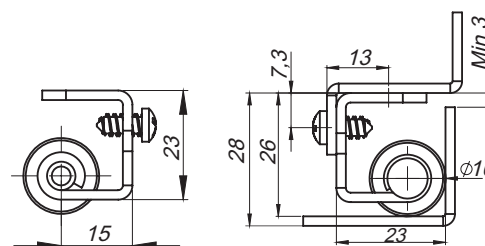

CATALOGUE NUMBER	COMPONENTS	MATERIAL
3.ST558.001	Base, pin	Steel zinc plated
	Holder	Steel copper plated
3.ST558.002	Base, pin	Steel zinc plated
	Collet	Steel copper plated
3.ST558.003	Base, pin	Steel zinc plated
	Collet	Steel copper plated

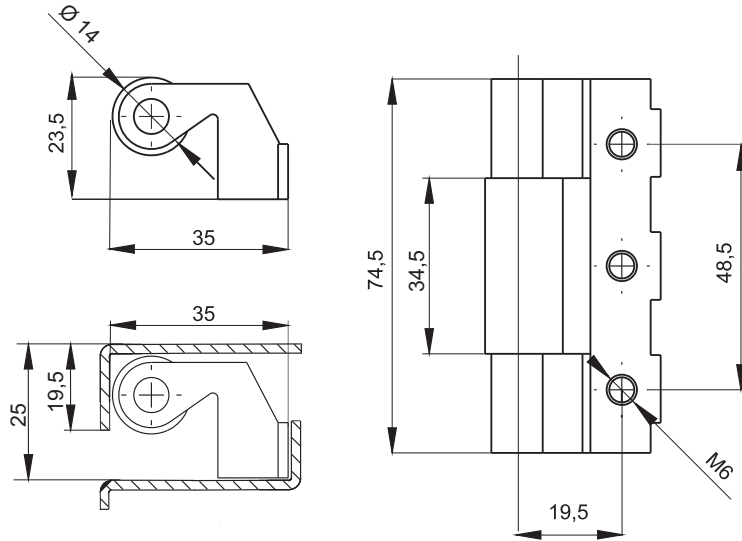

CATALOGUE NUMBER	COMPONENTS	MATERIAL
3.501.001	Base	ZAMAK 5 zinc plated
	Holder	Steel copper plated
	Pin	Steel zinc plated

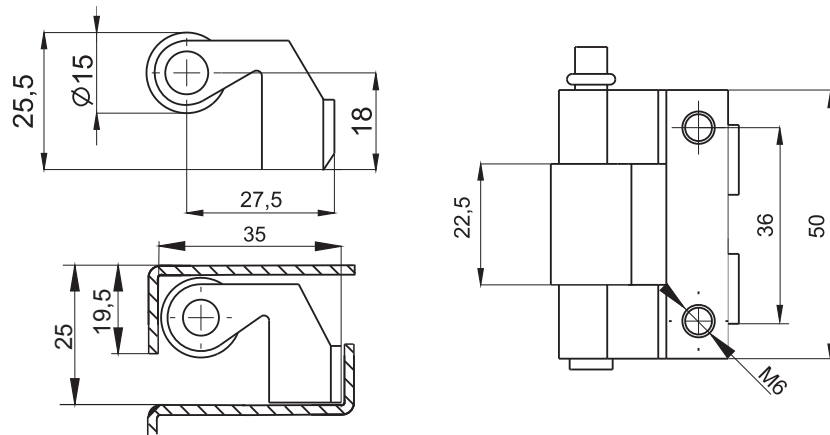

CATALOGUE NUMBER	COMPONENTS	MATERIAL
3.502.001	Base	ZAMAK 5 zinc plated
	Holder	Steel copper plated
	Pin	Steel zinc plated

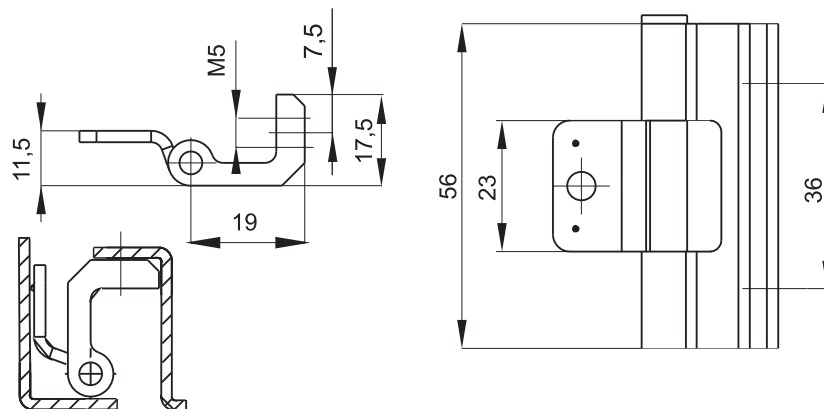

CATALOGUE NUMBER	COMPONENTS	MATERIAL
3.503.001	Base	ZAMAK 5 zinc plated
	Holder	Steel copper plated
	Pin	Steel zinc plated

Left hinge
3.ST300.002SN

Right hinge
3.ST300.001SN

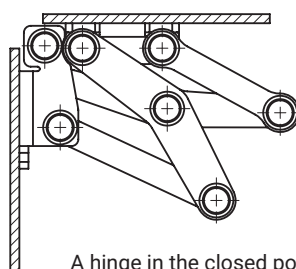
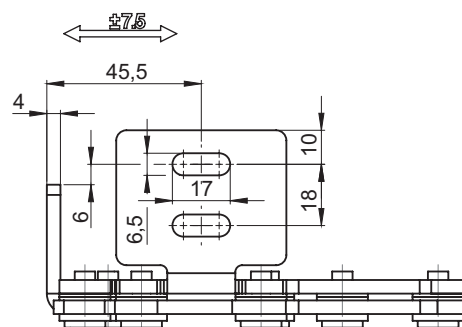
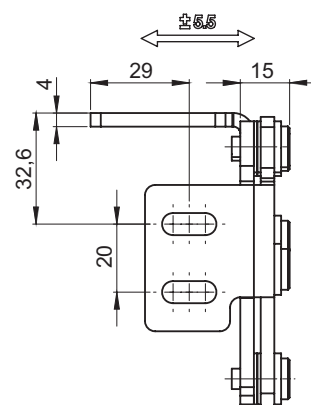
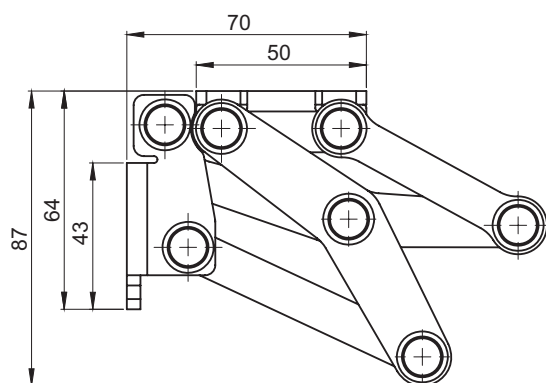
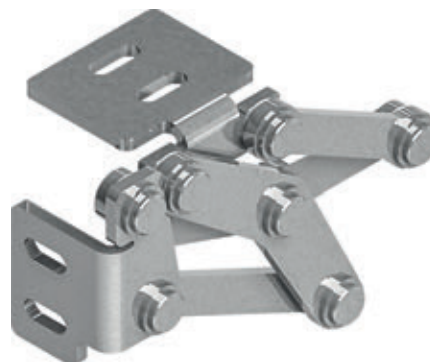

A hinge in the closed position

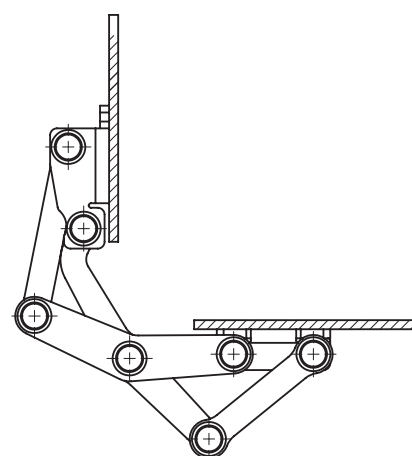

A hinge in the open position

CATALOGUE NO.	VERSION	MATERIAL
3.ST300.001SN	Right	Stainless steel
3.ST300.002SN	Left	



3.ST301.001SN
Right hinge

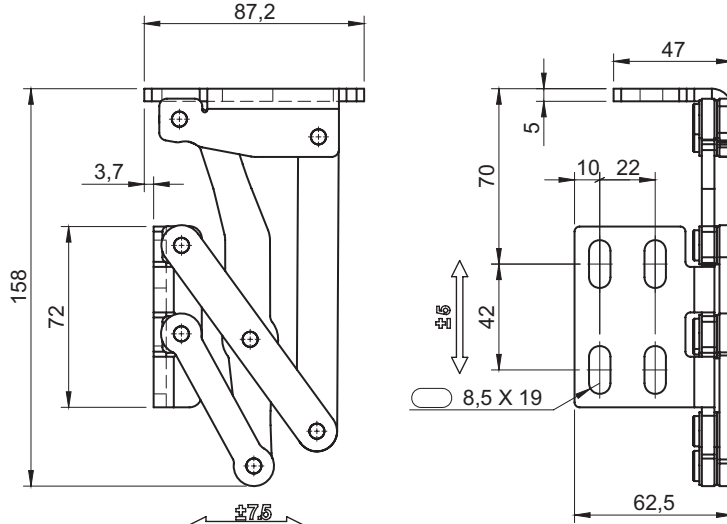

3.ST301.002SN
Left hinge

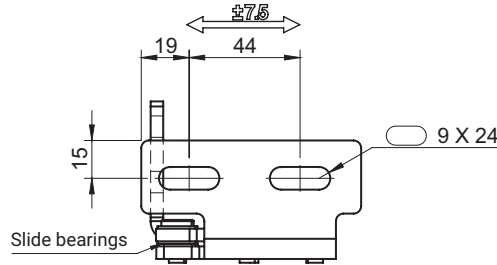

Closed position

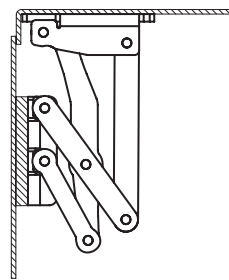

Open position

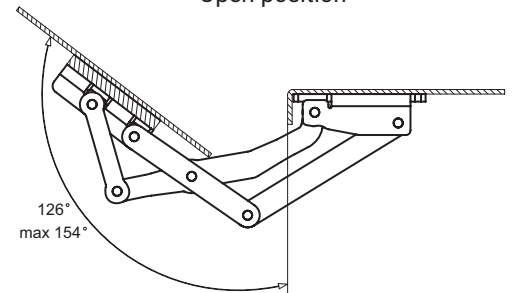

All hinge pivot axes are supported by slide bearings

CATALOGUE NUMBER	VERSION	MATERIAL
3.ST301.001SN	Right	Stainless steel
3.ST301.002SN	Left	

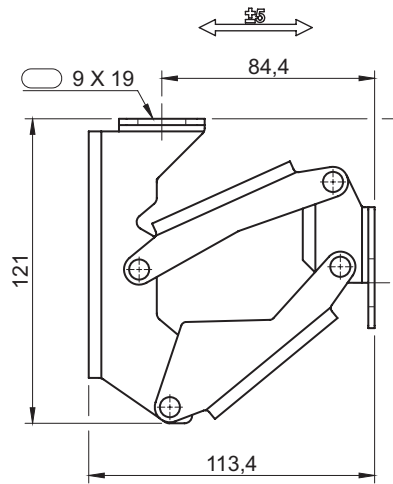
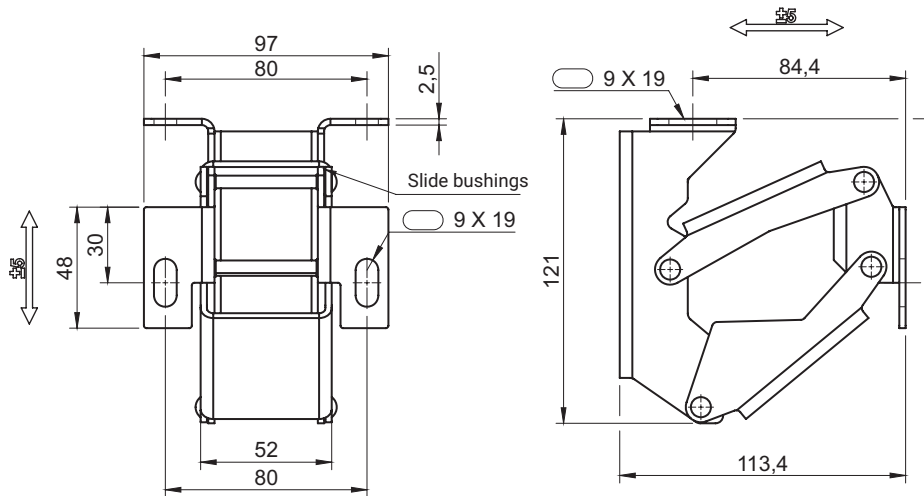
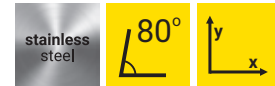

Closed position

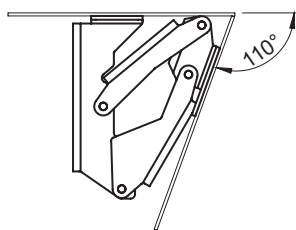

Open position

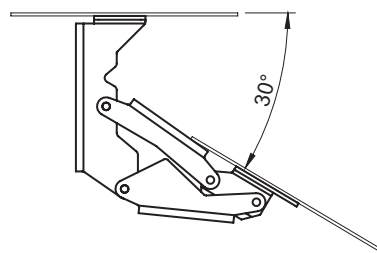

All hinge pivot axes are supported by slide bearings

CATALOGUE NUMBER	MATERIAL
3.ST302.001SN	Stainless steel



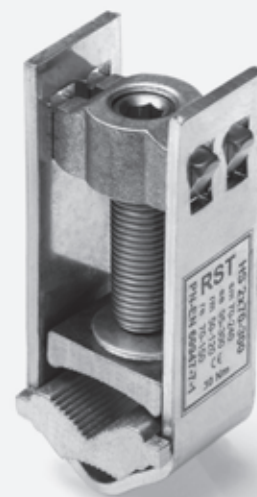

1

Locking systems

2

Locks
Latches

3

Hinges

4

Clamps

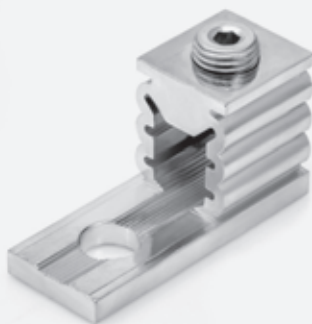

5

Accessories



6

Gasketing profiles

7

Custom products



25-120SW

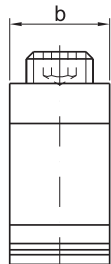
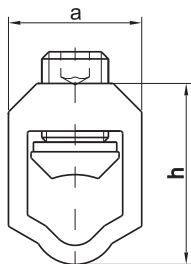

35-240SW
50-240SW

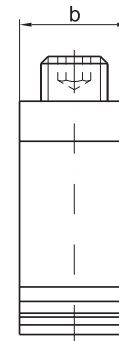
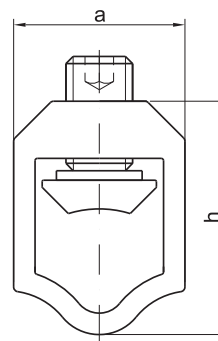

35-240SW-C
50-240SW-C

70-300SW
95-300SW

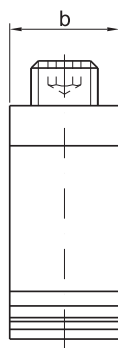
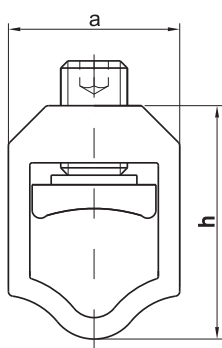

25-120SW-B
50-300SW-B
95-300SW-B

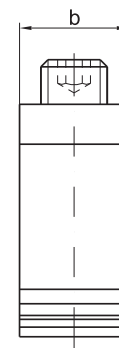
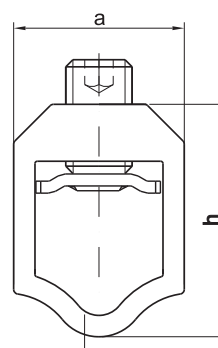

sm - multiwire sector shaped conductor (flexible)



rm - round multiwire conductor (flexible)



se - sector shaped conductor (rigid)



re - round conductor (rigid)

DETAIL	CROSS-SECTION [mm ²]				NOMINAL CROSS-SECTION [mm ²]	MAX TIGHTENING TORQUE [Nm]	DIMENSIONS		
	sm	se	rm	re			a	b	h
25-120SW	25-120	25-120	16-95	16-95	95	20	28	18,5	38
35-240SW	35-185	35-240	25-150	25-95	120	30	35	23	49
50-240SW	50-185	50-240	35-95	35-120	120	30	35	23	49
70-300SW	70-240	95-300	50-120	70-150	150	30	35	23	49
95-300SW	70-240	95-300	50-185	70-240	150	30	37,5	23	54
25-120SW-B	25-120	25-120	16-95	16-120	95	20	28	18,5	38
50-300SW-B*	50-240	50-300	35-240	35-240	150	35	35	23	49
95-300SW-B	50-300	50-300	50-300	50-150	150	30	37,5	23	54
35-240SW-C	35-240	35-240	35-95	35-120	150	30	35	23,2	49
50-240SW-C	50-240	50-240	35-95	35-120	150	30	35	23,2	49

	25-120SW	35-240SW	50-240SW	70-240SW	95-300SW	25-120SW-B	50-300SW-B	95-300SW-B	35-240SW-C	50-240SW-C
clamp	brass- zinc plated					spring steel zinc-plated			nickel-plated zinc-alloy	
housing	aluminium (AlMgSi)									
screw	steel zinc-plated									

SW - hexagon head socked

Screw clamps have safety sign 'B' Wg PN-EN 60947-7-1, (IEC 60947-7-1), EN 61238, EN 60999

* EN 60947-7-1, EN 60947-7-2

Screw clamps v-klema type

Double aluminium



ROZTOCZE

4

2/25-120SW
2/50-240SW
2/25-120SW-D
2/50-240SW-D

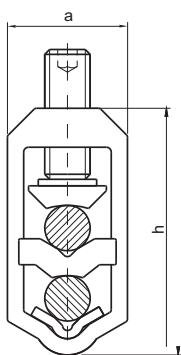

2/70-300SW
2/70-300SW-E

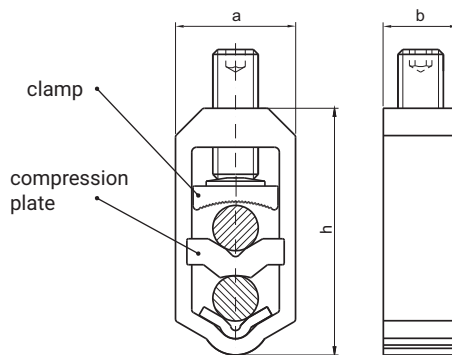

2/25-120SW-B
2/35-300SW-B

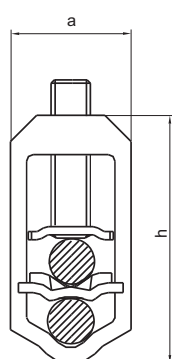

2/25-120SW-E

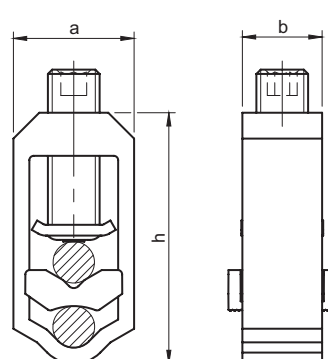

- sm** - multiwire sector shaped conductor (flexible)
- rm** - round multiwire conductor (flexible)
- se** - sector shaped conductor (rigid)
- re** - round conductor (rigid)

DETAIL	CROSS-SECTION [mm ²]				NOMINAL CROSS-SECTION [mm ²]	MAX TIGHTENING TORQUE[Nm]	DIMENSIONS		
	sm	se	rm	re			a	b	h
2/25-120SW	25-120	25-120	16-95	16-95	95	20	28	18	58
2/50-240SW	35-185	35-240	35-120	35-150	150	30	37	23	76
2/70-300SW	70-240	95-300	50-120	70-150	150	30	37	23	76
2/25-120SW-B	25-120	25-120	16-120	16-120	95	20	28	18	58
2/35-300SW-B	50-240	50-240	35-300	50-150	150	30	37	23	76
2/25-120SW-D	25-120	25-120	16-95	16-95	95	20	28	18	58
2/50-240SW-D	35-185	35-240	35-120	35-150	150	30	37	23	76
2/70-300SW-E	70-240	95-300	50-120	70-150	150	30	37	23	76
2/25-120SW-E	25-120	25-120	16-95	16-95	95	20	28	18	58

	2/25-120SW	2/50-240SW	2/70-300SW	2/25-120SW-B	2/35-300SW-B
clamp	brass- zinc plated			spring steel zinc-plated	
compression plate	brass- zinc plated			spring steel zinc-plated	
housing	aluminium (AlMgSi)				
screw	steel zinc-plated				
	2/25-120SW-D	2/50-240SW-D	2/70-300SW-E	2/25-120SW-E	
clamp	brass- zinc plated	ZAMAK tin-plated	brass- zinc plated	spring steel zinc-plated	
compression plate	ZAMAK tin-plated				
housing	aluminium (AlMgSi)				
screw	steel zinc-plated				

* SW - hexagon head socked
* Screw clamps have safety sign 'B' Wg PN-EN 60947-7-1, (IEC 60947-7-1), EN 61238, EN 60999

16-120 SW

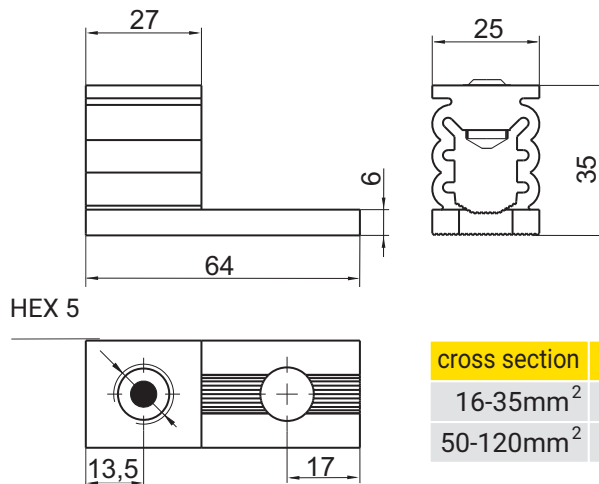

cross section	tightening torque
16-35mm ²	12 Nm
50-120mm ²	25 Nm

For the multiwire sector shaped conductor **rm** the need to use the tip of the sleeve DIN 46228/4



10-150.SW.A

10-150.SW.B

10-150.SW.C1

10-150.SW.C2

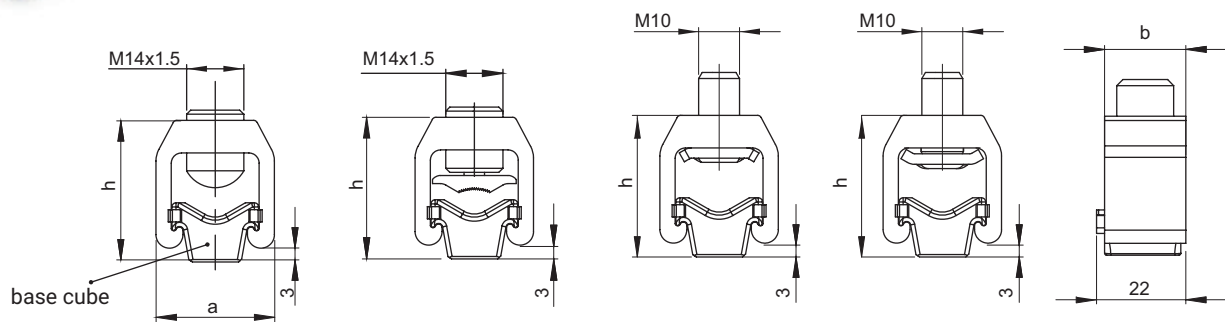

- sm** - multiwire sector shaped conductor (flexible) **rm** - round multiwire conductor (flexible)
- se** - sector shaped conductor (rigid) **re** - round conductor (rigid)

DETAIL	CROSS-SECTION [mm ²]				NOMINAL CROSS-SECTION [mm ²]	MAX TIGHTENING TORQUE [Nm]	DIMENSIONS		
	sm	se	rm	re			a	b	h
16-120SW	-	-	16-120	16-120	120	12-25	25	27	35
10-150.SW.A	35-120	35-150	10-95	10-120	120	15	29	20	34
10-150.SW.B	35-70	35-95	10-50	10-70	95	15	29	20	34
10-150.SW.C	35-70	35-95	10-50	10-70	95	15	29	20	34

	16-120SW	10-150.SW.A	10-150.SW.B	10-150.SW.C1/C2
clamp	-	-	brass tin-plated	spring steel zinc-plated
base cube	-	Brass tin-plated		
housing	aluminium (AlMgSi)			
screw	brass tin-plated			steel zinc-plated

* SW - hexagon head socked.

* Screw clamps have safety sign 'B' WG PN-EN 60947-7-1, (IEC 60947-7-1)

HM 6-50

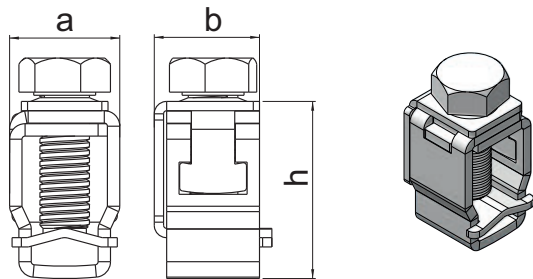

HS 10-95

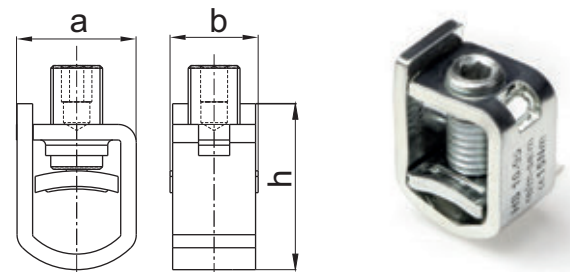

HS 6-50

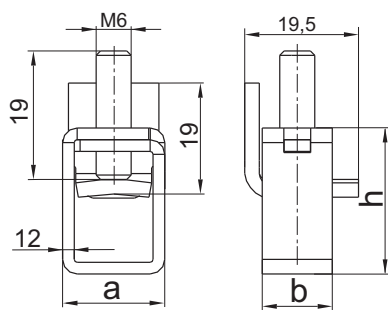

HM 10-95/A HM 25-150/A HM 10-95/C HM 25-150/B

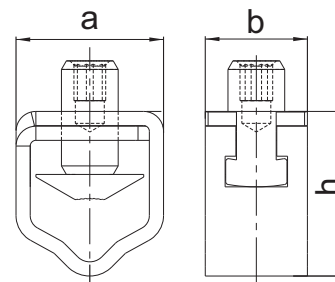

HM 10-95/B

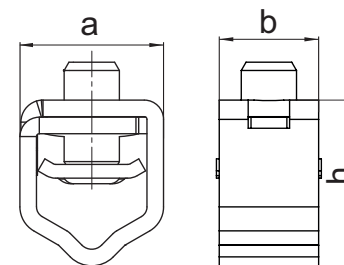

- sm** - multiwire sector shaped conductor (flexible) **rm** - round multiwire conductor (flexible)
- se** - sector shaped conductor (rigid) **re** - round conductor (rigid)

DETAIL	CROSS-SECTION [mm ²]				NOMINAL CROSS-SECTION [mm ²]	MAX TIGHTENING TORQUE [Nm]	DIMENSIONS		
	sm	se	rm	re			a	b	h
HM 6-50	25-50	25-50	6-50	6-50	50	8	18	16	30
HM 10-95/A	25-95	20-120	10-70	10-70	95	15	26	18	30
HM 10-95/B	25-95	20-120	10-70	10-70	95	15	26	18	30
HM 10-95/C	25-95	20-120	10-70	10-70	95	15	26	18	30
HM 25-150/A	25-120	35-150	25-120	35-120	95	25	26	18	31,5
HM 25-150/B	25-120	35-150	25-120	35-120	95	25	26	18	31,5
HS 6-50	-	-	6-50	6-50	50	6	17,5	12	25
HS 10-95	25-95	25-95	10-95	10-70	95	15	23	16	32

	HM 6-50	HS 6-50	HS 10-95	HM 10-95/A	HM 10-95/B	HM 10-95/C	HM 25-150/A	HM 25-150/B
housing	spring steel zinc-plated		stainless steel	spring steel zinc-plated	spring steel zinc-plated	spring steel zinc-plated	stainless steel	steel zinc-plated
clamp	spring steel zinc-plated		Brass tin-plated	spring steel zinc-plated	Brass tin-plated	Brass tin-plated	Brass tin-plated	Brass tin-plated
screw	steel zinc-plated		stainless steel	steel zinc-plated	steel zinc-plated	steel zinc-plated	stainless steel	steel zinc-plated

* Screw clamps have safety sign 'B' WG PN-EN 60947-7-1, (IEC 60947-7-1)

HS25-240

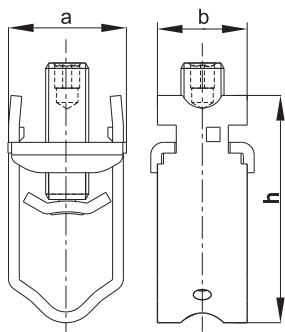

**HS 35-300-B
HS 50-300-B**

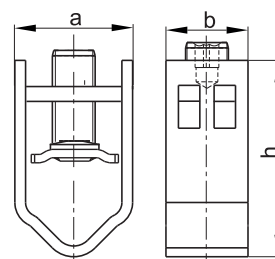

HS 70-300

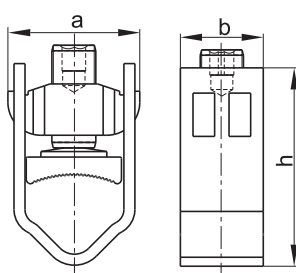

HS 50-240

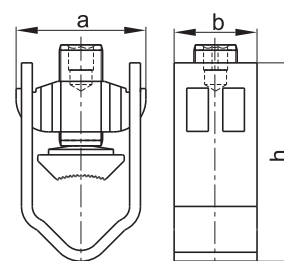

HS 120-300

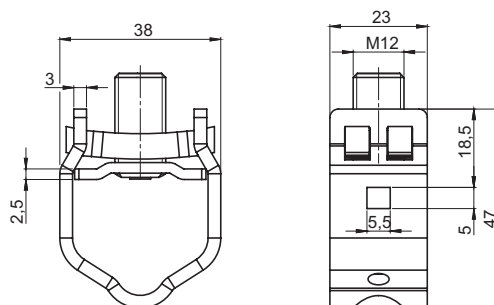

- sm** - multiwire sector shaped conductor (flexible)
- rm** - round multiwire conductor (flexible)
- se** - sector shaped conductor (rigid)
- re** - round conductor (rigid)

DETAIL	CROSS-SECTION [mm ²]				NOMINAL CROSS-SECTION [mm ²]	MAX TIGHTENING TORQUE [Nm]	DIMENSIONS		
	sm	se	rm	re			a	b	h
HS 25-240	50-240	50-240	25-185	25-95	240	30	33	25	63
HS 50-240	50-185	50-240	35-120	35-150	150	40	35	22	55
HS 70-300	70-240	95-300	50-150	70-185	185	40	35	22	55
HS 35-300-B	35-240	50-300	35-300	35-185	185	40	35	22	55
HS 50-300-B	50-240	70-300	50-300	50-185	185	40	35	22	55
HS 120-300	120-300	120-300	120-300	120-300	300	40	38	23	47

	HS 25-240	HS 50-240	HS 70-300	HS 35-300-B	HS 50-300-B	HS 120-300
housing	Spring steel zinc-plated					Stainless steel
clamp	Spring steel zinc-plated	Brass tin-plated		Spring steel zinc-plated		
screw	Steel zinc-plated					
nut	Steel zinc-plated	Brass tin-plated		Steel zinc-plated		

* Screw clamps have safety sign 'B' WG PN-EN 60947-7-1, (IEC 60947-7-1)

Screw clamps v-klema type HS steel double



ROZTOCZE

4

HS 2/50-240

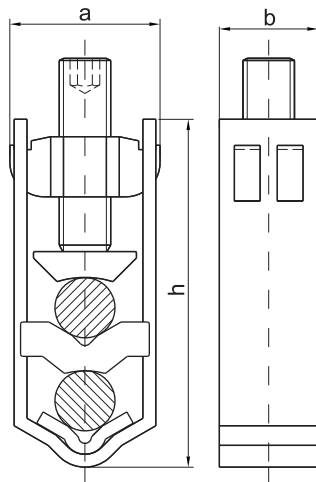

HS 2/50-240-B

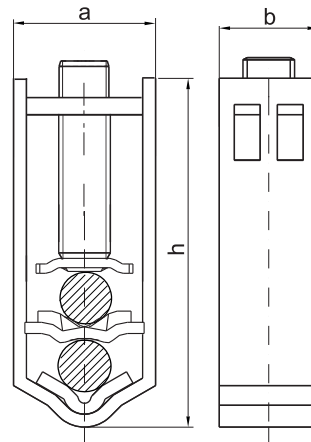

HS 2/50-240-D

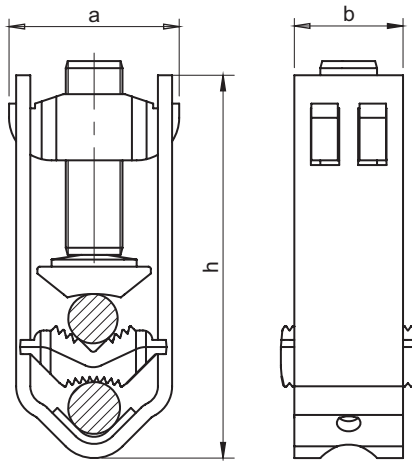

HS 2/50-240-E

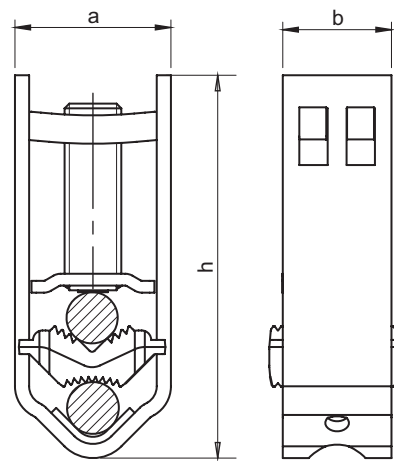

- sm** - multiwire sector shaped conductor (flexible) **rm** - round multiwire conductor (flexible)
- se** - sector shaped conductor (rigid) **re** - round conductor (rigid)

DETAIL	CROSS-SECTION [mm ²]				NOMINAL CROSS-SECTION [mm ²]	MAX TIGHTENING TORQUE [Nm]	DIMENSIONS		
	sm	se	rm	re			a	b	h
HS 2/50-240	50-185	50-240	35-150	35-185	185	40	35	22	81
HS 2/50-240-B	35-240	35-300	35-300	50-185	185	40	35	22	81
HS 2/50-240-D	50-185	50-240	35-150	35-185	185	40	36	23	81
HS 2/50-240-E	35-240	35-300	35-300	50-185	185	40	35	23	81





	HS 2/50-240	HS 2/50-240-B	HS 2/50-240-D	HS 2/50-240-E
clamp	Brass tin-plated	steel zinc-plated	ZAMAK tin-plated	
housing	spring steel zinc-plated			
screw	steel zinc-plated			
compression plate	Brass tin-plated		ZAMAK tin-plated	
nut	Brass tin-plated	spring steel zinc-plated		Brass tin-plated

* Screw clamps have safety sign 'B' WG PN-EN 60947-7-1, (IEC 60947-7-1)

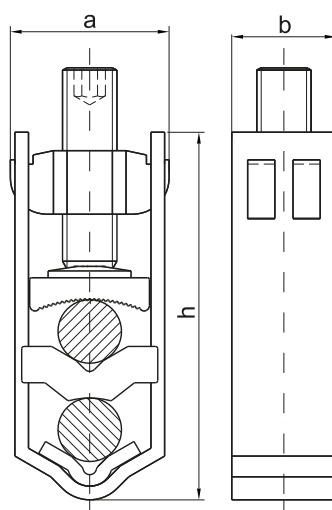

HS 2/70-300



-  **sm** - multiwire sector shaped conductor (flexible)
  **rm** - round multiwire conductor (flexible)
 **se** - sector shaped conductor (rigid)
  **re** - round conductor (rigid)

DETAIL	CROSS-SECTION [mm ²]				NOMINAL CROSS-SECTION [mm ²]	MAX TIGHTENING TORQUE [Nm]	DIMENSIONS		
	sm	se	rm	re			a	b	h
HS 2/70-300	70-240	95-300	50-120	70-150	185	30	35	22	81

	HS 2/70-300
clamp	Brass tin-plated
housing	spring steel zinc-plated
screw	steel zinc-plated
compression plate	Brass tin-plated
nut	Brass tin-plated

* Screw clamps have safety sign 'B' WG PN-EN 60947-7-1, (IEC 60947-7-1)

HM 2/10-70-A

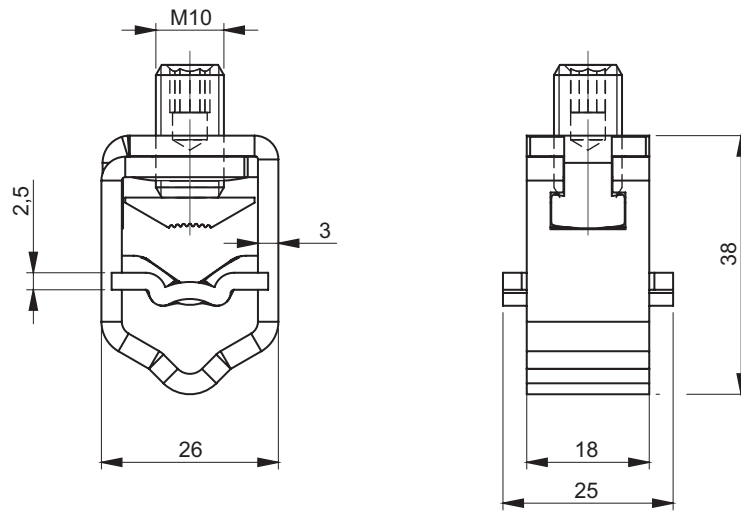

HM 2/10-70-B

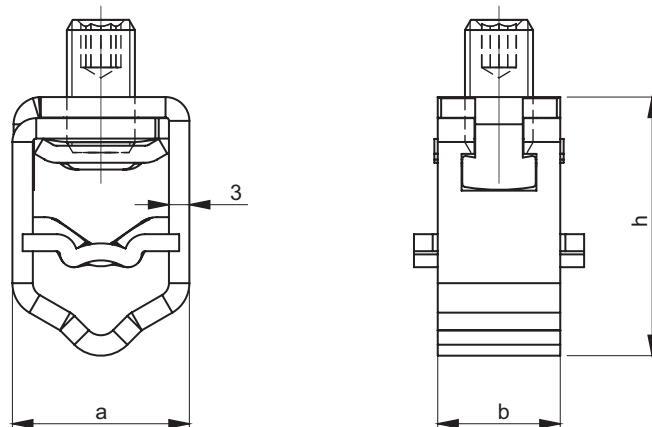

- sm** - multiwire sector shaped conductor (flexible) **rm** - round multiwire conductor (flexible)
- se** - sector shaped conductor (rigid) **re** - round conductor (rigid)

DETAIL	CROSS-SECTION [mm ²]				MAX TIGHTENING TORQUE [Nm]	DIMENSIONS		
	sm	se	rm	re		a	b	h
HM 2/10-70-A	10-50	10-70	10-35	10-50	15	26	18	38
HM 2/10-70-B	10-50	10-70	10-35	10-50	15	26	18	38

	HM 2/10-70-A	HM 2/10-70-B
Clamp	Brass tin-plated	Steel zinc-plated
Housing	Steel zinc-plated	Steel zinc-plated
Screw	Steel zinc-plated	Steel zinc-plated
Compression plate	Copper tinned	Copper tinned

* Screw clamps have safety sign 'B' WG PN-EN 60947-7-1, (IEC 60947-7-1)



Connecting device RBK LZ6V

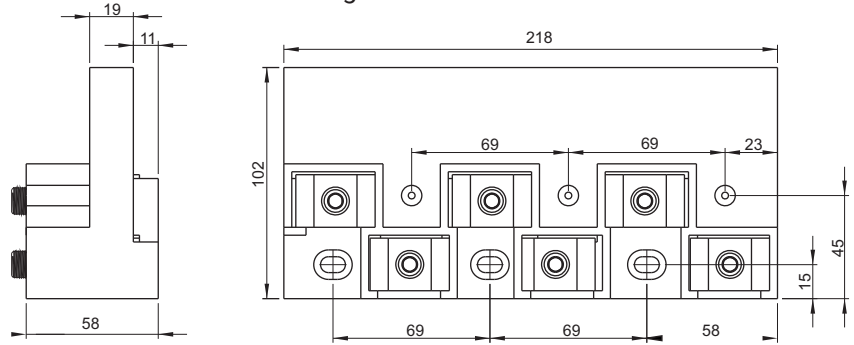

Terminals for connecting device 4.601.001



4.601.101, 4.601.201

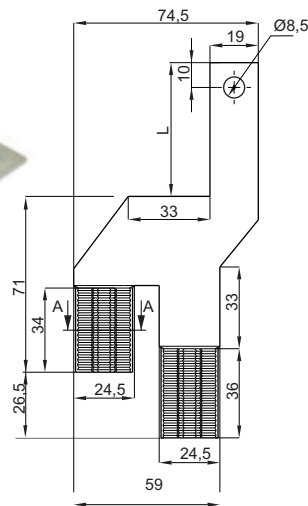

4.601.102

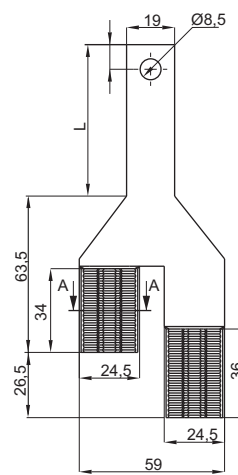

4.601.103, 4.601.203

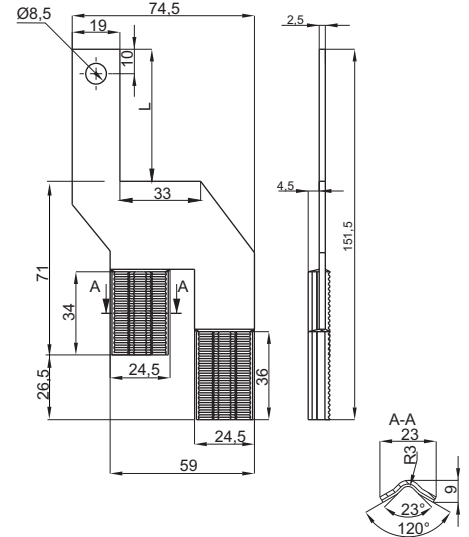

4.601.401

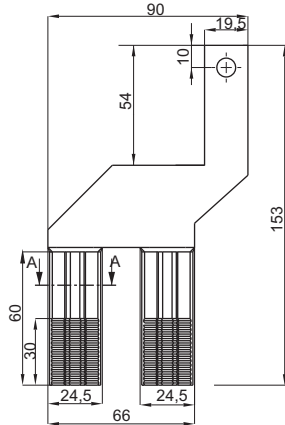

4.601.402

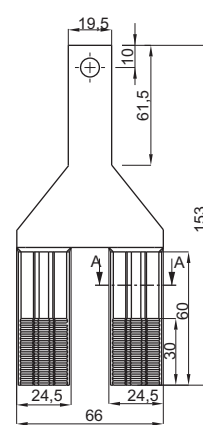

4.601.403

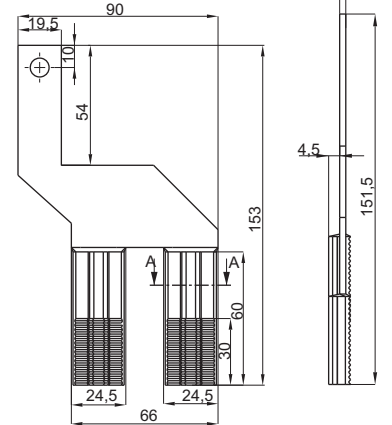

CATALOGUE NUMBER	NAME	MATERIAL	L [mm]
4.601.001	Connecting device LZ6V	Polyamide PA6 - colour white	-
4.601.101	Terminals	Tin-plated copper	54
4.601.201			42
4.601.102			63,5
4.601.202			50
4.601.103			54
4.601.203			42
4.601.401			-
4.601.402			-
4.601.403			-

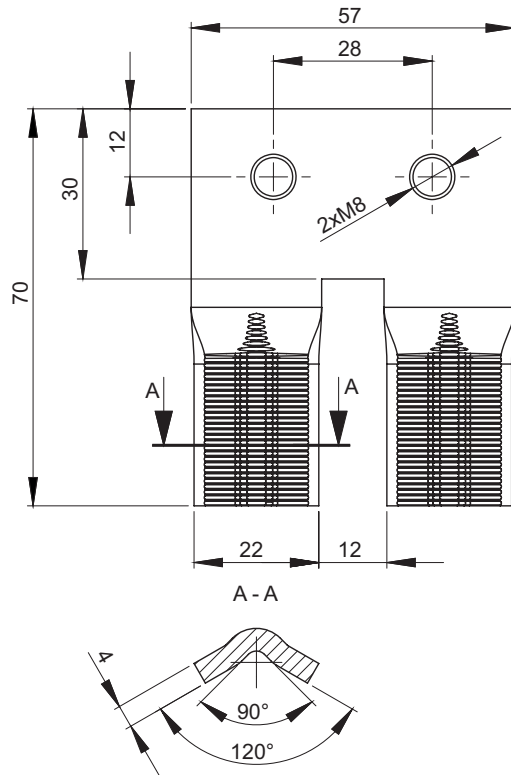

CATALOGUE NO.	DETAIL	MATERIAL
4.603.003	Terminal	Tin-plated copper

Terminal is dedicated to clamps pg.: 4-1 (in main catalogue) except 25-120 SW, 25-120 SW-B; 4-2 except 2,25-120 SW, 2/25-120 SW-B; 4-5; 4-6 (in main catalogue) except HS 2/70-240-C.

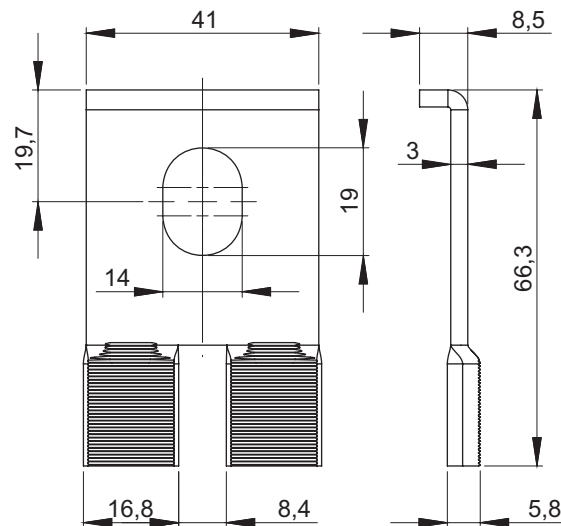

CATALOGUE NO.	DETAIL	MATERIAL
4.603.004	Terminal	Steel zinc plated

Terminal is dedicated to clamps HS 10-95 (pg. 4-4 in main catalogue)

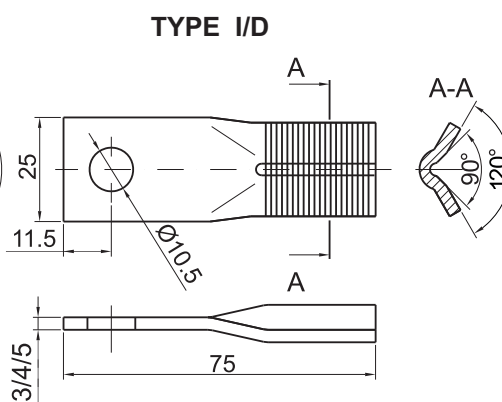
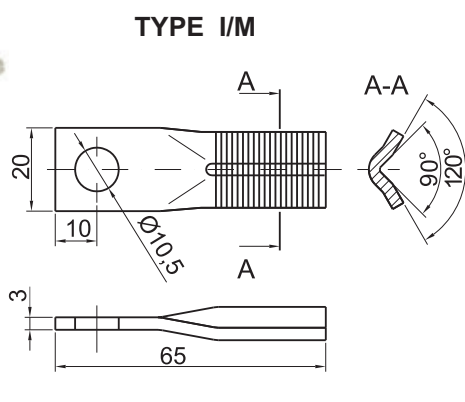
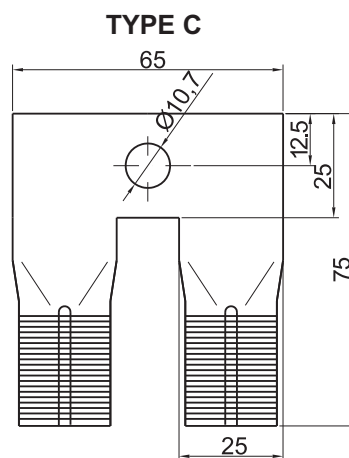
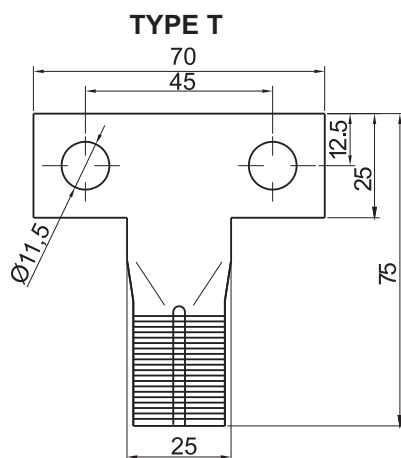

4-SCREW CLAMP

GROUND CLAMP

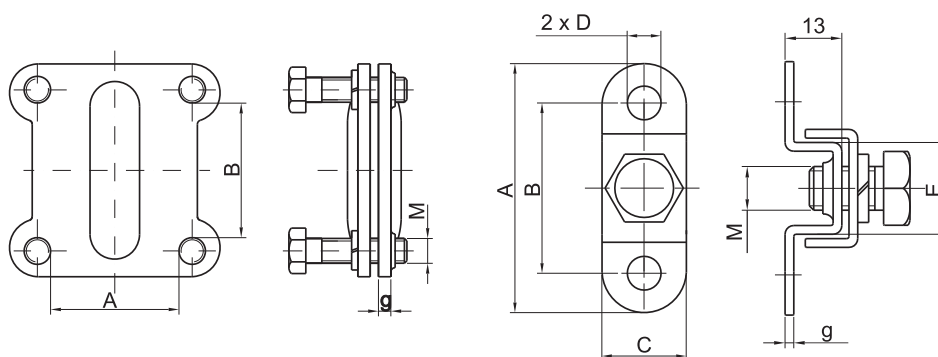

CAT. NUMBER	NAME	MATERIAL	A	B	C	D	E	g	M
4.406.001	Ground clamp	Steel zinc plated	53	39	18	ø 6,5	19	2	M8x16
4.406.002			62	42	21	ø 8,5	22	2,5	M10x16
4.405.001	4-Screw clamp	Steel zinc plated	20	25	-	-	-	3	M6
4.405.002			25	30	-	-	-	3	M6
4.405.003			30	30	-	-	-	3	M6
4.405.004			35	40	-	-	-	5	M8
4.405.005			40	40	-	-	-	5	M8
T, C, I/m, I/D	Terminals type T, C, I/m, I/D Cooper - tin plated								

V-KLEMY COVERS

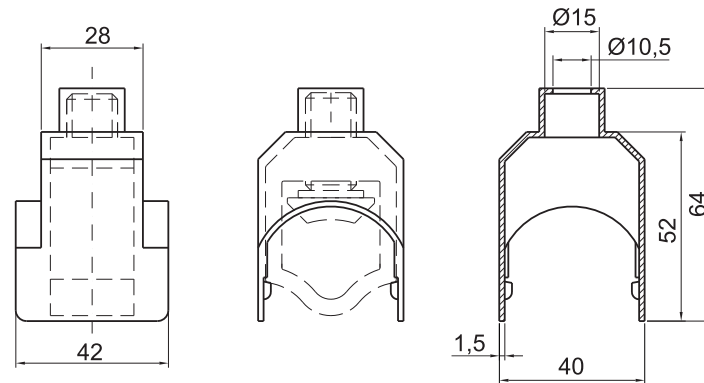

CTALOGUE NUMBER	NAME	MATERIAL	COLORS [x]												
4.520.001.0X	V-klema cover	PA6-polyamide	<table border="1"> <tr><td>01</td><td>black</td></tr> <tr><td>02</td><td>blue</td></tr> <tr><td>03</td><td>red</td></tr> <tr><td>04</td><td>green</td></tr> <tr><td>05</td><td>yellow</td></tr> <tr><td>06</td><td>grey</td></tr> </table>	01	black	02	blue	03	red	04	green	05	yellow	06	grey
01	black														
02	blue														
03	red														
04	green														
05	yellow														
06	grey														

NOTICE:
V-klema covers can be used with screw clamps type:
50-240SW, 70-300SW, 50-300SW i 35-240SW

LINEAR CLAMP - ZLG 4.402.001

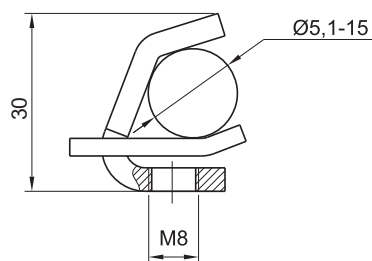
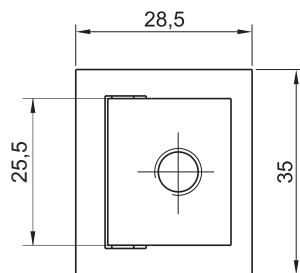

GOUND HOLDER 4.403.001

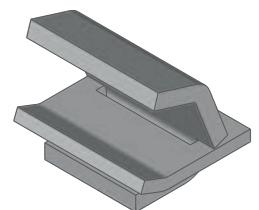
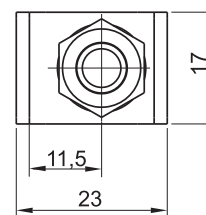
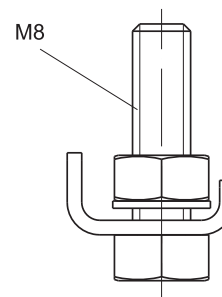

CTALOGUE NUMBER	NAME	MATERIAL
4.402.001	Linear clamp ZLG	Stainless steel
4.403.001	Ground clamp ZU	Stainless steel or steel zinc plated

ROUND NUT

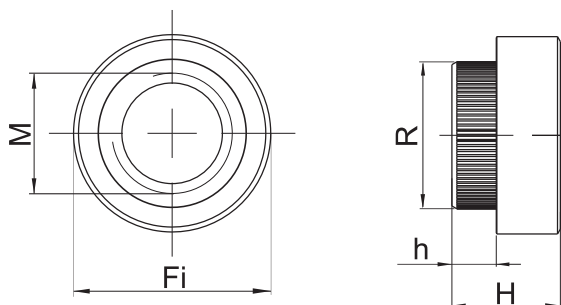

HEXAGONAL NUT

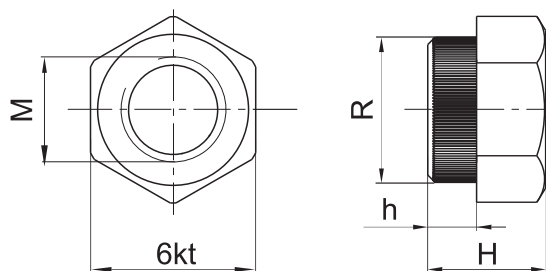

SHAPE	DIMENSIONS						MATERIAL	CAT. NUMBER
	M	Fi	6kt	Fi R	H	h		
	12	20		14,9	11	4,5	Steel - zinc plated	NR.01.00
	12	20		14,9	10,5	4	Steel - zinc plated	NR.01.02
	12	19		15	11	4	Steel - zinc plated	NR.01.03
	10	18		13	11	4,5	Steel - zinc plated	NR.03.01
	8	15		10,8	9,5	4,5	Steel - zinc plated	NR.02.01
	6	12		8,5	6,8	2,8	Steel - zinc plated	NR.04.01
	5	10		7,5	6,8	2,8	Steel - zinc plated	NR.05.01
	12		19	14,8	12	4,5	Steel - zinc plated	NR.01.04
	10		17	12,9	11	4,5	Steel - zinc plated	NR.03.02
	8		13	10,7	9,5	4,5	Steel - zinc plated	NR.02.02

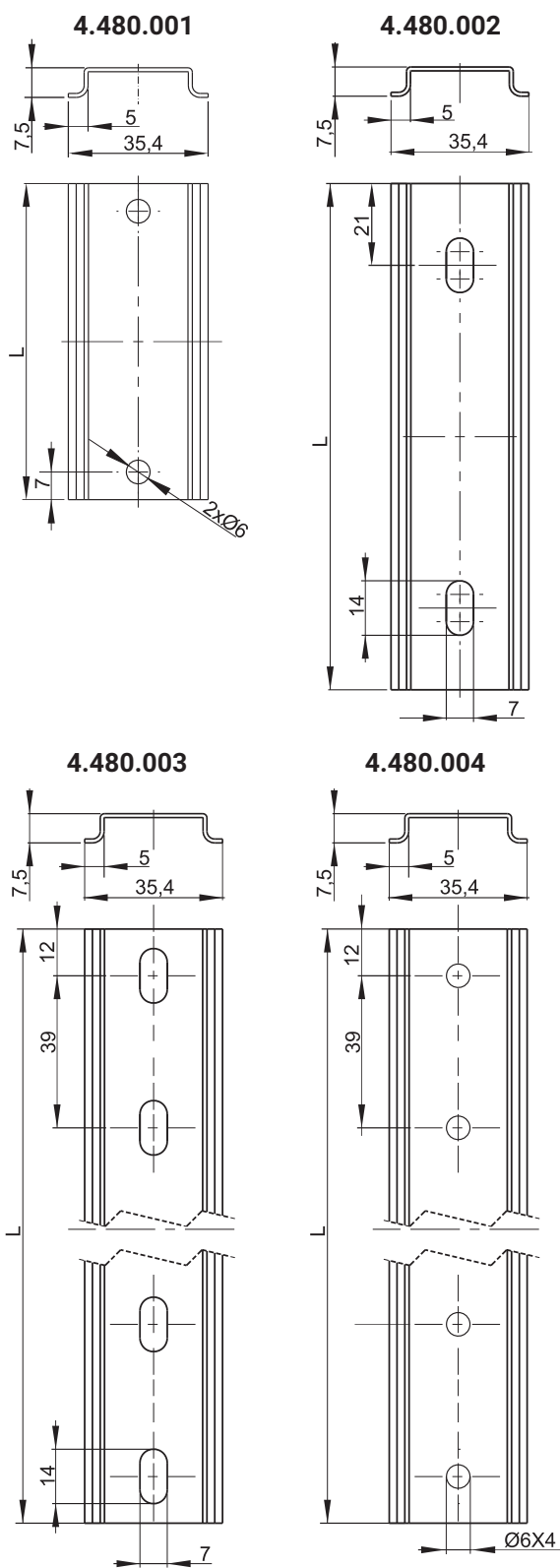

CAT. NUMBER	DIMENSION L	MATERIAL
4.480.001	80	Steel - zinc plated
4.480.002.L	130	Steel - zinc plated
4.480.002.L	140	Steel - zinc plated
4.480.002.L	260	Steel - zinc plated
4.480.003	360	Steel - zinc plated
4.480.004	360	Steel - zinc plated

NOTICE: Other dimensions on request



4.460.001

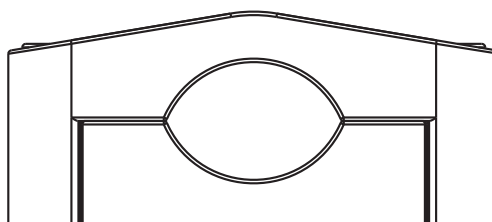

4.461.001

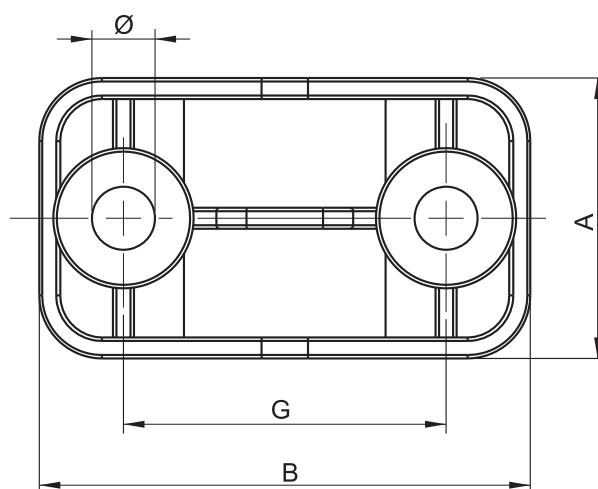

4.462.001

CAT. NUMBER	NAME	MATERIAL	DIAMETER	DIMENSIONS			
				Φ	A	B	G
4.460.001	Clasp ø27	Polyamide PA6 colour RAL	17-27	9	40	70	46
4.461.001	Clasp ø40		25-46	12	58	97	68
4.462.001	Clasp ø75		47-73	13	60	126,5	95



1

Locking systems

2

Locks
Latches

3

Hinges

4

Clamps

5

Accessories

6

Gasketing profiles

7

Custom products

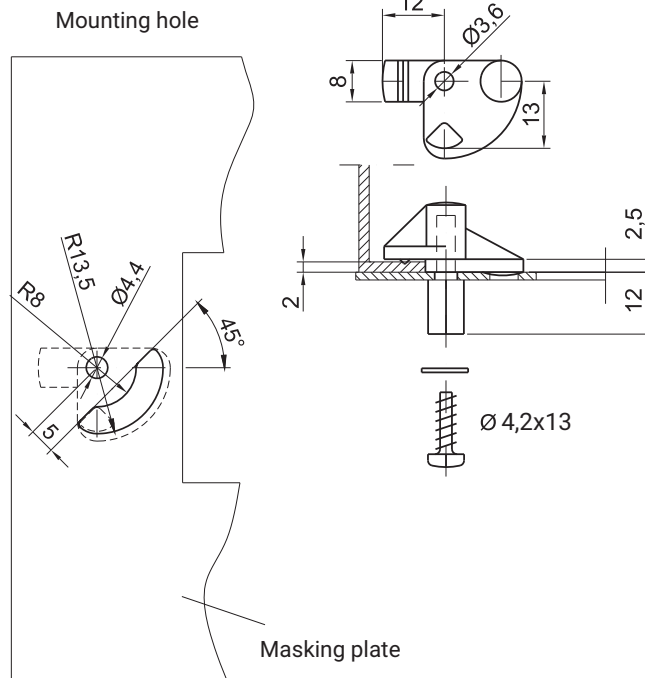

CAT. NUMBER	NAME	MATERIAL
4.415.001	Masking plate holder	Polyamide

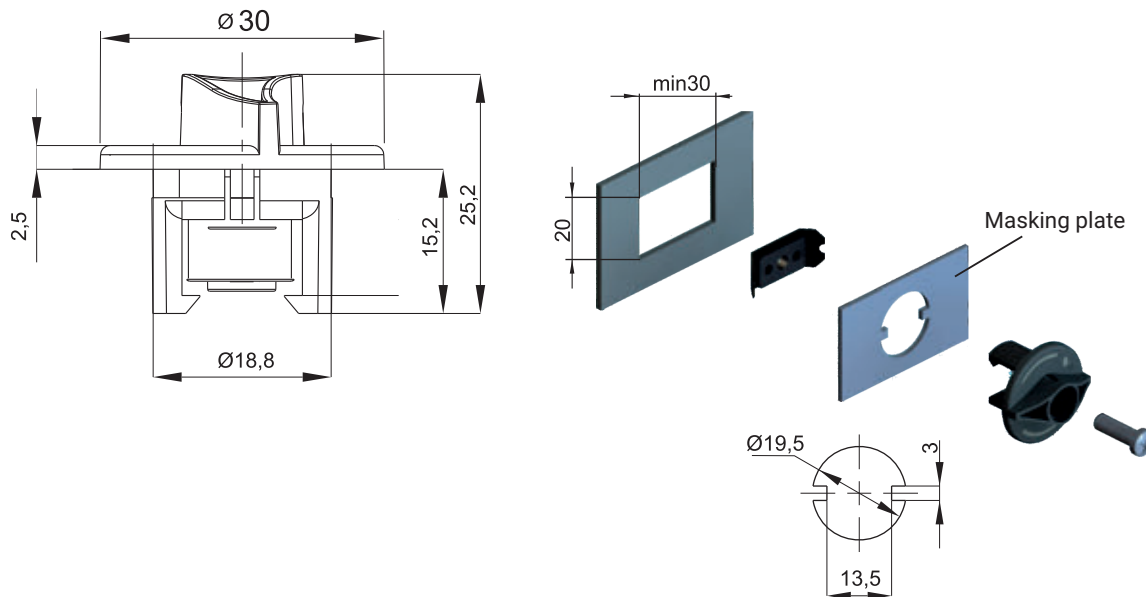

CAT. NUMBER	NAME	MATERIAL
4.414.001	Masking plate holder	Polyamide

* possibility order parts according to RAL

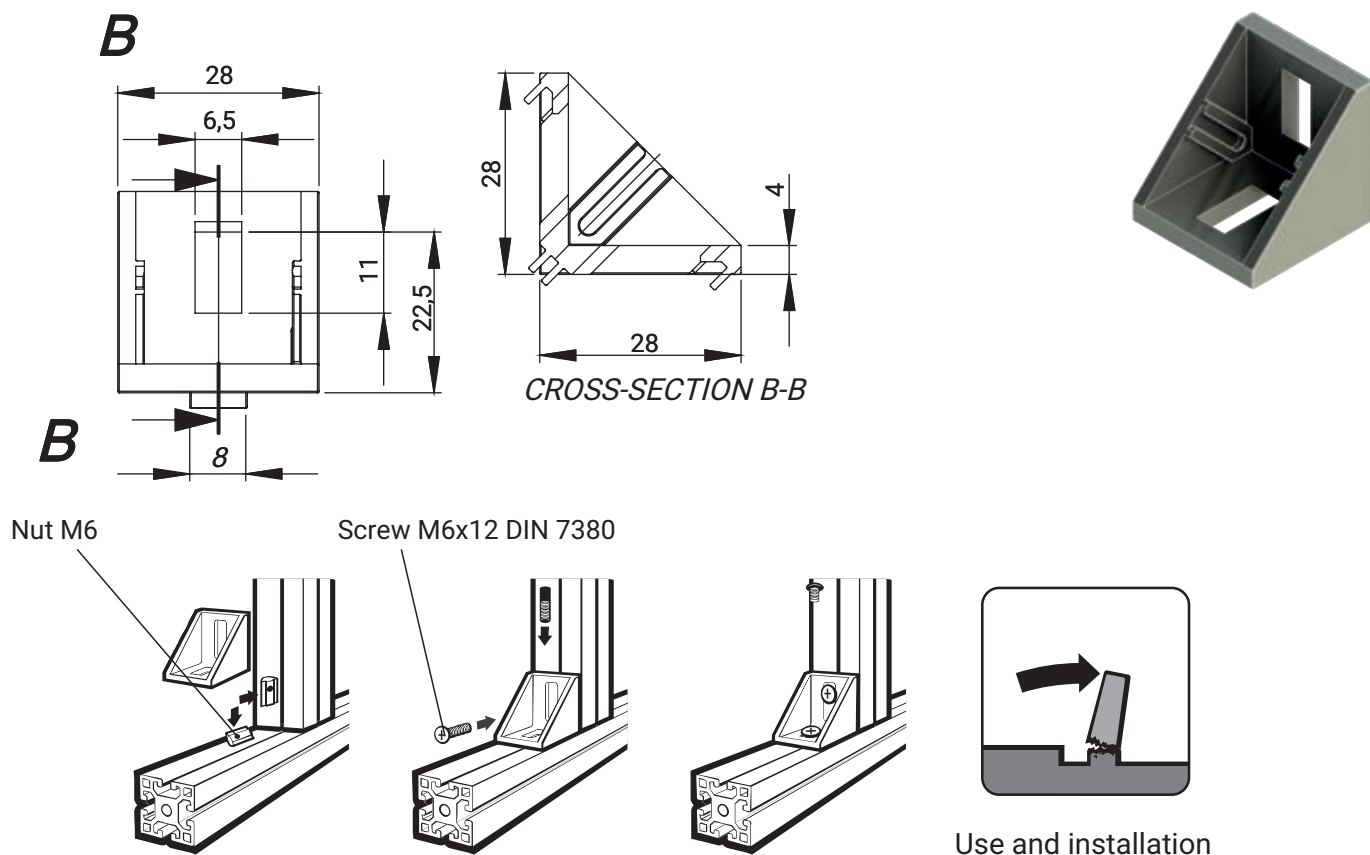

CAT. NUMBER	XY	FINISH	COMPONENTS	MATERIAL
4.500.001.XY	01	No	Connector	Zamak 5
	11	RAL 7035*		
4.500.001.02		-	Nut M6	Zamak 5
4.500.001.03		-	Screw M6x12 DIN 7380	Steel zinc plated

* possibility to make a different color

Installation nut

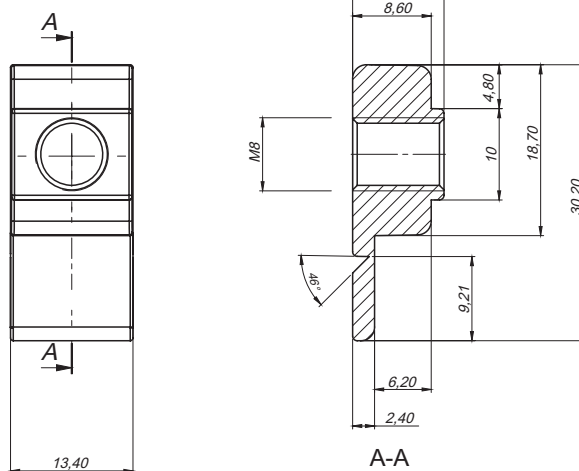

CAT. NUMBER	MATERIAL
4.501.001	ZAMAK

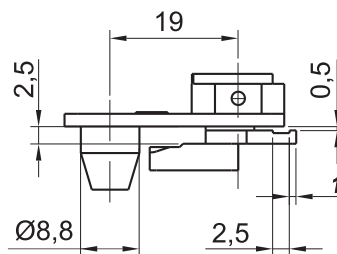
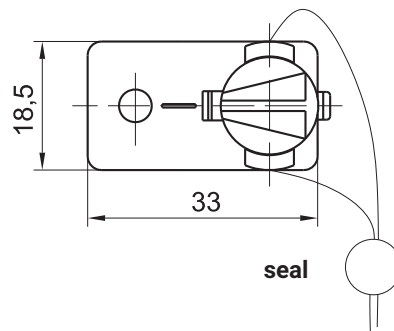

CAT. NUMBER	NAME	MATERIAL
4.417.001	Holder with seal	Polyamide

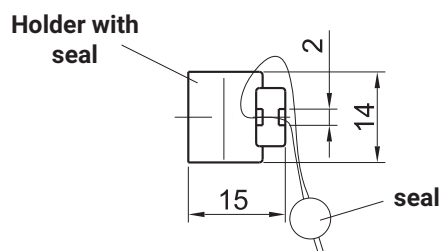
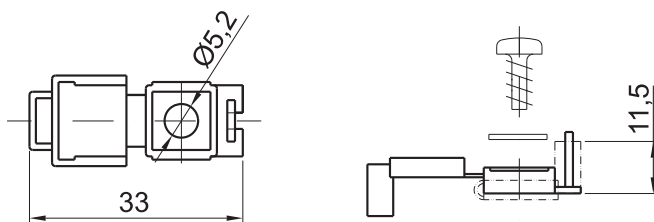

CAT. NUMBER	NAME	MATERIAL
4.416.001	Holder with seal	Polyamide

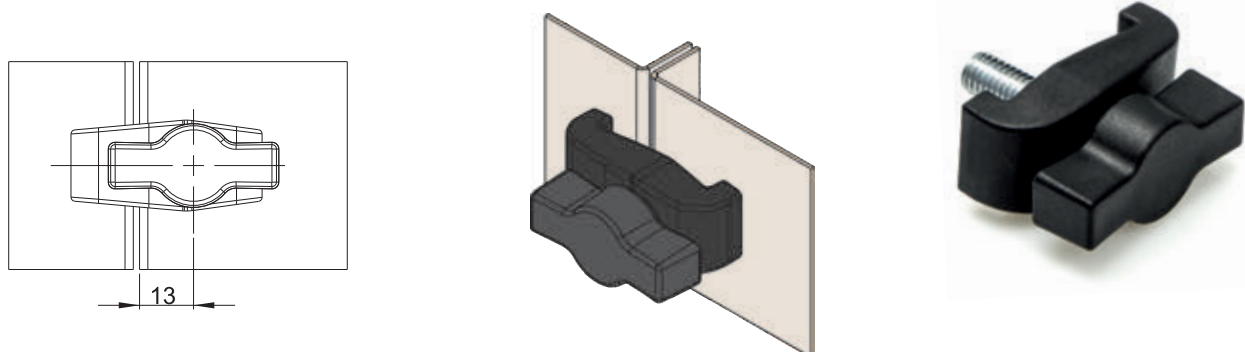

CAT. NUMBER	NAME	MATERIAL
4.411.001	Tommy screw	Polyamide-PA6 GF30 RAL/Steel zinc plated

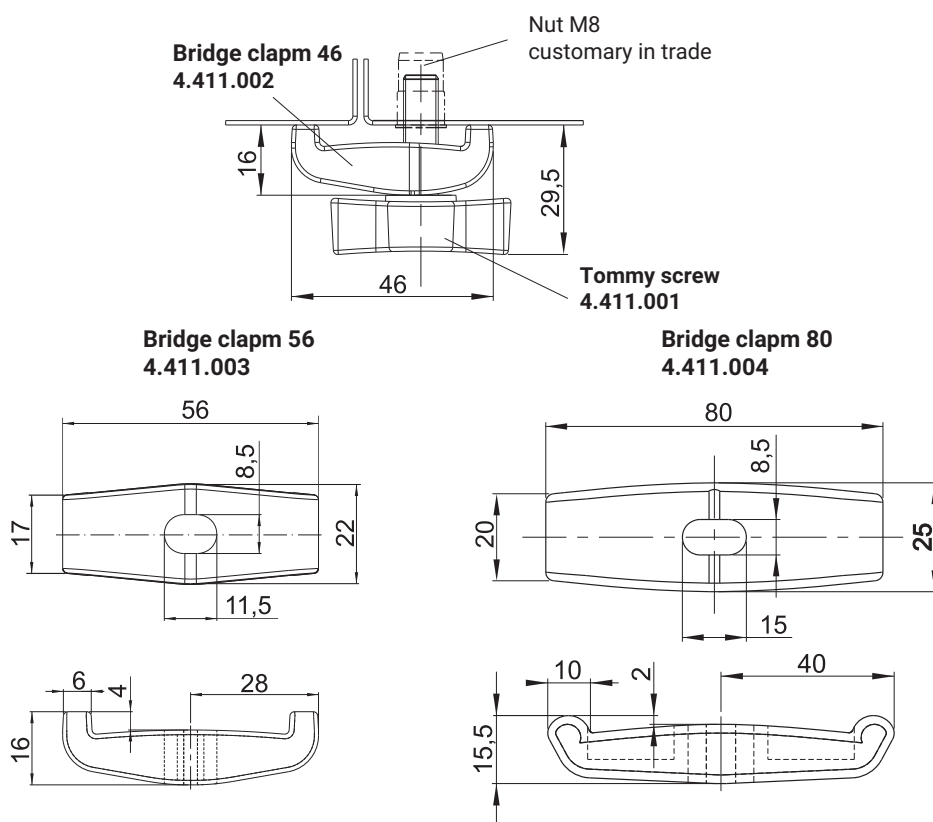

CAT. NUMBER	NAME	MATERIAL
4.411.002	Bridge clamp 46	Polyamide PA6 Gf30
4.411.003	Bridge clamp 56	
4.411.004	Bridge clamp 80	

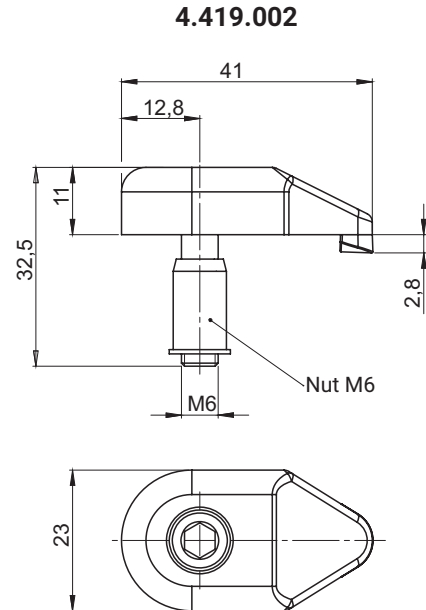
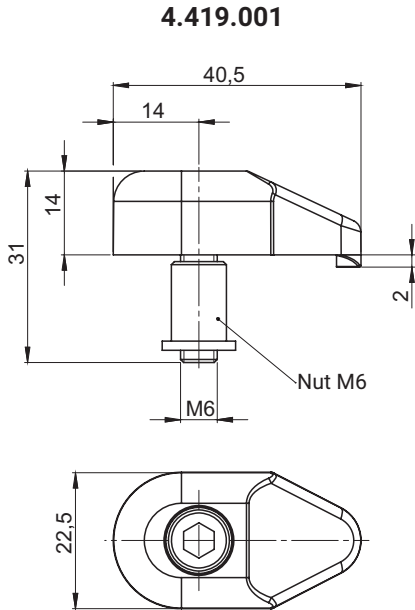

CATALOGUE NO.	DETAL	MATERIAL	FINISH [C]			
			Nickel	Zink plated	RAL 9005	RAL 7035
4.419.001-X	Metal bridge clamp	ZAMAK	01	02	03	04
4.419.002	Plastic bridge clamp	Polyamide	RAL 9005			

Connector 4.429.001

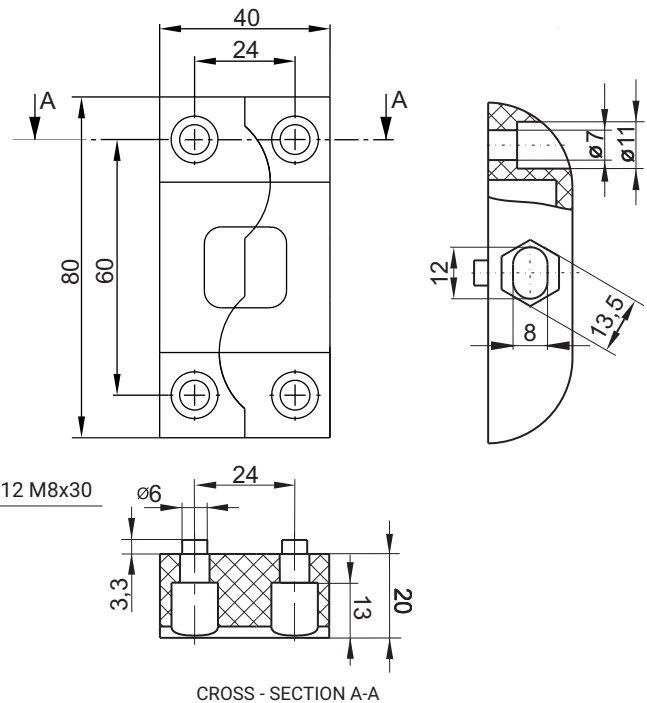
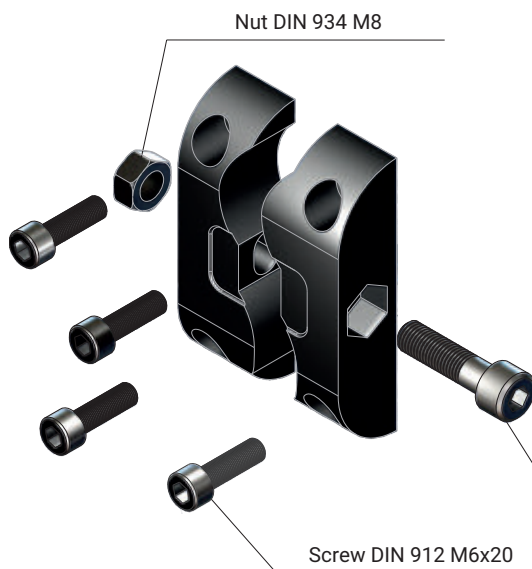

NAME	MATERIAL	FINISH [C]
		RAL 9005
Connector 4.429.001	Polyamide - PA6 GF30	07

ADJUSTABLE FEET

4.431.001

4.431.002

4.431.003

4.431.008

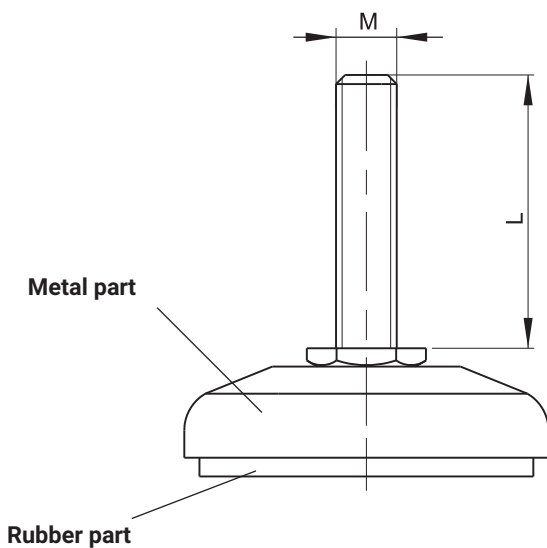
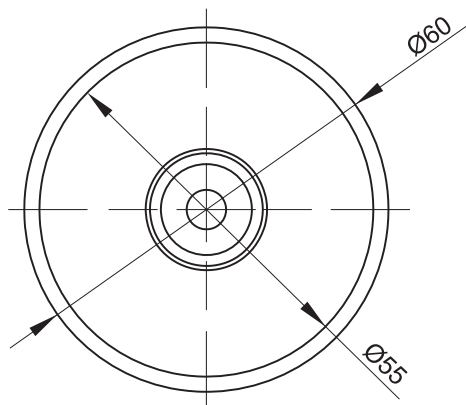

CAT. NUMBER	DIMENSION		NAME	MATERIAL
	M	L		
4.431.001	10	45	Adjustable foot	Steel zinc plated, Rubber
4.431.001SN	10	45	Adjustable foot	Stainless steel, Rubber
4.431.002	12	45	Adjustable foot	Steel zinc plated, Rubber
4.431.002SN	12	45	Adjustable foot	Stainless steel, Rubber
4.431.003	10	100	Adjustable foot	Steel zinc plated, Rubber
4.431.003SN	10	100	Adjustable foot	Stainless steel, Rubber
4.431.008	12	100	Adjustable foot	Steel zinc plated, Rubber
4.431.008SN	12	100	Adjustable foot	Stainless steel, Rubber
4.431.009	10	150	Adjustable foot	Steel zinc plated, Rubber
4.431.009SN	10	150	Adjustable foot	Stainless steel, Rubber
4.431.010	12	150	Adjustable foot	Steel zinc plated, Rubber
4.431.010SN	12	150	Adjustable foot	Stainless steel, Rubber

4.510.001

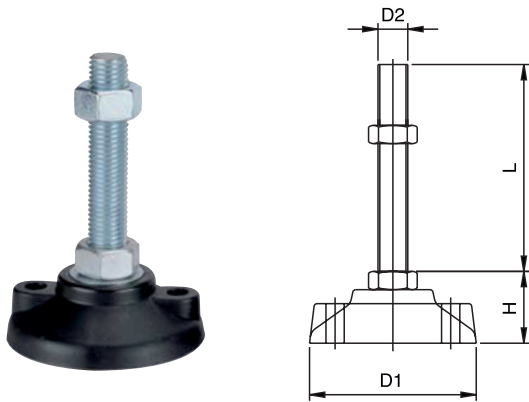

NAME	COMPONENTS			MATERIAL	
Adjustable foot	Screw			Steel zinc plated	
	Base			Polyamide	
CAT. NUMBER	D1	D2	H	L	LOAD
4.510.001.XXX	100	M16	42	100,150, 200,250	600kg
4.510.002.XXX		M20	46	75,100,150, 200,250	800kg
4.510.003.XXX		5/8"	43	100,150	600kg
4.510.004.XXX		3/4"	45	100,150	800kg
4.510.005.XXX	65	M16	42	100,150	600kg
4.510.006.XXX		M20	46	100,150	800kg

: where XXX=L

4.511.001

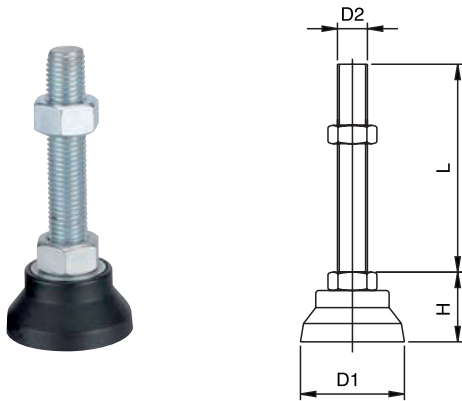

NAME	COMPONENTS			MATERIAL	
Adjustable foot	Screw			Steel zinc plated	
	Base			Polyamide	
CAT. NUMBER	D1	D2	H	L	LOAD
4.511.001.XXX	65	M16	42	100,150, 200,250	600kg
4.511.002.XXX		M20	46	75,100,150, 200,250	800kg
4.511.003.XXX		5/8"	43	100,150	600kg
4.511.004.XXX		3/4"	45	100,150	800kg
4.511.005.XXX		M16	42	100,150	600kg
4.511.006.XXX		M20	46	100,150	800kg

: where XXX=L

4.512...

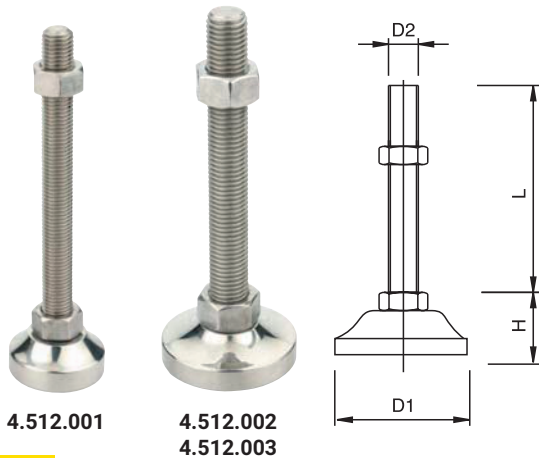

4.512.001

4.512.002
4.512.003

NAME	COMPONENTS			MATERIAL	
Adjustable foot	Screw			Stainless steel 304	
	Base			Stainless steel 304	
CAT. NUMBER	D1	D2	H	L	LOAD
4.512.001.XXX	50	M16	31	100,150	1500kg
4.512.002.XXX	70	M16	31	100,150	1500kg
4.512.003.XXX		M20	35	100,150	2000kg

: where XXX=L

4.513.001

NAME	COMPONENTS			MATERIAL	
Adjustable foot	Screw		Steel zinc plated		
	Base		Polyamide		
CAT. NUMBER	D1	D2	H	L	LOAD
4.513.001.XXX	70	M16	42	100,150, 200,250	600kg
4.513.002.XXX		M20	46	75,100,150, 200,250	800kg
4.513.003.XXX		5/8"	43	100,150	600kg
4.513.004.XXX		3/4"	45	100,150	800kg
4.513.005.XXX		M16	42	100,150	600kg
4.513.006.XXX		M20	46	100,150	800kg

: where XXX=L

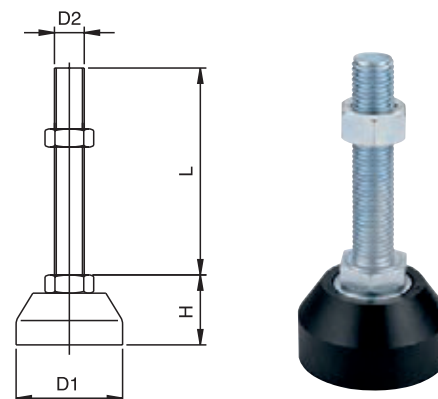

4.514.001

NAME	COMPONENTS			MATERIAL	
Adjustable foot	Screw		Steel zinc plated		
	Base		Polyamide		
CAT. NUMBER	D1	D2	H	L	LOAD
4.514.001.XXX	55	M12	26	50,75 100,150,	300kg
4.514.002.XXX		M16	28	70,100,150,	500kg
4.514.003.XXX		1/2"	27	75,100,150	300kg
4.514.004.XXX		5/8"	29	75,100,150	500kg
4.514.005.XXX	75	M16	30	100,150	500kg
4.514.006.XXX		5/8"	31	100,150	500kg

: where XXX=L

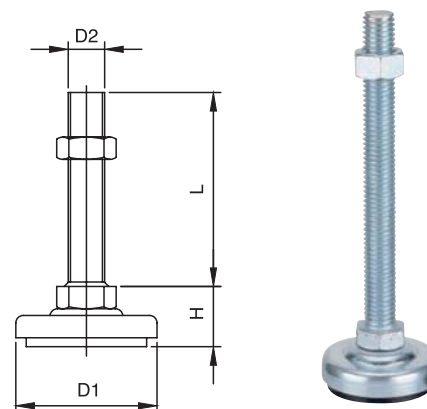

4.515.001

NAME	COMPONENTS			MATERIAL	
Adjustable foot	Screw		Steel zinc plated		
	Base		Steel zinc plated with rubber from below		
CAT. NUMBER	D1	D2	H	L	LOAD
4.515.001.XXX	40	M10	20	50,100	200kg
4.515.002.XXX		M12	23	50,100	300kg
4.515.003.XXX	55	M12	26	50,75 100,150,	300kg
4.515.004.XXX		M16	28	70,100,150,	500kg
4.515.005.XXX		1/2"	27	75,100,150	300kg
4.515.006.XXX	75	5/8"	29	75,100,150	500kg
4.515.007.XXX		M16	30	100,150	500kg
4.515.008.XXX		5/8"	31	100,150	500kg

: where XXX=L

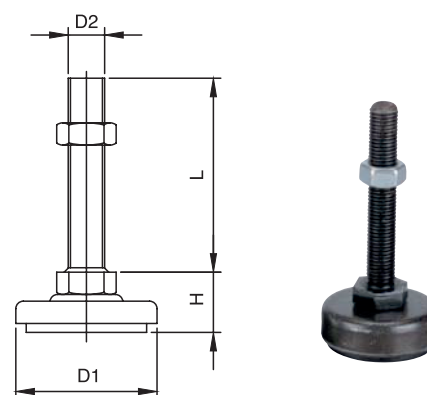

TX-102-2

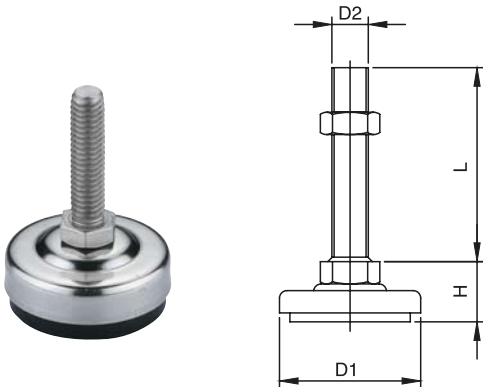
4.516.001

NAME	COMPONENTS			MATERIAL	
Adjustable foot	Screw			Steel zinc plated	
	Base			Steel zinc plated with rubber from below	
CAT. NUMBER	D1	D2	H	L	LOAD
4.516.001.XXX	40	M10	21	100,150	200kg
4.516.002.XXX		M12	23	100,150	300kg
4.516.003.XXX		1/2"	23	100,150	300kg
4.516.004.XXX	60	M12	30	100,150	300kg
4.516.005.XXX		M16	32	100	500kg
4.516.006.XXX		1/2"	30	50,100	300kg
4.516.007.XXX		5/8"	32	100	500kg

: where XXX=L

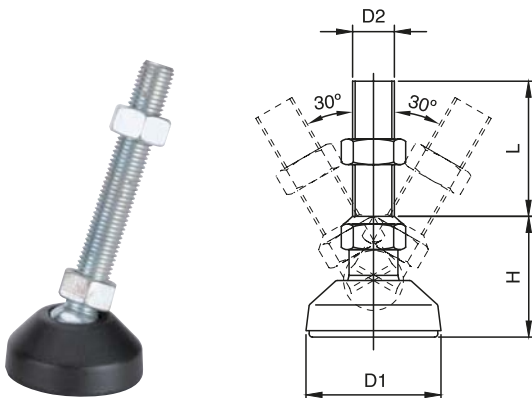
4.517.001
with movable screw

NAME	COMPONENTS			MATERIAL	
Adjustable foot	Screw			Steel zinc plated	
	Base			Polyamide	
CAT. NUMBER	D1	D2	H	L	LOAD
4.517.001.XXX	65	M16	39	150	300kg
4.517.002.XXX		M16	39	100	300kg
4.517.003.XXX		5/8"	39	100	300kg

: where XXX=L

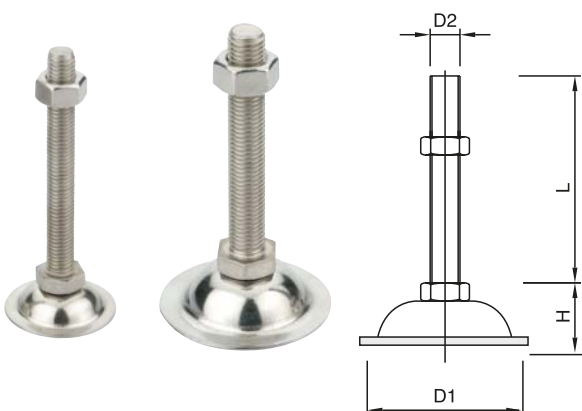
4.518.001

NAME	COMPONENTS			MATERIAL	
Adjustable foot	Screw			Stainless steel 304	
	Base			Stainless steel 304	
CAT. NUMBER	D1	D2	H	L	LOAD
4.518.001.XXX	50	M10	18	50, 100	150kg
4.518.002.XXX		M12	20	50, 75, 100	200kg
4.518.003.XXX		1/2"	20	50, 75, 100	200kg
4.518.004.XXX	70	M12	27	50, 75, 100, 150	300kg
4.518.005.XXX		M16	30	50, 75, 100, 150	400kg
4.518.006.XXX		1/2"	27	50, 75, 100	300kg
4.518.007.XXX		5/8"	30	100	400kg

: where XXX=L

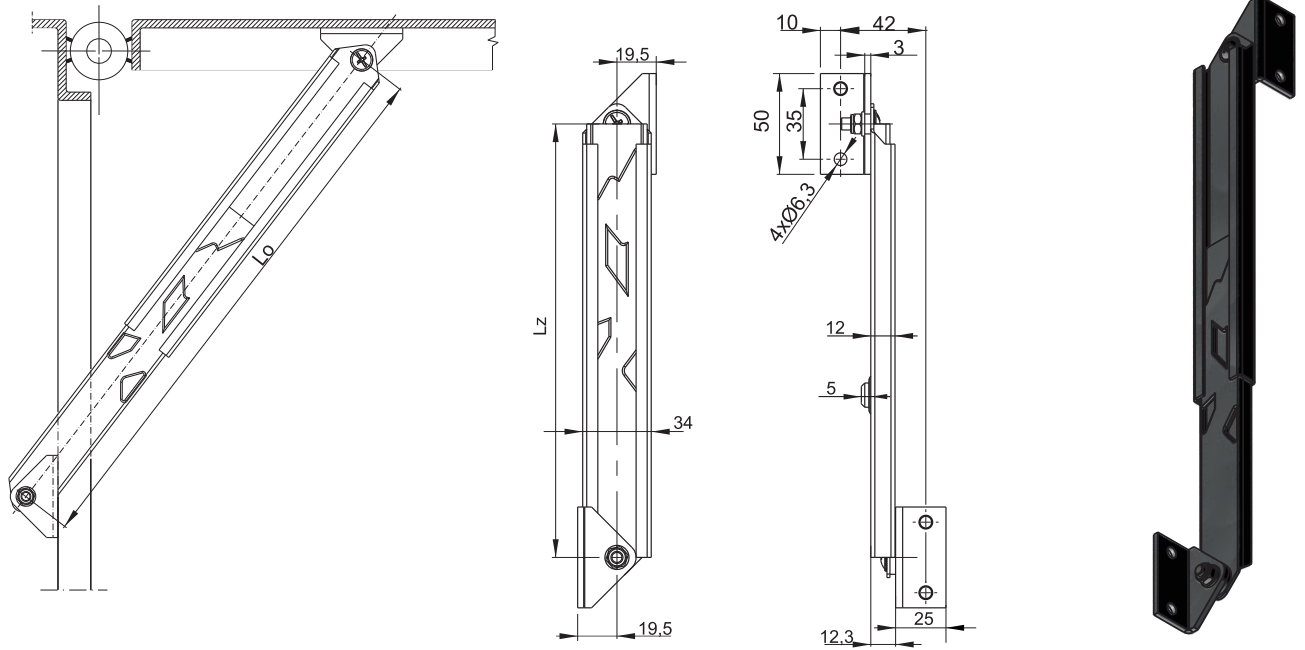

CAT. NUMBER	NAME	MATERIAL	Lz - closed	Lo - open
4.401.101	Telescopic blockade	Steel zinc plated	215	335
4.401.102			395	695

Version A

Version B

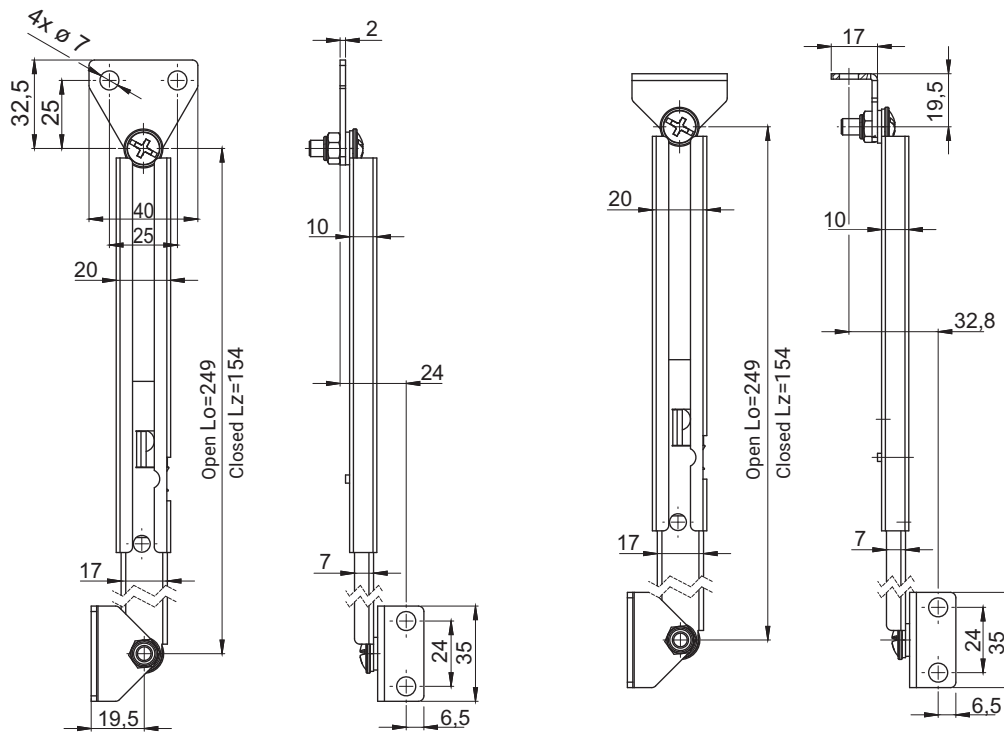

CATALOGUE NO.	VERSION	DETAL	VERSION	MATERIAL
4.401.105	A	Telescopic blockade	Left	Steel zinc plated
4.401.106			Right	
4.401.107	B		Left	
4.401.108			Right	

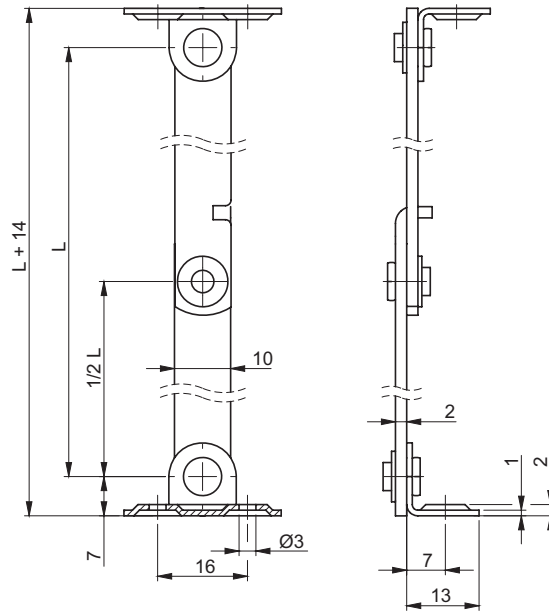

CATALOGUE NUMBER	Dimension L [mm]	MATERIAL
4.401.200	292	Steel zinc plated
4.401.201	252	
4.401.202	202	
4.401.203	135	
4.401.200SN	292	Stainless steel
4.401.201SN	252	
4.401.202SN	202	
4.401.203SN	135	

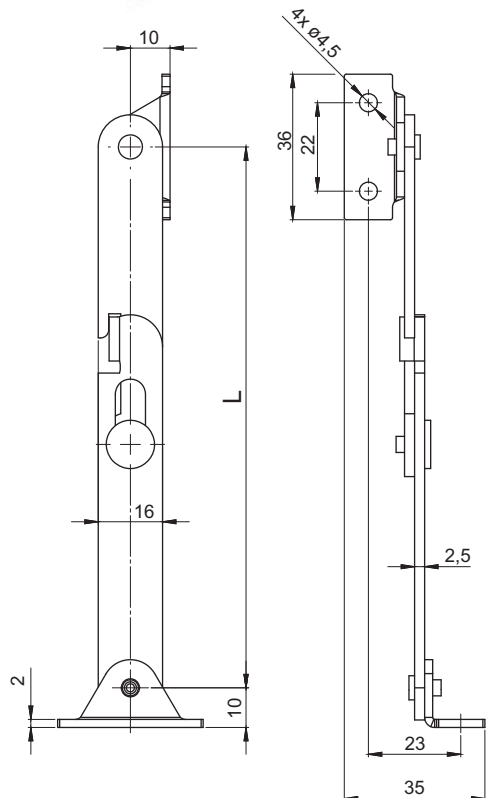

Left version

Right version

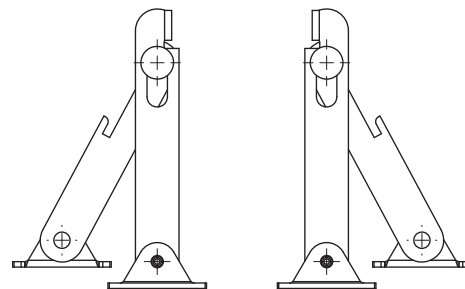

CATALOGUE NO.	VERSION	L	MATERIAL
4.401.301	Right	290	Steel zinc plated
4.401.301SN			Stainless steel
4.401.302	Left	202	Steel zinc plated
4.401.302SN			Stainless steel
4.401.303	Right	135	Steel zinc plated
4.401.303SN			Stainless steel
4.401.304	Left	202	Steel zinc plated
4.401.304SN			Stainless steel
4.401.305	Right	135	Steel zinc plated
4.401.305SN			Stainless steel
4.401.306	Left	135	Steel zinc plated
4.401.306SN			Stainless steel

Screw 4.430. ...

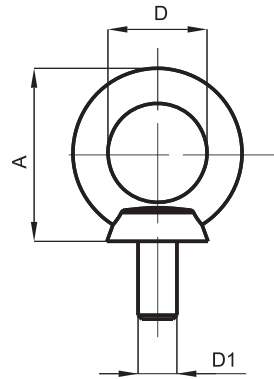

Version	D1	A	D
4.430.001	M8	37	ø20,5
4.430.002	M10	44,5	ø25,5
4.430.003	M12	53,5	ø29,8
4.430.004	M14	64	ø34,5
4.430.005	M16	64	ø34,5

CAT. NUMBER	MATERIAL
4.430....	Steel zinc plated

BOX HOLDER
4.410....

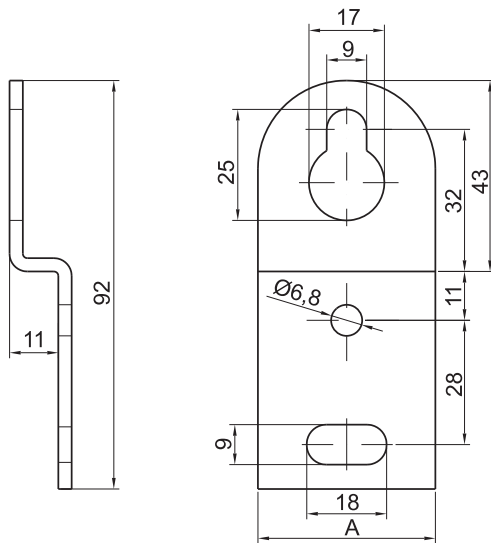

TRAPEZIUM NUT
4.409....

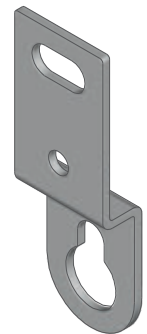
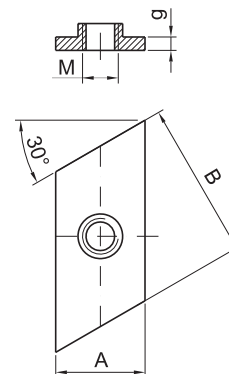

BOX HOLDER
LOWER

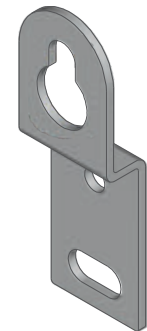

BOX HOLDER
UPPER

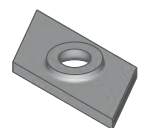

CAT. NUMBER	NAME	MATERIAL	A	B	G	M
4.409.003	Trapezium nut	Steel zinc plated	20	35	3	M8
4.409.002			15	20	3	M8
4.409.001			12	30	3	M6
4.410.001	Box holder		30	2,5	-	-
4.410.002			40	3	-	-

stainless steel

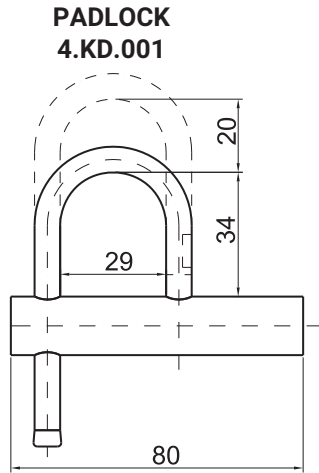

PADLOCK SN
4.KDSN.001

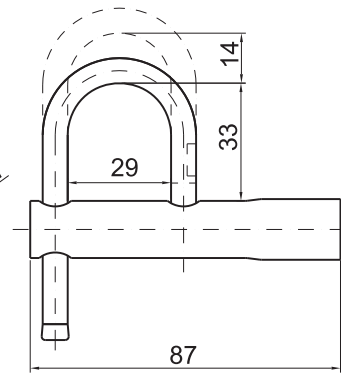

PADLOCK SN
4.KDZN.001

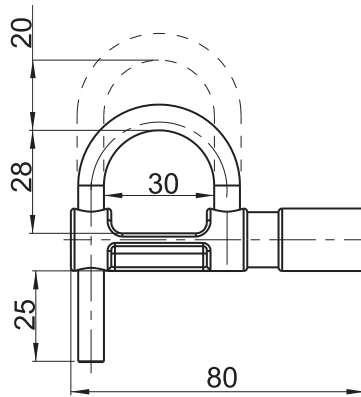
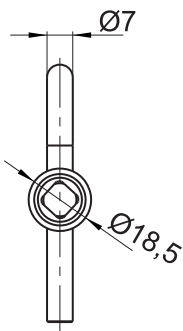

SELF-LOCKING PADLOCK
4.KDZN.002

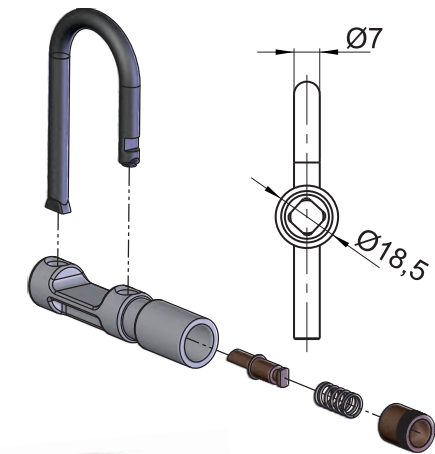
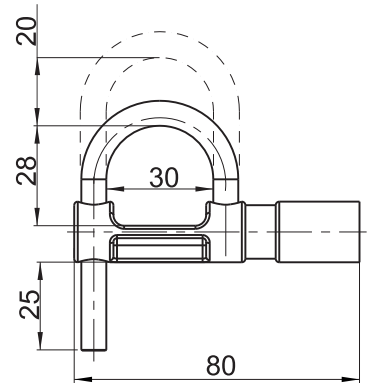
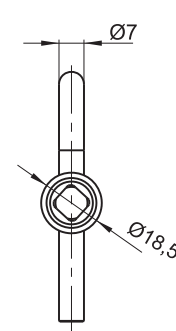

KEY
4.KDZN.002.06

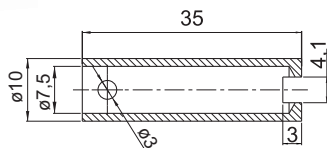

INSERTS [X]

4.KD.001, 4.KDSN.001, 4.KDZN.001

T9	KW8	KW6	C9

CAT. NUMBER	NAME	MATERIAL
4.KD.001	Padlock KD	Steel zinc plated
4.KDSN.001	Padlock KDSN	Stainless steel- 1.4301
4.KDZN.001	Padlock KDZN	Zamak - zinc plated
4.KDZN.002	Self-locking padlock KDZN	
4.KDZN.002.06	Key for padlock KDZN002	Steel zinc plated

How to order :

Type of lock
Type of insert [X]

4.KDZN.001 — KW8



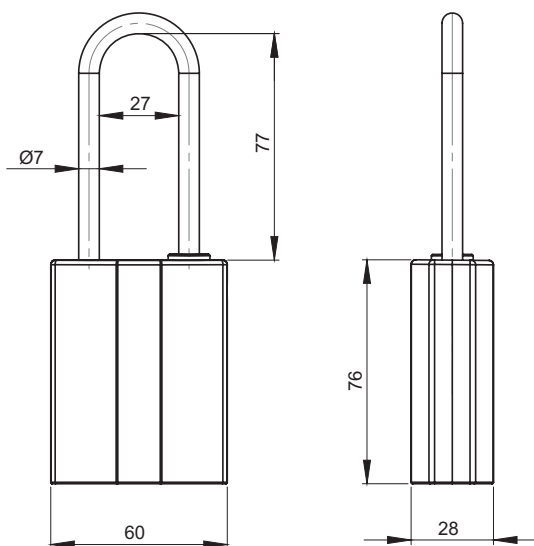

CATALOGUE NUMBER	COMPONENTS	MATERIAL	FINISH [C]
			RAL9005
4.KDZN.100	Body	ZAMAK	04
	Shackle	Steel zinc plated	-

Padlock is equipped with a special shaped insert type D13.

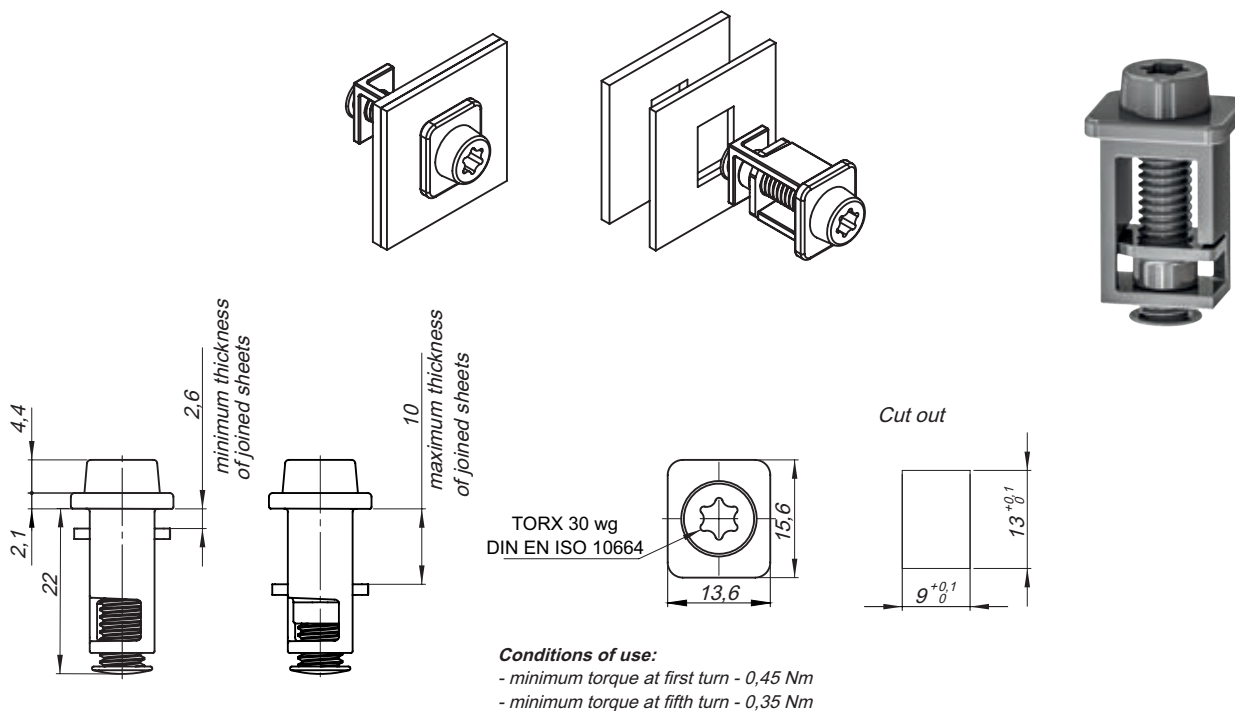

CATALOGUE NUMBER	COMPONENTS	MATERIAL
4.600.001	Body	Zn1 zinc plated
	Screw, Nut	Steel zinc plated

Frame connector **4.422.001**

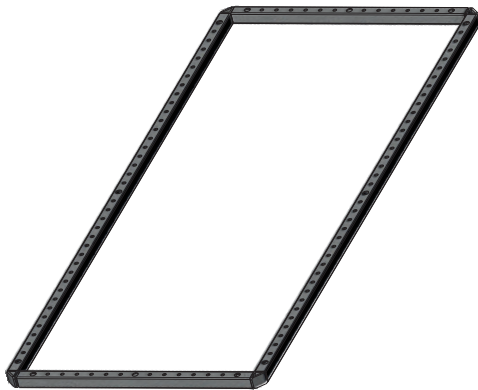
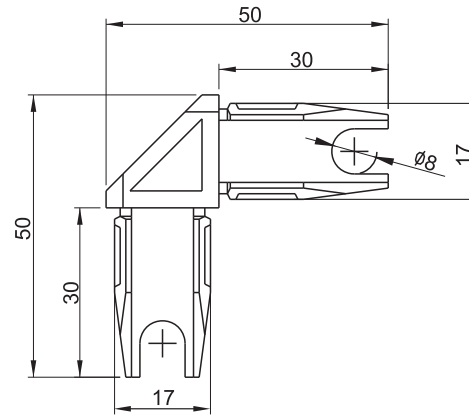
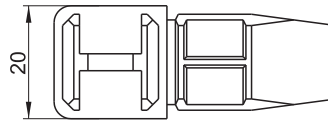

Profile

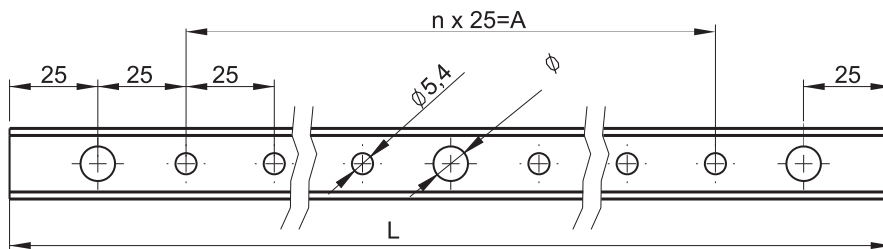
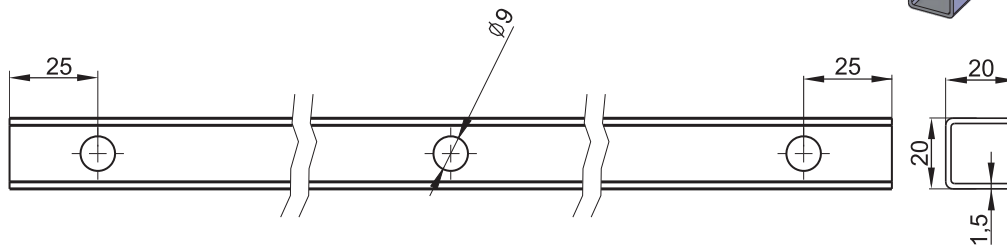
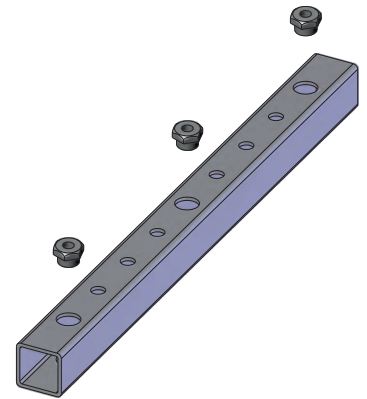

CAT. NUMBER	MATERIAL	NAME	DIMENSION L	nx25=A
4.422.001	Zamak-zinc plated	Frame connector	-	-
4.422.002	Steel zinc plated	Nut M6x	-	-
4.450.01.1850	Steel zinc plated	Profile	1850	70 x 25 = 1750
4.450.01.1650			1650	62 x 25 = 1550
4.450.01.1450			1450	54 x 25 = 1350
4.450.01.1050			1050	38 x 25 = 950
4.450.01.0600			600	20 x 25 = 500
4.450.01.0400			400	12 x 25 = 300

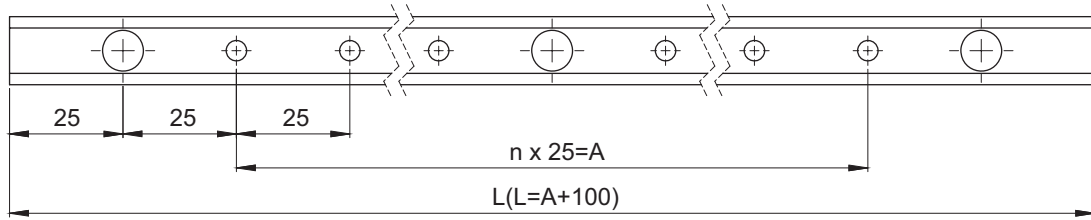

Version 001

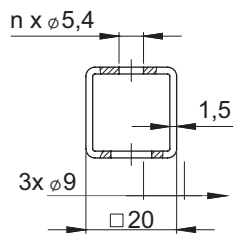

Version 002

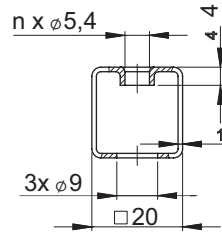

Version 003

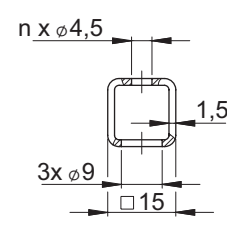

CATALOGUE NO.			DIMENSION L	n x 25 = A	MATERIAL
VERSION					
001	002	003			
-	4.450.002.1900	-	1900	72 x 25 = 1850	Steel zinc plated
4.450.001.1850	4.450.002.1850	-	1850	70 x 25 = 1750	
4.450.001.1650	4.450.002.1650	-	1650	62 x 25 = 1550	
4.450.001.1450	4.450.002.1450	-	1450	54 x 25 = 1350	
4.450.001.1050	4.450.002.1050	-	1050	38 x 25 = 950	
-	-	4.450.003.700	700	24 x 25 = 600	
4.450.001.0600	-	-	600	20 x 25 = 500	
4.450.001.0400	-	-	400	12 x 25 = 300	
-	-	4.450.003.350	350	10 x 25 = 250	

Pocket A4 **4.420.001**

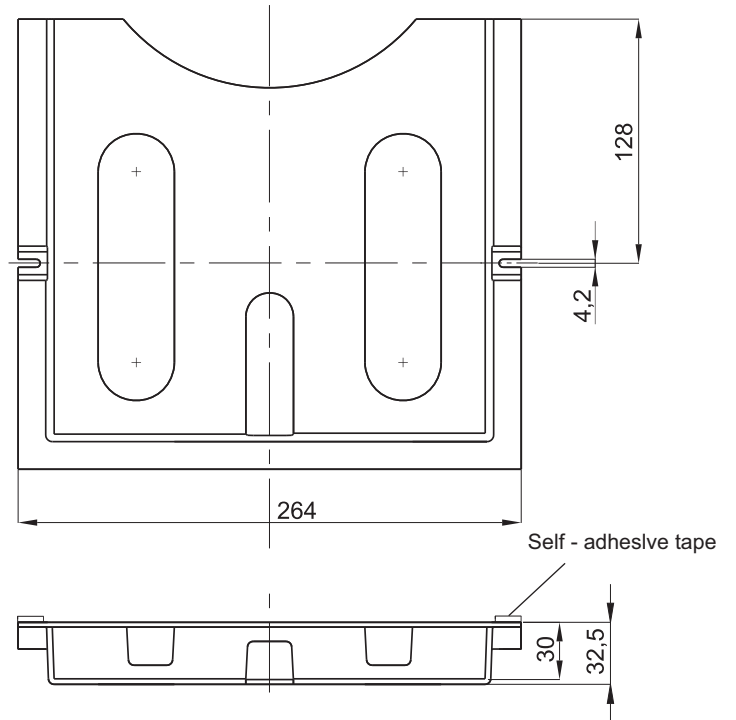

CATALOGUE NUMBER	NAME	MATERIAL	FINISH [C]
			RAL 7035
4.420.001	Document pocket A4	ABS	08

Pocket A6 **4.420.002**

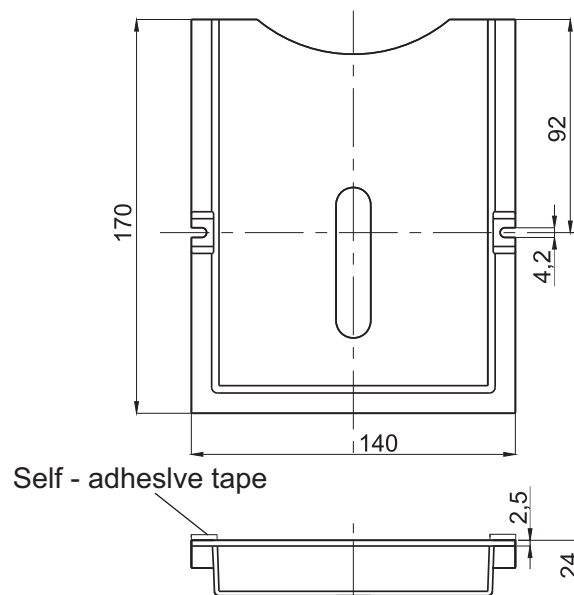

CATALOGUE NUMBER	NAME	MATERIAL	FINISH [C]
			RAL 7035
4.420.002	Document pocket A6	ABS	08

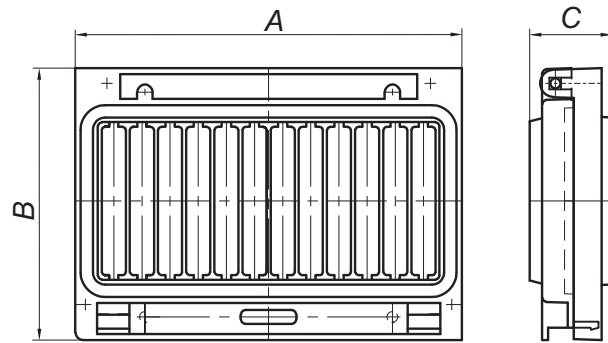

L.p.	A	B	C
4.110	88,5	88	27
4.111	125	88	27
4.112	161,5	88	27
4.113	234	88	27
4.114	254	210	27

WINDOW 117 x 117

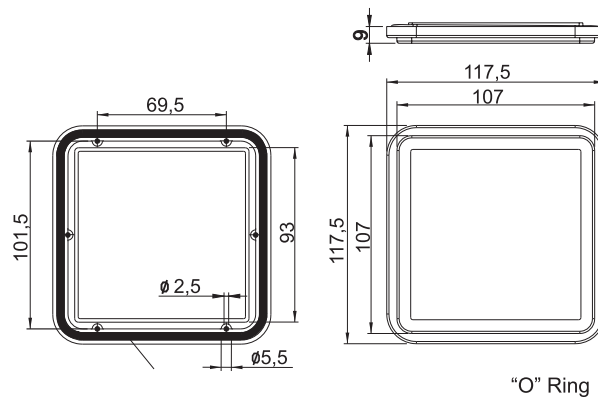

CAT. NUMBER	NAME	MATERIAL
4.423.001	Window 117 x 117	Polycarbonate

WINDOW 151 x 190

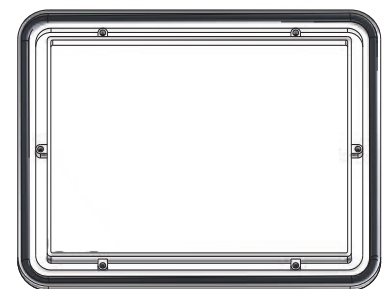
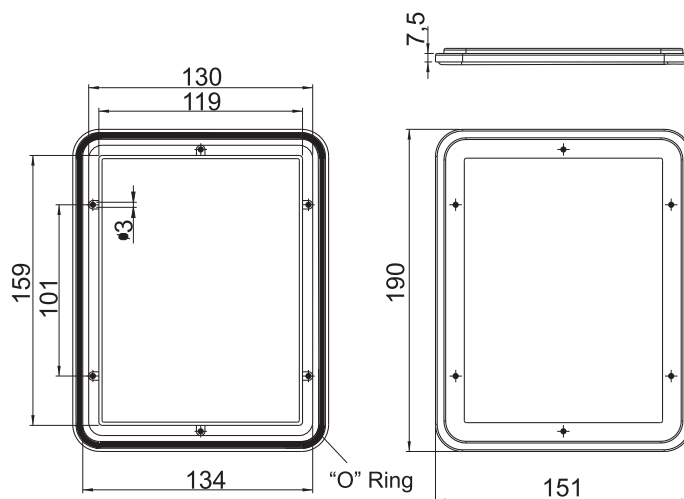

CAT. NUMBER	NAME	MATERIAL
4.423.002	Window 151 x 190	Polycarbonate

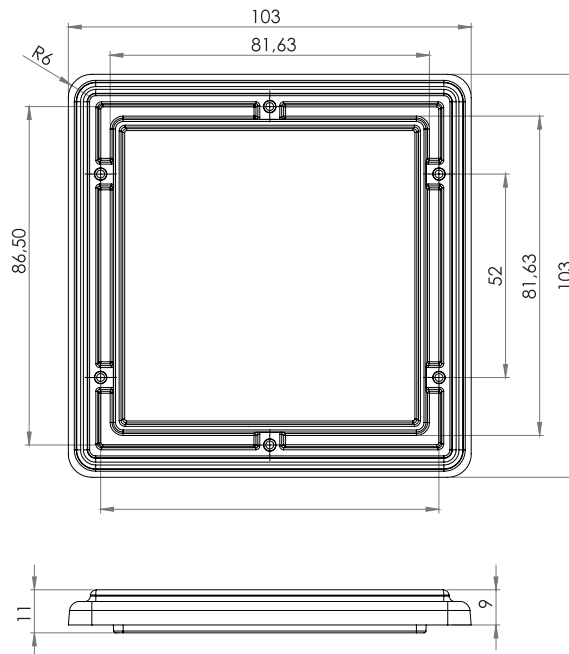

CAT. NUMBER	COLOUR	MATERIAL
4.423.003	Transparent	Polycarbonate

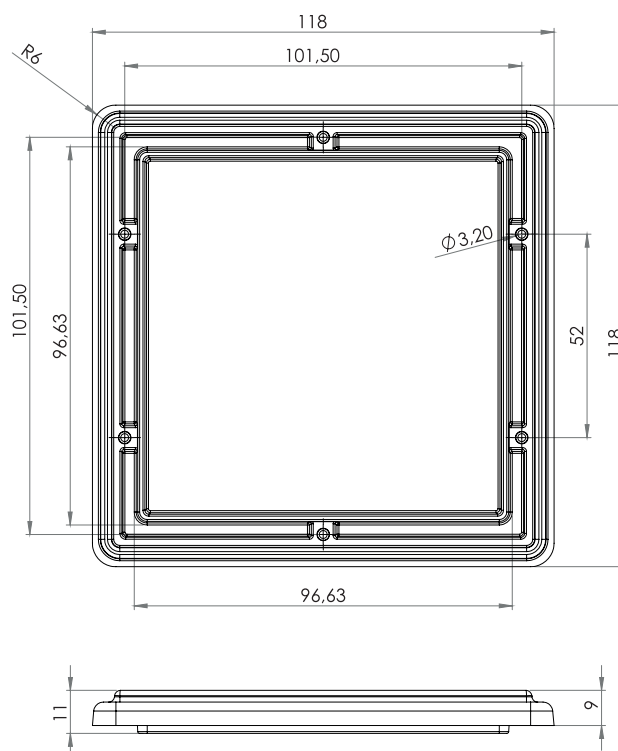

CAT. NUMBER	COLOUR	MATERIAL
4.423.004	Transparent	Polycarbonate

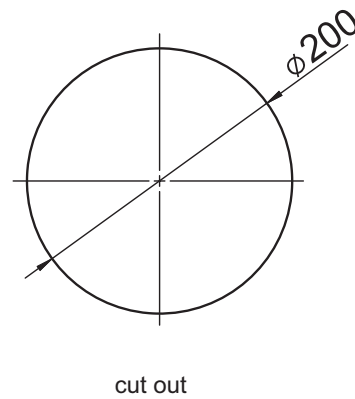
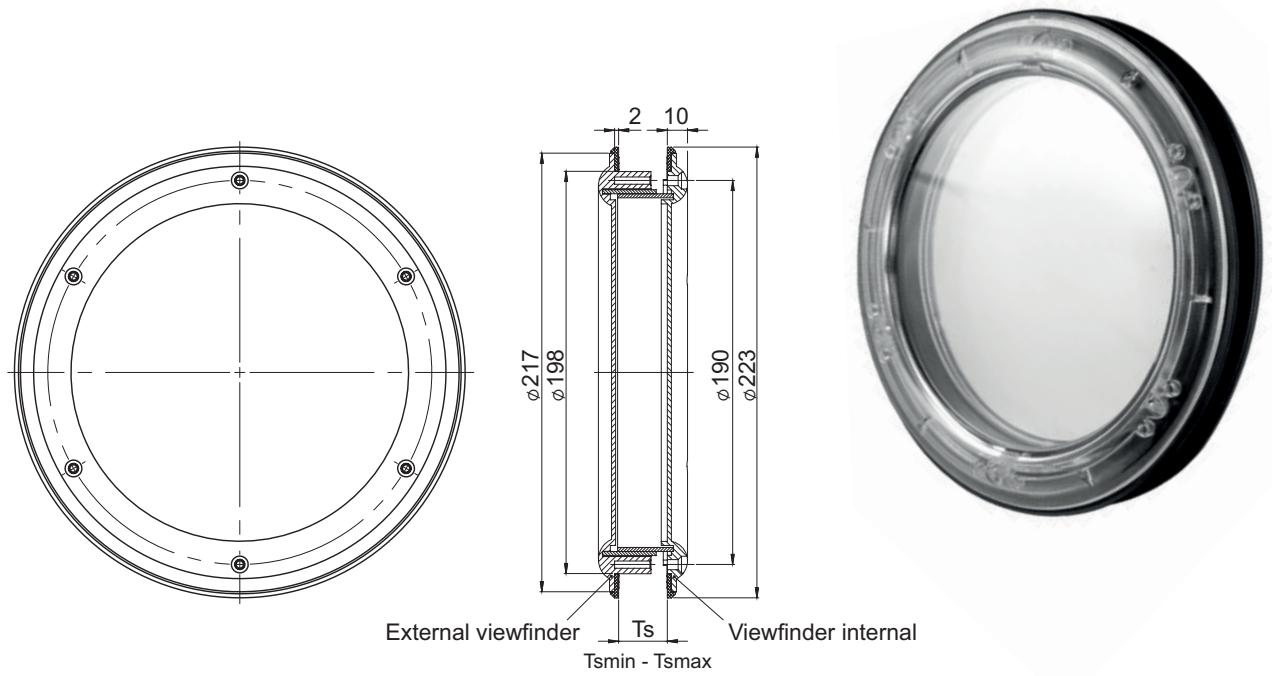

CATALOGUE NO.	DIMENSION T_s	DETAL	COMPONENTS	MATERIAL
4.425.001	19 - 35	Inspection window	Viewfinder	Polycarbonate
4.425.002	39 - 53		Gasket	EPDM
4.425.003	54 - 65		Adjusting ring	Poliamid
4.425.004	70 - 90			
4.425.005	95 - 110			

$T_{smin} - T_{smax}$ - the range of thickness adjustment of inspection window

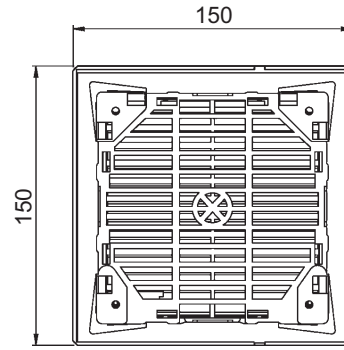
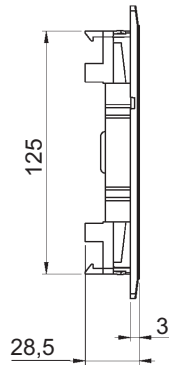

CAT. NUMBER	MATERIAL	FINISH [C]	
		RAL 9005	RAL 7035
4.107.001	ABS	07	08

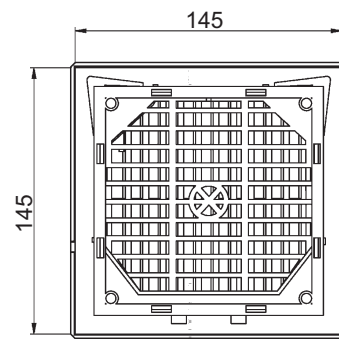
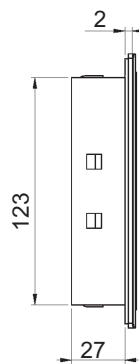

CAT. NUMBER	MATERIAL	FINISH [C]	
		RAL 9005	RAL 7035
4.108.001	ABS	07	08

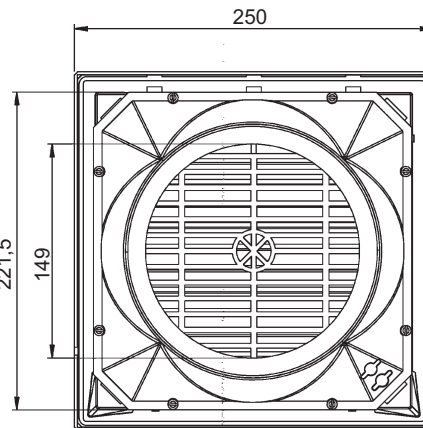
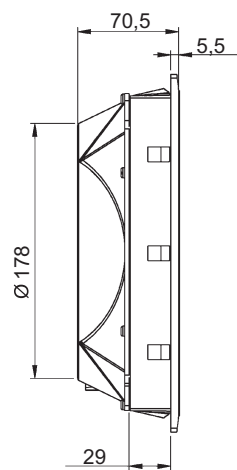
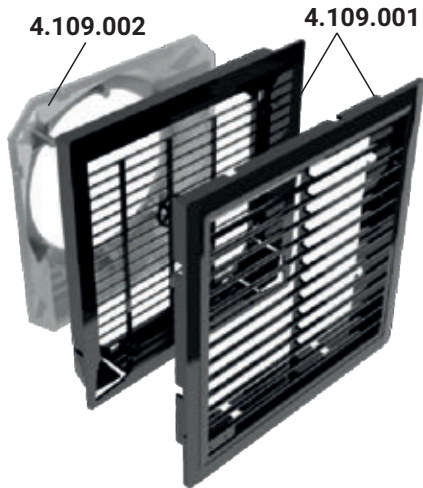

CAT. NUMBER	MATERIAL	FINISH [C]	
		RAL 9005	RAL 7035
4.109.001	ABS	07	08
4.109.002	ABS		

How to order:

Catalogue number

Finish

4.107.001

C

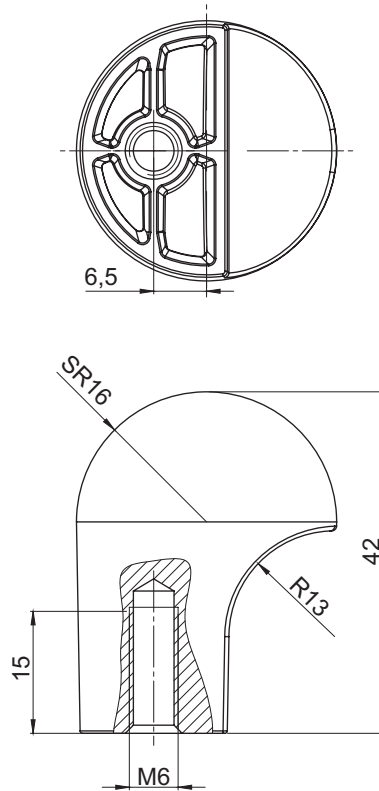

CATALOGUE NO.	DETAL	MATERIAL	FINISH [C]	
4.250.001	Handle	ZAMAK 5	Chrome	01
			Brass	12
			No coating	0

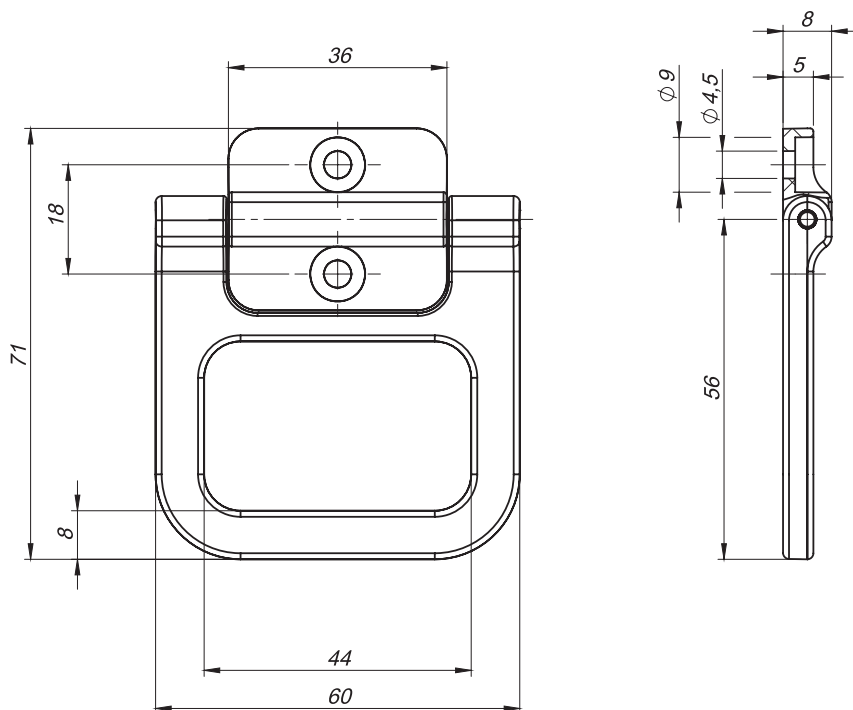

CATALOGUE NO.	COMPONENTS	MATERIAL	FINISH [C]	
			RAL 9005	
4.444.005	Holder, Base	Polyamide	07	
	Pin	Steel zinc plated	-	

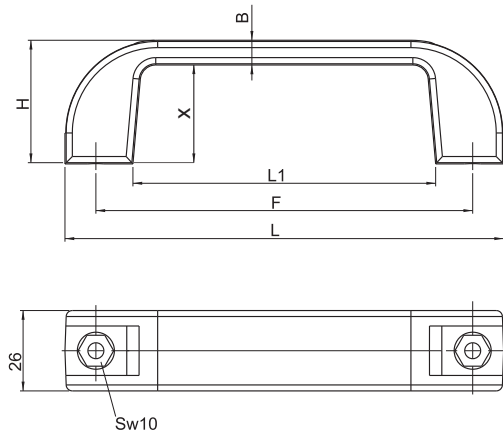

CAT. NUMBER	DIMENSION						MATERIAL	FINISH [C]
	L	F	L1	H	B	X		RAL 9005
4.440.001	107	93,5	74	36	5,50	33	Polyamide GF30	07
4.440.002	134	114	88,5	45	10,50	34		
4.440.003	144	122	94	42	12	30		
4.440.004	150	131	108	45	7	38		
4.440.005	170	150	118	54	7	42		

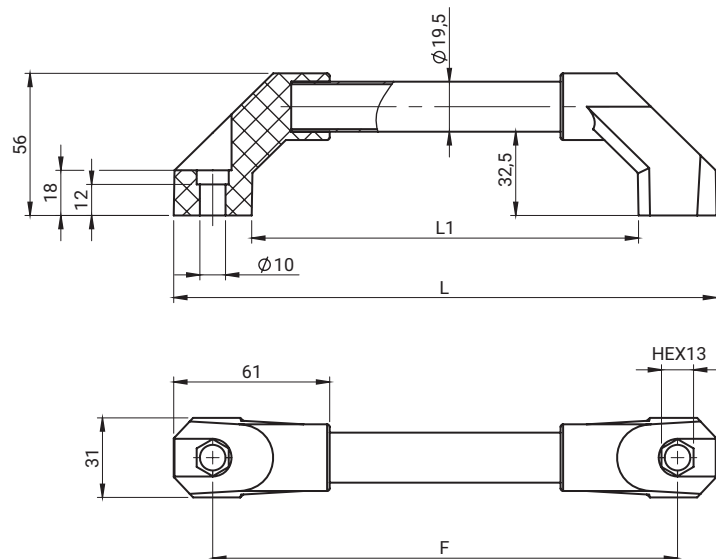

CAT. NUMBER	DIMENSION			MATERIAL	HOLDER FINISH [C]
	F	L	L1		RAL 9005
4.441.001	200	224	154	Holder Polyamide Handle Aluminum	07
4.441.002	300	324	254		
4.441.003	400	424	354		
4.441.004	500	524	454		

Handle PA 4.444.001

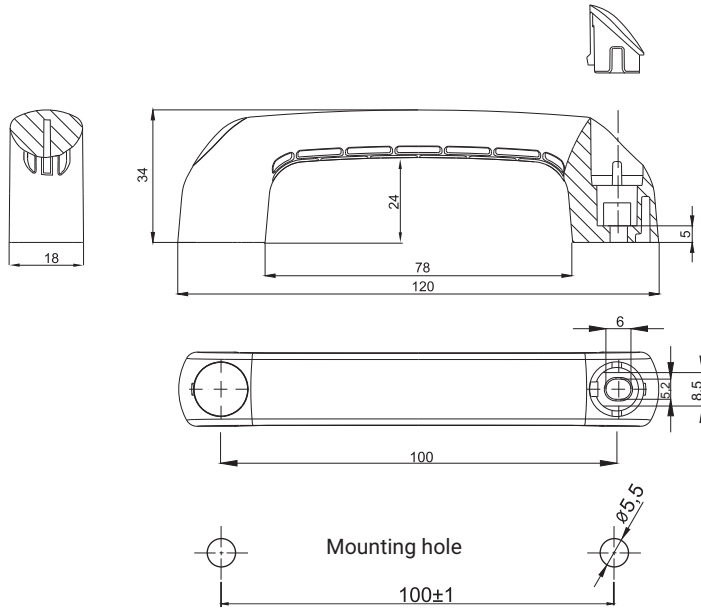

PLUG COLORS	
01	black
02	blue
03	red
04	green
05	yellow
06	grey

CAT. NUMBER	MATERIAL	LOAD CAPACITY
4.444.001...	Polyamide PA6 GF30 RAL 9005	54 kg

Note: handle colors on request

Handle PA 4.444.002

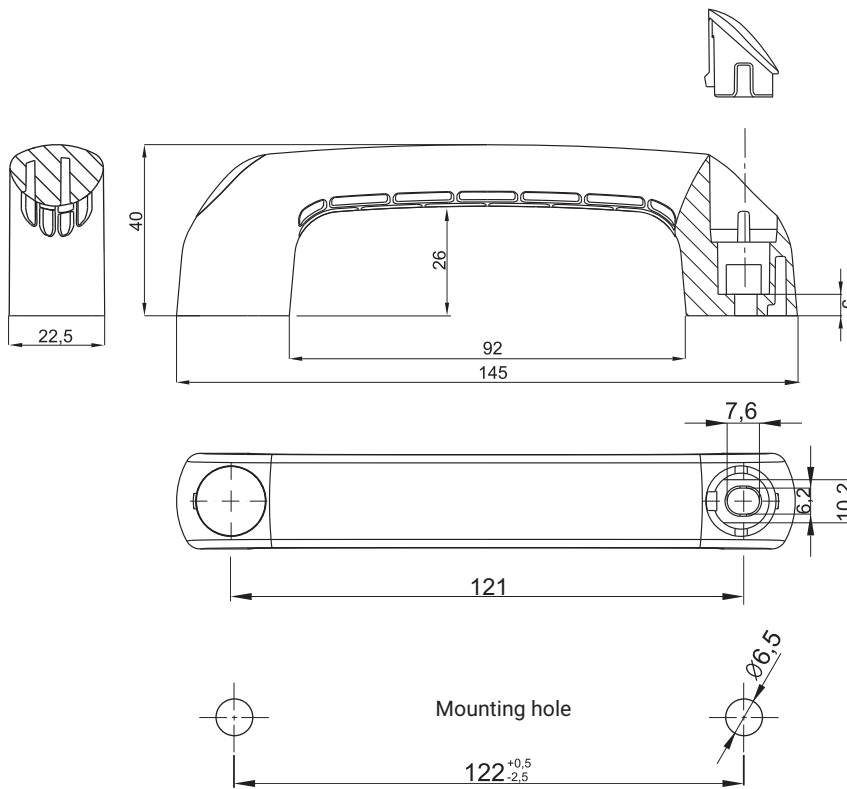

PLUG COLORS [C]	
01	black
02	blue
03	red
04	green
05	yellow
06	grey

Construction design allows to mount the handle into the holes with a spacing of 120mm

CAT. NUMBER	MATERIAL	LOAD CAPACITY
4.444.002...	Polyamide PA6 GF30 RAL 9005	54 kg

Note: handle colors on request

How to order:
 Catalogue number 4.444.001
 Plug color C

Mounting screws	4.444.001 M5	4.444.002 M6
	DIN 933	
	DIN 7984	
	DIN 965	
	DIN 84	

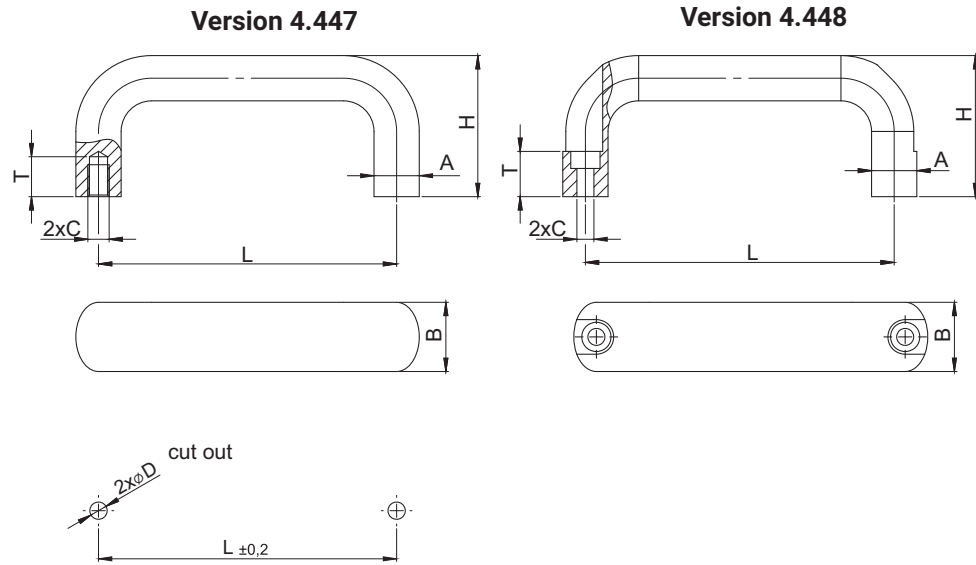

CATALOGUE NO.	DIMENSIONS							MATERIAL	FINISH					
	L	H	A	B	T	C	D							
VERSION 4.447														
4.447.001	100	47	13	20	10	M6	6,6	Aluminum	Natural					
4.447.002	112	49												
4.447.003	128	51												
4.447.004	160	51												
4.447.005	112	53	17	26	12	M8	9							
4.447.006	128	55												
4.447.007	160	57												
4.447.008	192	57												
4.447.009	300	57												
4.447.010	400	57												
4.447.101	100	47	13	20	10	M6	6,6	black plastic coating						
4.447.102	112	49												
4.447.103	128	51												
4.447.104	160	51												
4.447.105	112	53												
4.447.106	128	55												
4.447.107	160	57												
4.447.108	192	57												
4.447.109	300	57												
4.447.110	400	57												
4.447.301	100	50	13	20	10	M6	6,6	anodising						
4.447.302	112													
4.447.303	112								55	17	26	12	M8	9
4.447.304	128								50	13	20	10	M6	6,6
4.447.305	128								55	17	26	12	M8	9
4.447.306	160								50	13	20	10	M6	6,6
4.447.307	160								55	17	26	12	M8	9
4.447.308	192													
4.447.309	300													
4.447.310	400													
4.447.002 SN	112	49	13	20	10	M6	6,6	Stainless steel	Natural					
4.447.003 SN	128	51												
VERSION 4.448														
4.448.001	116	53	17	26	17	∅6,4	6,6	Aluminum	Natural					
4.448.002	132	55												
4.448.003	164	57												
4.448.004	196	57												
4.448.101	116	53	17	26	17	∅6,4	6,6	Aluminum	black plastic coating					
4.448.102	132	55												
4.448.103	164	57												
4.448.104	196	57												

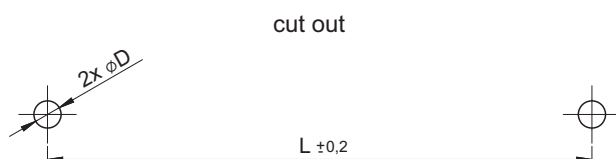
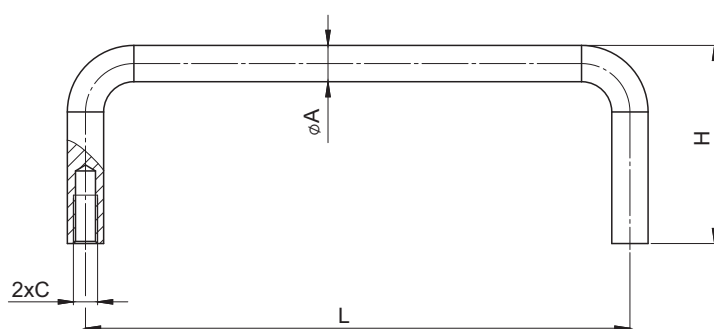

CATALOGUE NO.		DIMENSIONS				
Chrome plated steel	Stainless steel	L	A	H	C	D
4.446.001	4.446.001SN	70	6	32	M4	4,5
4.446.002	4.446.002SN	90	6	32	M4	4,5
4.446.003	4.446.003SN	102	6	32	M4	4,5
4.446.004	4.446.004SN	122	6	32	M4	4,5
4.446.005	4.446.005SN	138	6	32	M4	4,5
4.446.006	4.446.006SN	75	8	40	M5	6
4.446.007	4.446.007SN	100	8	32	M5	6
4.446.008	4.446.008SN	150	8	40	M5	6
4.446.009	4.446.009SN	90	9	32	M5	6
4.446.010	4.446.010SN	119	9	40	M5	6
4.446.011	4.446.011SN	135	9	32	M5	6
4.446.012	4.446.012SN	149	9	40	M5	6
4.446.013	4.446.013SN	155	9	32	M5	6
4.446.014	4.446.014SN	160	9	40	M5	6

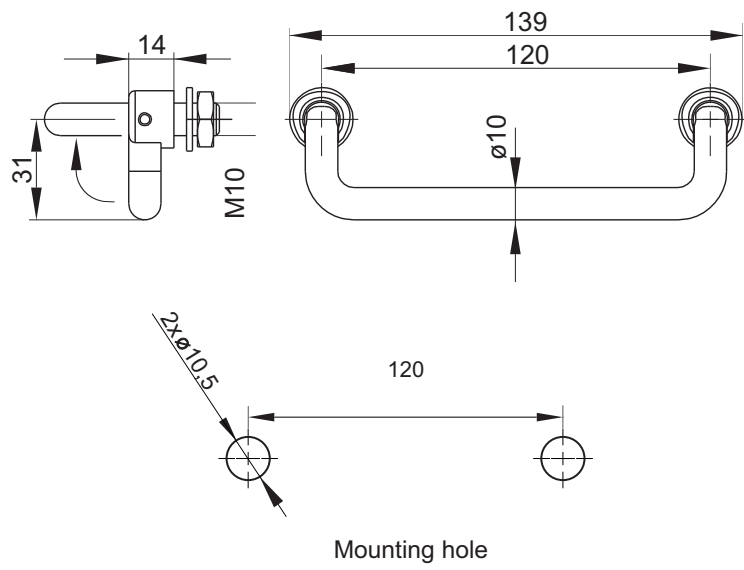

CAT. NUMBER	COMPONENTS	MATERIAL
4.444.003	Holder, Base	Stainless steel

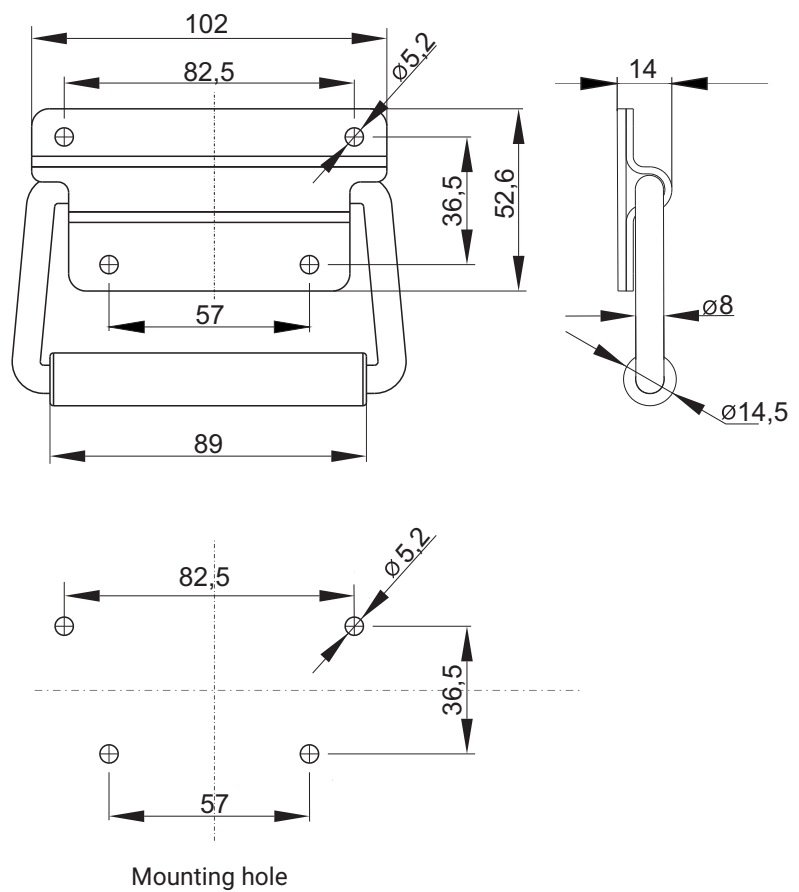

CAT. NUMBER	COMPONENTS	MATERIAL
4.444.004	Holder, Base, Spring	Steel zinc plated

Metal handle 4.442

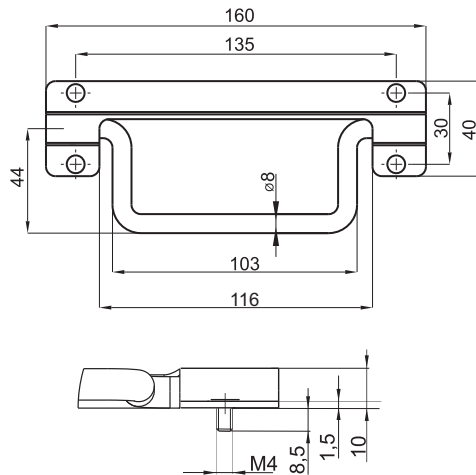

CAT. NUMBER	COMPONENTS	MATERIAL
4.442.001	Holder, Base	Stainless steel
4.442.003	Holder, Base	Steel zinc plated

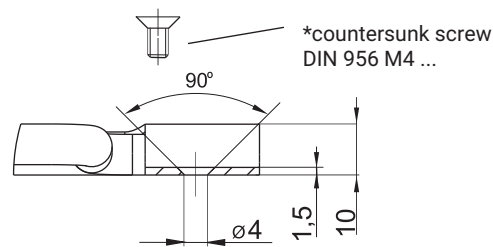

* - not included in the handle

CAT. NUMBER	COMPONENTS	MATERIAL
4.442.002	Holder, Base	Stainless steel
4.442.004	Holder, Base	Steel zinc plated

Drawer handle 4.443

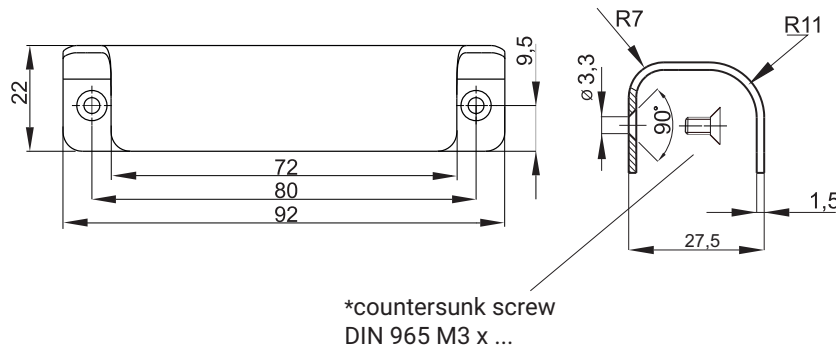

* - not included in the handle

CAT. NUMBER	COMPONENTS	MATERIAL	FINISH [C]	
			RAL 9005	RAL 7035
4.443.001	Holder	Steel zinc plated	04	05
4.443.002	Holder	Stainless steel	-	-

How to order:

Catalogue number
Finish

4.443.001 — C



Mounting holes

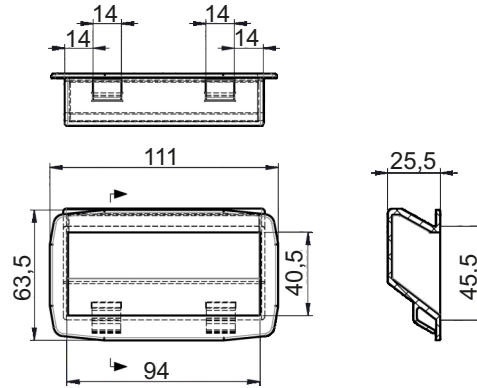
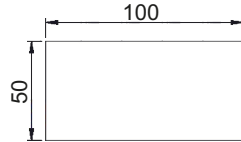

Thickness of metal sheet Ts

CAT. NUMBER	Ts	MATERIAL	FINISH [C]
			RAL 9005
4.102.001	1,2 - 1,6	Polyamide PA6	07
4.102.003	0,8 - 1,2	Polyamide PA6	07

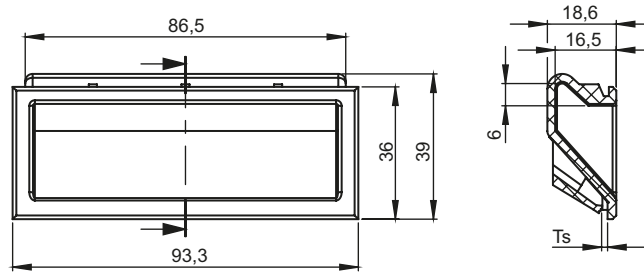

Mounting holes

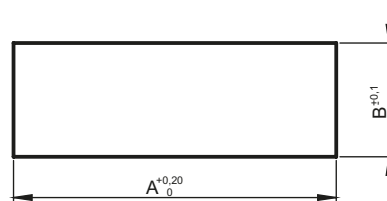

Ts	A	B
1,2 - 1,6	87	30,7
1,75 - 2,2	87	31,5

Ts - Thickness of metal sheet

CAT. NUMBER	MATERIAL	FINISH [C]
		RAL 9005
4.102.002	ABS	07



Mounting holes

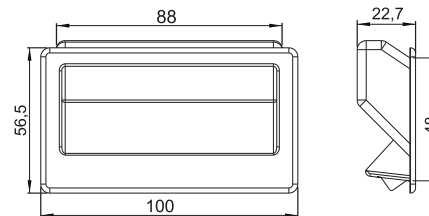
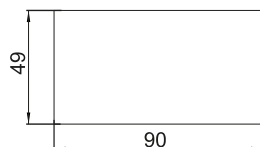

Thickness of metal sheet Ts= 1,0 - 2,5mm

CAT. NUMBER	MATERIAL	FINISH [C]
		RAL 9005
4.470.001	Polyamide PA6	07

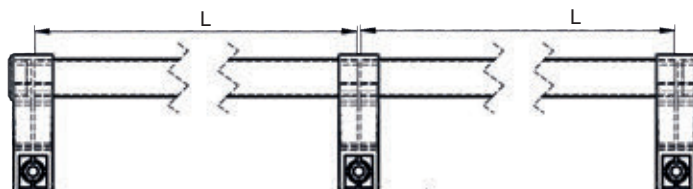
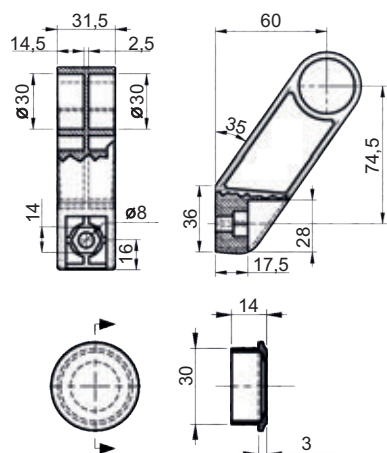

CAT. NUMBER	COMPONENTS	MATERIAL	FINISH [C]	
			RAL 9005	
4.103	Handle	Polyamide PA6	07	
	Bar	Aluminum	-	
HOLDER 4.103	L=200	L=300	L=400	L=500
PA	4.103.01	4.103.02	4.103.03	4.103.04
Aluminum	4.103.05	4.103.06	4.103.07	4.103.08

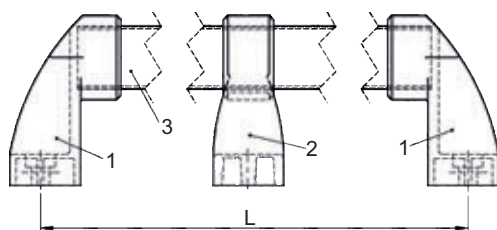

CAT. NUMBER	COMPONENTS	MATERIAL
4.104	Handle	Aluminium
HOLDER 4.104	L=200	L=300
	4.104.001.01	4.104.001.02
		L=400
		4.104.001.03
		L=500
		4.104.001.04

4.104.001

4.104.002

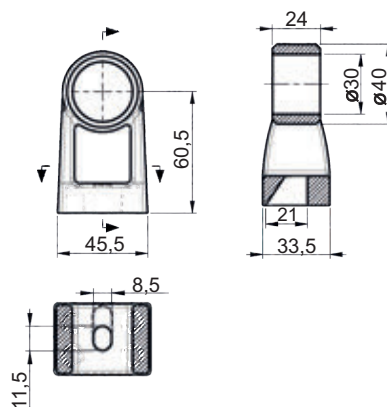
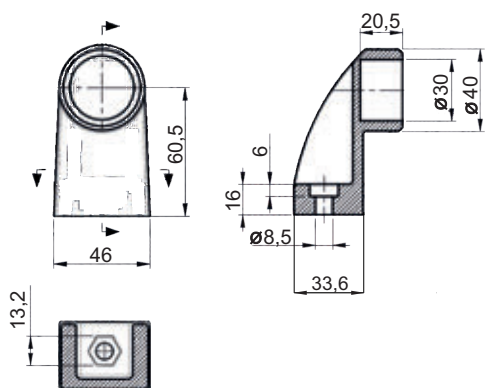

CAT. NUMBER	COMPONENTS	MATERIAL	FINISH [C]	
			RAL 9005	
4.104.001	Outside portion	Polyamide PA6	07	
4.104.002	Middle portion	Polyamide PA6		

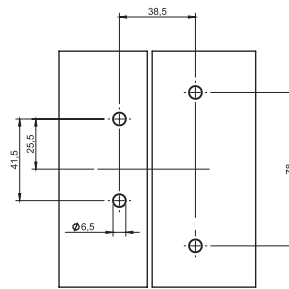
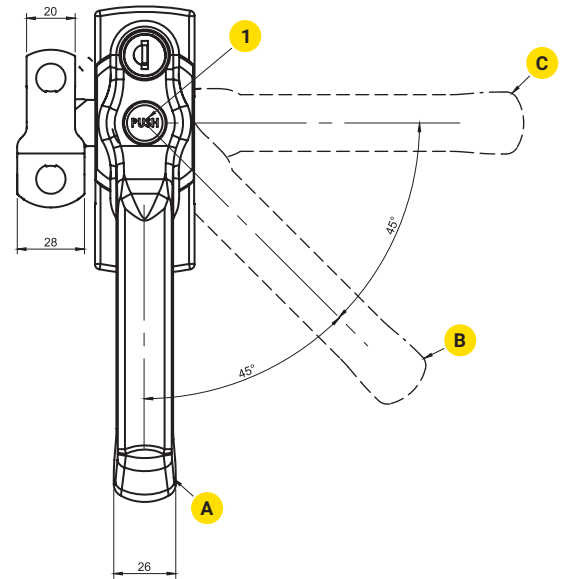
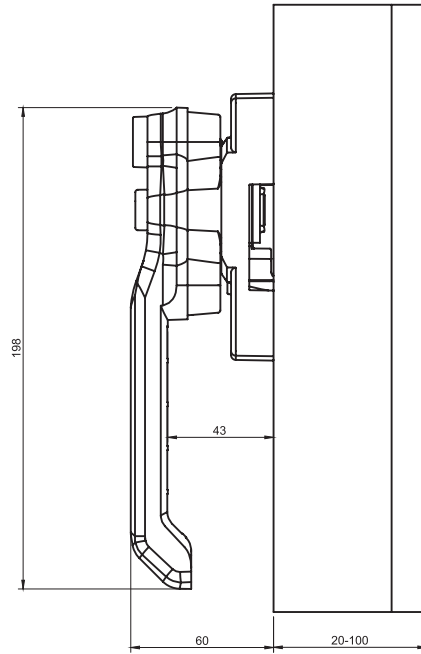

Spacing of holes

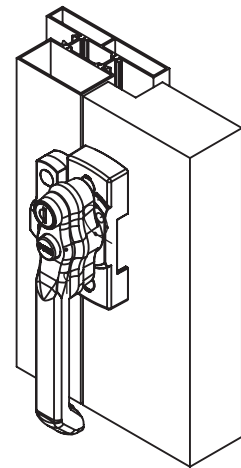

- A** Locked position
- B** Decompression - lock is closed, but pressure is removed
- C** Open position - press button 1 to open

Specification::

1. Locks 4.110.001 and 4.110.002 with a leakage function - protection of the cabinet user against uncontrolled opening of the door due to overpressure in the climate control panel. It allows for pressure compensation before opening the door. Locks 4.110.003 and 4.110.004 (without a button) do not have a leakage function before opening the lock..
2. Resistance of the lock to pressure of 5000 N/mm².
3. The lock can be mounted on doors with a thickness of 20-100 mm.

CATALOGUE NO.	VERSION		COMPONENTS	MATERIALS
4.110.001	lockable*	with push button	Handle	PA6GF30
4.110.002	not lockable	with push button	Base	ZAMAK
4.110.003	lockable*	without push button	Catch	ZAMAK
4.110.004	not lockable	without push button	Cam	Steel

* - possibility to use different key codes

| Accessories

www.roztocze.eu

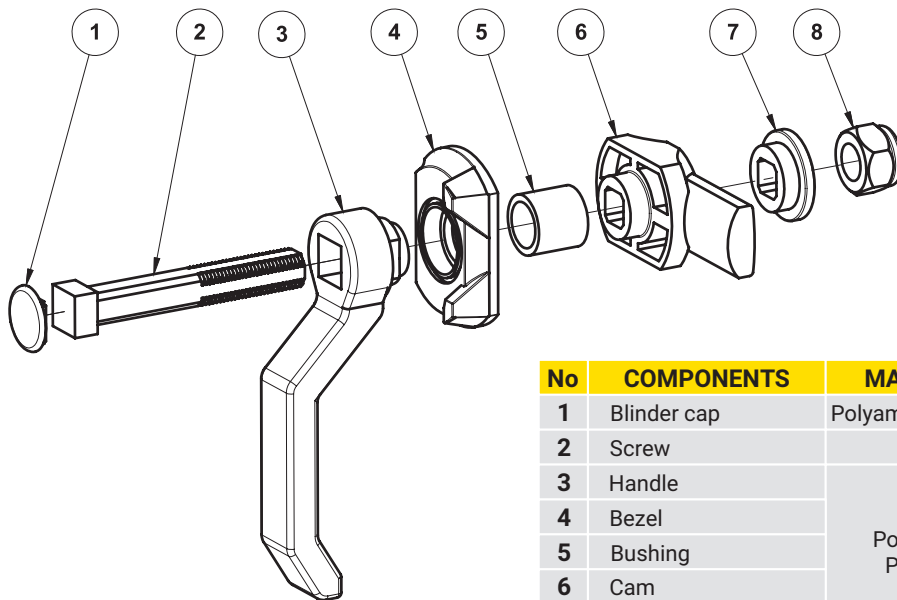
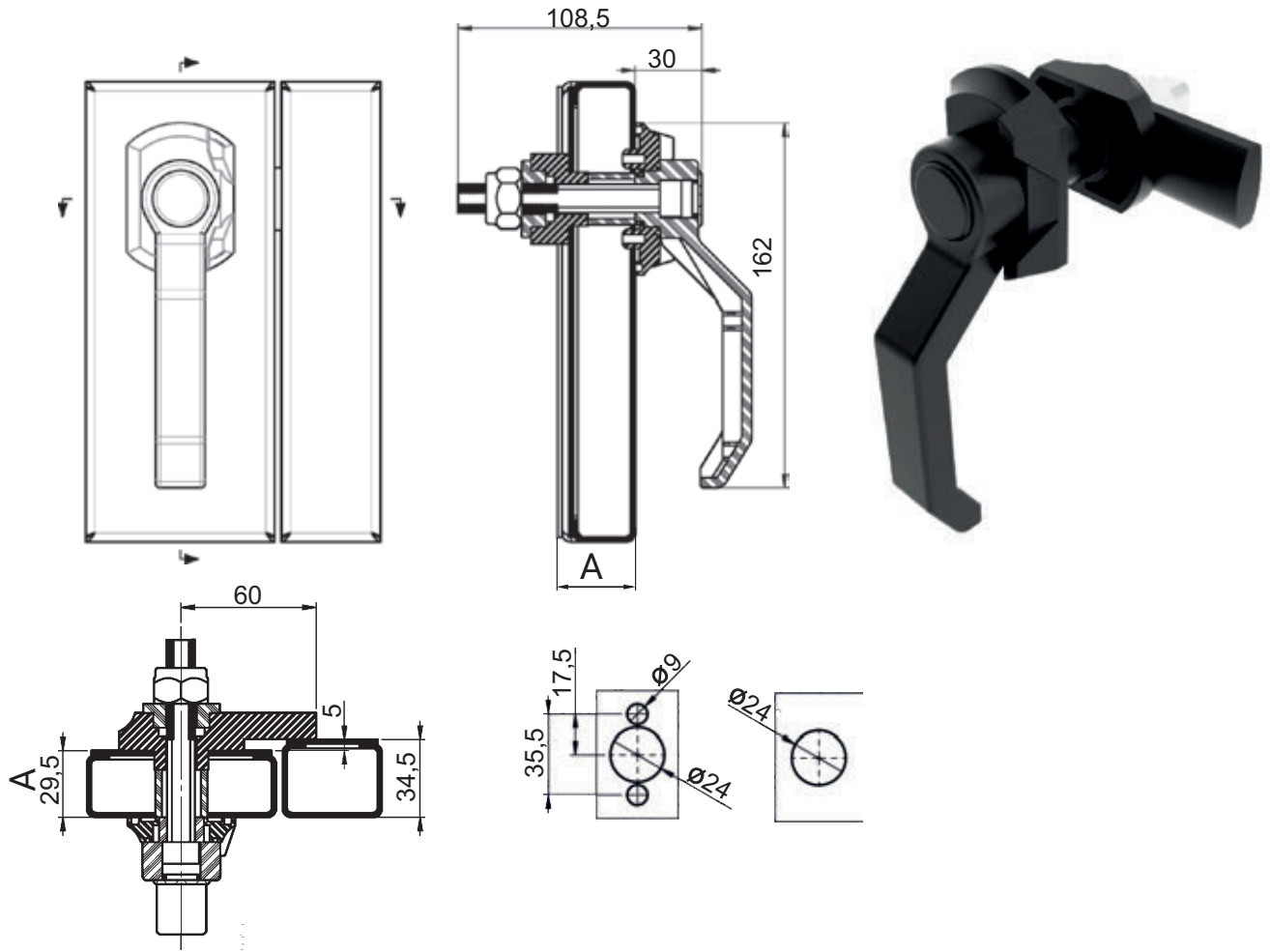

No	COMPONENTS	MATERIAL
1	Blinder cap	Polyamide P6GF30
2	Screw	ZnAl
3	Handle	Polyamide P6GF30
4	Bezel	
5	Bushing	
6	Cam	
7	Washer	Steel zinc plated
8	Nut	

A Thickness door	180° Sign	90° turn Right	90° turn Left	FINISH [C]
				RAL 9005
30 mm	4.105.001	4.105.004	4.105.007	07
50 mm	4.105.002	4.105.005	4.105.008	
70 mm	4.105.003	4.105.006	4.105.009	

Left and right version on request. Delivery time 4-6 weeks.

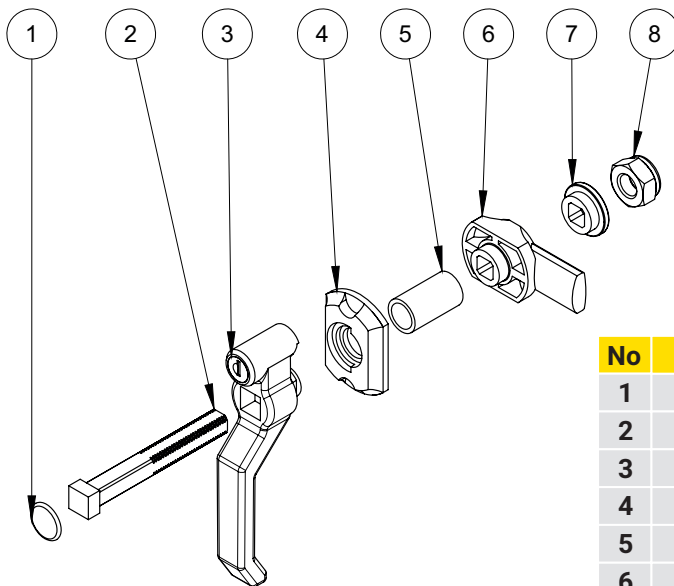
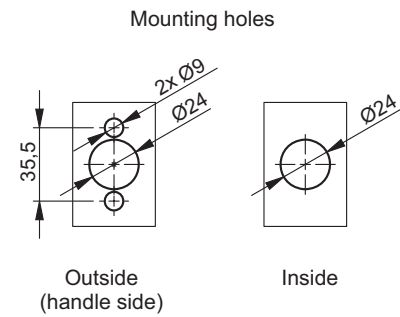
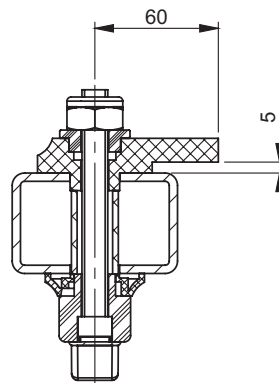
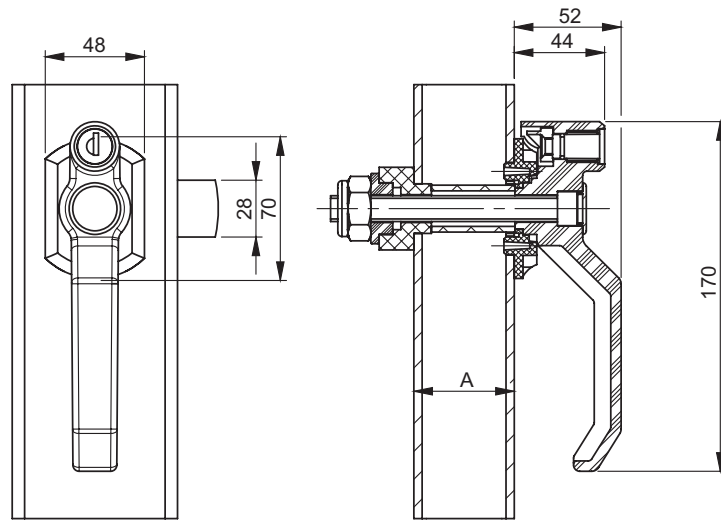

No	COMPONENTS	MATERIAL
1	Blinder cap	Polyamide P6GF30
2	Screw	ZnAl
3	Handle	Polyamide P6GF30
4	Bezel	
5	Bushing	
6	Cam	
7	Washer	
8	Nut	Steel zinc plated

CATALOGUE NUMBER	MAX. DOOR THICKNESS A [mm]	FINISH [C]
		RAL 9005
4.105.101	30	07
4.105.102	50	
4.105.103	70	

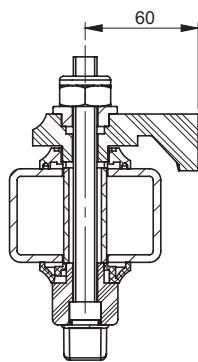
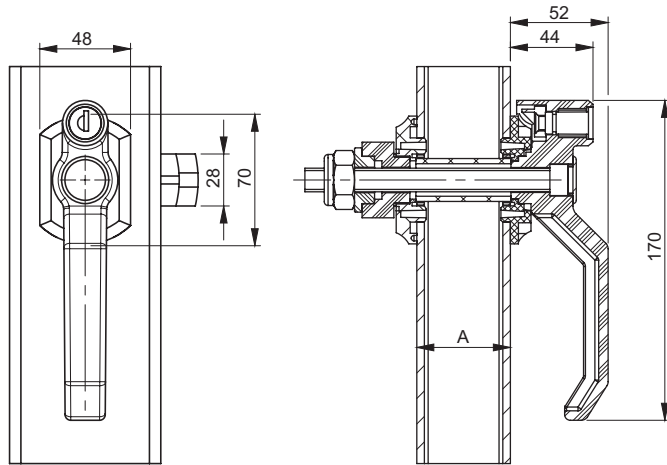

Mounting holes

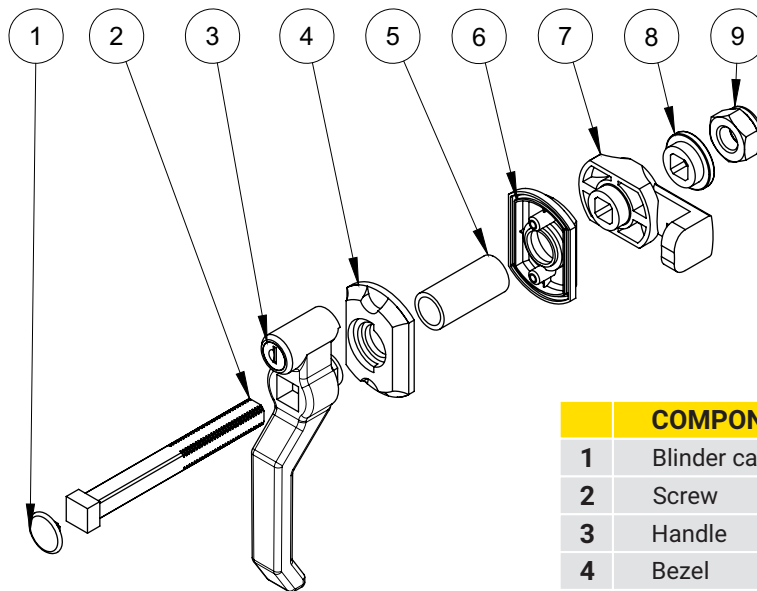
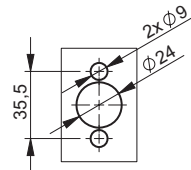

	COMPONENTS	MATERIAL
1	Blinder cap	Polyamide P6GF30
2	Screw	ZnAl
3	Handle	Polyamide P6GF30
4	Bezel	
5	Bushing	
6	Cam	
7	Washer	Steel zinc plated
8	Nut	

CATALOGUE NUMBER	MAX. DOOR THICKNESS A [mm]	FINISH [C]
		RAL 9005
4.106.101	25	07
4.106.102	40	
4.106.103	50	

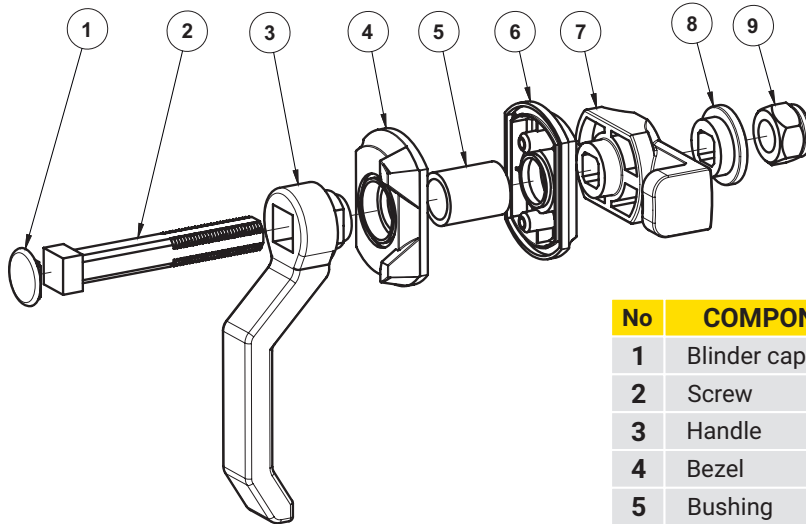
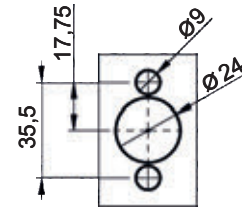
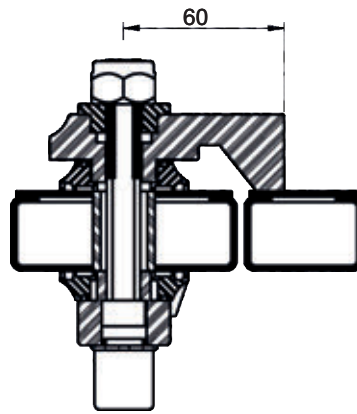
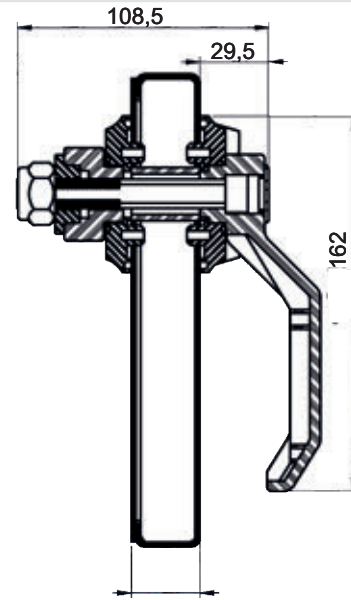
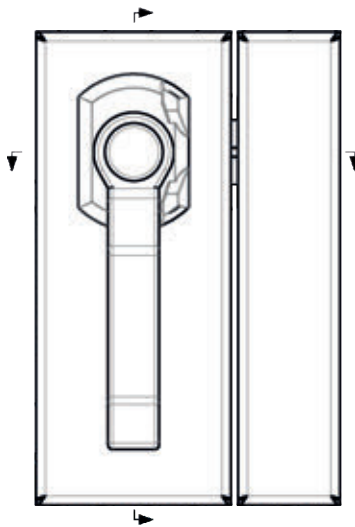

No	COMPONENTS	MATERIAL
1	Blinder cap	Polyamide P6GF30
2	Screw	Steel zinc plated
3	Handle	Polyamide P6GF30
4	Bezel	
5	Bushing	
6	Bezel	
7	Cam	
8	Washer	Steel zinc plated
9	Nut	

A Thickness door	180° Sign	90° turn Right	90° turn Left	FINISH [C]
25 mm	4.106.001	4.106.004	4.106.007	07
40 mm	4.106.002	4.106.005	4.106.008	
50 mm	4.106.003	4.106.006	4.106.009	

Left and right version on request. Delivery time 4-6 weeks.



Latching element

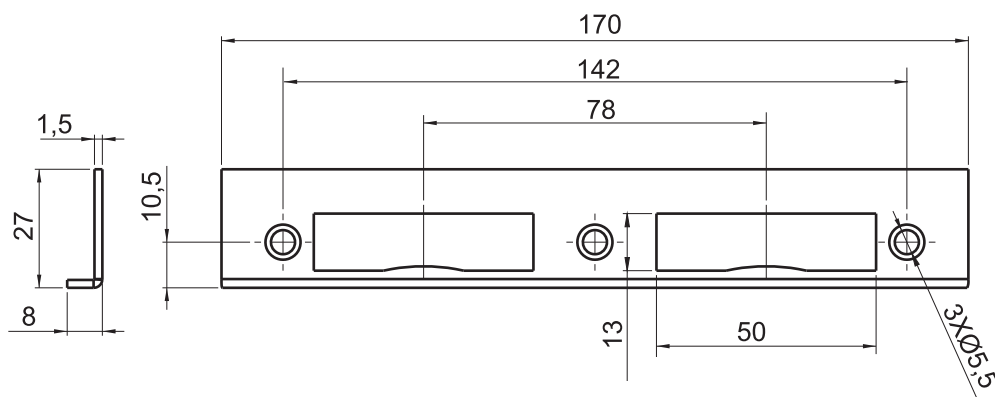

CAT. NUMBER	MATERIAL
4.471.001	Steel zinc plated

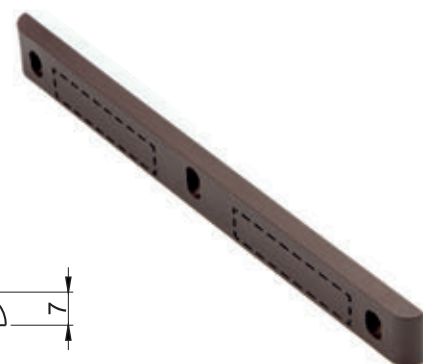

Masking element

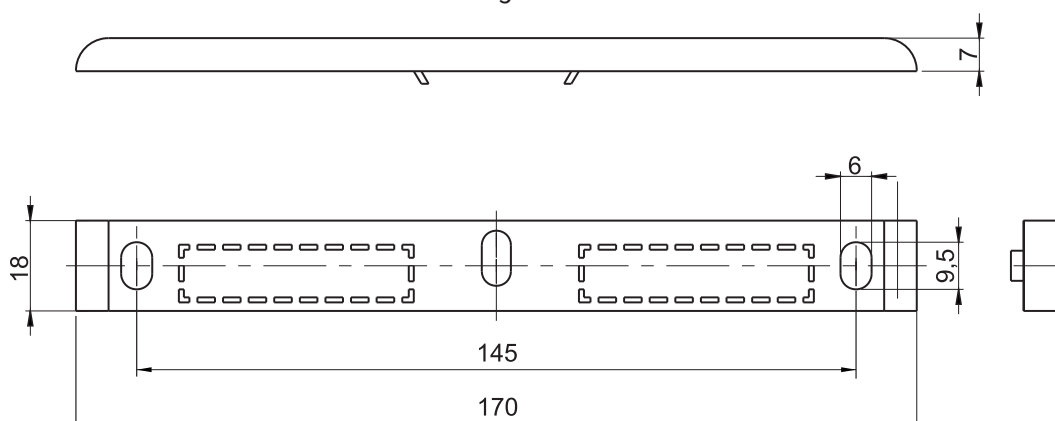

CAT. NUMBER	MATERIAL
4.472.001	Polipropylen - PP color - brown

Fixing pivot 4.427.001, 4.427.002

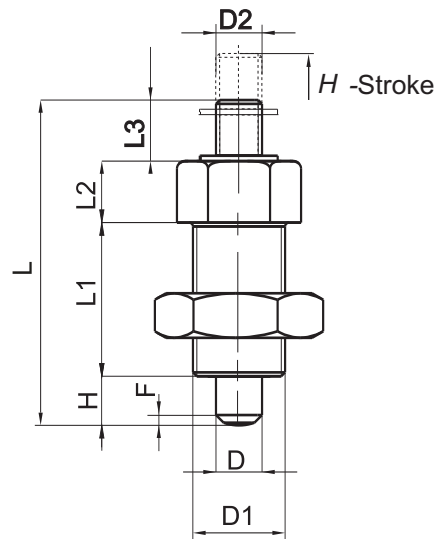

	D1	D2	D	L	L1	L2	L3	H	F
4.427.001	M12 x 1,5	M6	ø6	42	20	8	8	6	1 x 45°
4.427.002	M10 x 1	M4	ø5	37	17	7	7	5,6	0,7 x 45°

CAT. NUMBER	COMPONENTS	MATERIAL
4.427.001	Nut	Steel - oxidized
4.427.002	Housing	
	Pin	
	Cir clip	

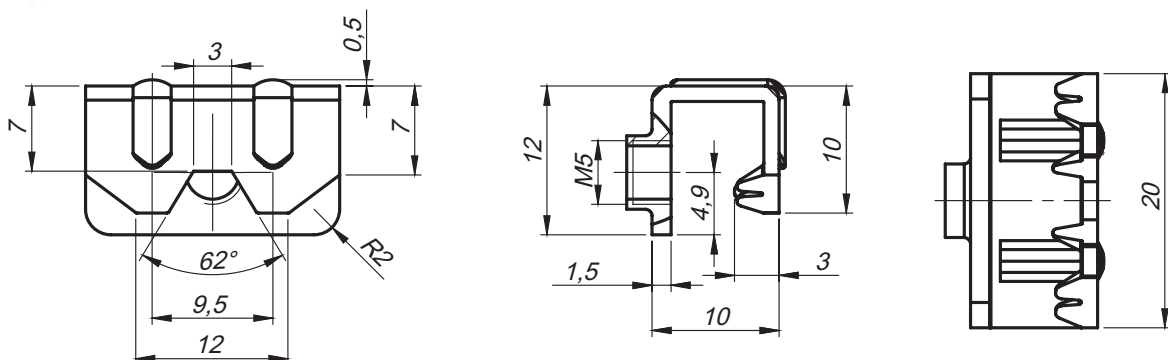

Complete clamp has a screw M5x8

CAT. NUMBER	MATERIAL
4.426.001	Steel zinc plated

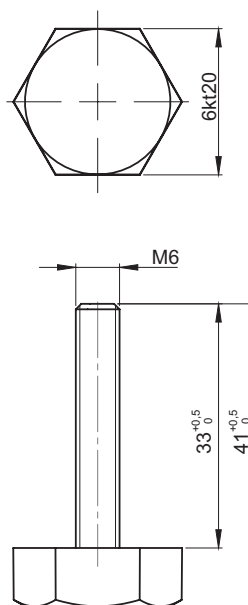

CAT. NUMBER	COMPONENTS	MATERIAL	FINISH [C]
			RAL 9005
4.404.001	Knob	Polyamide PA6	07
	Screw	Steel zinc plated	

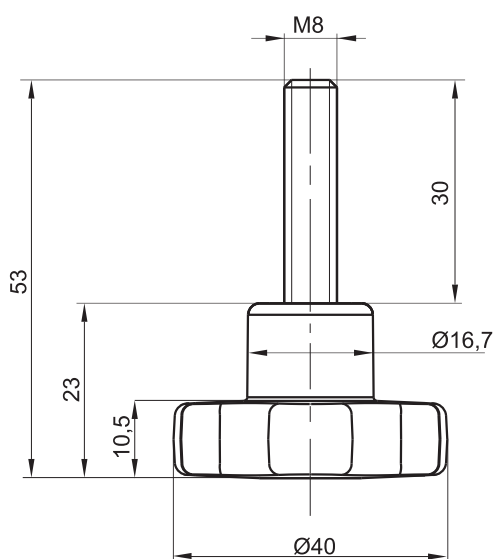



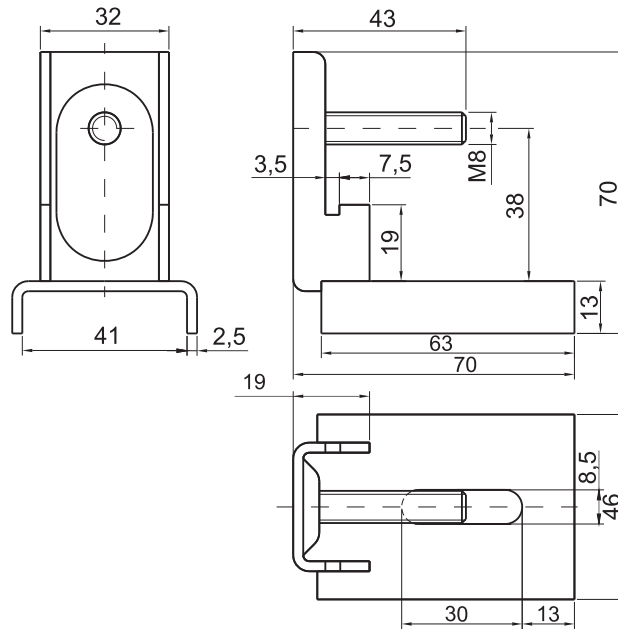



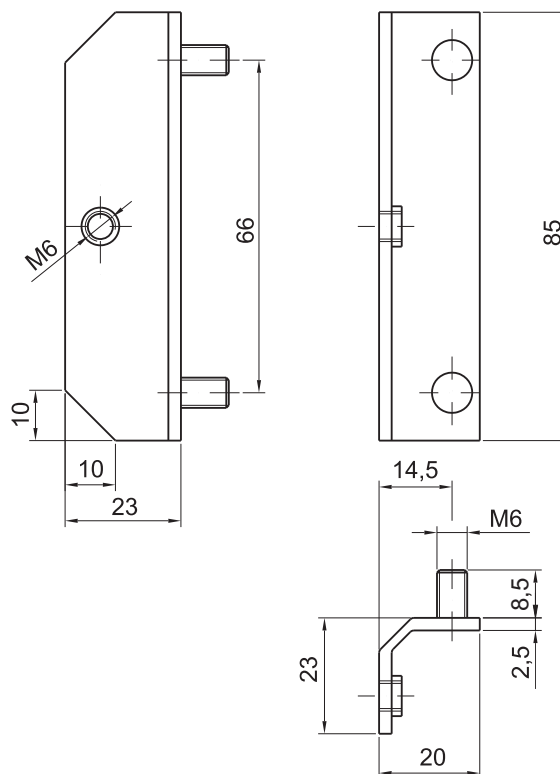

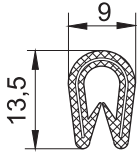

CAT. NUMBER	COMPONENTS	MATERIAL	FINISH [C]
			RAL 9005
4.428.001	Handle	Polyamide PA6 GF30	07
	Screw	Steel - oxidizing	

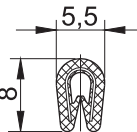

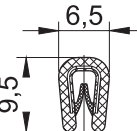
CAT. NUMBER	NAME	MATERIAL
4.412.001	Masking plate bracket	Steel zinc plated

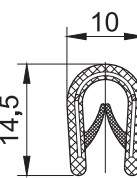

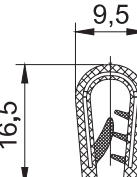
CAT. NUMBER	NAME	MATERIAL
4.413.001	Holder	Steel zinc plated

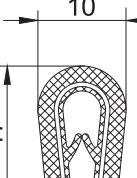
	Design (section of gasket)	Code	Clamping range [mm]	Colour	Material	Sales unit [m]
		UT-4	1,0-4,0	C	PCV	100
		UT-4.2	1,0-1,5	C	PCV	100
		UT-4.3.01	1,0-2,0	C	PCV	100
		UT-4.3.02	1,0-2,0	B	PCV	100
		UT-4.3.06	1,0-2,0	S	PCV	100
		UT-4.4.01	1,0-4,0	C	PCV	100
		UT-4.4.02	1,0-4,0	B	PCV	100
		UT-4.4.04	1,0-4,0	SC	PCV	100
		UT-4.4.05	1,0-4,0	SJ	PCV	100
		UT-4.5.2	1,0-2,5	C	PCV	100
		UT-4.5.4	2,0-4,0	C	PCV	100
		UT-4.5.6	4,0-6,0	C	PCV	100
		UT-4.6	1,0-4,0	C	PCV	100

C - black, B - white, S - gray, SJ - bright gray, SC - dark gray

* Time of delivery 5-6 weeks

	Design (section of gasket)	Code	Clamping range [mm]	Colour	Material	Sales unit [m]
		UT-4.7	2,0-5,0	C	PCV	100
		UT-4.8.2	1,0-2,5	C	PCV	100
		UT-4.8.4	2,0-4,0	C	PCV	100
		UT-4.9.01	1,0-2,0	C	PCV	100
		UT-4.9.02	1,0-2,0	B*	PCV	100
		UT-4.9.03	1,0-2,0	S	PCV	100
		UT-4.10.2	2,0-4,0	C	PCV	100
		UT-3.8	6,0-8,0	C	PCV	100
		UT-3.10	8,0-10,0	C	PCV	100
		UT-2	1,7-2,3	C	PCV	25

C - black, B - white, S - gray, SJ - bright gray, SC - dark gray

* Time of delivery 5-6 weeks

	Design (section of gasket)	Code	Clamping range [mm]	Colour	Material	Sales unit [m]
		UT-5	2,0	C	EPDM	100
		UT-5.1	3,0	C	EPDM	100
		UT-5.2	1,5	C	EPDM	100
		UT-5.3	5,0	C	EPDM	100
		UT-5.4	4,0	C	EPDM	100
		UT-5.5	5,0	C	EPDM	100
		UT-5.6	6,5	C	EPDM	100
		UT-5.7	3,0	C	EPDM	100

C - black, B - white, S - gray, SJ - bright gray, SC - dark gray

* Time of delivery 5-6 weeks

	Design (section of gasket)	Code	Clamping range [mm]	Colour	Material	Sales unit [m]
		UT-30.1	1,0-2,5	C	EPDM	50
		UT-30.4	2,0-4,0	C	EPDM	50
		UT-30.2	1,0-3,0	C	EPDM	50
		UT-35	1,0-2,5	C	EPDM	50
		UT-35.1	1,0-3,0	C	EPDM	50

C - black, B - white, S - gray, SJ - bright gray, SC - dark gray

* Time of delivery 5-6 weeks

- EPDM

- PVC

	Design (section of gasket)	Code	Clamping range [mm]	Colour	Material	Sales unit [m]
		UT-31	1,0-4,0	C	EPDM PCV	50
		UT-31.2	1,0-4,0	C	EPDM PCV	50
		UT-33.2	1,0-2,0	C	EPDM	50
		UT-33.3	1,0-2,5	C	EPDM	100

C - black, B - white, S - gray, SJ - bright gray, SC - dark gray









* Time of delivery 5-6 weeks

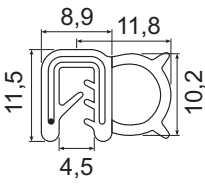

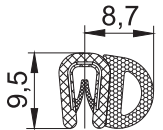
- EPDM

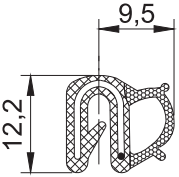

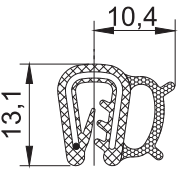
- PVC

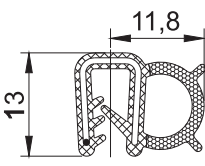
	Design (section of gasket)	Code	Clamping range [mm]	Colour	Material	Sales unit [m]
		UT-33.4	1,0-2,5	C	EPDM	100
		UT-34	1,0-2,0	C	EPDM PCV	100
		UT-37	0,8-2,5	C	EPDM	50
		UT-37.1	2,0	C	EPDM	50
		UT-57A	2,0	C	EPDM	50

C - black, B - white, S - gray, SJ - bright gray, SC - dark gray
 * Time of delivery 5-6 weeks

 - EPDM  - PVC

	Design (section of gasket)	Code	Clamping range [mm]	Colour	Material	Sales unit [m]
		UT-8	1,0-4,0	C	EPDM	25
		UT-8.2	1,5-3,0	C	EPDM	25
		UT-8.3	1,0-4,0	C	EPDM PCV	50
		UT-8.4	1,5-3,0	C	EPDM	50
		UT-8.5	2,0-5,0	C	EPDM PCV	50

C - black, B - white, S - gray, SJ - bright gray, SC - dark gray

* Time of delivery 5-6 weeks

 - EPDM

 - PVC

	Design (section of gasket)	Code	Clamping range [mm]	Colour	Material	Sales unit [m]
		UT-8.6.4	2,0-4,0	C	EPDM	25
		UT-8.6.6	4,0-6,0	C	EPDM	25
		UT-8.7	1,0-3,5	C	EPDM	25
		UT-8.8	3,5-5,0	C	EPDM	3000
		UT-9.2	1,0-2,5	C	EPDM PCV	50
		UT-9.4	2,5-4,0	C	EPDM PCV	50
		UT-9.6	4,0-6,0	C	EPDM PCV	50
		UT-10.3	6,0	C	EPDM PCV	100

C - black, B - white, S - gray, SJ - bright gray, SC - dark gray
 * Time of delivery 5-6 weeks

- EPDM - PVC

	Design (section of gasket)	Code	Clamping range [mm]	Colour	Material	Sales unit [m]
		UT-70	1,0-4,0	C	EPDM	50
		UTB-1	-	C	EPDM	100
		UTB-2	1,5	C	EPDM	5000
		UTB-9	5,0-6,0	C	EPDM	100

C - black, B - white, S - gray, SJ - bright gray, SC - dark gray









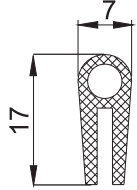

* Time of delivery 5-6 weeks

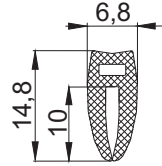

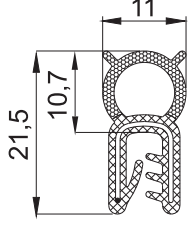
- EPDM

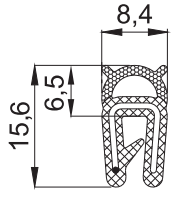

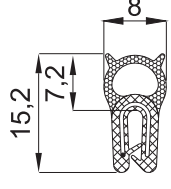
- PVC

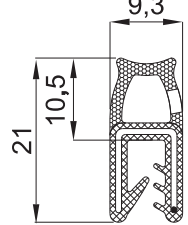





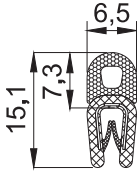

	Design (section of gasket)	Code	Clamping range [mm]	Colour	Material	Sales unit [m]
		UT-26A	2,0-3,0	C	EPDM	100
		UT-27	1,8	C	EPDM	50
		UT-32	1,0-3,0	C	EPDM	50
		UT-38	1,0-2,0	C	EPDM	50
		UT-42	0,5-1,5	C	EPDM	50
		UT-51	1,0-3,0	C	EPDM	50

C - black, B - white, S - gray, SJ - bright gray, SC - dark gray

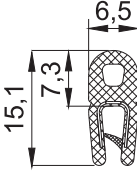
* Time of delivery 5-6 weeks

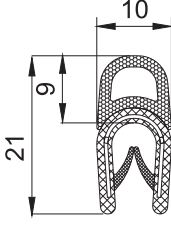
 - EPDM

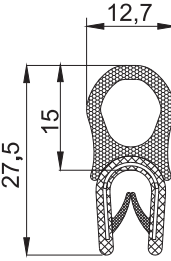
 - PVC

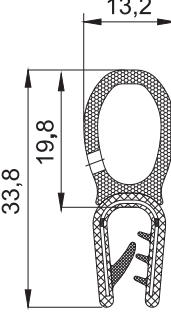
	Design (section of gasket)	Code	Clamping range [mm]	Colour	Material	Sales unit [m]
		UT-43	1,0-2,0	C	EPDM PCV	100
		UT-43B	1,0-2,0	C	EPDM	102
		UT-43.3	1,0-4,0	C	EPDM PCV	50
		UT-43.4	1,0-4,0	C	EPDM PCV	50
		UT-43.5.2	1,0-2,5	C	EPDM PCV	50
		UT-43.5.4	2,0-4,0	C	EPDM PCV	50
		UT-43.5.6	4,0-6,0	C	EPDM PCV	50

C - black, B - white, S - gray, SJ - bright gray, SC - dark gray

* Time of delivery 5-6 weeks

 - EPDM

 - PVC







	Design (section of gasket)	Code	Clamping range [mm]	Colour	Material	Sales unit [m]
		UT-7	-	C	PCV	7x20m
		UT-7.1	-	C	PCV	7x20m
		UT-7.2	-	C	PCV	7x20m
		UT-7.3	-	C	PCV	5x20m
		UT-7.4	-	C	EPDM	100
		UT-7.5	-	C	EPDM	1500

C - black, B - white, S - gray, SJ - bright gray, SC - dark gray

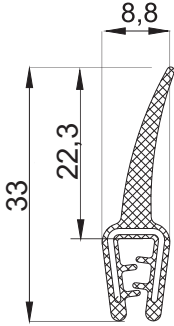
* Time of delivery 5-6 weeks

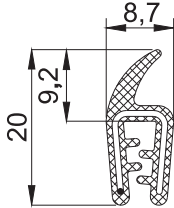
- EPDM

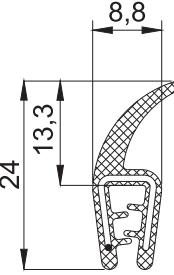
- PVC

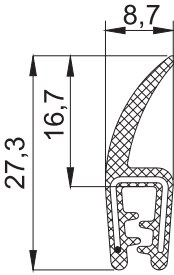
	Design (section of gasket)	Code	Clamping range [mm]	Colour	Material	Sales unit [m]
		UT-80	1,0-3,0	C	EPDM	50
		UT-80.2	1,0-2,0	C	EPDM	100
		UT-80.3	1,0-2,5	C	EPDM	100
		UT-80.4	1,0-3,0	C	EPDM	100

C - black, B - white, S - gray, SJ - bright gray, SC - dark gray

* Time of delivery 5-6 weeks

 - EPDM

 - PVC

	Design (section of gasket)	Code	Clamping range [mm]	Colour	Material	Sales unit [m]	
		USRE-10.04	-	C	EPDM	125	
		USRE-15.03	-	C	EPDM	100	
		USRE-15.04	-	C	EPDM	100	
		USRE-20.04	-	C	EPDM	50	
		USDE-14.12	-	C	EPDM	40	
		UTK-10.11	-	C	EPDM	100	
		UTK-10.12	-	C	EPDM	100	
		USDE-15.15	-	C	EPDM	100	
		No of gasket	A width [mm]	B height [mm]	C	EPDM	
		USPE-05.03	5	3			10
		USPE-08.02	8	2			200
		USPE-08.03	8	3			10
		USPE-10.02	10	2			100
		USPE-10.03	10	3			10
		USPE-10.04	10	4			15
		USPE-10.05	10	5			10/15
		USPE-12.03	12	3			10
		USPE-12.04	12	4			10
		USPE-15.03	15	3			10
		USPE-15.04	15	4			10
		USPE-16.08	16	8			5
		USPE-18.05	18	5			15
		USPE-20.03	20	3			10
USPE-20.05	20	5	10				







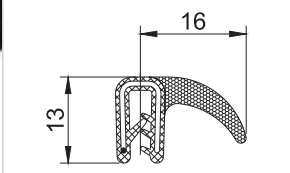

C - black, B - white, S - gray, SJ - bright gray, SC - dark gray

* Time of delivery 5-6 weeks

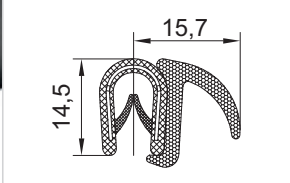
www.roztocze.eu

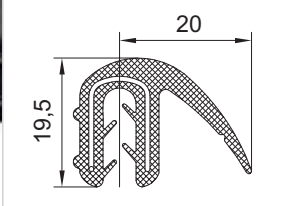
- EPDM - PVC

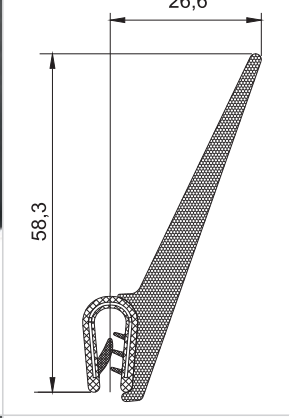
Gasketing profiles |

	Design (section of gasket)	Code	Clamping range [mm]	Colour	Material	Sales unit [m]
		UT-81.1	1,0-2,0	C	EPDM PCV	100
		UT-81.2	1,25-2,0	C	EPDM PCV	100
		UT-81.3	1,0-4,0	C	EPDM	50
		UT-81.4	1,0-3,5	C	EPDM	2500
		UT-81.5	1,0-2,5	C	EPDM	100
		UT-82.2	1,0-2,5	C	EPDM PCV	25
		UT-82.4	2,0-4,0	C	EPDM PCV	25
		UT-82.6	4,0-6,0	C	EPDM PCV	25
		UT-83	1,0-2,5	C	EPDM	3000
		UTP-137	-	C	EPDM	100

C - black, B - white, S - gray, SJ - bright gray, SC - dark gray
* Time of delivery 5-6 weeks



- EPDM



- PVC

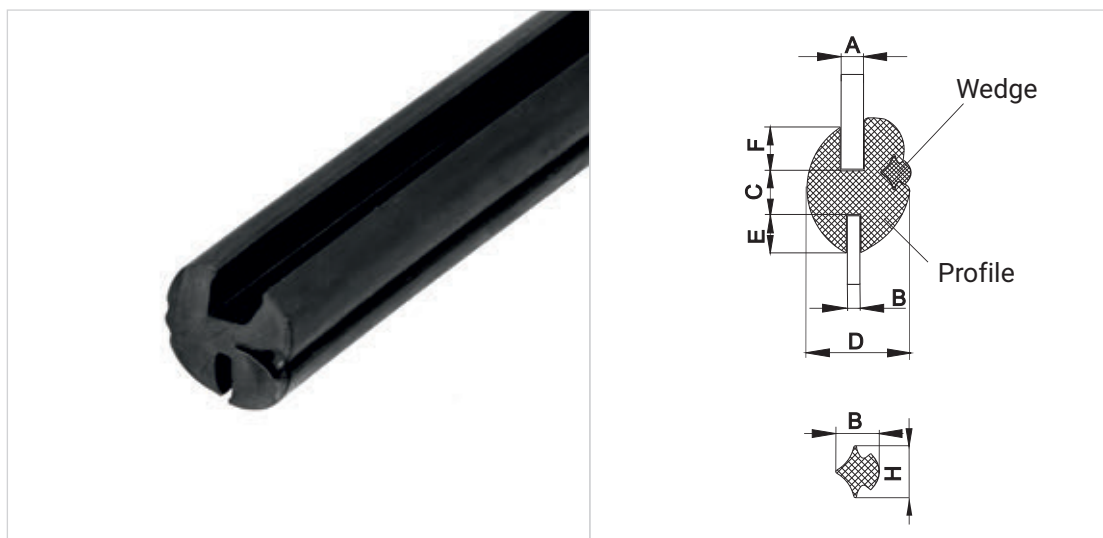









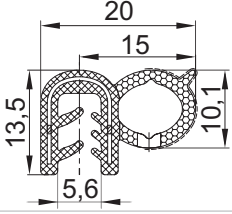

Code	A	B	C	D	E	F	Sales unit [m]	Wedge	Material
US-838	3	1	4	11.6	4.5	6	20	US-328	EPDM
US-838.2	3	2	4	10.2	3	3	50	US-328.1	
US-838.3	4	1.5	4	13.6	5	6	25	US-328	
US-838.4	4	2	7.3	18	11	8.7	15	US-328.2	
US-838.5	4	3	4	12.6	5	6	25	US-328	
US-838.6	4	3	7	16	7	7	20	US-328.2	
US-838.7	4.5	5	7	16	7	7	20	US-328.2	
US-838.8	5	2	5	15	6	6	50	US-328.2	
US-838.9	5	3	7	19	8	8	20	US-328.2	
US-838.10	6	2.5	7	19	8	8	20	US-328.2	

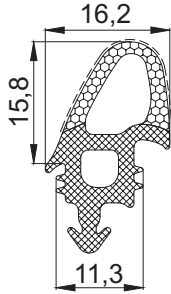
Wedge	H	B	Material	Colour
US-328	7,0	6,0	EPDM	C
US-328.1	5,5	4,5		
US-328.2	9,5	7,5		

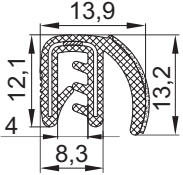

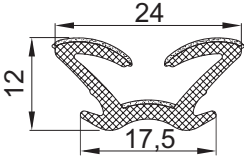

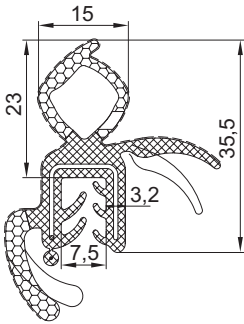

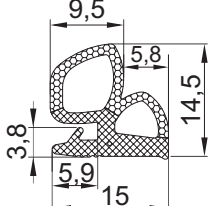

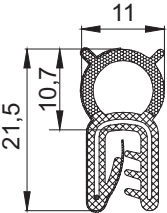

Notice:
 strengthening frame profile should be ordered
 with the wedge
 * wedge fixing tools to order with the manufacturer

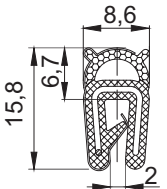

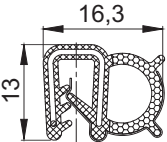
C - black, B - white, S - gray, SJ - bright gray, SC - dark gray
 * Time of delivery 5-6 weeks

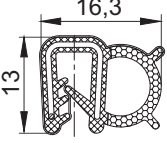
	Design (section of gasket)	Code	Clamping range [mm]	Colour	Material	Sales unit [m]
		UTG-1	3,0-4,5	C	EPDM	100
		UTG-2	-	C	EPDM	100
		UTF-1	1,0-2,5	C	EPDM	100
		UTF-2	-	C	EPDM	100
		UTGF-1	2,5-5,0	C	EPDM	100
		UTGF-2	-	C	EPDM	100

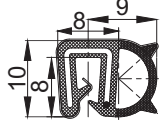
Sealing profiles with shielding electromagnetic interference / RFI signals.

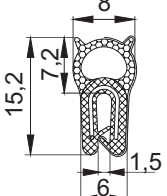
	Design (section of gasket)	Code	Clamping range [mm]	Colour	Material	Sales unit [m]
		UT-32.EMV	1,0-3,0	C	EPDM*	100
		UT-38.EMV	1,0-2,0	C	EPDM*	100
		UT-57A.EMV	2,0	C	EPDM*	100
		UT-57B.EMV	2,0	C	EPDM*	100
		UT-33.3.EMV	1,0-2,5	C	EPDM*	100
		UT-42.EMV	0,5-1,5	C	EPDM*	100

* Soft-sponge rubber with conductive overall coating and steel spring core.

C - black, B - white, S - gray, SJ - bright gray, SC - dark gray

* Time of delivery 5-6 weeks

www.roztocze.eu

Gasketing profiles |

Sealing profiles from UR group meets railway norm **EN 45545-2**

solid rubber (50,60,70 Shore A), classification R22/R23 HL3
sponge rubber (density 0,8 g / cm³), classification R22/R23 HL2

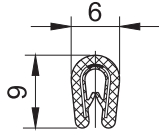
	Design (section of gasket)	Code	Clamping range [mm]	Colour	Material	Sales unit [m]
		UR-4.9.01	1,0-2,0	C	EPDM	100
		UR-4.4.01	1,0-4,0	C	Hexflame 45-1000	100
		UR-8.2	1,5-3,0	C	EPDM	100
		UR-8.8	1,0-3,0	C	PCV	100

C - black, B - white, S - gray, SJ - bright gray, SC - dark gray

* Time of delivery 5-6 weeks

Sealing profiles from UR group meets railway norm EN 45545-2

solid rubber (50,60,70 Shore A), classification R22/R23 HL3
 sponge rubber (density 0,8 g / cm³), classification R22/R23 HL2







	Design (section of gasket)	Code	Clamping range [mm]	Colour	Material	Sales unit [m]
		UR-8.9	2,0-3,5	C	PCV	100
		UR-8.10	1,0-4,0	C	PCV	100
		UR-8.11	1,0-4,0	C	PCV	100
		UR-8.12	3,0-4,5	C	PCV	on request

C - black, B - white, S - gray, SJ - bright gray, SC - dark gray

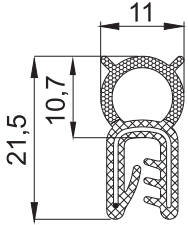
* Time of delivery 5-6 weeks

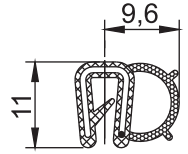
Sealing profiles from UR group meets railway norm **EN 45545-2**

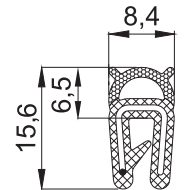
solid rubber (50,60,70 Shore A), classification R22/R23 HL3
sponge rubber (density 0,8 g / cm³), classification R22/R23 HL2

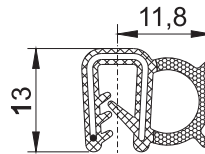
	Design (section of gasket)	Code	Clamping range [mm]	Colour	Material	Sales unit [m]
		UR-32	1,0-3,0	C	EPDM	100
		UR-33.2	1,0-2,0	C	EPDM	100
		UR-38	1,0-2,0	C	EPDM	100
		UR-57A	2,0	C	EPDM	100

C - black, B - white, S - gray, SJ - bright gray, SC - dark gray

* Time of delivery 5-6 weeks





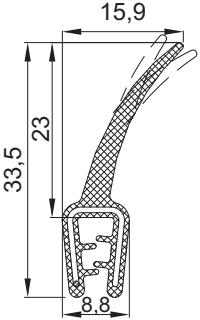

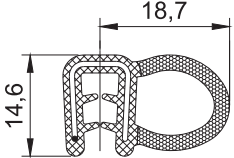

Sealing profiles from UR group meets railway norm EN 45545-2

solid rubber (50,60,70 Shore A), classification R22/R23 HL3
 sponge rubber (density 0,8 g / cm³), classification R22/R23 HL2

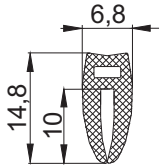
	Design (section of gasket)	Code	Clamping range [mm]	Colour	Material	Sales unit [m]
		UR-43.3	1,0-4,0	C	PCV	on request
		UR-43.5	1,5-3,0	C	PCV	on request
		UR-43.6	2,0-4,0	C	EPDM	100
		UR-80.5	1,0-2,0	C	PCV	on request
		UR-81.3	1,25-2,0	C	PCV	on request

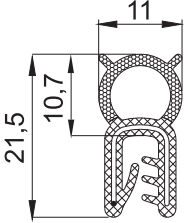
C - black, B - white, S - gray, SJ - bright gray, SC - dark gray
 * Time of delivery 5-6 weeks

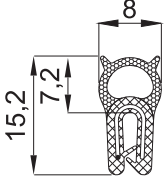
VDI 6022 - standard defining hygienic requirements for air handling units and air-conditioning units

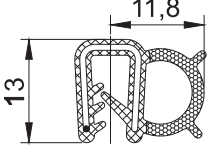
	Design (section of gasket)	Code	Clamping range [mm]	Colour	Material	Sales unit [m]
		UT-8.2.VDI	1,5-3,0	C	EPDM	25
		UT-27.VDI	1,8	C	EPDM	50
		UT-32.VDI	1,0-3,0	C	EPDM	50
		UT-42.VDI	0,5-1,5	C	EPDM	50
		UT-57A.VDI	2,0	C	EPDM	50

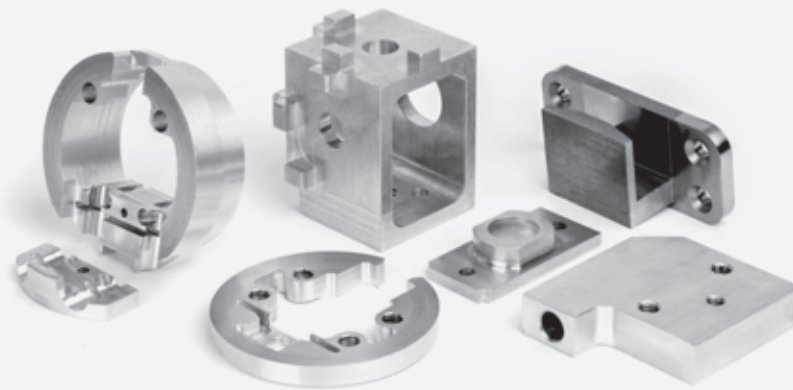

1

Locking systems

2

Locks
Latches

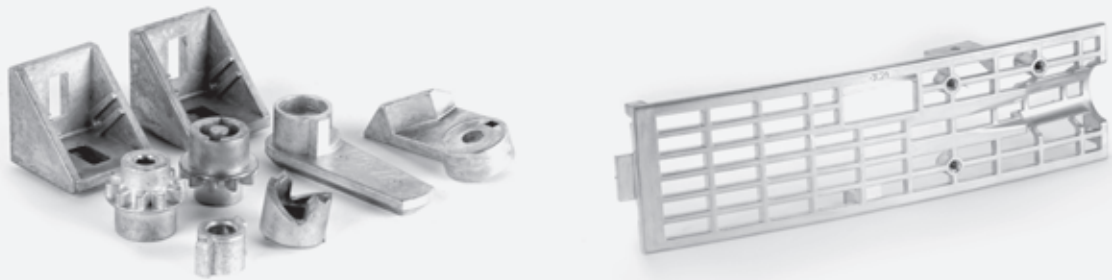

3

Hinges

4

Clamps

5

Accessories



6

Gasketing profiles

7

Custom products





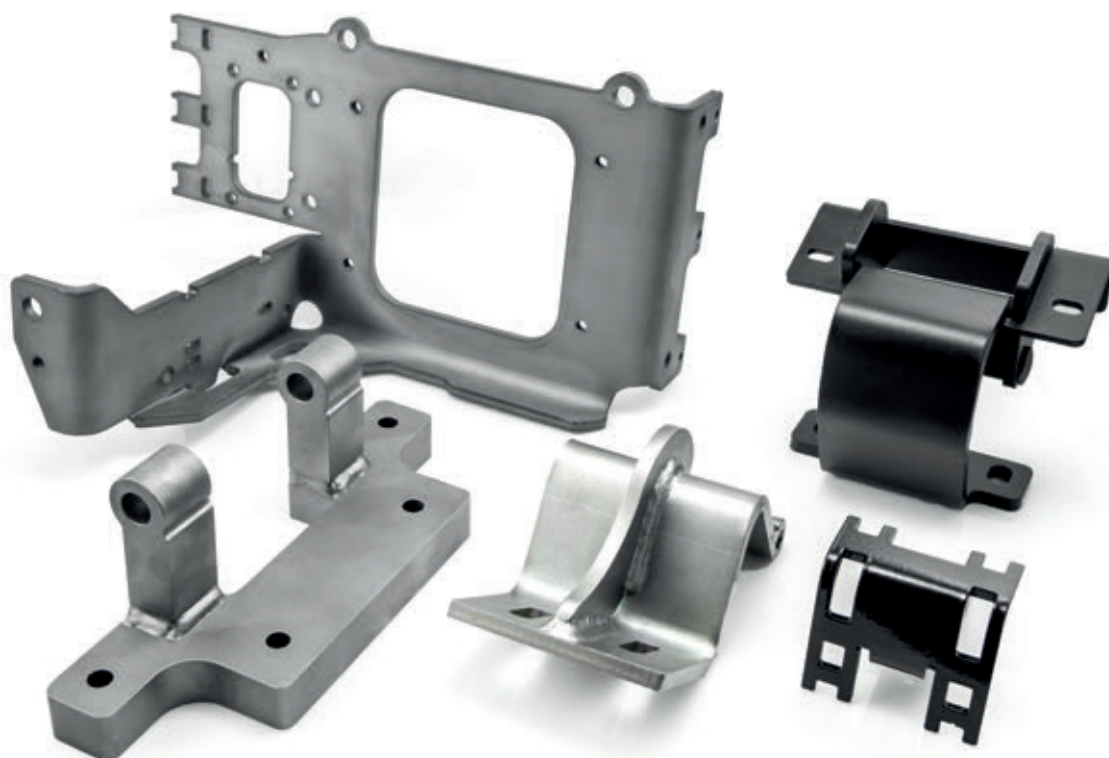





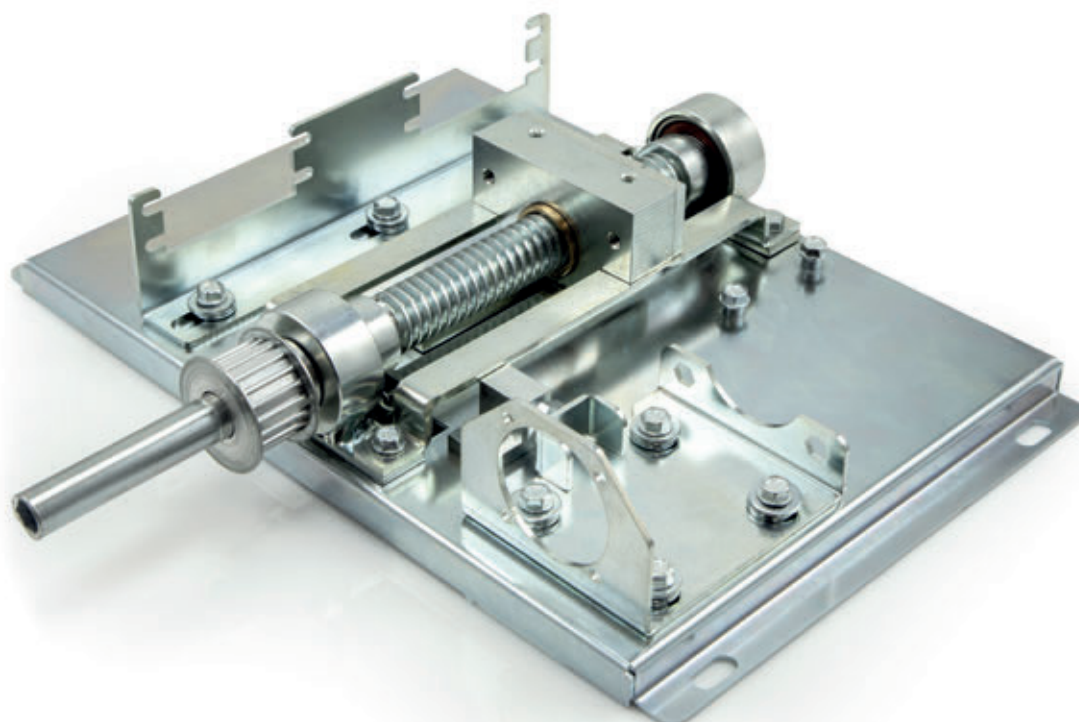
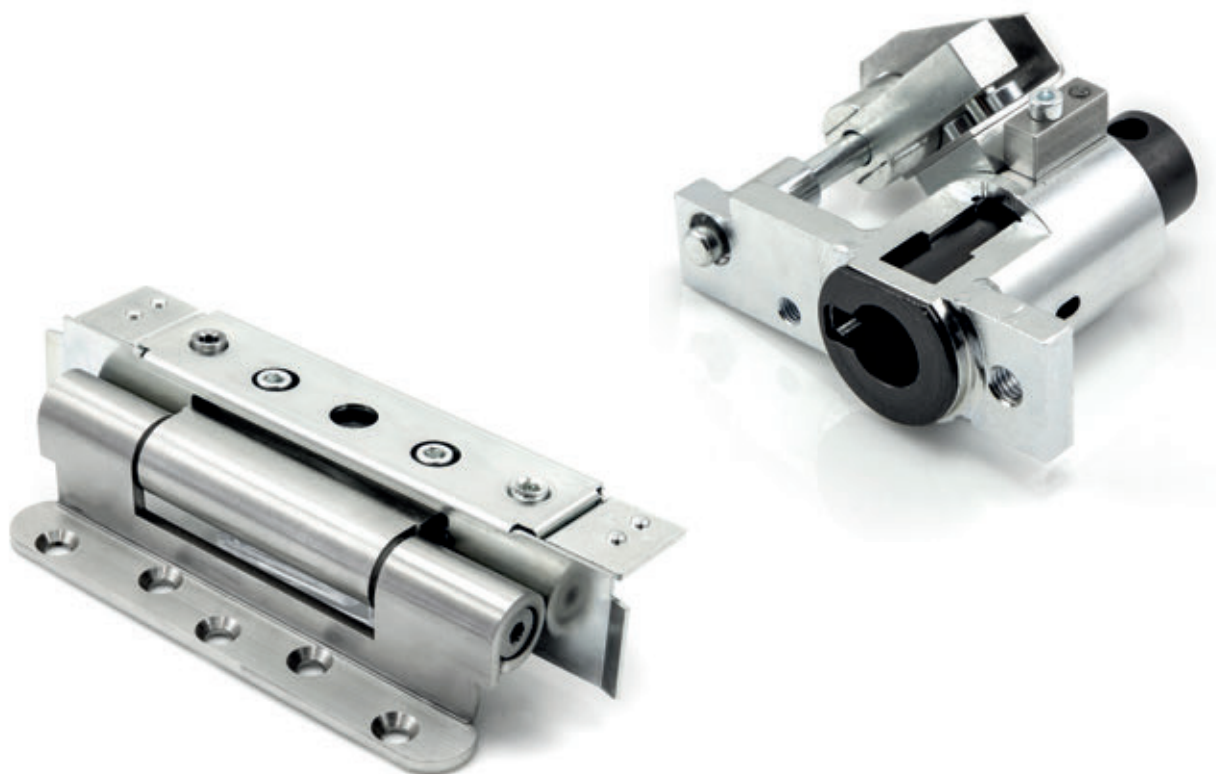

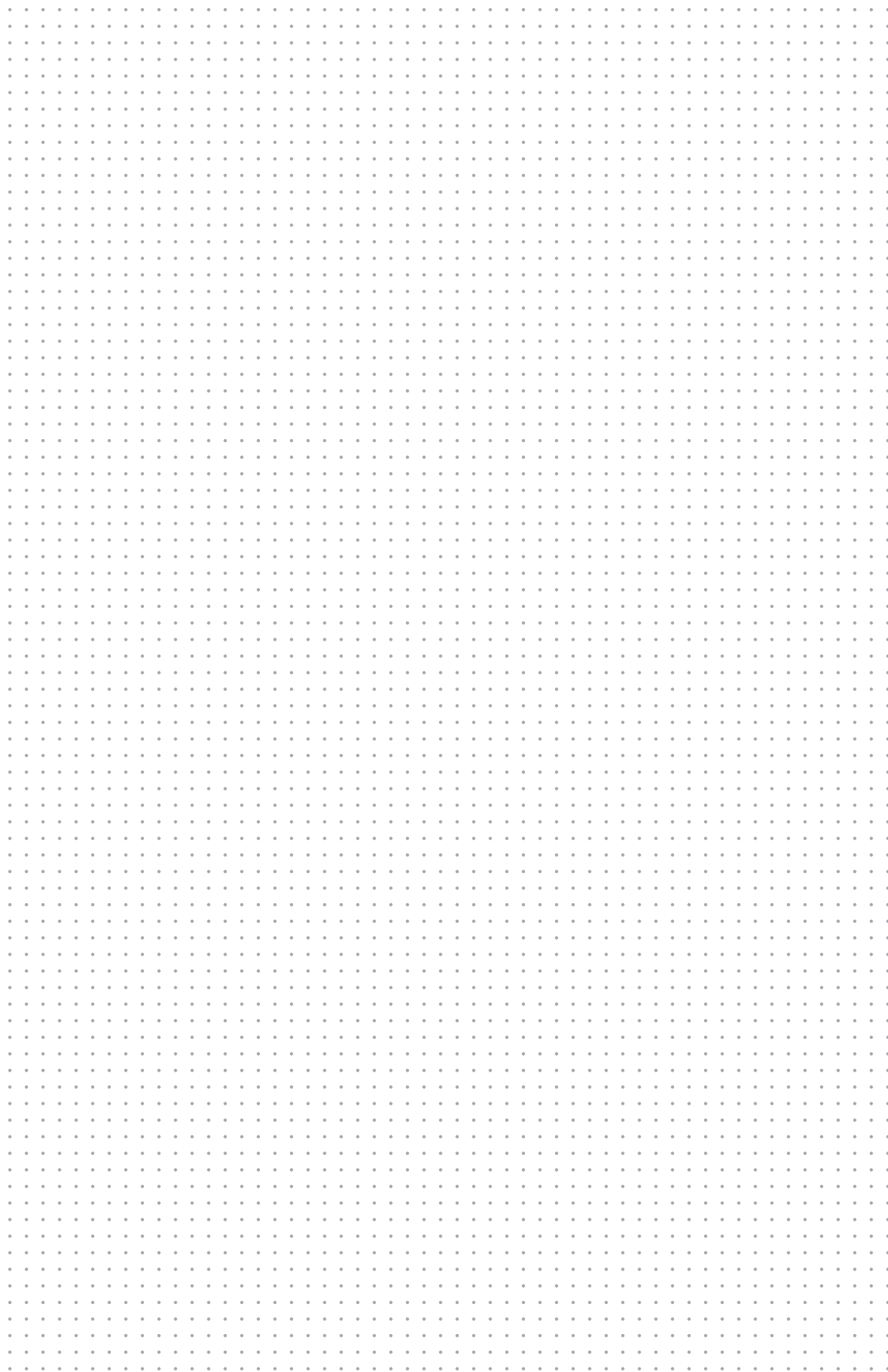





[1A] LOCKING SYSTEMS

Anti-panic lock 1B.ZA.001	1A-13
Anti-panic lock 1B.ZA.002	1A-14
Anti-panic lock 1B.ZA.003	1A-15
Anti-panic lock 1B.ZA.004	1A-16
Anti-panic lock 1B.ZA.005	1A-17
Anti-panic lock 1B.ZA.006	1A-18
Anti-panic lock 1B.ZA.007	1A-19
Anti-panic lock for double wing door	1A-20
Anti-panic lock	1A-12
Cogwheel mechanism distance	1A-9
External fitting with handle for anti-panic locks	1A-21, 22
Locking system (outside the IP) RW250	1A-10
Locking system for aluminium profile door	1A-7
Locking system of lock bolt	1A-8
Locking system outside the IP RW250	1A-11
Locking system with holes 50 x 25	1A-5
Locking system with holes 50 x 25	1A-6
Locking system with space between holes 105/130 internal locks	1A-2
Locking system with space between holes 50/55	1A-3
Locking system with space between holes 50/55	1A-4
Locking systems with space between holes 95/105/130	1A-1
Mounting holes spacing in anti-panic locks	1A-23
Rod strenghtening system	1A-9

[1B] SWINGHANDLE

RS-E Elektronic lock	1B-10
RS100	1B-3
RS100/T	1B-3
RS100/U	1B-3
RS110	1B-4
RS130	1B-8
RS130/U	1B-8
RS135	1B-8
RS135/U	1B-8
RS140	1B-8
RS140/U	1B-8
RS145	1B-8
RS145/U	1B-8
RS150	1B-26
RS151MZ	1B-36
RS151N	1B-34
RS151N	1B-35
RS152MZ	1B-36
RS152N	1B-34
RS152N	1B-35
RS154	1B-25
RS160	1B-29
RS161	1B-30
RS168	1B-32
RS168/B	1B-32
RS169	1B-33
RS170	1B-33
RS173	1B-13
RS174	1B-31
RS175	1B-31
RS200	1B-3
RS200/T	1B-3
RS200/U	1B-3
RS210	1B-4

RS300	1B-23
RS400	1B-5
RS400/U	1B-5
RS400W	1B-5
RS400W/U	1B-5
RS420	1B-5
RS420/U	1B-5
RS420W	1B-5
RS430	1B-6
RS430/U	1B-6
RS500	1B-5
RS500/U	1B-5
RS500W	1B-5
RS500W/U	1B-5
RS510	1B-7
RS 520	1B-5
RS520/U	1B-5
RS520W	1B-5
RS530	1B-6
RS530/U	1B-6
RS600	1B-12
RS610	1B-12
RS650	1B-11
RS700	1B-14
RS710	1B-14
RS715	1B-15
RS716	1B-15
RS717	1B-17
RS720	1B-18
RS730	1B-16
RS750	1B-23
RS750	1B-23
RS761	1B-19
RS761	1B-21
RS762	1B-20
RS762	1B-21
RS763	1B-21
RS763	1B-22
RS790	1B-24
RS800	1B-4
RS900	1B-7
RS950 Swinghandle anti-theft	1B-28
RS980	1B-27

LOCK RW

RW100	1B-37
RW110	1B-37
RW200	1B-38
RW400/N	1B-18
RW400/M	1B-18
RW410/N	1B-18
RW410/M	1B-18
RW500	1B-38
RW510	1B-40
RW520	1B-40

Internal lock for passive door	1B-41
Lever Lock 1B.ZD100	1B-44
Lock ZWA1	1B-42
Lock ZWA1	1B-43
ZW, PANIK - ZWP	1B-1
ZWP002	1B-2

[1C] LOCKING SYSTEMS COMPONENTS

AAadapter 1C.903.....	1C-27
Adapter 1C.916.....	1C-43
Cam adapter JC-20018/36.....	1C-24
Quick Assembly Fastener 1C.921.001.....	1C-26

Cam

1-point cam without limiter.....	1C-12
1-point cam without limiter.....	1C-13
1-point cam without limiter.....	1C-14
1-point cam with limiter.....	1C-10
1-point cam with limiter.....	1C-11
1-point cam.....	1C-20
1-point cam.....	1C-21
1-point cam.....	1C-9
1-point cam JZ.....	1C-23
2-point cam.....	1C-15
3-point cam without limiter.....	1C-19
3-point cam without limiter.....	1C-15
3-point cam with limiter.....	1C-17
3-point cam with limiter.....	1C-18
3-point cam with limiter.....	1C-22
3-point cam.....	1C-16
Cam ZAMAK JZN-10027/30.....	1C-24

Cogwheel mechanism

MZ1.....	1C-28
MZ1.....	1C-29
MZ2.....	1C-30
MZ2.....	1C-31
MZ2.....	1C-32
MZ3.....	1C-33
MZ1-DB.002.....	1B-39
MZ1K-DB.002.....	1B-39
MZ1P-DB.002.....	1B-39
Bushing 1C.901.....	1C-27
Cap 1C.902.....	1C-27
Catch.....	1C-35
Catch.....	1C-36
Catches W314.....	1C-38
Catch W314-70.....	1C-39
Flat rods.....	1C-35
Flat rods.....	1C-36
Flat rods ver. B.....	1C-37
Flat rods ver. C.....	1C-39
Flat rods ver. D.....	1C-40
Flat rod with rollers.....	1C-34
Grip handle 1C.904.....	1C-40
Lock cylinder WRS-B.....	1C-2
Lock cylinder WRS-WCM.....	1C-1
Multipoint locking system with one flat bar.....	1C-41, 42
Rod guide 1C.906.100.....	1C-7
Rod guide 1C.906.....	1C-6
Rod guide P314.....	1C-8
Rod guide Ø6.....	1C-6
Rod guide Ø8.....	1C-6
Rod Ø6.....	1C-4
Rod Ø8.....	1C-4
Rod Ø8.....	1C-5
Self-locking cylinder WRS-P.....	1C-2

Shaped insert WRS-X.....	1C-1
Shaped insert WSR-360-X.....	1C-2
Shape inserts WRS-D13.....	1C-3
Sliding End Cap 1C.920.001.....	1C-25

[2A] LOCKS

Explanation of open fields.....	2A-1
Information card.....	2A-2
Adapter 2.920.....	2A-118
AX.....	2A-117

Blockade

2.901.....	2A-108
2.902.....	2A-107
2.903.....	2A-108
2.904.....	2A-107
2.905.....	2A-107
2.910.....	2A-109

Key

2.KL.009.....	2A-116
2.KLA-X.....	2A-111
2.KLB-X.....	2A-111
2.KL-D13S.008.....	2A-115
2.KLD-T13.....	2A-111
2.KL-X.001.....	2A-112
2.KL-X.002.....	2A-112
2.KL-X.003.....	2A-113
2.KL-X.004.....	2A-113
2.KL-X.005.....	2A-114
2.KL-X.006.....	2A-114
2.KL-X.007.....	2A-115
KLT-WF.....	2A-116
2.KLE-GZ.....	2A-110
K2.KLF-GZ.....	2A-110

Cover 2.904.020SN.....	2A-53
Dust cover 2.904.....	2A-104
Handle for lock 2.905.....	2A-105
Internal handle 1C.DB.002.....	2A-76
Locking flap 2.700.....	2A-102
Overview of lock inserts M22.....	2A-3
T-Handle Dust Cover 2.904.010.....	2A-75
Wing knobs type M.....	2A-10

Lock

2.501.....	2A-99
2.502.....	2A-100
2.503.....	2A-98
2.504.....	2A-95
2.505.....	2A-97
2.506.....	2A-66
2.507.....	2A-101
2.509.....	2A-88
2.510.....	2A-93
2.510.....	2A-94
2.511.....	2A-91
2.512.....	2A-100
2.515.....	2A-90
2.516.....	2A-89
2.520.....	2A-98

2.521	2A-97	M22P	2A-13
2.525	2A-59	M22PM-K	2A-64
2.526	2A-80	M22PW	2A-26
2.527	2A-59	M22R	2A-37
2.528	2A-58	M22SA	2A-46
2.529	2A-31	M22SA2	2A-41
2.530	2A-56	M22SC	2A-45
2.531	2A-79	M22SD20SN	2A-40
2.532	2A-79	M22SD22	2A-55
2.533	2A-83	M22SD30	2A-42
2.540	2A-78	M22SD40	2A-44
2.544	2A-80	M22SE	2A-47
2.601	2A-87	M22SG	2A-48
2.602	2A-4	M22SK30	2A-50
2.603	2A-68	M22SK32	2A-51
2.604	2A-84	M22SK37 Pressure	2A-52
2.605	2A-84	M22SP	2A-39
2.606	2A-82	M22SP2	2A-43
2.607	2A-82	M22TR	2A-33
2.608	2A-81	M22W	2A-24
2.609	2A-81	M22W32	2A-25
2.610	2A-92	M22ZD	2A-22
2.611	2A-31	M22ZW	2A-23
2.612	2A-31	M22ZW22	2A-23
2.613	2A-85	M24	2A-19
2.615	2A-86	M24B	2A-18
2.616	2A-69	M24C	2A-60
2.630	2A-67	M24ZN	2A-19
2.800	2A-77	M28-1	2A-57
JZ-3522 Lock with self-locking cam	2A-62	M28-2	2A-57
2.M19	2A-66	M22-6 Snap lock	2A-63
M16	2A-4	RW300 with knob	2A-72
M16/19	2A-5	TR12	2A-103
M16/45	2A-4	With handle L	2A-73
M16SD22	2A-54	With handle T	2A-74
M19-1	2A-6	Z-0233	2A-30
M19DC	2A-61	Z-2106	2A-30
M19W	2A-29	2.PM	2A-70
M22-1	2A-7	2.PM	2A-71
M22-2	2A-8	2.PMPA	2A-70
M22-3	2A-9	2.PMPA	2A-71
M22-30	2A-20	ZG	2A-117
M22-40	2A-21	ZG	2A-117
M22-5	2A-14	ZZR18	2A-34
M22-60	2A-21	ZZR18.010	2A-35
M22B	2A-17	ZZR19	2A-34
M22BK	2A-65	ZZR28	2A-34
M22D	2A-12	ZZR28/S	2A-36
M22DC	2A-61	ZZR38	2A-34
M22D-M	2A-68	ZZR50	2A-34
M22-DU	2A-11	CZ-E1	2A-37
M22DW	2A-26	GE-0100	2A-38
M22DW22	2A-25	GE-0101	2A-38
M22EW	2A-28	Roller latch 2.200	2A-96
M22FW	2A-28	Roller latch 2.210	2A-96
M22GP4	2A-15		
M22GP5	2A-15		
M22IP	2A-32		
M22JR-SN	2A-49		
M22K	2A-16		
M22KW	2A-16		
M22MS	2A-27		

[2B] LATCHES

3.561	2B-10	3.538	3B-44
3.562	2B-11	3.539	3B-44
3.563	2B-12	3.540	3A-14
3.565	2B-15	3.541	3A-13
3.566	2B-15	3.543	3A-16
3.567	2B-16	3.544	3A-17
3.ST200 Catch	2B-2	3.545	3A-17
3.ST201	2B-1	3.550	3B-42
3.ST202	2B-1	3.ST4	3B-1
3.ST204	2B-2	3.ST4-1	3B-1
3.ST205	2B-2	3.ST5	3B-7
3.ST206	2B-5	3.ST6	3B-7
3.ST207	2B-5	3.ST7	3B-43
3.ST208	2B-8	3.ST7-1	3B-43
3.ST209	2B-6	3.ST7-2	3B-43
3.ST210	2B-8	3.ST8	3B-18
3.ST211	2B-6	3.ST9	3B-18
3.ST261	2B-7	3.ST10	3B-17
3.ST262	2B-7	3.ST11	3B-17
3.ST263.001	2B-9	3.ST12	3B-11
3.ST263.100	2B-9	3.ST12-1	3B-13
3.ST263.101	2B-10	3.ST12-1B	3B-12
3.ST264.002	2B-14	3.ST12-2	3B-11
3.ST264	2B-3	3.ST12B	3B-12
3.ST265	2B-3	3.ST13	3B-5
3.ST265	2B-4	3.ST15	3B-17
3.ST267	2B-14	3.ST16	3B-6
4.490	2B-13	3.ST17	3A-64
4.491	2B-13	3.ST18	3A-64
4.700 Bolt	2B-16	3.ST19-2	3B-14
		3.ST20	3B-29
		3.ST20	3B-31
		3.ST21	3A-65
		3.ST22	3A-65
		3.ST23	3A-33
		3.ST24	3B-30
		3.ST24-34	3B-30
		3.ST26	3B-37
		3.ST26	3B-38
		3.ST27	3B-3
		3.ST27-1	3B-3
		3.ST28	3A-52
		3.ST29	3A-66
		3.ST30	3A-44
		3.ST31	3B-19
		3.ST32	3B-10
		3.ST33	3B-19
		3.ST34	3B-19
		3.ST35	3A-45
		3.ST35-1	3A-45
		3.ST35-2	3A-47
		3.ST37	3A-51
		3.ST38	3B-20
		3.ST39	3B-20
		3.ST40	3B-16
		3.ST41	3B-16
		3.ST42	3A-30
		3.ST4-2	3B-2
		3.ST43	3B-8
		3.ST43	3B-9
		3.ST4-4	3B-2
		3.ST46	3B-27

[3A, 3B] HINGES

3.501	3B-47
3.502	3B-47
3.503	3B-47
3.504	3A-63
3.505	3A-63
3.506	3A-63
3.507	3A-63
3.509	3A-5
3.510	3A-6
3.511	3A-7
3.512	3A-11
3.513	3A-12
3.514	3A-31
3.516	3A-19
3.517	3A-34
3.518	3A-35
3.519	3A-31
3.526	3A-19
3.527	3A-18
3.529	3A-22
3.530	3A-22, 23
3.531	3A-32
3.532	3A-24
3.534	3A-46
3.535	3A-33
3.536	3A-24
3.537	3B-14

3.ST46	3B-28	3.STZH3	3A-62
3.ST47	3B-5		
3.ST48	3A-51	3.ZN.75	3A-67
3.ST49	3A-57	3.ZN10	3A-20
3.ST50	3B-39	3.ZN13	3A-1
3.ST53	3A-61	3.ZN20	3A-57
3.ST54	3B-3	3.ZN23	3A-1
3.ST55	3A-51	3.ST25	3B-42
3.ST56	3A-53	3.ZN30	3A-9
3.ST56-2	3A-54	3.ZN33	3A-2
3.ST56-2	3A-55	3.ZN43	3A-2
3.ST58	3A-47	3.ZN48-PA	3A-18
3.ST60	3B-32	3.ZN60	3A-4
3.ST65	3B-32	3.ZN60	3A-9
3.ST67	3B-34	3.ZN65	3A-8
3.ST73	3A-62	3.ZN65	3A-9
3.ST76	3B-13	3.ZN66	3A-10
3.ST79	3B-40	3.ZN67	3A-15
3.ST81	3B-35	3.ZN68	3A-15
3.ST84	3B-35	3.ZN70	3A-67
3.ST89	3B-41	3.ZN80	3A-69
3.ST95	3B-21	3.ZN90	3A-68
3.ST96	3B-36	3.ZN100	3A-68
3.ST100	3B-26	3.ZN105	3A-21
3.ST102	3A-66	3.ZN110	3A-3
3.ST104	3B-40	3.ZN115	3A-3
3.ST105	3B-25	3.ZN120	3A-25
3.ST108	3A-52	3.ZN130	3A-26
3.ST109.001	3A-36	3.ZN140	3A-27
3.ST109.003	3A-37	3.ZN150	3A-70
3.ST109.004	3A-37	3.ZN151	3A-61
3.ST109.007	3A-38	3.ZN152	3A-61
3.ST109.009	3A-40	3.ZN154	3A-71, 72
3.ST109.100	3A-39	3.ZN155	3A-59
3.ST109.101	3A-39	3.ZN157	3A-72
3.ST112	3B-25	3.ZN158	3A-58
3.ST114	3A-48	3.ZN200	3A-20
3.ST115	3B-4	3.ZN210	3A-28, 29
3.ST116	3A-54		
3.ST117	3A-49		
3.ST118	3B-22		
3.ST119	3B-24		
3.ST120	3B-21		
3.ST121	3B-24		
3.ST123	3B-23		
3.ST125	3A-41		
3.ST126	3A-60		
3.ST127	3A-42, 43		
3.ST133	3A-46		
3.ST134	3A-56		
3.ST145	3A-50		
3.ST146	3A-50		
3.ST300	3B-48		
3.ST301	3B-49		
3.ST302	3B-50		
3.ST551	3B-45		
3.ST552	3B-45		
3.ST553	3B-45		
3.ST556	3B-15		
3.ST557	3B-15		
3.ST558	3B-46		
3.STZH2	3A-62		

[4] CLAMPS TYPE V-KLEMA

Single aluminium

25-120SW	4-1
35-240SW	4-1
50-240SW	4-1
70-300SW	4-1
95-300SW	4-1
25-120SW-B	4-1
50-300SW-B*	4-1
95-300SW-B	4-1
35-240SW-C	4-1
50-240SW-C	4-1

Double aluminium

2/25-120SW	4-2
2/50-240SW	4-2
2/70-300SW	4-2
2/25-120SW-B	4-2
2/35-300SW-B	4-2
2/25-120SW-D	4-2
2/50-240SW-D	4-2
2/70-300SW-E	4-2

2/25-120SW-E	4-2	NR.01.02	4-13
Aluminium		NR.01.03	4-13
16-120SW	4-3	NR.03.01	4-13
10-150.SW.A	4-3	NR.02.01	4-13
10-150.SW.B	4-3	NR.04.01	4-13
10-150.SW.C	4-3	NR.05.01	4-13
		NR.01.04	4-13
		NR.03.02	4-13
		NR.02.02	4-13
HS stalowe pojedyncze		Assembling busbar	
HM 6-50	4-4	4.480.001	4-14
HM 10-95/A	4-4	4.480.002.L	4-14
HM 10-95/B	4-4	4.480.002.L	4-14
HM 10-95/C	4-4	4.480.002.L	4-14
HM 25-150/A	4-4	4.480.003	4-14
HM 25-150/B	4-4	4.480.004	4-14
HS 6-50	4-4		
HS 10-95	4-4		
		[5] ACCESSORIES	
HS steel single		Adjustable feet	
HS 25-240	4-5	4.431	5-6
HS 50-240	4-5	4.510	5-7
HS 70-300	4-5	4.511	5-7
HS 35-300-B	4-5	4.512	5-7
HS 50-300-B	4-5	4.513	5-8
HS 120-300	4-5	4.514	5-8
		4.515	5-8
HS steel double		4.516	5-9
HS 2/50-240	4-6	4.517	5-9
HS 2/50-240-B	4-6	4.518	5-9
HS 2/50-240-D	4-6	Adjustable lever 4.530	5-10
HS 2/50-240-E	4-6	Air vent 4.107	5-23
HS 2/70-240-C	4-7	Air vent 4.108	5-23
HS 2/70-240-E	4-7	Air vent 4.109	5-23
HS 2/70-300	4-7	Box holder 4.410	5-14
		Bridge clamp system 4.411	5-4
HM steel double		Bridge clamp system 4.419	5-5
HM 2/10-70-A	4-8	Clamp 4.426	5-39
HM 2/10-70-B	4-8	Connector 4.429	5-5
		Connector 4.500	5-2
Connecting device RBK LZ6V	4-9	Document pocket 4.420	5-19
Terminals for connecting device 4.601.XXX	4-9	Door blockade 4.401.20X	5-13
Terminal 4.603.003	4-10	Door blockade 4.401.30X	5-13
Terminal 4.603.004	4-10	Door blockade 4.401	5-11
		Drawer handle 4.443	5-30
Terminals, clamps		Fixing pivot 4.427	5-39
4.406.XXX	4-11	Frame connector 4.422	5-17
4.405.XXX	4-11		
Cable clasp 4.460	4-15	Handle	
Cable clasp 4.461	4-15	4.102	5-31
Cable clasp 4.462	4-15	4.103	5-32
		4.104	5-32
V-klema covers		4.250	5-24
4.520.001.0X	4-12	4.440	5-25
		4.441	5-25
Surge protection clamp		4.444	5-24
4.402.001	4-12		
4.403.001	4-12		
Knurled nuts			
NR.01.00	4-13		

UT-81.4.....	6-14	US-328.2.....	6-16
UT-81.5.....	6-14	US-328.2.....	6-16
UT-82.2.....	6-14	US-328.2.....	6-16
UT-82.4.....	6-14		
UT-82.6.....	6-14	EMV gasketing material	
UT-83.....	6-14	UT-32.EMV.....	6-18
UTP-137.....	6-14	UT-33.3.EMV.....	6-18
UTB-1.....	6-9	UT-38.EMV.....	6-18
UTB-2.....	6-9	UT-42.EMV.....	6-18
UTB-9.....	6-9	UT-57A.EMV.....	6-18
		UT-57B.EMV.....	6-18
Self-Adhesive Profile		Sealing profiles from UR group meets norm EN 45545-2	
USRE-10.04.....	6-15	UR-4.4.01.....	6-19
USRE-15.03.....	6-15	UR-4.9.01.....	6-19
USRE-15.04.....	6-15	UR-8.2.....	6-19
USRE-20.04.....	6-15	UR-8.8.....	6-19
USDE-14.12.....	6-15	UR-8.9.....	6-20
UTK-10.11.....	6-15	UR-8.10.....	6-20
UTK-10.12.....	6-15	UR-8.11.....	6-20
USDE-15.15.....	6-15	UR-8.12.....	6-20
USPE-05.03.....	6-15	UR-32.....	6-21
USPE-08.02.....	6-15	UR-33.2.....	6-21
USPE-08.03.....	6-15	UR-38.....	6-21
USPE-10.02.....	6-15	UR-43.3.....	6-22
USPE-10.03.....	6-15	UR-43.5.....	6-22
USPE-10.04.....	6-15	UR-43.6.....	6-22
USPE-10.05.....	6-15	UR-57A.....	6-21
USPE-12.03.....	6-15	UR-80.5.....	6-22
USPE-12.04.....	6-15	UR-81.3.....	6-22
USPE-15.03.....	6-15		
USPE-15.04.....	6-15	Sealing profiles according to VDI 6022	
USPE-16.08.....	6-15	UT-8.2.VDI.....	6-23
USPE-18.05.....	6-15	UT-27.VDI.....	6-23
USPE-20.03.....	6-15	UT-32.VDI.....	6-23
USPE-20.05.....	6-15	UT-42.VDI.....	6-23
UTG-1.....	6-17	UT-57A.VDI.....	6-23
UTG-2.....	6-17		
UTF-1.....	6-17	[7] CUSTOM PRODUCTS	
UTGF-1.....	6-17	Custom products.....	7-1 to 7-6
UTGF-2.....	6-17		
Assembly profile			
US-828.....	6-16		
US-828.1.....	6-16		
US-828.2.....	6-16		
US-838.....	6-16		
US-838.2.....	6-16		
US-838.3.....	6-16		
US-838.4.....	6-16		
US-838.5.....	6-16		
US-838.6.....	6-16		
US-838.7.....	6-16		
US-838.8.....	6-16		
US-838.9.....	6-16		
US-838.10.....	6-16		
Wedge			
US-328.....	6-16		
US-328.2.....	6-16		
US-328.1.....	6-16		
US-328.2.....	6-16		
US-328.2.....	6-16		



ROZTOCZE





ROZTOCZE



GROUP RST

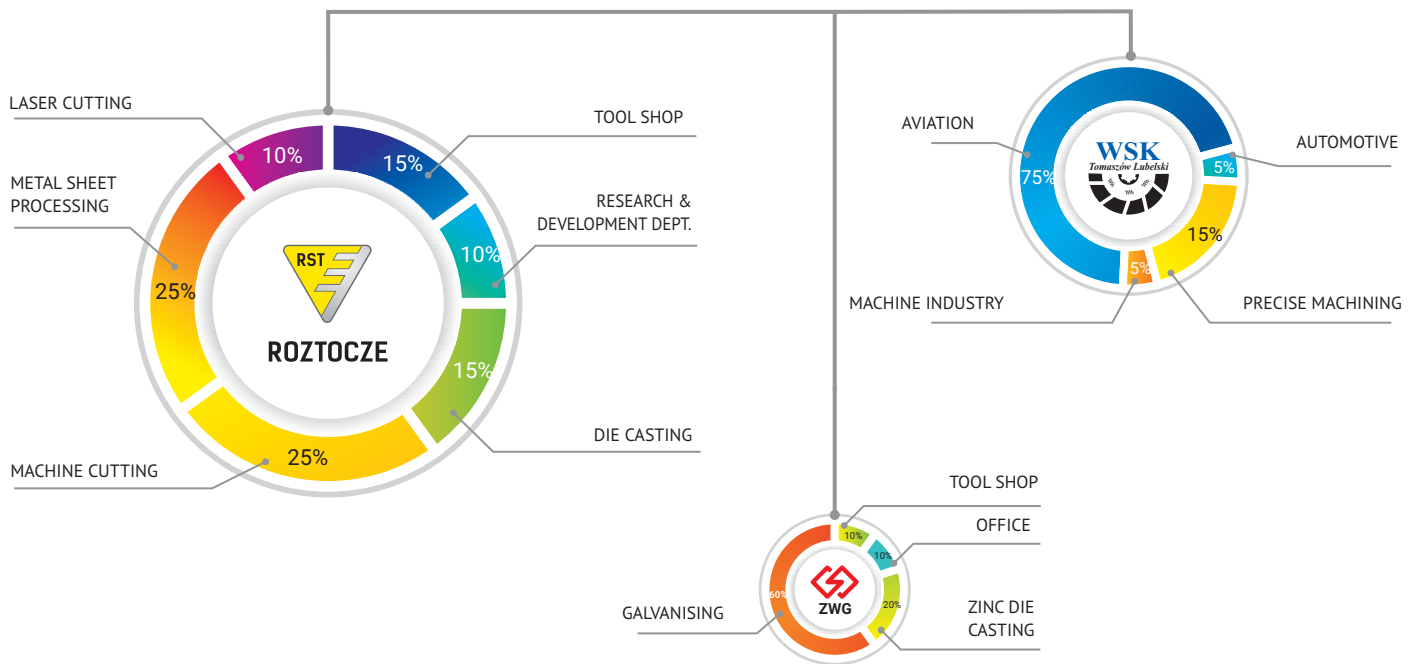

DISTRIBUTORS



ROZTOCZE

- BELARUS
MS Techno pro
Phone +375 29 651-63-70
mssm@tut.by
- BELGIUM, LUXEMBOURG
Mparts BV
Phone +32 (0) 3 232 3795
sales@mparts.be
- THE NETHERLANDS
Mparts BV
Phone +31 (0) 252 433 733
sales@mparts.nl

- CZECH REPUBLIC
Lidokov, výrobní družstvo
Phone +420 516 452 341
info@lidokov.cz
- FINLAND
MOREK Oy
Phone +358 40 7708030
reima@morek.fi
- FRANCE, SWITZERLAND
EPCI Engineering
Phone +33 (0)1 34 48 34 10
info@epcifrance.com
- ITALY
Trebi Srl
Phone +39 0444 497000
info@3bisrl.it
- SPAIN
FIXOR SL
Phone +34 93 710 41 60
info@fixor.es

- LITHUANIA, LATVIA, ESTONIA
UAB JVS IDEA
Phone +370 69377989
tdu@techpart.lt

- RUSSIA
RST, LLC
Phone +7 (4012) 611-346
info@rst.ooo

- UKRAINE
PP MARKA
Phone +38 (091) 305-0990
ppmarka@ukr.net

- GREAT BRITAIN, NORWAY, SWEDEN, HUNGARY, USA
TR Fastenings
Phone +44 1825 747460
sales@trfastenings.com



ROZTOCZE

ROZTOCZE Z.U.P. Roman Rak
22-600 Tomaszów Lubelski, Poland
ul. Zamojska 42A
Tel. +48 84 664 35 02

rst@roztocze.eu
www.roztocze.eu



X-ON Electronics

Largest Supplier of Electrical and Electronic Components

Click to view similar products for [Latches](#) category:

Click to view products by [Roztocze](#) manufacturer:

Other Similar products are found below :

[ML4875CS-5](#) [401639B](#) [716165RB](#) [74F373DW](#) [74LVC373ADTR2G](#) [74LVC573ADTR2G](#) [NL17SG373DFT2G](#) [NLV14044BDG](#) [5962-8863901RA](#) [5962-88639012A](#) [NLV14042BDR2G](#) [GN 115-VDE-16](#) [74AHC573PW,118](#) [2.L18.001-21](#) [2.PM18.002-18](#) [2.PM18.006-18](#) [2.T18.001-21](#) [2.T18.002-18](#) [2.T18.006-18](#) [CQ/AA-KEY](#) [CQ/A-M22X1,5-45-28](#) [CQ/A-M22X1,5-45-32](#) [M22-2-D5-2-21-01-P](#) [CY74FCT2373CTSOC](#) [421283](#) [MM74HC373WM](#) [MM74HC573WM](#) [74LCX373MTC](#) [74LVT16373MTDX](#) [74VHC373MX](#) [KLD5.001-02](#) [Z-0233-827-15](#) [MIC58P01YV](#) [74AHCT573D.112](#) [74LCX16373MTDX](#) [CQ/A-M22X1,5-45-16](#) [CQ/A-M22X1,5-45-18](#) [CQ/A-M22X1,5-45-20](#) [CQ/A-M22X1,5-45-24](#) [CQ/A-M22X1,5-45-30](#) [CQT/A-32-18 AE-V0](#) [CQT/A-32 20-AE-V0](#) [CY54FCT841ATDMB](#) [Z-2106-25001-22](#) [2.904.005](#) [2.904.006](#) [2.904.008](#) [2.KLB-D5.001PA-07](#) [2.KLB-T9.001PA-07](#) [2.KL-T9.002-02](#)