



PJM8205JDNSG-S

Dual N-Channel Enhancement Mode Power MOSFET

Product Summary

- $V_{DS} = 20V, I_D = 4A$
- $R_{DS(on)} < 30m\Omega @ V_{GS} = 4.5V$
- $R_{DS(on)} < 35m\Omega @ V_{GS} = 2.5V$

Features

- Advanced Trench Technology
- RoHS and Reach Compliant
- Halogen and Antimony Free
- Moisture Sensitivity Level 3

Application

- Load Switch
- PWM Applications
- Power Management

Marking Code

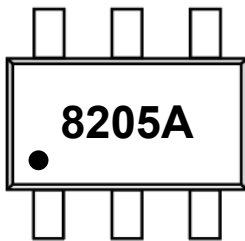

SOT-23-6

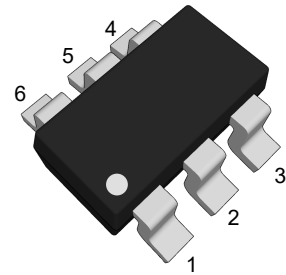

(Top View)

Pin	Description	Pin	Description
1	Source1	4	Gate2
2	Drain1/Drain2	5	Drain1/Drain2
3	Source2	6	Gate1

Schematic Diagram

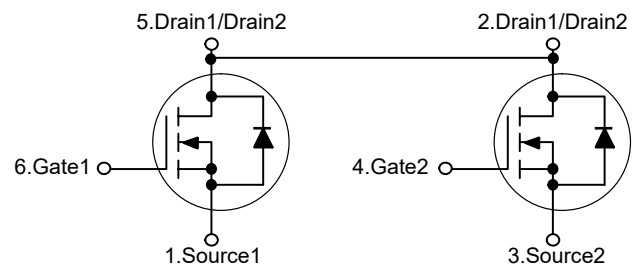

Absolute Maximum Ratings

Ratings at 25°C ambient temperature unless otherwise specified.

Parameter	Symbol	Value	Unit
Drain-Source Voltage	V_{DS}	20	V
Gate-Source Voltage	V_{GS}	± 12	V
Drain Current-Continuous	I_D	4	A
Drain Current-Pulsed ^{Note1}	I_{DM}	15	A
Maximum Power Dissipation	P_D	1	W
Junction Temperature	T_J	150	°C
Storage Temperature Range	T_{STG}	-55 to +150	°C

Thermal Characteristics

Thermal Resistance, Junction-to-Ambient ^{Note2}	$R_{\theta JA}$	125	°C/W
--	-----------------	-----	------



PJM8205JDNSG-S

Dual N-Channel Enhancement Mode Power MOSFET

Electrical Characteristics

(Ta=25°C unless otherwise specified)

Parameter	Symbol	Test Condition	Min.	Typ.	Max.	Unit
Static Characteristics						
Drain-Source Breakdown Voltage	$V_{(BR)DSS}$	$V_{GS}=0V, I_D=250\mu A$	20	--	--	V
Zero Gate Voltage Drain Current	I_{DSS}	$V_{DS}=20V, V_{GS}=0V$	--	--	1	μA
Gate-Body Leakage Current	I_{GSS}	$V_{GS}=\pm 12V, V_{DS}=0V$	--	--	± 100	nA
Gate Threshold Voltage ^{Note3}	$V_{GS(th)}$	$V_{DS}=V_{GS}, I_D=250\mu A$	0.4	0.65	1	V
Drain-Source On-Resistance ^{Note3}	$R_{DS(on)}$	$V_{GS}=4.5V, I_D=4A$	--	23	30	m Ω
		$V_{GS}=2.5V, I_D=3A$	--	28	35	m Ω
Forward Transconductance ^{Note3}	g_{FS}	$V_{DS}=5V, I_D=1A$	--	7	--	S
Dynamic Characteristics						
Input Capacitance	C_{iss}	$V_{DS}=10V, V_{GS}=0V, f=1MHz$	--	340	--	pF
Output Capacitance	C_{oss}		--	82	--	pF
Reverse Transfer Capacitance	C_{rss}		--	56	--	pF
Gate Resistance	R_G	$V_{DS}=0V, V_{GS}=0V, f=1MHz$	--	25	--	Ω
Total Gate Charge	Q_g	$V_{DS}=10V, I_D=3A,$ $V_{GS}=0V\sim 4.5V$	--	5.2	--	nC
Gate-Source Charge	Q_{gs}		--	0.9	--	nC
Gate-Drain Charge	Q_{gd}		--	1.1	--	nC
Switching Characteristics						
Turn-on Delay Time	$t_{d(on)}$	$V_{DD}=10V, I_D=3A$ $V_{GS}=4V, R_{GEN}=3\Omega$	--	4	--	nS
Turn-on Rise Time	t_r		--	28	--	nS
Turn-off Delay Time	$t_{d(off)}$		--	66	--	nS
Turn-off Fall Time	t_f		--	50	--	nS
Source-Drain Diode Characteristics						
Diode Forward Voltage ^{Note3}	V_{SD}	$V_{GS}=0V, I_S=4A$	--	--	1.2	V
Diode Forward Current ^{Note2}	I_S		--	--	4	A

Note: 1. Repetitive Rating: Pulse width limited by maximum junction temperature.

2. Surface Mounted on FR4 Board, $t \leq 10$ sec.

3. Pulse Test: Pulse width $\leq 300\mu s$, duty cycle $\leq 2\%$.



Typical Characteristic Curves

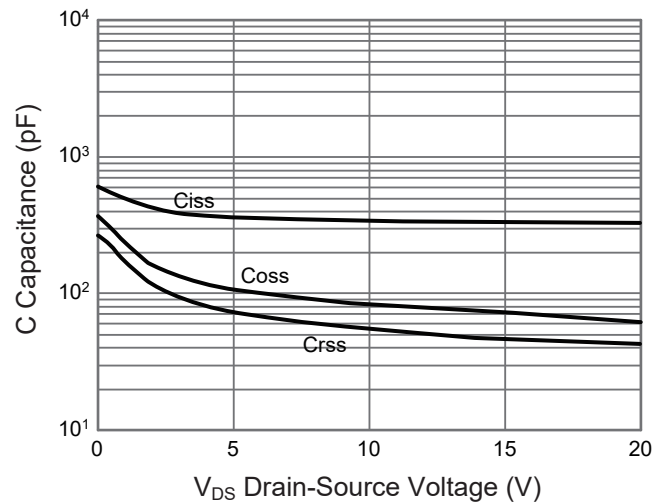
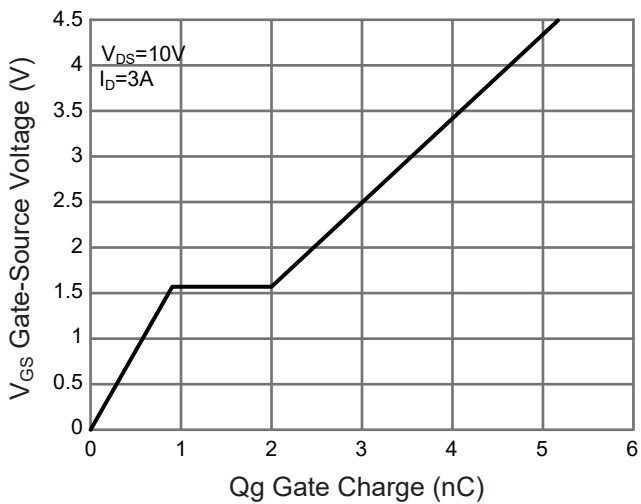
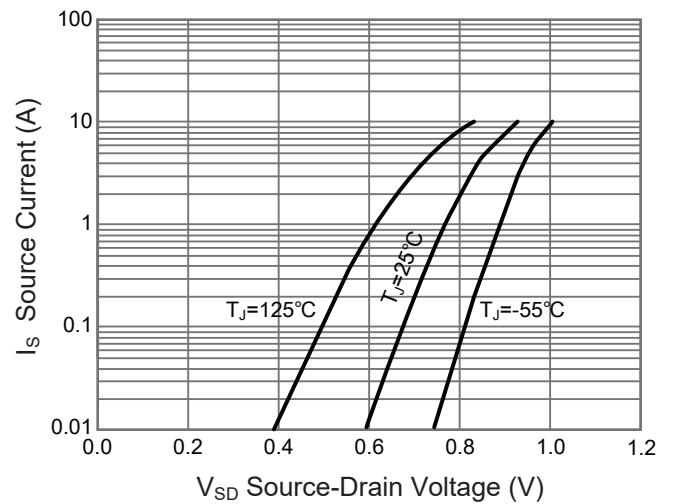
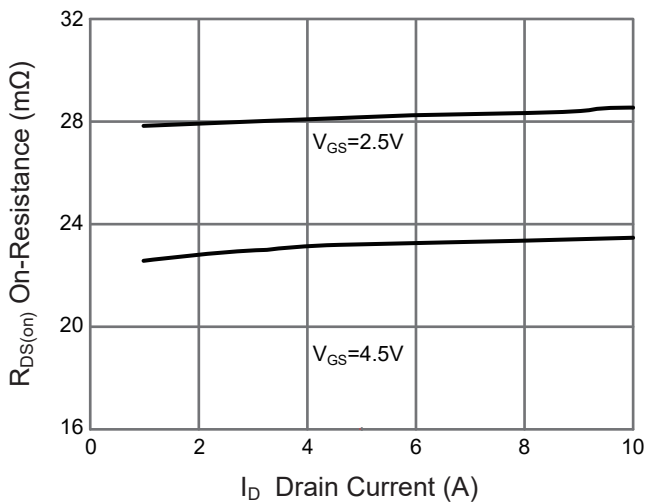
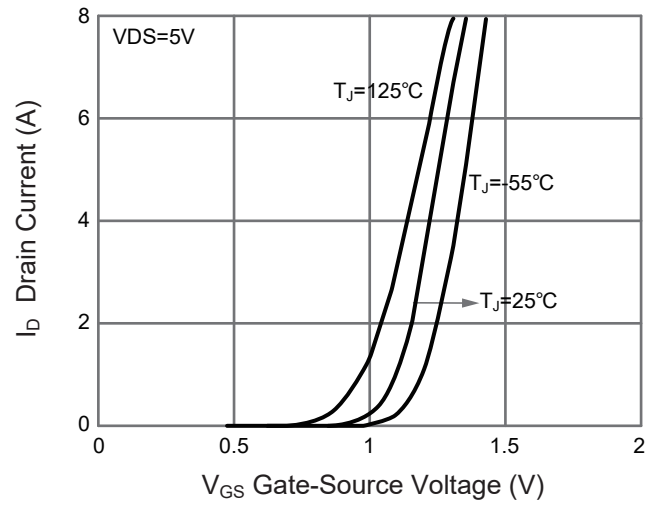
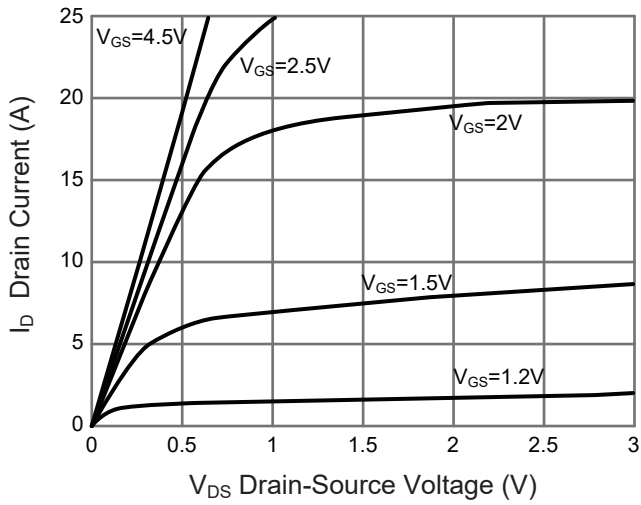



PJM8205JDNSG-S

Dual N-Channel Enhancement Mode Power MOSFET

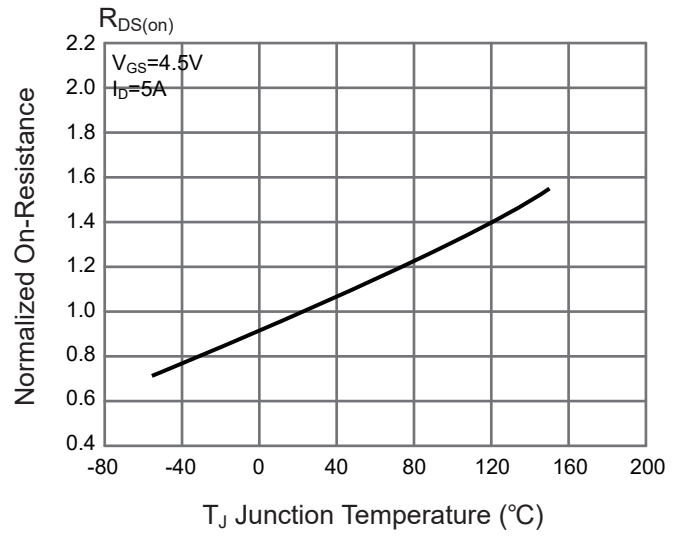
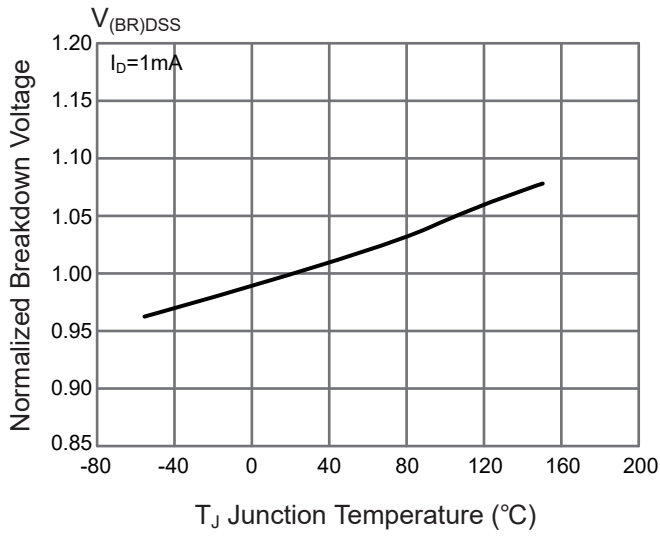



PJM8205JDNSG-S

Dual N-Channel Enhancement Mode Power MOSFET

Package Outline

SOT-23-6

Dimensions in mm

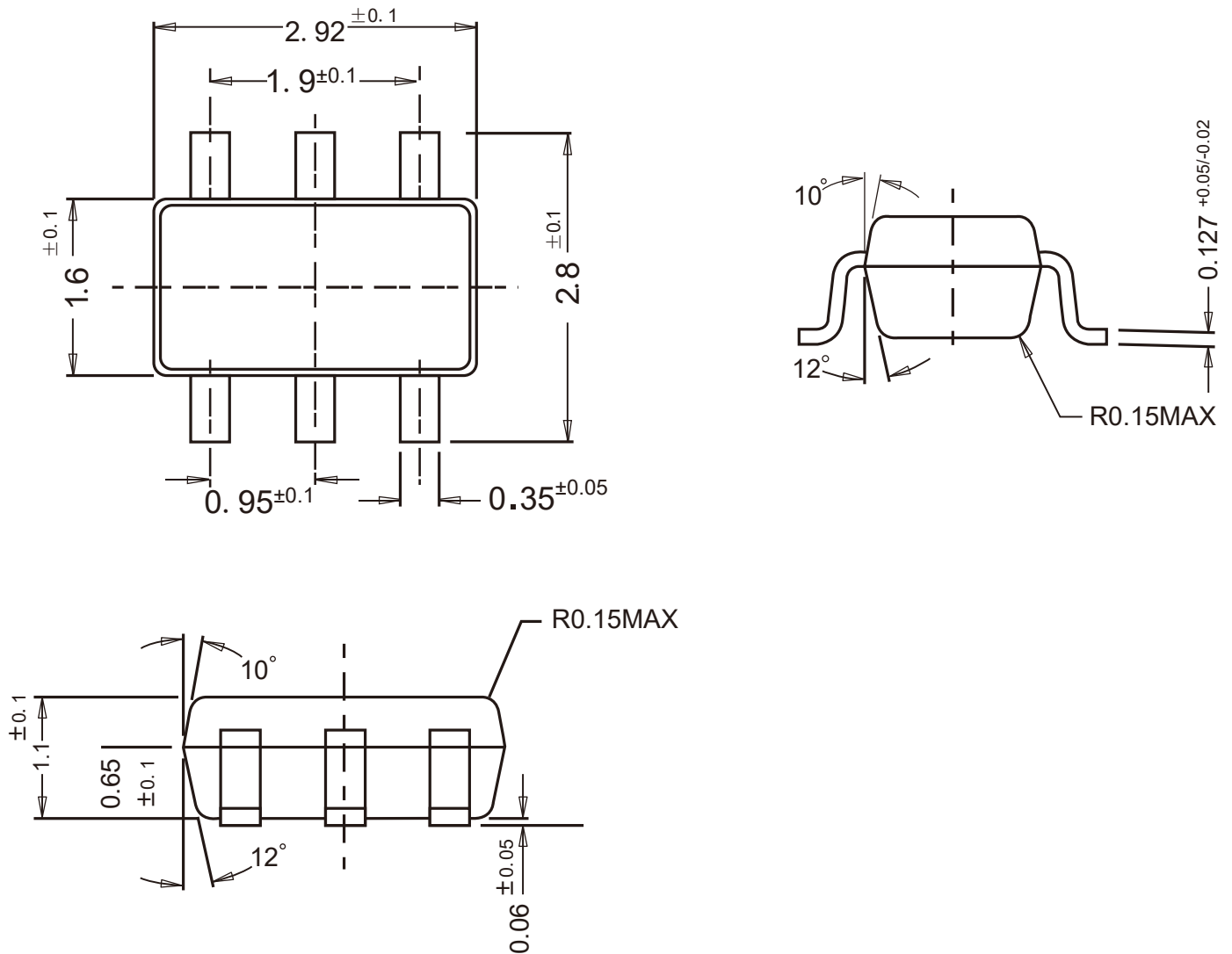

Ordering Information

Device	Package	Shipping
PJM8205JDNSG-S	SOT-23-6	3,000PCS/Reel&7inches



Conditions of Soldering and Storage

◆ Recommended condition of reflow soldering

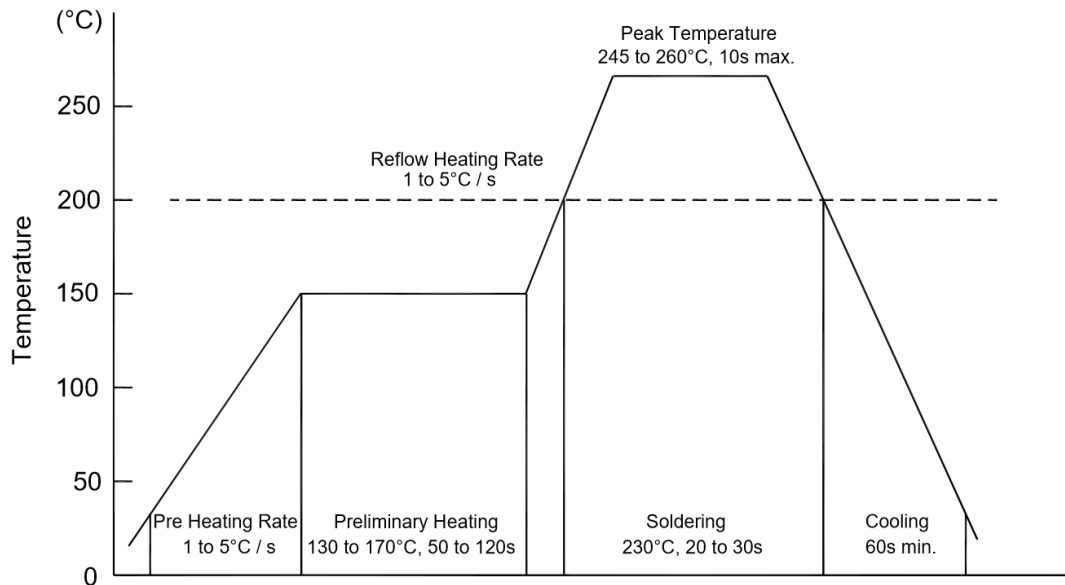

Recommended peak temperature is over 245 °C. If peak temperature is below 245 °C, you may adjust the following parameters:

- Time length of peak temperature (longer)
- Time length of soldering (longer)
- Thickness of solder paste (thicker)

◆ Conditions of hand soldering

- Temperature: 370 °C
- Time: 3s max.
- Times: one time

◆ Storage conditions

- **Temperature**
5 to 40 °C
- **Humidity**
30 to 80% RH
- **Recommended period**
One year after manufacturing



PJM8205JDNSG-S

Dual N-Channel Enhancement Mode Power MOSFET

Package Specifications

- The method of packaging

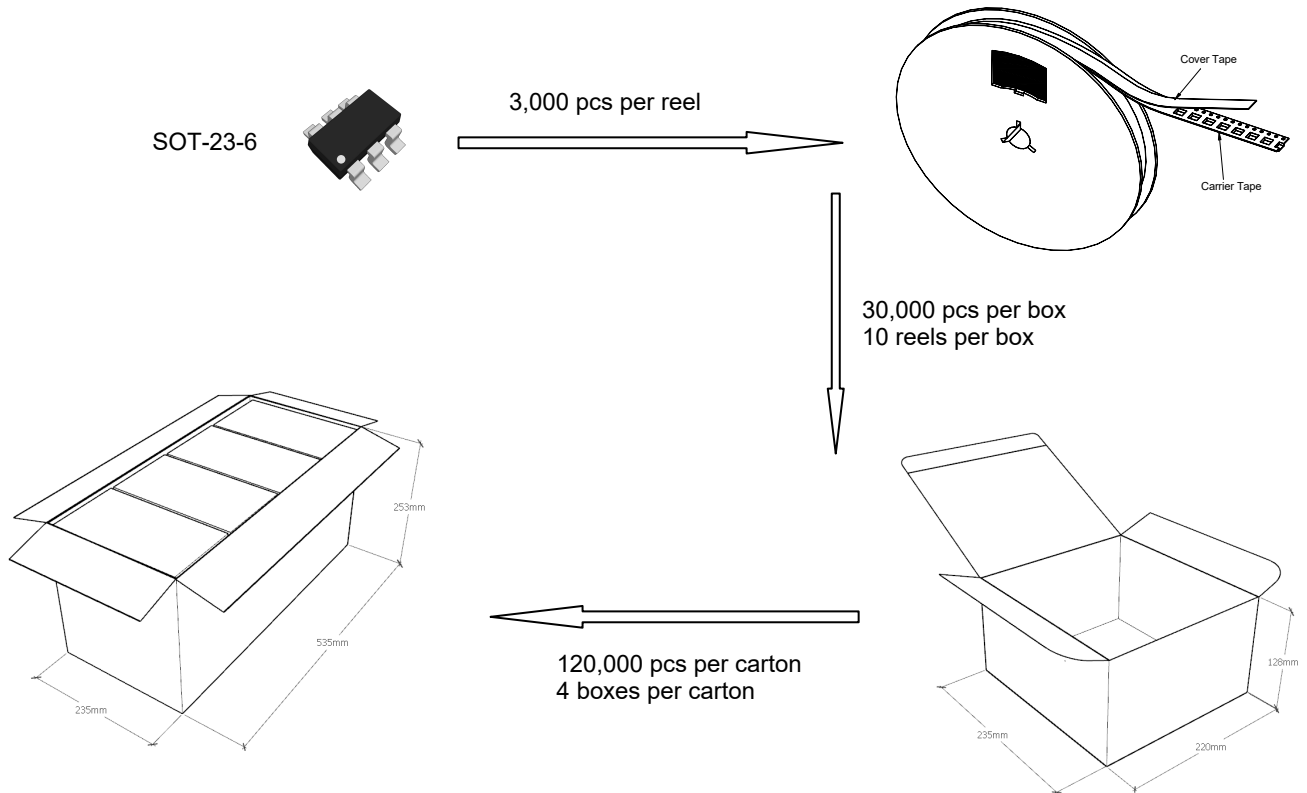

◆ Embossed tape and reel data

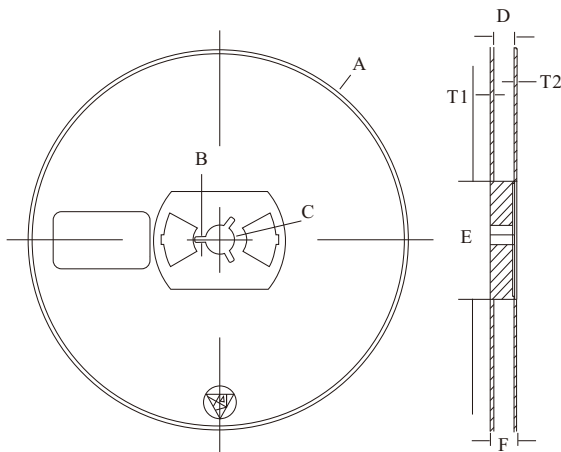

Symbol	Value (unit: mm)
A	Ø 177.8±1
B	2.7±0.2
C	Ø 13.5±0.2
E	Ø 54.5±0.2
F	12.3±0.3
D	9.6+2/-0.3
T1	1.0±0.2
T2	1.2±0.2

Reel (7")

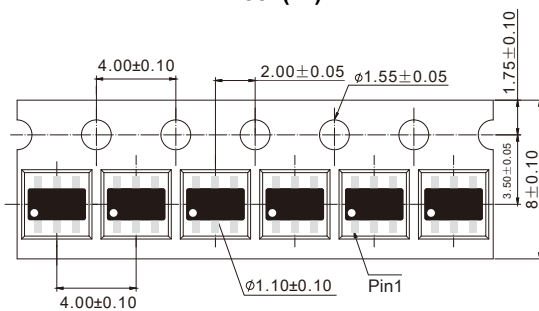

Tape (8mm)

X-ON Electronics

Largest Supplier of Electrical and Electronic Components

Click to view similar products for [MOSFETs](#) category:

Click to view products by [Pingjingsemi](#) manufacturer:

Other Similar products are found below :

[MCH3443-TL-E](#) [MCH6422-TL-E](#) [NTNS3A92PZT5G](#) [IRFD120](#) [2SK2464-TL-E](#) [2SK3818-DL-E](#) [2SJ277-DL-E](#) [2SK2267\(Q\)](#) [MIC4420CM-TR](#) [IRFS350](#) [IPS70R2K0CEAKMA1](#) [AON6932A](#) [TS19452CS RL](#) [2SK2614\(TE16L1,Q\)](#) [DMN1017UCP3-7](#) [EFC2J004NUZTDG](#) [SCM040600](#) [NTE2384](#) [2N7000TA](#) [DMN2080UCB4-7](#) [DMN61D9UWQ-13](#) [US6M2GTR](#) [DMN31D5UDJ-7](#) [DMP22D4UFO-7B](#) [DMN1006UCA6-7](#) [DMN16M9UCA6-7](#) [STF5N65M6](#) [IRF40H233XTMA1](#) [STU5N65M6](#) [DMN6022SSD-13](#) [DMN13M9UCA6-7](#) [STU7N60DM2](#) [DMTH10H4M6SPS-13](#) [DMN2990UFB-7B](#) [2N7002W-G](#) [MCQ7328-TP](#) [IPB45P03P4L11ATMA2](#) [BXP4N65F](#) [BXP2N20L](#) [BXP2N65D](#) [TSM60NB380CP ROG](#) [SLF10N65ABV2](#) [IRF9395MTRPBF](#) [FCMT080N65S3](#) [NTD5C632NLT4G](#) [NTMFS0D55N03CGT1G](#) [NTMFS1D15N03CGT1G](#) [NTMTS0D4N04CTXG](#) [NTMYS2D1N04CLTWG](#) [NVD360N65S3T4G](#)