

A PERFECT ALLIANCE.

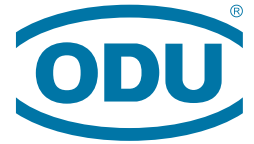

ODU-MAC[®] **Blue-Line**

A new performance class.

Up to 2,500 V, 12 bar, 10 Gbit/s, > 10,000 mating cycles and 12.0 GHz

MANUAL MATING
AUTOMATIC DOCKING



ODU-MAC[®] BLUE-LINE

ODU-MAC[®] SILVER-LINE | ODU DOCK SILVER-LINE

ODU-MAC[®] WHITE-LINE

FEATURES

- Economical, efficient solution
- Rugged version
- > 10,000 mating cycles
- Modules assembled flexibly and conveniently using the clip principle
- Low contact resistances
- High reliability
- Maximum packing density

APPLICATIONS

- Medical
- Industrial
- Test and measurement
- Military and security
- Energy
- eMobility



Data transmission protocols

These ODU-specific connectors can transmit common data transmission protocols such as USB® 1.1, USB® 2.0, USB® 3.1 Gen1, FireWire®, FlexRay®, Ethernet, Profibus®, CAN-Bus, CAT 5, and CAT 6_x, but they are not USB®, FireWire®, FlexRay®, Ethernet, Profibus®, CAN-Bus or CAT standard connectors.

All the connectors shown here are connectors without breaking capacity (COC) according to IEC 61984:2008 (VDE 0627:2009).

The majority of ODU-MAC® modules and contacts have been certified according to UL 1977/CSA C22.2 no. 182.3 (E file no.: E110586) and tested to MIL/SAE/EIA.

Issue: 2019-10

TABLE OF CONTENTS

Clickable
page numbers

THE ODU CORPORATE GROUP	<u>4</u>
PRODUCT INFORMATION	<u>10</u>
The ODU-MAC® Blue-Line – a new performance class	<u>12</u>
ODU-MAC® Blue-Line Web Configurator	<u>16</u>
Your way to an individual connection	<u>18</u>
ODU-MAC® PUSH-LOCK	<u>20</u>
The best connections for manual mating	<u>22</u>
Information on the plastic housing	<u>30</u>
Automatic docking	<u>32</u>
Best connections – the contact principle	<u>34</u>
Contact retention with the clip principle (standard)	<u>36</u>
PCB termination modules	<u>38</u>
The ODU-MAC® Blue-Line – for the most varied applications	<u>39</u>
MANUAL MATING	<u>40</u>
ODU-MAC® PUSH-LOCK	<u>42</u>
Spindle locking	<u>44</u>
Metal housing	<u>48</u>
Plastic housing	<u>52</u>
Transverse locking, plastic housing	<u>59</u>
Lever locking, metal housing	<u>64</u>
Frame for housing	<u>72</u>
Accessories	<u>73</u>
Coding options	<u>76</u>
AUTOMATIC DOCKING	<u>82</u>
Requirements of the complete system	<u>84</u>
ODU-MAC® Blue-Line docking frame	<u>86</u>
ODU-MAC® Blue-Line strain-relief housing	<u>87</u>
MODULES	<u>90</u>
Overview	<u>92</u>
Signal	<u>98</u>
PCB termination modules	<u>106</u>
Power	<u>114</u>
High current	<u>116</u>
Coax	<u>122</u>
Compressed air and fluid coupling with M5 termination accessories	<u>130</u>
Shielded feedthrough/high-speed connector	<u>138</u>
Combination module	<u>144</u>
Fiber optic	<u>148</u>
Blank modules	<u>150</u>
TOOLS, CRIMP INFORMATION, PROCESSING INSTRUCTIONS, ACCESSORIES	<u>152</u>
TECHNICAL INFORMATION	<u>162</u>

For assembly instructions, please refer to our website: www.odu-connectors.com/downloads

A PERFECT ALLIANCE.

Creating connections, building alliances, collaborating into the future: Whether two technical components come together to form a unit or people come together to strive for great results – the key is to aspire to achieve superb results. This goal drives our work. **Perfect connections that inspire and deliver on the promises.**



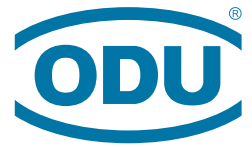

A PERFECT ALLIANCE.

” WORLDWIDE CUSTOMER PROXIMITY

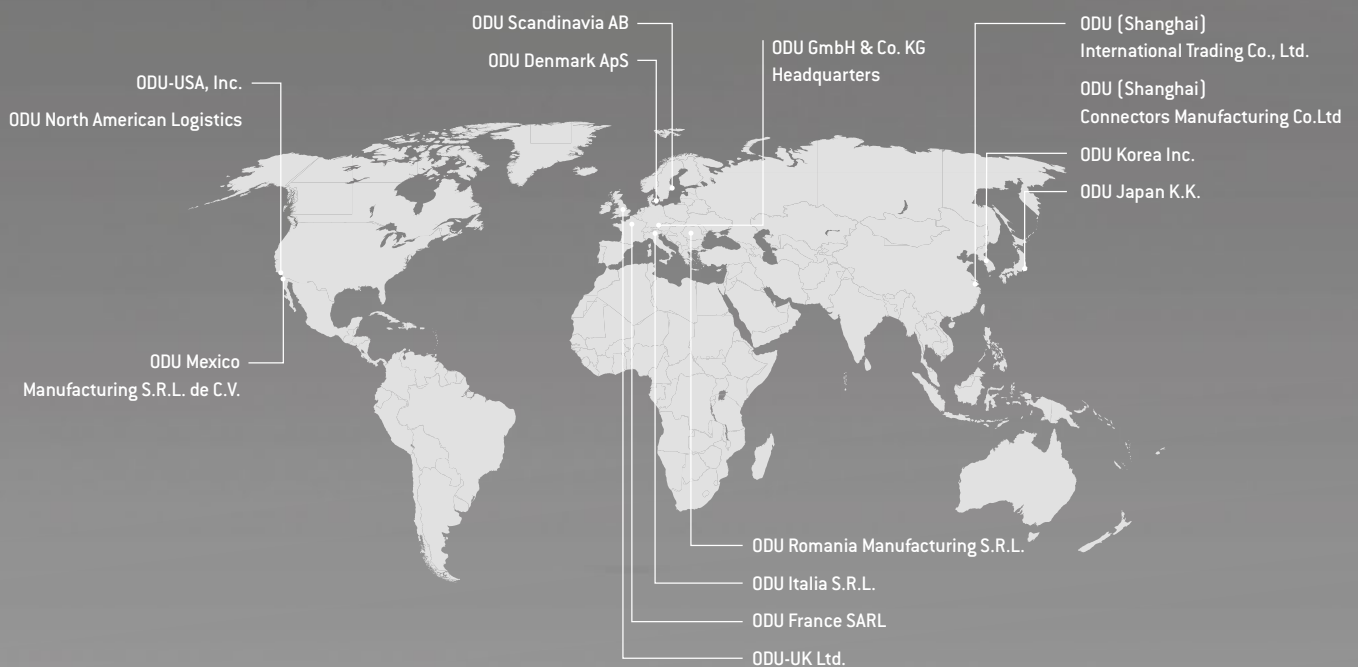

ODU GROUP OVERVIEW

- More than 75 years of experience in connector technology
- A turnover of € 200 million
- Over 2,300 employees worldwide
- Sales subsidiaries in China, Denmark, France, Germany, Italy, Japan, Korea, Sweden, UK and the US as well as 5 production and logistics sites
- All technologies under one roof: Design and development, machine tool and special machine construction, injection, stamping, turning, surface technology, assembly and cable assembly

As of February 2019

CERTIFICATES & APPROVALS

- ISO 9001
- IATF 16949
- ISO 13485
- ISO 14001
- ISO 50001
- Wide range of UL, CSA, VG and VDE approvals
- UL Wiring Harnesses certified

For a complete list of our certifications and approvals, please visit our website.

INGENIOUS IDEAS

PERFECT SOLUTIONS

Product portfolio of ODU



ELECTRICAL CONTACTS

- Versatile connector technologies
- Outstanding reliability, lifetime and durability
- Up to 1 million mating cycles
- Current-carrying capacity of up to 2,400 A
- Rugged contact systems, suitable even for harsh environments
- Economical solutions for automatic processing
- Including cable assembly – complete solution



CIRCULAR CONNECTORS

- Circular connector series in robust metal or plastic housing
- Contacts for soldering, crimping and PCB termination
- Optional selectable Push-Pull locking or screw locking technology ensuring a secure connection at all times as well as easy to release Break-Away function
- 2 up to 55 contacts
- IP50 to IP69
- Autoclavable for medical applications
- Hybrid inserts for combined transmission
- Including cable assembly – complete solution



MODULAR CONNECTORS

- Application-specific hybrid interface
- For manual mating and automatic docking
- The highest packing density
- Flexible modular construction
- Multitude of data transmission modules
- For the transmission of signals, power, high current, high voltage, HF signals (coax), media, high-speed data and fiber optics
- Variety of locking options available
- Extremely durable – even under extreme conditions
- Mating cycles scalable as required from 10,000 to over 100,000 (1 million)
- Including cable assembly – complete solution

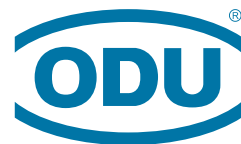

A PERFECT ALLIANCE.

” VERSATILE CONNECTOR SOLUTIONS FOR A WIDE RANGE OF APPLICATIONS



HEAVY DUTY CONNECTORS

- Extremely durable even under extreme / harsh environments
- High vibration resistance
- Up to 400 A (higher currents upon request)

PRINTED CIRCUIT BOARDS CONNECTORS



- Maximum flexibility in application designs
- High resilience and outstanding quality
- Including cable assembly – complete solution



APPLICATION AND CUSTOMER-SPECIFIC SOLUTIONS

- Contacts, connectors and cable assemblies for the highest technical requirements as well as special applications
- First-class implementation expertise
- High level of vertical manufacturing – all competences and key technologies under one roof
- Expert advice based on mutual partnership
- Short development and production paths



CABLE ASSEMBLY

- Complete systems from a single source based on years of expertise
- State-of-the-art production facilities with 100 % end testing
- Cleanroom production
- Overmolding in silicone, hot-melt and high-pressure procedures
- Customer-specific labeling
- Prototype, small series and high volume production
- Rapid prototyping

MORE THAN A CONNECTION

Our Know-How for your success



HIGH PERFORMANCE CONNECTOR TECHNOLOGY FOR DEMANDING KEY MARKETS

Customers rely on ODU technology wherever first-class, high-performance connector solutions are required. All our skills go into our products to ensure your success.

In addition to the top quality, reliable stability and maximum flexibility our products also stand for dynamics, reliability, safety, precision, efficiency and sustainability.

ODU – A PERFECT ALLIANCE.

CONNECTIONS THAT LIVE UP TO ANY REQUIREMENT

Contacts, connectors and integrated cable assembly solutions meeting the most demanding technical market requirements – ODU's connector solutions and value-added services are characterized by their exclusive focus on meeting the customer's needs.

- Precise implementation of application-specific requirements regarding design, functionality, cost and exclusivity
- Modified connector solutions derived from standard products
- One-to-one local expertise and fair, friendly consulting
- Short development and production paths

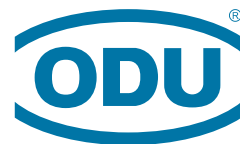

A PERFECT ALLIANCE.

” CROSS-INDUSTRY KNOW-HOW

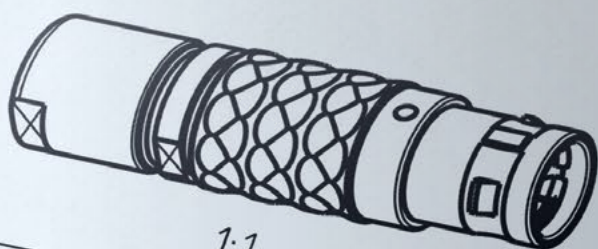

Part Number	Length Range
L_C-P03MSNO-9900	> 9.0 - 9.9 mm
L_C-P03MSNO-9200	> 8.0 - 9.2 mm
L_C-P03MSNO-8200	> 7.0 - 8.2 mm
L_C-P03MSNO-7200	> 6.0 - 7.2 mm
L_C-P03MSNO-6200	> 5.0 - 6.2 mm
L_C-P03MSNO-5200	> 4.0 - 5.2 mm
L_C-P03MSNO-4200	> 3.0 - 4.2 mm
L_C-P03MSNO-3200	> 2.0 - 3.2 mm

Kabel Ø
cable Ø



MEDICAL



TEST AND MEASUREMENT

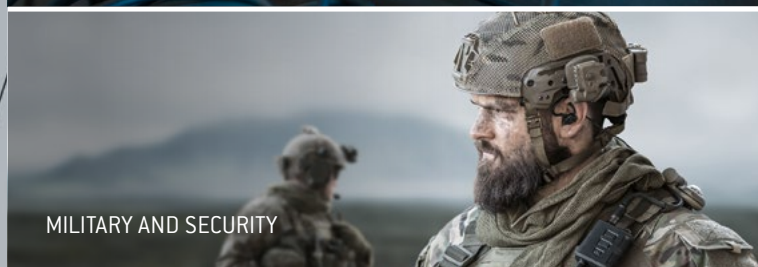

MILITARY AND SECURITY

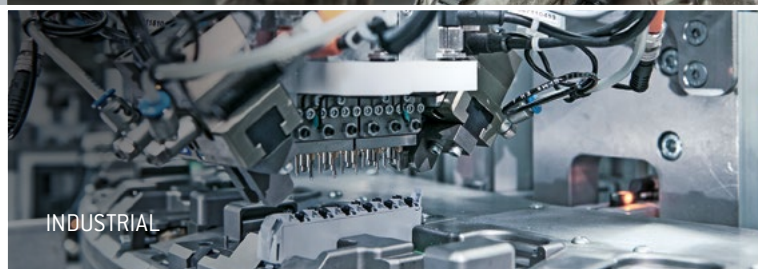

INDUSTRIAL



ENERGY



EMOBILITY

DEVELOPMENT OF CUSTOM SOLUTIONS

Demands that can't be pigeon-holed call for creative specialists who think outside the box. ODU offers the type of expertise that focuses solely on the specific requirements of our customers.

For every development order we get, we not only perform a thorough check to make sure it's feasible, we intensively incorporate our customers in the ongoing design process. This guarantees impressive, custom-fit final end products.



EASILY CONFIGURE THE ODU-MAC® BLUE-LINE
ONLINE AT: WWW.ODU-MAC.COM/EN/

ODU-MAC®



PRODUCT INFORMATION

The ODU-MAC® Blue-Line – a new performance class	<u>12</u>
ODU-MAC® Blue-Line Web Configurator	<u>16</u>
Your way to an individual connection	<u>18</u>
ODU-MAC® PUSH-LOCK	<u>20</u>
The best connections for manual mating	<u>22</u>
Information on the plastic housing	<u>30</u>
Automatic docking	<u>32</u>
Best connections – the contact principle	<u>34</u>
Contact retention with the clip principle [standard]	<u>36</u>
PCB termination modules	<u>38</u>
The ODU-MAC® Blue-Line – for the most varied applications	<u>39</u>

THE ODU-MAC[®] BLUE-LINE – A NEW PERFORMANCE CLASS

MANUAL MATING



The ODU-MAC[®] Blue-Line is a convenient, hybrid manual-connector solution comprising a stable frame, various modules, and a housing. Its modular design enables it to combine many individual connections in one ODU-MAC[®] Blue-Line. The proven ODU spindle locking in the new standard plastic housing provides the ODU-MAC[®] Blue-Line with a truly unique selling point on the market.

The economical connector system is a modular all-around solution that can be configured for the smallest installation space – available in both a plastic and a metal housing. A multitude of data transmission modules allow for a broad area of

application as a service and interface connector, such as in mechanical engineering, in measurement and testing, as well as in medical technology. The simple, exceptionally user-friendly assembly and removal of the crimp-clip contacts, even if they have already been assembled, distinguish the ODU-MAC[®] Blue-Line as well; any module installation errors are prevented via one mechanical and two optical coding functions. The cost-effective and proven ODU contact technology – turned and slotted contacts – with at least 10,000 mating cycles, as well as the simple processing of the contacts and modules, underscores the economical nature of the system.

+ Economical

+ Flexible

+ Robust

+ High-performance

AUTOMATIC DOCKING

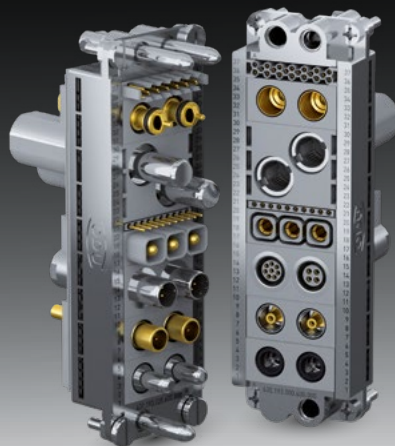

VARIOUS MODULES



ECONOMICAL

- Easy assembly using crimp contacts, which are clipped into the insulators
- Quick assembly and removal of the modules in the frame without using tools
- Removal of the contacts from the mating side

ROBUST

- Centering, guiding, and grounding via guiding sockets and pins
- Numerous housing versions in metal and plastic available with spindle or lever locking

FLEXIBLE

- 5 frame sizes (7, 12, 18, 26, 37 units)
- Transmission of signals, power, high current, coax, compressed air, fluid, data, and fiber optics
- Additional option for the transmission of signals: separate PCB termination modules for effective contacting in the termination area
- Maximum packing density via the 2.4 mm grid (1 unit)

HIGH-PERFORMANCE

- > 10,000 mating cycles
- Up to 370 contacts per single-row connector
- Proven ODU contact technology (turned/slotted contacts and contacts with lamella technology)

A MODULAR ALL-ROUNDER

The flexible modular design of the ODU-MAC® Blue-Line enables the combination of the most varied types of transmission within a connector. Whether signal, power, high current, coax, compressed air, fluid, data or fiber optics are being transmitted – all of the contact inserts can be selected from the modular system and integrated into the individual connector solution. For signal transmission, there is also a simple contacting option using PCB termination modules. The mating options are equally versatile.

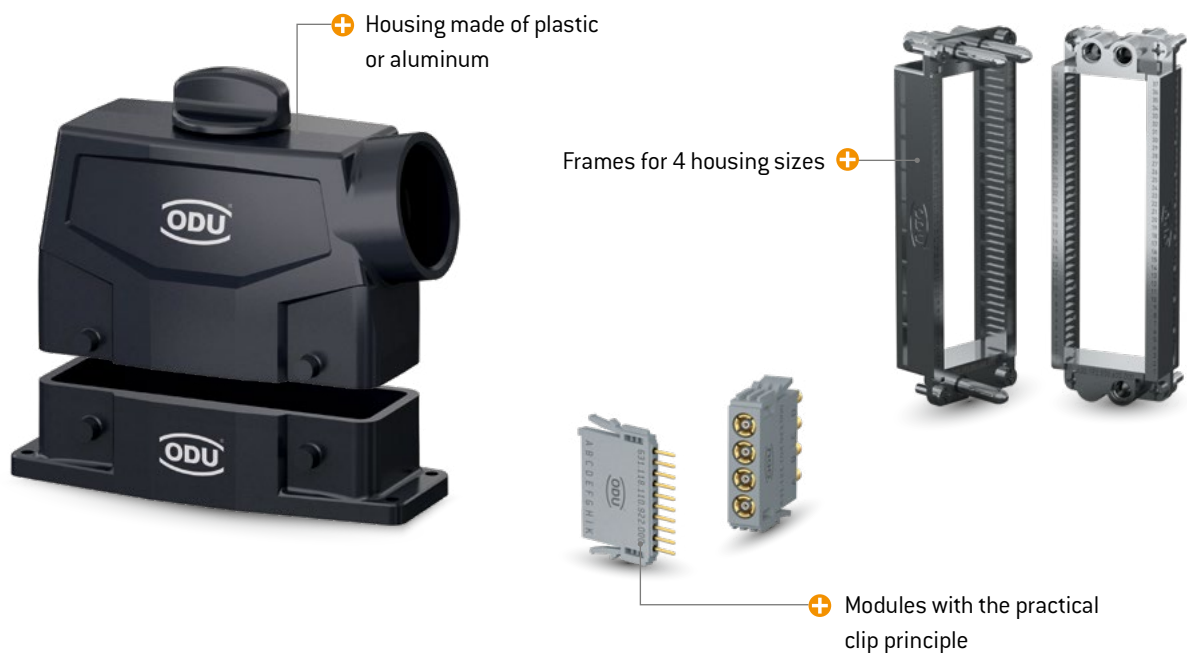

THE INTELLIGENT WAY TO AN INDIVIDUAL CONNECTION

There are many possibilities available here for the most varied applications: for example, installed in a stable frame for rack-and-panel applications or in one of the many housing versions.

This results in an effective, compact, and attractive overall connection that cannot be beaten in terms of functionality. The confusion caused by many connections is a thing of the past – an ODU-MAC® Blue-Line customized to meet your requirements is today's solution.

Learn more about custom configurations on the following pages or at: www.odu-mac.com/en/

ODU-MAC® **Silver-Line** / **White-Line**

Our ODU-MAC® Silver-Line and White-Line offer a more comprehensive portfolio – request our catalog to find out more.



FIND OUT MORE IN THE VIDEOS AT
www.youtube.com/ODUSteckverbinder

THE MODULAR SYSTEM AT A GLANCE:

10,000
mating cycles
and more

2 possible areas of application:
manual mating or
automatic docking

39 cable hood versions

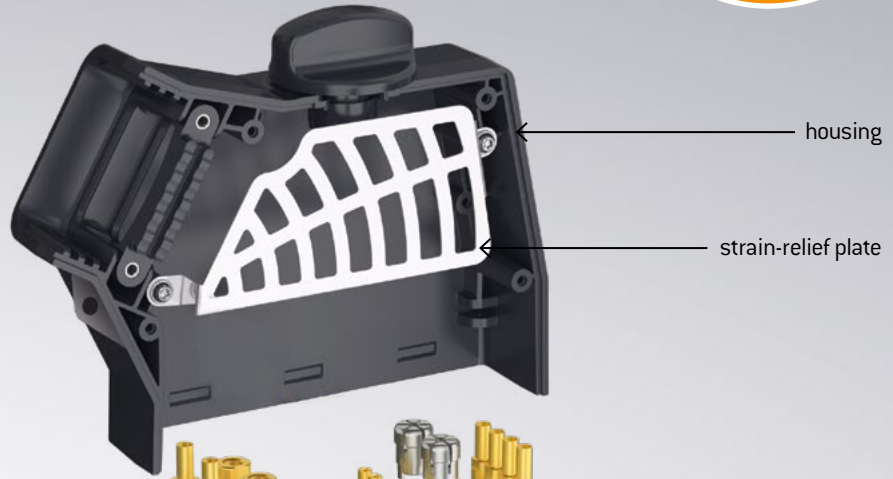

housing

strain-relief plate

4 types of locking: spindle,
lever, transverse or
push-pull locking

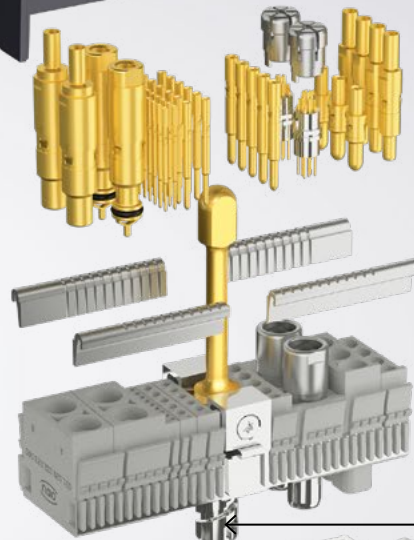

contacts for
solder, crimp, and
PCB termination

28 modules to choose from: signal, power,
high current, coax, compressed air, fluid,
data transmission, fiber optic, and PCB
termination

3 different spindle
geometries



spindle locking

pin frame

Contacts with the clip principle
that can be dismantled
(see page 36)

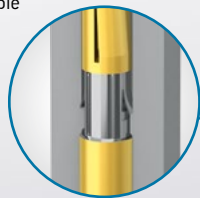

socket frame

14 versions of the bulkhead and surface-
mounted housings and couplings in
various sizes



housing

ODU-MAC® BLUE-LINE WEB CONFIGURATOR

The individual configuration of your ODU-MAC® Blue-Line connector

The ODU-MAC® Blue-Line Web Configurator offers you the possibility of conveniently configuring your connector online according to your requirements. The Configurator guides you step by step through the various selection options and offers much additional information. There are 3 ways to access the ODU-MAC® Blue-Line Web Configurator:

1. ACCESS: THROUGH WWW.ODU-CONNECTORS.COM



Entry via www.odu-connectors.com provides you with a great deal of product information and many application examples prior to configuration of your ODU-MAC® Blue-Line.



You access the Configurator via the Modular Connectors product category.

2. ACCESS: DIRECTLY THROUGH WWW.ODU-MAC.COM/EN/



www.odu-mac.com/en/ takes you directly to the configuration interface, allowing you to start assembling your ODU-MAC® Blue-Line immediately.

3. ACCESS: THROUGH WWW.ODU-CONNECTORS.COM/BLUE-LINE/



Click the “Configurator” button on the www.odu-connectors.com/blue-line/ landing page to go to the Web Configurator.

YOUR WAY TO AN INDIVIDUAL CONNECTION

How to configure your ODU-MAC® Blue-Line.

INDIVIDUAL REQUIREMENTS – INDIVIDUAL CONFIGURATION

With ODU-MAC® Blue-Line, we offer a modular connector system configured to your exact requirements. This means that you always receive the appropriate hybrid connection for a perfect interface.

SELECT & REQUEST OFFERS

You will receive a drawing and a detailed offer within one working day of submitting your request. The frames, modules, and contacts are delivered individually and can be easily assembled (clipped in) on site.

We ask you to enquire directly about customized versions not covered by the standard product.



For information on configuring your connector, please refer to our website: www.odu-mac.com/en/

FOR AUTOMATIC DOCKING

1ST STEP: FRAME SELECTION

Depending upon your requirements, you can choose 4 different frame sizes as a base for automatic docking.

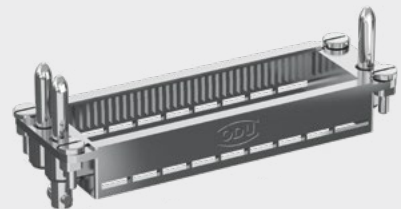

2ND STEP: MODULE SELECTION

Choose from 28 different modules for signals, power, high current, coax, compressed air, fluid, data transmission, fiber optics or PCB termination and assemble your ODU-MAC® Blue-Line individually.

Modules	
Signal	Shielded feedthrough/ high-speed connector
Power	Fiber optic
High current	PCB termination
Coax	Blank modules
Compressed air and fluid	

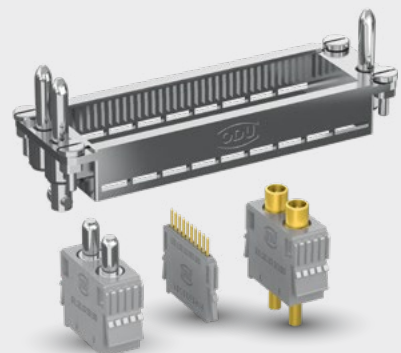

FOR MANUAL MATING

1ST STEP: LOCKING

Select the type of lock in this first step. You have the choice between lever, spindle, and push-pull locking.

Spindle locking Metal/plastic housing	Lever locking Metal housing	Transverse locking Plastic housing	Push-pull locking
---	---------------------------------------	--	--------------------------



2ND STEP: CONNECTOR HOUSING SELECTION

Depending upon the locking system, choose the housing suited to your requirements. The following housings are available:

Spindle locking	Lever locking	Transverse locking	Push-pull locking
Cable hood Metal/plastic housing	Cable hood Metal housing	Cable hood Plastic housing	Cable hood
Cable hood XXL	Cable hood XXL		
	Cable hood wide		



3RD STEP: RECEPTACLE SELECTION

Depending upon the requirements for the receptacle and the selected connector housing, a wide variety of styles is available.

Cable hood	Cable hood XXL	Push-pull locking
Bulkhead housing Metal/plastic housing	Bulkhead housing Metal housing	Receptacle
Surface-mounted housing Metal/plastic housing	Surface-mounted housing Metal housing	
Cable-to-cable hood Metal housing		



The cable hood wide is only compatible with the cable hood wide version of bulkhead and surface-mounted housings.

4TH STEP: MODULE SELECTION

Choose from 28 different modules for signals, power, high current, coax HF signals, compressed air, fluid, data transmission, fiber optics or PCB termination and assemble your ODU-MAC® Blue-Line individually.

Modules
See page 90



ODU-MAC[®] PUSH-LOCK

Maximum packing density in the smallest installation space

We offer a compact, sealed housing with push-pull locking based on the ODU-MAC[®] Blue-Line. In terms of ergonomics, modularity, and user-friendliness, it is in no way inferior to its “big brother” with spindle locking. Seven units can be custom-fitted with hybrid connector configurations offering International Protection class IP67.

With push-pull locking

The compact, sealed ODU-MAC[®] PUSH-LOCK housing with push-pull locking is based on the ODU-MAC[®] Blue-Line. Seven units can be custom-fitted with hybrid connector configurations offering International Protection class IP67. The ergonomic one-handed operation, modular design, and user friendliness of the PUSH-LOCK housing are what set it apart. A total of six optional coding functions and the tried-and-tested push-pull locking principle ensure mating is reliable and secure. This modular rectangular connector benefits from the decades of experience obtained through ODU push-pull circular connectors.

BENEFITS OF THE PUSH-LOCK HOUSING

- Easy and secure **push-pull locking**
- **7 units**
- **Modules:** signal, power, HF signals (coax), compressed air, fluid coupling, data transmission
- **> 5,000** mating cycles
- **IP67**
- **M25** cable outlet
- **Protective cover**

[FURTHER INFORMATION FROM PAGE 42.](#)



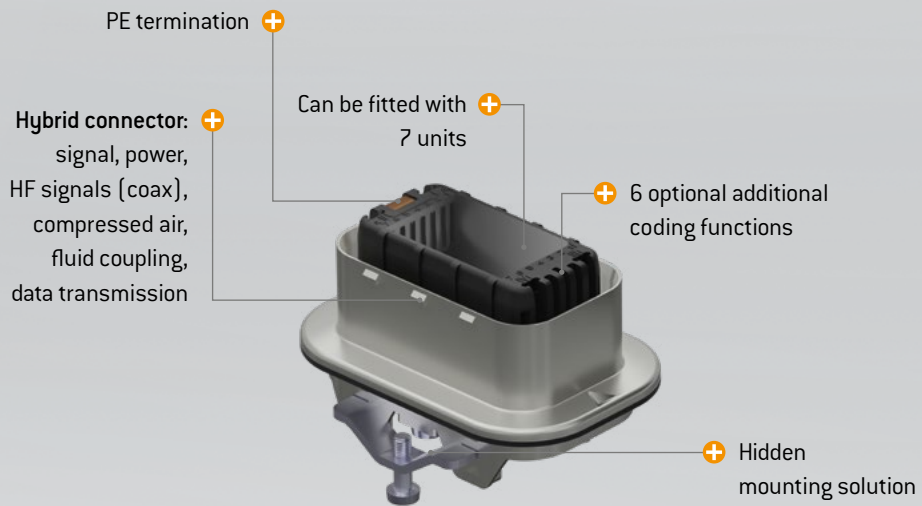

THE BEST CONNECTIONS FOR MANUAL MATING

Housings with spindle locking at a glance.

In the case of spindle locking of the ODU-MAC® Blue-Line, the housings can be equipped with an easy-to-operate precision locking spindle. This spindle enables easy closing and opening of the housing with a single turning movement. The mating and sliding forces overcome in this way ease handling significantly. Only 5 units of space are required for this purpose.

Especially in case of high connection frequency and limited space for locking, the use of precision locking is a preferred option. Depending upon the application scenario, the mechanisms are designed for more than 10,000 locking cycles.

BENEFITS OF SPINDLE LOCKING

- **Low profile** – requires less space for operation than lever locking
- **Easy to use** – one-handed operation
- **Ergonomic design** – elegant spindle knob
- **Tested reliability** – developed for high numbers of locking cycles
- **Fully enclosed** – internal mechanism protects against injury
- **Replaceability** – can be replaced without removing the hood or frame
- **User-friendly** – little force required for operation
- **Precision** – materials, design, and tolerances help to prolong the service life of the complete system



Size	Units ¹	
2	18	
3	26	
4	37	

CABLE HOOD XXL²:

4	37	
---	----	--

FURTHER INFORMATION FROM PAGE [48](#).

¹ 5 units of space required for spindle ² Cable hood XXL only possible in metal version

PLASTIC CABLE HOOD WITH SIDE CABLE OUTLET, PAGE 56

Connector housing for assembly on the cable



METAL CABLE HOOD WITH SIDE CABLE OUTLET, PAGE 48

Connector housing for assembly on the cable



METAL CABLE HOOD XXL WITH SIDE M50 CABLE OUTLET, PAGE 49

Connector housing with expanded assembly space and side M50 cable outlet



FULLY COMPATIBLE

PLASTIC SURFACE-MOUNTED HOUSING, PAGE 58

For surface mounting on your device/wall with spindle locking and two side cable outlets



METAL SURFACE-MOUNTED HOUSING, PAGE 51

For surface mounting on your device/wall with spindle locking and two side cable outlets



PLASTIC BULKHEAD HOUSING, PAGE 57

For mounting on your device with spindle locking



METAL BULKHEAD HOUSING, PAGE 50

For mounting on your device with spindle locking



THE BEST CONNECTIONS FOR MANUAL MATING

ODU-MAC® RAPID housings with spindle locking at a glance

TWICE AS FAST THANKS TO THE HALF-SHELL PRINCIPLE

Our new housing meets all major challenges, including high contact density, flush mounting of the receptacle, and easy adaptability when user requirements change quickly. Special protective covers for both housing parts round out the series.

BENEFITS OF THE RAPID HOUSING

- Up to 50% in time savings through easy assembly and maintenance
- **Flexible cable outlet** – can be adapted to cable or tube assemblies as necessary
- **Optional lattice plates** – enable bundling and strain relief of single strands
- **Half-shell principle** – practical structure as well as fitting and assembly of components in the housing
- **New recessed receptacle version**
- Available for ODU-MAC® White-Line and Blue-Line in size 4 with the proven ODU spindle locking system
- Coding enabled through the guiding pins on the frame; six further coding functions are optional via the spindle module

Size	Units ¹	
4	37	

FURTHER INFORMATION FROM PAGE [52](#).

¹ 5 units of space required for spindle

SPINDLE LOCKING,
PAGE 52

RAPID PLASTIC HOUSING, PAGE 52

Half-shell principle with individually adjustable side cable outlet

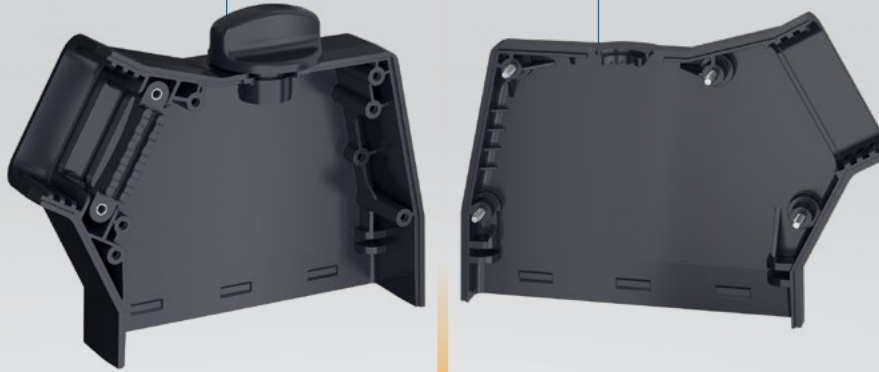

FULLY
COMPATIBLE



PLASTIC RAPID
RECEPTACLE, PAGE 53

For mounting as a recessed
plastic style



RAPID RECEPTACLE, PAGE 53

Direct mounting on the mounting wall

THE BEST CONNECTIONS FOR MANUAL MATING





Housings with transverse locking at a glance.

The efficient and robust plastic housings with transverse locking are available in size 1 to 4 with IP65 as standard.

A space-saving locking type for two-handed safety operation with over 5,000 possible mating cycles, which complements our multi-faceted housing range. It makes manual mating as easy as it is safe.

[FURTHER INFORMATION FROM PAGE 59.](#)

- Locking latch can be changed easily
- Light and robust housing model
- **Space-saving locking**, stackable sidewise
- Two-handed safety operation
- Protection class IP65
- > 5,000 locking cycles

Size	Units	
1	12	
2	18	
3	26	
4	37	

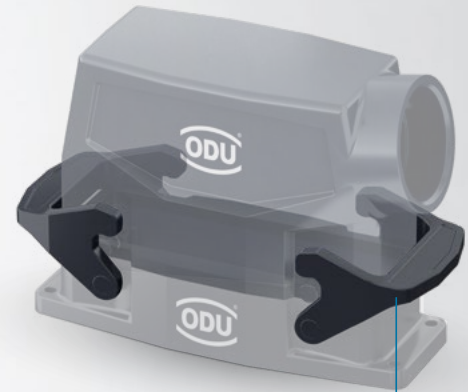

TRANSVERSE LOCKING

**PLASTIC CABLE HOOD
WITH SIDE CABLE OUTLET, PAGE 59**

Connector housing for assembly on the cable



**PLASTIC BULKHEAD
HOUSING, PAGE 60**

For assembly on your device
with transverse locking



**PLASTIC SURFACE-MOUNTED HOUSING,
PAGE 61**

For surface mounting on your device/wall
with transverse locking and two side cable outlets







THE BEST CONNECTIONS FOR MANUAL MATING

Housings with lever locking at a glance.

ODU-MAC® Blue-Line with lever locking offers a wide variety of combination possibilities for manual mating. With the exception of the cable hood wide, all housings can be combined with one another.



Appropriate frames in various sizes are available for use in the standard DIN EN 175301-801:2007 housing with lever. Size 4, for example, can receive up to 37 modules with a module width of 2.4 mm (1 unit), meaning that a total of 37 modules (37 units), or 370 contacts in the case of 10 contacts, can be accommodated. Size 6 of the cable hood wide can even accommodate up to 740 contacts.

Size	Units	
1	12	
2	18	
3	26	
4	37	

CABLE HOOD XXL:

4	37	
---	----	---

CABLE HOOD WIDE:

5	52	
6	74	

FURTHER INFORMATION FROM PAGE [64](#).

METAL CABLE HOOD WIDE WITH TOP CABLE OUTLET, PAGE [68](#)

Connector housing for double frame assembly



METAL CABLE HOOD WIDE WITH SIDE CABLE OUTLET, PAGE [68](#)

Connector housing for double frame assembly



METAL BULKHEAD HOUSING FOR CABLE HOOD WIDE, PAGE [69](#)

For mounting on your device with lever locking (with and without cover)

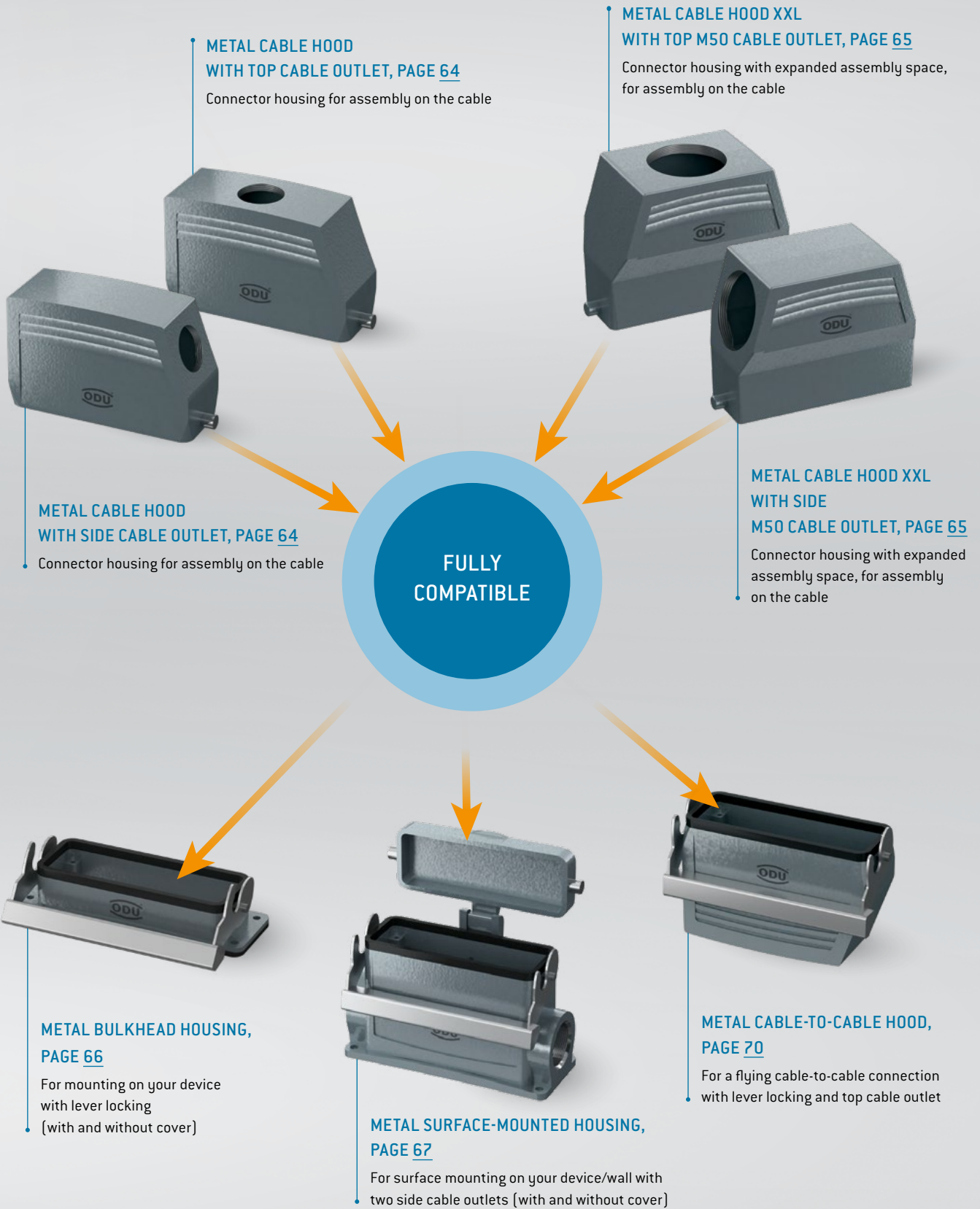

INFORMATION ON THE PLASTIC HOUSING

Plastic housings are primarily used for applications in which a high degree of chemical resistance is required. The glass-fiber reinforced plastic housing reduces the weight and impresses in mechanical robustness.

The plastic housings of ODU-MAC® Blue-Line either use the proven ODU spindle locking technology with a minimum of 10,000 locking cycles, which has excellent ergonomic features, or the customer can choose the efficient transverse locking version instead. An additional grounding of the plastic housing is unnecessary, due to the antistatic, thermoplastic housing.

Hence manual mating becomes as easy as it is safe.



CHEMICAL RESISTANCE

Medium	Material PA6 + GF	
	Resistant	With limited resistance
Ammonia, 10% aqueous solution	•	
Ammonia gas	at room temperature	at 100 °C
Ammonium carbonate	•	
Ammonium chloride	•	
Aniline		•
Asphalt	•	
Beer	•	
Butane gas	•	
Cooking salt, aqueous solution	•	
Copper sulfate, 10% aqueous solution	•	
Cresol solution		•
Cresylic acid		•
Cyclohexane	•	
Diesel	•	
Diluted glycerol	•	
Diluted glycol	•	
Diluted phenol		•
Diethylphthalate	•	
Ethyl alcohol, not denatured	•	
Fruit juices	•	
Glycerol	•	
Heptane	•	
Hexane	•	
Hydrogen sulfide	gaseous	diluted solution
Ink	•	
Isopropyl + ethanol	•	
Isopropyl alcohol	•	
Lactic acid	•	
Linseed oil	•	
Lubricating oil	•	
Mercury	•	
Methyl alcohol, diluted 50%	•	
Mineral oil	•	
Mineral-based oil	•	
Moth balls	•	
Motor oil	•	
n-butanol	•	
Naphthalene	•	
Octane	•	

Medium	Material PA6 + GF	
	Resistant	With limited resistance
Oleic acid	•	
Paraffin oil	•	
Petroleum	•	
Potassium carbonate	•	
Potassium chloride	•	
Potassium iodide	•	
Potassium nitrate	•	
Potassium sulfate	•	
Regular grade petrol	•	
Seawater	•	
Silicone oil	•	> 100 °C
Soap solution	•	
Sodium bicarbonate	•	
Sodium bisulfate, aqueous solution	•	
Sodium carbonate	•	
Sodium chlorate	•	
Sodium chloride	•	
Sodium hydroxide 12.5%	at room temperature	
Sodium nitrate	•	
Sodium nitrite		•
Sodium perborate	•	
Sodium phosphate	•	
Sodium silicate	•	
Sodium sulfate	•	
Sodium sulphide	•	
Sodium thiosulfate	•	
Solution for developing photos	•	
Stearic acid	•	
Stearic acids	•	
Sulfur	•	
Sulfur dioxide		•
Tallow	•	
Tar	•	
Tartaric acid	•	
Transformer oil	•	
Urea, diluted	•	
Urine	•	
Vegetable oil	•	
Water	•	

This list gives a non-exhaustive indication of the chemical resistance offered by the plastic housing. Please contact the ODU team if you have any further questions. They will be happy to assist you.

FRAMES FOR AUTOMATIC DOCKING

Docking frames at a glance

Depending on your requirements, you can choose between 4 different sizes and fit the frame with modules.

There is always a perfect solution with the ODU-MAC® Blue-Line. If your requirements for a connector are not covered by the standard solutions, we also offer special customer-specific solutions.

The ODU-MAC® Blue-Line is designed for 12 to 37 grid units (more on request), meaning that 370 contacts can be installed if the 10-contact module with a module width of 2.4 mm (1 unit) is used.

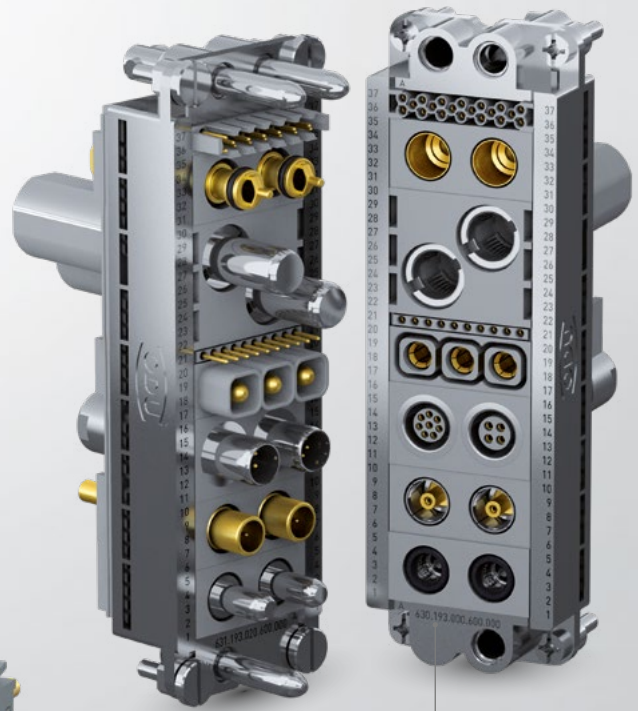

Frame size 4 +
assembled

BENEFITS OF THE ODU-MAC® BLUE-LINE FRAMES

- **Economical**
Quick assembly and removal of the modules in the frame without using tools
- **Flexible**
4 frame sizes (12, 18, 26, 37 units)
28 different modules: signal, power, high current, coax, compressed air, fluid, data transmission, fiber optic or PCB termination
- **Maximum packing density** via the 2.4 mm grid (1 unit)
- **High-performance**
> 10,000 mating cycles
Up to 370 contacts per connector

PIN FRAMES – FLOATING MOUNTING

The frame is suitable for automatic docking.
 Tolerance compensation ± 0.6 mm radial, min. 0.1 mm axial

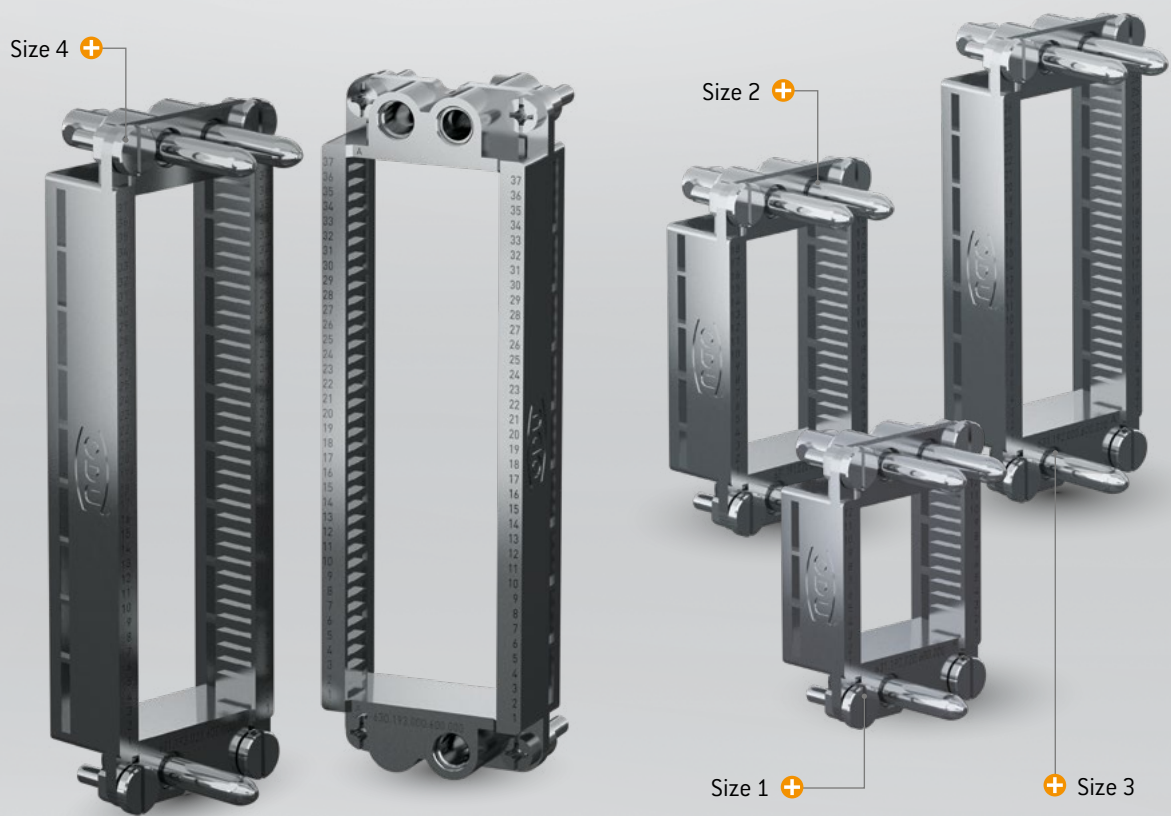

FURTHER INFORMATION FROM PAGE [72](#).

BEST CONNECTIONS – THE CONTACT PRINCIPLE

ODU contacts meet the highest quality standards and enable safe and reliable connections. In order to achieve this, ODU relies on high-performance contact technologies. In the turned contact category, we essentially distinguish between lamella and slotted contacts. The socket pieces differ, but the pins are always the same and always solid.

ODU TURNTAC®

Contacts in slotted version.

The universal ODU TURNTAC® contact system combines the very best contact properties and high quality with economical prices. By means of optimum guidance and assembly in the ODU-MAC® system, the longevity of 10,000 mating cycles and more can be achieved.

The contact principle can even be used in dimensions as tiny as 0.3 mm in diameter. Depending on the version of the slotted contact, the connector system offers two or four contact areas.

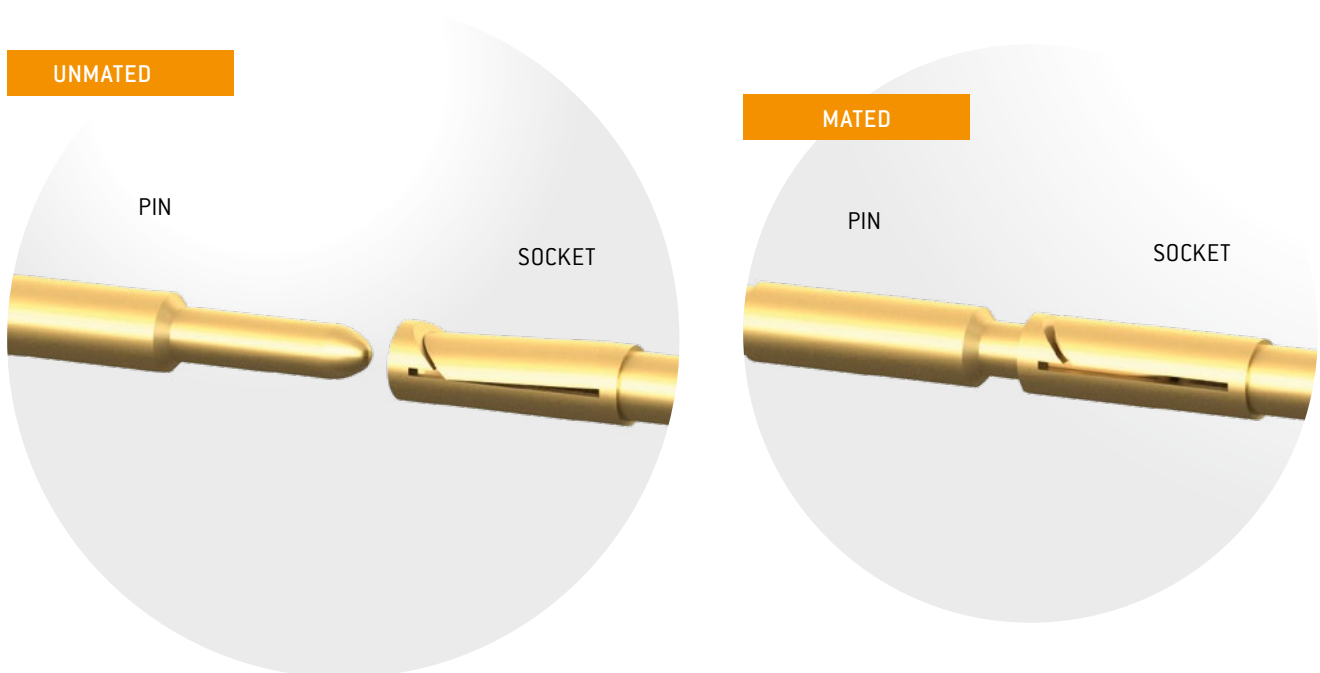

BENEFITS

- > 10,000 mating cycles
- Economical solution
- The smallest dimensions are possible
- Individual contacts on request

Standard contact principle for:	
Signal contact	Ø 0.7–2 mm
Power contact	Ø 3.5 mm
Coax	2 and 4 contacts
Shielded feedthrough	Signal contacts

ODU LAMTAC®

Contacts with lamella technology.

The ODU LAMTAC® consists of a turned carrier in which one or several stamped lamella strips are mounted in a fully automated process. The lamella's individual slats make for a multitude of contact points, thereby guaranteeing a high level of contact safety and ease of connecting. The adapted contact force ensures low mating and demating forces, and a long service life with low wear. The mating cycles here are minimum 10,000.

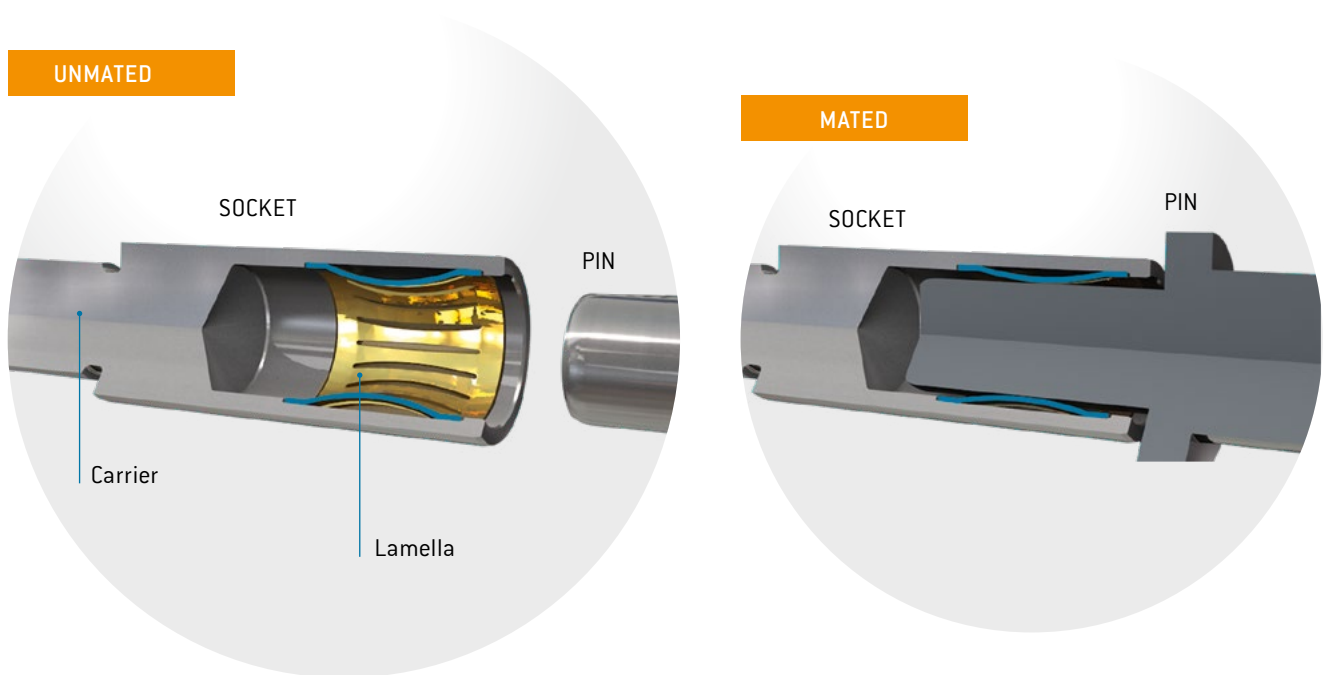

BENEFITS

- > 10,000 mating cycles
- High current-carrying capacity – surge current capacity
- Low contact resistances
- Low mating and demating forces
- High vibration and shock resistance
- Individual contacts on request

Standard contact principle for:	
Power contact	∅ 5–12 mm
Shielded feedthrough	Shielded transmission

CONTACT RETENTION WITH THE CLIP PRINCIPLE (STANDARD)

The graphic below shows how the contact is fixed in the insulator. The contact is pushed from the termination side (rear insertion) into the insulator and locked in by a metal clip (barbed hook) snapping in the insulator. The contacts can be easily removed again from the front at any time with a removal tool.

Compared with permanent connections, crimp technology allows for the replacement of contacts and easy repair. Voltage values can be increased by leaving contact positions free. Contact assembly can be performed independently of the insulator.

Not all modules are equipped with the clip principle, but removal is always possible.

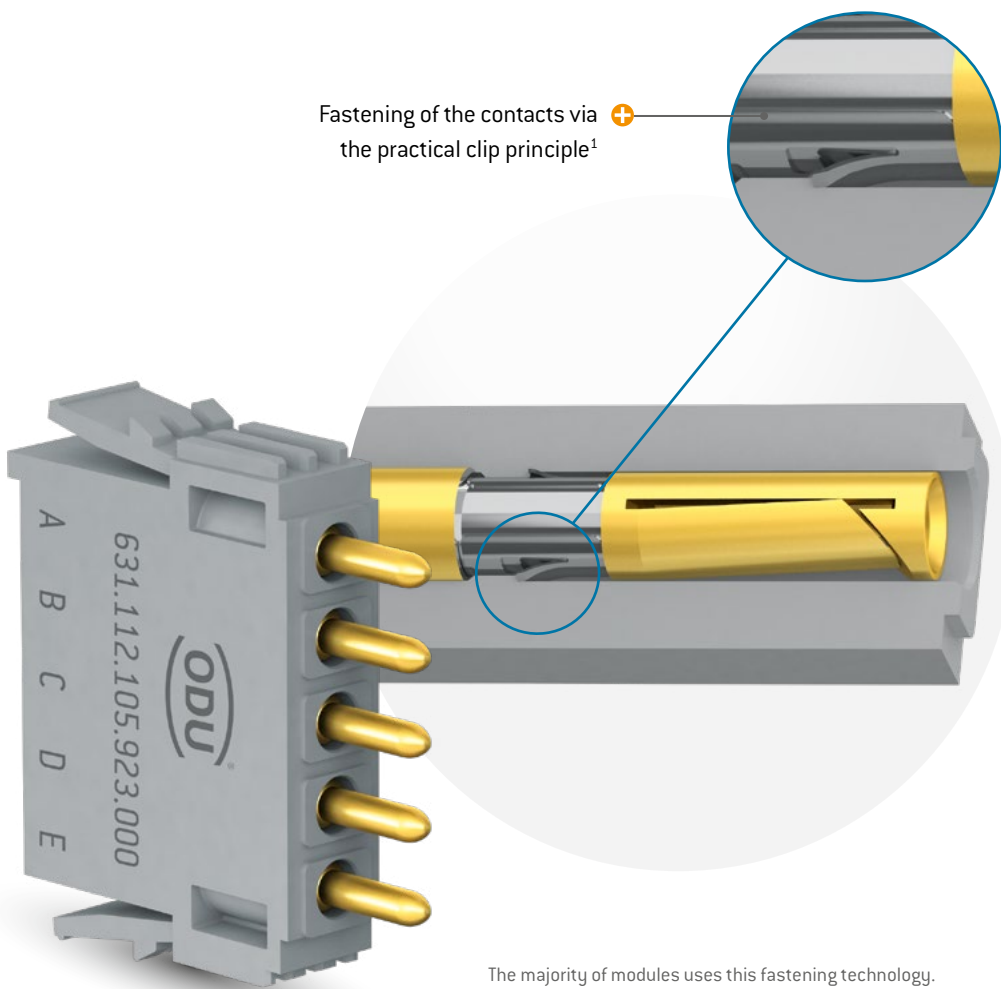

¹ After clipping a new contact in three times, the module must be renewed.

PERFECTLY ASSEMBLED – EASY TO HANDLE

One mechanical and two optical coding functions of the modules simplify the assembly. Modules can be assembled equipped or unequipped (contact assembly is possible at any process step).

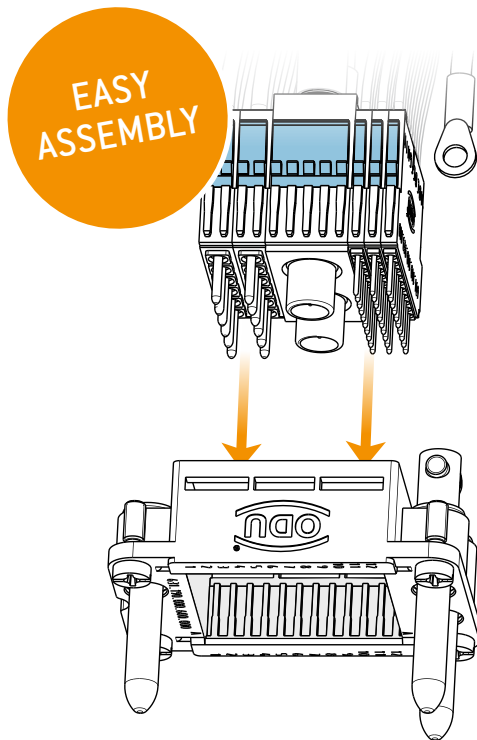

+ Assembly and fastening of the modules using the **clip principle without any tools**

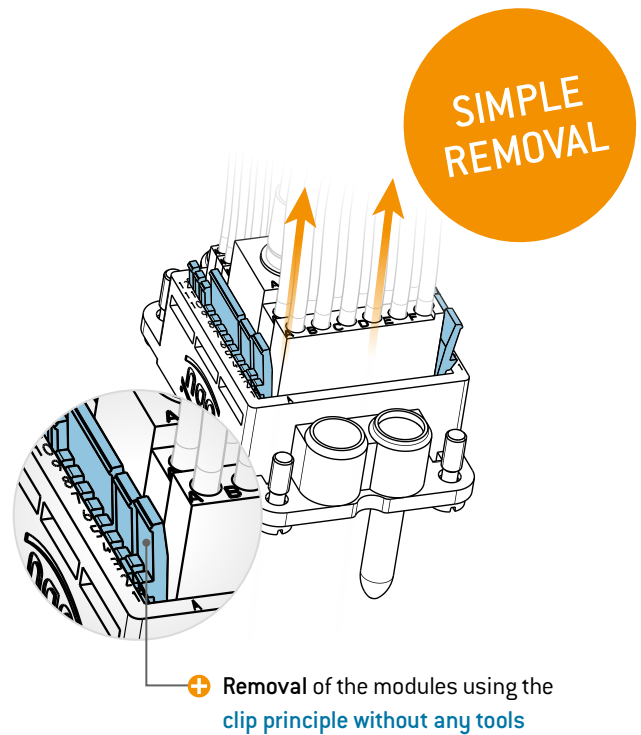

+ Removal of the modules using the **clip principle without any tools**

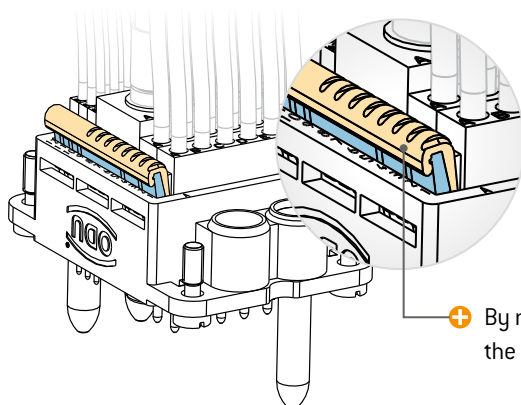

+ By means of **secondary locking**, the module is locked correctly

Please refer to the ODU-MAC® Blue-Line assembly instructions for detailed information. Further information is available in the download area of our website.

PCB TERMINATION MODULES

Easy-to-use termination technology for signal modules via PCB contacting

LONG SERVICE LIFE – ECONOMICAL – EASY TO USE

+ Economical solution
No cables due to the direct PCB termination

+ Convenient exchange
Quick-change system possible for parts subject to wear

+ Long service life
PCB termination modules are manufactured from temperature-resistant PA (solder temperature 260 °C, 30 seconds)

+ Additional grounding
Thanks to grounding pin and socket, available on request

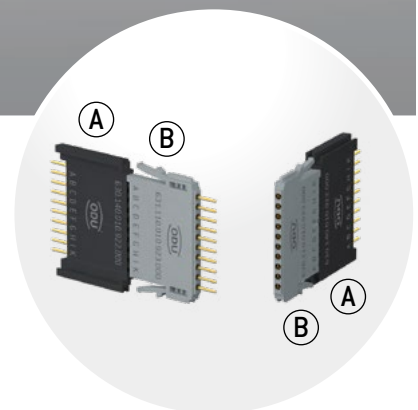
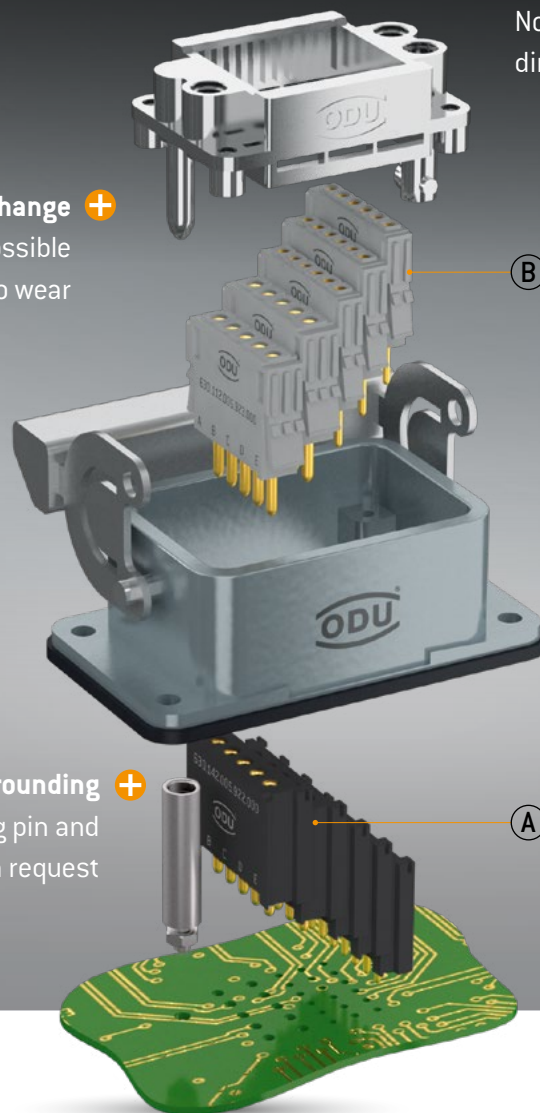

THE BENEFITS OF THE PCB TERMINATION ASSEMBLY

The PCB termination modules (A)¹ are permanently mounted on the board and are connected via an interface to the module (B) that is plugged into the frame. If a module needs to be replaced, then only the module (B) installed in the frame must be replaced. Module (A) that is mounted on the PCB is not affected by this. An effective installation or quick-change function, as the case may be, is thereby achieved.

¹ After clipping a new contact in three times, the module must be renewed.

THE ODU-MAC® BLUE-LINE – FOR THE MOST VARIED APPLICATIONS

MAIN APPLICATION AREAS FOR THE ODU-MAC® BLUE-LINE

- Test and measurement
- Medical
- Industrial
- Special machine construction

ODU-MAC® BLUE-LINE FOR X-RAY MACHINES

The modular ODU-MAC® connector acts as an interface between a mobile X-ray machine and a monitor cart. It transmits high current, data, and signals.



ODU-MAC® BLUE-LINE FOR MEASURING AND TESTING TECHNOLOGY

ODU-MAC® Blue-Line customized power and signal transmission solution for a HIL testing system.



ODU-MAC® BLUE-LINE FOR AUTOMOTIVE TESTING

The ODU-MAC® Blue-Line in a housing with spindle locking provides a reliable interface between the test device and the measured-data receiver.





EASILY CONFIGURE THE ODU-MAC® BLUE-LINE
ONLINE AT: WWW.ODU-MAC.COM/EN/

ODU-MAC®

[Table of contents](#)



MANUAL MATING

ODU-MAC® PUSH-LOCK	42
Spindle locking	44
Metal housing	48
Plastic housing	56
Transverse locking, plastic housing	59
Lever locking, metal housing	64
Frame for housing	72
Accessories	73
Coding options	76

ODU-MAC® PUSH-LOCK



Connector housing for assembly on the cable

PUSH-PULL LOCKING

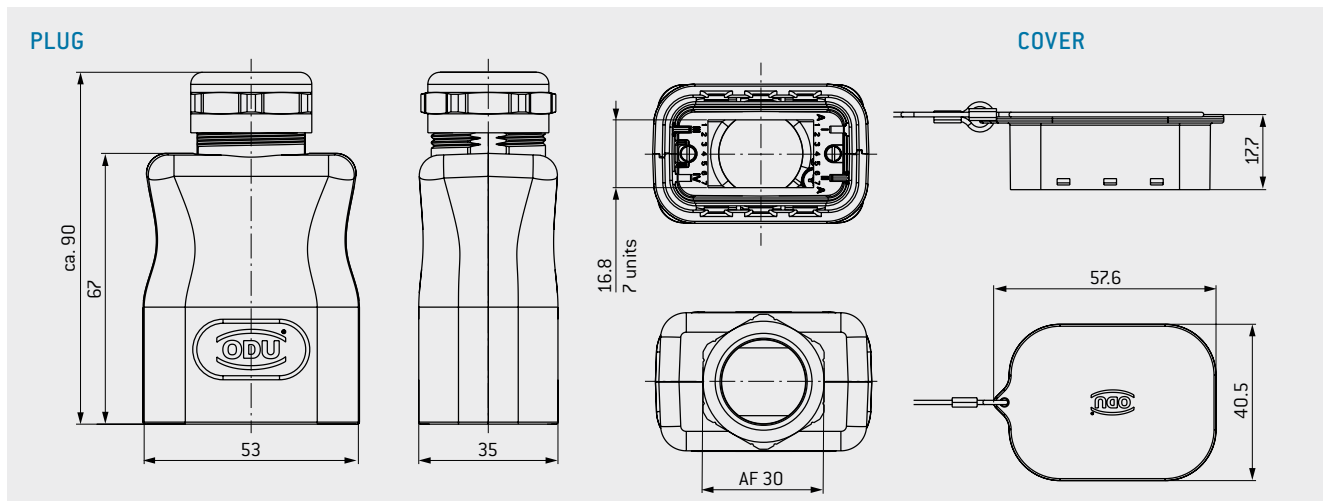

ODU-MAC® PUSH-LOCK	Part number
Cable hood	656.564.012.000.000
Connector coding set	656.564.002.010.000
Connector protective cover	656.564.020.000.000

Assembly set for cable-Ø (has to be ordered separately)	Color	Part number
7 to 10.5	Green	921.000.006.999.001
9 to 13	Red	921.000.006.999.002
14 to 18	Blue	921.000.006.999.003
17 to 20.5	Brown	921.000.006.999.004

TECHNICAL DATA

Color of housing	Black (RAL 9005), White on request
Material housing shell	Lexan PC
Material protective cover	Lexan PC
Number of locking cycles ¹	5,000
Units ²	7
International Protection class ³	IP67
Operating temperature	-40 °C to +125 °C
Cable diameter	7–20.5
Coding	6 more mechanical versions as options



SUITABLE MODULES ARE MARKED.

¹ At maximum mating force for all contacts of 40 N. ² The frame is already permanently integrated and consists of seven units. ³ IEC 60529:2013 (VDE 0470-1:2014)

ODU-MAC® PUSH-LOCK



Receptacle for integration in your device

PUSH-PULL LOCKING

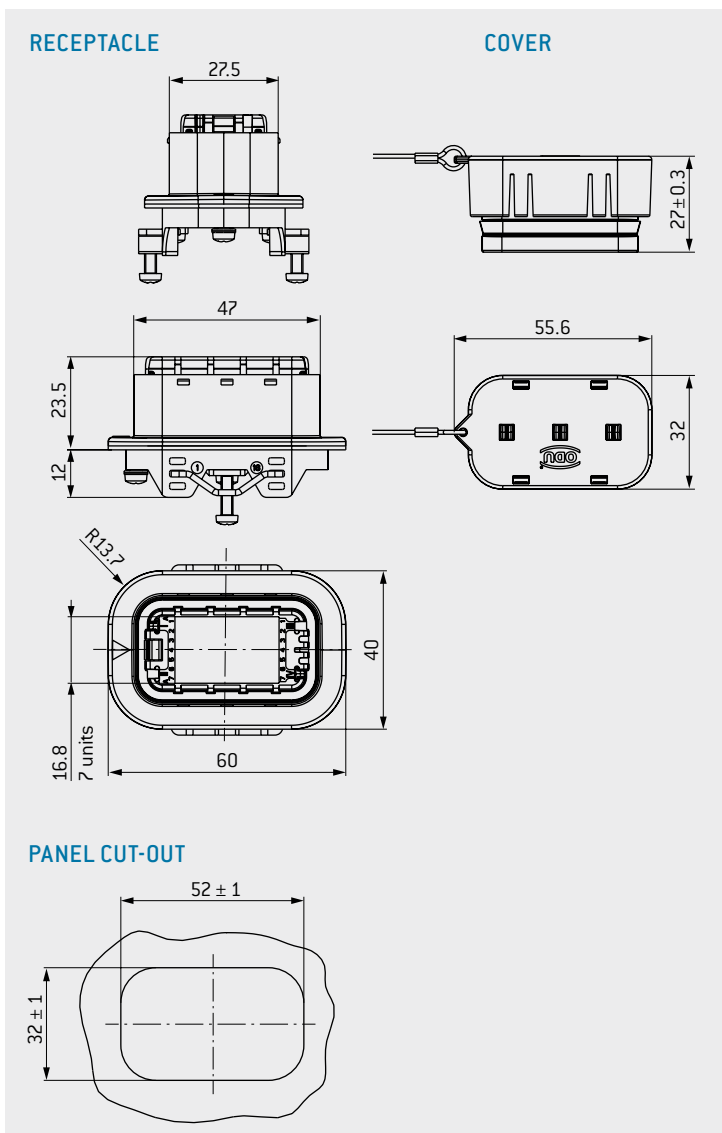
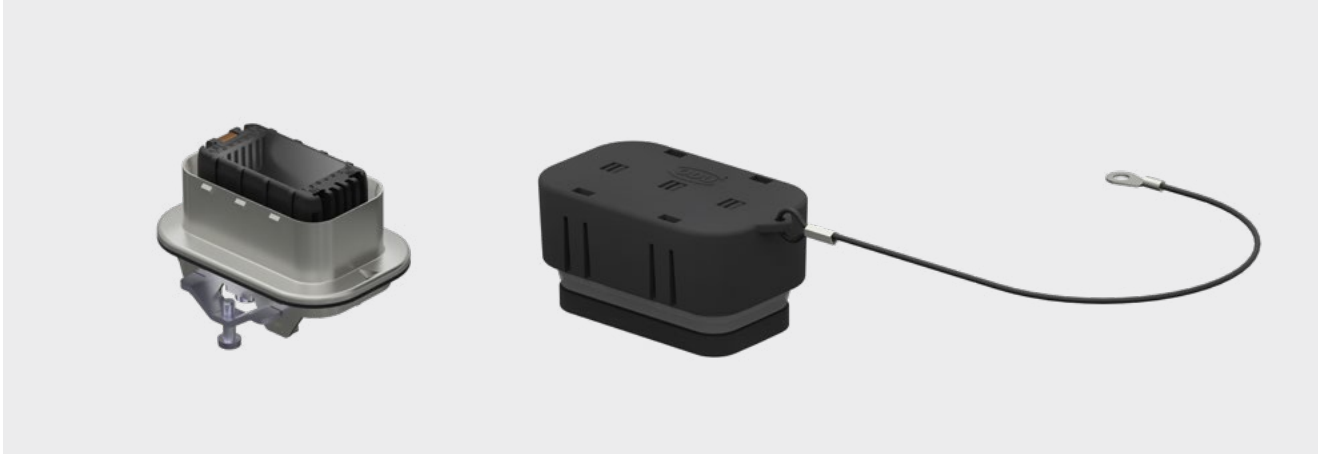

OPTIONAL CODING ELEMENTS

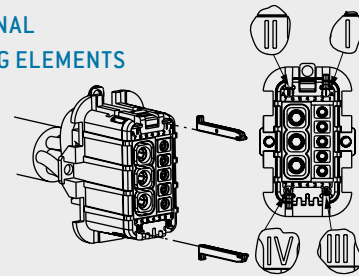

TECHNICAL DATA

Material receptacle	Zn alloy, nickel-plated
Material protective cover	Lexan PC
Number of locking cycles ¹	5,000
Units ²	7
International Protection class ³	IP67
Operating temperature	-40 °C to +125 °C

ODU-MAC® PUSH-LOCK	Part number
Receptacle	656.564.001.000.000
Receptacle coding set	656.564.001.010.000
Receptacle protective cover	656.564.010.000.000

Receptacle coding	
Coding A	I + IV
Coding B	II + III
Coding C	I + II
Coding D	III + IV
Coding E	I + III
Coding F	II + IV

¹ At maximum mating force for all contacts at 40 N. ² The frame is already permanently integrated and consists of seven units. ³ IEC 60529:2013 (VDE 0470-1:2014)

SPINDLE LOCKING (VERSION 1)

Module for installation in ODU-MAC® Blue-Line frame for housing. Quick-action locking system with over 10,000 locking cycles. Easy replacement of the front (replacement spindle set) enables a simple adjustment of the spindle geometry.



VERSION 1: FOR SOCKETS IN BULKHEAD OR SURFACE-MOUNTED HOUSING AND PINS IN CABLE HOOD

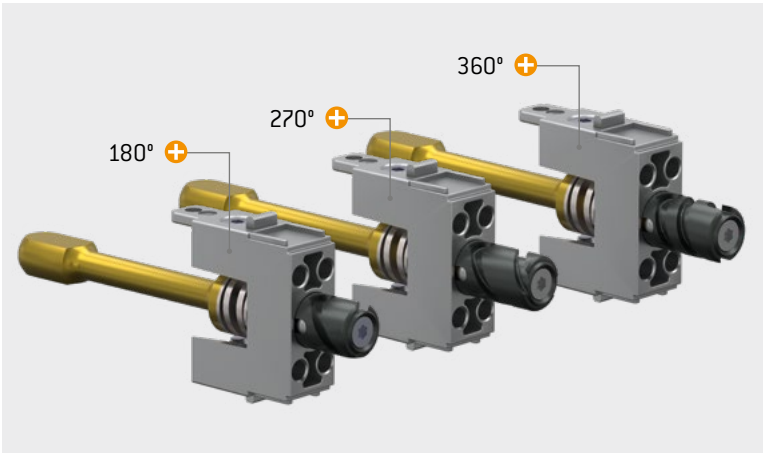

TECHNICAL NOTES

- Min. 10,000 locking cycles
- Space requirement 5 units (5 × 2.4 mm)
- Easy one-hand insertion/connection
- Force benefit by the insertion/connection
- Replaceable spindle screws
- Direct PE contacting (fast-on)

SPINDLE 1 – 12 mm (180°)

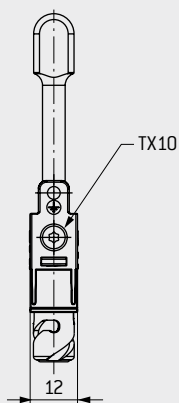
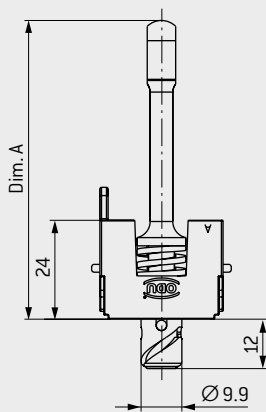

SPINDLE 2 – 16.3 mm (270°)

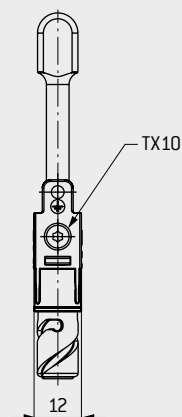
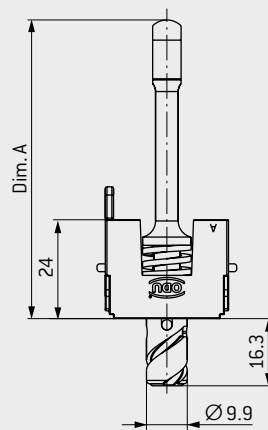

SPINDLE 3 – 16.3 mm (360°)

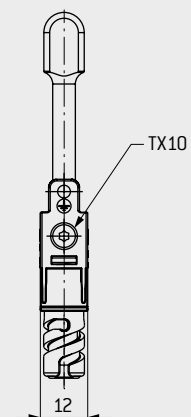
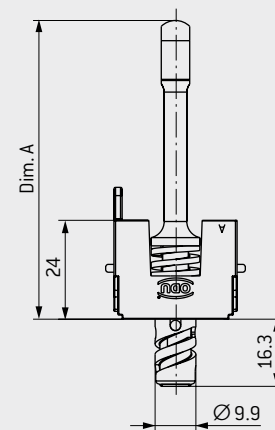



CENTER MODULE SUITABLE FOR SPINDLE 180°, 270°, AND 360°

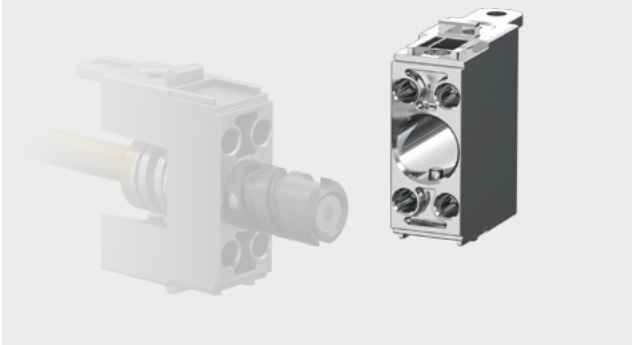

CENTER MODULE FOR SPINDLE LOCKING

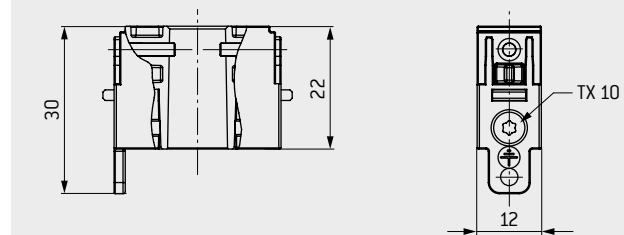

Size	Part number WITHOUT CODING		Part number WITH CODING ¹		Angle of rotation	Dim. A mm
	Center module for bulkhead and surface-mounted housing and cable-to-cable hood	Spindle locking for cable hood	Center module for bulkhead and surface-mounted housing and cable-to-cable hood	Spindle locking for cable hood		
2 (52 mm high)	634.090.001.304.000	635.091.003.200.000	634.090.001.304.010	635.091.003.200.010	180°	46.5
2 (72 mm high)	634.090.001.304.000	635.091.001.200.000	634.090.001.304.010	635.091.001.200.010	180°	66.5
3/4	634.090.001.304.000	635.092.011.200.000	634.090.001.304.010	635.092.011.200.010	270°	72.5
3/4	634.090.001.304.000	635.092.011.200.003	634.090.001.304.010	635.092.011.200.013	360°	72.5
XXL	634.090.001.304.000	635.093.011.200.000	634.090.001.304.010	635.093.011.200.010	270°	90.5
XXL	634.090.001.304.000	635.093.011.200.003	634.090.001.304.010	635.093.011.200.013	360°	90.5

REPLACEMENT SPINDLE SETS 180°, 270°, AND 360°



Part number replacement spindle set	Angle of rotation	Dimension mm
615.090.104.249.000	180°	12
615.090.104.249.004	270°	16.3
615.090.104.249.005	360°	16.3

Depending on the application, a simple adjustment of the spindle geometry is possible using the replacement spindle set.

FOR THE REQUIRED ASSEMBLY AIDS, SEE PAGE [158](#)

¹ Coding pins are included in the standard scope of delivery. For an explanation of spindle coding, see from page [80](#)

SPINDLE LOCKING (VERSION 2)

Module for installation in ODU-MAC® Blue-Line frame for housing. Quick-action locking system with over 10,000 locking cycles. Easy replacement of the front (replacement spindle set) enables a simple adjustment of the spindle geometry.



VERSION 2: FOR PINS IN BULKHEAD OR SURFACE-MOUNTED HOUSING AND SOCKETS IN CABLE HOOD (REVERSED GENDER)

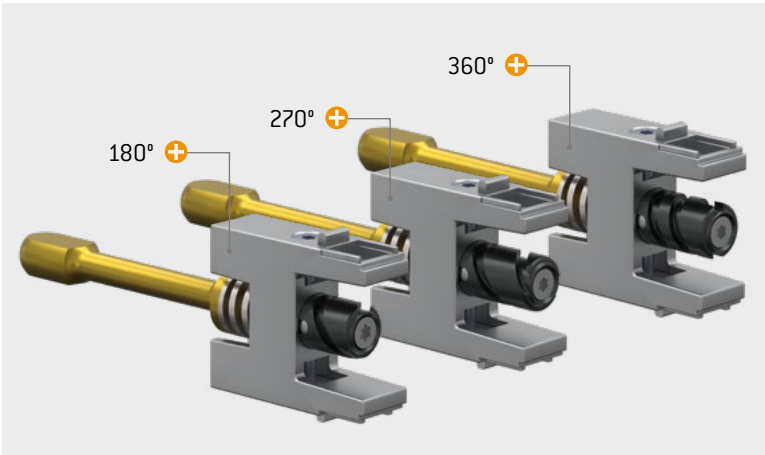

TECHNICAL NOTES

- Min. 10,000 locking cycles
- Space requirement 5 units (5 × 2.4 mm)
- Easy one-hand insertion/connection
- Force benefit by the insertion/connection
- Replaceable spindle screws

SPINDLE 1 – 11.5 mm (180°)

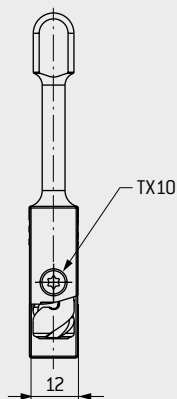
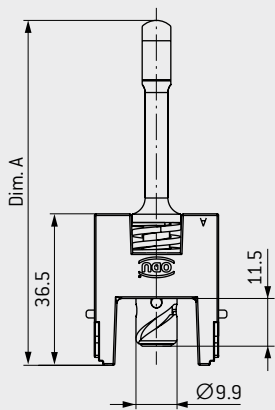

SPINDLE 2 – 15.8 mm (270°)

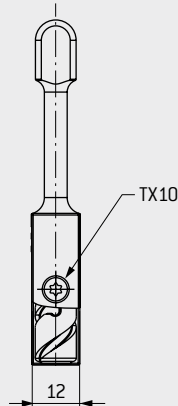
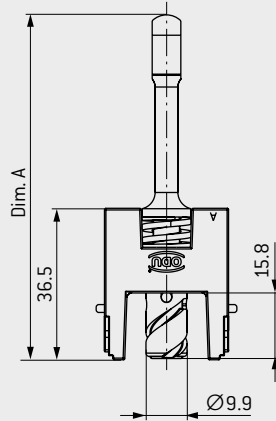

SPINDLE 3 – 15.8 mm (360°)

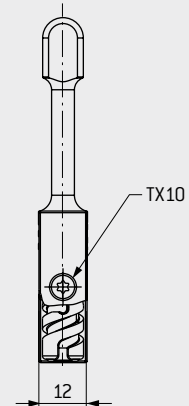
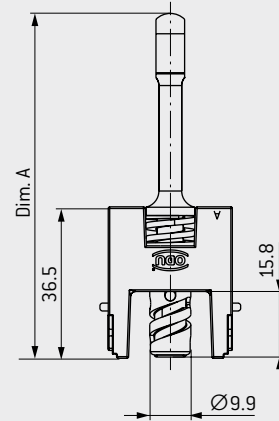



CENTER MODULE SUITABLE FOR SPINDLE 180°, 270°, AND 360°

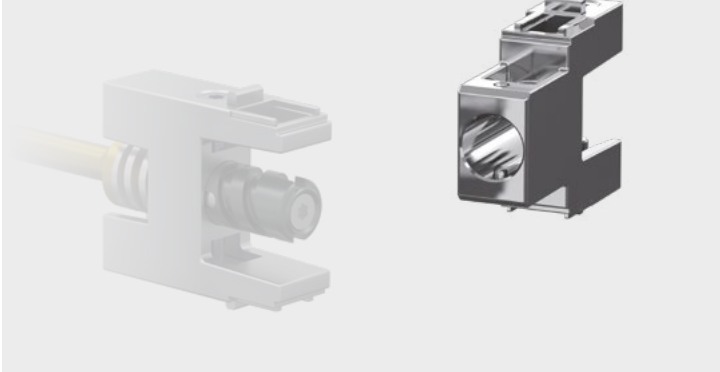

CENTER MODULE FOR SPINDLE LOCKING

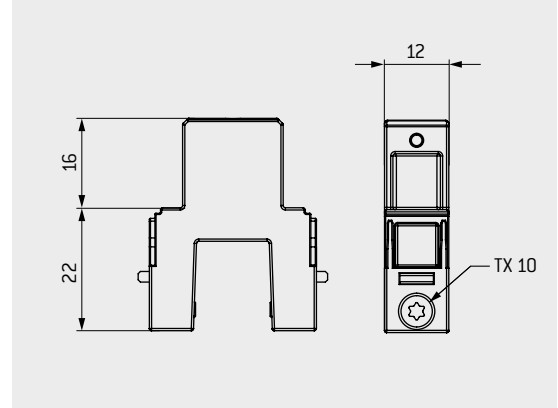

Size	Part number WITHOUT CODING		Angle of rotation	Dim. A mm
	Center module for bulkhead and surface-mounted housing and cable-to-cable hood	Spindle locking for cable hood		
2 (52 mm high)	634.090.002.304.000	635.091.004.200.000	180°	63.5
2 (72 mm high)	634.090.002.304.000	635.091.002.200.000	180°	83
3/4	634.090.002.304.000	635.092.012.200.000	270°	89.1
3/4	634.090.002.304.000	635.092.012.200.003	360°	89.1
XXL	634.090.002.304.000	635.093.012.200.000	270°	107.1
XXL	634.090.002.304.000	635.093.012.200.003	360°	107.1

REPLACEMENT SPINDLE SETS 180°, 270°, AND 360°



Part number replacement spindle set	Angle of rotation	Dimension mm
615.090.104.249.000	180°	12
615.090.104.249.004	270°	16.3
615.090.104.249.005	360°	16.3

Depending on the application, a simple adjustment of the spindle geometry is possible using the replacement spindle set.

FOR THE REQUIRED ASSEMBLY AIDS, SEE PAGE [158](#).

METAL CABLE HOOD



Connector housing for assembly on the cable with side cable outlet

SPINDLE LOCKING

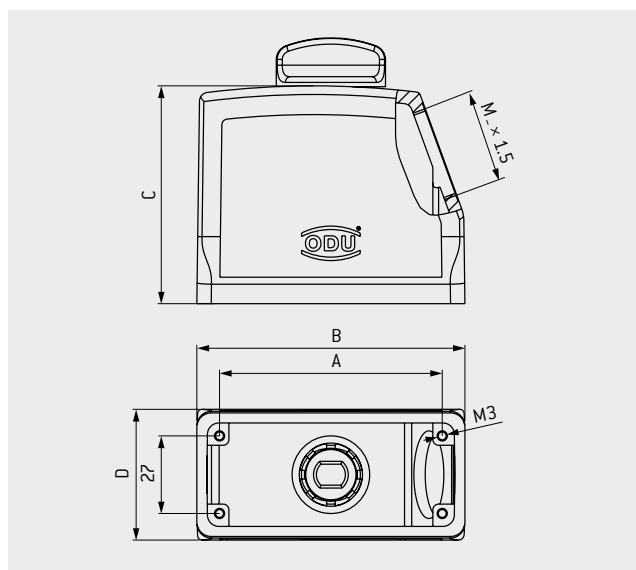

TECHNICAL DATA

Color of housing	Gray (standard, similar to RAL 7001) or White (similar to RAL 9010)
Material	aluminum die casting
International	
Protection class ¹	IP50 or IP65
Operating temperature	-40 °C to +125 °C
Cable clamp	see page 73
Number of locking cycles	see page 44
Adapter	for PG clamp see page 74

Size	IP	Part number A Color of housing gray spindle knob black	Part number B Color of housing white spindle knob white	Part number C Color of housing white spindle knob black	Dim. A mm	Dim. B mm	Dim. C mm	Dim. D mm	Dim. M Cable outlet	Part number Protective cover gray (see page 71)
2	50	613.091.513.644.208	613.091.513.653.203	–	57	73	52	43	M25	491.097613.644.001
	65	613.091.514.644.208	613.091.514.653.203	613.091.514.653.208	57	73	72	43		
3	50	613.091.574.644.008	–	–	57	73	72	43	M32	492.097613.644.001
	65	613.092.514.644.208	613.092.514.653.203	613.092.514.653.208	77.5	93.3	76	45.5		
4	50	613.092.574.644.008	–	–	77.5	93.3	76	45.5	M40	493.097613.644.001
		613.093.514.644.208	613.093.514.653.203	613.093.514.653.208	104	120	76	45.5		
	On request	On request	613.093.515.653.008	104	120	76	45.5			
	65	613.093.574.644.008	–	–	104	120	76	45.5		
		613.093.575.644.008	–	–	104	120	76	45.5	M40	

¹ IEC 60529:2013 (VDE 0470-1:2014) (depends on the cable clamp(s) and spindle knob used)

METAL CABLE HOOD XXL



Connector housing for assembly on the cable with expanded assembly space and side M50 cable outlet

SPINDLE LOCKING



A GRAY MODEL

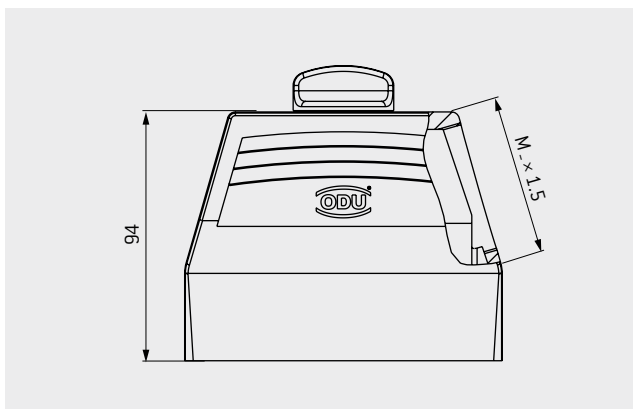

TECHNICAL DATA

Color of housing	Gray (similar to RAL 7001) White on request
Material	aluminum die casting
International	
Protection class ¹	IP50 or IP65
Operating temperature	-40 °C to +125 °C
Cable clamp	see page 73
Number of locking cycles	see page 44

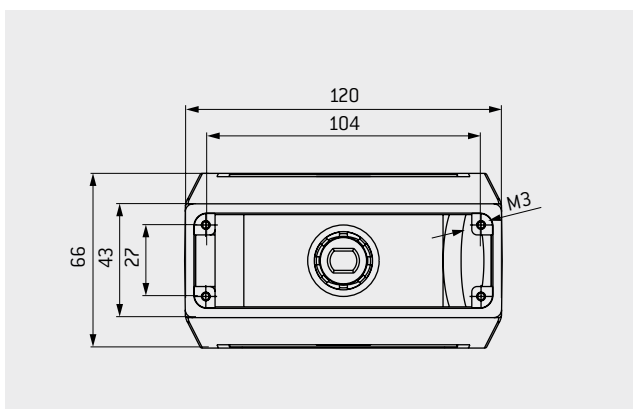

Size	IP	Part number Color of housing gray/spindle knob black	Dim. M Cable outlet	Part number protective cover (see page 71)
4	50	613.093.516.644.208	M50	493.097.613.644.001
4	65	613.093.576.644.008	M50	493.097.613.644.001

¹ IEC 60529:2013 (VDE 0470-1:2014) (depends on the cable clamp(s) and spindle knob used)

METAL BULKHEAD HOUSING



For mounting on your device

SPINDLE LOCKING

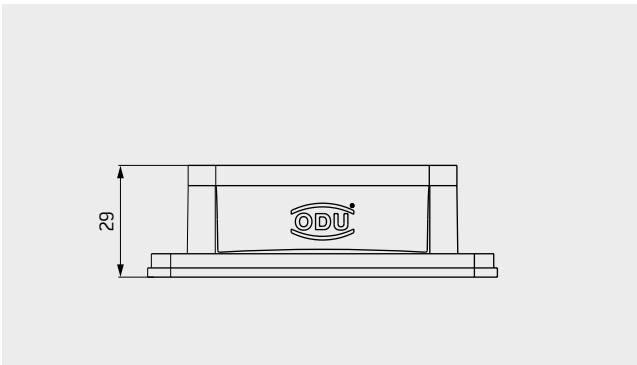

TECHNICAL DATA

Color of housing	Gray (standard, similar to RAL 7001) or White (similar to RAL 9010)
Material	aluminum die casting
International	
Protection class ¹	IP65
Operating temperature	-40 °C to +125 °C (short duration) -40 °C to +85 °C (continuous)
Sealing	NBR; sealing material, FKM on request (to extend the temperature range)

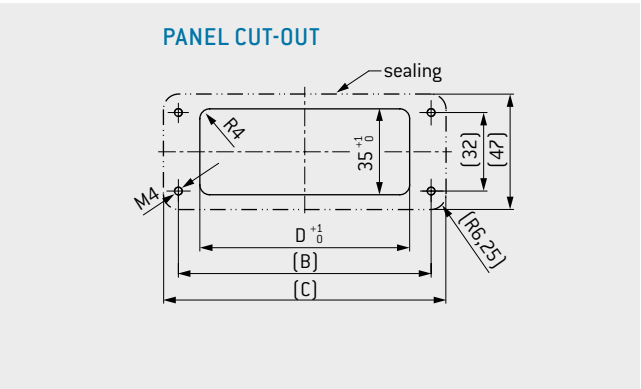
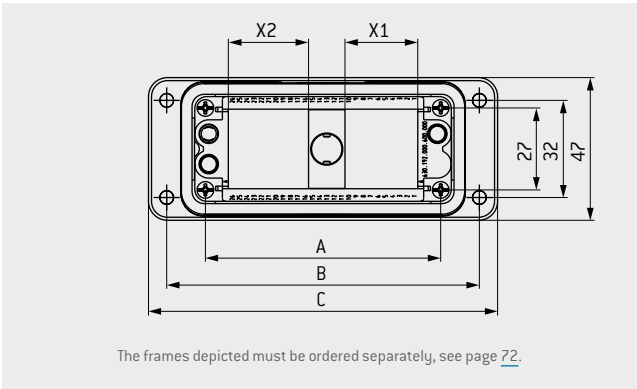

Size	Part number A	Part number B	Dim. A	Dim. B	Dim. C	Dim. D Panel cut-out	X1	X2
	Color of housing gray	Color of housing white	mm	mm	mm	mm	Units × 2.4 mm	Units × 2.4 mm
2	612.091.010.644.000	612.091.010.653.000	57	83	95	65.2	6	7
3	612.092.010.644.000	612.092.010.653.000	77.5	103	115	85.5	10	11
4	612.093.010.644.000	612.093.010.653.000	104	130	143	112.2	16	16

¹ IEC 60529:2013 (VDE 0470-1:2014) [depends on the cable hood with spindle locking used]

METAL SURFACE-MOUNTED HOUSING



For surface mounting on your device/wall with two side cable outlets

SPINDLE LOCKING



A GRAY MODEL (STANDARD)



B WHITE MODEL

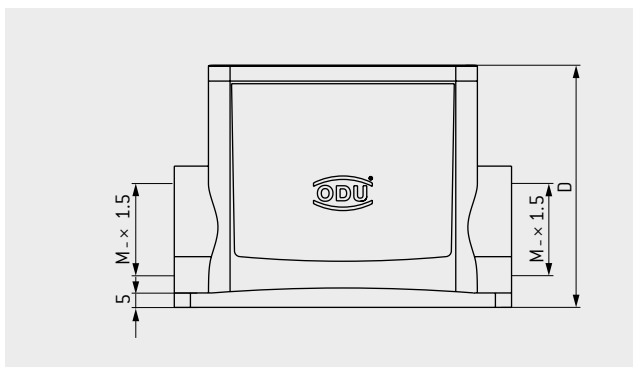

TECHNICAL DATA

Color of housing	Gray (standard, similar to RAL 7001) White on request
Material	aluminum die casting
International	
Protection class ¹	IP65
Operating temperature	–40 °C to +125 °C (short duration) –40 °C to +85 °C (continuous)
Sealing	NBR; sealing material, FKM on request (to extend the temperature range)
Cable clamp	see page 73
Adapter	for PG clamp see page 74

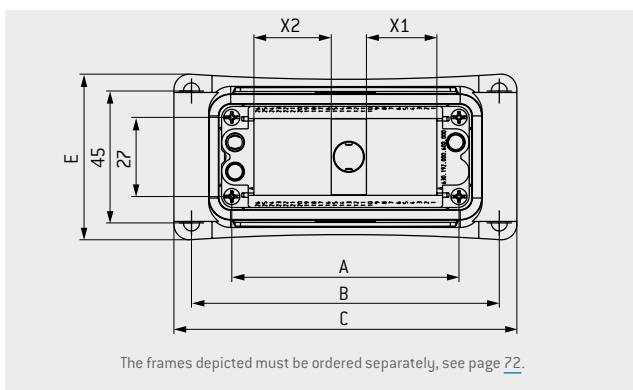

Size	Part number A Color of housing gray	Part number B Color of housing white	Dim. A mm	Dim. B mm	Dim. C mm	Dim. D mm	Dim. E mm	X1 Units × 2.4 mm	X2 Units × 2.4 mm	Dim. M Cable outlet
2	612.091.025.644.102	612.091.025.653.102	57	82	92.5	74	55.5	6	7	M32
3	612.092.025.644.102	612.092.025.653.102	77.5	105	117	84	56.5	10	11	M32
4	612.093.025.644.102	612.093.025.653.102	104	132	144	84	57.5	16	16	M32
	612.093.026.644.000	–								M40

¹ IEC 60529:2013 (VDE 0470-1:2014) (depends on the cable clamp(s) and cable hood with spindle locking used)

ODU-MAC[®] RAPID PLASTIC HOUSING



Half-shell principle with individually adjustable side cable outlet

SPINDLE LOCKING

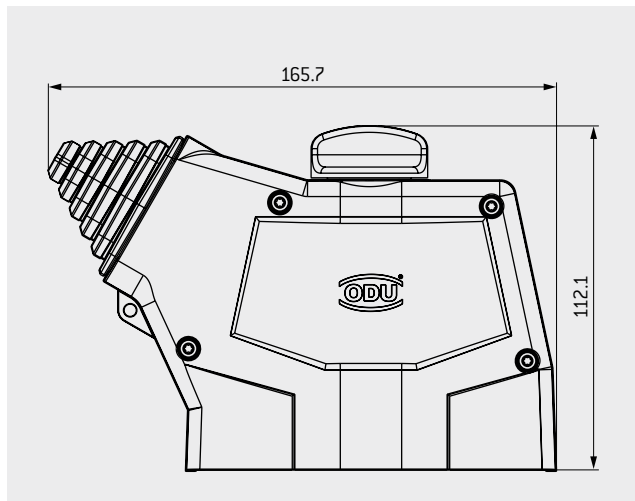

TECHNICAL DATA

Color of housing	Black (RAL 9005), White on request
Material	plastic Lexan PC, UL 94-V0
International	
Protection class	IP4X
Operating temperature	-40 °C to +125 °C
Grommet	silicone (RAL 7035), UL 94-V0
Number of locking cycles	see from page 44
Coding	spindle coding from page 80 (6 options)

Size	Part number	Description	Cable outlet □	Part number protective cover [see page 54]
4	656.563.012.008.000	RAPID housing	Max. 32 × 42 mm	656.563.012.018.000
4	635.093.011.200.000	Spindle locking 270° without coding		
4	635.093.011.200.003	Spindle locking 360° without coding		
4	635.093.011.200.010	Spindle locking 270° with coding		
4	635.093.011.200.013	Spindle locking 360° with coding		
RAPID	631.193.000.600.001	Housing frame, pin side		

ODU-MAC[®] RAPID RECEPTACLE VERSIONS



For mounting on your device or as a recessed plastic style

SPINDLE LOCKING



A RECESSED ASSEMBLY OF THE SOCKET FRAME IN ASSEMBLY WALL



B DIRECT ASSEMBLY OF THE SOCKET FRAME ON ASSEMBLY WALL

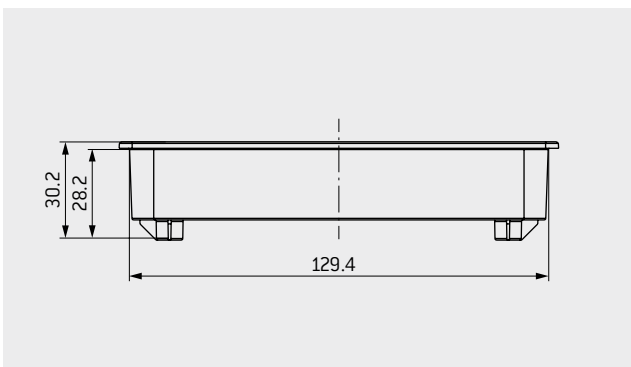

TECHNICAL DATA

Color of housing (recessed style)	Black (RAL 9005), White on request
Material	plastic Lexan PC, UL 94-V0
International	
Protection class	IP4X
Operating temperature	-40 °C to +125 °C

PANEL CUT-OUT A: RECESSED STYLE



PANEL CUT-OUT B: DIRECT ASSEMBLY

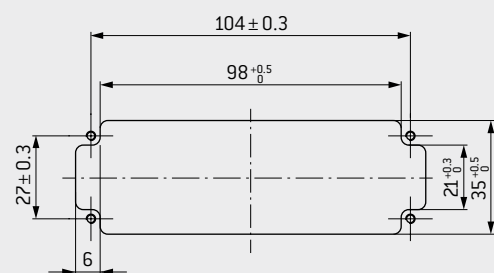

Size	Part number	Description	Part number protective cover [see page 54]
4	656.563.001.008.000	Recessed-style receptacle, version A	656.563.011.018.000
4	630.193.000.600.000	Housing frame, socket side (both versions)	
4	634.090.001.304.000	Center module for spindle without coding	
4	634.090.001.304.010	Center module for spindle with coding	

PLASTIC PROTECTIVE COVER



For ODU-MAC® RAPID housing and recessed-style receptacle

HOUSING **A**

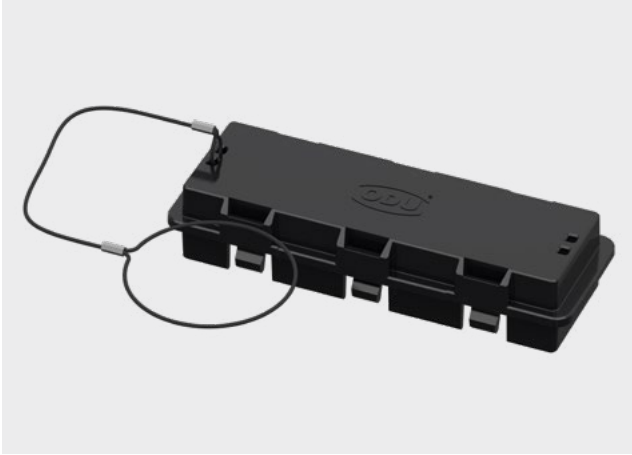

RECESSED-STYLE RECEPTACLE **B**

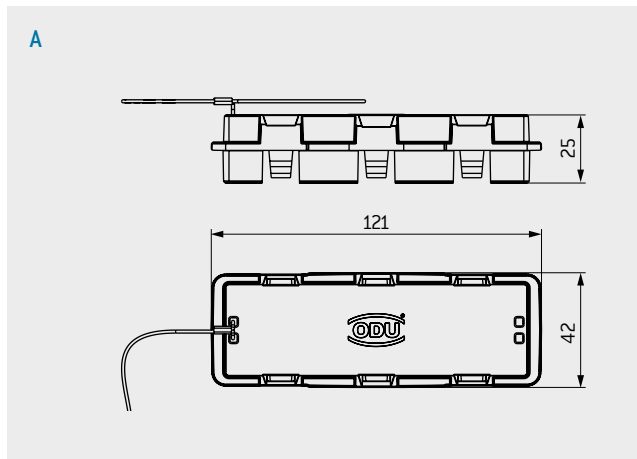
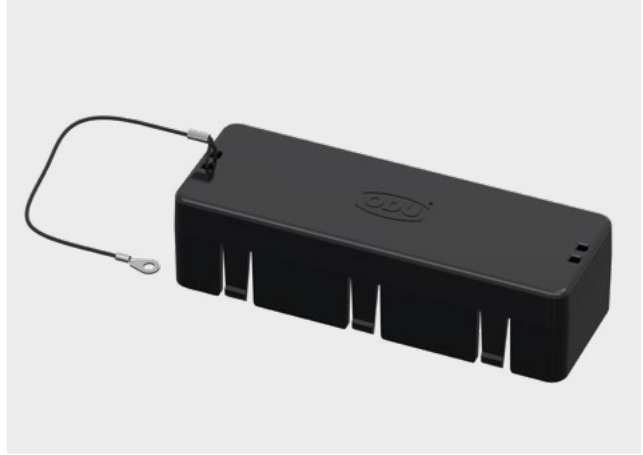

TECHNICAL DATA

Color of housing	Black (RAL 9005), White on request
Material	plastic Lexan PC, UL 94-V0
International	
Protection class	IP4X
Operating temperature	-40 °C to +125 °C

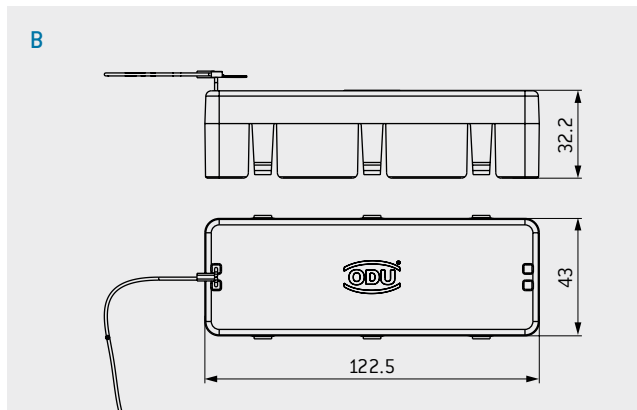

Size	Part number A protective cover for housing	Part number B protective cover for re- cessed-style receptacle	Lanyard length A mm	Lanyard length B mm
4	656.563.012.018.000	656.563.011.018.000	300	150

STRAIN-RELIEF SET



For ODU-MAC® RAPID housing, the option for bundling and additional strain relief of single strands

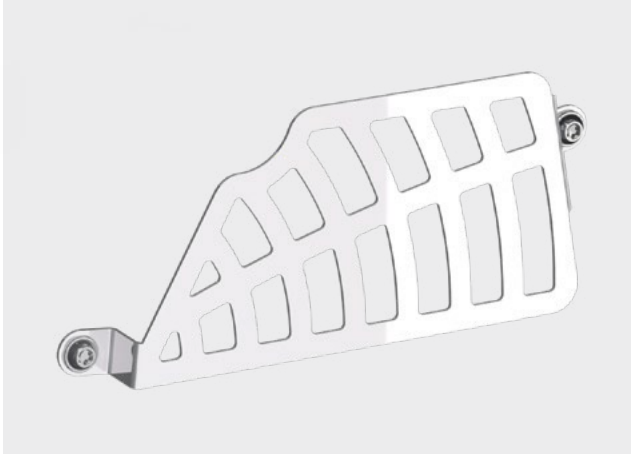

Optional lattice plates for strand bundling can also be retrofitted.

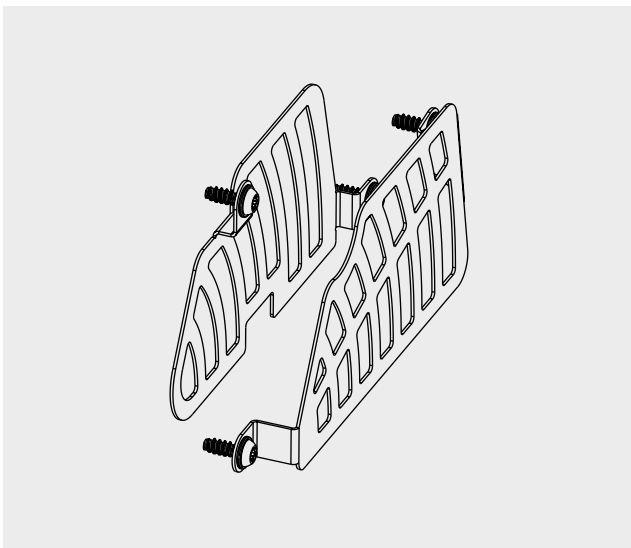

TECHNICAL DATA

Material stainless steel
Operating temperature $-40\text{ }^{\circ}\text{C}$ to $+125\text{ }^{\circ}\text{C}$

Size	Part number	Included accessories
4	656.563.002.050.000	2 × strain-relief plate including fastening screws 4 × S3 × 13.5 TX10

PLASTIC CABLE HOOD



Plastic cable hood for assembly on the cable with side cable outlet

SPINDLE LOCKING

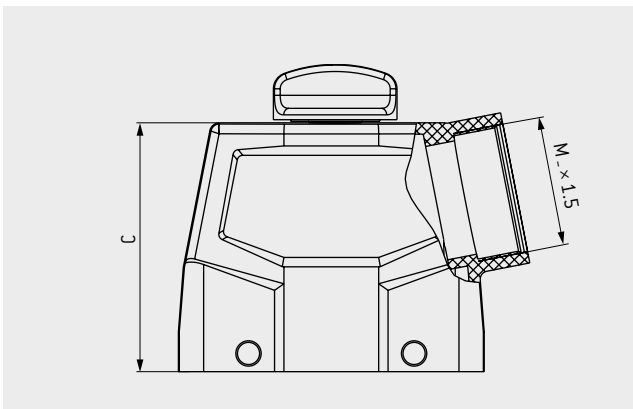

TECHNICAL DATA

Color of housing	Black (RAL 9005)
Material	plastic PA6 GF, UL 94-V0
International	
Protection class ¹	IP50 IP65 on request
Operating temperature	-40 °C to +125 °C
Cable clamp	see page 73
Number of locking cycles	see from page 44

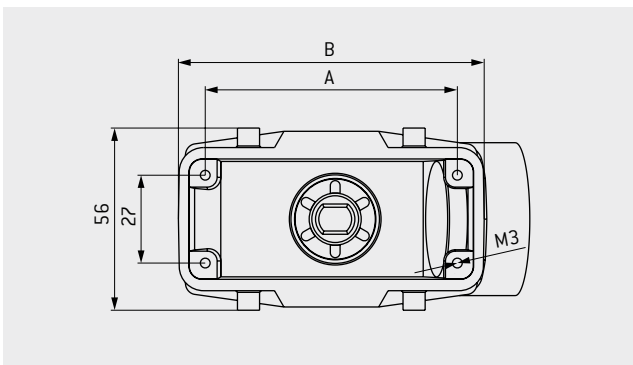

Size	Part number	Dim. A	Dim. B	Dim. C	Dim. M	Part number protective cover
		mm	mm	mm	Cable outlet	(see page 63)
2	613.091.514.908.308	57	74	72.5	M32	491.097.613.908.001
3	613.092.514.908.308	77.5	94	76.5	M40	492.097.613.908.001
4	613.093.514.908.308	104	121	76.5	M40	493.097.613.908.001

FOR A REDUCTION FROM M40 TO M32, SEE PAGE 73

¹ IEC 60529:2013 (VDE 0470-1:2014) (depends on the cable clamp(s) and spindle knob used)

PLASTIC BULKHEAD HOUSING



For mounting on your device with spindle locking

SPINDLE LOCKING

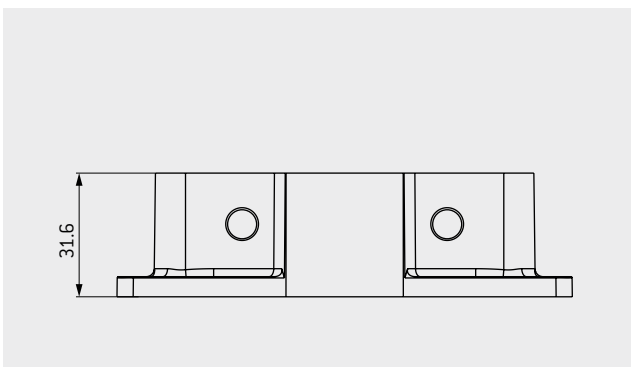

TECHNICAL DATA

Color of housing	Black (RAL 9005)
Material	plastic PA6 GF, UL 94-V0
International	
Protection class ¹	IP50 IP65 on request
Operating temperature	-40 °C to +125 °C
Sealing	NBR; sealing material

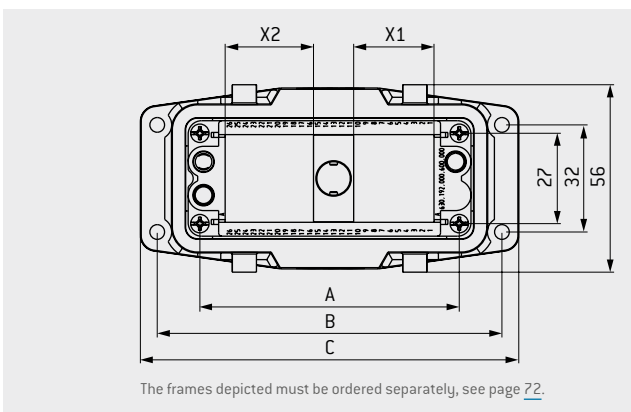

PANEL CUT-OUT

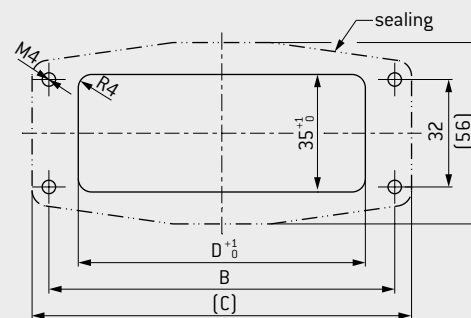

Size	Part number	Dim. A mm	Dim. B mm	Dim. C mm	Dim. D Panel cut-out mm	X1 Units × 2.4 mm	X2 Units × 2.4 mm	Part number protective cover (see page 62)
2	612.091.010.908.000	57	83	93	67	6	7	491.097.612.908.001
3	612.092.010.908.000	77.5	103	114	87	10	11	492.097.612.908.001
4	612.093.010.908.000	104	130	140	114	16	16	493.097.612.908.001

¹ IEC 60529:2013 (VDE 0470-1:2014) (depends on the cable hood with spindle locking used)

PLASTIC SURFACE-MOUNTED HOUSING



For surface mounting on your device/wall with two side cable outlets

SPINDLE LOCKING

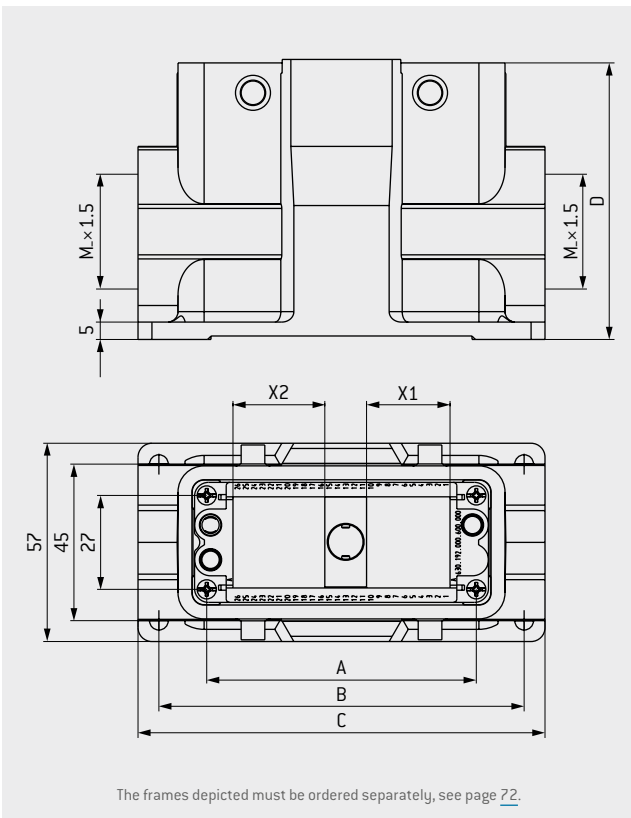

TECHNICAL DATA

Color of housing	Black (RAL 9005)
Material	Plastic PA6 GF, UL 94-V0
International	
Protection class ¹	IP50 IP65 on request
Operating temperature	-40 °C to +125 °C
Sealing	NBR; sealing material
Cable clamp	see page 73

Size	Part number	Dim. A	Dim. B	Dim. C	Dim. D	X1	X2	Dim. M	Part number protective cover
		mm	mm	mm	mm	Units × 2.4 mm	Units × 2.4 mm	Cable outlet	[see page 62]
2	612.091.020.908.000	57	82	94	81.5	6	7	M32	491.097.612.908.001
3	612.092.020.908.000	77.5	105	117	81.5	10	11	M40	492.097.612.908.001
4	612.093.020.908.000	104	132	144	81.5	16	16	M40	493.097.612.908.001

FOR A REDUCTION FROM M40 TO M32, SEE PAGE 73

¹ IEC 60529:2013 (VDE 0470-1:2014) [depends on the cable clamp(s) and cable hood with spindle locking used]

PLASTIC CABLE HOOD



Plastic cable hood for assembly on the cable with side cable outlet

TRANSVERSE LOCKING

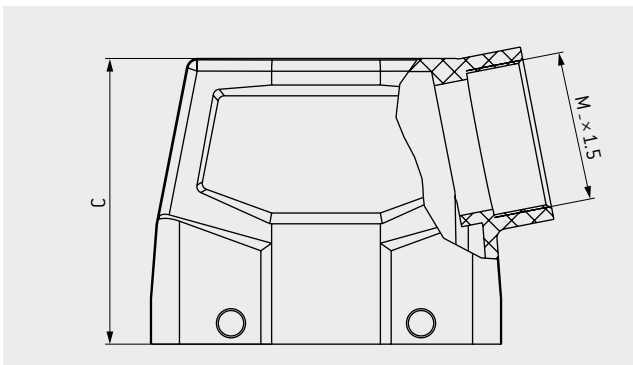

TECHNICAL DATA

Color of housing	Black (RAL 9005)
Material	plastic PA6 GF, UL 94-V0
International	
Protection class ¹	IP65
Operating temperature	-40 °C to +125 °C
Cable clamp	see page 73
Number of locking cycles	5,000

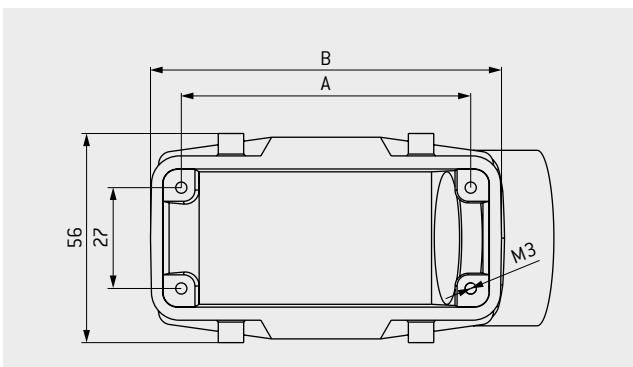

Size	Part number	Dim. A	Dim. B	Dim. C	Dim. M	Part number protective cover
		mm	mm	mm	Cable outlet	[see page 63]
1	490.420.650.908.000	44	54	72.5	M32	490.097.613.908.001
2	491.420.650.908.000	57	74	72.5	M32	491.097.613.908.001
3	492.420.650.908.000	77.5	94	76.5	M40	492.097.613.908.001
4	493.420.650.908.000	104	121	76.5	M40	493.097.613.908.001

FOR A REDUCTION FROM M40 TO M32 AND FROM M32 TO M25, SEE PAGE 73

¹ IEC 60529:2013 (VDE 0470-1:2014) [depends on the cable clamp(s) used]

PLASTIC BULKHEAD HOUSING



For assembly on your device with transverse locking

TRANSVERSE LOCKING

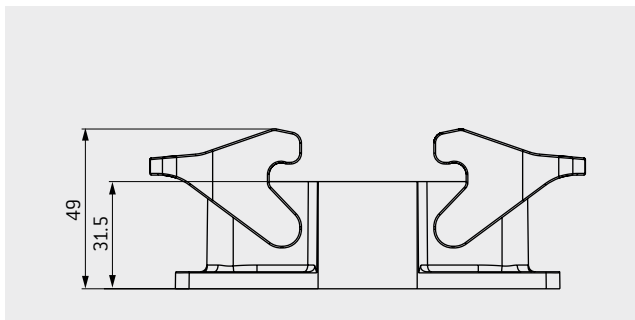

TECHNICAL DATA

Color of housing	Black (RAL 9005)
Material	plastic PA6 GF, UL 94-V0
International	
Protection class ¹	IP65
Operating temperature	-40 °C to +125 °C
Sealing	NBR; sealing material

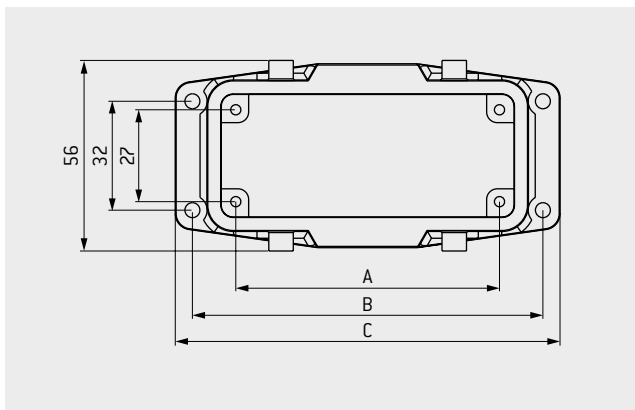

PANEL CUT-OUT

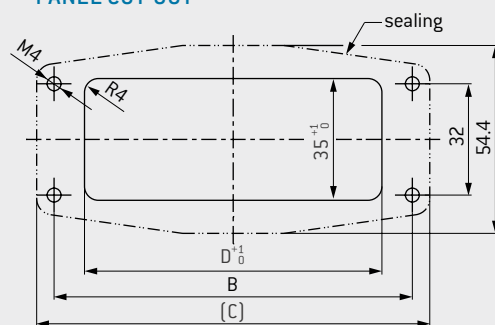

Size	Part number	Dim. A mm	Dim. B mm	Dim. C mm	Dim. D Panel cut-out mm	Part number protective cover [see page 62]
1	490.120.600.908.000	44	70	80	53	490.097.612.908.000
2	491.120.600.908.000	57	83	93.2	66	491.097.612.908.000
3	492.120.600.908.000	77.5	103	113	86	492.097.612.908.000
4	493.120.600.908.000	104	130	140	113	493.097.612.908.000

¹ IEC 60529:2013 (VDE 0470-1:2014) [depends on the cable hood used]

PLASTIC SURFACE-MOUNTED HOUSING



For surface mounting on your device/wall with two side cable outlets

TRANSVERSE LOCKING

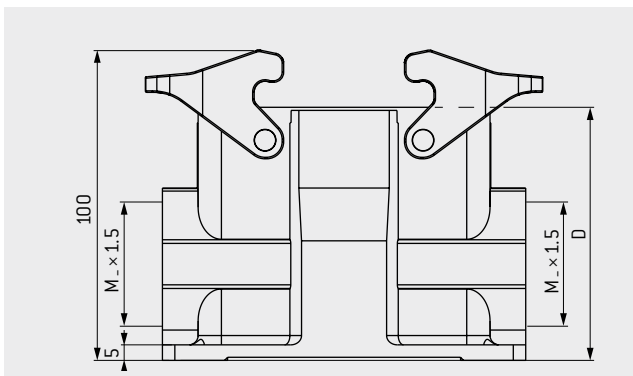

TECHNICAL DATA

Color of housing	Black (RAL 9005)
Material	plastic PA6 GF, UL 94-V0
International	
Protection class ¹	IP65
Operating temperature	-40 °C to +125 °C
Sealing	NBR; sealing material
Cable clamp	see page 73

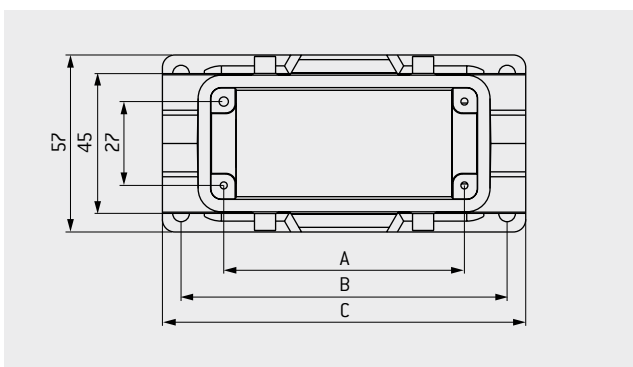

Size	Part number	Dim. A	Dim. B	Dim. C	Dim. D	Dim. M	Part number protective cover (see page 62)
		mm	mm	mm	mm	Cable outlet	
1	490.120.650.908.000	44	70	82	74.7	M32	490.097.612.908.000
2	491.120.650.908.000	57	82	94	81.5	M32	491.097.612.908.000
3	492.120.650.908.000	77.5	105	117	81.5	M40	492.097.612.908.000
4	493.120.650.908.000	104	132	144	81.5	M40	493.097.612.908.000

FOR A REDUCTION FROM M40 TO M32 AND FROM M32 TO M25, SEE PAGE 73

¹ IEC 60529:2013 (VDE 0470-1:2014) (depends on the cable clamp(s) and cable hood used)

PLASTIC PROTECTIVE COVER



For bulkhead and surface-mounted housing with lanyard

SPINDLE LOCKING

A



TRANSVERSE LOCKING

B



SPINDLE AND TRANSVERSE LOCKING

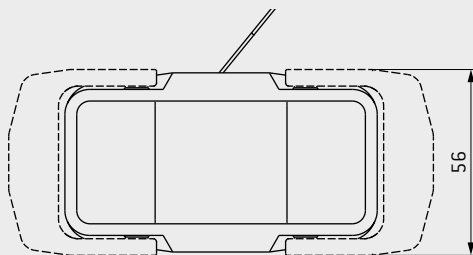

TECHNICAL DATA

Color of housing	Black (RAL 9005)
Material	plastic PA6 GF, UL 94-V0
International	
Protection class ¹	IP65
Operating temperature	-40 °C to +125 °C

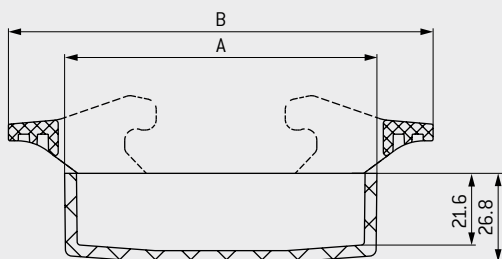

Dotted line and dimension B only applies to spindle locking

Size	Part number A	Part number B	Dim. A	Dim. B
	Protective cover for spindle locking	Protective cover for transverse locking	mm	mm
1	—	490.097.612.908.000	61	95
2	491.097.612.908.001	491.097.612.908.000	74	108
3	492.097.612.908.001	492.097.612.908.000	94	128
4	493.097.612.908.001	493.097.612.908.000	121	155

¹ IEC 60529:2013 (VDE 0470-1:2014)

PLASTIC PROTECTIVE COVER



For cable hood with lanyard

SPINDLE AND TRANSVERSE LOCKING



SPINDLE AND TRANSVERSE LOCKING

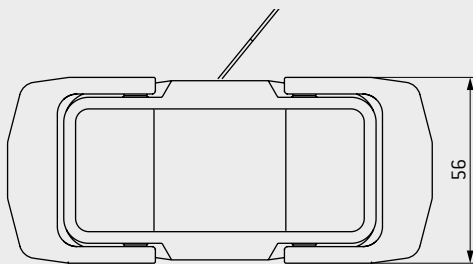

TECHNICAL DATA

Color of housing	Black (RAL 9005)
Material	plastic PA6 GF, UL 94-V0
International	
Protection class ¹	IP65
Operating temperature	-40 °C to +125 °C
Sealing	NBR; sealing material
Locking	via the transverse locking included in the delivery

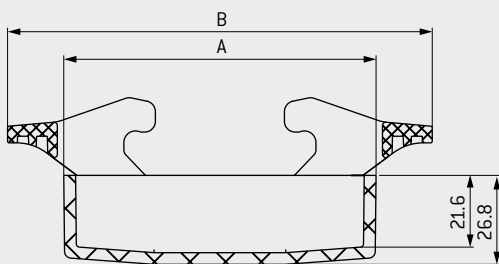

Size	Part number Protective cover for spindle locking	Part number Protective cover for transverse locking	Dim. A	Dim. B
			mm	mm
1	–	490.097.613.908.001	61	95
2	491.097.613.908.001	491.097.613.908.001	74	108
3	492.097.613.908.001	492.097.613.908.001	94	128
4	493.097.613.908.001	493.097.613.908.001	121	155

¹ IEC 60529:2013 (VDE 0470-1:2014)

METAL CABLE HOOD



Connector housing for assembly on the cable with top and side cable outlet

LEVER LOCKING

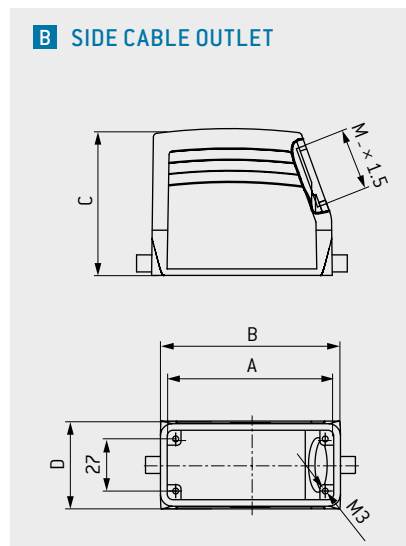
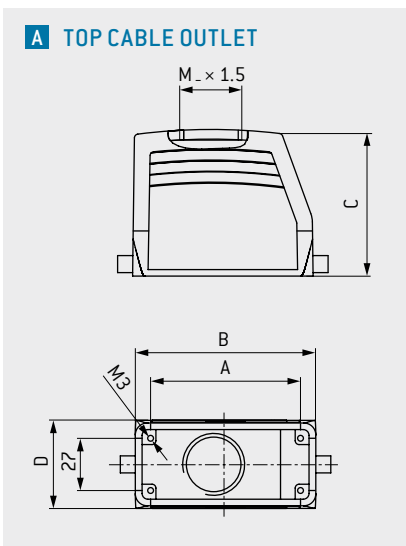

TECHNICAL DATA

Color of housing	Gray (standard similar to RAL 7001)
Material	aluminum die casting
International	
Protection class ¹	IP65
Operating temperature	in mated condition -40 °C to +125 °C
Cable clamp	see page 73
Adapter	for PG clamp see page 74

With lever locking, a minimum of 5,000 locking cycles are possible with lubrication. Up to 500 mating cycles, no lubrication is required.

Size	Part number A Top cable outlet	Part number B Side cable outlet	Dim. A mm	Dim. B mm	Dim. C mm	Dim. D mm	Dim. M Cable outlet	Part number protective cover (see page 71)
1	490.214.450.644.102	490.414.450.644.102	44	60	52	43	M25	490.097.500.644.000
	490.215.450.644.102	490.415.450.644.102			72		M32	
2	491.214.450.644.102	491.414.450.644.102	57	73	52	43	M25	491.097.212.644.000
	491.215.450.644.102	491.415.450.644.102			72		M32	
3	492.215.450.644.102	492.415.450.644.102	77.5	93.5	76	45.5	M32	492.097.214.644.000
4	493.215.450.644.102	493.415.450.644.102	104	120	76	45.5	M32	493.097.214.644.000
	493.217.550.644.000	493.417.550.644.000					M40	

¹ IEC 60529:2013 (VDE 0470-1:2014) (depends on the cable clamp(s) used)

METAL CABLE HOOD XXL

Connector housing for assembly on the cable with expanded assembly space and side and top M50 cable outlet



LEVER LOCKING



A TOP CABLE OUTLET



B SIDE CABLE OUTLET

A TOP CABLE OUTLET

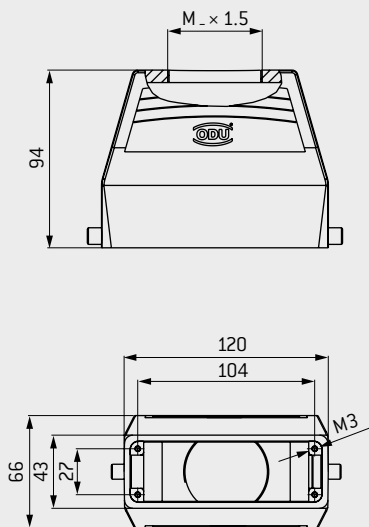

B SIDE CABLE OUTLET

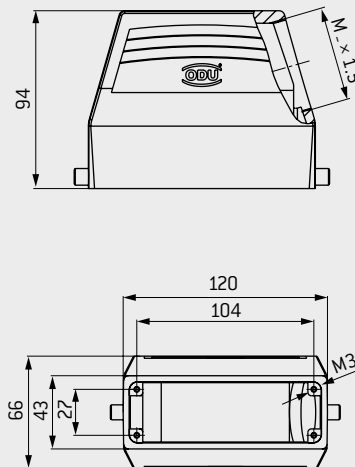

TECHNICAL DATA

Color of housing	Gray (standard similar to RAL 7001)
Material	Aluminum die casting
International	
Protection class ¹	IP65
Operating temperature	-40 °C to +125 °C
Cable clamp	in mated condition see page 73

With lever locking, a minimum of 5,000 locking cycles are possible with lubrication. Up to 500 mating cycles, no lubrication is required.

Size	Part number A Top cable outlet	Part number B Side cable outlet	Dim. M Cable outlet	Part number protective cover (see page 71)
4	493.218.550.644.000	493.419.550.644.000	M50	493.097.214.644.000

¹ IEC 60529:2013 (VDE 0470-1:2014) (depends on the cable clamp(s) used)

METAL BULKHEAD HOUSING



For mounting on your device

LEVER LOCKING

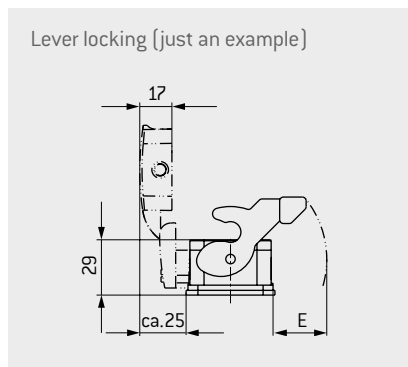
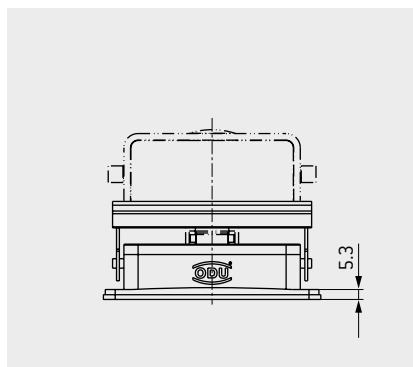

TECHNICAL DATA

Color of housing	Gray (standard similar to RAL 7001)
Material	Aluminum die casting
International Protection class ¹	IP65
Operating temperature	in mated condition -40 °C to +125 °C (short duration) -40 °C to +85 °C (continuous)
Sealing	NBR; sealing material FKM on request (to extend the temperature range)

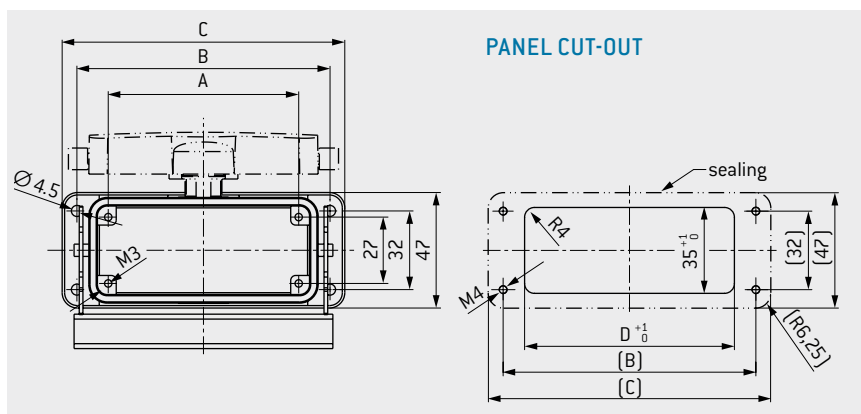

With lever locking, a minimum of 5,000 locking cycles are possible with lubrication. Up to 500 mating cycles, no lubrication is required.

Size	Part number A Without protective cover	Part number B With protective cover	Dim. A mm	Dim. B mm	Dim. C mm	Dim. D Panel cut-out mm	Dim. E mm
1	490.130.400.644.000	490.131.400.644.000	44	70	82	52.2	≈ 22
2	491.130.400.644.000	491.131.400.644.000	57	83	95	65.2	≈ 27
3	492.130.400.644.000	492.131.400.644.000	77.5	103	115	85.5	≈ 28
4	493.130.400.644.000	493.131.400.644.000	104	130	143	112.2	≈ 28

¹ IEC 60529:2013 (VDE 0470-1:2014) (depends on the cable hood used)

METAL SURFACE-MOUNTED HOUSING



For surface mounting on your device/wall with two side cable outlets

LEVER LOCKING

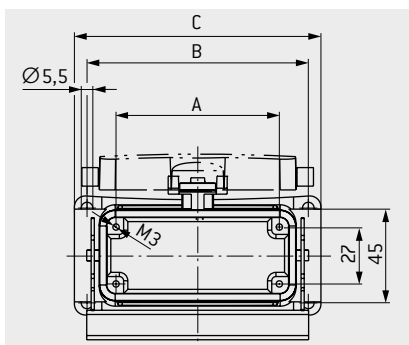
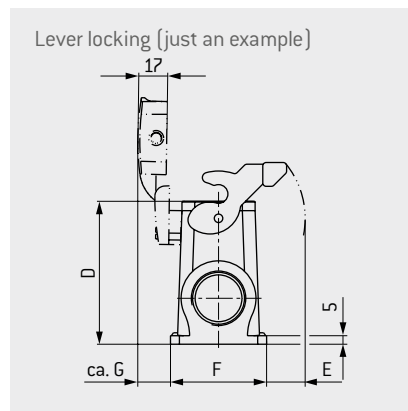
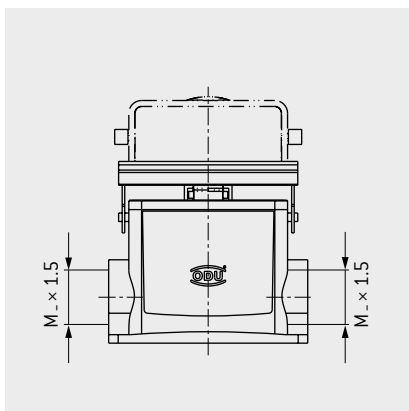

TECHNICAL DATA

Color of housing	Gray (standard similar to RAL 7001)
Material	aluminum die casting
International Protection class ¹	IP65
Operating temperature	in mated condition -40 °C to +125 °C (short duration) -40 °C to +85 °C (continuous)
Sealing	NBR; sealing material FKM on request (to extend the temperature range)
Adapter	for PG clamp see page 74

With lever locking, a minimum of 5,000 locking cycles are possible with lubrication. Up to 500 mating cycles, no lubrication is required.

Size	Part number A Without protective cover	Part number B With protective cover	Dim. A mm	Dim. B mm	Dim. C mm	Dim. D mm	Dim. E mm	Dim. F mm	Dim. G mm	Dim. M Cable outlet
1	490.133.450.644.102	490.135.450.644.102	44	70	82	74	≈ 17	55.5	20	M32
2	491.133.450.644.102	491.135.450.644.102	57	82	92.5	74	≈ 23	55.5	20	
3	492.133.450.644.102	492.135.450.644.102	77.5	105	117	84	≈ 23	56.5	20	
4	493.133.450.644.102	493.135.450.644.102	104	132	144	84	≈ 22	58	19	

M40 CABLE OUTLET AVAILABLE ON REQUEST

¹ IEC 60529:2013 (VDE 0470-1:2014) [depends on the cable clamp(s) and cable hood used]

METAL CABLE HOOD WIDE



With top and side cable outlet for double frame assembly

LEVER LOCKING

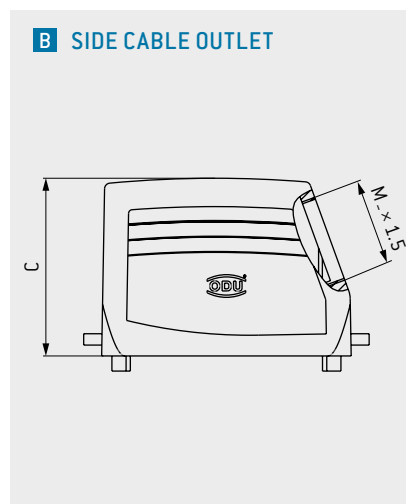
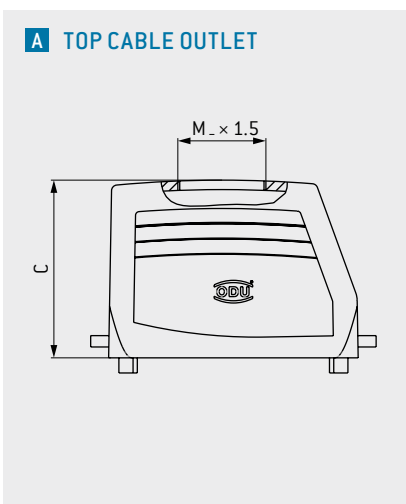

TECHNICAL DATA

Color of housing	Gray (standard similar to RAL 7001)
Material	aluminum die casting
International	
Protection class ¹	IP65
Operating temperature	in mated condition without housing sealing: -40 °C to +125 °C
Cable clamp	see page 73
Housing suitable for two standard frames size 3 or 4.	
2 × size 3 = size 5	
2 × size 4 = size 6	
With lever locking, a minimum of 5,000 locking cycles are possible with lubrication. Up to 500 mating cycles, no lubrication is required.	

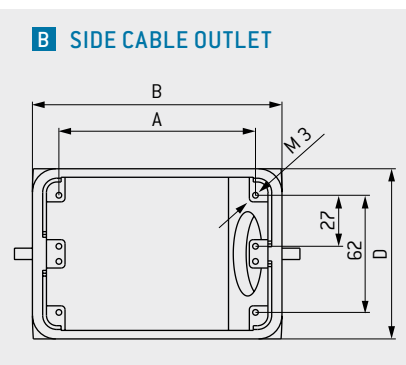
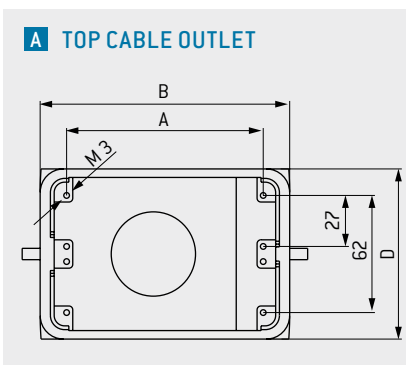

Size	Part number A Top cable outlet	Part number B Side cable outlet	Dim. A mm	Dim. B mm	Dim. C mm	Dim. D mm	Dim. M Cable outlet
5	494.215.550.644.000	494.415.550.644.000	77.5	94	79	82.5	M40
6	495.215.550.644.000	495.415.550.644.000	104	132	94	90	M50

¹ IEC 60529:2013 (VDE 0470-1:2014) [depends on the cable clamp(s) used]

METAL BULKHEAD HOUSING FOR CABLE HOOD WIDE

For mounting on your device



LEVER LOCKING

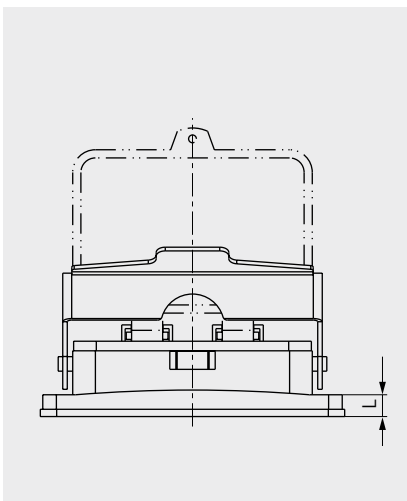

Lever locking (just an example)

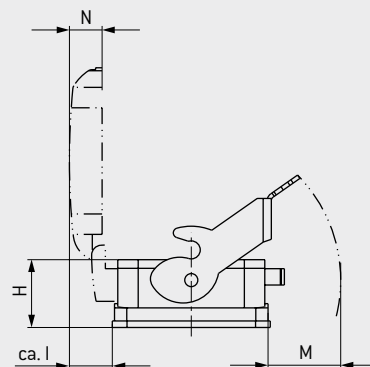

TECHNICAL DATA

Color of housing	Gray (standard similar to RAL 7001)
Material	aluminum die casting
International Protection class ¹	IP65
Operating temperature	in mated condition -40 °C to +125 °C (short duration) -40 °C to +85 °C (continuous)
Sealing	NBR; sealing material FKM on request (to extend the temperature range)

With lever locking, a minimum of 5,000 locking cycles are possible with lubrication. Up to 500 mating cycles, no lubrication is required.

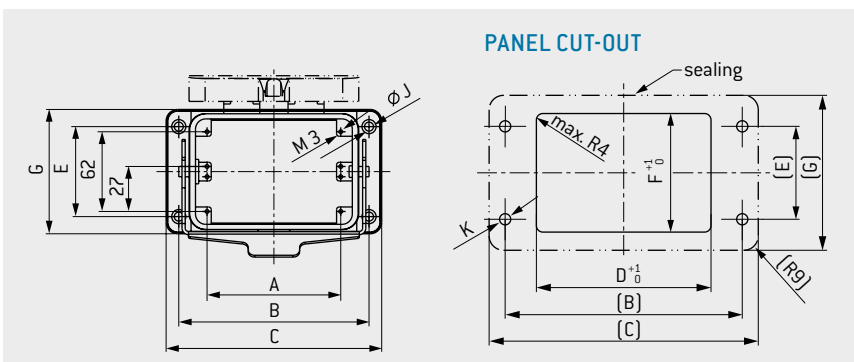

Size	Part number A Without protective cover	Part number B With protective cover	Dim. A mm	Dim. B mm	Dim. C mm	Dim. D mm	Dim. E mm	Dim. F mm	Dim. G mm	Dim. H mm	Dim. I mm	Dim. J mm	Dim. K mm	Dim. L mm	Dim. M mm	Dim. N mm
5	494.130.500.644.000	494.131.500.644.000	77.5	110	127	79	65	74	89	38	≈ 23	5.5	M5	7	31	17
6	495.130.500.644.000	495.131.500.644.000	104	148	168	117	70	80	96.7	41.5	≈ 26	7	M6	12	43	20

¹ IEC 60529:2013 (VDE 0470-1:2014) (depends on the cable hood wide used)

METAL CABLE-TO-CABLE HOOD



With top cable outlet for a flying cable-to-cable connection

LEVER LOCKING



Lever locking (just an example)

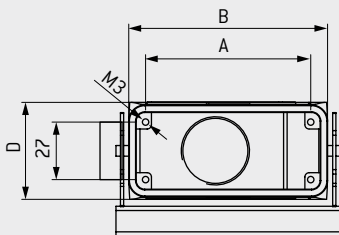
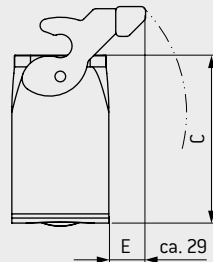
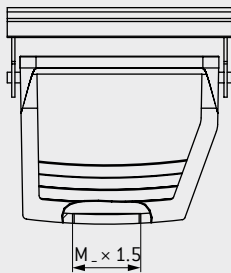

TECHNICAL DATA

To build a cable-to-cable connection.

Suitable for use with cable hoods (page 64).

Color of housing Gray (standard similar to RAL 7001)

Material aluminum die casting

International

Protection class¹ IP65

in mated condition

Operating temperature –40 °C to +125 °C

(short duration)

–40 °C to +85 °C

(continuous)

Sealing NBR; sealing material

FKM on request (to

extend the temperature

range)

Cable clamp see page 73

Adapter for PG clamp

see page 74

With lever locking, a minimum of 5,000 locking cycles are possible with lubrication. Up to 500 mating cycles, no lubrication is required.

Size	Part number	Dim. A	Dim. B	Dim. C	Dim. D	Dim. M	Part number
		mm	mm	mm	mm	Cable outlet	Protective cover (see page 71)
1	490.331.450.644.102	44	60	75	43	M32	490.097.500.644.001
2	491.331.450.644.102	57	73	75	43		491.097.133.644.000
3	492.331.450.644.102	77.5	93.3	79	45.5		492.097.133.644.000
4	493.331.450.644.102	104	120	79	45.5		493.097.133.644.000

M40 CABLE OUTLET AVAILABLE ON REQUEST

¹ IEC 60529:2013 (VDE 0470-1:2014) [depends on the cable clamp(s) used]

METAL PROTECTIVE COVER



For metal housing

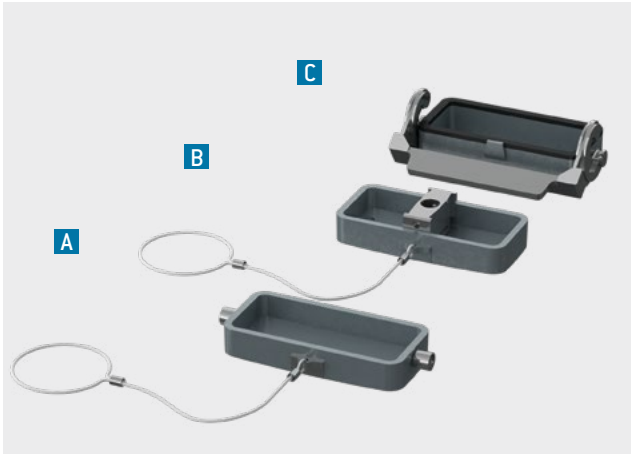

TECHNICAL DATA

Color Gray (standard, similar to RAL 7001)

International Protection class IP65 in locked condition

Metal protective cover with locking latch [C]
Metal protective cover with bolt and lanyard [A]

International Protection class IP54 in locked condition

Metal protective cover with center module for spindle locking and lanyard [B]

Material aluminum die casting (body)
Temperature range $-40\text{ }^{\circ}\text{C}$ to $+125\text{ }^{\circ}\text{C}$
Sealing NBR; sealing material

A METAL PROTECTIVE COVER
for bulkhead or surface-mounted housing and cable-to-cable hood

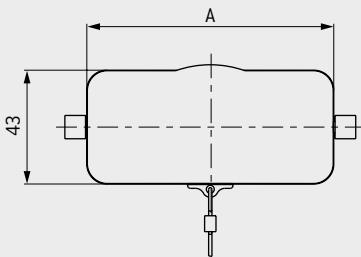

A VIEW WITHOUT LANYARD

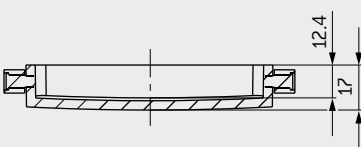

B METAL PROTECTIVE COVER
for cable hood and cable hood XXL for spindle locking

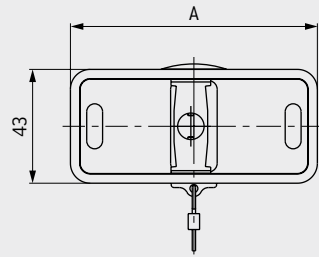

B VIEW WITHOUT LANYARD

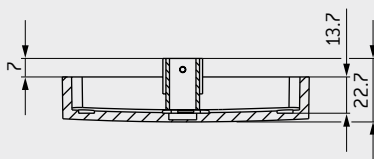

C METAL PROTECTIVE COVER
for cable hood and cable hood XXL with lever locking

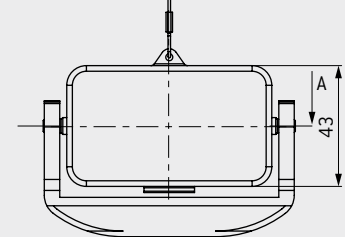

Lever locking, just an example

C VIEW WITHOUT LOCKING LATCH

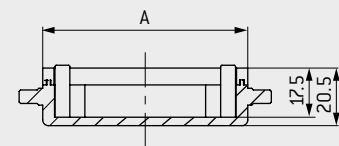

Size	IP65 Part number A Metal protective cover with bolt and lanyard	IP50 Part number B ¹ Metal protective cover for spindle locking with lanyard and center module	IP65 Part number C Metal protective cover with locking latch	Dim. A mm
1	490.097.500.644.001	—	490.097.500.644.000	60
2	491.097.133.644.000	491.097.613.644.001	491.097.212.644.000	73
3	492.097.133.644.000	492.097.613.644.001	492.097.214.644.000	93.5
4/XXL	493.097.133.644.000	493.097.613.644.001	493.097.214.644.000	120

¹ This cover cannot be used in conjunction with a coded spindle.

ODU-MAC® BLUE-LINE FRAME FOR HOUSING



With grounding for housing



TECHNICAL DATA

- Material: nickel-plated zinc die casting
- 1 unit = 2.4 mm

Included in the scope of delivery: secondary locking part

For use and assembly, see page [37](#)



SOCKET FRAME WITH GUIDE BUSHING

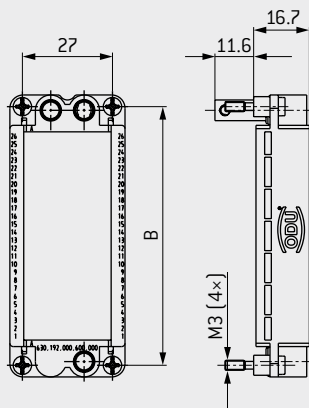

Sockets in bulkhead and surface-mounted housing or cable-to-cable hood. Pins in the cable hood. Modules are not mounted, contacts are supplied loose. See the options for coding from page [76](#).

PIN FRAME WITH GUIDING PIN

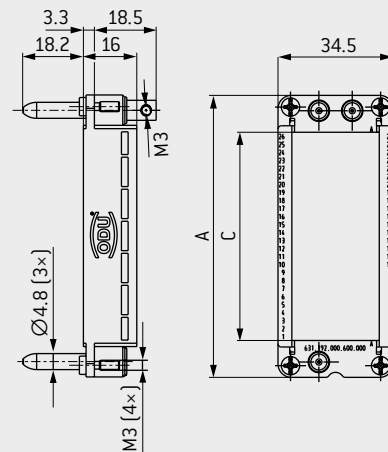

For the height of the contact pins, the same dimensions as described for the respective modules apply.

Size	Part number Socket frame	Part number Pin frame	Max. units × 2.4 mm ¹	Dim. A mm	Dim. B mm	Dim. C mm
1	630.190.000.600.000	631.190.000.600.000	12	51	44	12 × 2.4 = 28.8
2	630.191.000.600.000	631.191.000.600.000	18	64	57	18 × 2.4 = 43.2
3	630.192.000.600.000	631.192.000.600.000	26	84.5	77.5	26 × 2.4 = 62.4
4	630.193.000.600.000	631.193.000.600.000	37	111	104	37 × 2.4 = 88.8
RAPID	630.193.000.600.000	630.193.000.600.001	37	111	104	37 × 2.4 = 88.8

Please note that when equipping a cable hood wide, the frames must be ordered in duplicate.

¹ If the configuration doesn't fill the frame completely, please use blank modules (see page [150](#))

CABLE CLAMP AND REDUCING RING



CABLE CLAMP¹ FOR HOUSINGS ACCORDING TO IEC 62444:2010 (VDE 0619:2014)



TECHNICAL DATA

Material for body	PA
Sealing	NBR; sealing material
International	
Protection class	IP68 to 5 bar
Temperature range	-40 °C to +100 °C

EMC and metal clamps available on request

Part number	Thread	Color	Width across flats	Tightening torque Nm	Cable-Ø mm		
					Min.	Max.	
027.825.060.130.007	M25 × 1.5	Gray	30	8	6	13	
027.825.090.170.007					9	17	
027.832.070.150.007	M32 × 1.5		36	10	7	15	
027.832.110.210.007					11	21	
027.840.190.280.007	M40 × 1.5		46	13	19	28	
027.850.270.350.007	M50 × 1.5		55	15	27	35	
027.825.060.130.003	M25 × 1.5		White (RAL 7035)	30	8	6	13
027.825.090.170.003						9	17
027.832.070.150.003	M32 × 1.5			36	10	7	15
027.832.110.210.003						11	21
027.840.190.280.003	M40 × 1.5	46		13	19	28	
027.832.070.150.008	M32 × 1.5	Black		36	10	7	15
027.832.110.210.008	M32 × 1.5					11	21
027.840.190.280.008	M40 × 1.5					19	28

REDUCING RING FOR PLASTIC HOUSING



TECHNICAL DATA

Color	Black (RAL 9005)
Material	plastic PA6 GF20, UL 94-V0
International	
Protection class	IP65
Temperature range	-40 °C to 125 °C
Sealing	NBR; sealing material
Tightening torque	4 ± 0.5 Nm

Part number	Outside thread	Inside thread
921.000.006.000.360	M32 × 1.5	M25 × 1.5
921.000.006.000.356	M40 × 1.5	M32 × 1.5

¹ Cable clamp not included in the scope of delivery, but O-ring is supplied with the housing.

ADAPTER RING, BLIND PLUG, AND LOCKNUT



ADAPTER RING FOR CABLE CLAMP WITH PG THREAD

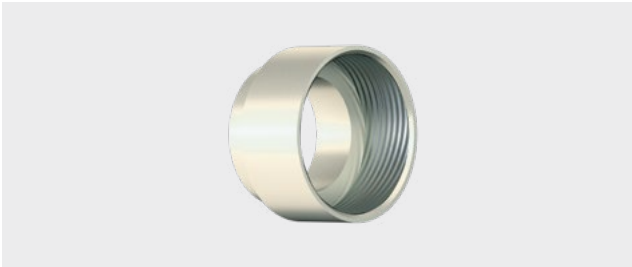

TECHNICAL DATA

Material nickel-plated brass

Part number	Outside thread	Inside thread
921.000.006.000.254	M25 × 1.5	PG 21
921.000.006.000.255	M32 × 1.5	PG 29
921.000.006.000.267	M32 × 1.5	M40 × 1.5

BLIND PLUG FOR SURFACE-MOUNTED HOUSING



TECHNICAL DATA

Color Gray
 Material PA glass-fiber reinforced
 International Protection class IP68
 Temperature range -40 °C to +125 °C
 Sealing NBR; sealing material

Part number	Thread
921.000.006.000.279	M25 × 1.5
921.000.006.000.268	M32 × 1.5
On request	M40 × 1.5
On request	M50 × 1.5

LOCKNUT FOR CABLE CLAMP



TECHNICAL DATA

Material nickel-plated brass

Part number	Thread
931.000.003.000.112	M32 × 1.5
931.000.003.000.113	M40 × 1.5

For fixing the cable clamp in the ODU-MAC® strain-relief housing

PROTECTIVE TRANSPORT COVER AND SECONDARY LOCKING PART



PROTECTIVE TRANSPORT COVER FOR METAL HOUSING – for protecting the assembled cable hood during transport



TECHNICAL DATA

Material plastic PP
Color Black (similar to RAL 9002)

Size	Dim. B mm	Part number	
		With holding rope	Without holding rope
1	63	490.097.900.924.000	490.097.900.924.101
2	76	491.097.900.924.000	491.097.900.924.101
3	96.5	492.097.900.924.000	492.097.900.924.101
4/XXL	123	493.097.900.924.000	493.097.900.924.101

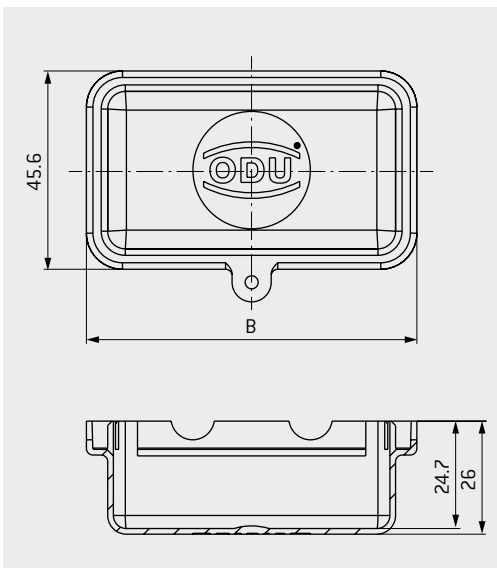

SECONDARY LOCKING FOR MODULES

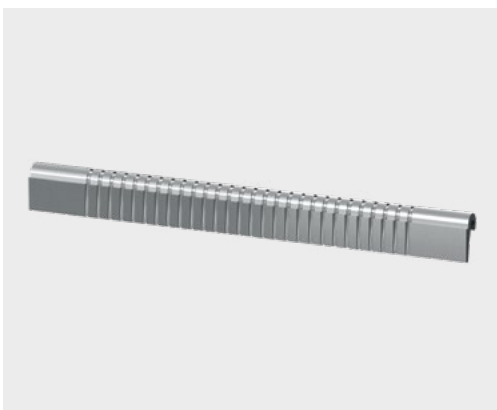

TECHNICAL DATA

Material thermoplastic, glass-fiber reinforced

Part number – only if a replacement is required¹

631.000.001.923.000

¹ The secondary locking part is included in the standard scope of delivery.

CODING OPTIONS FOR HOUSINGS WITH LEVER LOCKING



To prevent mismatching

In order to prevent mismatching, it is in some cases useful to provide the connection systems with a coding system.

Instead of cylinder screws, coding pins and coding sockets can be used in the housing of the ODU-MAC® Blue-Line. ODU offers 16 different coding options. Standard frames do not include additional coding upon delivery. If several adjacent connectors are used, this can prevent mismatching.



CODING OPTIONS

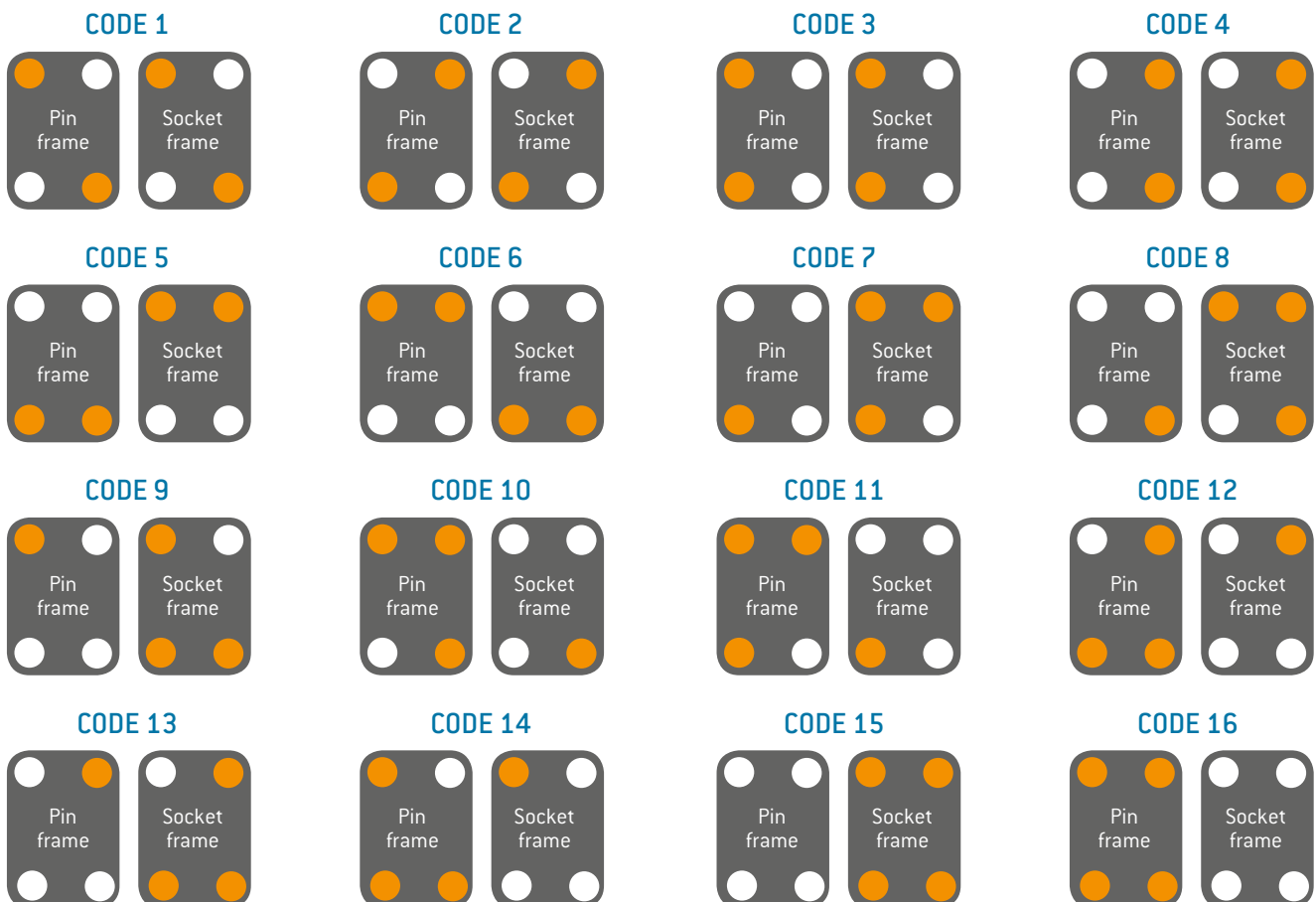

- = Coding pin
- = Coding socket



CODING EXAMPLE

CODE 1

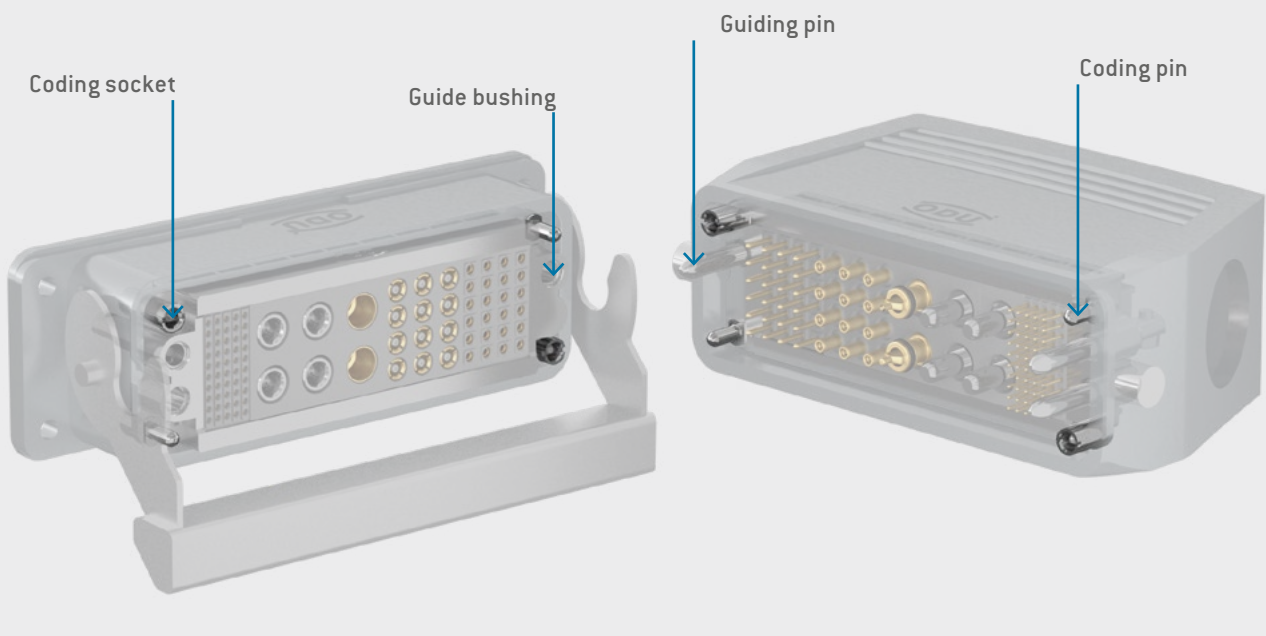
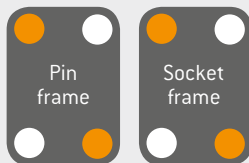

Frame	Part number matching the frame no.	Coding	
		● Part number pin	● Part number socket
Pin	631.19X.000.600.000	631.090.301.700.000 	630.090.302.700.000
Socket	630.19X.000.600.000	631.090.302.700.000 	630.090.301.700.000

PART NUMBER BASIC TOOL, TORQUE WRENCH/1.2 Nm: 598.054.002.000.000

PART NUMBER TOOL INSERT FOR ASSEMBLY OF CODING PIN: 598.054.203.000.000

PART NUMBER TOOL INSERT FOR ASSEMBLY OF CODING SOCKET: 598.054.110.000.000

An overview of all tools, see from page [153](#).

CODING OPTIONS FOR HOUSINGS WITH SPINDLE LOCKING



To prevent mismatching

In order to prevent mismatching, it is in some cases useful to provide the connection systems with a coding system.

Instead of cylinder screws, coding pins and coding sockets can be used in the housing of the ODU-MAC® Blue-Line. ODU offers 4 coding variations with these coding options in combination with spindle locking. Standard frames do not include additional coding upon delivery. If several adjacent connectors are used, this can prevent mismatching.

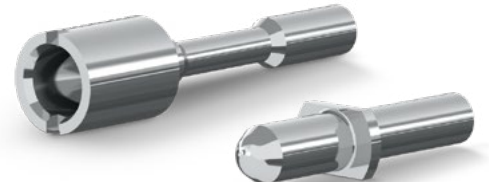

Alternatively, or if additional coding options are required, ODU offers an innovative option with the coded spindle on pages [80](#) and [81](#).

CODING OPTIONS

CODE 1

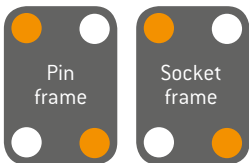

CODE 2

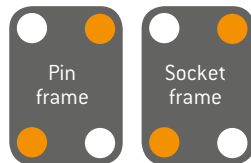

CODE 5

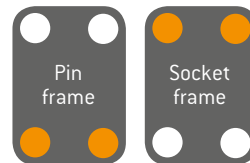

CODE 6

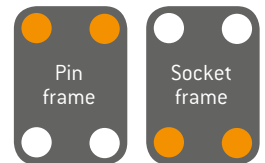

● = Coding pin

○ = Coding socket



CODING EXAMPLE

CODE 2

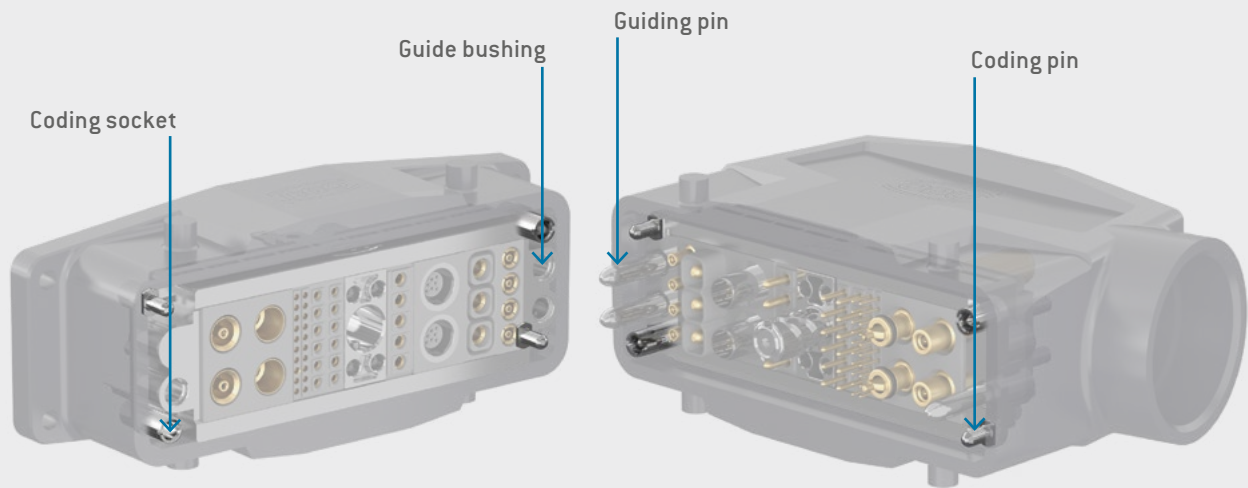
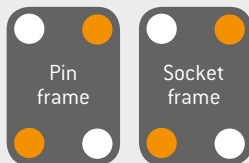

Frame	Part number matching the frame no.	Coding	
		● Part number pin	● Part number socket
Pin	631.19X.000.600.000	631.090.301.700.000 	630.090.302.700.000
Socket	630.19X.000.600.000	631.090.302.700.000 	630.090.301.700.000

PART NUMBER BASIC TOOL, TORQUE WRENCH/1.2 Nm: 598.054.002.000.000

PART NUMBER TOOL INSERT FOR ASSEMBLY OF CODING PIN: 598.054.203.000.000

PART NUMBER TOOL INSERT FOR ASSEMBLY OF CODING SOCKET: 598.054.110.000.000

An overview of all tools, see from page 153.

CODING OPTIONS FOR CODED SPINDLES



To prevent mismatching

In order to prevent mismatching, it is in some cases useful to provide the connection systems with a coding system.

For this purpose, ODU has developed innovative coding that is directly integrated into the spindle for the ODU-MAC® Blue-Line housing versions. ODU provides up to 6 different coding options by installing 2 coding pins in the spindle locking and 2 closure plugs in the center module. If several adjacent connectors are used, this can prevent mismatching.



CODING OPTIONS

CODE A

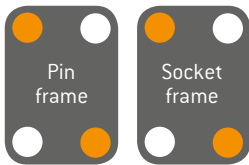

CODE B

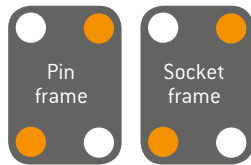

CODE C

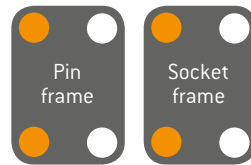

CODE D

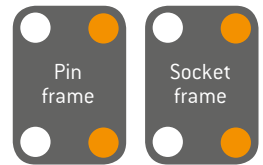

CODE E

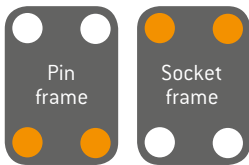

CODE F

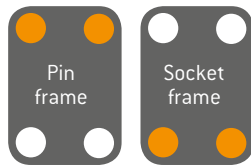

- = Coding pin
- = Closure plug



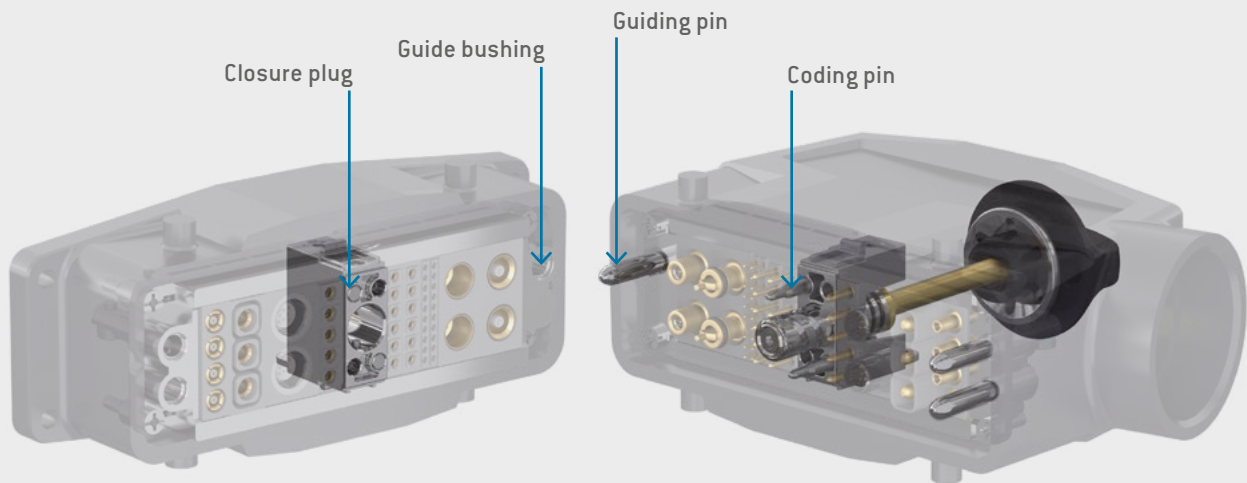
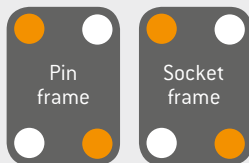

CODING EXAMPLE

CODE B



Size	WITH CODING ¹		Angle of rotation
	Part number Center module for spindle for bulkhead and surface-mounted housing and cable-to-cable hood	Part number Spindle locking for cable hood	
2 (52 mm high)	634.090.001.304.010	635.091.003.200.010	180°
2 (72 mm high)	634.090.001.304.010	635.091.001.200.010	180°
3/4	634.090.001.304.010	635.092.011.200.010	270°
3/4	634.090.001.304.010	635.092.011.200.013	360°
XXL/RAPID	634.090.001.304.010	635.093.011.200.010	270°
XXL/RAPID	634.090.001.304.010	635.093.011.200.013	360°

¹ Coding pins and closure plugs are included as loose parts.

ONLY IF A REPLACEMENT IS REQUIRED ²	
Part number Coding pin	Part number Closure plug
	
635.090.105.902.000	634.090.106.902.000

² They are included in the standard scope of delivery.

TORQUE WRENCH/0.9 Nm FOR LEFT-HAND THREAD
PART NUMBER BIT SLOT FOR THE ASSEMBLY OF THE SPINDLE CODING: 598.054.109.000.000

An overview of all tools, see from page [153](#).

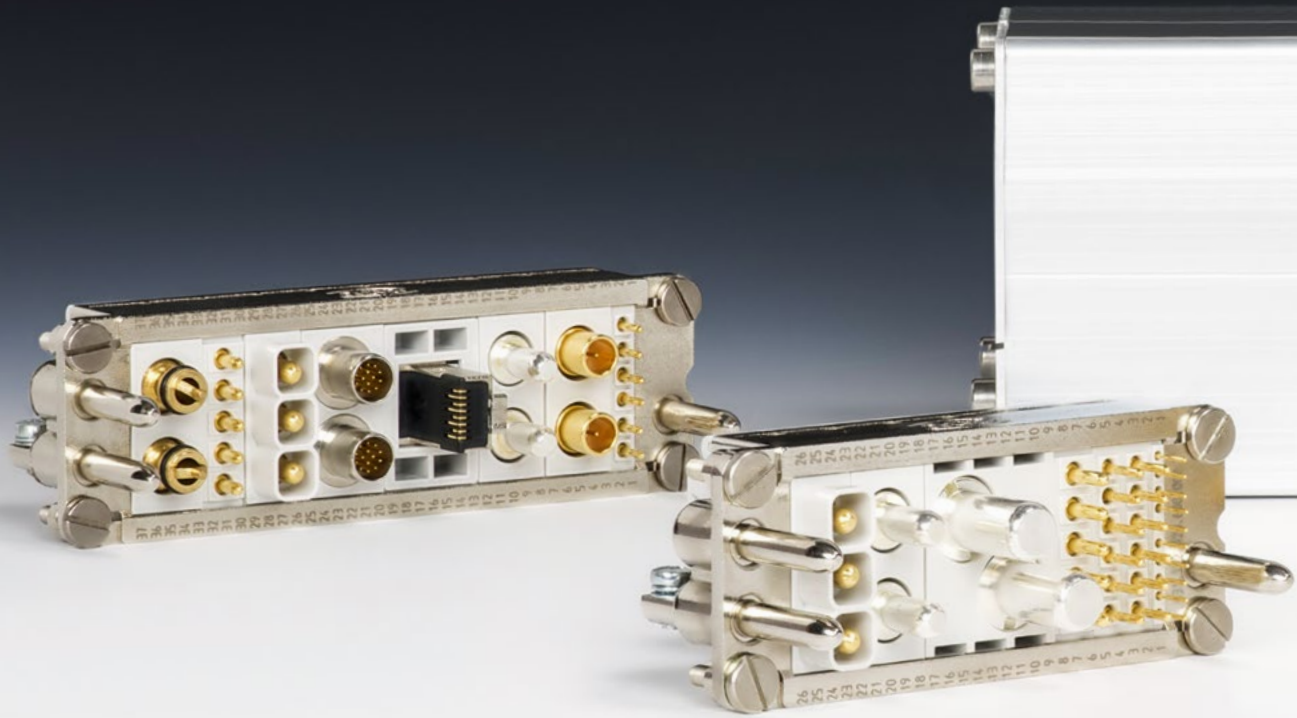

EASILY CONFIGURE THE ODU-MAC® BLUE-LINE
ONLINE AT: WWW.ODU-MAC.COM/EN/

ODU-MAC®

[Table of contents](#)

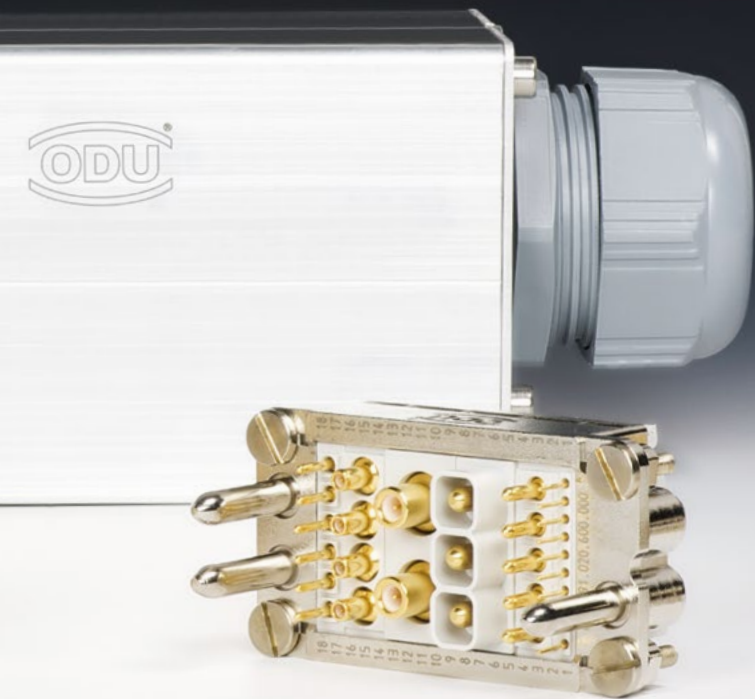

AUTOMATIC DOCKING

Requirements of the complete system	84
ODU-MAC® Blue-Line docking frame	86
ODU-MAC® Blue-Line strain-relief housing	87

REQUIREMENTS OF THE COMPLETE SYSTEM

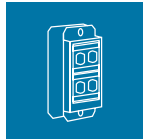

High mating cycles and perfect transfer rates – in order to ensure these for automatic docking over the long term, the docking system must be a design consideration (e.g., centering systems).

Clean and smooth docking is secured by special guiding pins that are designed for the forces which guide the connector. Please note the mechanical requirements behind the design.

MAXIMUM PERMISSIBLE OFFSET + STANDARD GAP MEASURE IN MATED CONDITION (RADIAL PLAY)

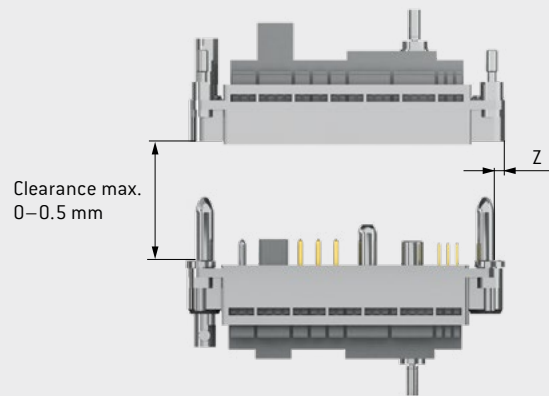
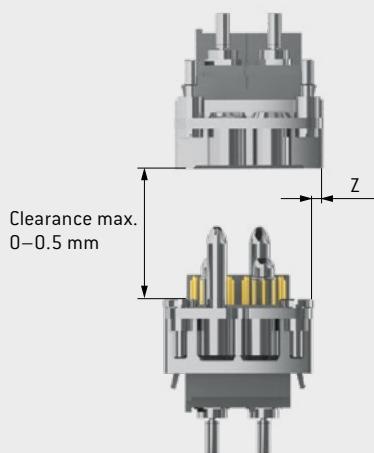

Frame	Tolerance
Docking frame	$\pm 0.6 \text{ mm}$

The maximum permissible gap between socket and pin pieces is 0.5 mm as standard. Extension with long contact pins is possible.

MAXIMUM PERMISSIBLE ANGLE DEVIATION WHEN MATING

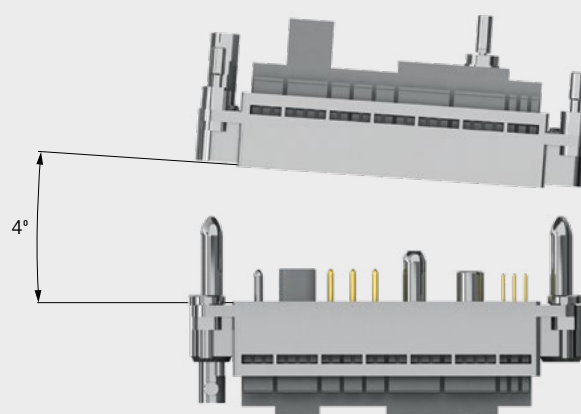
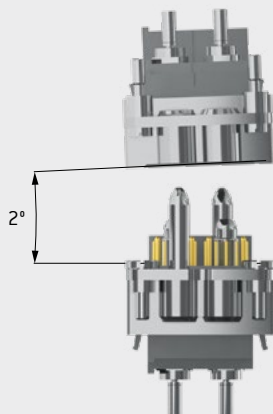

OUR TEAM IS HAPPY TO ANSWER ANY QUERIES YOU MAY HAVE.

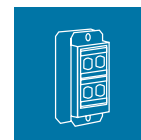

YOU REQUIRE GREATER VARIETY? A MORE COMPREHENSIVE OFFER IS PROVIDED BY OUR ODU-MAC® SILVER-LINE – THE SPECIALIST FOR AUTOMATIC DOCKING SOLUTIONS.

ALIGNMENT SYSTEM (MECHANICAL NECESSITY)

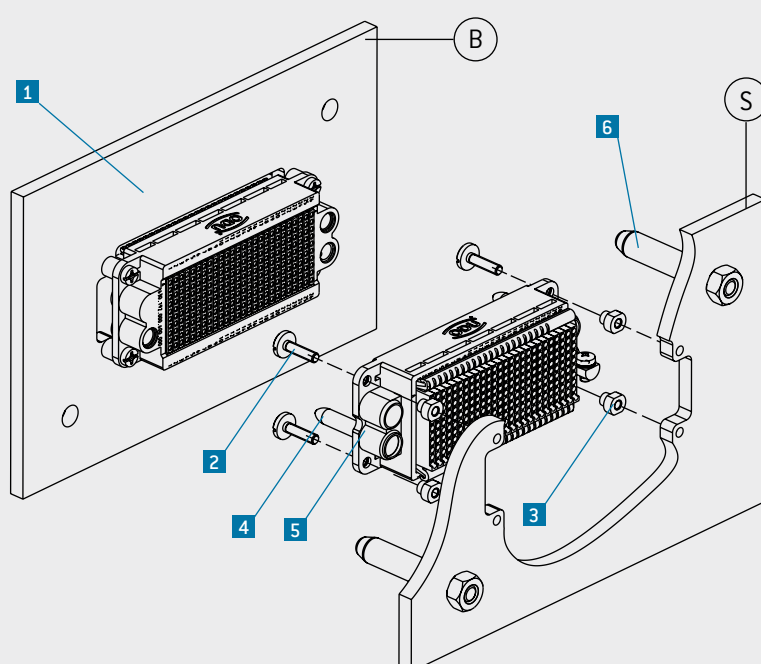

Strain relief for the cables/strands must be provided by the customer. Please see our strain-relief housing page [87](#).

- 1** ODU-MAC® Blue-Line socket piece (fixed) (screwed tight without play to wall B)
- 2** Fastening screw
- 3** Tolerance compensation:
Axial play: 0.1 mm
- 4** Radial play: +/- 0.6 mm
- 5** Pins for self-centering of ODU-MAC® Blue-Line ODU-MAC® Blue-Line pin piece (floating)
- 6** (with play via centering bushing; screwed tight to wall S)
Pin for guiding from wall B to S (to be done by customer)

The values for the mated condition (pin S in B) result from the axial play of the centering bushings.

NOTE: AUTOMATIC DOCKING SYSTEMS

- The pin piece of the ODU-MAC® Blue-Line is to be fixed with the centering bushings supplied and so that the frame can float.
- The guiding system of the ODU-MAC® Blue-Line provides no guiding hardware for the overall plug-in.
- The maximum permissible gap between socket and pin pieces is 0.5 mm as standard. Extension with long contact pins is possible.
- An alignment system (e.g., guide rails) must be provided through the plug-in unit. The maximum permissible alignment error is, for example, less than +/- 0.6 mm radial for the ODU-MAC® Blue-Line docking frame.
- Strain relief for the cables/strands must be provided by the customer, or use our strain-relief housing, see page [87](#).

FAILURE TO OBSERVE THESE SPECIFICATIONS MAY RESULT IN DAMAGE.

ODU-MAC® BLUE-LINE DOCKING FRAME

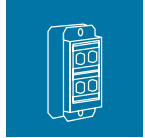

Standard solution for docking applications (such as rack & panel)

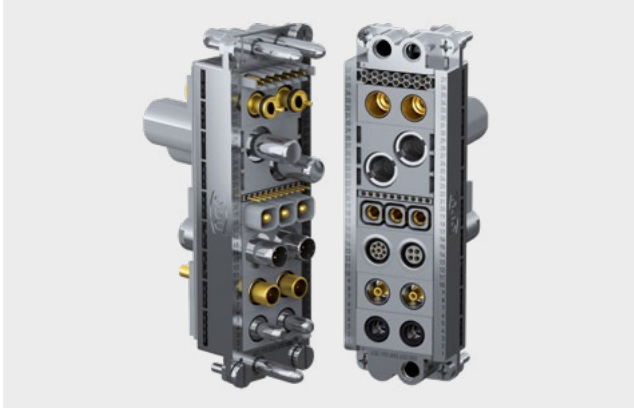

TECHNICAL DATA

- Tolerance compensation:
Axial play: min. 0.1 mm
Radial play: +/- 0.6 mm
- Pin piece (floating)

Included in the scope of delivery: secondary locking part

For use and assembly, see page [37](#)



SOCKET FRAME WITH GUIDE BUSHING

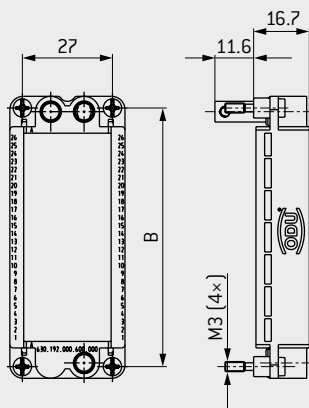

PIN FRAME WITH GUIDING PIN

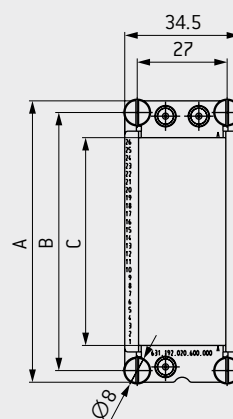
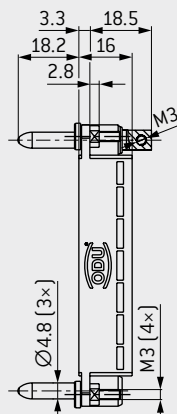

PANEL CUT-OUT

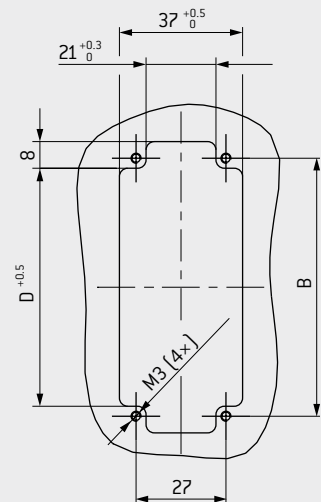

Modules are not mounted, contacts are supplied loose.

For the height of the contact pins, the same dimensions as described for the respective modules apply.

Size	Part number Socket frame	Part number Pin frame	Max. units × 2.4 mm ¹	Dim. A mm	Dim. B mm	Dim. C mm	Dim. D mm
1	630.190.000.600.000	631.190.020.600.000	12	51	44	12 × 2.4 = 28.8	38
2	630.191.000.600.000	631.191.020.600.000	18	64	57	18 × 2.4 = 43.2	51
3	630.192.000.600.000	631.192.020.600.000	26	84.5	77.5	26 × 2.4 = 62.4	71.5
4	630.193.000.600.000	631.193.020.600.000	37	111	104	37 × 2.4 = 88.8	98

¹ If the configuration doesn't fill the frame completely, please use blank modules (see page [150](#)).

ODU-MAC® BLUE-LINE STRAIN-RELIEF HOUSING

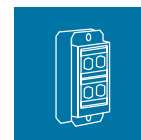

Accessories for docking solutions



Graphic shows optional cable clamp, it is not automatically included in the scope of delivery.

APPLICATION EXAMPLE

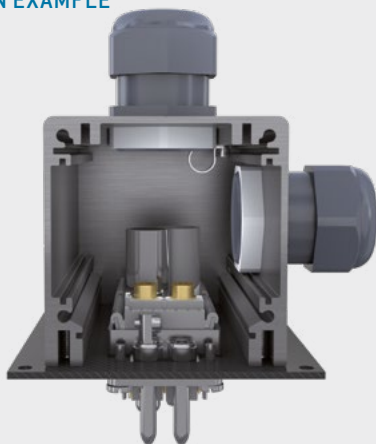

Graphic shows optional cable clamp, it is not automatically included in the scope of delivery. Additional M32 cable clamps can be attached by the customer.

TECHNICAL DATA

- Material: aluminum
- Operating temperature: $-40\text{ }^{\circ}\text{C}$ to $+125\text{ }^{\circ}\text{C}$
- International Protection class¹ can be adjusted individually
- Cable clamps, see page [73](#)
- Locknut for cable clamp, see page [74](#)

FEATURES

- Resistant and compact
- Protection of the termination area
- Individual strain-relief variations, cable outlets as well as grounding connections
- Suitable for all ODU-MAC® docking frames (additional lengths available on request)
- Optional fixing of the PCBs and components in the protected interior
- ODU logo included as standard; customer logo can also be delivered on request

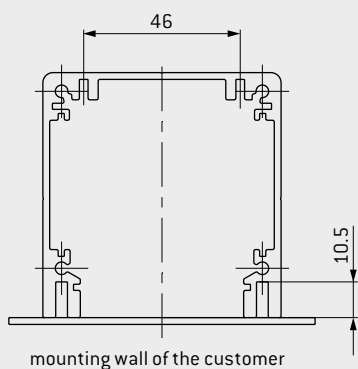

¹ A higher International Protection class is possible for additional sealing of the housing

ODU-MAC[®] BLUE-LINE STRAIN-RELIEF HOUSING

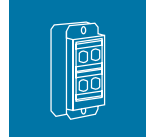

Accessories for docking solutions

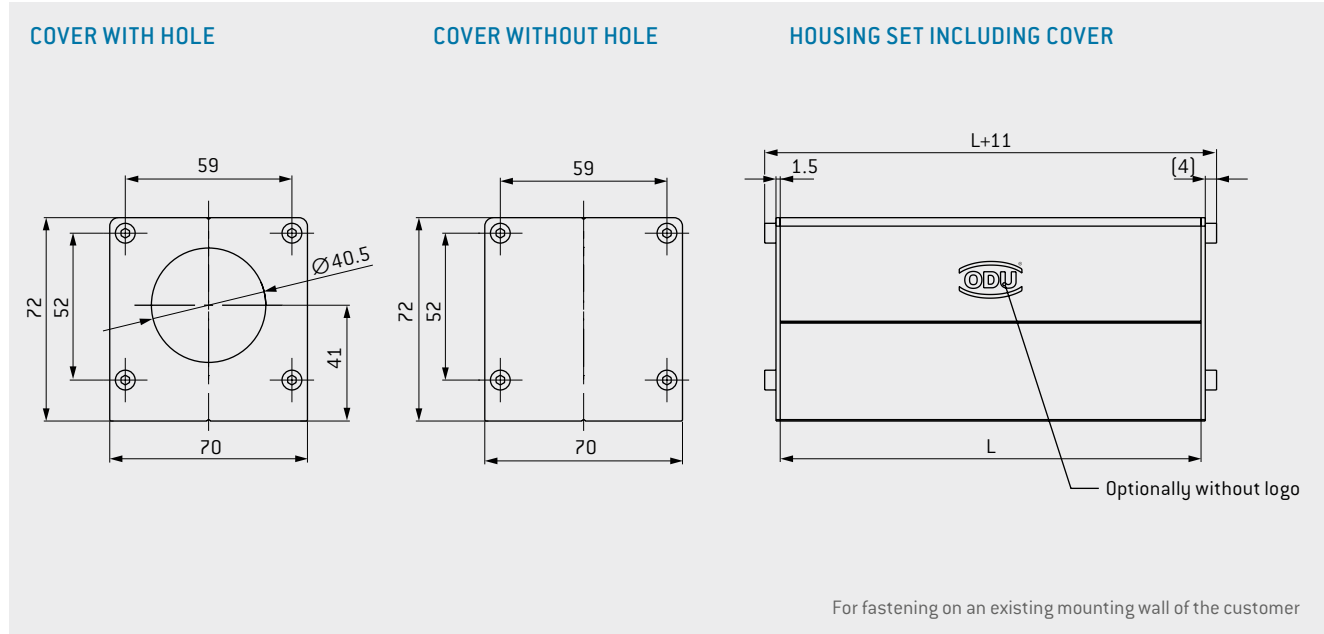

The set comprises a housing profile including 2 covers and corresponding fastening screws for assembly of the included cover. Fastening material for an existing mounting wall of the customer is not included in the scope of delivery.

Part number 2 × cover without hole	Part number 1 × cover with / 1 × cover without hole	Part number 2 × cover with hole	Frame size	Dim. L mm
616.010.100.600.000	616.010.114.600.000	616.010.144.600.000	1–3	97
616.020.100.600.000	616.020.114.600.000	616.020.144.600.000	4	123

FOR YOUR NOTES

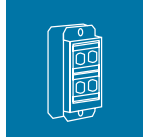

A large, empty light gray rectangular area intended for taking notes.



EASILY CONFIGURE THE ODU-MAC® BLUE-LINE
ONLINE AT: WWW.ODU-MAC.COM/EN/

ODU-MAC®

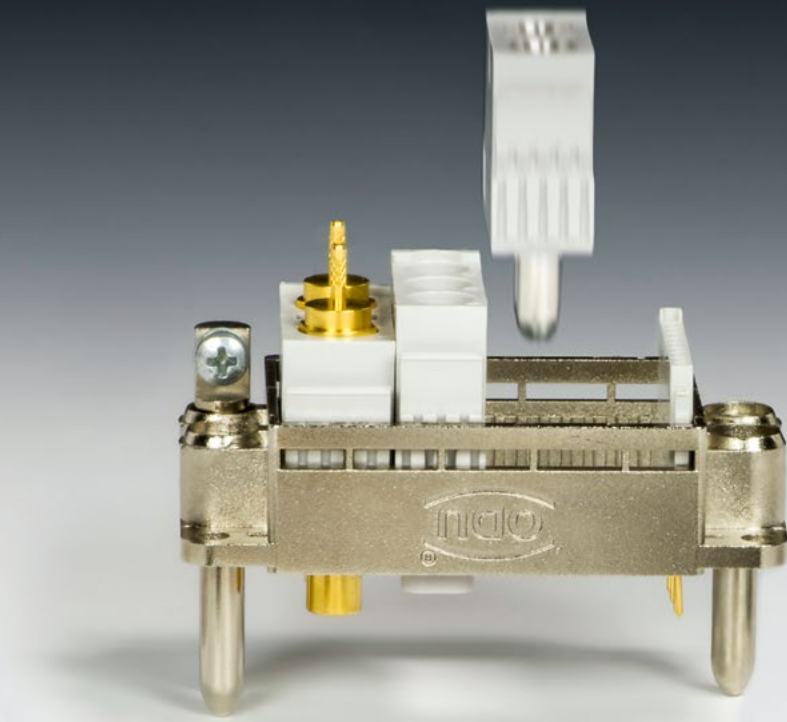

MODULES

Overview	92
Signal	98
PCB termination modules	106
Power	114
High current	116
Coax	122
Compressed air and fluid coupling with M5 termination accessories	130
Shielded feedthrough/high-speed connector	138
Combination module	144
Fiber optic	148
Blank modules	150

OVERVIEW OF ALL MODULES



Modules marked with this symbol can be used in the PUSH-LOCK; note the space requirements.

	Modules	Description	Units/width	Features	Page
Signal		20 contacts Contact-Ø: 0.7 mm	 4.8 mm	Maximum packing density and pin protection Operating voltage ¹ 250 V Rated surge voltage ¹ 2,000 V Max. continuous current ² 11 A for 0.38 mm ² Pollution degree ¹ 2 Mating cycles min. 10,000	98
		10 contacts Contact-Ø: 0.7 mm	 2.4 mm	Maximum packing density Operating voltage ¹ 320 V Rated surge voltage ¹ 2,500 V Max. continuous current ² 11 A for 0.38 mm ² Pollution degree ¹ 2 Mating cycles min. 10,000	100
		6 contacts Contact-Ø: 1.3 mm	 4.8 mm	Operating voltage ¹ 400 V Rated surge voltage ¹ 2,500 V Max. continuous current ² 19.5 A for 1 mm ² Pollution degree ¹ 2 Mating cycles min. 10,000	102
		5 contacts Contact-Ø: 2 mm	 7.2 mm	Operating voltage ¹ 630 V Rated surge voltage ¹ 3,000 V Max. continuous current ² 33 A for 2.5 mm ² Pollution degree ¹ 2 Mating cycles min. 10,000	104
PCB termination modules		20 contacts Contact-Ø: 0.7 mm	 4.8 mm	Operating voltage ¹ 250 V Rated surge voltage ¹ 2,500 V Max. continuous current ² 7 A Pollution degree ¹ 2 Mating cycles min. 10,000	106
		10 contacts Contact-Ø: 0.7 mm	 2.4 mm	Maximum packing density Operating voltage ¹ 320 V Rated surge voltage ¹ 2,500 V Max. continuous current ² 7 A Pollution degree ¹ 2 Mating cycles min. 10,000	108

¹According to IEC 60664-1:2007 (VDE 0110-1:2008) for pollution degree 2 ²For a definition of max. continuous current, see page [172](#)

OVERVIEW OF ALL MODULES



Modules marked with this symbol can be used in the PUSH-LOCK; note the space requirements.

	Modules	Description	Units/width	Features	Page
PCB termination modules		6 contacts Contact-Ø: 1.3 mm	 4.8 mm	Operating voltage ¹ 400 V Rated surge voltage ¹ 2,500 V Max. continuous current ² 13 A Pollution degree ¹ 2 Mating cycles min. 10,000	110
		5 contacts Contact-Ø: 2 mm	 7.2 mm	Operating voltage ¹ 630 V Rated surge voltage ¹ 2,500 V Max. continuous current ² 25 A Pollution degree ¹ 2 Mating cycles min. 10,000	112
Power		3 contacts Contact-Ø: 3.5 mm	 9.6 mm	High voltage Operating voltage ¹ 2,500 V Rated surge voltage ¹ 10,000 V Max. continuous current ² 58 A for 6 mm ² Pollution degree ¹ 2 Mating cycles min. 10,000	114
High current		2 contacts for turned contacts with ODU LAMTAC ^{®3} Contact-Ø: 5 mm	 12 mm	Operating voltage ¹ 400 V Rated surge voltage ¹ 4,000 V Max. continuous current ² 108 A for 16 mm ² Pollution degree ¹ 2 Mating cycles min. 10,000	116
		2 contacts for turned contacts with ODU LAMTAC ^{®3} Contact-Ø: 8 mm	 21.6 mm	Maximum current Operating voltage ¹ 400 V Rated surge voltage ¹ 3,000 V Max. continuous current ² 150 A for 25 mm ² Pollution degree ¹ 2 Mating cycles min. 10,000	118
		1 contact for turned contacts with ODU LAMTAC ^{®3} Contact-Ø: 12 mm	 19.2 mm	Operating voltage ¹ 2,500 V Rated surge voltage ¹ 10,000 V Max. continuous current ² 225 A for 50 mm ² Pollution degree ¹ 2 Mating cycles min. 10,000	120

¹According to IEC 60664-1:2007 [VDE 0110-1:2008] for pollution degree 2 ²For a definition of max. continuous current, see page [172](#)

³Contact with lamella technology

OVERVIEW OF ALL MODULES



Modules marked with this symbol can be used in the PUSH-LOCK; note the space requirements.

	Modules	Description	Units/width	Features	Page
Coax		4 contacts for 50 Ω coax contacts	3 Units 7.2 mm	High packing density Frequency range 0–2.8 GHz Mating cycles min. 10,000	122
		2 contacts for 50 Ω coax contacts	5 Units 12 mm	Frequency range 0–4 GHz Mating cycles min. 10,000	124
		2 contacts for 50 Ω coax contacts SMA termination	5 Units 12 mm	Frequency range 0–12 GHz Mating cycles min. 10,000	126
		2 contacts for 75 Ω coax contacts	5 Units 12 mm	Frequency range 0–2.7 GHz Mating cycles min. 10,000	128
Compressed air and fluid coupling		2 contacts	5 Units 12 mm	12 bar Tube-Ø inner-Ø: max. 4 mm outer-Ø Push-in: max. 6 mm Mating cycles min. 10,000	130
		2 contacts	5 Units 12 mm	10 bar Tube-Ø M5 to max. 4 mm Mating cycles min. 10,000	132

OVERVIEW OF ALL MODULES



Modules marked with this symbol can be used in the PUSH-LOCK; note the space requirements.









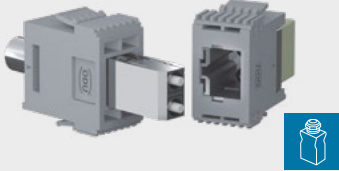

	Modules	Description	Units/width	Features	Page
Compressed air and fluid coupling		2 contacts	 12 mm	10 bar Tube-Ø Mating cycles M5 inside thread min. 10,000	134
		2 contacts	 14.4 mm	Mating cycles min. 10,000 Suitable for all common bus systems CAT 5 ¹ , USB [®] 2.0 ¹	138
Shielded feedthrough/ high-speed connector		1 contact	 14.4 mm	Mating cycles min. 10,000 Suitable for all common bus systems CAT 5 ¹ , USB [®] 2.0 ¹	140
		1 contact RJ45 insert	 16.8 mm	Mating cycles min. 5,000 10 gigabit Ethernet ¹ according to IEEE 802.3 an-2006 CAT 5 ¹ , CAT 6 _A ¹ according to ANSI/TIA IEIA-568-32-10	142
Combination module		2 contacts High-speed & coax	 14.4 mm	Mating cycles min. 10,000 Coax 50 Ω/4 GHz or 75 Ω/2.2 GHz Selected inserts are suitable and qualified for data rates up to 5 Gbit/s. Suitable for USB [®] 2.0 ¹ , USB [®] 3.1 Gen1 ¹ , FireWire [®] 1, Ethernet ¹	144
		2 contacts High-speed & compressed air	 14.4 mm	Mating cycles min. 10,000 Compressed air 12 bar Selected inserts are suitable and qualified for data rates up to 5 Gbit/s. Suitable for USB [®] 2.0 ¹ , USB [®] 3.1 Gen1 ¹ , FireWire [®] 1, Ethernet ¹	146

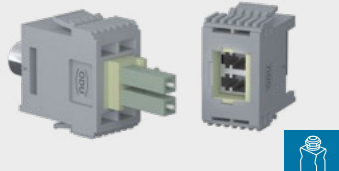
¹Concerning data transmission protocols, please note page 2.

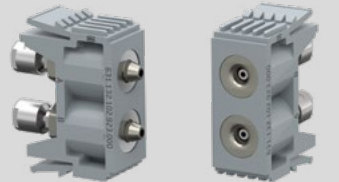
OVERVIEW OF ALL MODULES



Modules marked with this symbol can be used in the PUSH-LOCK; note the space requirements.

	Modules	Description	Units/width	Features	Page
Fiber optic (on request)		2 contacts for SC insert	 16.8 mm	Single mode (SM) Multi mode (MM) Mating cycles min. 5,000	148
		2 contacts for LC insert	 16.8 mm		
		2 contacts for fiber-optic contact for plastic fiber (POF)	 12 mm	Mating cycles Insertion loss typical min. 10,000 1.5 dB for 670 nm	149
Blank modules		Blank modules	 2.4 mm  7.2 mm  12 mm	Used to fill incomplete frames.	150

FOR YOUR NOTES

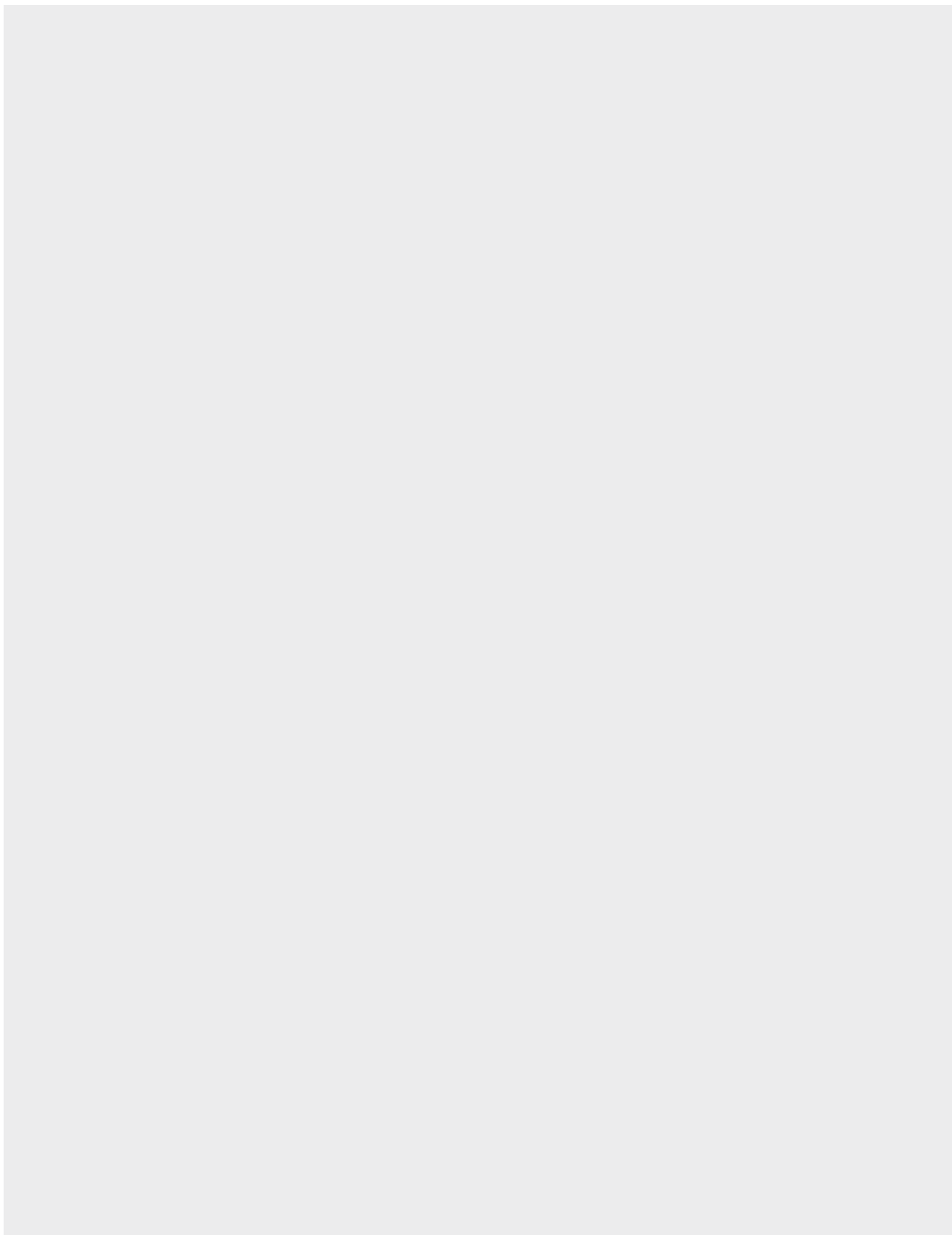

MODULE 20 CONTACTS



Pin protection against mechanical damage

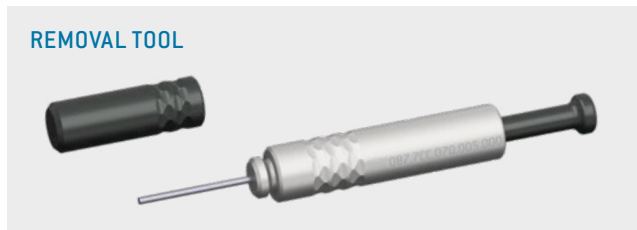

Removal of the assembled contact from the mating side
PART NUMBER: 087.7CC.070.005.000

For an overview of all tools, please see from page [153](#).

Contact diameter: 0.7 mm
Mating cycles: min. 10,000
Current-carrying capacity¹: 11 A

TECHNICAL NOTES

- The current load information is valid for single contacts or fully equipped modules. For use in connector systems, the load should be reduced according to VDE 0298-4:2013 (see page [172](#)).
- For crimp information, see from page [154](#)

TECHNICAL DATA

Voltage data according to IEC 60664-1:2007 (VDE 0110-1:2008)²

Operating voltage	250 V	80 V
Rated surge voltage	2,000 V	2,000 V
Clearance distance	1.0 mm	1.0 mm
Creepage distance	1.0 mm	1.0 mm
Pollution degree	2	3

Voltage data according to standard IEC 61010-1:2010 (VDE 0411-1:2010)³

Supply voltage from grid supply circuit (CAT.2)	150 V < U _{rms} ≤ 300 V	
Operating voltage	200 V	10 V
Test voltage	1,076 V AC	1,076 V AC
Pollution degree	2	3

Voltage data according to MIL⁴

Operating voltage	475 V
Test voltage	1,425 V

Mechanical data

Total mating force (average)	16 N/module
Total sliding force (average)	12 N/module
Contact diameter	0.7 mm
Operating temperature	-40 °C to +125 °C
Mating cycles	min. 10,000

Materials

Insulator	thermoplastic acc. to UL 94
Contact	Cu alloy
Contact finishing	gold-plated

¹ For a definition of max. continuous current, see page [172](#) ² IEC 60664-1:2007 (VDE 0110-1:2008) see page [165](#) ³ See page [168](#) ⁴ See page [169](#)



INSULATOR PIN AND SOCKET

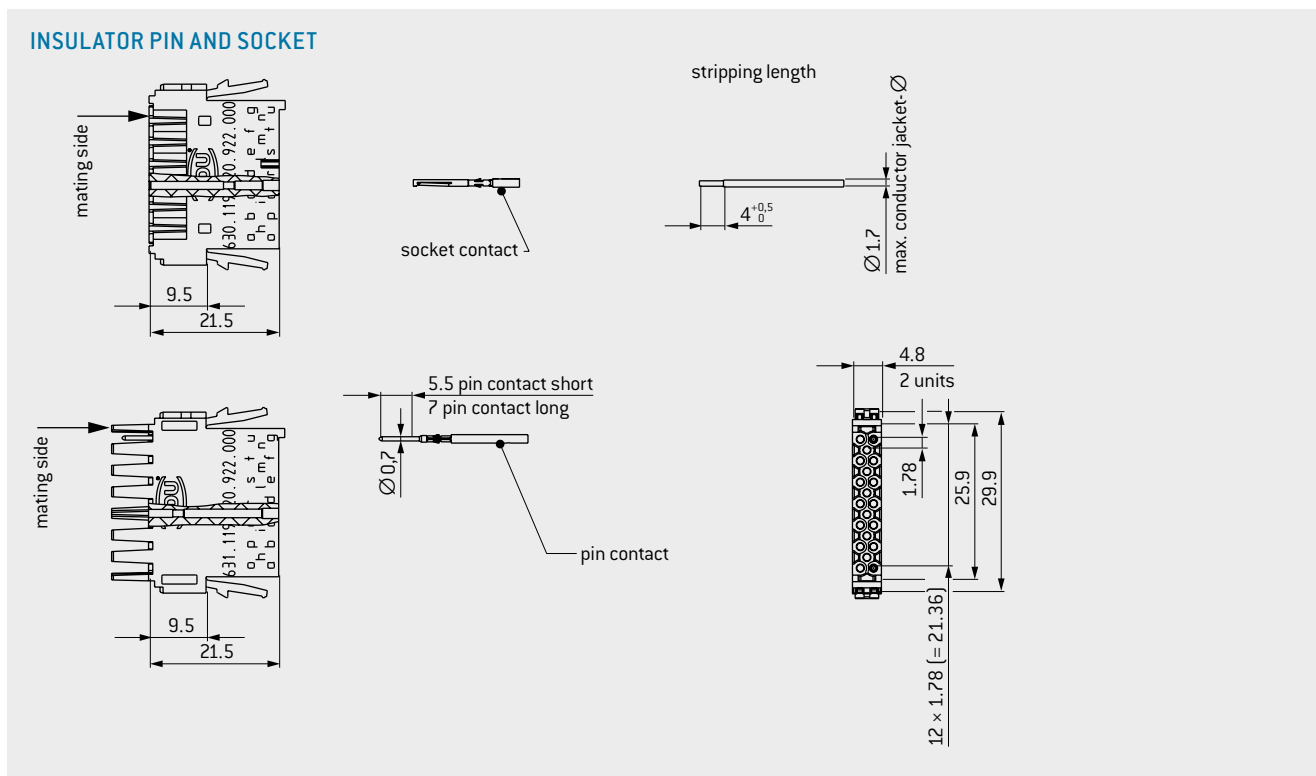

Module 20 contacts	Part number
Insulator socket	630.119.120.922.000
Insulator pin	631.119.120.922.000

Description	Part number	Conductor cross-section mm ²	Termination AWG/mm	Nominal current ¹		Max. continuous current ² Single contact A	Contact resistance mΩ
				Single contact A	Module fully equipped A		
Pin contact short	185.710.000.270.000	0.08–0.38	22–28	7	5.5	11	3.5
Pin contact long	185.711.000.270.000						
Socket contact	175.581.000.270.000						

PCB CONTACTS AVAILABLE ON REQUEST

For suitable PCB termination modules, please see page 106.

¹ Determined according to IEC 60512-5-2:2002 (DIN EN 60512-5-2:2003) at increased temperature 45 K² For a definition of max. continuous current, see page 172

MODULE 10 CONTACTS

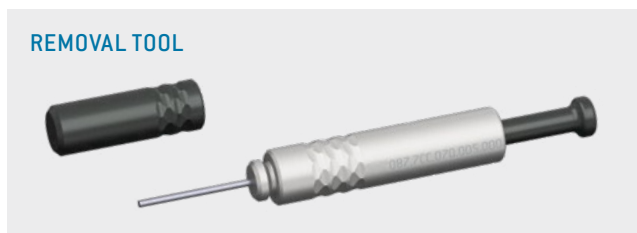
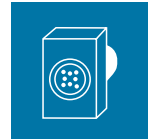

Removal of the assembled contact from the mating side
PART NUMBER: 087.7CC.070.005.000

For an overview of all tools, please see from page [153](#).

Contact diameter: 0.7 mm
Mating cycles: min. 10,000
Current-carrying capacity¹: 11 A

TECHNICAL NOTES

- The current load information is valid for single contacts or fully equipped modules. For use in connector systems, the load should be reduced according to VDE 0298-4:2013 (see page [172](#)).
- For crimp information, see from page [154](#)

TECHNICAL DATA

Voltage data according to IEC 60664-1:2007 (VDE 0110-1:2008)²

Operating voltage	320 V	125 V
Rated surge voltage	2,500 V	2,500 V
Clearance distance	1.4 mm	1.4 mm
Creepage distance	1.6 mm	1.6 mm
Pollution degree	2	3

Voltage data according to standard IEC 61010-1:2010 (VDE 0411-1:2010)³

Supply voltage from grid supply circuit (CAT.2)	150 V U_{rms} ≤ 300 V
---	------------------------------------

Operating voltage	320 V	63 V
Test voltage	1,320 V AC	1,320 V AC
Pollution degree	2	3

Voltage data according to MIL⁴

Operating voltage	475 V
Test voltage	1,425 V

Mechanical data

Total mating force (average)	8 N/module
Total sliding force (average)	6 N/module
Contact diameter	0.7 mm
Operating temperature	-40 °C to +125 °C
Mating cycles	min. 10,000

Materials

Insulator	thermoplastic acc. to UL 94
Contact	Cu alloy
Contact finishing	gold-plated

¹ For a definition of max. continuous current, see page [172](#) ² IEC 60664-1:2007 (VDE 0110-1:2008) see page [165](#) ³ See page [168](#) ⁴ See page [169](#)



INSULATOR PIN AND SOCKET

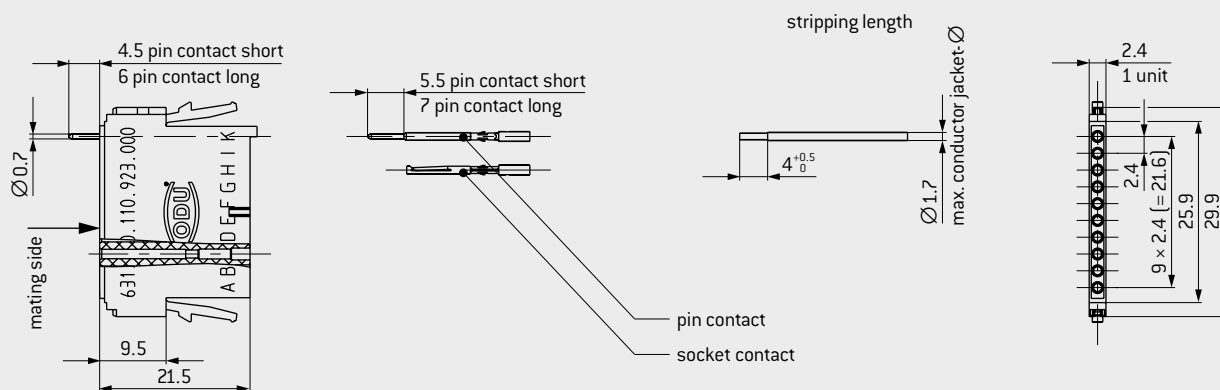

Module 10 contacts	Part number
Insulator socket	630.118.110.922.000
Insulator pin	631.118.110.922.000

Description	Part number	Conductor cross-section mm ²	Termination AWG/mm	Nominal current ¹		Max. continuous current ² Single contact A	Contact resistance mΩ
				Single contact A	Module fully equipped A		
Pin contact short	185.710.000.270.000	0.08–0.38	22–28	7	5.5	11	3.5
Pin contact long	185.711.000.270.000						
Socket contact	175.581.000.270.000						

PCB CONTACTS AVAILABLE ON REQUEST

For suitable PCB termination modules, please see page 108.

¹ Determined according to IEC 60512-5-2:2002 (DIN EN 60512-5-2:2003) at increased temperature 45 K ² For a definition of max. continuous current, see page 172

MODULE 6 CONTACTS

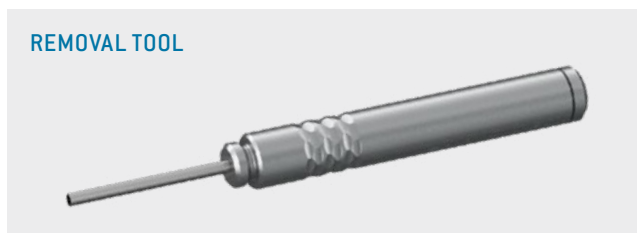
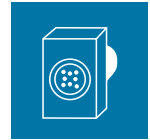

Removal of the assembled contact from the mating side
PART NUMBER: 087.7CC.130.004.000

For an overview of all tools, please see from page [153](#).

Contact diameter: 1.3 mm
Mating cycles: min. 10,000
Current-carrying capacity¹: 19.5 A

TECHNICAL NOTES

- The current load information is valid for single contacts or fully equipped modules. For use in connector systems, the load should be reduced according to VDE 0298-4:2013 [see page [172](#)].
- For crimp information, see from page [154](#)

TECHNICAL DATA

Voltage data according to IEC 60664-1:2007 (VDE 0110-1:2008)²

Operating voltage	400 V	160 V
Rated surge voltage	2,500 V	2,500 V
Clearance distance	2.1 mm	2.1 mm
Creepage distance	2.5 mm	2.5 mm
Pollution degree	2	3

Voltage data according to standard IEC 61010-1:2010 (VDE 0411-1:2010)³

Supply voltage from grid supply circuit (CAT.2)	150 V < U _{rms} ≤ 300 V
---	----------------------------------

Operating voltage	500 V	200 V
Test voltage	1,730 V AC	1,730 V AC
Pollution degree	2	3

Voltage data according to MIL⁴

Operating voltage	775 V
Test voltage	2,325 V

Mechanical data

Total mating force (average)	8.4 N/module
Total sliding force (average)	7.2 N/module
Contact diameter	1.3 mm
Operating temperature	-40 °C to +125 °C
Mating cycles	min. 10,000

Materials

Insulator	thermoplastic acc. to UL 94
Contact	Cu alloy
Contact finishing	gold-plated

¹ For a definition of max. continuous current, see page [172](#) ² IEC 60664-1:2007 (VDE 0110-1:2008) see page [165](#) ³ See page [168](#) ⁴ See page [169](#)



INSULATOR PIN AND SOCKET

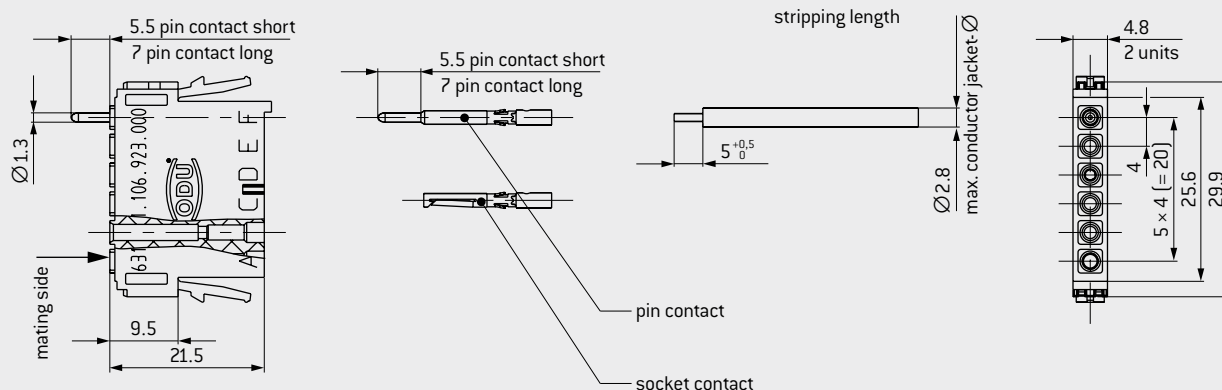

Module 6 contacts	Part number
Insulator	631.111.106.923.000

Description	Part number	Conductor cross-section mm ²	Termination AWG/mm	Nominal current ¹		Max. continuous current ² Single contact A	Contact resistance mΩ
				Single contact A	Module fully equipped A		
Pin contact short	185.432.000.270.000	0.5–1	18–20	12.5	11.5	19.5	1.8
Pin contact long	185.424.000.270.000						
Socket contact	175.535.000.270.000						
Pin contact short	185.714.000.270.000	0.08–0.38	22–28	9.5	7	12	1.8
Pin contact long	185.713.000.270.000						
Socket contact	175.A42.000.270.000						

PCB CONTACTS AVAILABLE ON REQUEST

For suitable PCB termination modules, please see page 110.

¹ Determined according to IEC 60512-5-2:2002 (DIN EN 60512-5-2:2003) at increased temperature 45 K² For a definition of max. continuous current, see page 172

MODULE 5 CONTACTS

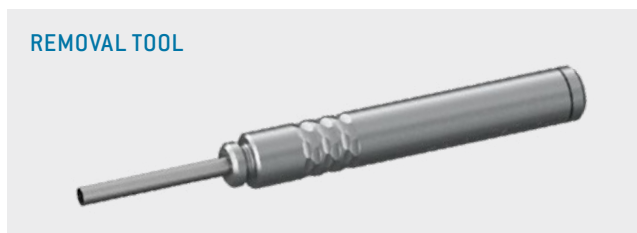
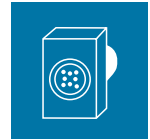

Removal of the assembled contact from the mating side
PART NUMBER: 087.7CC.200.003.000

For an overview of all tools, please see from page [153](#).

Contact diameter: 2 mm
Mating cycles: min. 10,000
Current-carrying capacity¹: 33 A

TECHNICAL NOTES

- The current load information is valid for single contacts or fully equipped modules. For use in connector systems, the load should be reduced according to VDE 0298-4:2013 (see page [172](#)).
- For crimp information, see from page [154](#)

TECHNICAL DATA

Voltage data according to IEC 60664-1:2007 (VDE 0110-1:2008)²

Operating voltage	630 V	250 V
Rated surge voltage	3,000 V	3,000 V
Clearance distance	2.5 mm	2.5 mm
Creepage distance	3.4 mm	3.4 mm
Pollution degree	2	3

Voltage data according to standard IEC 61010-1:2010 (VDE 0411-1:2010)³

Supply voltage from grid supply circuit (CAT.2)	150 V U_{rms} ≤ 300 V	
---	------------------------------------	--

Operating voltage	672 V	267 V
Test voltage	1,959 V AC	1,959 V AC
Pollution degree	2	3

Voltage data according to MIL⁴

Operating voltage	1,025 V
Test voltage	3,075 V

Mechanical data

Total mating force (average)	13.5 N/module
Total sliding force (average)	9 N/module
Contact diameter	2 mm
Operating temperature	-40 °C to +125 °C
Mating cycles	min. 10,000

Materials

Insulator	thermoplastic acc. to UL 94
Contact	Cu alloy
Contact finishing	gold-plated

¹ For a definition of max. continuous current, see page [172](#) ² IEC 60664-1:2007 (VDE 0110-1:2008) see page [165](#) ³ See page [168](#) ⁴ See page [169](#)



INSULATOR PIN AND SOCKET

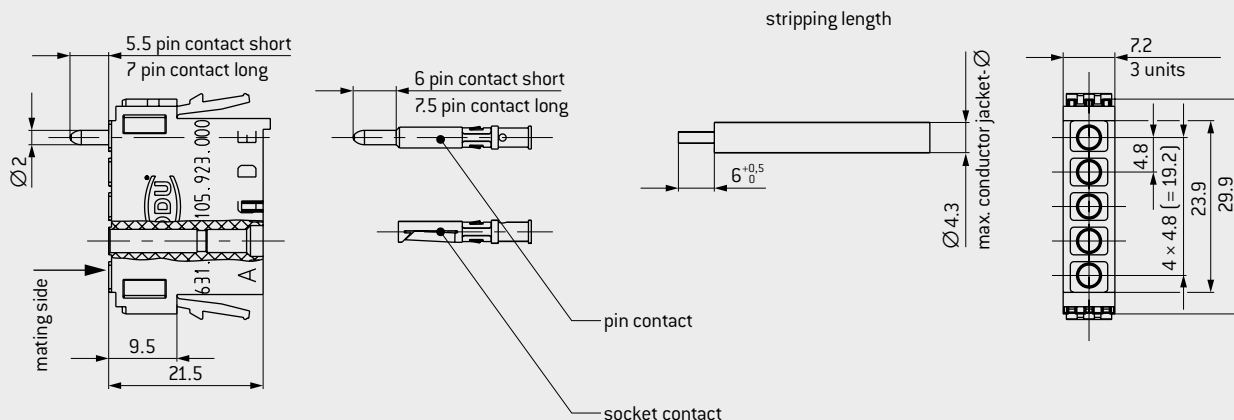

Module 5 contacts	Part number
Insulator	631.112.105.923.000

Description	Part number	Conductor cross-section mm ²	Termination AWG/mm	Nominal current ¹		Max. continuous current ² Single contact A	Contact resistance mΩ
				Single contact A	Module fully equipped A		
Pin contact short	185.437.000.270.000	1–1.5	16 / 18	18	15	27	1
Pin contact long	185.436.000.270.000						
Socket contact	175.567.000.270.000	2.5	14	24	19	33	1
Pin contact short	185.441.000.270.000						
Pin contact long	185.440.000.270.000						
Socket contact	175.570.000.270.000						

PCB CONTACTS AVAILABLE ON REQUEST

For suitable PCB termination modules, please see page 112.

¹ Determined according to IEC 60512-5-2:2002 (DIN EN 60512-5-2:2003) at increased temperature 45 K² For a definition of max. continuous current, see page 172

MODULE 20 CONTACTS

For effective PCB contacting with quick-change function

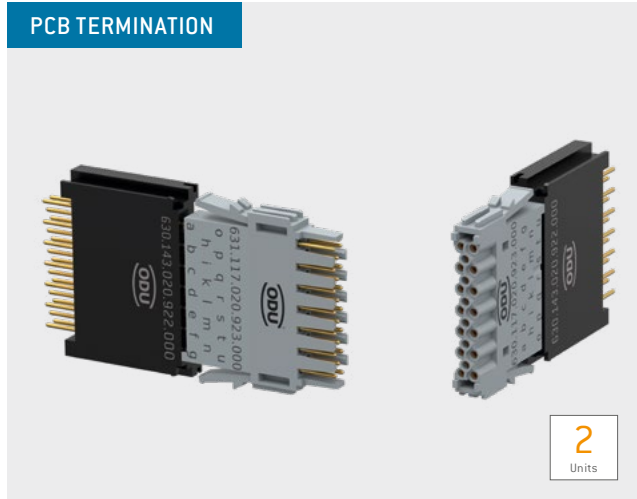
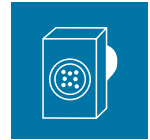

COMPATIBLE WITH MODULE 20 CONTACTS ON PAGE [98](#)

NOTE

- Frame for the transfer of grounding to the board and corresponding grounding socket on request
- Explanations of the structure on page [38](#).

Contact diameter: 0.7 mm
Mating cycles: min. 10,000
Current-carrying capacity¹: 7 A

TECHNICAL NOTES

- The current load information is valid for single contacts or fully equipped modules. For use in connector systems, the load should be reduced according to VDE 0298-4:2013 (see page [175](#)).
- Solder temperature for PCB termination module (black PA) 260 °C for 30 seconds
- Maximum adjacent arrangement of 10 modules

TECHNICAL DATA

Voltage data according to IEC 60664-1:2007 (VDE 0110-1:2008)²

Operating voltage	250 V	50 V
Rated surge voltage	2,500 V	2,500 V
Clearance distance	1.0 mm	1.0 mm
Creepage distance	1.0 mm	1.0 mm
Pollution degree	2	3

Voltage data according to standard IEC 61010-1:2010 (VDE 0411-1:2010)³

Supply voltage from grid supply circuit (CAT.2)	150 V < U _{rms} ≤ 300 V	
Operating voltage	200 V	10 V
Test voltage	1,076 V AC	1,076 V AC
Pollution degree	2	3

Voltage data according to MIL⁴

Operating voltage	475 V
Test voltage	1,425 V

Mechanical data

Total mating force (average)	16 N/module
Total sliding force (average)	12 N/module
Contact diameter	0.7 mm
Operating temperature	-40 °C to +125 °C
Mating cycles	min. 10,000

Materials

Insulator pin/socket frame	thermoplastic acc. to UL 94 (Gray)
Insulator PCB	thermoplastic acc. to UL 94 (Black)
Contact body	Cu alloy
Contact finishing	gold-plated

¹ For a definition of max. continuous current, see page [172](#) ² See page [165](#) ³ See page [168](#) ⁴ See page [169](#)

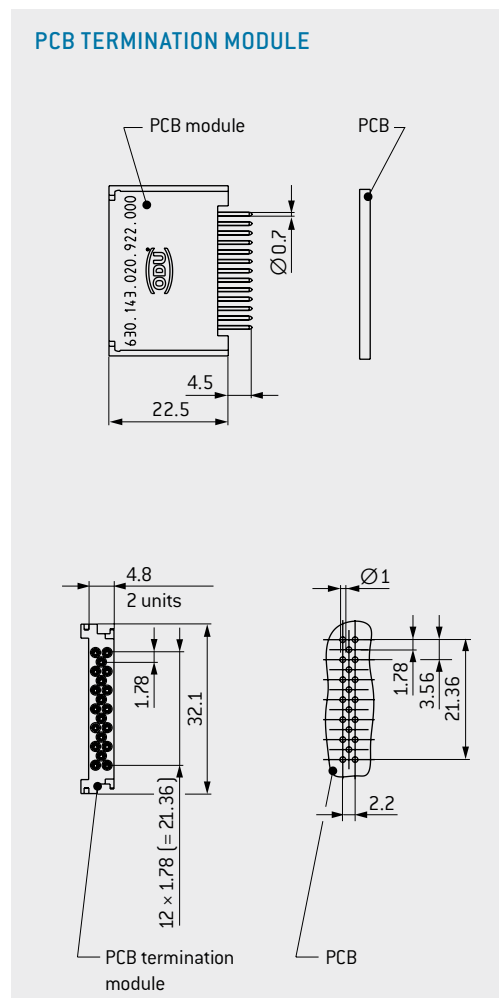
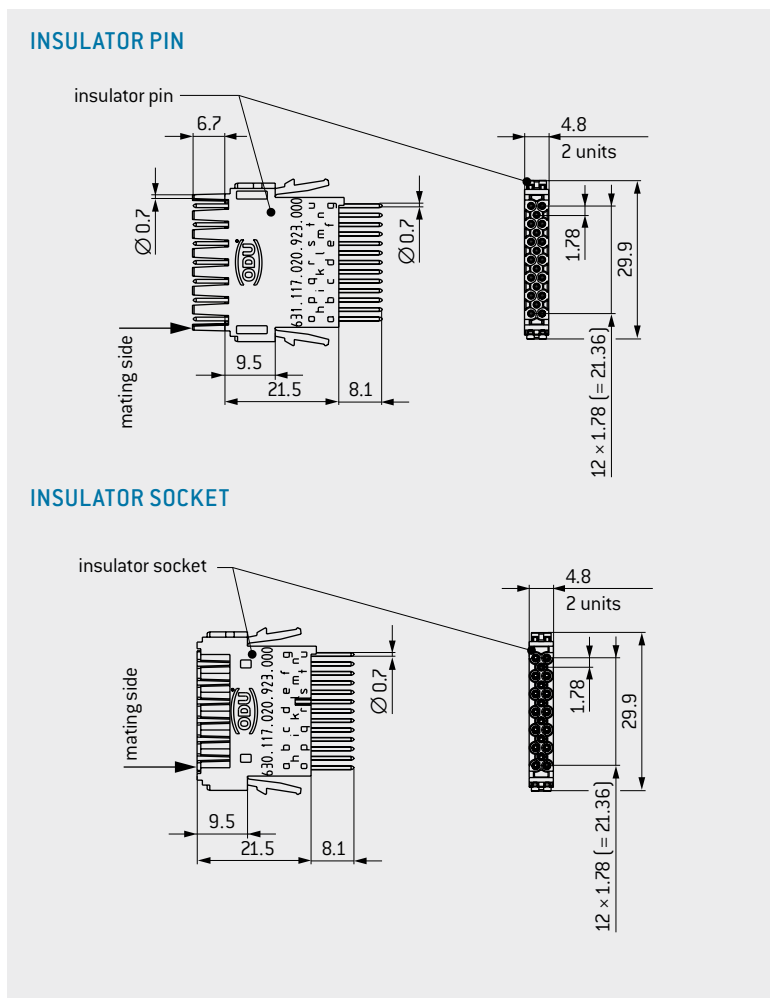

Description	Part number	Nominal current ¹	Max. continuous current ²	Contact resistance ³
		A	A	mΩ
Insulator socket incl. contacts	630.117.020.923.000	4.5	7	7
Insulator pin incl. contacts	631.117.020.923.000	4.5	7	7
Insulator PCB incl. injected contacts ⁴	630.143.020.922.000	4.5	7	7

¹ Determined according to IEC 60512-5-2:2002 (DIN EN 60512-5-2:2003) at increased temperature 45 K² For a definition of max. continuous current, see page 172
³ Due to the double transfer between the modules and the PCB termination modules, the contact resistance is twice as high as with a normal signal module.

⁴ PCB contacts are injected in the insulator, so cannot be removed

MODULE 10 CONTACTS

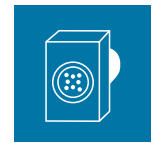

For effective PCB contacting with quick-change function

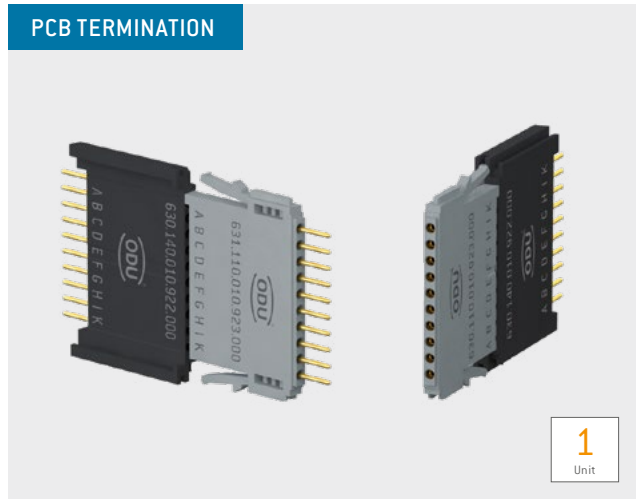

COMPATIBLE WITH MODULE 10 CONTACTS ON PAGE [100](#)

NOTE

- Frame for the transfer of grounding to the board and corresponding grounding socket on request
- Explanations of the structure on page [38](#).

Contact diameter: 0.7 mm
Mating cycles: min. 10,000
Current-carrying capacity¹: 7 A

TECHNICAL NOTES

- The current load information is valid for single contacts or fully equipped modules. For use in connector systems, the load should be reduced according to VDE 0298-4:2013 (see page [175](#)).
- Solder temperature for PCB termination module (black PA) 260 °C for 30 seconds
- Maximum adjacent arrangement of 10 modules

TECHNICAL DATA

Voltage data according to IEC 60664-1:2007 (VDE 0110-1:2008)²

Operating voltage	320 V	80 V
Rated surge voltage	2,500 V	2,500 V
Clearance distance	1.4 mm	1.4 mm
Creepage distance	1.6 mm	1.6 mm
Pollution degree	2	3

Voltage data according to standard IEC 61010-1:2010 (VDE 0411-1:2010)³

Supply voltage from grid supply circuit (CAT.2) $150 \text{ V} < U_{\text{rms}} \leq 300 \text{ V}$

Operating voltage	320 V	63 V
Test voltage	1,320 V AC	1,320 V AC
Pollution degree	2	3

Voltage data according to MIL⁴

Operating voltage	475 V
Test voltage	1,425 V

Mechanical data

Total mating force (average)	8 N/module
Total sliding force (average)	6 N/module
Contact diameter	0.7 mm
Operating temperature	-40 °C to +125 °C
Mating cycles	min. 10,000

Materials

Insulator pin/socket frame	thermoplastic acc. to UL 94 (Gray)
Insulator PCB	thermoplastic acc. to UL 94 (Black)
Contact body	Cu alloy
Contact finishing	gold-plated

¹For a definition of max. continuous current, see page [172](#) ²IEC 60664-1:2007 (VDE 0110-1:2008) see page [165](#) ³See page [168](#) ⁴See page [169](#)



INSULATOR PIN

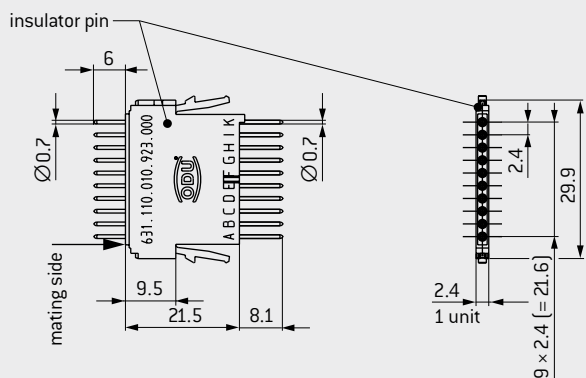

INSULATOR SOCKET

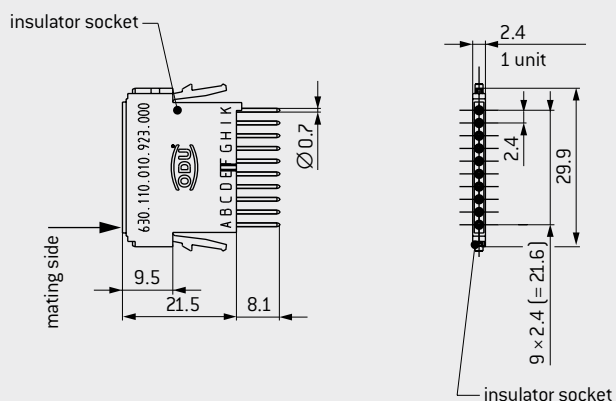

PCB TERMINATION MODULE

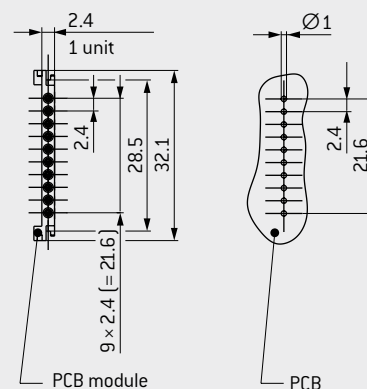
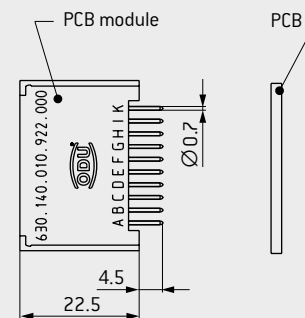

Description	Part number	Nominal current ¹	Max. continuous current ²	Contact resistance ³
		A	A	mΩ
Insulator socket incl. contacts	630.110.010.923.000	4.5	7	7
Insulator pin incl. contacts	631.110.010.923.000	4.5	7	7
Insulator PCB incl. injected contacts ⁴	630.140.010.922.000	4.5	7	7

¹ Determined according to IEC 60512-5-2:2002 (DIN EN 60512-5-2:2003) at increased temperature 45 K² For a definition of max. continuous current, see page 172

³ Due to the double transfer between the modules and the PCB termination modules, the contact resistance is twice as high as with a normal signal module.

⁴ PCB contacts are injected in the insulator, so cannot be removed

MODULE 6 CONTACTS

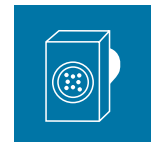

For effective PCB contacting with quick-change function

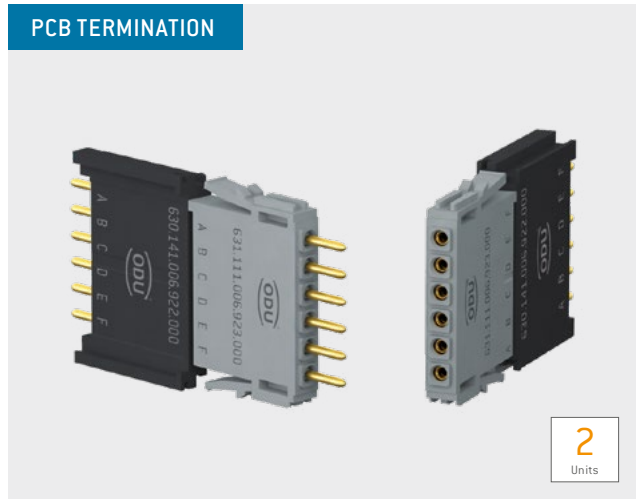

Contact diameter: 1.3 mm
Mating cycles: min. 10,000
Current-carrying capacity¹: 13 A

TECHNICAL NOTES

- The current load information is valid for single contacts or fully equipped modules. For use in connector systems, the load should be reduced according to VDE 0298-4:2013 [see page 175].
- Solder temperature for PCB termination module (black PA) 260 °C for 30 seconds
- Maximum adjacent arrangement of 10 modules

TECHNICAL DATA

Voltage data according to IEC 60664-1:2007 (VDE 0110-1:2008)²

Operating voltage	400 V	160 V
Rated surge voltage	2,500 V	2,500 V
Clearance distance	2.1 mm	2.1 mm
Creepage distance	2.5 mm	2.5 mm
Pollution degree	2	3

Voltage data according to standard IEC 61010-1:2010 (VDE 0411-1:2010)³

Supply voltage from grid supply circuit (CAT.2)	150 V U_{rms} ≤ 300 V	
Operating voltage	500 V	200 V
Test voltage	1,730 V AC	1,730 V AC
Pollution degree	2	3

Voltage data according to MIL⁴

Operating voltage	775 V
Test voltage	2,325 V

Mechanical data

Total mating force (average)	8.4 N/module
Total sliding force (average)	7.2 N/module
Contact diameter	1.3 mm
Operating temperature	-40 °C to +125 °C
Mating cycles	min. 10,000

Materials

Insulator pin/socket frame	thermoplastic acc. to UL 94 (Gray)
Insulator PCB	thermoplastic acc. to UL 94 (Black)
Contact body	Cu alloy
Contact finishing	gold-plated

COMPATIBLE WITH MODULE 6 CONTACTS ON PAGE 102

NOTE

- Frame for the transfer of grounding to the board and corresponding grounding socket on request
- Explanations of the structure on page 38.

¹ For a definition of max. continuous current, see page 172 ² IEC 60664-1:2007 (VDE 0110-1:2008) see page 165. ³ See page 168 ⁴ See page 169



INSULATOR PIN

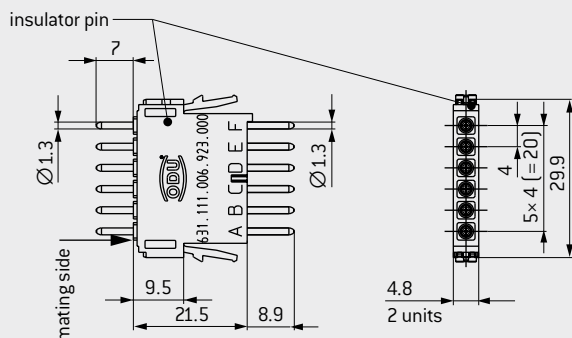

INSULATOR SOCKET

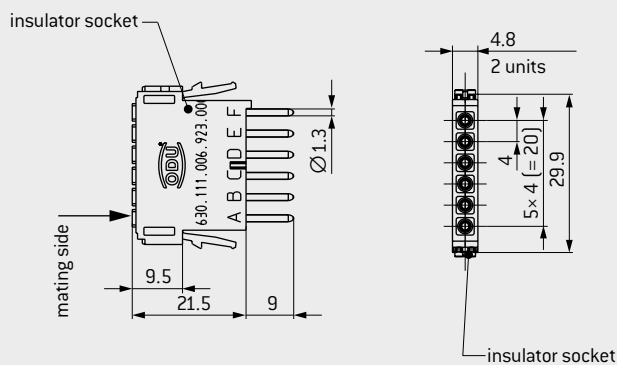

PCB TERMINATION MODULE

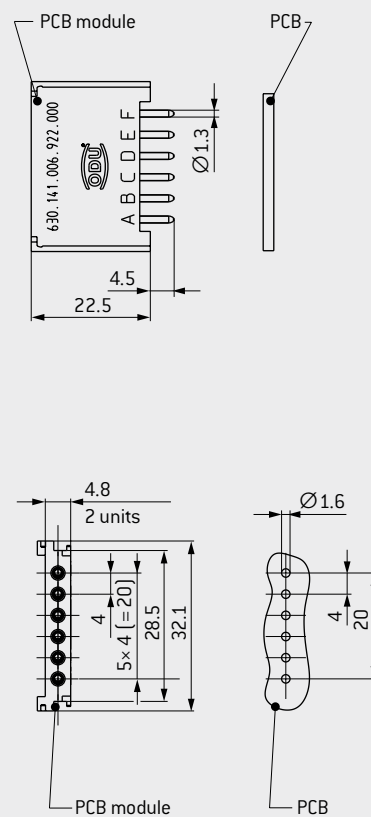

Description	Part number	Nominal current ¹	Max. continuous current ²	Contact resistance ³
		A	A	mΩ
Insulator socket incl. contacts	630.111.006.923.000	8	13	3.6
Insulator pin incl. contacts	631.111.006.923.000	8	13	3.6
Insulator PCB incl. injected contacts ⁴	630.141.006.922.000	8	13	3.6

¹ Determined according to IEC 60512-5-2:2002 (DIN EN 60512-5-2:2003) at increased temperature 45 K² For a definition of max. continuous current, see page 172

³ Due to the double transfer between the modules and the PCB termination modules, the contact resistance is twice as high as with a normal signal module.

⁴ PCB contacts are injected in the insulator, so cannot be removed

MODULE 5 CONTACTS

For effective PCB contacting with quick-change function

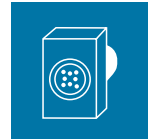

COMPATIBLE WITH MODULE 5 CONTACTS ON PAGE [104](#)

NOTE

- Frame for the transfer of grounding to the board and corresponding grounding socket on request
- Explanations of the structure on page [38](#).

Contact diameter: 2 mm
Mating cycles: min. 10,000
Current-carrying capacity¹: 25 A

TECHNICAL NOTES

- The current load information is valid for single contacts or fully equipped modules. For use in connector systems, the load should be reduced according to VDE 0298-4:2013 [see page [175](#)].
- Solder temperature for PCB termination module (black PA) 260 °C for 30 seconds
- Maximum adjacent arrangement of 10 modules

TECHNICAL DATA

Voltage data according to IEC 60664-1:2007 (VDE 0110-1:2008)²

Operating voltage	630 V	250 V
Rated surge voltage	3,000 V	3,000 V
Clearance distance	2.5 mm	2.5 mm
Creepage distance	3.4 mm	3.4 mm
Pollution degree	2	3

Voltage data according to standard IEC 61010-1:2010 (VDE 0411-1:2010)³

Supply voltage from grid supply circuit (CAT.2)	150 V < U _{rms} ≤ 300 V	
Operating voltage	672 V	267 V
Test voltage	1,959 V AC	1,959 V AC
Pollution degree	2	3

Voltage data according to MIL⁴

Operating voltage	1,025 V
Test voltage	3,075 V

Mechanical data

Total mating force (average)	13.5 N/module
Total sliding force (average)	9 N/module
Contact diameter	2 mm
Operating temperature	-40 °C to +125 °C
Mating cycles	min. 10,000

Materials

Insulator pin/socket frame	thermoplastic acc. to UL 94 (Gray)
Insulator PCB	thermoplastic acc. to UL 94 (Black)
Contact body	Cu alloy
Contact finishing	gold-plated

¹ For a definition of max. continuous current, see page [172](#) ² IEC 60664-1:2007 (VDE 0110-1:2008) see page [165](#) ³ See page [168](#) ⁴ See page [169](#)



INSULATOR PIN

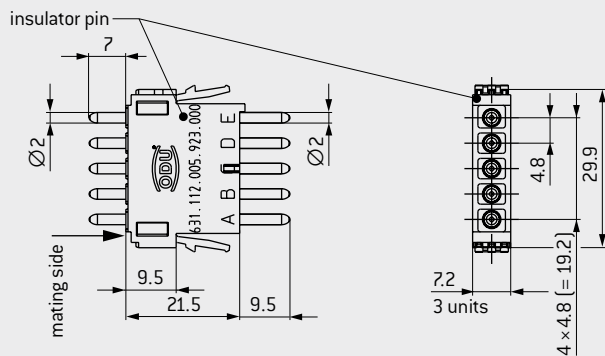

INSULATOR SOCKET

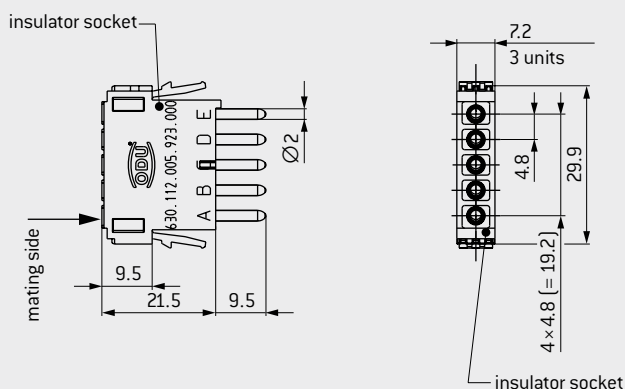

PCB TERMINATION MODULE

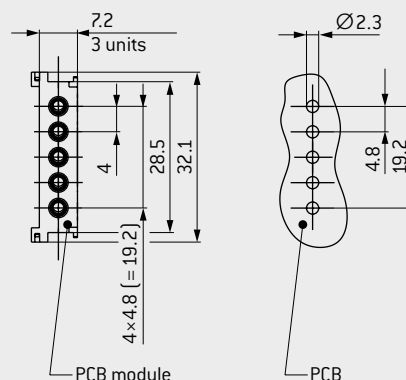
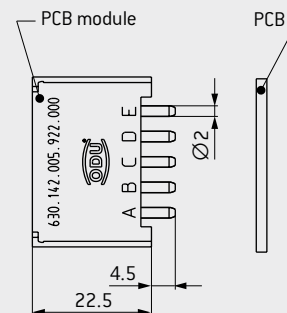

Description	Part number	Nominal current ¹	Max. continuous current ²	Contact resistance ³
		A	A	mΩ
Insulator socket incl. contacts	630.112.005.923.000	16	25	2
Insulator pin incl. contacts	631.112.005.923.000	16	25	2
Insulator PCB incl. injected contacts ⁴	630.142.005.922.000	16	25	2

¹ Determined according to IEC 60512-5-2:2002 (DIN EN 60512-5-2:2003) at increased temperature 45 K² For a definition of max. continuous current, see page 172

³ Due to the double transfer between the modules and the PCB termination modules, the contact resistance is twice as high as with a normal signal module.

⁴ PCB contacts are injected in the insulator, so cannot be removed

MODULE 3 CONTACTS

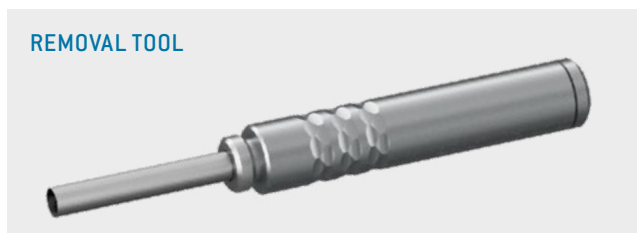
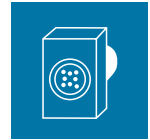

Removal of the assembled contact from the mating side
PART NUMBER: 087.7CC.350.001.000

For an overview of all tools, please see from page [153](#).

Contact diameter: 3.5 mm
Mating cycles: min. 10,000
Current-carrying capacity¹: 58 A

TECHNICAL NOTES

- The current load information is valid for single contacts or fully equipped modules. For use in connector systems, the load should be reduced according to VDE 0298-4:2013 (see page [172](#)).
- For crimp information, see from page [154](#)

TECHNICAL DATA

Voltage data according to IEC 60664-1:2007 (VDE 0110-1:2008)²

Operating voltage	2,500 V	1,000 V
Rated surge voltage	10 KV	8 KV
Clearance distance	16.3 mm	16.3 mm
Creepage distance	16.3 mm	16.3 mm
Pollution degree	2	3

Voltage data according to standard IEC 61010-1:2010 (VDE 0411-1:2010)³

Supply voltage from grid supply circuit (CAT.2)	150 V U_{rms} ≤ 300 V
---	------------------------------------

Operating voltage	3,260 V	1,276 V
Test voltage	7,514 V AC	7,514 V AC
Pollution degree	2	3

Voltage data according to MIL⁴

Operating voltage	3,750 V
Test voltage	11,250 V

Mechanical data

Total mating force (average)	12 N/module
Total sliding force (average)	10 N/module
Contact diameter	3.5 mm
Operating temperature	-40 °C to +125 °C
Mating cycles	min. 10,000

Materials

Insulator	thermoplastic acc. to UL 94
Contact	Cu alloy
Contact finishing	gold-plated

¹ For a definition of max. continuous current, see page [172](#) ² IEC 60664-1:2007 (VDE 0110-1:2008) see page [165](#) ³ See page [168](#) ⁴ See page [169](#)



INSULATOR PIN AND SOCKET

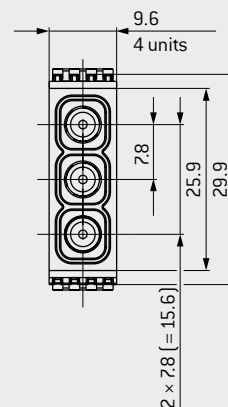
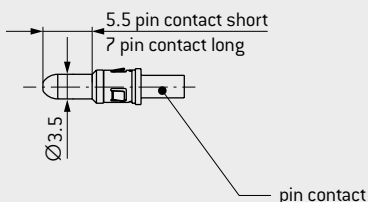
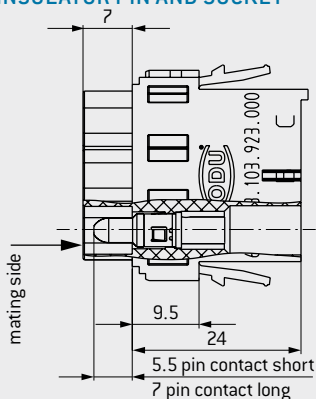

INSULATOR SOCKET

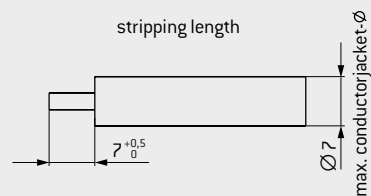
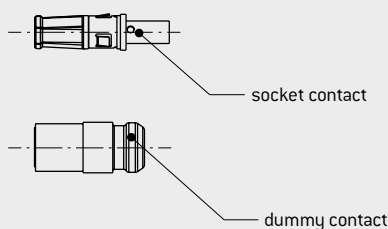
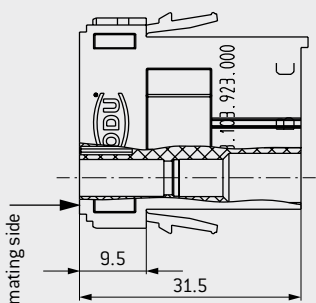

Recommended dummy contact disassembling tools:
Ø3 mm – 4.5 mm

Module 3 contacts	Part number
Insulator socket	630.113.103.923.000
Insulator pin	631.113.103.923.000
Dummy contact	021.341.201.946.000

Description	Part number	Conductor cross-section mm ²	Termination AWG/mm	Nominal current ¹		Max. continuous current ² Single contact A	Contact resistance mΩ
				Single contact A	Module fully equipped A		
Pin contact short	185.463.000.270.000	2.5	14	25	21	37	0.4
Pin contact long	185.462.000.270.000						
Socket contact	177.060.000.270.000						
Pin contact short	185.461.000.270.000	4	12	39	30	58	0.4
Pin contact long	185.460.000.270.000						
Socket contact	177.059.000.270.000						
Pin contact short	185.443.000.270.000	6	10	39	30	58	0.4
Pin contact long	185.442.000.270.000						
Socket contact	177.058.000.270.000						

¹ Determined according to IEC 60512-5-2:2002 (DIN EN 60512-5-2:2003) at increased temperature 45 K² For a definition of max. continuous current, see page 172

MODULE 2 CONTACTS

ODU LAMTAC® (contact with lamella technology)



HIGH CURRENT

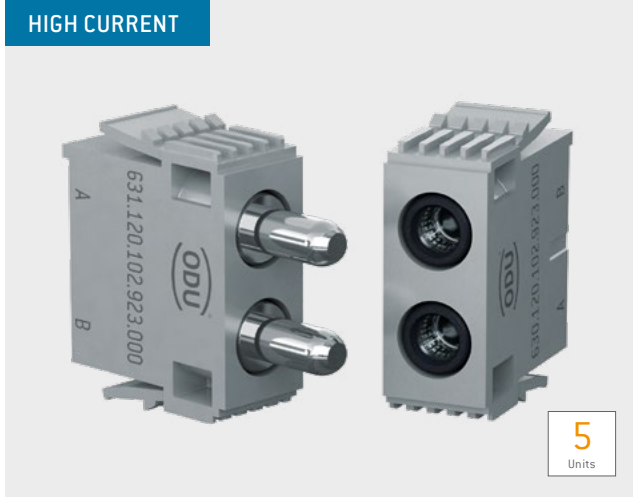

REMOVAL TOOL

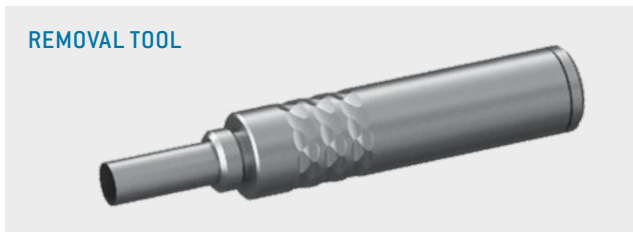

Removal of the assembled contact from the mating side
PART NUMBER: 087.7CC.680.001.000

For an overview of all tools, please see from page [153](#).

Contact diameter: 5 mm
Mating cycles: min. 10,000
Current-carrying capacity¹: 108 A

TECHNICAL NOTES

- The current load information is valid for single contacts or fully equipped modules. For use in connector systems, the load should be reduced according to VDE 0298-4:2013 [see page [172](#)].
- For crimp information, see from page [154](#)

TECHNICAL DATA

Voltage data according to IEC 60664-1:2007 (VDE 0110-1:2008)²

Operating voltage	400 V	160 V
Rated surge voltage	4 kV	3 kV
Clearance distance	3.1 mm	3.1 mm
Creepage distance	3.1 mm	3.1 mm
Pollution degree	2	3

Voltage data according to standard

IEC 61010-1:2010 (VDE 0411-1:2010)³

Supply voltage from grid supply circuit (CAT.2) $150 \text{ V} < U_{\text{rms}} \leq 300 \text{ V}$

Operating voltage	611 V	485 V
Test voltage	2,251 V AC	2,251 V AC
Pollution degree	2	3

Voltage data according to MIL⁴

Operating voltage	975 V
Test voltage	2,925 V

Mechanical data

Total mating force (average)	34 N/module
Total sliding force (average)	28 N/module
Contact diameter	5 mm
Operating temperature	-40 °C to +125 °C
Mating cycles	min. 10,000

Materials

Insulator	thermoplastic acc. to UL 94
Contact body	Cu alloy
Contact lamella	CuBe alloy
Contact finishing	silver-plated

¹ For a definition of max. continuous current, see page [172](#) ² IEC 60664-1:2007 (VDE 0110-1:2008) see page [165](#) ³ See page [168](#) ⁴ See page [169](#)



INSULATOR PIN AND SOCKET

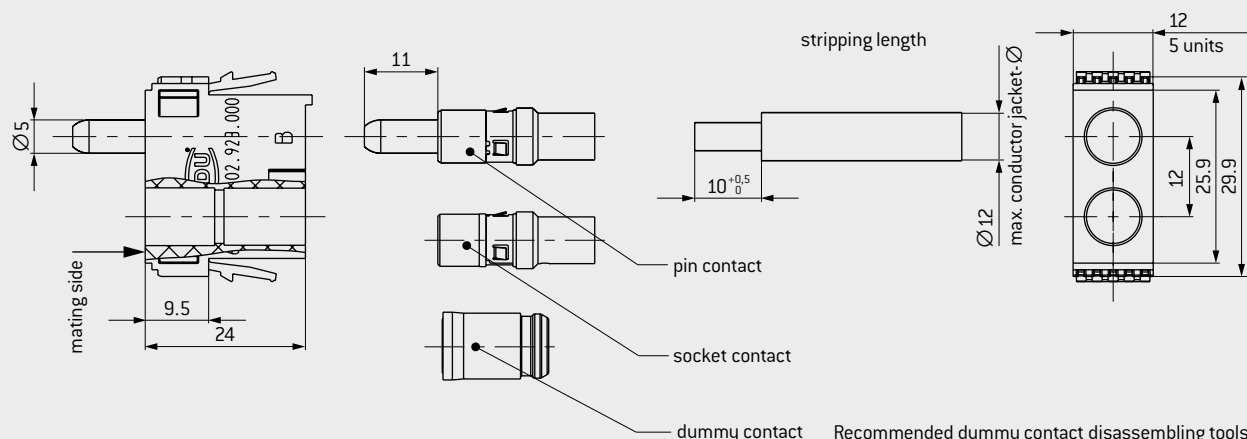

For use in a housing, check the necessary space requirements

ODU LAMTAC® (CONTACT WITH LAMELLA TECHNOLOGY)

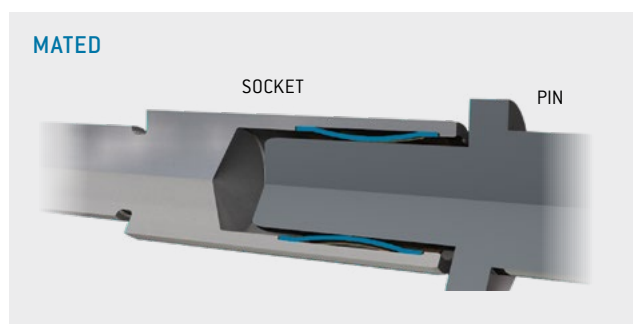
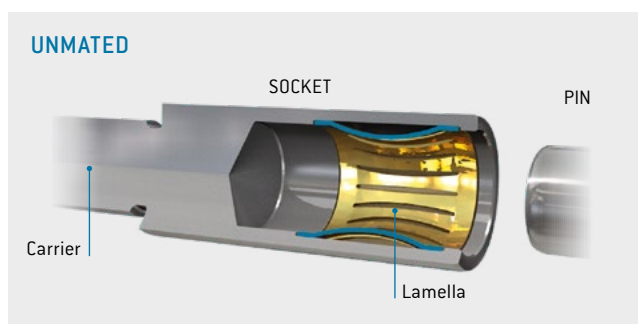

Module 2 contacts	Part number
Insulator	631.120.102.923.000
Dummy contact	021.341.202.946.000

Description	Part number	Conductor cross-section mm ²	Nominal current ¹		Max. continuous current ² Single contact A	Contact resistance mΩ
			Single contact A	Module fully equipped A		
Pin contact	185.484.000.201.000	10	56	56	90	0.2
Socket contact	178.879.100.201.000					
Pin contact	185.485.000.201.000	16	68	68	108	0.2
Socket contact	178.880.100.201.000					

¹ Determined according to IEC 60512-5-2:2002 (DIN EN 60512-5-2:2003) at increased temperature 45 K² For a definition of max. continuous current, see page 172

MODULE 2 CONTACTS

ODU LAMTAC® (contact with lamella technology)

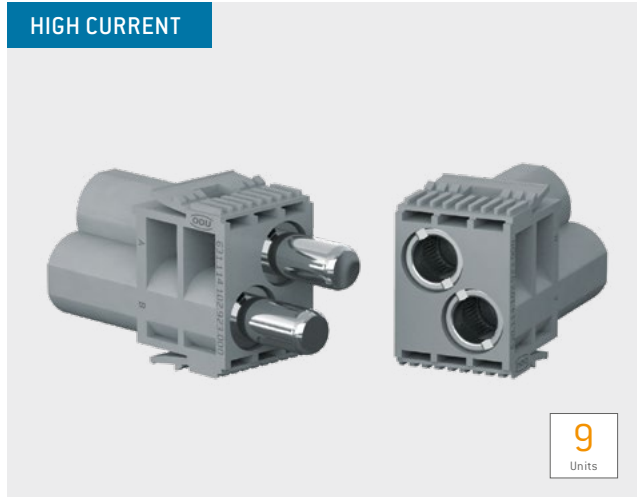
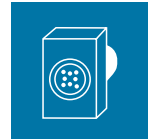

Tightening torque 2.7 Nm ± 0.1 Nm
PART NUMBER: 087.611.002.001.000

For an overview of all tools, please see from page [153](#).

Contact diameter: 8 mm
Mating cycles: min. 10,000
Current-carrying capacity¹: 150 A

TECHNICAL NOTES

- The current load information is valid for single contacts or fully equipped modules. For use in connector systems, the load should be reduced according to VDE 0298-4:2013 [see page [172](#)].
- For crimp information, see from page [154](#)

TECHNICAL DATA

Voltage data according to IEC 60664-1:2007 (VDE 0110-1:2008)²

Operating voltage	400 V	160 V
Rated surge voltage	3 kV	3 kV
Clearance distance	2.3 mm	2.3 mm
Creepage distance	2.4 mm	2.4 mm
Pollution degree	2	3

Voltage data according to standard IEC 61010-1:2010 (VDE 0411-1:2010)³

Supply voltage from grid supply circuit (CAT.2)	150 V < U _{rms} ≤ 300 V
---	----------------------------------

Operating voltage	537 V	428 V
Test voltage	1,844 V AC	1,844 V AC
Pollution degree	2	3

Voltage data according to MIL⁴

Operating voltage	700 V
Test voltage	2,100 V

Mechanical data

Total mating force (average)	60 N/module
Total sliding force (average)	45 N/module
Contact diameter	8 mm
Operating temperature	-40 °C to +125 °C
Mating cycles	min. 10,000

Materials

Insulator	thermoplastic acc. to UL 94
Contact body	Cu alloy
Contact lamella	CuBe alloy
Contact finishing	silver-plated

¹ For a definition of max. continuous current, see page [172](#) ² IEC 60664-1:2007 (VDE 0110-1:2008) see page [165](#) ³ See page [168](#) ⁴ See page [169](#)

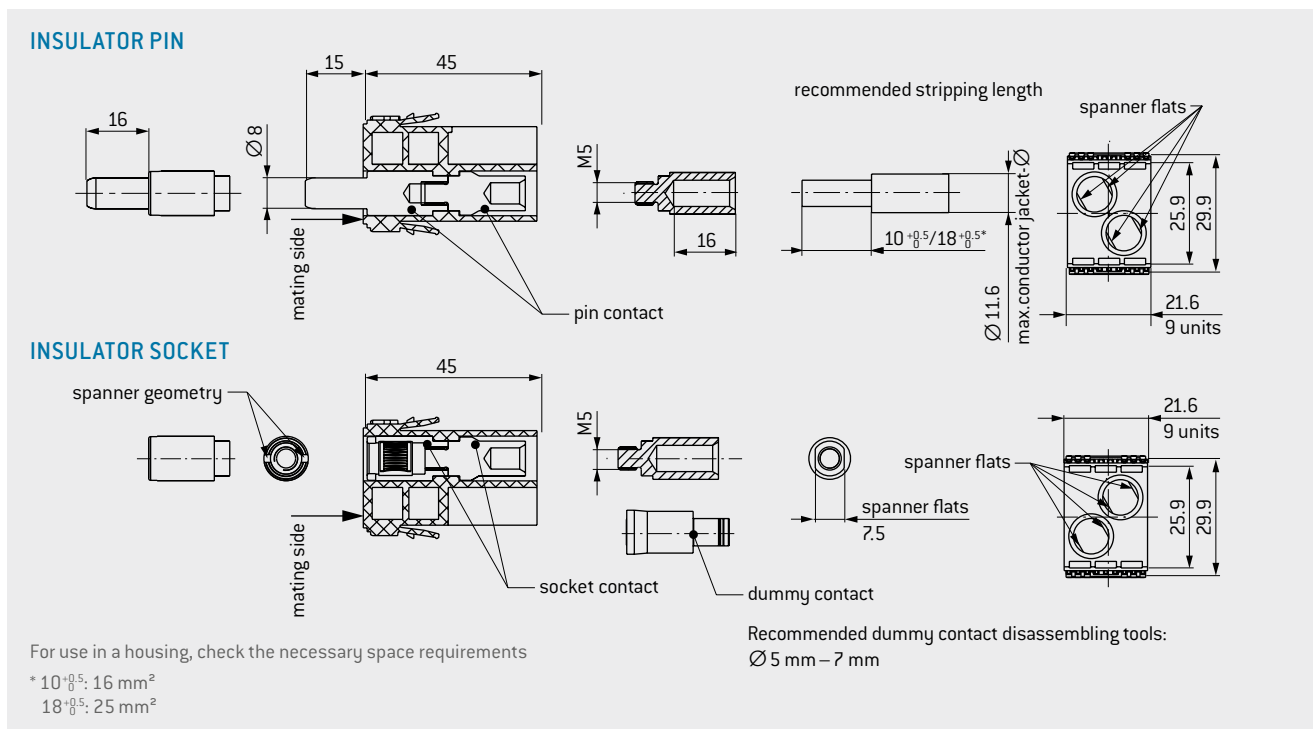

ODU LAMTAC® (CONTACT WITH LAMELLA TECHNOLOGY)

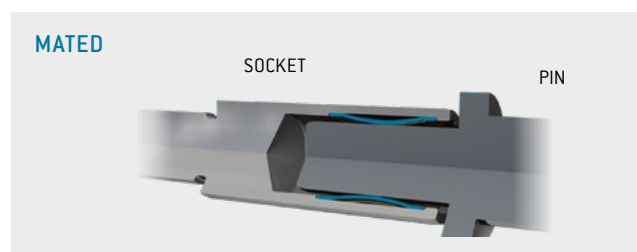
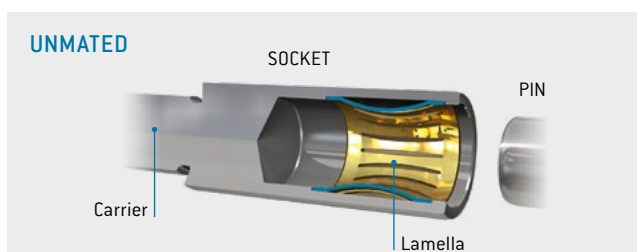

Module 2 contacts	Part number
Insulator socket	630.114.102.923.000
Insulator pin	631.114.102.923.000
Dummy contact	021.341.203.946.000

Description	Part number	Conductor cross-section mm ²	Nominal current ¹		Max. continuous current ² Single contact A	Contact resistance mΩ
			Single contact A	Module fully equipped A		
Pin contact	181.875.100.200.000	16	76	75	123	0.2
Socket contact	178.875.100.201.000					
Pin contact	181.874.100.200.000	25	103	100	150	0.2
Socket contact	178.874.100.201.000					

¹ Determined according to IEC 60512-5-2:2002 [DIN EN 60512-5-2:2003] at increased temperature 45 K² For a definition of max. continuous current, see page 172

MODULE 1 CONTACT

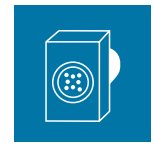

ODU LAMTAC® (contact with lamella technology)

HIGH CURRENT

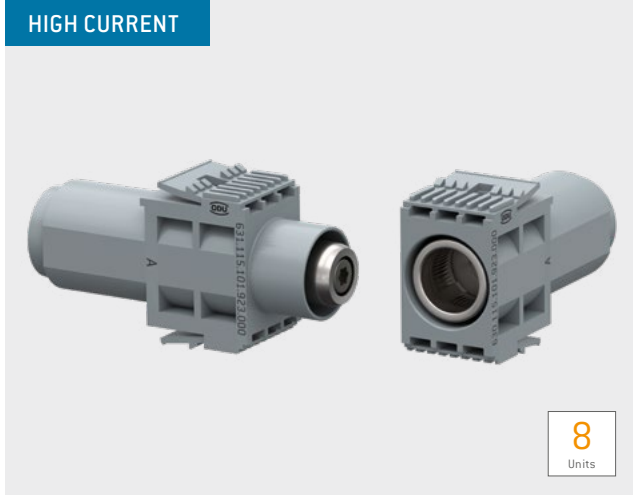

8

Units

REQUIRED ASSEMBLY TOOL

For screwing and releasing the contacts.



Tightening torque 2.2 Nm ± 0.2 Nm

PART NUMBER: 598.054.006.000.000

Torx bit TX20

PART NUMBER: 598.054.105.000.00

For an overview of all tools, please see from page [153](#).

Contact diameter: 12 mm
Mating cycles: min. 10,000
Current-carrying capacity¹: 225 A

TECHNICAL NOTES

- The current load information is valid for single contacts or fully equipped modules. For use in connector systems, the load should be reduced according to VDE 0298-4:2013 [see page [172](#)].
- For crimp information, see from page [154](#)

TECHNICAL DATA

Voltage data according to IEC 60664-1:2007 (VDE 0110-1:2008)²

Operating voltage	2,500 V	1,000 V
Rated surge voltage	10 KV	10 KV
Clearance distance	13.5 mm	13.5 mm
Creepage distance	13.5 mm	13.5 mm
Pollution degree	2	3

Voltage data according to standard IEC 61010-1:2010 (VDE 0411-1:2010)³

Supply voltage from grid supply circuit (CAT.2)	150 V < U _{rms} ≤ 300 V	
Operating voltage	2,700 V	1,071 V
Test voltage	6,388 V AC	6,388 V AC
Pollution degree	2	3

Voltage data according to MIL⁴

Operating voltage	850 V
Test voltage	2,550 V

Mechanical data

Total mating force (average)	45 N/module
Total sliding force (average)	30 N/module
Contact diameter	12 mm
Operating temperature	-40 °C to +125 °C
Mating cycles	min. 10,000

Materials

Insulator	thermoplastic acc. to UL 94
Contact body	Cu alloy
Contact lamella	CuBe alloy
Contact finishing	silver-plated

¹ For a definition of max. continuous current, see page [172](#) ² IEC 60664-1:2007 (VDE 0110-1:2008) see page [165](#) ³ See page [168](#) ⁴ See page [169](#)

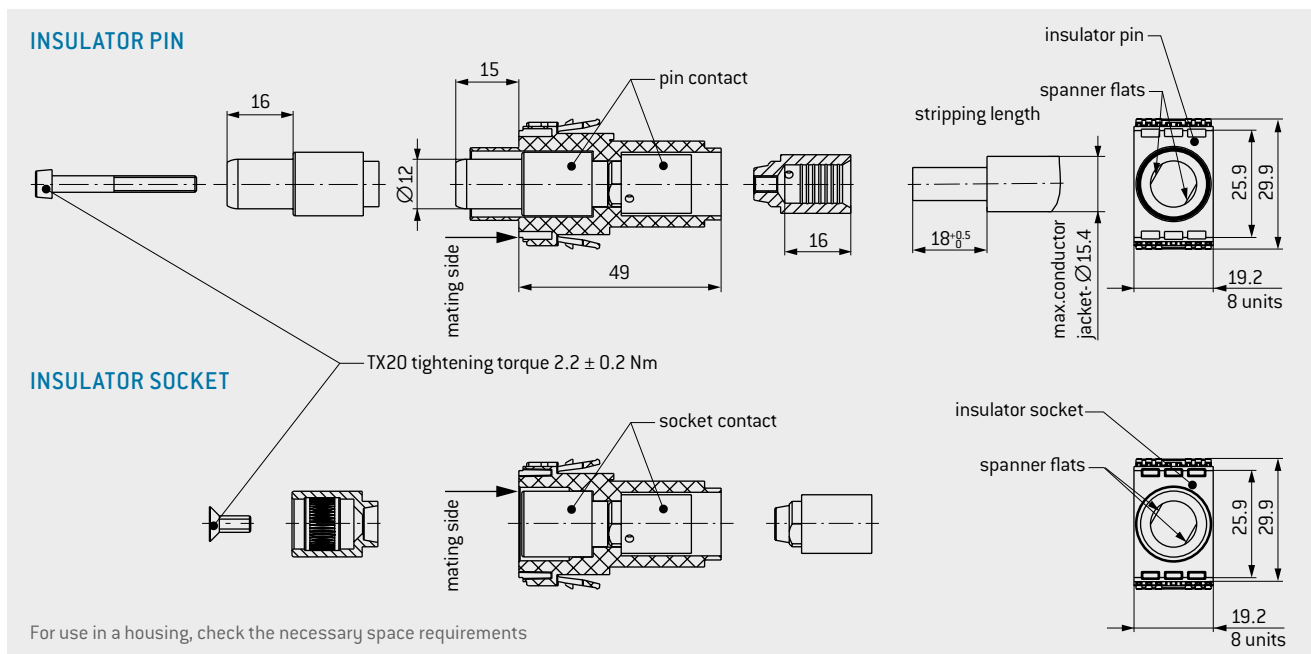

For use in a housing, check the necessary space requirements

ODU LAMTAC® (CONTACT WITH LAMELLA TECHNOLOGY)

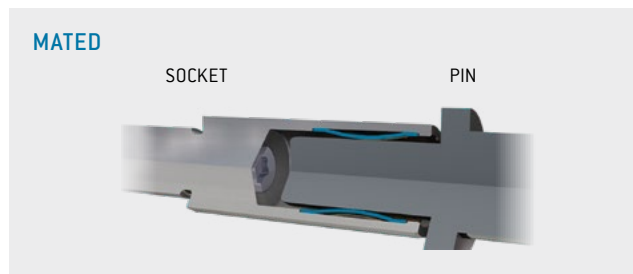
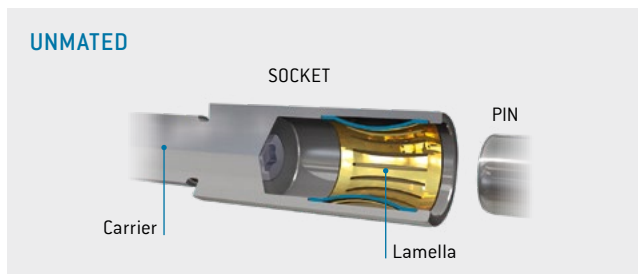

Module 1 contact	Part number
Insulator socket	630.115.101.923.000
Insulator pin	631.115.101.923.000

Description	Part number	Conductor crossection mm ²	Nominal current ¹	Max. continuous current ²	Contact resistance
			Single contact A	Single contact A	mΩ
Pin contact	181.944.100.200.001	25	115	167	0.1
Socket contact	178.948.100.201.001				
Pin contact	181.945.100.200.001	35	135	195	0.1
Socket contact	178.953.100.201.001				
Pin contact	181.943.100.200.001	50	155	225	0.1
Socket contact	178.943.100.201.001				

¹ Determined according to IEC 60512-5-2:2002 (DIN EN 60512-5-2:2003) at increased temperature 45 K² For a definition of max. continuous current, see page 172

MODULE 4 CONTACTS FOR 50 Ω

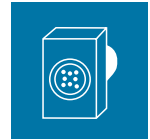

Mating cycles: min. 10,000
 Frequency range¹: 0–2.8 GHz

TECHNICAL NOTES

- For crimp information, see from page 154

TECHNICAL DATA

Voltage data according to IEC 60664-1:2007 (VDE 0110-1:2008)²

Frequency range¹ 0–2.8 GHz
 Insulation resistance > 100 GΩ

Clearance distance	1.5 mm	1.5 mm
Creepage distance	1.5 mm	1.5 mm
Pollution degree	2	3

Voltage data according to MIL³

Operating voltage 525 V
 Test voltage 1,575 V

Voltage data according to standard IEC 61010-1:2010 (VDE 0411-1:2010)⁴

Supply voltage from grid supply circuit (CAT.2) 150 V < U_{rms} ≤ 300 V

Operating voltage	300 V	50 V
Test voltage	1,383 V AC	1,383 V AC
Pollution degree	2	3

Mechanical data

Total mating force (average) 10.6 N/module
 Total sliding force (average) 7.6 N/module
 Operating temperature –40 °C to +125 °C
 Mating cycles min. 10,000

Materials

Insulator	thermoplastic acc. to UL 94
Contact/insulator	Cu alloy/PTFE
Contact finishing	gold-plated

HIGH-FREQUENCY CHARACTERISTICS FOR 50 Ω COAX CONTACTS¹

Insertion loss

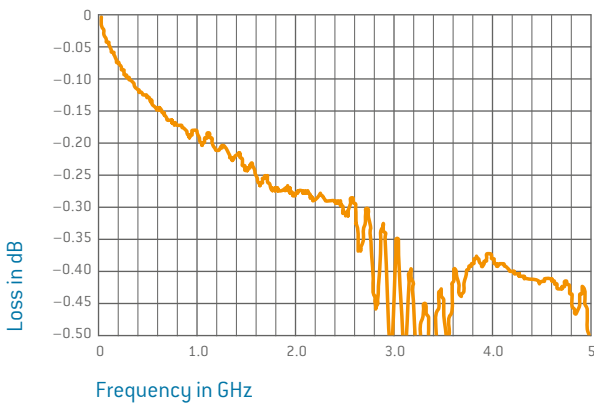

Voltage standing-wave ratio VSWR

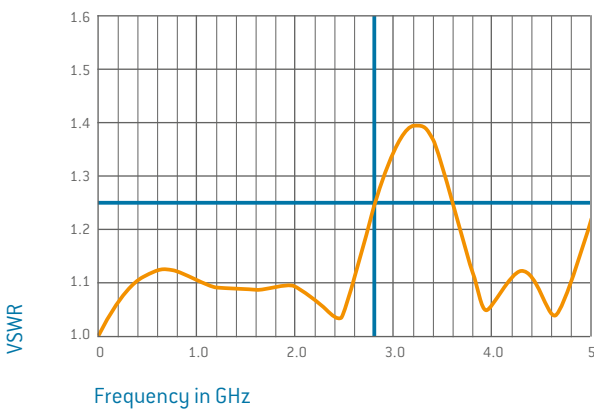

REMOVAL TOOL

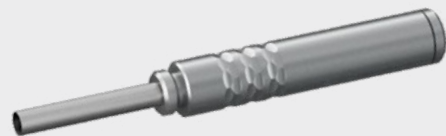

Removal of the assembled contact from the mating side
PART NUMBER: 087.7CC.310.001.000

For an overview of all tools, please see from page 153.

¹ Loss levels depend on used conductor type at a VSWR of 1.25. More are available on request. Each test was performed with a conductor length of 2 × 5 cm.
² IEC 60664-1:2007 (VDE 0110-1:2008) see page 165 ³ See page 169 ⁴ See page 168



INSULATOR FOR PIN AND SOCKET

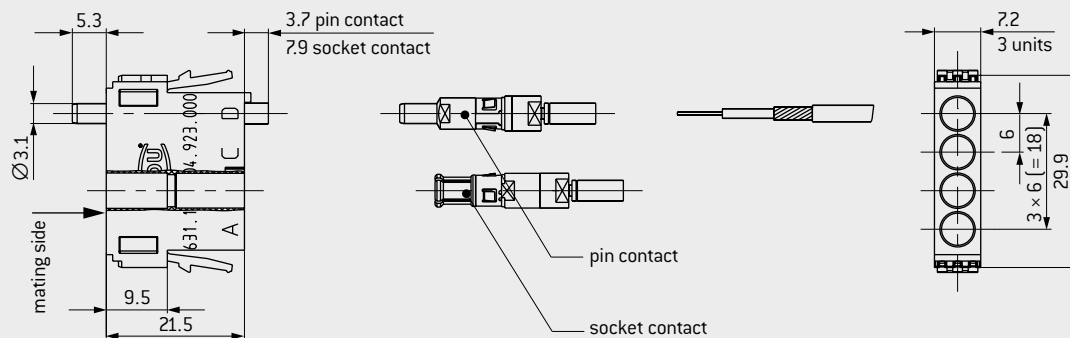

CABLE TERMINATION

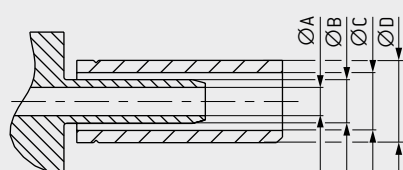

Inner conductor crimped, outer conductor crimped

RECOMMENDED CABLE CONSTRUCTION/STRIPPING LENGTH

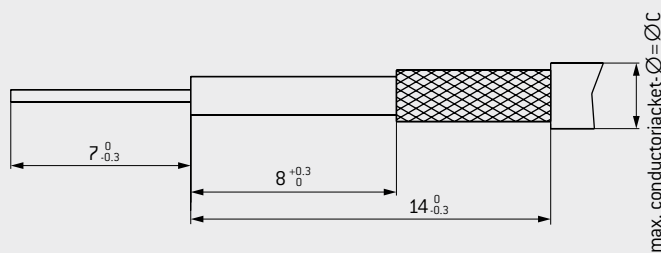

Module 4 contacts	Part number
Insulator	631.121.104.923.000

Description	Part number	Characteristic impedance Ω	Frequency range GHz	Cable ¹	A	B	C	D	Part number Crimp dies
Pin contact	122.133.003.270.000	50	0.5	RG 178, RG 196	1.1	1.7	2.25	3.2	082.000.039.101.000
Pin contact	122.133.001.270.000		2.8	RG 174, RG 188, RG 316	1.75	2.7	3.2	3.8	082.000.039.102.000
Socket contact	122.133.004.270.000	50	0.5	RG 178, RG 196	1.1	1.7	2.25	3.2	082.000.039.101.000
Socket contact	122.133.002.270.000		2.8	RG 174, RG 188, RG 316	1.75	2.7	3.2	3.8	082.000.039.102.000

¹ Special lines and alternative models on request

MODULE 2 CONTACTS FOR 50 Ω



Mating cycles: min. 10,000
Frequency range¹: 0–4 GHz

TECHNICAL NOTES

- For crimp information, see from page [154](#)

TECHNICAL DATA

Voltage data according to IEC 60664-1:2007 (VDE 0110-1:2008)²

Frequency range¹ 0–4 GHz
 Insulation resistance > 100 GΩ

Clearance distance	2.2 mm	2.2 mm
Creepage distance	3.1 mm	3.1 mm
Pollution degree	2	3

Voltage data according to MIL³

Operating voltage 800 V
 Test voltage 2,400 V

Voltage data according to standard DIN EN 61010-1:2010⁴

Supply voltage from grid supply circuit (CAT.2) 150 V < U_{rms} ≤ 300 V

Operating voltage	612 V	243 V
Test voltage	1,788 V AC	1,788 V AC
Pollution degree	2	3

Mechanical data

Total mating force (average) 8.1 N/module
 Total sliding force (average) 5.8 N/module
 Operating temperature –40 °C to +125 °C
 Mating cycles min. 10,000

Materials

Insulator thermoplastic acc. to UL 94
 Contact/insulator Cu alloy/PTFE
 Contact finishing gold-plated

HIGH-FREQUENCY CHARACTERISTICS FOR 50 Ω COAX CONTACTS¹

Insertion loss

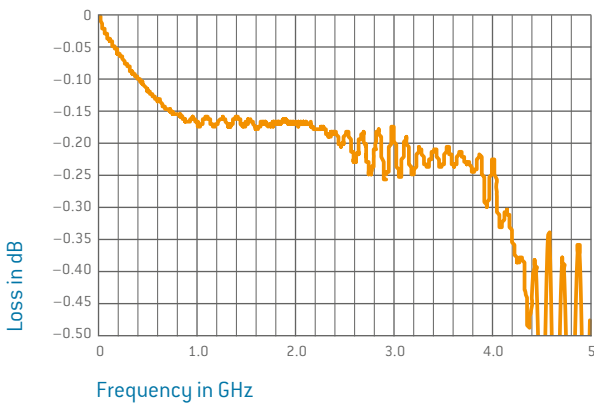

Voltage standing-wave ratio VSWR

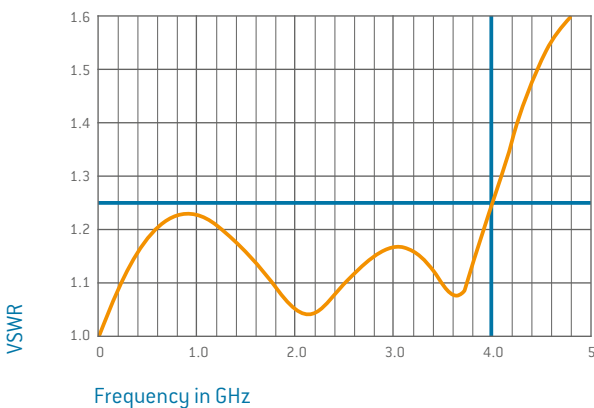

REMOVAL TOOL



Removal of the assembled contact from the mating side
PART NUMBER: 087.7CC.690.001.000

For an overview of all tools, please see from page [153](#).

¹ Loss levels depend on used conductor type at a VSWR of 1.25. More are available on request. Each test was performed with a conductor length of 2 × 5 cm.
² IEC 60664-1:2007 (VDE 0110-1:2008) see page [165](#) ³ See page [169](#) ⁴ See page [168](#)



INSULATOR FOR PIN AND SOCKET

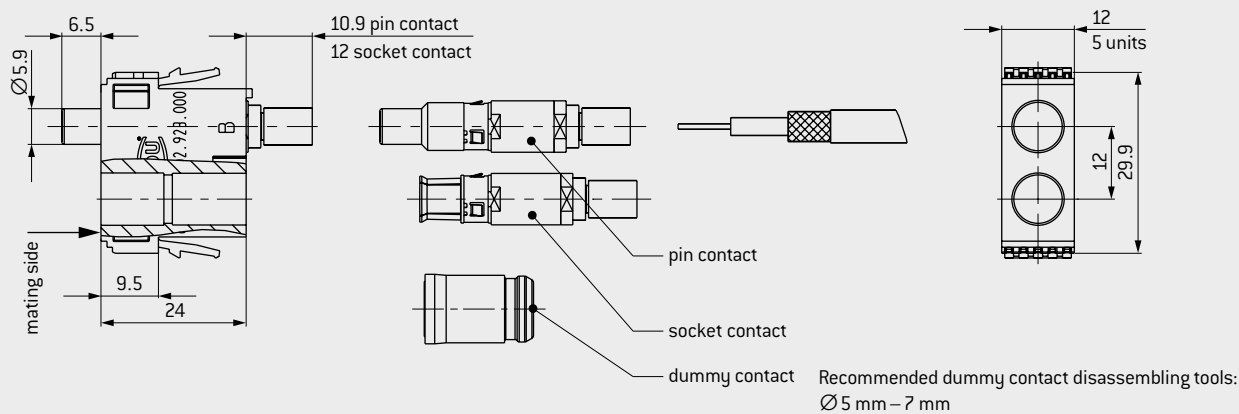

CABLE TERMINATION

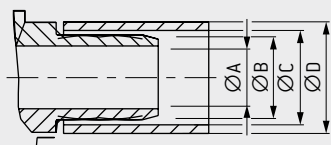

Inner conductor crimped, outer conductor crimped

RECOMMENDED CABLE CONSTRUCTION/STRIPPING LENGTH

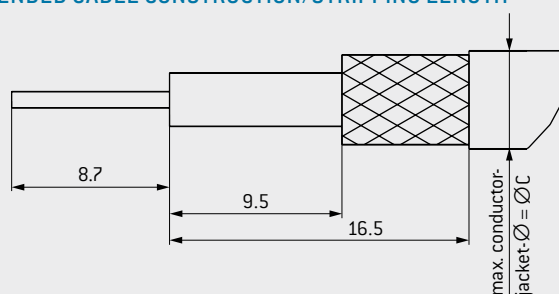

Module 2 contacts	Part number
Insulator	631.120.102.923.000
Dummy contact	021.341.202.946.000

Description	Part number	Characteristic impedance Ω	Frequency range GHz	Cable ¹	A	B	C	D	Part number Crimp dies
Pin contact	122.132.001.270.000	50	0.2	RG 178, RG 196	1.1	1.7	2.25	3.2	082.000.039.101.000
Pin contact	122.132.003.270.000		0.4	RG 174, RG 188, RG 316	1.75	2.7	3.2	3.8	082.000.039.102.000
Pin contact	122.132.007.270.000		3.5	RG 58	3.15	4.5	5.2	6.15	082.000.039.106.000
Pin contact	122.132.013.270.000		4	RG 223	3.15	4.5	5.9	6.75	082.000.039.108.000
Socket contact	122.132.002.270.000	50	0.2	RG 178, RG 196	1.1	1.7	2.25	3.2	082.000.039.101.000
Socket contact	122.132.004.270.000		0.4	RG 174, RG 188, RG 316	1.75	2.7	3.2	3.8	082.000.039.102.000
Socket contact	122.132.008.270.000		3.5	RG 58	3.15	4.5	5.2	6.15	082.000.039.106.000
Socket contact	122.132.014.270.000		4	RG 223	3.15	4.5	5.9	6.75	082.000.039.108.000

¹ Special lines and alternative models on request

MODULE 2 CONTACTS FOR 50 Ω WITH SMA TERMINATION



Mating cycles: min. 10,000
 Frequency range¹: 0–12 GHz²

TECHNICAL DATA

Voltage data according to IEC 60664-1:2007 (VDE 0110-1:2008)³

Frequency range ¹	0–12 GHz ²	
Insulation resistance	>100 GΩ	
Clearance distance	1.6 mm	1.6 mm
Creepage distance	1.6 mm	1.6 mm
Pollution degree	2	3

Voltage data according to MIL⁴

Operating voltage	565 V
Test voltage	1,700 V

Voltage data according to standard IEC 61010-1:2010 (VDE 0411-1:2010)⁵

Supply voltage from grid supply circuit (CAT.2)	150 V < U _{rms} ≤ 300 V	
Operating voltage	320 V	63 V
Test voltage	1,444 V AC	1,444 V AC
Pollution degree	2	3

Mechanical data

Total mating force (average)	8.1 N/module
Total sliding force (average)	5.8 N/module
Operating temperature	–40 °C to +125 °C
Mating cycles	min. 10,000

Materials

Insulator	thermoplastic acc. to UL 94
Contact/insulator	Cu alloy/PTFE
Contact finishing	gold-plated

HIGH-FREQUENCY CHARACTERISTICS FOR 50 Ω COAX CONTACTS¹

Insertion loss

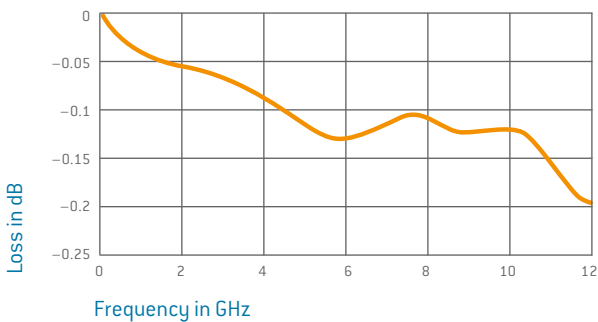

Voltage standing-wave ratio VSWR

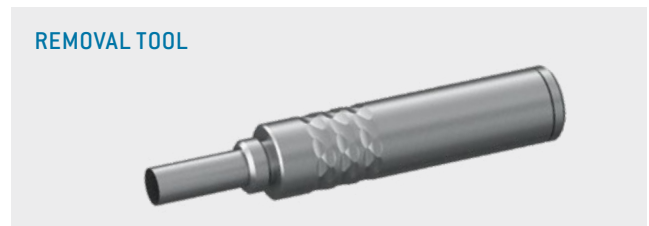
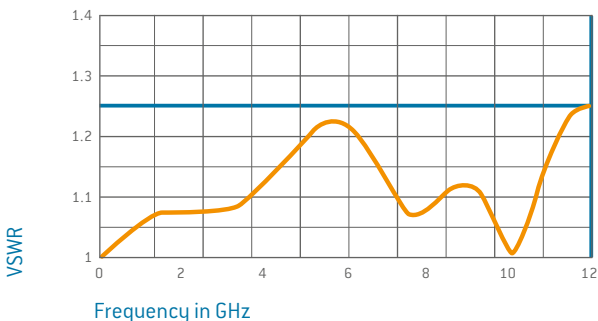

Removal of the assembled contact from the mating side
PART NUMBER: 087.7CC.690.001.000

For an overview of all tools, please see from page 153.

¹ Loss levels depend on used conductor type at a VSWR of 1.25. More are available on request. Each test was performed with a conductor length of 2 × 5 cm.

² Frequency range 0–16 GHz, if gap between pin and socket frame is < 0.2 mm and particular coax cables are used. Example: docking application

³ IEC 60664-1:2007 (VDE 0110-1:2008) see page 165 ⁴See page 169 ⁵See from page 168

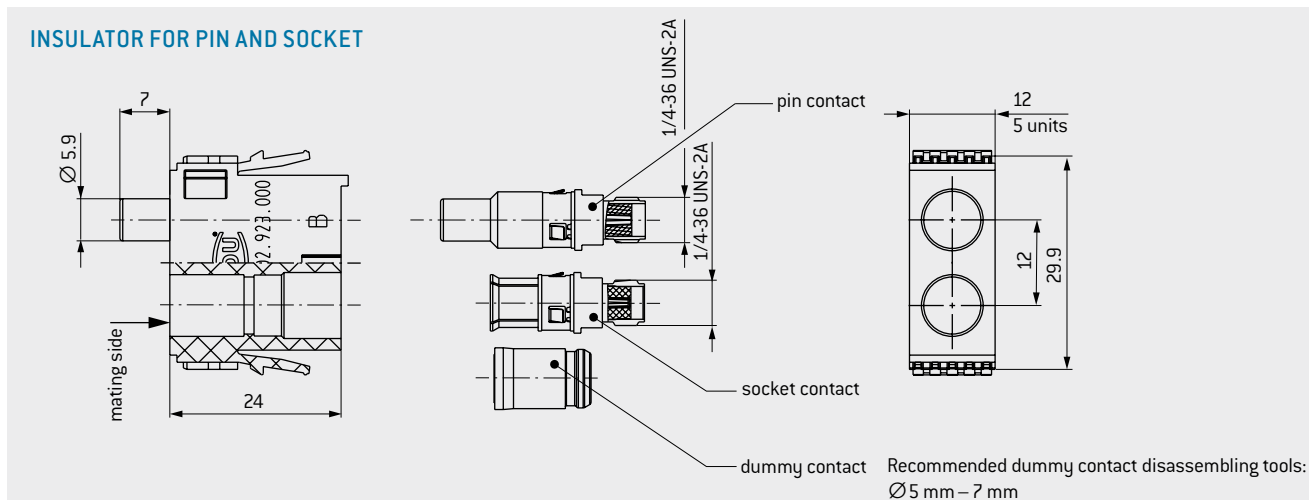

Module 2 contacts	Part number
Insulator	631.122.102.923.000
Dummy contact	021.341.202.946.000

Description	Part number	Characteristic impedance	Frequency range
		Ω	GHz
Pin contact	122.143.001.270.000	50	12 ¹
Socket contact	122.143.002.270.000		12 ¹

¹ Frequency range 0–16 GHz, if gap between pin and socket frame is < 0.2 mm and particular coax cables are used. Example: docking application

MODULE 2 CONTACTS FOR 75 Ω



Mating cycles: min. 10,000
Frequency range¹: 0–2.7 GHz

TECHNICAL NOTES

- For crimp information, see from page [154](#)

TECHNICAL DATA

Voltage data according to IEC 60664-1:2007 (VDE 0110-1:2008)²

Frequency range¹ 0–2.7 GHz
 Insulation resistance > 100 GΩ

Clearance distance	1.1 mm	1.1 mm
Creepage distance	1.1 mm	1.1 mm
Pollution degree	2	3

Voltage data according to MIL³

Operating voltage 930 V
 Test voltage 2,790 V

Voltage data according to standard IEC 61010-1:2010 (VDE 0411-1:2010)⁴

Supply voltage from grid supply circuit (CAT.2) 150 V < U_{rms} ≤ 300 V

Operating voltage	220 V	16 V
Test voltage	1,138 V AC	1,138 V AC
Pollution degree	2	3

Mechanical data

Total mating force (average) 8.1 N/module
 Total sliding force (average) 5.8 N/module
 Operating temperature –40 °C to +125 °C
 Mating cycles min. 10,000

Materials

Insulator thermoplastic acc. to UL 94
 Contact/insulator Cu alloy/PTFE
 Contact finishing gold-plated

HIGH-FREQUENCY CHARACTERISTICS FOR 75 Ω COAX CONTACTS¹

Insertion loss

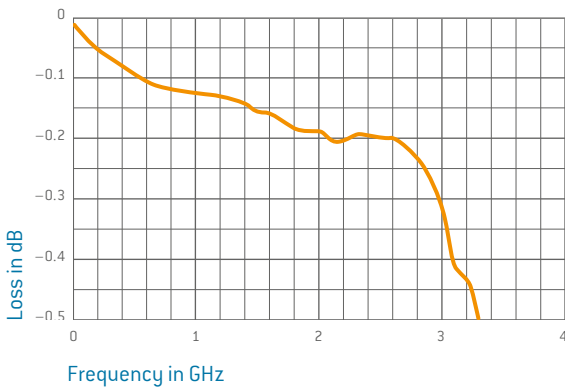

Voltage standing-wave ratio VSWR

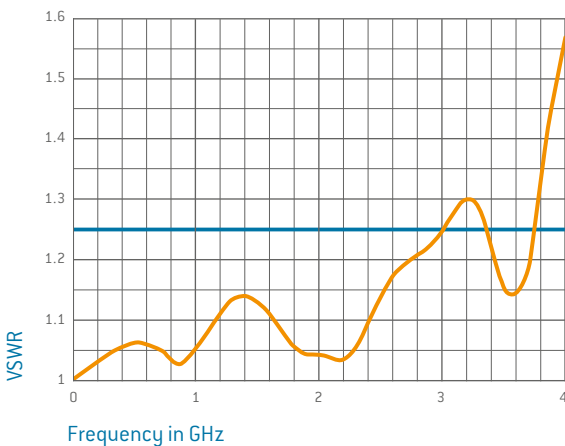

REMOVAL TOOL

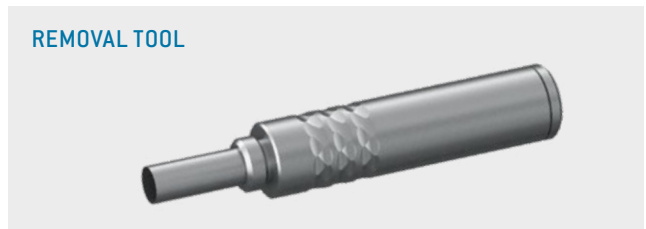

Removal of the assembled contact from the mating side

PART NUMBER: 087.7CC.690.001.000

For an overview of all tools, please see from page [153](#).

¹ Loss levels depend on used conductor type at a VSWR of 1.25. More are available on request. Each test was performed with a conductor length of 2 × 5 cm.

² IEC 60664-1:2007 (VDE 0110-1:2008) see page [165](#) ³ See from page [169](#) ⁴ See page [168](#)



INSULATOR FOR PIN AND SOCKET

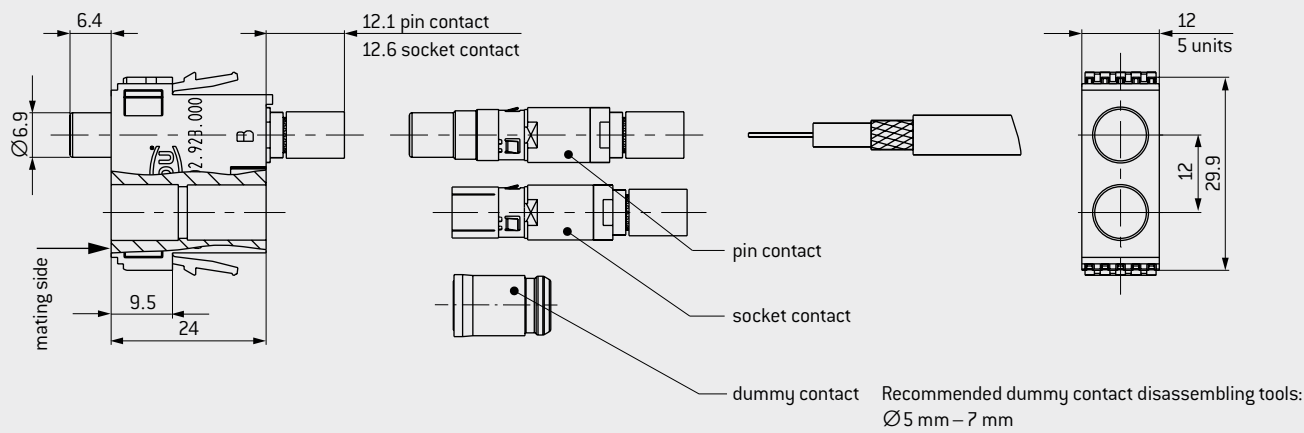

CABLE TERMINATION

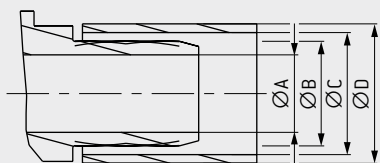

Inner conductor crimped, outer conductor crimped

RECOMMENDED CABLE CONSTRUCTION/STRIPPING LENGTH

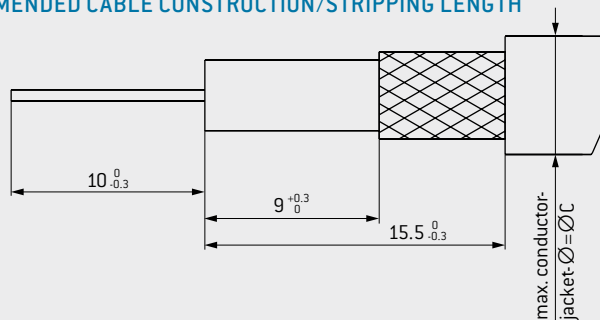

Module 2 contacts	Part number
Insulator	631.120.102.923.000
Dummy contact	021.341.202.946.000

Description	Part number	Characteristic impedance Ω	Frequency range GHz	Cable ¹	A	B	C	D	Part number Crimp dies
Pin contact	122.131.003.270.000	75	1.2	RG 179, RG 187	1.75	2.7	3.2	3.8	082.000.039.102.001
Pin contact	122.131.009.270.000		2.7	RG 59	4	5.4	6.3	7.2	082.000.039.109.000
Socket contact	122.131.004.270.000	75	1.2	RG 179, RG 187	1.75	2.7	3.2	3.8	082.000.039.102.001
Socket contact	122.131.010.270.000		2.7	RG 59	4	5.4	6.3	7.2	082.000.039.109.000

¹ Special lines and alternative models on request

MODULE 2 CONTACTS FOR PNEUMATIC VALVES



Inner- \varnothing of tube max. 4 mm, Push-in- \varnothing max. 6 mm



Operating pressure¹: 12 bar
 Mating cycles²: minimum 10,000
 Tube termination: M5

TECHNICAL NOTES

- The function dictates that contacts are pre-stressed in the mated state. The frame must maintain this pre-stress with a holding device.
- Vacuum modules and further termination types on request
- No O₂ model³

TECHNICAL DATA

Mechanical data

Permissible max. operating pressure	12 bar
Operating force	10.4 N/module
Operating temperature	-40 °C to +125 °C
Mating cycles	min. 10,000
Tube termination	M5 inside thread for commercially available Push-in terminations

Materials

Insulator	thermoplastic acc. to UL 94
Valve body	Cu alloy, blank
Sealing	NBR; sealing material



REMOVAL TOOL

Removal of the assembled contact from the mating side
PART NUMBER: 087.7CC.680.001.000

For an overview of all tools, please see from page 153.

FLOW RATE DIAGRAM

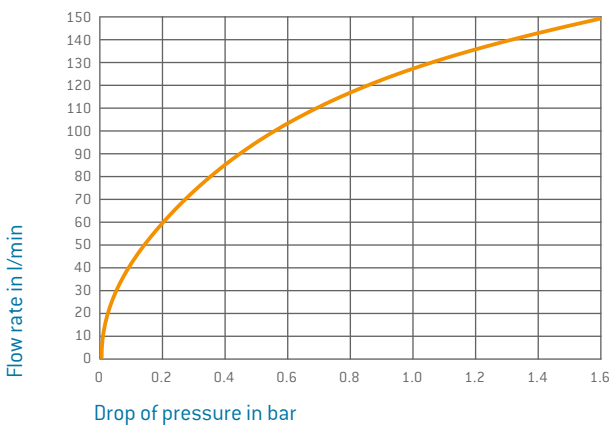

The flow rate diagram refers to the locking version with a maximum gap between socket and pin piece of ≤ 0.5 mm. If the clearance is modified, the drop of pressure increases.

¹ Burst pressure min. 40 bar ² The stated mating cycles are possible if regular maintenance intervals are observed ³ Not suitable for mixtures with over 25% oxygen content or explosive gases.



INSULATOR PIN AND SOCKET

TERMINATION ACCESSORIES, SEE PAGE 136

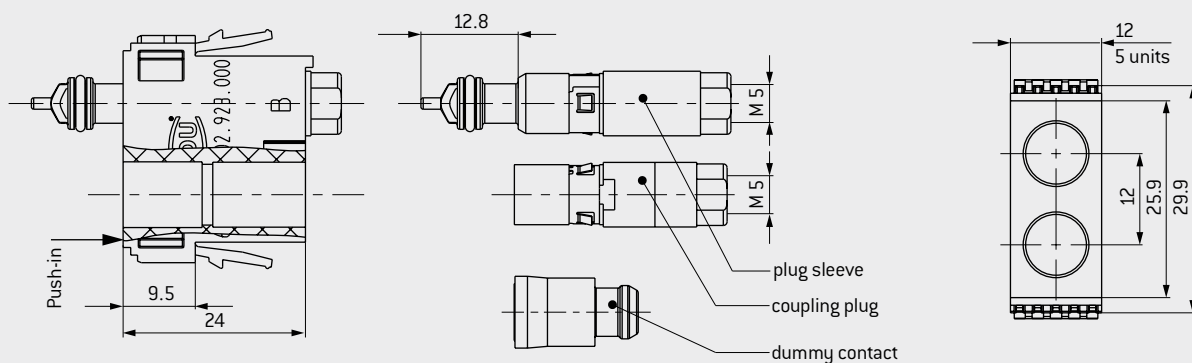

Recommended dummy contact disassembling tools:
 Ø3 mm – 4.5 mm

Module 2 contacts	Part number
Insulator	631.120.102.923.000
Dummy contact	021.341.202.946.000

Description	Part number	Termination
Plug sleeve (non shut-off)	196.035.001.300.000	M5
Coupling (non shut-off)	196.035.003.300.000	
Coupling (shut-off)	196.035.002.300.000	

MODULE 2 CONTACTS FOR PNEUMATIC VALVES



Inner- \varnothing of tube max. 4 mm, Push-in- \varnothing max. 6 mm.

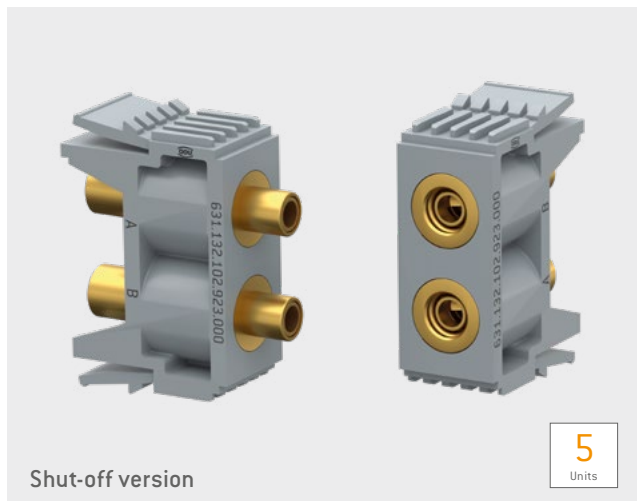
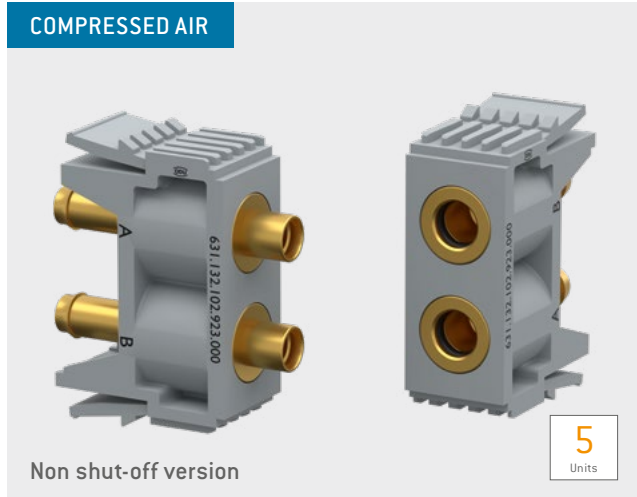

Operating pressure: 10 bar
 Mating cycles¹: min. 10,000
 Tube termination: M5 or max. 4 mm

TECHNICAL NOTES

- The function dictates that contacts are pre-stressed in the mated state. The frame must maintain this pre-stress with a holding device.
- Vacuum modules and further termination types on request
- No O₂ model²

TECHNICAL DATA

Mechanical data

Permissible max. operating pressure 10 bar	
Operating force	
Non shut-off	27 N/module
One-sided shut-off	28 N/module
Two-sided shut-off	29 N/module
Total sliding force (average)	
Non shut-off	12.6 N/module
One-sided shut-off	12.6 N/module
Two-sided shut-off	9.2 N/module
Operating temperature	
-40 °C to +125 °C	
Mating cycles ¹	
min. 10,000	
Tube termination	
M5 inside thread for commercially available Push-in terminations	

Materials

Insulator	thermoplastic glass-fiber reinforced acc. to UL 94
Valve body	Cu alloy, blank
Sealing	NBR; sealing material/FKM

FLOW RATE DIAGRAM

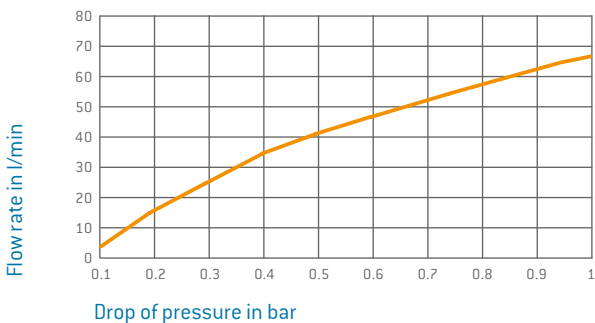

The flow rate diagram refers to the locking version with a maximum gap between socket and pin piece of ≤ 0.5 mm. If the clearance is modified, the drop of pressure increases.

¹ The stated mating cycles are possible if regular maintenance intervals are observed ² Not suitable for mixtures with over 25% oxygen content or explosive gases



INSULATOR PIN AND SOCKET

TERMINATION ACCESSORIES, SEE PAGE 136

Module 2 contacts	Part number
Insulator	631.132.102.923.000
Dummy contact	021.341.205.946.000

Description	Part number	Dim. A mm	Dim. X mm	Termination types see page 136	
				I	II
Plug sleeve (non shut-off)	196.023.001.300.000	3	8.5	x	
Plug sleeve (non shut-off)	196.024.001.300.000	4	10.5	x	
Coupling (non shut-off)	196.023.003.300.000	3	8.5	x	
Coupling (non shut-off)	196.024.003.300.000	4	10.5	x	
Plug sleeve (shut-off) ^{1,2}	196.025.014.300.000	M5	–		x
Coupling (shut-off)	196.023.002.300.000	3	8.5	x	
Coupling (shut-off)	196.024.002.300.000	4	10.5	x	
Coupling (shut-off) ²	196.025.012.300.000	M5	–		x

¹Only pluggable on coupling 196.025.012.300.000 ²Sealing material: FKM

MODULE 2 CONTACTS FOR FLUID COUPLING



Suitable for conducting air, water, and other fluids

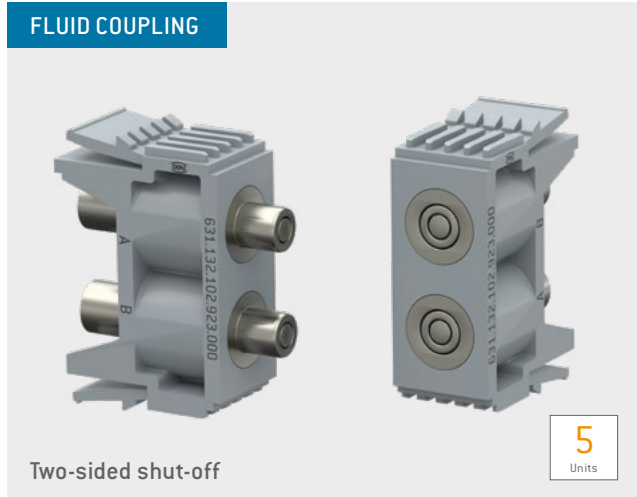

Operating pressure: 10 bar low-leakage model
 Mating cycles¹: min. 10,000
 Tube termination: M5

TECHNICAL NOTES

- The function dictates that contacts are pre-stressed in the mated state. The frame must maintain this pre-stress with a holding device.
- The use of flammable or explosive liquids or gases is not permitted.
- No O₂ model²

TECHNICAL DATA

Mechanical data

Permissible max. operating pressure	10 bar
Tube termination	M5 inside thread for commercially available Push-in terminations
Operating force	48 N/module
Operating temperature	-40 °C to +125 °C
Mating cycles ¹	min. 10,000

Materials

Insulator	thermoplastic glass-fiber reinforced acc. to UL 94
Fluid coupling	Cu alloy/nickel-plated
Sealing	sealing material/FKM

FLOW RATE DIAGRAM AIR

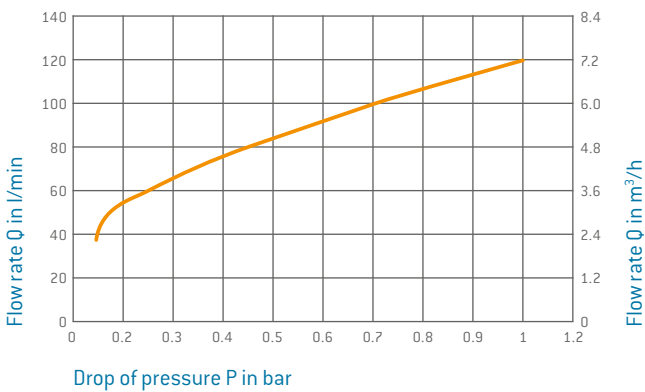

FLOW RATE DIAGRAM WATER

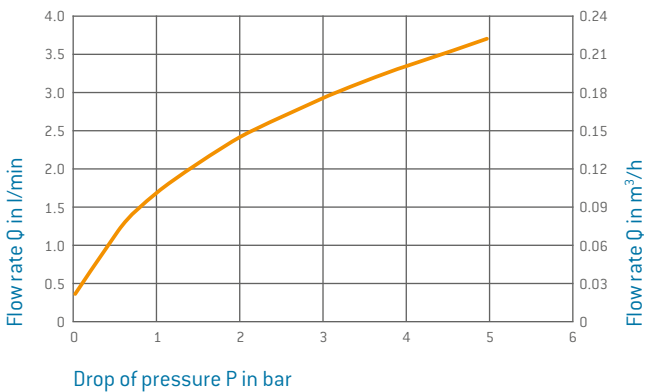

The flow rate diagram refers to the locking version with a maximum gap between socket and pin piece of ≤ 0.5 mm. If the clearance is modified, the drop of pressure increases.

¹ The stated mating cycles are possible if regular maintenance intervals are observed ² Not suitable for mixtures with over 25% oxygen content or explosive gases



INSULATOR PIN AND SOCKET

TERMINATION ACCESSORIES, SEE PAGE 136

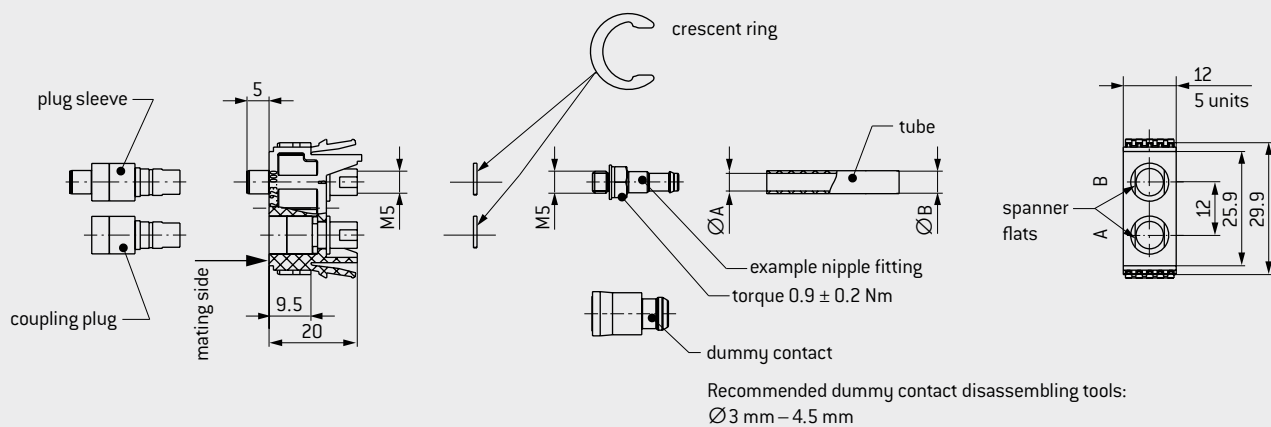

Module 2 contacts	Part number
Insulator	631.132.102.923.000
Dummy contact	021.341.205.946.000

Description	Part number	Termination
Plug sleeve (shut-off)	196.025.015.338.000	M5
Coupling (shut-off)	196.025.016.338.000	M5

M5 TERMINATION ACCESSORIES

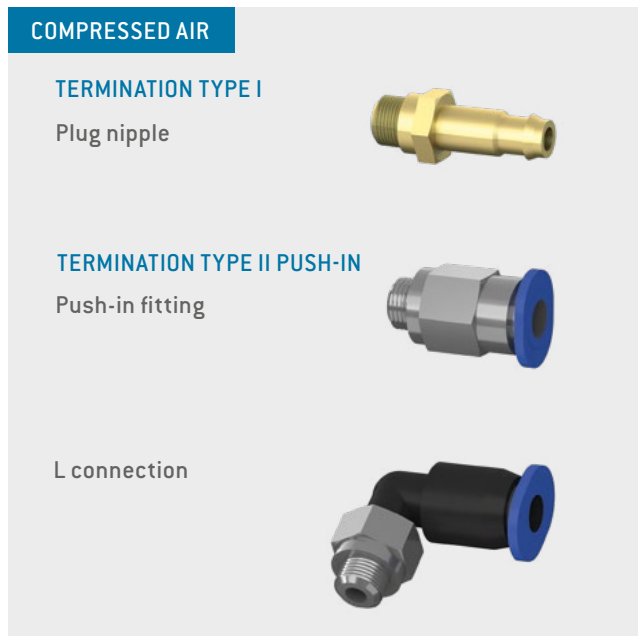

TECHNICAL NOTES

- Tightening torque 0.9 ± 0.2 Nm

TECHNICAL DATA

Mechanical data

Permissible operating pressure (static) 0.95–14 bar
 Operating temperature for Push-in –10 °C to +80 °C
 Thread termination M5

Description	Part number	Dim. A	Dim. B	Dim. C	Dim. D	Dim. E	Dim. F
		Inner-Ø of tube mm	Outer-Ø of tube mm	mm	mm	mm	mm
Plug nipple	945.000.001.000.123	2		10.2			
Plug nipple	945.000.001.000.136	3		14.2			
Plug nipple	945.000.001.000.137	4		15.8			
Push-in fitting	945.000.001.000.138		3		13		
Push-in fitting	945.000.001.000.139		4		13.2		
Push-in fitting	945.000.001.000.140		6		14.2		
L connection Push-in	945.000.001.000.141		3			14	11
L connection Push-in	945.000.001.000.142		4			14.9	15.6
L connection Push-in	945.000.001.000.143		6			17.2	16.2



TERMINATION DIMENSIONS ACCESSORIES PNEUMATIC VALVES

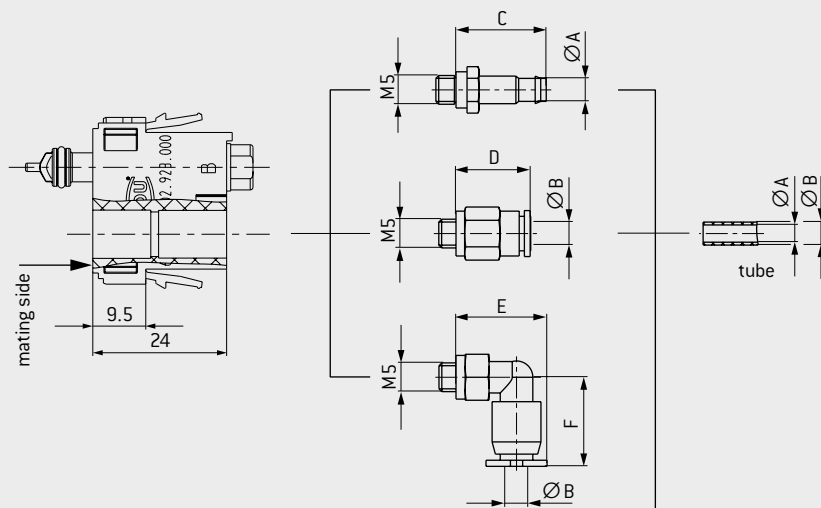

MODULE FOR MULTI-POSITION SHIELDED FEEDTHROUGH/HIGH-SPEED CONNECTOR

Size 1 (e.g., for use in bus systems), 2 feedthroughs

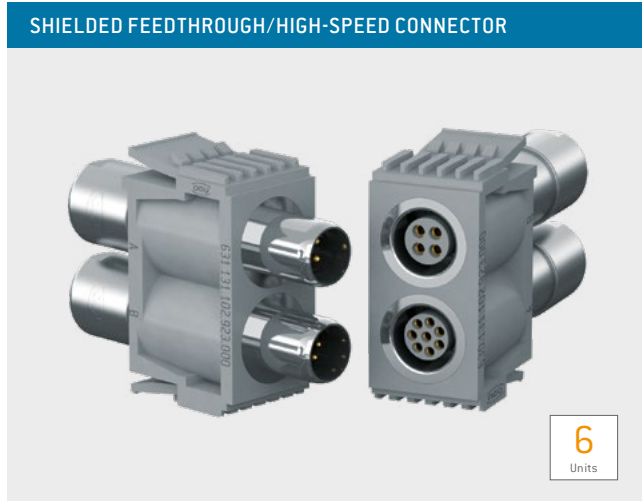

Mating cycles: min. 10,000
 CAT 5¹, USB[®] 2.0¹
 2 to 14 contacts

TECHNICAL NOTES

- The inserts listed here for shielded feedthroughs/ high-speed connectors are ideal for all common bus systems with transfer rates up to 10.0 MHz, e.g., Profibus^{®1}, RS485, FlexRay^{®1}, CAN-Bus¹, and RS232.
- Selected inserts are suitable and qualified for data rates up to 1 Gbit/s, e.g., Gigabit-Ethernet¹, Fast-Ethernet¹, IEEE 1394, USB[®] 2.0¹, FireWire[®] S400¹ (on request).

HOW TO CONFIGURE YOUR HIGH-SPEED CONNECTOR

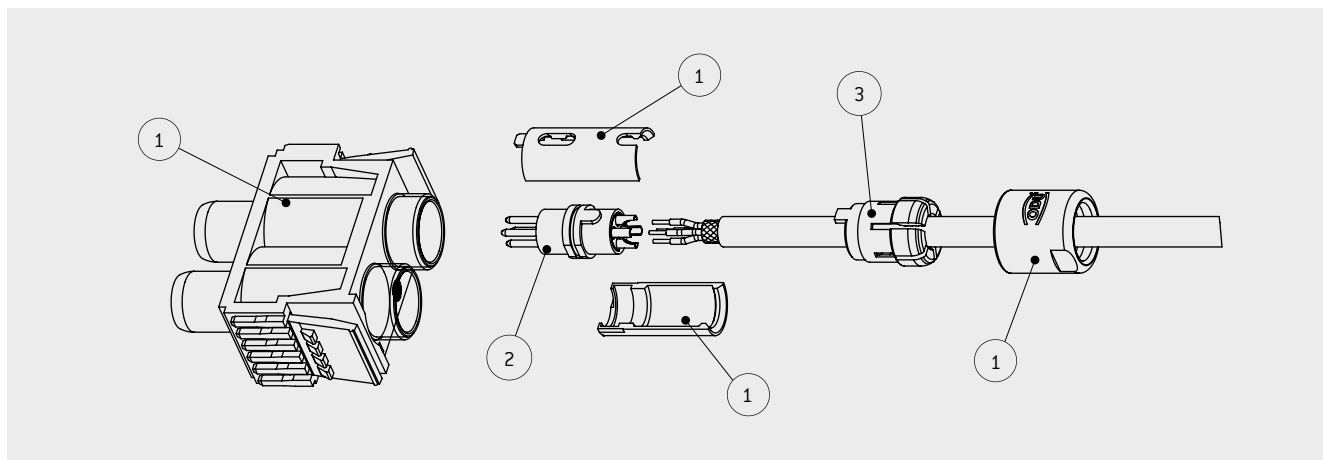

ASSEMBLY SET

Order	Base parts	Part number
1	Insulator socket incl. socket housing	630.131.102.923.000
1	Insulator pin incl. connector housing	631.131.102.923.000
2	Insert cpl. solder contacts ²	See next page
3	Assembly set	See table on the right

Cable-Ø mm	Part number
1.5 to 2.1	751.020.188.304.022
2 to 3.2	751.020.188.304.032
3 to 4.2	751.020.188.304.042
4 to 5.2	751.020.188.304.052
5 to 6.2	751.020.188.304.062
6 to 7.2	751.020.188.304.072
7 to 7.7	751.020.188.304.077

¹Concerning data transmission protocols, please note page 2. ²Insert for crimp contacts on request



INSULATOR PIN

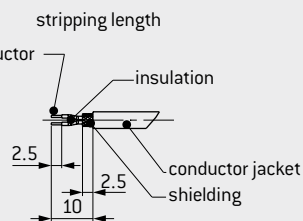
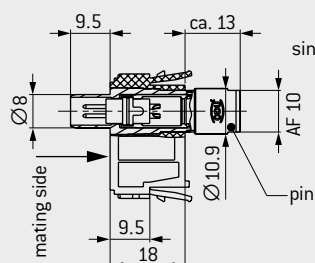

INSULATOR SOCKET

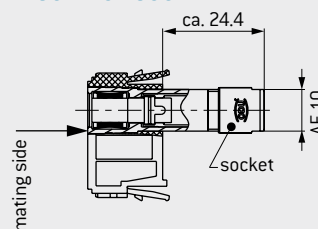
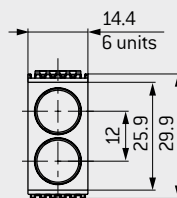

For use in a housing, check the necessary space requirements

CONTACT ARRANGEMENTS

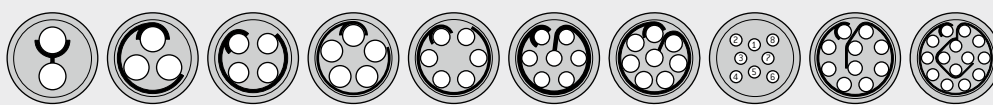

2 contacts 3 contacts 4 contacts 5 contacts 6 contacts 7 contacts 8 contacts 8 contacts 10 contacts 14 contacts
 CAT 5¹ USB[®] 2.0¹ CAT 5¹ USB[®] 3.1 Gen1¹

Number of contacts	Contact-Ø mm	Termination cross-section AWG	Rated voltage ² V	Rated surge voltage ² kV	Pollution degree ²	Nominal voltage ³ V AC	Model	Catego-ry ⁴	Insert cpl. ⁵ part number	Total mating force N	Total sliding force N
--------------------	-----------------	----------------------------------	---------------------------------	--	-------------------------------	--------------------------------------	-------	------------------------	---	-------------------------	--------------------------

INSERT WITH ODU TURNTAC[®] (MATING CYCLES MIN. 10,000)

2	1.3	20	32	2	3	550	Pin		701.844.724.002.200	8.5	7.5
			80				Socket		701.744.724.002.200		
3	1.3	20	16	2	3	500	Pin		701.844.724.003.200	8.5	7.5
			40				Socket		701.744.724.003.200		
4	0.9	22	10	2	3	500	Pin	CAT 5 ¹	701.849.724.004.200	10.5	9
			32				Socket		701.749.724.004.200		
4	0.9	22	10	2	3	500	Pin	USB [®] 2.0 ¹	701.849.724.004.D00	10.5	9
			32				Socket		701.749.724.004.D00		
5	0.9	22	32	1.5	2	450	Pin		701.849.724.005.200	10.5	9
							Socket		701.749.724.005.200		
6	0.7	22	32	1.5	2	400	Pin		701.848.724.406.200	13	10
							Socket		701.748.724.406.200		
7	0.7	22	32	1.5	2	400	Pin		701.848.724.407.200	13	10
							Socket		701.748.724.407.200		
8	0.7	22	32	1.5	2	333	Pin		701.848.724.408.200	13	10
							Socket		701.748.724.408.200		
8	0.5	26	32	1.5	2	333	Pin	CAT 5 ¹	701.841.724.408.D00	13	10
							Socket		701.741.724.408.D00		
10	0.5	28	25	1.5	2	333	Pin		701.841.724.010.400	15	12
							Socket		701.741.724.010.200		
10	6 × 0.3 4 × 0.5	28	10	1.2	2	100	Pin	USB [®] 3.1 Gen1 ¹	701.831.724.410.D00	16	12
		24					Socket		701.731.724.410.D00		
14	0.5	28	25	1.5	2	300	Pin		701.841.724.014.400	15	12
							Socket		701.741.724.014.200		

If required, selected inserts with 60,000 mating cycles (ODU SPRINGTAC[®]) available on request

¹ Concerning data transmission protocols, please note page 2. ² According to IEC 60664-1:2007 [VDE 0110-1:2008], see page 165

³ According to EIA-364-20F:2009 ⁴ Classification according to ISO/IEC 11801:2017-1 ⁵ Insert for crimp version on request

MODULE FOR MULTI-POSITION SHIELDED FEEDTHROUGH/HIGH-SPEED CONNECTOR

Size 1 (e.g., for use in bus systems), 1 feedthrough

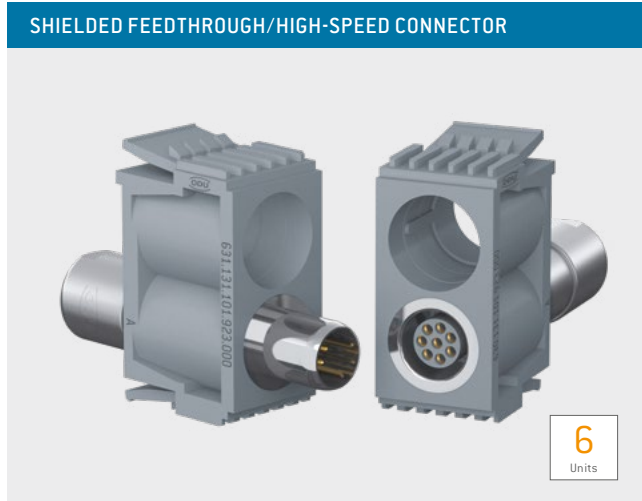

Mating cycles: min. 10,000
 CAT 5¹, USB[®] 2.0¹
 2 to 14 contacts

TECHNICAL NOTES

- The inserts listed here for shielded feedthroughs/high-speed connectors are ideal for all common bus systems with transfer rates up to 10.0 MHz, e.g., Profibus^{®1}, RS485, FlexRay^{®1}, CAN-Bus¹, and RS232.
- Selected inserts are suitable and qualified for data rates up to 1 Gbit/s, e.g., Gigabit-Ethernet¹, Fast-Ethernet¹, IEEE 1394, USB[®] 2.0¹, FireWire[®] S400¹ (on request).

HOW TO CONFIGURE YOUR HIGH-SPEED CONNECTOR

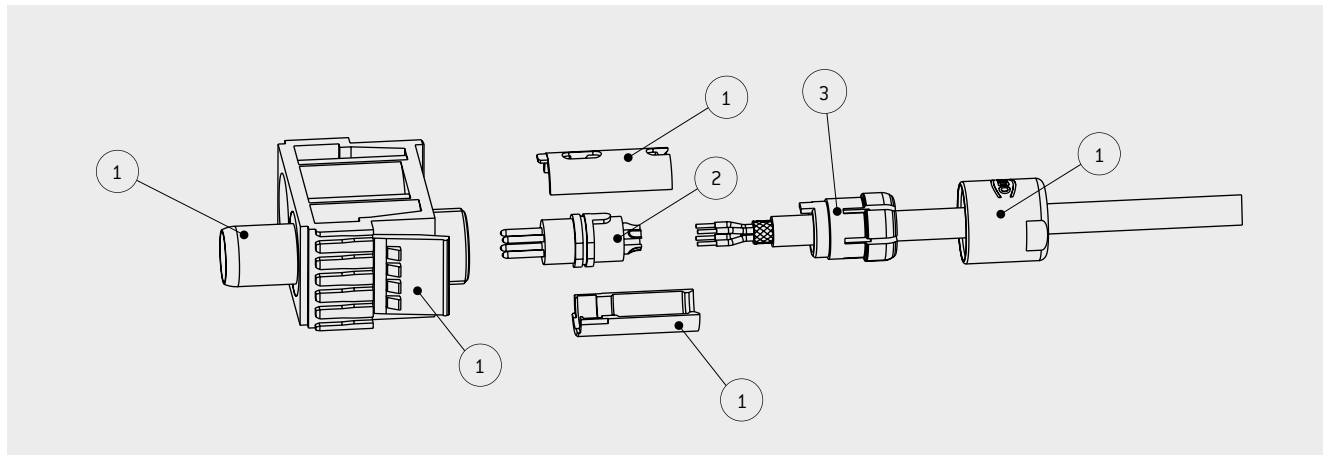

ASSEMBLY SET

Order	Base parts	Part number
1	Insulator socket incl. socket housing	630.131.101.923.000
1	Insulator pin incl. connector housing	631.131.101.923.000
2	Insert cpl. solder contacts ²	See next page
3	Assembly set	See table on the right
	Dummy contact	021.341.204.946.000

Cable-Ø mm	Part number
1.5 to 2.1	751.020.188.304.022
2 to 3.2	751.020.188.304.032
3 to 4.2	751.020.188.304.042
4 to 5.2	751.020.188.304.052
5 to 6.2	751.020.188.304.062
6 to 7.2	751.020.188.304.072
7 to 7.7	751.020.188.304.077

¹Concerning data transmission protocols, please note page 2. ²Insert for crimp contacts on request



INSULATOR PIN

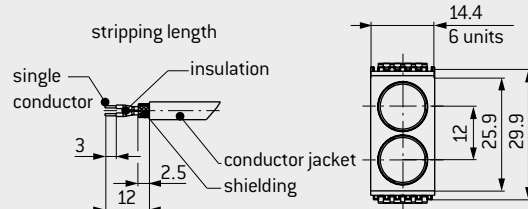
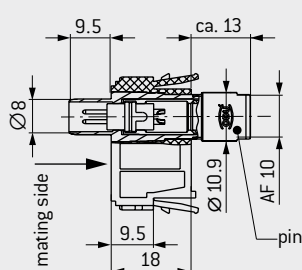

INSULATOR SOCKET

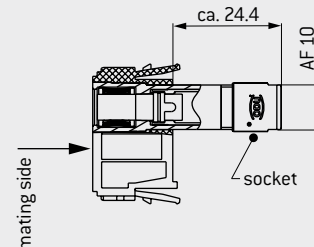

For use in a housing, check the necessary space requirements

CONTACT ARRANGEMENTS

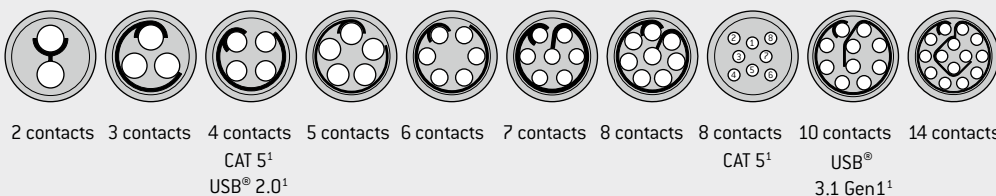

Number of contacts	Contact-Ø mm	Termination cross-section AWG	Rated voltage ² V	Rated surge voltage ² kV	Pollution degree ²	Nominal voltage ³ V AC	Model	Category ⁴	Insert cpl. ⁵ part number	Total mating force N	Total sliding force N
--------------------	-----------------	----------------------------------	---------------------------------	--	-------------------------------	--------------------------------------	-------	-----------------------	---	-------------------------	--------------------------

INSERT WITH ODU TURNTAC® (MATING CYCLES MIN. 10,000)

2	1.3	20	32	2	3	550	Pin		701.844.724.002.200	8.5	7.5
			80		2		Socket		701.744.724.002.200		
3	1.3	20	16	2	3	500	Pin		701.844.724.003.200	8.5	7.5
			40		2		Socket		701.744.724.003.200		
4	0.9	22	10	2	3	500	Pin	CAT 5 ¹	701.849.724.004.200	10.5	9
			32		2		Socket		701.749.724.004.200		
4	0.9	22	10	2	3	500	Pin	USB® 2.0 ¹	701.849.724.004.000	10.5	9
			32		2		Socket		701.749.724.004.000		
5	0.9	22	32	1.5	2	450	Pin		701.849.724.005.200	10.5	9
					2		Socket		701.749.724.005.200		
6	0.7	22	32	1.5	2	400	Pin		701.848.724.406.200	13	10
					2		Socket		701.748.724.406.200		
7	0.7	22	32	1.5	2	400	Pin		701.848.724.407.200	13	10
					2		Socket		701.748.724.407.200		
8	0.7	22	32	1.5	2	333	Pin		701.848.724.408.200	13	10
					2		Socket		701.748.724.408.200		
8	0.5	26	32	1.5	2	333	Pin	CAT 5 ¹	701.841.724.408.000	13	10
					2		Socket		701.741.724.408.000		
10	0.5	28	25	1.5	2	333	Pin		701.841.724.010.400	15	12
					2		Socket		701.741.724.010.200		
10	6 × 0.3 4 × 0.5	28	10	1.2	2	100	Pin	USB® 3.1 Gen1 ¹	701.831.724.410.000	16	12
		24					2		Socket		
14	0.5	28	25	1.5	2	300	Pin		701.841.724.014.400	15	12
					2		Socket		701.741.724.014.200		

If required, selected inserts with 60,000 mating cycles (ODU SPRINGTAC®) available on request

¹ Concerning data transmission protocols, please note page 2. ² According to IEC 60664-1:2007 (VDE 0110-1:2008), see page 165

³ According to EIA-364-20F:2009 ⁴ Classification according to ISO/IEC 11801:2017-1 ⁵ Insert for crimp version on request

MODULE FOR INDUSTRIAL ETHERNET¹ RJ45 / 10 GBIT/S

STEADYTEC® Technology



HIGH-SPEED CONNECTOR



7
Units

COUPLING FOR RJ45 CONNECTION ON THE SOCKET SIDE

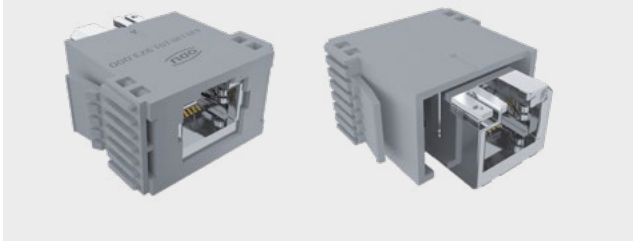

NEXT

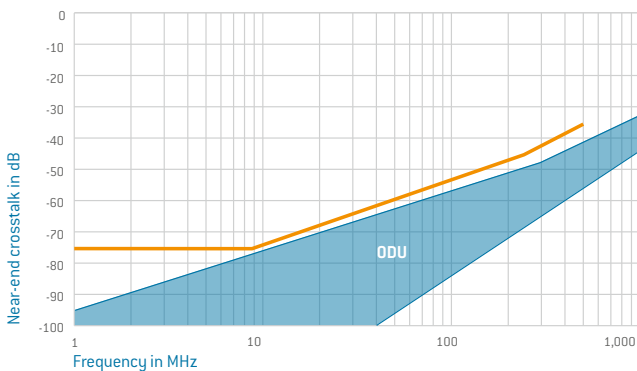

Mating cycles: min. 5,000
TIAA/TIAB/Profinet¹/CAT 5¹/CAT 6_A¹
8 contacts

TECHNICAL NOTES

- Data transmission
- This module is suitable for transmitting data according to CAT 6_A¹ TIA/EIA-568-B.2-10 ISO/IEC 11801:2007. Suitable for the transmission of 10 Gbit/s according to IEEE 802.3.
- 8-way RJ45 field connector and RJ45 connector insert CAT 6_A¹ (assembly w/o special tools) for stranded and solid wire cables
- Improved vibration and shock resistance by, for example, using 4 springs at the shrouds in the RJ45 socket of the RJ45 module CAT 6_A¹ and RJ45 coupling CAT 6_A¹
- Multi-port capable

TECHNICAL DATA

Contact resistance	< 20 mΩ
Insulation resistance	> 500 MΩ
Mating cycles	min. 5,000

Dielectric strength

Contact – contact	> 1,000 V, DC
Contact – shield	> 1,500 V, DC
Current-carrying capacity	1 A

Transfer impedance

at 1 MHz	< 100 mΩ
at 10 MHz	< 200 mΩ
at 80 MHz	< 1,600 mΩ

Materials

Surface	Sn
---------	----

Temperature range

–40 °C to +70 °C

¹ Concerning data transmission protocols, please note page 2.



INSULATOR PIN

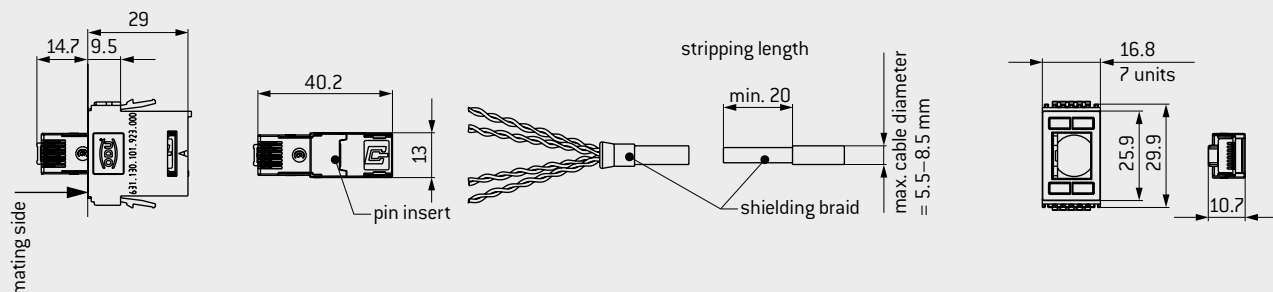

INSULATOR SOCKET

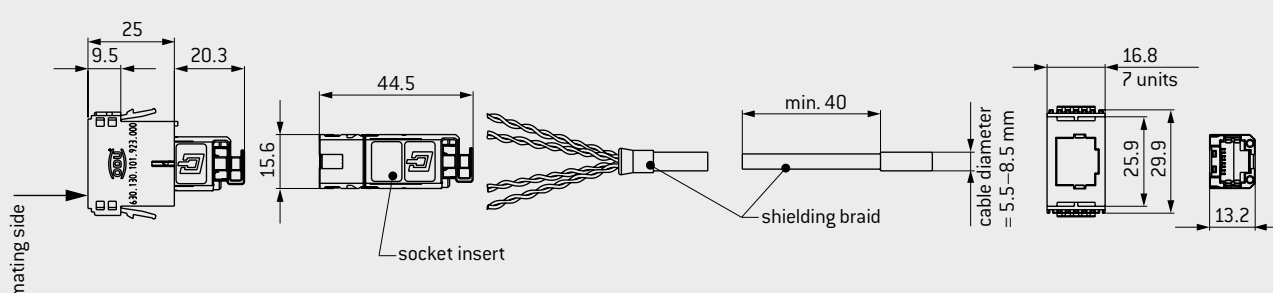

COUPLING

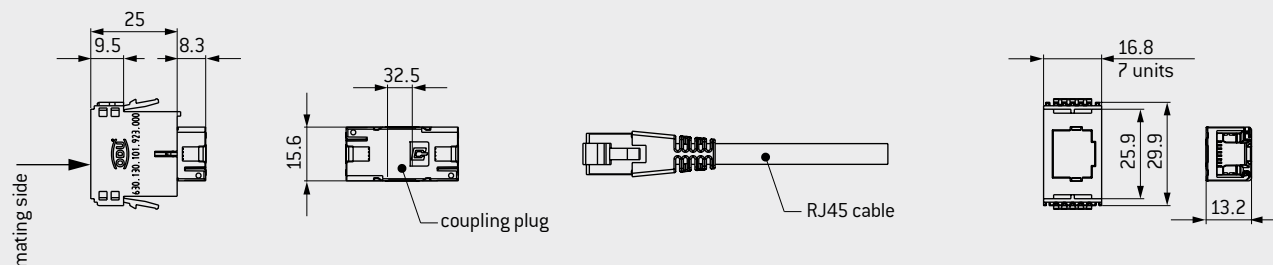

Module protection of the Ethernet¹ insert not ensured by means of guiding pins alone.
For use in a housing, check the necessary space requirements

Multi-position module	Part number
Insulator socket	630.130.101.923.000
Insulator pin	631.130.101.923.000

Description	Part number	Category	Termination
			AWG / mm
Coupling for RJ45	923.000.005.000.145		RJ45, 8 contacts
Socket insert	923.000.005.000.146	TIA A	22-26
Socket insert	923.000.005.000.147	TIA B	22-26
Socket insert	923.000.005.000.148	Profinet ^{®1}	22-26
Connector insert	923.000.005.000.149	TIAA/TIAB/Profinet ^{®1}	22-26

¹ Concerning data transmission protocols, please note page 2.

COMBINATION MODULE FOR HIGH-SPEED AND COAX 50 Ω/75 Ω

Size 1



Mating cycles: min. 10,000
 Frequency range: 0–4 GHz
 USB[®] 2.0¹, USB[®] 3.1 Gen1¹, FireWire^{®1}, Ethernet¹

TECHNICAL NOTES

- Note for high-speed module, see page [138–141](#)
- For crimp information for coax modules, see from page [154](#)

HOW TO CONFIGURE YOUR COMBINATION MODULE

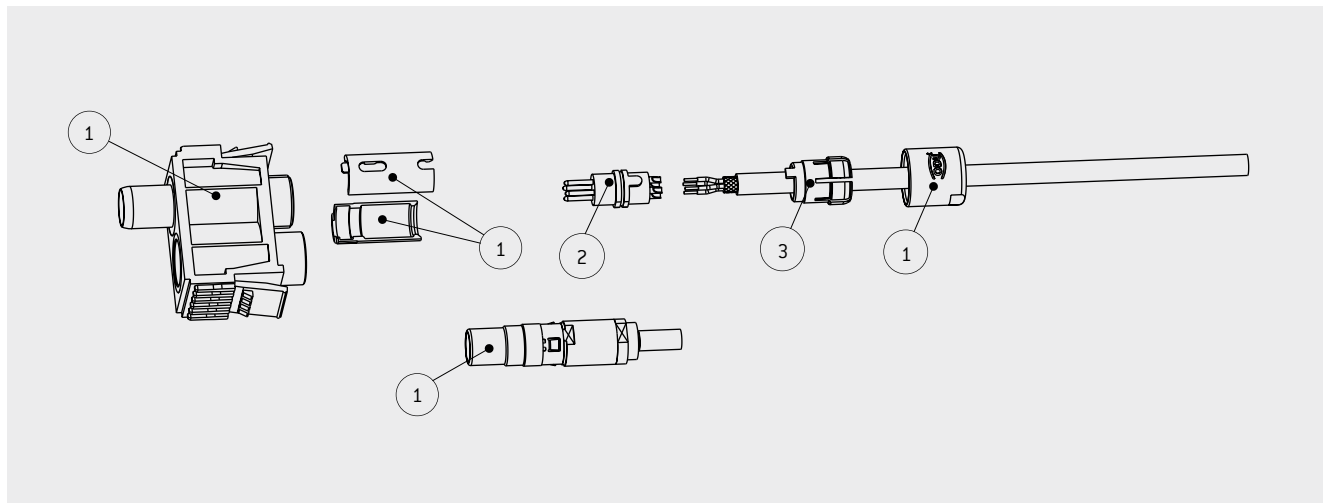

ASSEMBLY SET

Order	Base parts	Part number
1	Insulator incl. housing and coax contact 50 Ω/75 Ω	See next page
2	Insert for shielded feedthrough cpl. solder contacts ²	See page 138–141
3	Assembly set	See table on the right

Cable-Ø mm	Part number
1.5 to 2.1	751.020.188.304.022
2 to 3.2	751.020.188.304.032
3 to 4.2	751.020.188.304.042
4 to 5.2	751.020.188.304.052
5 to 6.2	751.020.188.304.062
6 to 7.2	751.020.188.304.072
7 to 7.7	751.020.188.304.077

¹Concerning data transmission protocols, please note page [2](#). ²Insert for crimp contacts on request



COAX 50 Ω

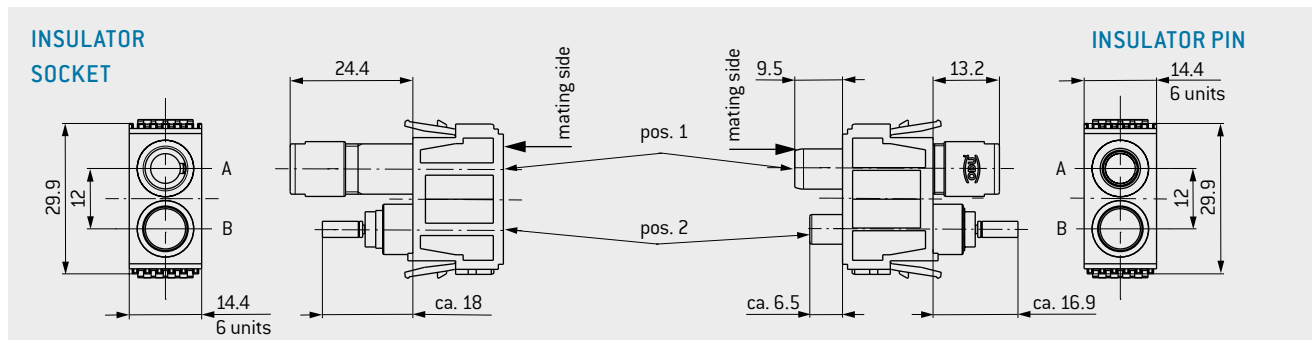

Description	Part number	Characteristic impedance Ω	Frequency range GHz	Cable ¹	Cable termination ²				Part number Crimp dies
					A	B	C	D	
Socket side	630.131.102.923.321	50	0.2	RG 179, RG 196	1.1	1.7	2.25	3.2	082.000.039.101.000
Pin side	631.131.102.923.321								
Socket side	630.131.102.923.322	50	0.4	RG 174, RG 188, RG 316	1.75	2.7	3.2	3.8	082.000.039.102.000
Pin side	631.131.102.923.322								
Socket side	630.131.102.923.323	50	3.5	RG 58	3.15	4.5	5.2	6.15	082.000.039.106.000
Pin side	631.131.102.923.323								
Socket side	630.131.102.923.325	50	4	RG 223	3.15	4.5	5.9	6.75	082.000.039.108.000
Pin side	631.131.102.923.325								

COAX 75 Ω

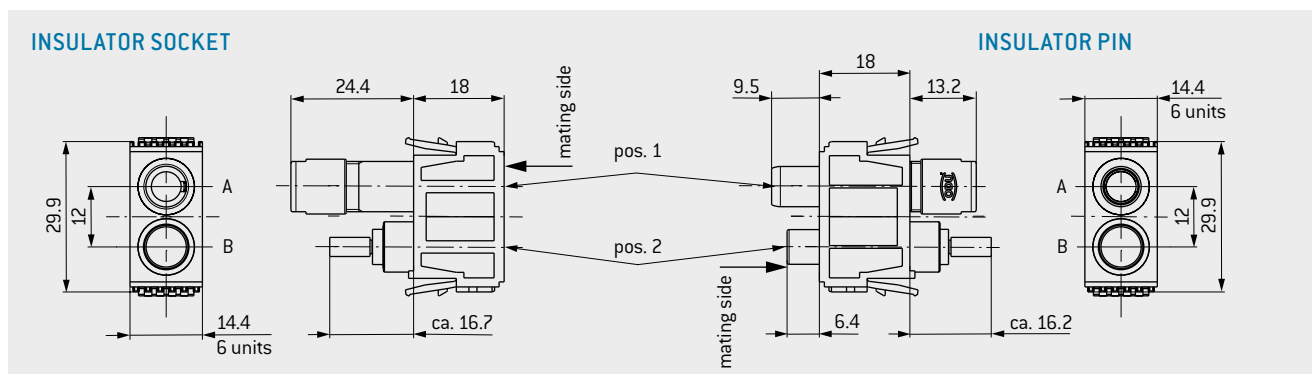

Description	Part number	Characteristic impedance Ω	Frequency range GHz	Cable ¹	Cable termination ³				Part number Crimp dies
					A	B	C	D	
Socket side	630.131.102.923.311	75	1.2	RG 179, RG 187	1.75	2.7	3.2	3.8	082.000.039.102.001
Pin contact	631.131.102.923.311								
Socket contact	630.131.102.923.312	75	2.7	RG 59	4	5.4	6.3	7.2	082.000.039.109.000
Pin contact	631.131.102.923.312								

¹Special line on request ²See page 125 ³See page 129

COMBINATION MODULE FOR HIGH-SPEED AND COMPRESSED AIR/EASILY INTERCHANGEABLE

Size 1

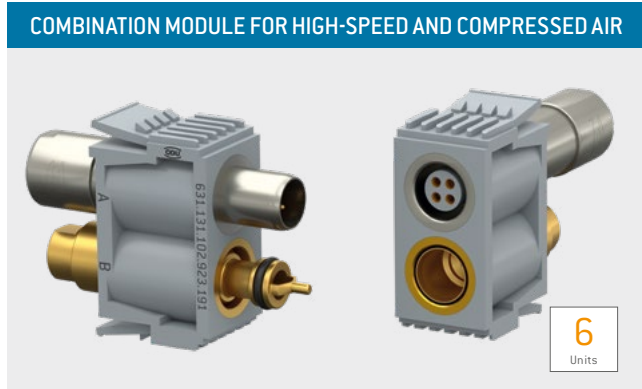

Mating cycles¹: min. 10,000
 USB® 2.0², USB® 3.1 Gen1², FireWire®²,
 Ethernet²
 12 bar or 0–4 GHz

TECHNICAL NOTES

- Note for high-speed module, see page [138–141](#)

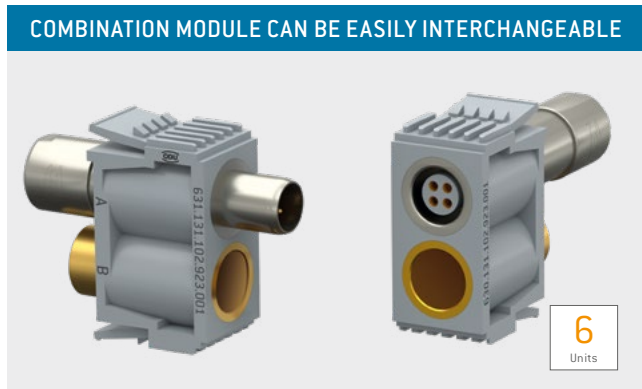

COMBINATION MODULE FOR HIGH-SPEED AND COMPRESSED AIR

- The function dictates that contacts are pre-stressed in the mated state. The frame must maintain this pre-stress with a holding device.
- Vacuum modules and further termination types on request
- No O₂ model³
- Termination accessories, see page [136](#)

COMBINATION MODULE CAN BE EASILY INTERCHANGEABLE

- Can be retrofitted with 50 Ω coax contact, see page [124–125](#)
- Can be retrofitted with 75 Ω coax contact, see page [128–129](#)
- Can be retrofitted with compressed air, see page [130–131](#)

HOW TO CONFIGURE YOUR COMBINATION MODULE FOR HIGH-SPEED AND COMPRESSED AIR

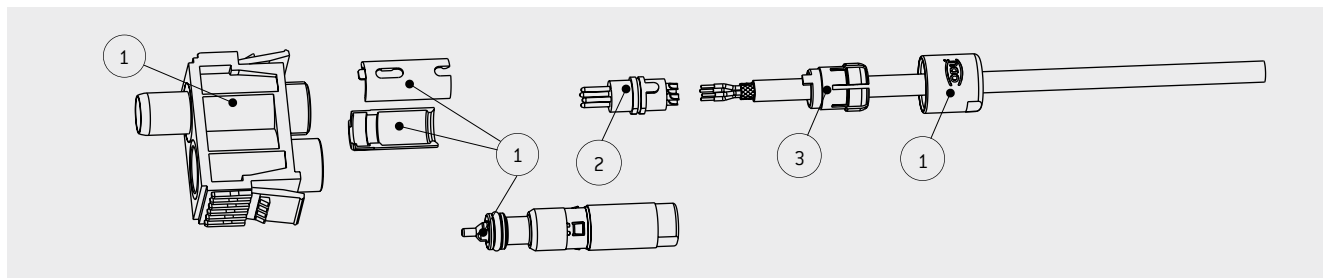

ASSEMBLY SET

Order	Base parts	Part number
1	Insulator incl. housing and compressed air/easily interchangeable	See next page
2	Insert for shielded feedthrough cpl. solder contacts ⁴	See page 138–141
3	Assembly set	See table on the right

Cable-∅ mm	Part number
1.5 to 2.1	751.020.188.304.022
2 to 3.2	751.020.188.304.032
3 to 4.2	751.020.188.304.042
4 to 5.2	751.020.188.304.052
5 to 6.2	751.020.188.304.062
6 to 7.2	751.020.188.304.072
7 to 7.7	751.020.188.304.077

¹ The stated mating cycles for compressed air module are possible via regular maintenance intervals ² Concerning data transmission protocols, please note page 2. ³ Not suitable for mixtures with over 25% oxygen content or explosive gases. ⁴ Insert for crimp contacts on request



COMBINATION MODULE FOR HIGH-SPEED AND COMPRESSED AIR

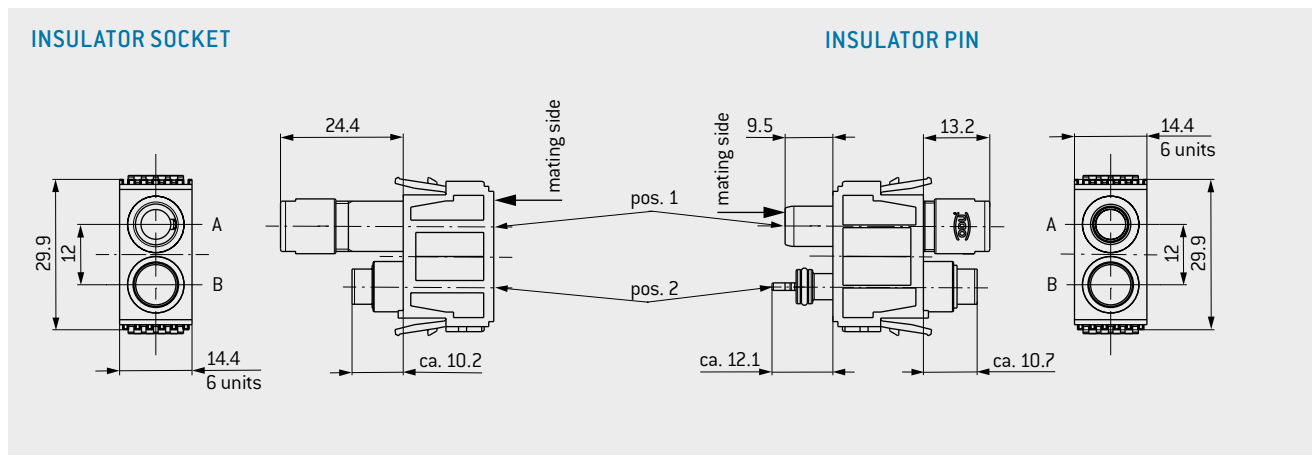

Description	Part number	Termination
Socket side (non shut-off)	630.131.102.923.191	M5
Pin side (non shut-off)	631.131.102.923.191	
Socket side (shut-off)	630.131.102.923.192	

COMBINATION MODULE CAN BE EASILY INTERCHANGEABLE

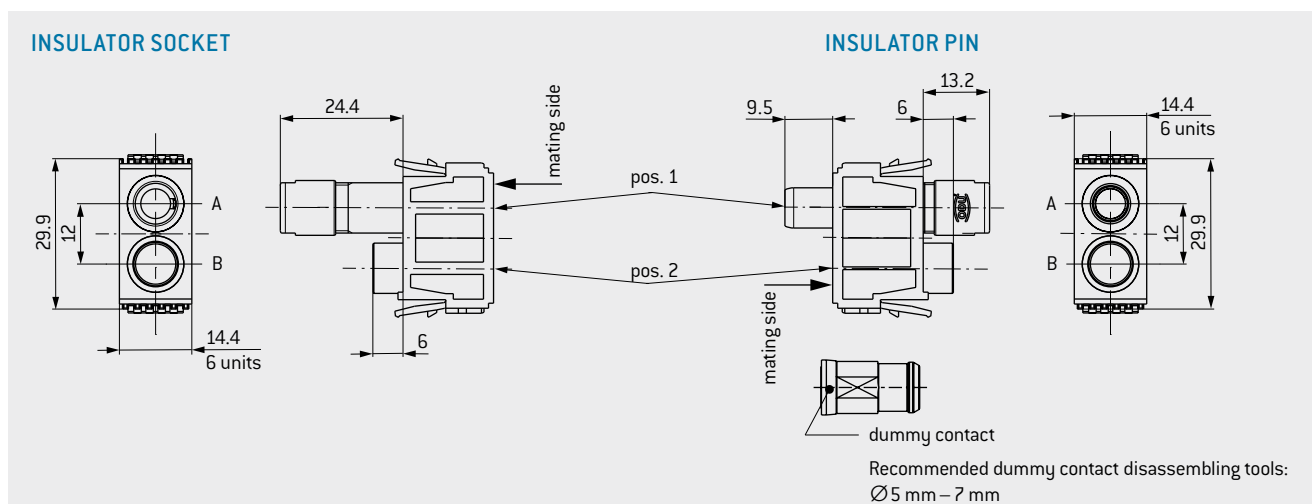

Description	Part number
Socket side	630.131.102.923.001
Pin side	631.131.102.923.001
Dummy contact	021.341.204.946.000

MODULE 2 CONTACTS FOR GLASS-FIBER CONTACTS GOF

On request

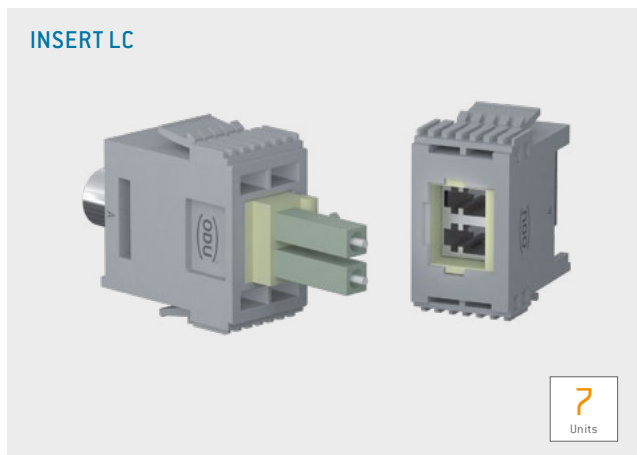
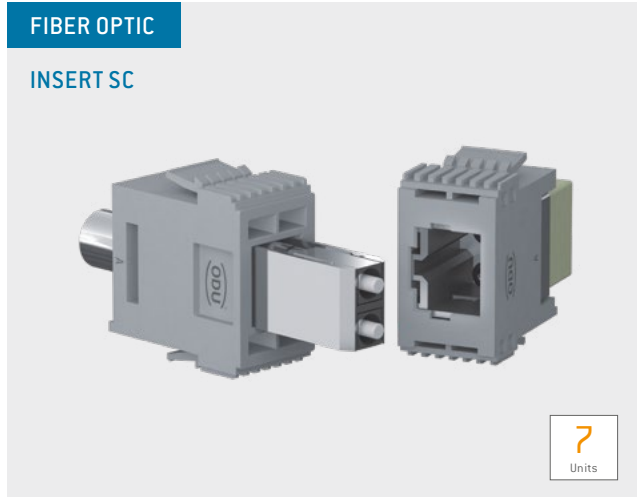

Ferrule
Single mode (SM)/multi mode (MM)
Mating cycles¹: min. 10,000

TECHNICAL NOTES

- The function dictates that contacts are pre-stressed in the mated state. The frame must maintain this pre-stress with a holding device.
- Please note that the polished surface of the contact must not be touched. When in an unmated condition, the contact must also be protected from dust and dirt.

TECHNICAL DATA

Mating cycles¹ min. 10,000

INSERTS SC

Ferrule zirconia
 SM: 125.5 µm + 1 µm
 MM: 127 µm + 4 µm

Optical features

Insertion loss SM: max. 0.5 dB
 MM: max. 0.4 dB
 Return loss SM: min. 40 dB
 MM: min. 30 dB
 Temperature range -40 °C to +70 °C
 Cable outer diameter 5 mm to 8 mm

INSERTS LC

Ferrule zirconia
 SM: 125.5 µm + 1 µm
 MM: 127 µm + 4 µm

Optical features

Insertion loss SM: max. 0.5 dB
 MM: max. 0.4 dB
 Return loss SM: min. 40 dB
 MM: min. 30 dB
 Temperature range -40 °C to +70 °C
 Cable outer diameter 5 mm to 8 mm

¹The stated mating cycles are possible if regular maintenance intervals are observed

MODULE 2 CONTACTS FOR PLASTIC FIBER POF/MOST

On request



FIBER OPTIC



Ferrule

Mating cycles: min. 10,000

Type of plastic fiber: POF/MOST

TECHNICAL NOTES

- The function dictates that contacts are pre-stressed in the mated state. The frame must maintain this pre-stress with a holding device.

TECHNICAL DATA

Mechanical data

POF (polymer optical fiber)	1 mm
Outer diameter	2.2 mm–2.3 mm
Fiber fastening	clamping
Insertion loss	
Typical	1.5 dB at 670 nm
Over entire service life	< 2 dB at 670 Nm
Total mating force (average)	16.0 N
Operating temperature (depending on fiber)	
Standard fiber	–40 °C to +85 °C
High-temperature fiber	–40 °C to +115 °C
Mating cycles	min. 10,000

Materials

Insulator	thermoplastic acc. to UL94 glass-fiber reinforced acc. to UL 94
Fiber-optic contact	Cu alloy
Type of fiber	plastic fiber 980/1.000 (POF) or 980/1.550 (MOST)

BLANK MODULES



BLANK MODULES



Used to fill incomplete frames.
The frames must be fully equipped with insulators or blank modules.

TECHNICAL DATA

Insulator thermoplastic acc. to UL 94

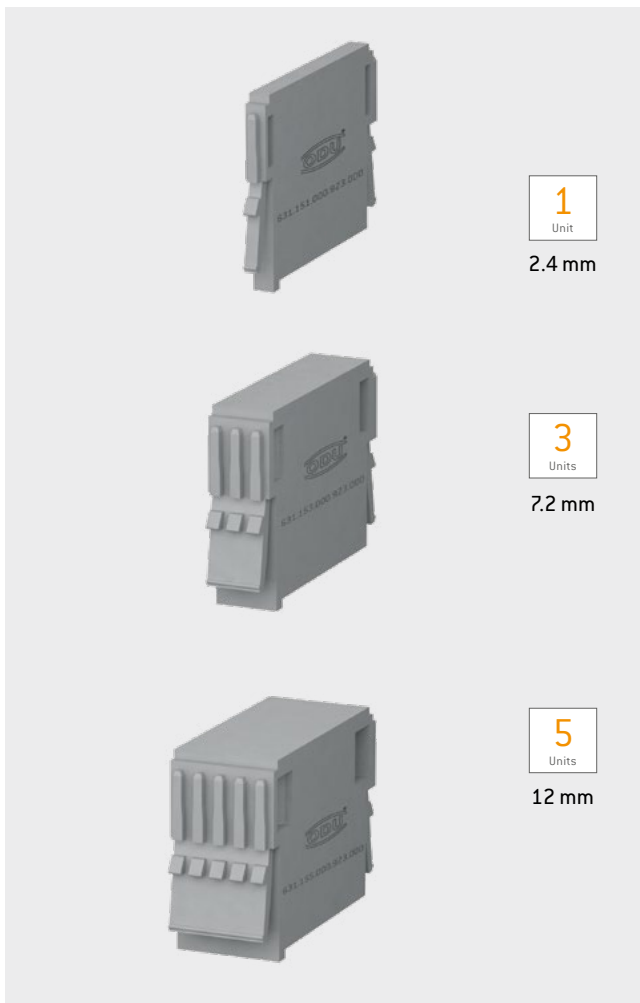

Units	Part number
1	631.151.000.923.000
3	631.153.000.923.000
5	631.155.000.923.000

FOR YOUR NOTES

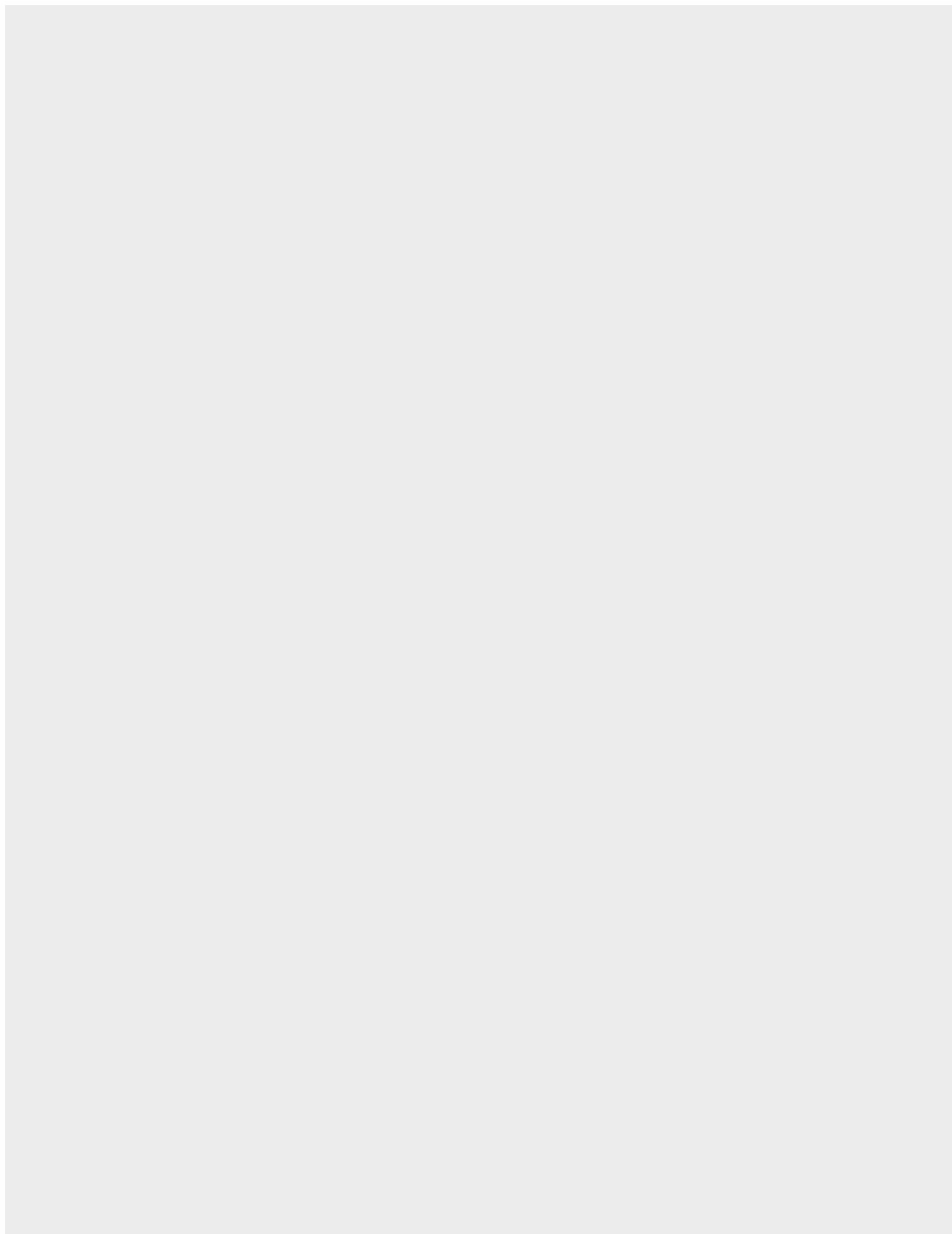

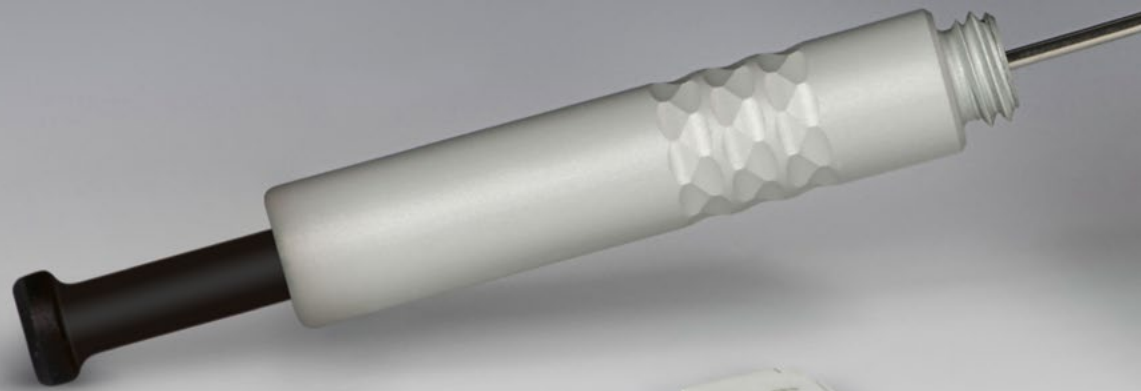

ODU-MAC[®]

[Table of contents](#)

TERMINATION TECHNOLOGY



ODU offers three different termination technologies for the single contacts:

- Crimp
- Solder
- PCB

CRIMP TERMINATION

The contact processing for the production of connecting cables via crimping creates a secure, durable, and corrosion-free contact. For most people, crimping is easy and quick to carry out.

Through crimping, the conductor and contact materials in the compressed areas become so dense as to create a connection which is nearly gas-proof, and with a tensile strength befitting the conductor material.

Crimping can be carried out on the tiniest of crosssections as well as on larger crosssections. For small crosssections ($0.14\text{--}2.5\text{ mm}^2$), 8-point crimping tools are used; hexagonal crimping tools are used for larger crosssections. The corner measurement of the crimping is never larger than the original diameter. The cable insulation is not damaged in the process and can be directly attached to the connector end.

For error-free crimping, the bore diameter must be perfectly fitted to the cable. Such error-free crimping is only guaranteed if using ODU-recommended crimping tools. In order to correctly advise you, we need to know your cable type and cable cross-section, preferably by means of a sample and corresponding data sheet.



FOR ASSEMBLY INSTRUCTIONS, PLEASE REFER TO OUR WEBSITE: WWW.ODU-CONNECTORS.COM

CRIMPING TOOLS



For further crimp information, please refer to the table on page [157](#).

8-POINT CRIMPING TOOL FOR CONDUCTOR CONNECTIONS FROM 0.08 TO 1 mm²



With user-friendly digital display
PART NUMBER: 080.000.051.000.000

POSITIONER FOR CONTACT DIAMETER FROM 0.7 TO 2 mm
PART NUMBER: 080.000.051.101.000
 Has to be ordered separately

8-POINT CRIMPING TOOL FOR CONDUCTOR CONNECTIONS FROM 1.5 TO 2.5 mm²



With user-friendly digital display
PART NUMBER: 080.000.057.000.000

POSITIONER FOR CONTACT DIAMETER FROM 2 TO 3.5 mm
PART NUMBER: 080.000.057.101.000
 Has to be ordered separately

HEXAGONAL CRIMPING TOOL FOR CROSSSECTIONS (AWG 12) FROM 4 TO 6 mm²



With blocking system
PART NUMBER: 080.000.062.000.000

MECHANICAL HEXAGONAL HAND CRIMPING TOOL FROM 10 TO 50 mm²



PART NUMBER: 080.000.064.000.000
 High pressing force with low manual force through precision mechanics. Folding head facilitates processing of unwieldy connector forms and changing of crimp dies.

CRIMPING JAWS FOR CONTACT DIAMETER FROM 5 TO 8 mm SEE PAGE [157](#).
 Has to be ordered separately

HEXAGONAL CRIMPING TOOL FOR COAX CONTACTS



With blocking system
PART NUMBER PLIER: 080.000.039.000.000

CRIMPING JAWS SEE PAGE [157](#).
 Has to be ordered separately

TENSILE STRENGTH FOR CRIMP TERMINATIONS



IEC 60352-2:2013 (DIN EN 60352-2:2014)

Tensile strength diagram of a crimp termination depending on the conductor crosssection IEC 60352-2:2013 (DIN EN 60352-2:2014)

Example: A 2.5 mm² conductor must achieve a minimum tensile strength of approx. 320 N.

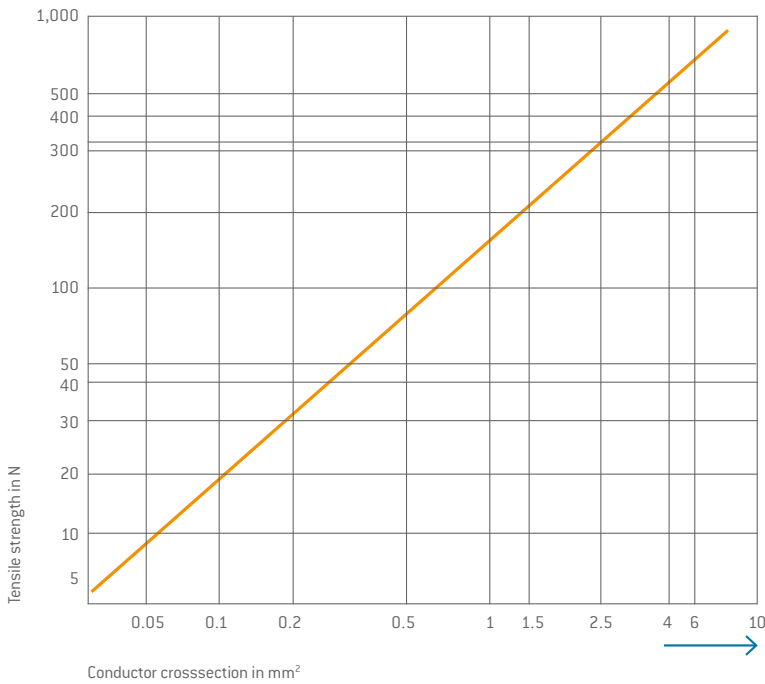

NOTE

Internal standards and guidelines are used for crosssections (> 10 mm²), as these are not clearly defined in the international standard.

TESTING ELECTRICAL CONTINUITY FOLLOWING ASSEMBLY/TESTING OF WIRING:

One of the most important functional features is the observance of the specified mating and sliding forces. All socket contacts in fully automatic systems supplied by ODU are therefore tested for 100% observance of these values in the context of process monitoring. This takes place with the correctly chosen testing systems without damage to the socket. However, ODU points out that incorrectly chosen testing systems (e.g., test

pin) or processing methods (e.g., test speed) following assembly can damage the sockets/pins. Please note the instructions in the assembly instructions (www.odu-connectors.com/downloads/assembly-instructions).

We recommend using suitable test adapters here.



CRIMP INFORMATION



Contact -Ø	Termination crosssection		Strip- ping length mm	8-point crimping tool 080.000.051.000.000 without positioner	8-point crimping tool 080.000.057.000.000 without positioner	Hexagonal crimping tool 080.000.062.000.000	Hexagonal crimping tool 080.000.064.000.000	Hexagonal crimping tool 080.000.039.000.000
	mm	AWG 7 wire 19 wire		mm ² Class 5	Positioner 080.000.051.101.000 Position/adjusting dimension	Positioner 080.000.057.101.000 Position/adjusting dimension	Crimping jaws	Crimping jaws
0.7	28	0.08	4 ^{+0.5}	0.60/9				
	26			9/0.62				
	24							
	22							
		0.14						
		0.25						
	0.38							
1.3	20		5 ^{+0.5}	10/0.92				
	18							
		0.5		10/1.02				
		0.75						
	1							
2	18		6 ^{+0.5}	11/1.22				
	16			11/1.27				
	14				3/1.67			
		1		11/1.22				
		1.5			3/1.27			
		2.5			3/1.67			
3.5	14		7 ^{+0.5}		1 ¹ , 2 ² /1.67			
	12					Profile no. 3		
	10					Profile no. 3		
		2.5			1 ¹ , 2 ² /1.67			
		4				Profile no. 3		
		6				Profile no. 3		
5		10	10 ^{+0.5}				080.000.064.110.000	
		16					080.000.064.101.000	
8		16	10 ^{+0.5}				080.000.064.116.000	
		25		18 ^{+0.5}				080.000.064.125.000

COAX CRIMP INFORMATION

		Positioner 080.000.051.102.000 Position/adjusting dimension			
RG 178 / RG 196	See module description	2/0.67 ³ 1/0.57 ⁴			082.000.039.101.000
RG 174/RG 179/RG 187/ RG 188/RG 316		2/0.67 ³ 1/0.57 ⁴			082.000.039.102.000
RG 58		2/0.92 ³			082.000.039.106.000
RG 223		2/0.67			082.000.039.108.000
RG 59		2/0.67 ³			082.000.039.109.000

¹ Pin ² Socket ³ For contacts 122.131... & 122.132... ⁴ For contacts 122.133...

ASSEMBLY AIDS



TORQUE WRENCH

With cross handle, fixed, automatic release (for inner hexagonal bits with C6.3 or E6.3 shaft).

Bit has to be ordered separately.

Description	Usage for	Part number	Nm	Recommended tightening torque
Torque wrench		598.054.001.000.000	0.9	
Torque wrench		598.054.002.000.000	1.2	
Torque wrench		598.054.006.000.000	2.2	
Torque wrench		598.054.003.000.000	3	
Bit combination slot size 2	Coding socket (DIN frame)	598.054.110.000.000		1.2 Nm +/- 0.2 Nm
Special bit	Coding pin for frames in a housing	598.054.203.000.000		1.2 Nm +/- 0.2 Nm
Bit combination slot size 1	Fastening screw on frames in a housing	598.054.102.000.000		1.2 Nm +/- 0.2 Nm
Phillips bit cross slot size 1	Oval-head screw of grounding pin on frame	598.054.106.000.000		1.2 Nm +/- 0.2 Nm
Torx bit TX 10	Screws of the securing bracket in the spindle locking and spare spindle knob	598.054.104.000.000		1.2 Nm +/- 0.2 Nm
Torx bit TX 20	Screw for power contact 12 mm contact diameter	598.054.105.000.000		2.2 Nm +/- 0.2 Nm
Assembly tool back nut size 1	Back nut for shielded feedthrough size 1	598.055.001.000.000		0.9 Nm +/- 0.2 Nm
Bit for coded spindle, slot 3 x 0.5 mm	Assembly of the spindle coding	598.054.109.000.000		0.9 Nm +/- 0.2 Nm

REMOVAL TOOLS

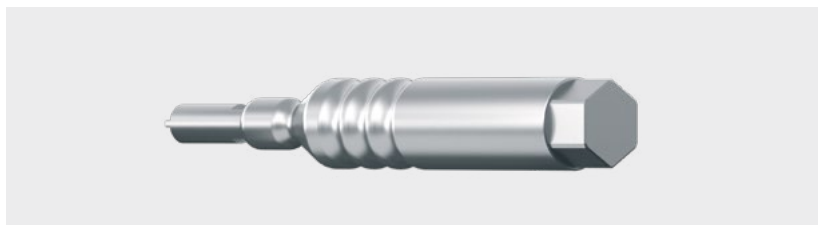

ASSEMBLY TOOL HIGH CURRENT CONTACT DIAMETER 8 mm

Required assembly tool for screwing and releasing the contacts, tightening torque: 2.7 Nm +/- 0.1 Nm

PART NUMBER: 087.611.002.001.000



REMOVAL TOOL FOR CONTACTS DIAMETER 0.7 mm

The contact is removed from the front, in the case of already assembled contacts, the cable does not have to be disconnected.

PART NUMBER: 087.7CC.070.005.000

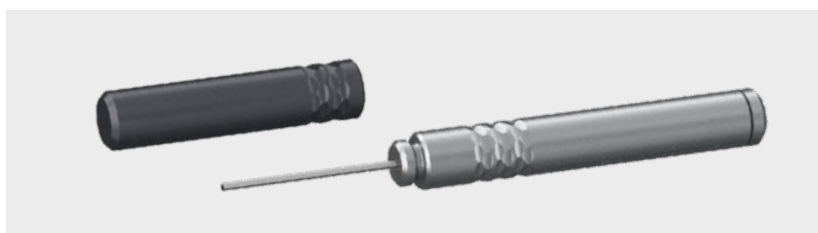

REMOVAL TOOL FOR CONTACTS DIAMETER 1.3 TO 5 mm

The contact is removed from the front, in the case of already assembled contacts, the cable does not have to be disconnected.

Contact-Ø mm	Part number
1.3	087.7CC.130.004.000
2	087.7CC.200.003.000
3.5	087.7CC.350.001.000
5	087.7CC.680.001.000



REMOVAL TOOL FOR COAX AND COMPRESSED-AIR CONTACTS

The contact is removed from the front, in the case of already assembled contacts, the cable does not have to be disconnected.

Contact	Part number
Coax 4 contacts	087.7CC.310.001.000
Coax 2 contacts	087.7CC.690.001.000
Compressed air	087.7CC.680.001.000

REMOVAL AND ASSEMBLY OF CONTACTS IS ONLY POSSIBLE WITH ODU TOOLS

REMOVAL OF CONTACTS

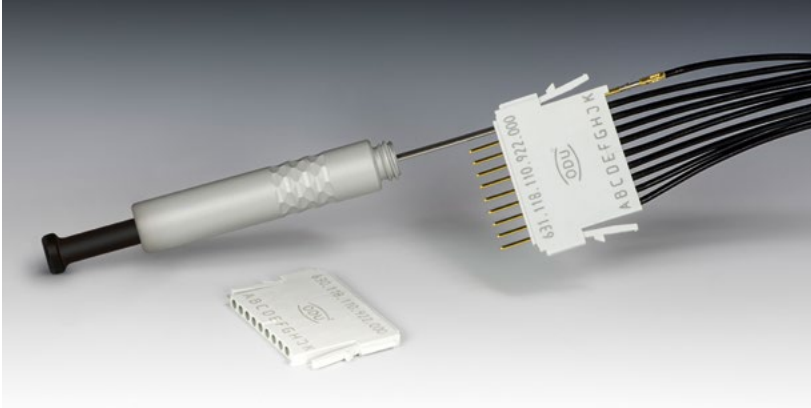

REMOVAL OF THE ASSEMBLED CONTACT

Use the conductor to push the contact to be removed to the front from behind, in order to make unlocking easier. The removal tool is pushed from the front over the contact and into the insulator until there is an audible click. By lightly pulling on the cable, the contact can be pulled from the rear of the insulator. The ODU-MAC® Blue-Line has the advantage that the contacts can also be clipped out of the module in an assembled condition without separation of the assembly.

REMOVAL OF CONTACTS IS ONLY POSSIBLE WITH ODU TOOLS

SERVICE KIT FOR ODU SPRINGTAC® AND ODU LAMTAC® CONTACTS



Contact lubrication improves the mechanical properties of contact systems. Cleaning the contact surfaces prior to lubrication is also recommended in order to remove pollution. With appropriate care, wear due to high mating frequency can be significantly minimized and the mating and demating forces reduced. The cleaning and lubricating interval must be individually adapted to circumstances and should only be carried out with products recommended by the contact manufacturer.

ODU has put together a service kit for this purpose, so that lubrication can be carried out directly on site. A cleaning brush and a special cleaning cloth, as well as precise instructions, allow for optimal care of the contacts. In the absence of other specifications, the service kit can be used for all ODU contacts and connections.

PART NUMBER: 170.000.000.000.100

For technical properties of the service kit, please refer to our website: www.odu-connectors.com/downloads

CLEANING INFORMATION

Service manual 003.170.000.000.000

FURTHER INFORMATION

Never submerge the connector in liquid. The connector may only be put back into operation again when it has been assured that it is completely dry. Ensure that contact pins are not bent or otherwise damaged. The connector must no longer be used if damage or other signs of wear are detected. Clean with maximum 2.5 bar compressed air to avoid contact damage. A slight blackening of the contact points may occur over the course of the service life and represents no impairment of the electrical properties.

Recommended cleaning agent

Soap: liquid soaps on sodium bicarbonate or potassium base
Alcohol: ethanol 70%, isopropyl alcohol 70%



ODU-MAC®













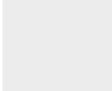

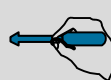

TECHNICAL INFORMATION

International Protection classes (IP) according to IEC 60529:2013 (VDE 0470-1:2014)	164
Explanations and details of safety requirements, inspections, and voltage data	165
IEC 61010-1:2010 (VDE 0411-1:2010)	168
Voltage data according to MIL	169
Conversions/AWG	170
Basic principles of current-carrying capacity	171
Current load	172
Current-carrying capacity diagram	173
Nominal current load of lines	175
Technical terms	176

INTERNATIONAL PROTECTION CLASSES

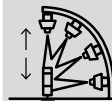

According to IEC 60529:2013 (VDE 0470-1:2014)

Code letters (International Protection)		First code number (degrees of protection against access to hazardous parts or against solid foreign objects)		Second code number (degrees of protection against water)		
IP		6		5		
Code number	Protection against access to hazardous parts/ protection against ingress of solid foreign objects			Code number	Protection against harmful effects due to the ingress of water	
0	No protection 	No protection against contact/no protection against solid foreign objects		0	No protection against water 	No protection against water
1	Protection against large foreign objects 	Protection against contact with the back of the hand/protection against solid foreign objects diameter ≥ 50 mm		1	Protection against dripping water 	Protection against vertically falling water drops
2	Protection against medium-sized foreign objects 	Protection against contact with the fingers/protection against solid foreign objects diameter ≥ 12.5 mm		2	Protection against water dripping at an angle 	Protection against water drops falling at an angle (any angle up to 15° either side of the vertical)
3	Protection against small foreign objects 	Protection against contact with tools/protection against solid foreign objects diameter ≥ 2.5 mm		3	Protection against spray water 	Protection against spray water (any angle up to 60° either side of the vertical)
4	Protection against granular foreign objects 	Protection against contact with a wire/protection against solid foreign objects diameter ≥ 1 mm		4	Protection against splashing water 	Protection against splashing water from any direction
5	Dustproof 	Protection against contact with a wire/protection against uncontrolled ingress of dust		5	Protection against water jet 	Protection against water jet from any direction
6	Dustproof 	Protection against contact with a wire/complete protection against ingress of dust		6	Protection against powerful water jet 	Protection against powerful water jet from any direction
				7	Protection against the effects of temporary immersion in water 	Protection against ingress of harmful quantities of water by temporary submersion into water
				8	Protection against the effects of continuous immersion in water 	Protection against ingress of harmful quantities of water by continuous submersion into water
				9	Protection against high-pressure water jet featuring high temperatures 	Protection against water from all directions characterized by high pressure and high temperatures



EXPLANATIONS AND DETAILS OF SAFETY REQUIREMENTS, INSPECTIONS, AND VOLTAGE DATA

GENERAL

All the technical information listed in this catalog and the data sheets has been determined by drawing on various standards. Unless otherwise stated, standard IEC 61984:2008 [VDE 0627:2009] "Connectors – Safety requirements and tests" has been used to dimension and determine the values provided.

This international standard applies to connectors (with rated voltages of 50 V to 1,000 V alternating and direct, and rated currents of up to 125 A per contact) which either have no type specification or which have a type specification whose safety requirements refer to this standard. The standard can be used as a guide for connectors with rated voltages up to 50 V. In cases such as this, IEC 60664-1:2007 must be consulted when dimensioning the clearance and creepage distances. This standard can also serve as a guide for connectors with rated currents higher than 125 A per contact.

All the connectors shown here are connectors without breaking capacity (COC) according to IEC 61984:2008 [VDE 0627:2009].

All of the voltage data listed in this catalog refers to the use of insulators, which have been installed according to assembly regulations in the ODU-MAC® frame for housings or in the ODU-MAC® docking frame. Customer-specific attachments, which could reduce the clearance and creepage distances, have not been taken into account here.

The clearance and creepage distances are determined on the bases specified in IEC 60664-1:2007 [VDE 0110-1:2008].

The most important influence variables and the electrical parameters harmonized with these will be explained in more detail in the following. We would be happy to assist you with any further questions. The texts and tables given here are excerpts from the indicated standards. As a rule, product committees lay down application-specific safety requirements for various fields of use; these requirements also regulate the insulation coordination and inspection of connectors. In such cases, the "product standards" take precedence and must be observed instead of the "basic safety standards" stated here. However, since this catalog and the technical data sheets cannot take all product standards into consideration, we have restricted ourselves to the following standard in terms of voltage data:

IEC 60664-1:2007 (VDE 0110-1:2008) "INSULATION COORDINATION FOR EQUIPMENT WITHIN LOW-VOLTAGE SYSTEMS"

This is what is known as a **basic safety standard**, which regulates the minimum requirements for dimensioning clearance and creepage distances, as well as their inspection. The standard applies to equipment used up to an altitude of 2,000 m above sea level and with a rated alternating voltage of up to 1,000 V and a nominal frequency of up to 30 KHz or a rated direct voltage of up to 1,500 V. It applies in those cases where corresponding product standards do not define any values for clearance and creepage distances, nor lay down any requirements for solid insulation, or where no product standards are even available.

The permissible overvoltage and the rated voltage may be significantly influenced by the use of blank modules and varying positioning of the contacts in the insulators.

The following general specifications have been defined for dimensioning:

- **Isolation** between electrical circuits (functional insulation between the contacts) or between an electrical circuit and local ground (contact with grounded frame) has been dimensioned as **basic insulation**. If "**double insulation**" or "**reinforced insulation**" is required, the voltage data provided may no longer apply; insulating clearances may need to be extended.
- Unless otherwise stated, all voltages are given as rms voltage values.
- **Overvoltage category III** is used, along with the TT and TN system types, to dimension the rated surge voltage.
- Condition A is always used for the inhomogeneous field when dimensioning the clearance distances used.
- The inspections prescribed for solid insulation and for clearance distances (if necessary) are conducted as alternating voltage inspections according to Table F.5.
- The clearance and creepage distances are determined on the bases specified in this standard.

OPERATING VOLTAGE/RATED VOLTAGE/ NOMINAL VOLTAGE

The **max. operating voltage** (= rated voltage) is the value of a voltage that is specified by the manufacturer for a component, device, or item of equipment according to various applicable standards, and to which the operating and performance



features relate. Some standards use the term “rated voltage” or “working voltage” instead of “operating voltage”. In these explanations, the term “nominal voltage” is used for the value of the issued voltage indicated by the power supply company (PSC) or by the manufacturer of the voltage source for classification of the overvoltage category.

Equipment may have more than one value or one range for rated voltage (see Table F.4 in IEC 60664-1:2007 (VDE 0110-1:2008)).

RATED SURGE VOLTAGE

Value of an impulse withstand voltage that is indicated by the manufacturer for equipment or a part thereof, and which indicates the defined endurance of its insulation against transient (brief, duration of a few milliseconds) overvoltages. The impulse withstand voltage is the highest value of the surge voltage of a defined form and polarity which will not result in the dielectric breakdown of the insulation under defined conditions.

Depending upon the indicated pollution degree, the rated surge voltage depends upon the clearance distance between the individual contacts (see Table F.2 in IEC 60664-1:2007 (VDE 0110-1:2008)).

According to this standard, the minimum clearance distances for equipment not connected directly to the low voltage mains should be measured according to the possible permanent voltages, the temporary overvoltages, or periodic peak voltages (see Table F.7 in IEC 60664-1:2007 (VDE 0110-1:2008)).

If a “periodic peak voltage” is present for a long time over the service life (more than approximately 60 minutes), this is not an overvoltage as regards insulation dimensioning under the terms of the standard, but must be considered a continuous voltage instead. In such cases, the “periodic peak voltage” must be used as the operating voltage.

POLLUTION DEGREE

Potentially occurring pollution combined with moisture can influence the insulation capacity on the surface of the connector. In order to define various rating parameters, a pollution degree

according to the criteria listed below must be selected for the equipment.

In the case of a connector with a degree of protection of minimum IP54 IEC 60529:2013 (VDE 0470-1:2014), the insulating parts may be measured enclosed according to the standard for a low pollution degree. This also applies for mated connectors for which enclosure is ensured by the connector housing and which are only disconnected for testing and maintenance purposes.

Pollution degree 1

No or only dry, non-conductive pollution is present. The pollution has no influence. For example, computer systems and measuring instruments in clean, dry or air-conditioned rooms.

Pollution degree 2

Only non-conductive pollution is present. However, temporary conductivity due to condensation must be anticipated. For example, devices in laboratories, residential, sales, and other business areas.

Pollution degree 3

(= Standard, if no specific pollution degree is indicated)

Conductive pollution occurs or dry, non-conductive pollution that becomes conductive because of condensation must be expected. For example, devices in industrial, commercial, and agricultural operations, unheated storage areas and workshops.

Pollution degree 4

Permanent conductivity is present, caused by conductive dust, rain or moisture. For example, devices in the open air or outdoor facilities and construction machinery. Operating voltage (VDE: rated voltage): Value of a voltage that is specified by the manufacturer for a component, device or item of equipment and relates to the operating and performance features.

Depending upon the indicated pollution degree, the rated voltage is dependent upon the insulating material group of the connector and the respective creepage distances between the individual contacts.



CLEARANCE DISTANCE

The shortest distance in the air between two conductive parts.

CREEPAGE DISTANCE

The shortest distance between two conductive parts over the surface of an insulation material. The creepage distance is influenced by the pollution degree applied.

TEST VOLTAGES

The dielectric strength of the connector is confirmed according to the standard corresponding to the indicated rated surge voltage by applying the test voltage according to Table F.5 over a defined time range.

IEC 60664-1:2007 (VDE 0110-1:2008): Table F.5 – test voltages for testing clearance distances at different altitudes (the voltage levels are valid only to verify the clearance distances)

Rated surge voltage ū kV	Test surge voltage at sea level ū kV	Test surge voltage at 200 m elevation ū kV	Test surge voltage at 500 m elevation ū kV
0.33	0.357	0.355	0.350
0.5	0.541	0.537	0.531
0.8	0.934	0.920	0.899
1.5	1.751	1.725	1.685
2.5	2.920	2.874	2.808
4	4.923	4.874	4.675
6	7.385	7.236	7.013
8	9.847	9.648	9.350
12	14.770	14.471	14.025

IEC 61010-1:2010 (VDE 0411-1:2010)



“Safety requirements for electrical equipment for measurement, control, and laboratory use”

This is what is known as a type specification or product standard, which is universally applicable to all devices belonging to the application area covered by this standard. For particular types of device, these requirements are supplemented or modified by the specific requirements contained in one or more special additional parts of the standard (Part 2), which must be read in conjunction with the requirements contained in Part 1.

Devices belonging to the application area:

- Electrical test and measurement instruments: devices that test, measure, display or record electrical and/or physical variables (also applies to test instruments integrated in production processes)
- Electrical open and closed-loop control devices for industrial process control: devices that set one or more output variables to specific values
- Electrical laboratory equipment: devices that measure, display, monitor or analyze substances (may also be used outside of the laboratory)

Devices excluded from the application area:

- IEC 60065 (Audio, video and similar electronic apparatus)
- IEC 60204 (Electrical equipment of machines)
- IEC 60601 (Medical electrical equipment)

This standard defines some special cases, unlike IEC 60664-1:2007 (VDE 0110-1:2008):

Limit values for accessible parts (Section 6.3¹):

The voltages listed below are classed as dangerous and active, if certain currents (0.5 mA AC; 2.0 mA DC) are exceeded at the same time:

- Alternating voltage (AC): $U_{\text{rms}} = 33 \text{ V}$ ($U_{\text{peak}} = 46.7 \text{ V}$)
- Direct voltage (DC): $U = 70 \text{ V}$
- Wet environment $U_{\text{rms}} = 16 \text{ V AC}$ ($U_{\text{peak}} = 22.6 \text{ V}$); $U = 35 \text{ V DC}$

A general distinction is made between the supply circuit (primary circuit) and the secondary circuit, which have different values for the clearance and creepage distances.

A partial discharge test is not compulsory at voltages $> 700 \text{ V}$ here either, it is merely recommended.

¹ See corresponding section in the DIN EN 61010-1:2010 (VDE 0411-1) safety standard

VOLTAGE DATA ACCORDING TO “MIL”



EIA-364-20F:2019

“Withstanding Voltage – Test Procedure for Electrical Connectors, Sockets and Coaxial Contacts”

The withstanding voltage values stated in this catalog were determined according to the method described in EIA-364-20F:2019 “Withstanding Voltage – Test Procedure for Electrical Connectors, Sockets and Coaxial Contacts”. The inserts were tested while mated, and the test current was applied to the pin insert.

75% of the calculated dielectric withstanding voltage is used as the test voltage for further calculations. The operating voltage is 1/3 of this value.

This standard refers to IEC 60512-4-1:2003 “Connectors for electronic equipment – Tests and measurements – Part 4-1: Voltage stress tests – Test 4a: Voltage proof”.

Test voltage: dielectric withstanding voltage \times 0.75

Operating voltage: dielectric withstanding voltage \times 0.75 \times 0.33

If there are any deviations, the derating factors are to be factored in according to the applicable standards. All tests were conducted at the prescribed indoor climate and apply up to an altitude of 2,000 m.

CONVERSIONS/AWG (AMERICAN WIRE GAUGE)



Circular wire					
AWG	Diameter		Cross-section mm ²	Weight kg/km	Max. resistance Ω/km
	Inch	mm			
4/0 [259/21]	0.6010	15.300	107.0	997.00	0.17
3/0 [259/22]	0.5360	13.600	85.0	793.00	0.22
2/0 [259/23]	0.4770	12.100	67.4	628.00	0.27
1/0 [259/24]	0.4240	10.800	53.5	497.00	0.34
1 [259/25]	0.3780	9.600	42.2	395.00	0.43
2 [259/26]	0.3350	8.500	33.6	312.00	0.55
4 [133/25]	0.2660	6.800	21.1	195.00	0.87
6 [133/27]	0.2100	5.300	13.3	122.00	1.38
8 [133/29]	0.1670	4.200	8.37	76.80	2.18
10 [1]	0.1019	2.590	5.26	46.77	3.45
10 [37/26]	0.1150	2.921	4.74	42.10	4.13
12 [1]	0.0808	2.050	3.31	29.41	5.45
12 [19/25]	0.0930	2.362	3.08	27.36	5.94
12 [37/28]	0.0910	2.311	2.97	26.45	6.36
14 [1]	0.0641	1.630	2.08	18.51	8.79
14 [19/27]	0.0730	1.854	1.94	17.23	9.94
16 [1]	0.0508	1.290	1.31	11.625	13.94
16 [19/29]	0.0590	1.499	1.23	10.928	15.70
18 [1]	0.0403	1.020	0.823	7.316	22.18
20 [1]	0.0320	0.813	0.519	4.613	35.10
20 [7/28]	0.0390	0.991	0.563	5.003	34.10
20 [19/32]	0.0420	1.067	0.616	5.473	32.00
22 [1]	0.0253	0.643	0.324	2.883	57.70
22 [19/34]	0.0330	0.838	0.382	3.395	51.80
24 [1]	0.0201	0.511	0.205	1.820	91.20
24 [7/32]	0.0250	0.635	0.227	2.016	86.00
24 [19/36]	0.0270	0.686	0.241	2.145	83.30
26 [1]	0.0159	0.404	0.128	1.139	147.00
26 [7/34]	0.0200	0.508	0.141	1.251	140.00
26 [19/38]	0.0220	0.559	0.154	1.370	131.00
28 [1]	0.0126	0.320	0.0804	0.715	231.00
28 [7/36]	0.0160	0.406	0.0889	0.790	224.00
28 [19/40]	0.0170	0.432	0.0925	0.823	207.00
30 [1]	0.0100	0.254	0.0507	0.450	374.00
30 [7/38]	0.0130	0.330	0.0568	0.505	354.00
32 [1]	0.0080	0.203	0.0324	0.288	561.00
32 [7/40]	0.0110	0.279	0.0341	0.303	597.10
34 [1]	0.0063	0.160	0.0201	0.179	951.00
34 [7/42]	0.0070	0.180	0.0222	0.197	1,491.00
36 [1]	0.0050	0.127	0.0127	0.1126	1,519.00
36 [7/44]	0.0060	0.150	0.0142	0.1263	1,322.00

The American Wire Gauge (AWG) is based on the principle that the crosssection of the wire changes by 26% from one gauge number to the next. The AWG numbers decrease as the wire diameter increases, while the AWG numbers increase as the wire diameter decreases. This only applies to solid wire.

However, stranded wire is predominately used in practice. This has the advantage of a longer service life under bending and vibration as well as greater flexibility in comparison with solid wire.

Stranded wires are made of multiple, smaller-gauge wires (higher AWG number). The stranded wire then receives the AWG numbers of a solid wire with the next closest crosssection to that of the stranded wire. In this case, the crosssection of the stranded wire refers to the sum of the copper crosssections of the individual wires.

Accordingly, strands with the same AWG number but different numbers of wires differ in cross-section. For instance, an AWG 20 strand of 7 AWG 28 wires has a crosssection of 0.563 mm², while an AWG 20 strand of 19 AWG 32 wires has a cross-section of 0.616 mm².

Source: ASTM

BASIC PRINCIPLES OF CURRENT-CARRYING CAPACITY

Derating measurement method IEC 60512-5-2:2002 (DIN EN 60512-5-2:2003)



STRUCTURE OF THE BASE CURRENT-CARRYING CAPACITY CURVE

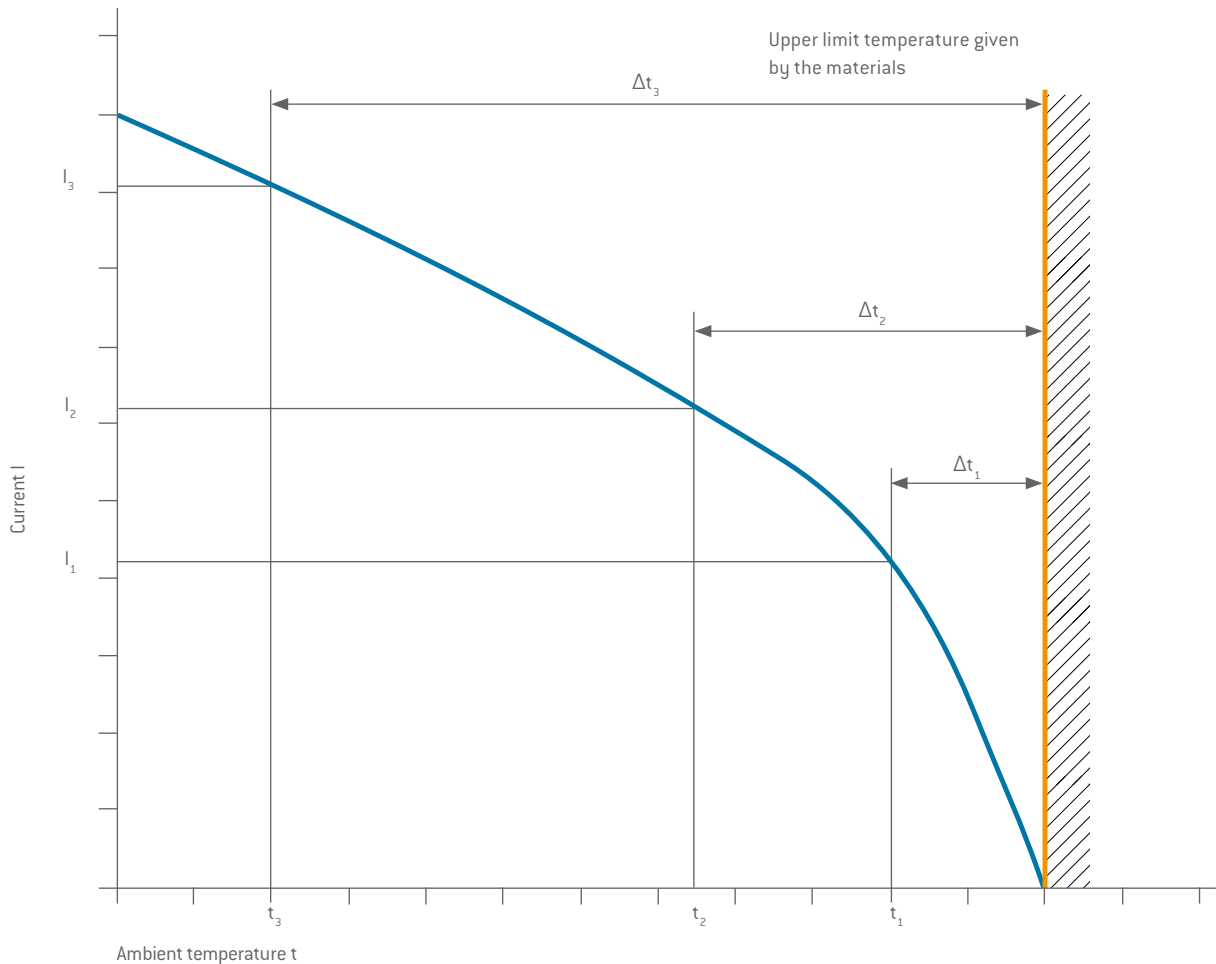

The current-carrying capacity of a connector is determined by measurement. It is determined taking self-heating by current heat and the ambient temperature into account, and is limited by the thermal properties of the contact materials used. Their upper limit temperature must not be exceeded in the process.

The relationship between current, the resulting temperature increase, conditioned by the dissipation loss at the contact resistance, and the ambient temperature is represented in a curve. The curve is plotted in a linear coordinate system with current “ I ” as Y-axis and temperature “ t ” as X-axis. The upper limit temperature forms the limit of the diagram.

Over three measurements, the temperature rise due to current heat (Δt) is measured respectively for different currents

on minimum three connectors, and the resulting values are joined to produce the parabolic basic curve. The basic curve is then used to derive the corrected current-carrying capacity curve (**derating curve**). The safety factor ($0.8 \times I_n$) also makes allowance for factors such as manufacturing tolerances and uncertainties in temperature measurement or the measuring arrangement.

CURRENT LOAD



[In dependence on VDE 0276-1000:1995]

RATED CURRENT (NOMINAL CURRENT)

The metrologically determined current which is permitted to flow continuously through all contacts at the same time and will increase the contact temperature by 45 Kelvin. The amperage is determined according to the derating measurement method (DIN EN 60512-5-2:2003) and derived from the derating curve. The values specified in the catalog apply to either single contacts or completely assembled inserts/modules, as indicated.

DERATING FACTORS

In the case of multi-position connectors and cables, the heating is greater than it is with single contacts. It is therefore calculated with a derating factor. There are no direct regulations for connectors in this context. The derating factors for multi-core cables pursuant to VDE 0298-4:2013 are applied. The derating factor assumes relevance as of 5 live cores.

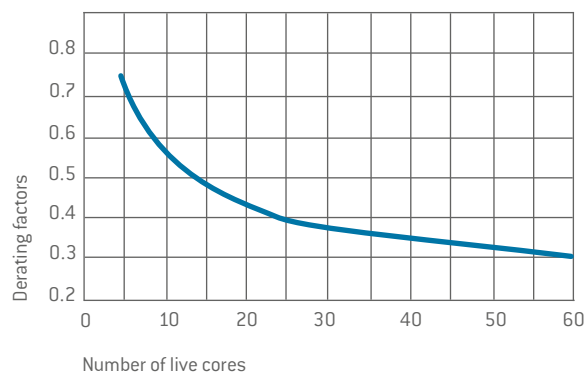

Example:

VA cable with 24 cores is used (24 contacts). The nominal crosssection of a core is 6 mm². A derating factor of 0.4 (e.g., cable installed in the open air) is to be presumed for the load reduction depending upon the number of live cable cores. A 6 mm² Cu line (contact diameter 3.0 mm) can be used according to current-carrying capacity with 39 ampere. The 24 contacts connector can thus be loaded with a max. of 15.6 A/contact (0.4 × 39 A).

MAX. CONTINUOUS CURRENT

The measured amperage at room temperature (approx. 20 °C) which increases the contact temperature to the limit temperature. The values specified in the catalog apply to either single contacts or completely assembled inserts/modules, as indicated.

Number of live cores	Derating factor
5	0.75
7	0.65
10	0.55
14	0.5
19	0.45
24	0.4
40	0.35
61	0.3

Load and derating factors

Multi-core plastic cable with conductor crosssection of 1.5 to 10 mm² when installed in the open air

NOTE

Designs may differ depending upon the wiring of the modules and be verified with a heating test.

CURRENT-CARRYING CAPACITY DIAGRAM



FOR SINGLE CONTACTS

Measurement made in acc. with IEC 60512-5-2:2002 (DIN EN 60512-5-2:2003) (derating curve shown = 0.8 × base curve)

Upper limit temperature: +120 °C

Termination with nominal crosssection

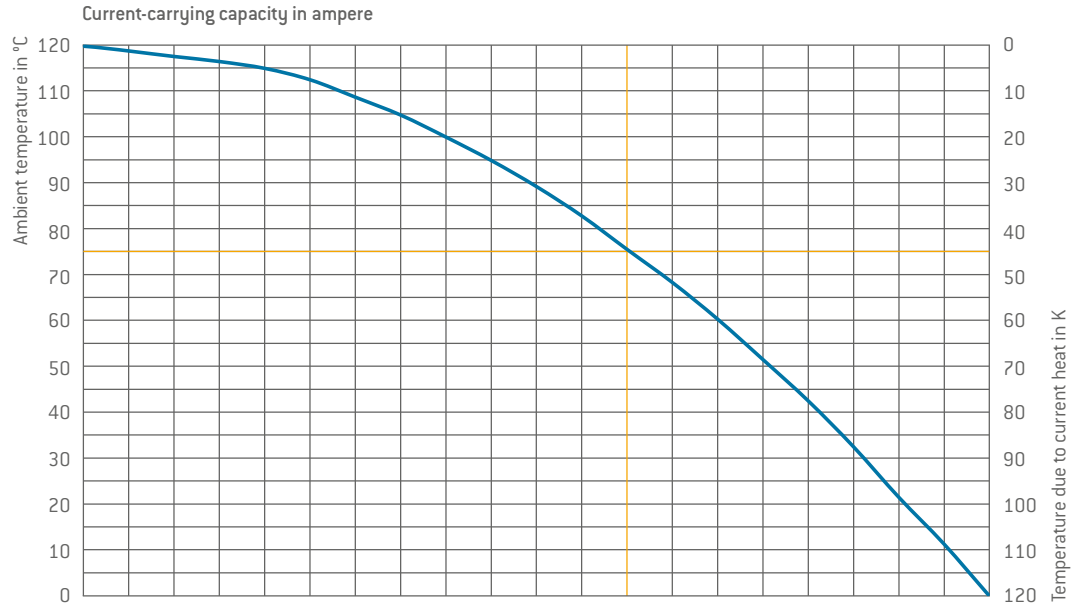

Contact	Contact- ∅	Termination crosssection mm ²	Current-carrying capacity in amperes																				
ODU TURNTAC®	0.7	0.38	0		1		2.5		3.5		5		6		7		8.5		9.5		11		12
		0.38	0	1.5	3	4.5	6	7.5	9	11	12.5	14	15.5										
	1.3	1	0		2		4		6.5		8.5		10.5		12.5		15		17		19.5		21.5
		1.5	0	3	6	9	12	15	18	21	24	27	30										
	2	2.5	0		4		8		12		16		20		24		27		30		33		37
		2.5	0	4	8	12.5	16.5	20.5	25	29	33	37	41										
3.5	4	0		6.5		13		19.5		26		32.5		39		45		51.5		58		64	
	6	0	6.5	13	19.5	26	32.5	39	45	51.5	58	64											
ODU LAMTAC®	5	10	0		10		20		29		38		47		56		67		78		90		99
		16	0	11	22	33	44	56	68	81	94	108	119										
	8	16	0		12		24		37		50		63		76		92		108		123		135
		25	0	16	33	50	67	85	103	118	135	150	165										
	12	25	0		19		38		56.5		75.5		94.5		115		132		151		172		189
		35	0	22	44	66	88.5	110.5	135	155	177	201	221										
	50	0		25		51		76		101.5		127		155		178		203		231		254	

Nominal current

Max. continuous current

CURRENT-CARRYING CAPACITY DIAGRAM



FOR FULLY EQUIPPED MODULES

Measurement made in acc. with IEC 60512-5-2:2002 (DIN EN 60512-5-2:2003) [derating curve shown = 0.8 × base curve]

Upper limit temperature: +120 °C

Termination with nominal crosssection

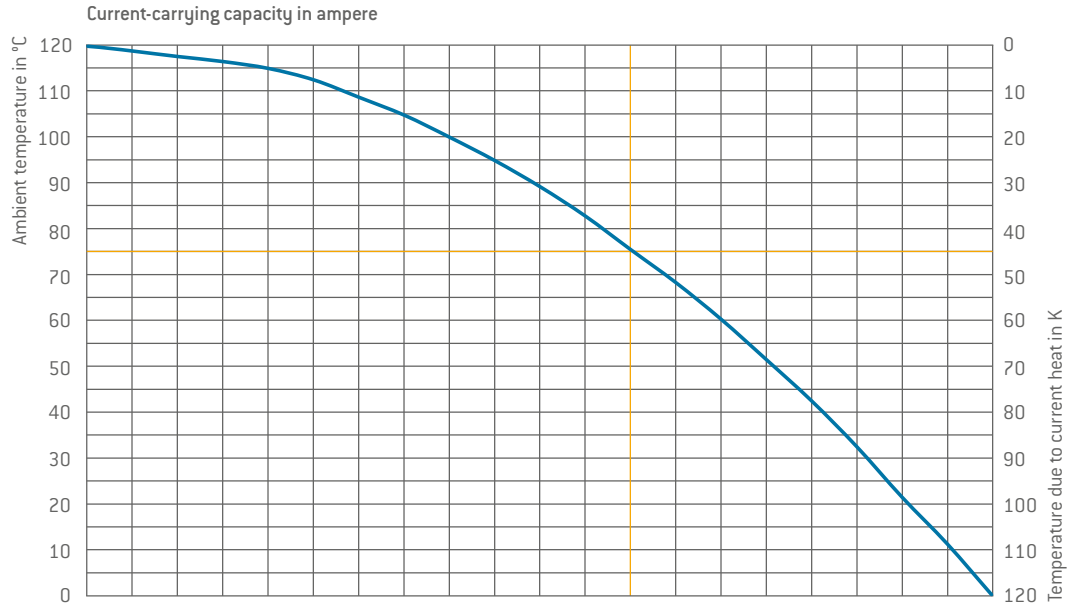

Contact	Contact- ∅	Termination crosssection mm ²	0	1	2	3	4	5	5.5	6.5	7.5	8.5	9.5
ODU TURNITAC®	0.7	0.38	0	1	2	3	4	5	5.5	6.5	7.5	8.5	9.5
		PCB	0	1	1.5	2.5	3	4	4.5	5.5	6	7	7.5
	1.3	0.38	0	1	2	3.5	4.5	5.5	7	8	9	10.5	11.5
		1	0	1.5	3.5	5.5	7.5	9.5	11.5	14	16.5	19	20.5
	2	PCB	0	1.5	2.5	4	5	6.5	8	9.5	11	12.5	14
		1.5	0	2.5	5	7.5	10	12.5	15	17.5	20	22	24
2.5		0	3	6	9	12	15	19	22	25	28	31	
3.5	PCB	0	3	5.5	8	11	13.5	16	19	22	25	27.5	
	2.5	0	3.5	7	10.5	14	17.5	21	24	27.5	31	34.5	
	4	0	5	10	15	20	25	30	34	39	44	49	
ODU LAMTAC®	5	6	0	5	10	15	20	25	30	34	39	44	49
		10	0	9	18	27	37	46	56	65	74	83	92
	8	16	0	11	22	33	45	56	68	79	90	101	112
		16	0	13	25	38	50	63	75	88	100	113	125
		25	0	17	34	50	66	83	100	116	132	149	166

Nominal current

Max. continuous current

NOMINAL CURRENT LOAD OF LINES



The current-carrying capacity of the individual conductors is frequently lower than that of the single contacts used. When determining the maximum current-carrying capacity, the lowest value is always to be taken into account.

Laying procedure	Exposed in air	Or on surfaces		
	Single-wire lines PVC, PE, PUR, TPE heat-resistant	Multi-wire highly flexible lines For hand-held devices, core/sheath cold-resistant, PVC-insulated		Multi-wire movable lines PVC, PE, PUR, TPE standard program harmonized series
Number of live cores	1	2	3	4
Nominal crosssection copper conductor in mm ²	Nominal current load in A			
0.14 ¹	3			2
0.25 ¹	5			4
0.34 ¹	8			6
0.5 ¹	12	3	3	9
0.75	15	6	6	12
1	19	10	10	15
1.5	24	16	16	18
2.5	32	25	20	26
4	42	32	25	34
6	54	40		44
10	73	63		61
16	98			82
25	129			108
35	158			135
50	198			168
Nominal current load acc. to:	VDE 0298-4:2013 Table 11			

Nominal current load of lines with a nominal voltage of up to 1,000 V and of heat-resistant lines.

The specification of data does not release one from the need to conduct the test. The original standards remain authoritative for all of the listed technical specifications.

¹ DIN VDE 0891-1:1990

TECHNICAL TERMS



AMBIENT TEMPERATURE

Temperature of the air or other medium in which a piece of equipment is intended to be used.

AWG

American Wire Gauge see page [170](#)

BASE CURVE IEC 60512-5-2:2002 (DIN EN 60512-5-2:2003)

See page [171](#)

CHEMICAL RESISTANCE

Many secondary processing procedures use glues, cleaning agents or other chemicals on our products. Contact with unsuitable chemicals may have an adverse effect on the mechanical and electrical properties of the insulation and housing materials, which specified properties may not be able to withstand. Please observe our processing suggestions and technical notes in this catalog as well as the special information for the plastic housings.

CLEARANCE DISTANCE

The shortest distance in the air between two conductive parts. The insulation coordination is explained in detail from page [165](#).

CODING (ORIENTATION)

Arrangement with which differing polarization of otherwise identical connectors prevents interchangeability. This is a good idea if two or more identical connectors are attached to the same device (see from page [76](#)).

CONNECTOR

Also known as connectors without contact rating (COC) (IEC 61984:2008 (VDE 0627:2009)). An element which enables electrical conductors to be connected and is intended to create and/or separate connections with a suitable counterpart.

CONTACT RESISTANCE

Total resistance value measured from terminal to terminal. In this case, the resistance is significantly lower than the contact resistance. The specifications are average values.

CORE

Electrical conductor, solid wire or multi-wire strand, with insulation as well as any conductive layers. Cables or lines may have one or more cores.

CREEPAGE DISTANCE

The shortest distance between two conductive parts along the surface of a solid insulation material. This factors in all elevations and recesses in the insulator, as long as defined minimum dimensions are on hand. The insulation coordination is explained in detail from page [165](#).

CRIMP BARREL

A conductor barrel which can accommodate one or more conductors and be crimped by a crimping tool.

CRIMP TERMINATION

Termination technology, see crimp connection

CRIMP CONNECTION

The permanent, non-detachable, and solder-free mounting of a contact to a conductor via shaping the crimp barrel around the conductor to make a good electrical and mechanical connection. Executed with crimping tool, press or automatic crimping machine (see page [154](#)).

CRIMPING AREA

The specified area of the crimp barrel in which the crimp termination is executed by means of deforming or shaping the barrel under pressure around the conductor.

CURRENT-CARRYING CAPACITY (NOMINAL CURRENT AND MAXIMUM CONTINUOUS CURRENT)

The data relates to adequately dimensioned connection cables according to IEC 60228:2004 (VDE 0295:2005; Class 5), so that no significant temperature increase occurs here.

The indicated temperature increase takes place through the contact. The specifications are average values.

DELIVERY FORM

The delivery of the connector is carried out in the form of individual parts.

DERATING CURVE

See page [171](#)

DERATING FACTOR

According to VDE 0298-4:2013, with connectors and cables with over 5 contacts, the heating is greater than it is with single contacts. For that reason, the aforementioned standard is calculated with a derating factor (see page [172](#)).

TECHNICAL TERMS



DERATING MEASUREMENT METHOD

IEC 60512-5-2:2002 (DIN EN 60512-5-2:2003)

See page [171](#)

INSULATOR

Part of a connector which separates conductive parts with different potentials from one another; usually identical to the contact carrier.

LUBRICATION

All standard contacts are lubricated at the factory. We recommend the service kit for ODU SPRINTAC® and ODU LAMTAC® contacts for subsequent lubrication (see page [161](#)).

MATERIALS (STANDARD DESIGN)

Pins and carriers of the sockets are manufactured from a CuZn alloy and silver or gold-plated. The lamellas consist of a CuBe alloy and are also silver or gold-plated.

MATING AND SLIDING FORCE (DEMATING FORCE)

The force required to fully insert or withdraw pluggable elements without the influence of a coupling or locking device. The higher value of the mating force is caused by the “attachment peak”. Subsequently, only the pure sliding force has an effect. The data refers to contacts in a lubricated condition (status at delivery) and after approx. 30 mating cycles. The forces are/ may be higher in new condition (lubricated). The data represents average values with a potential fluctuation of $\pm 50\%$.

MATING CYCLES

Mechanical actuation of connectors by mating and sliding. A mating cycle consists of one insertion and withdrawal action. 10,000 mating cycles are the standard value for ODU TURNTAC® and ODU LAMTAC® contacts. These values only apply under the following circumstances: clean environment, appropriate radial guidance, impeccable counterpins.

MAX. CONTINUOUS CURRENT

The metrologically determined amperage at room temperature (approx. 20 °C) which increases the contact temperature to the limit temperature. The values specified in the catalog apply to either single contacts or completely assembled inserts/modules, as indicated.

NOMINAL CURRENT IEC 60512-5-2:2002 (DIN EN 60512-5-2:2003)

See rated current.

NOMINAL SINGLE-CONTACT CURRENT LOAD

The current-carrying capacity which each individual contact can be loaded with continuously on its own (see from page [171](#)).

NOMINAL VOLTAGE

The voltage which the manufacturer specifies for a connector and relates to the operating and performance features.

OPERATING TEMPERATURE

See upper limit temperature (see page [178](#)). Single modules may differ from the indicated temperature values. Here you find the technical information on the appropriate pages.

OPERATING VOLTAGE

The nominal voltage of the power source for which the connector is being used. The operating voltage must not be higher than the nominal voltage of the connector.

PCB

A.k.a. “printed circuit board”. A PCB is a carrier for electronic components. It serves the purposes of mechanical mounting and electrical connection.

PCB TERMINATION

Production of a conductive connection between the PCB and a component in through-hole assembly, THT (through-hole technology).

POLLUTION DEGREE

The insulation coordination is explained in detail from page [165](#).

RATED CURRENT (NOMINAL CURRENT)

See from page [172](#)

RATED VOLTAGE

According to IEC 60512-5-2:2002 (DIN EN 60512-5-2:2003) standard “Value of a voltage which is specified by the manufacturer for a component, device or item of equipment and relates to the operating and performance features”.

TECHNICAL TERMS



SOLDER CONNECTION (SOLDER TERMINATION)

Termination technology in which a molten additional metal (solder) with a lower melting point than the base materials to be connected is used to attach two metallic materials to one another.

SOLDER TERMINATION

Termination technology, see solder connection

SPINDLE LOCKING

Locking of two halves of a connector pair by one or more screws, which are generally fluted or have a toggle for easier activation.

TERMINATION CROSSSECTION

The specified crosssections correspond to a “fine-wire” conductor structure according to IEC 60228:2004 (VDE 0295:2005; Class 5) or a “fine-wire” conductor structure (7/19 wire) according to AWG (ASTM B258-14).

TERMINATION TECHNOLOGIES

Methods for connecting the lines to the electro-mechanical element, such as solder-free connections according to IEC 60352-2:2013 (DIN EN 60352-2:2014): crimp termination, screw connection, etc., or soldering connection (see from page [154](#)).

TEST VOLTAGE

The voltage which a conductor can withstand under defined conditions without dielectric breakdown or flashover.

TIGHTNESS IEC 60529:2013 (VDE 0470-1:2014)

See International Protection classes on page [164](#)

UPPER LIMIT TEMPERATURE

The highest permissible temperature at which the connector may still be operated. It includes contact heating through current-carrying capacity. In the case of standard contacts (ODU TURNTAC®), this amounts to +120 °C.

WIRE

Wires (solid conductors) are available with an insulating sleeve and/or electrical shielding. Cables or conductors may be made up of one or more wires.

GENERAL NOTE

The connectors listed in this catalog are intended for use in high voltage and frequency ranges.

Suitable precautions must be taken to ensure people do not come into contact with live conductors during installation and operation.

All entries in this catalog were thoroughly reviewed before printing. ODU reserves the right to make changes based on the current state of knowledge without prior notice without being obliged to provide replacement deliveries or refinements of older designs.

FOR YOUR NOTES

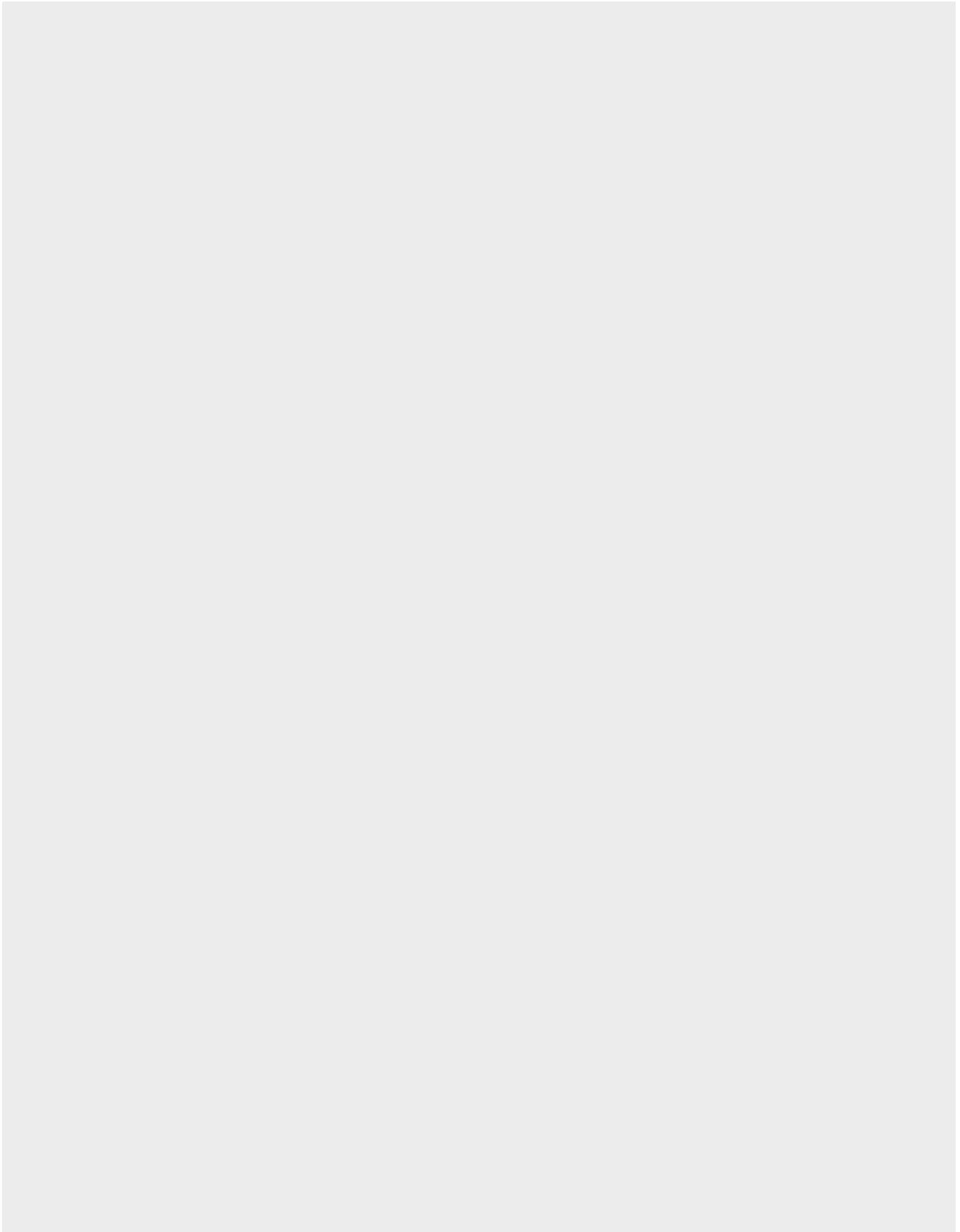

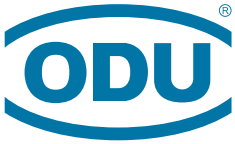

A PERFECT ALLIANCE.

ODU GROUP WORLDWIDE

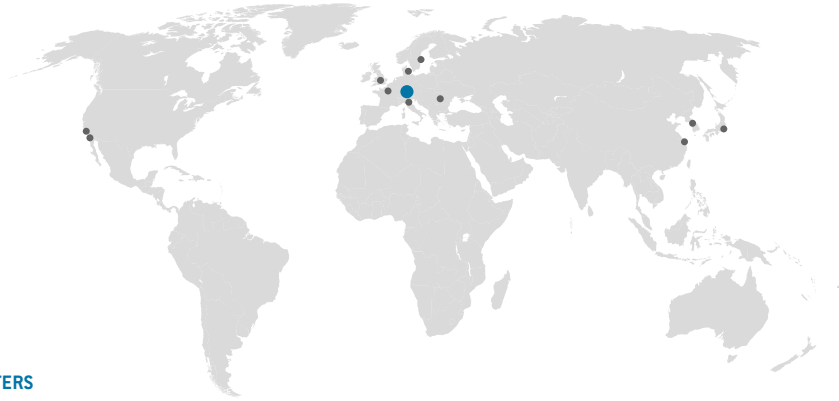

HEADQUARTERS

ODU GmbH & Co. KG

Pregelstraße 11, 84453 Mühldorf a. Inn, Germany
Phone: +49 8631 6156-0, Fax: +49 8631 6156-49, E-mail: sales@odu.de

SALES LOCATIONS

ODU (Shanghai)

International Trading Co., Ltd.
Phone: +86 21 58347828-0
E-mail: sales@odu.com.cn
www.odu.com.cn

ODU Japan K.K.

Phone: +81 3 6441 3210
E-mail: sales@odu.co.jp
www.odu.co.jp

ODU-UK Ltd.

Phone: +44 330 002 0640
E-mail: sales@odu-uk.co.uk
www.odu-uk.co.uk

ODU Denmark ApS

Phone: +45 2233 5335
E-mail: sales@odu-denmark.dk
www.odu-denmark.dk

ODU Korea Inc.

Phone: +82 2 6964 7181
E-mail: sales@odu-korea.kr
www.odu-korea.kr

ODU-USA, Inc.

Phone: +1 805 484-0540
E-mail: sales@odu-usa.com
www.odu-usa.com

ODU France SARL

Phone: +33 1 3935-4690
E-mail: sales@odu.fr
www.odu.fr

ODU Romania Manufacturing S.R.L.

Phone: +40 269 704638
E-mail: sales@odu-romania.ro
www.odu-romania.ro

Further information and specialized representatives can be found at:

www.odu-connectors.com/contact

ODU Italia S.R.L.

Phone: +39 331 8708847
E-mail: sales@odu-italia.it
www.odu-italia.it

ODU Scandinavia AB

Phone: +46 176 18262
E-mail: sales@odu.se
www.odu.se

PRODUCTION AND LOGISTICS SITES

Germany	Otto Dunkel GmbH
China	ODU (Shanghai) Connectors Manufacturing Co.Ltd
Mexico	ODU Mexico Manufacturing S.R.L. de C.V.
Romania	ODU Romania Manufacturing S.R.L.
USA	ODU North American Logistics



Simply scan the QR code to download the entire publication.

All dimensions are in mm. Some figures are for illustrative purposes only. Subject to change without notice. Errors and omissions excepted. We reserve the right to change our products and their technical specifications at any time in the interest of technical improvement. This publication supersedes all prior publications. This publication is also available as a PDF file that can be downloaded from www.odu-connectors.com

GRASWOLD, HEILIGTAC | Passau

ODU-MAC® BLUELINE / C/1005/EN

X-ON Electronics

Largest Supplier of Electrical and Electronic Components

Click to view similar products for [Headers & Wire Housings](#) category:

Click to view products by [ODU](#) manufacturer:

Other Similar products are found below :

[892-18-020-10-001101](#) [58102-G61-06LF](#) [582553-1](#) [0009485154](#) [009176003701906](#) [0050291907](#) [LY20-4P-DT1-P1E-BR](#) [02.125.8002.8](#)
[609-3404](#) [61062-3](#) [61082-181009](#) [622-3653LF](#) [63453-116](#) [636-1030](#) [636-1427](#) [636-3427](#) [636-4007](#) [641938-9](#) [641991-4](#) [644827-2](#) [65817-](#)
[010LF](#) [65817-015LF](#) [65863-015LF](#) [66207-023LF](#) [67095-007LF](#) [67601157](#) [68645-018](#) [68648-049](#) [70.362.1628.0](#) [70-4210](#) [70-4226B](#) [70-](#)
[4853B](#) [707-5020](#) [707-5028](#) [71.350.2428.0](#) [71918-208LF](#) [71961-016LF](#) [733-134](#) [733-162](#) [754199-000](#) [760-3052](#) [787-8014-00](#) [79531-3000](#)
[FCN-360C032-B](#) [FCN-367T-T012/H](#) [FCN-723D010/2](#) [80.063.4001.1](#) [800-90-001-10-001000](#) [800-90-010-10-002000](#) [801-43-002-10-013000](#)