

# S32K312MINI-EVB

Cost effective Evaluation Board for S32K312 MCUs  
Hardware User Manual

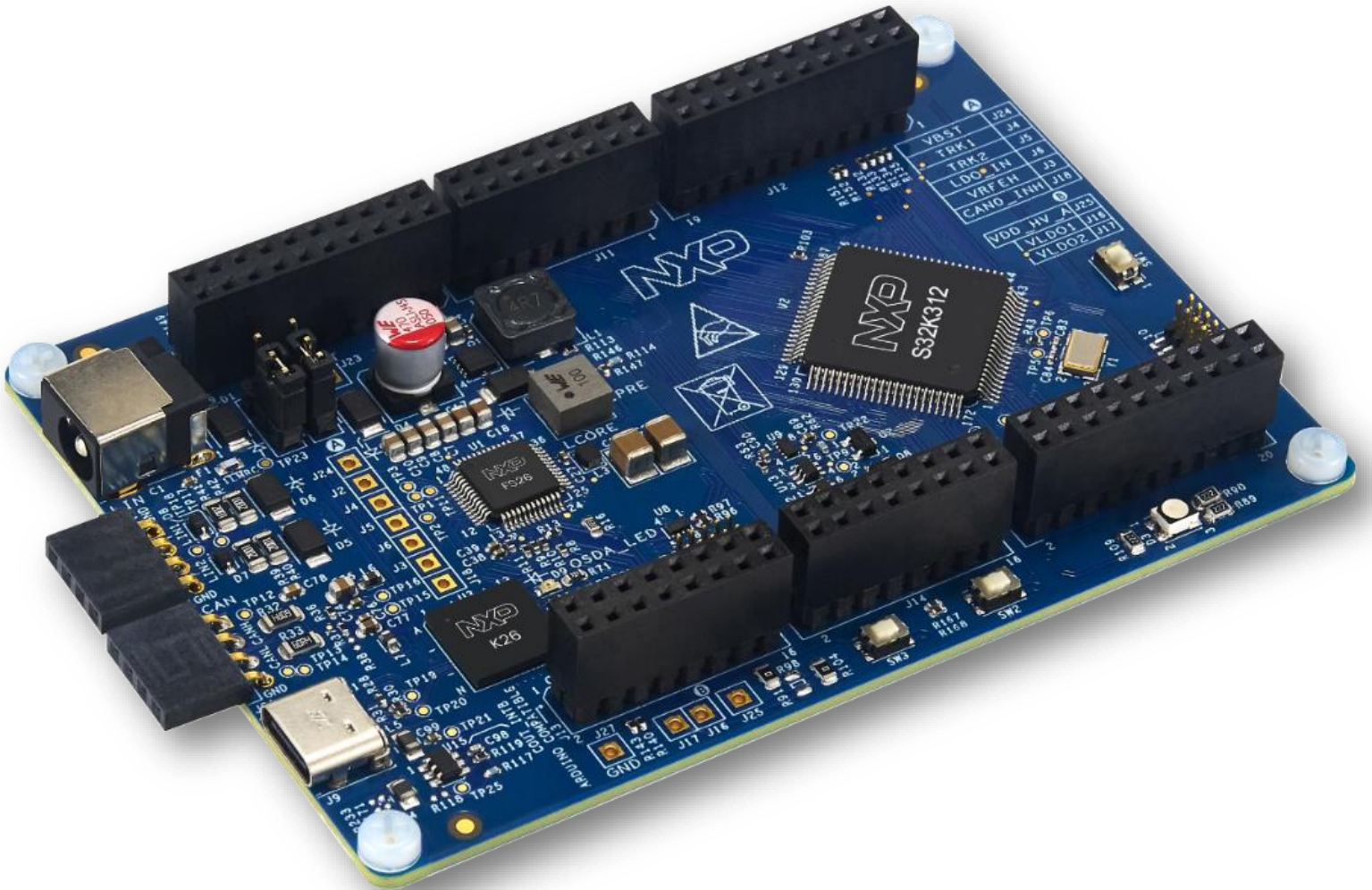

# 1 Table of contents

---

<b>1</b>	<b>Table of contents</b> .....	<b>2</b>
<b>2</b>	<b>Definitions, Acronyms, and Abbreviations</b> .....	<b>3</b>
<b>3</b>	<b>S32K312MINI-EVB – Block Diagram</b> .....	<b>4</b>
<b>4</b>	<b>S32K312MINI-EVB – Features</b> .....	<b>5</b>
<b>5</b>	<b>S32K312MINI-EVB – Default Configuration</b> .....	<b>6</b>
<b>6</b>	<b>S32K312MINI-EVB – Power Supply</b> .....	<b>7</b>
6.1	S32K312MINI-EVB – Supply options .....	7
6.2	S32K312MINI-EVB – Start-up sequence .....	8
6.3	S32K312MINI-EVB – Voltage references.....	10
<b>7</b>	<b>S32K312MINI-EVB – Programming and Debug Interface</b> .....	<b>13</b>
7.1	S32K312MINI-EVB – RESET Switch and LED indicator.....	13
7.2	S32K312MINI-EVB – JTAG .....	14
7.3	S32K312MINI-EVB – On board Debugger .....	15
<b>8</b>	<b>S32K312MINI-EVB – LIN Interface</b> .....	<b>15</b>
<b>9</b>	<b>S32K312MINI-EVB – CAN Interface</b> .....	<b>17</b>
<b>10</b>	<b>S32K312MINI-EVB – User Peripherals</b> .....	<b>19</b>
10.1	S32K312MINI-EVB – RGB LED Indicator .....	19
10.2	S32K312MINI-EVB – User Pushbuttons .....	19
<b>11</b>	<b>Pinout assignment</b> .....	<b>20</b>
<b>12</b>	<b>S32K312MINI-EVB – Revision history</b> .....	<b>23</b>
<b>13</b>	<b>Legal Information</b> .....	<b>24</b>
13.1	Definitions .....	24
13.2	Disclaimers.....	24
13.3	Trademarks .....	24

## 2 Definitions, Acronyms, and Abbreviations

The following list defines the abbreviations used in this document.

BST	Boost
CCM	Counter with CBC MAC (Cipher block chaining message authentication code)
CMOS	Complementary Metal Oxide Semiconductor.
CP	Charge Pump
CPU	Central Processing Unit.
CSPI	Configurable Serial Peripheral Interface.
DDR	Double Data Rate.
DIP	Dual In-line Package.
DPGA	Differential Programmable Gain Amplifier
EEPROM	Electrically Erasable Programmable Read Only Memory.
EPROM	Erasable Programmable Read Only Memory.
FET	Field-Effect Transistor
GCTL	Gate Control
GDU	Gate Driver Unit
GPIO	General Purpose Input/output.
GPO	General Purpose Output.
HG	High-side Gate
HS	High-side Source
HW	Hardware.
HVI	High Voltage Input
HVM	High Voltage Module
I2C	Inter-Integrated Circuit.
I/O	Input/output.
JTAG	Joint Test Access Group.
LED	Light Emitting Diode.
LG	Low-side Gate
LPM	Low-Power Mode
LS	Low-side Source
MB	Megabyte.
MCU	Microcontroller Unit.
MOSFET	Metal-Oxide-Semiconductor Field-Effect Transistor
MS	Memory Stick.
NVRAM	Non-volatile Random-Access Memory.
PCB	Printed Circuit Board.
PHY	Physical interface.
PMC	Power Management Controller
POR	Power-on Reset.
PSRAM	Pseudo Random Access Memory.
PWR	Power.
PWM	Pulse Width Modulation.
RAM	Random Access Memory.
SDRAM	Synchronous Dynamic Random-Access Memory.
TFT	Thin Film Transistor.
UART	Universal Asynchronous Receiver/Transmitter.
USB	Universal Serial Bus.

## 3 S32K312MINI-EVB – Block Diagram

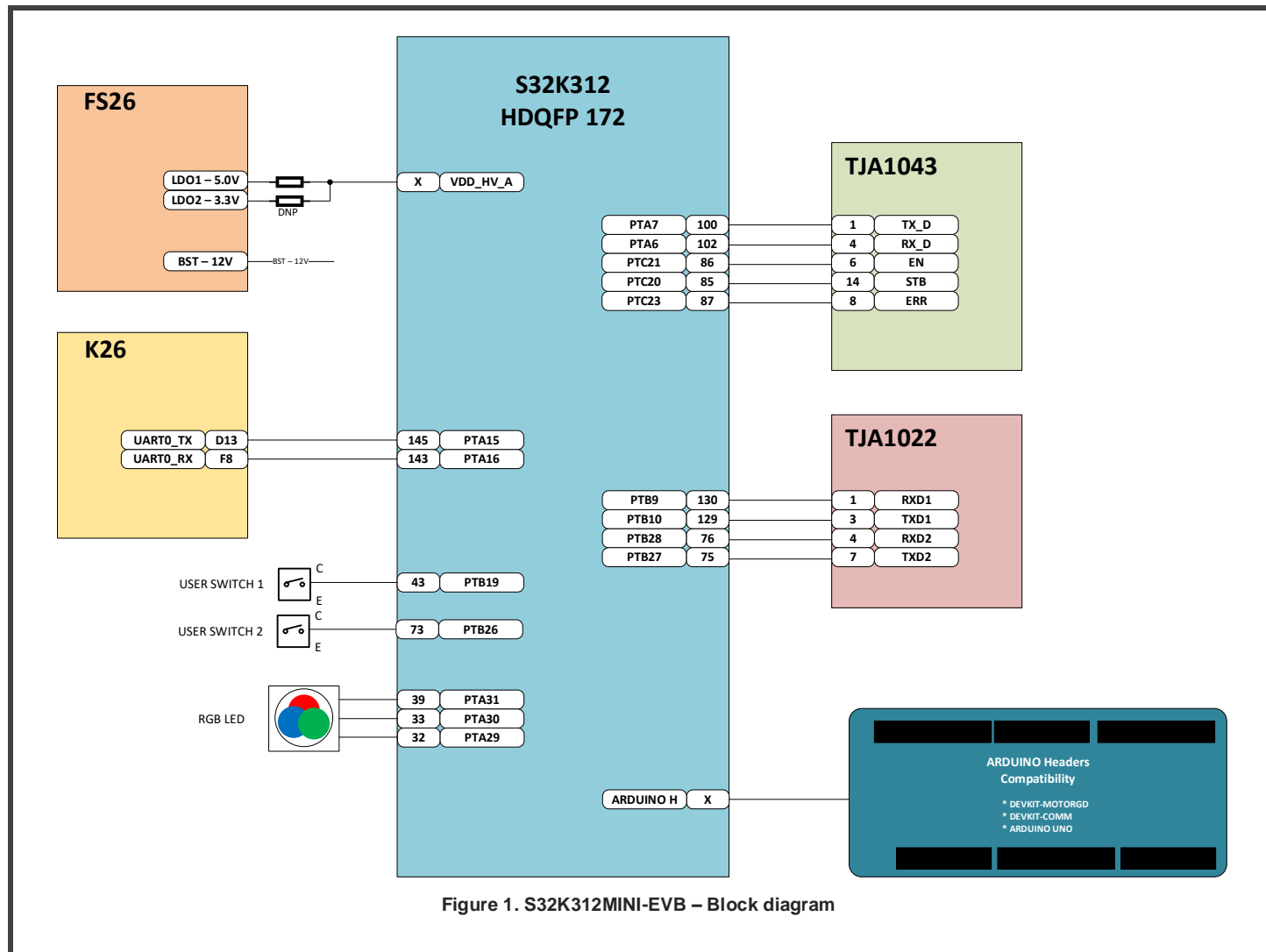

Figure 1. S32K312MINI-EVB – Block diagram

## 4 S32K312MINI-EVB – Features

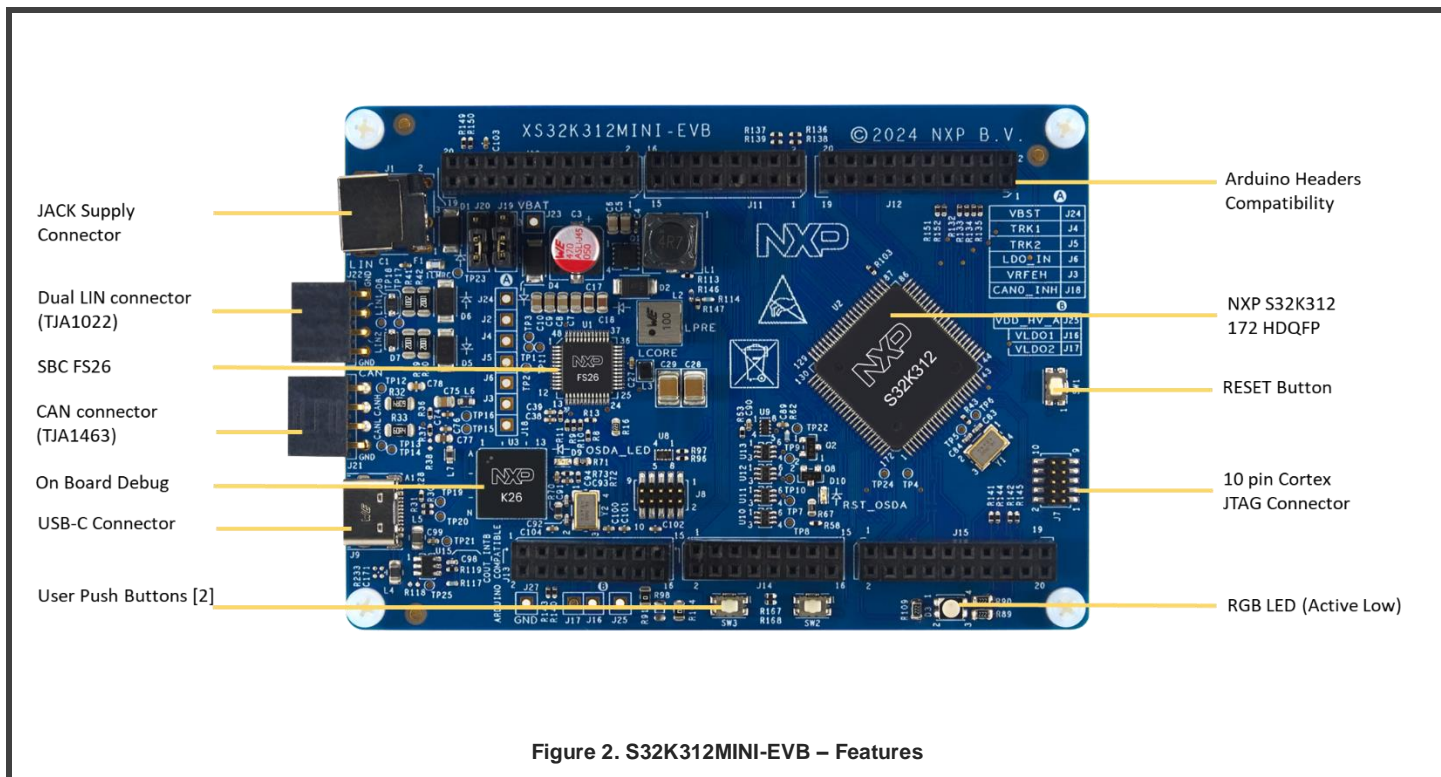

Figure 2. S32K312MINI-EVB – Features

### IMPORTANT

- Before supplying the S32K312MINI-EVB board is used or power is applied, please fully read this user manual. An incorrect configuration in the board may cause an irreparable damage to the component, MCU or entire board.

## 5 S32K312MINI-EVB – Default Configuration

Table 1. S32K312MINI-EVB - Default Configuration

Interface	S32K312MINI-EVB	Reference / Signal	Default Configuration	Description/Comment
MCU	●	U2	S32K312 MCU	ASIL B single ARM M7 core 120 MHz and 2MB General purpose MCU. Optimized for Real-time with zero wait I/D-TCM.
Supply Jumpers	●	J20	1 – 2	Select the supply input. More information described in Chapter <a href="#">S32K312MINI-EVB – Supply options</a>
	●	J19	1 – 2	
MCU Power Supply	●	VDD_HV_A	+5.0V / +3.3V	The actual voltage connected to this reference signal is +5.0V whose is generated by the FS26 LDO1. Is the main I/O and analog supply voltage for the S32K312 MCU. The +3.3V is disconnected as default. This voltage is generated by FS26 LDO2.
	●	V11	+1.1V	Core logic supply internally generated
JTAG	●	J7	Enable	The JTAG interface of the S32K312 MCU is connected through a 10 pin 1.27mm header
Dual LIN Interface	●	J22	J22-2 LIN1	Configured by FXIO D28 and D29
			J22-3 LIN2	Configured by LPUART5
CAN Interface	●	J21	J21-2 – CANH	The S32K312 is connected to a TJA1463 CAN PHY through CAN0 RX and TX signals
			J21-3 – CANL	
On Board Debug	●	PTA15 – LPUART6_RX	Enable	The Onboard Debug interface is connected through JTAG pins and LPUART6 interface
		PTA16 – LPUART6_TX	Enable	
User RGB LED	●	D3	PTA29	Red [Active Low]
			PTA30	Green [Active Low]
			PTA31	Blue [Active Low]
User Push Button	●	SW2	PTB19	For general purpose
	●	SW3	PTB26	For general purpose
ARDUINO Headers	●	-	-	This board incorporates compatibility with ARDUINO UNO, DEVKIT-MOTORGD and DEVKIT-COMM boards. Consult the schematic and Arduino chapter for more details in the routed pins.

## 6 S32K312MINI-EVB – Power Supply

### 6.1 S32K312MINI-EVB – Supply options

The S32K312MINI-EVB is a fast prototyping board based on the S32K312EVB-Q172 which means that this product was not designed as an end board, so this board includes two ways to be supplied according the application whose are explained in the [Table 2](#)

Table 2. Supply Selector





Jumper Position for J19 & J20	Mode	Max Voltage / Current supported	Description
 <p>3 2 1</p>	Low demand current application	+5V / 400 mA	<p>The first method to provide power is via J9 USB-C connector (this board does not include power delivery) but the current will be limited to 500mA (this to enable for Desktops with USB-A or USB-C connector), so this supplying method is only recommended for low demand current applications. Even in this supplying method CAN or LIN PHY (Is not recommended to use both PHYs at maximum current demand at the same time) can work because the FS26 enable a boost circuit to supply the +12.0V voltage references of the PHYs. The maximum current demand for +12.0V in this supplying method is 170mA due to the boost circuit consumption. To supply the board with the above described methodology, follow the steps described in the <a href="#">Table 5</a>.</p> <p><b>NOTE:</b> This board do not includes power delivery connected to USB-C connector input</p>
 <p>3 2 1</p>	High demand current application	+12V / 2 A	<p>The second method to supply power this board requires plugging in the voltage supply in the jack connector J1 (+12.0V/2A), this option to supply the board is recommended for applications with higher demand current or using the compatible boards. To supply the board with the above described methodology, follow the steps described in the <a href="#">Table 5</a></p>

Table 3. Supply connectors

Supply Connector	Reference	Description
	J1	<p><b>2.1mm DI 5.5mm DE Barrel Connector</b> This connector should be used to connect the supplied wall-plug mains adapter. Note – if a replacement or alternative adapter is used, care must be taken to ensure the 2.1mm plug uses the correct polarization as shown</p>
	J9	<p><b>CONN RCP USB2.0 TYP C 24P SMD</b> (USB TYPE-C) USB 2.0 Receptacle Connector 24 (16+8 Dummy) Position Surface Mount, Right Angle; Through Hole</p>

## 6.2 S32K312MINI-EVB – Start-up sequence

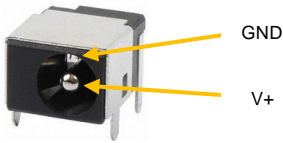
Table 4. Supply board method (Low Current)



Step sequence	Description	Graphical Description
A)	Ensure that the jumpers J19 and J20 are placed in the position 1 – 2 in order to power supply via the USB-C connector (J9).	
B)	Plug in the USB-C cable to the J9 connector	

Table 5. Supply board method (High Current)

Step sequence	Description	Graphical Description
A)	Ensure that the jumpers J19 and J20 are placed in the position 2 – 3 in order to power supply via JACK connector(J1).	
B)	Plug in the 12V power supply through J1 connector.	

## 6.3 S32K312MINI-EVB – Voltage references

This board has 2 possible options to supply power to the board, the FS26 manage the input voltage to supply the different voltage domains in the layout. The PMIC can have different voltage values for the two different input voltage values.

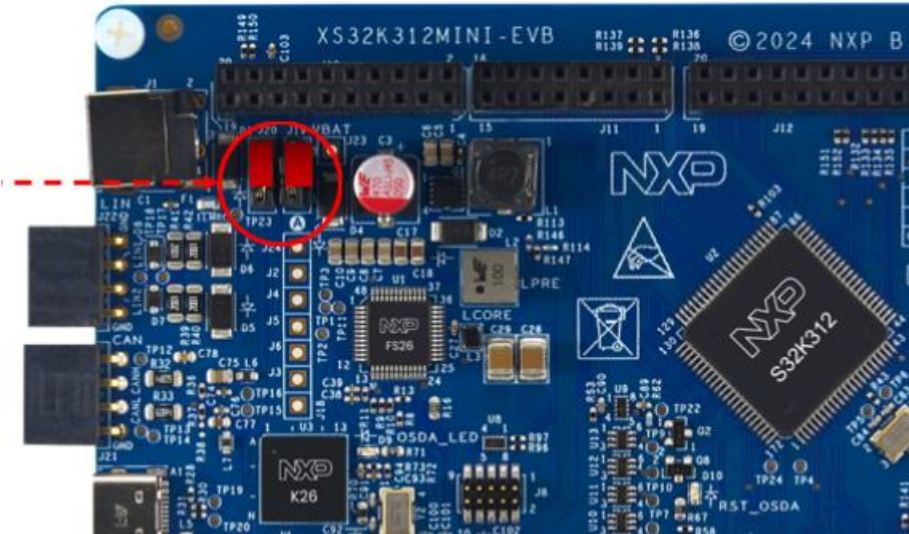
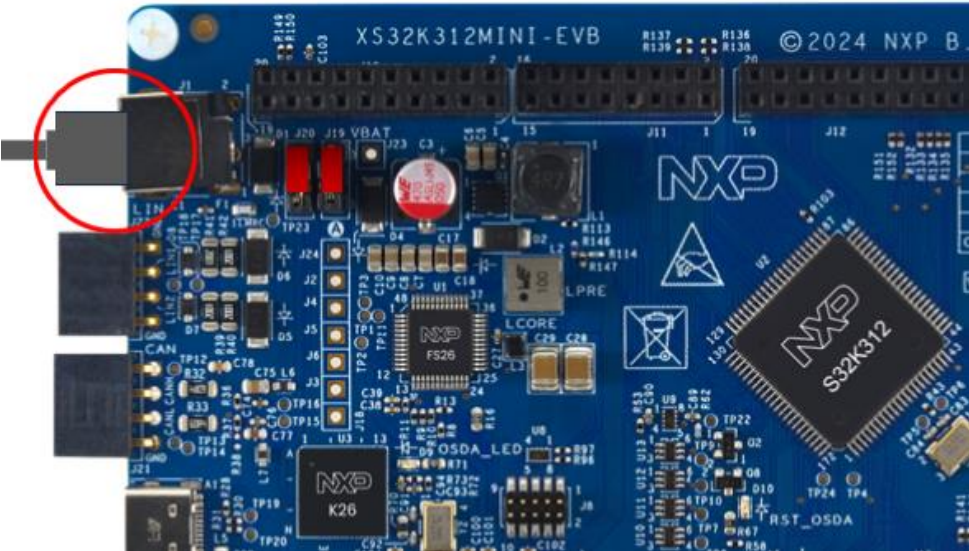
When the board is supplied through the USB-C connector the FS26 uses the internal boost to increase the voltage from +5.0V to +12.0V. This voltage ranges are required for the LIN and CAN PHYs to have a correct functionality even when using 5 volts as main power supply for the board (via J9). In this mode, the maximum power consumption the board can manage is 150mA at the output of the boost.

For the case where the boost is not necessary because the board is being supplied via J1 connector for more current demand applications, the boost of the FS26 will do a bypass of the voltage from the power source. In this case the boost will be disabled automatically and the +12.0V voltage references of the board will be supplied from the JACK connector.

The FS26 integrates 2 LDOs. These LDOs are programmed to generate +5.0V on LDO1 and +3.3V on LDO2 output. This output voltages are used to supply the MCU and the peripherals connected to it.

For voltage measurement, this board includes some Through Hole Pads to measure the main voltage references as VBAT, VBST, P5V0 (FS26 LDO1), P3V3 (FS26 LDO2), VDD\_HV\_A and GND (Table 6).

Table 6. Through Hole Pads for measure voltages

Image	THP reference	Signal	Expected Voltage	Description
	J16	P5V0	+5.0V	Output voltage from LDO1 of the FS26, the current is limited to 400 mA and supplies
	J17	P3V3	+3.3V	Output voltage from LDO2 of the FS26, the current is limited to 400 mA
	J23	VBAT	+5.0V	In case the Low Current option were selected by jumpers J19 & J20
			+12.0V	In case the High Current option were selected by jumpers J19 & J20
	J24	VBST	+12.0V	Output voltage from FS26 Boost. This Reference is not used when the HIGH Current option is selected from supply jumpers
	J25	VDD_HV_A	+5.0V / +3.3V	This is the voltage domain that supplies the S32K312 MCU. This voltage can vary according to the resistor populated but some peripherals or interfaces as RGB LED and CAN won't support the +3.3V supply
	J27	GND	-	Ground reference of the board

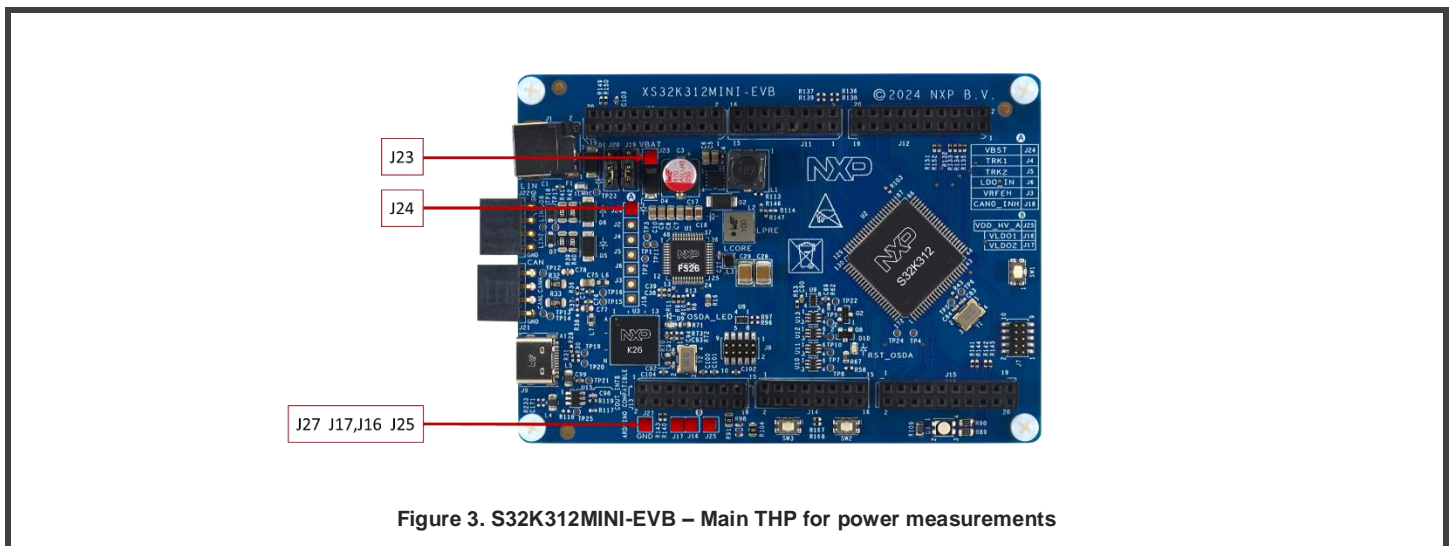

Figure 3. S32K312MINI-EVB – Main THP for power measurements

## 6.3.1 S32K312MINI-EVB – Main Supply

As was mention above, this board includes two ways to be supplied in order to enable both high and low demand current.

For the case where a low demand current is selected using the required configuration in jumpers J19 & J20, the voltage is supplied from the USB-C connector J9 and pass through a current limiting circuit (MIC2005-0.5YM6) in order to avoid demand more current to the USB port of the Desktop where is connected, this is showed in the [Figure 4](#) b)

Figure 4 .

In order to understand it better the brown lines in the image b, the reference named P5V0\_BAT (brown color signal) became to P5V0\_OSDA\_VBAT signal (deep blue color signal).

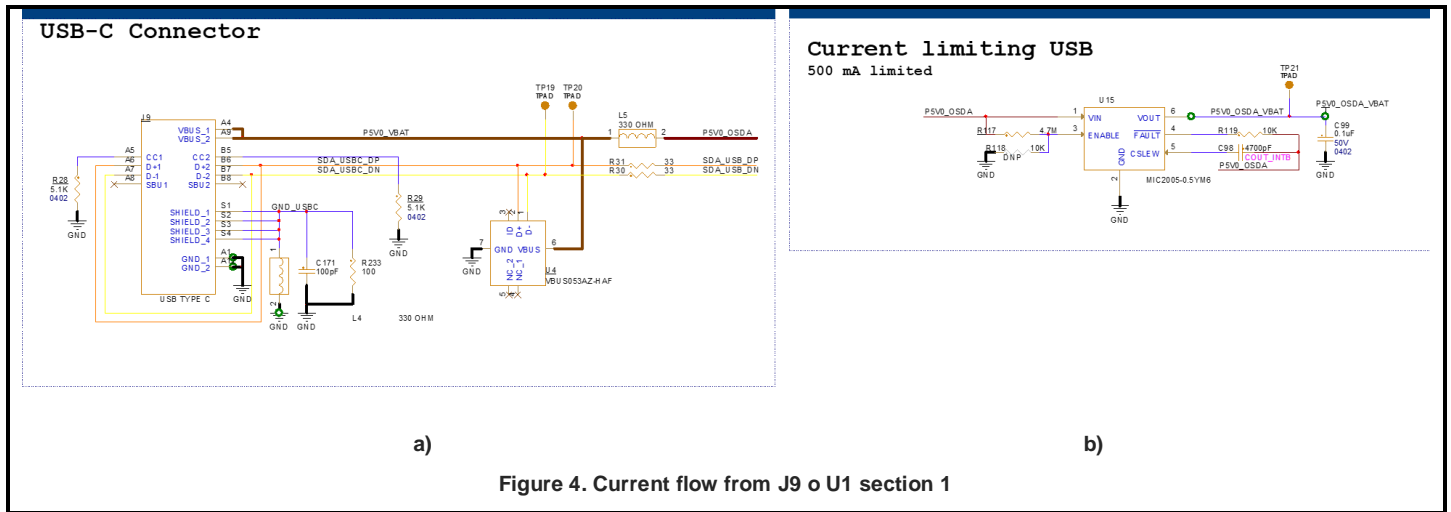

Figure 4. Current flow from J9 o U1 section 1

Then using the J20 in position 1-2, the voltage reference whose name is VBAT is being connected to FS26 boost circuitry, increasing the voltage from +5.0V to +12.0V, having that value, the voltage reference is named VBST but as works in any boost circuit, the current consumption increase to generate the required voltage. The above is showed in the [Figure 5](#).

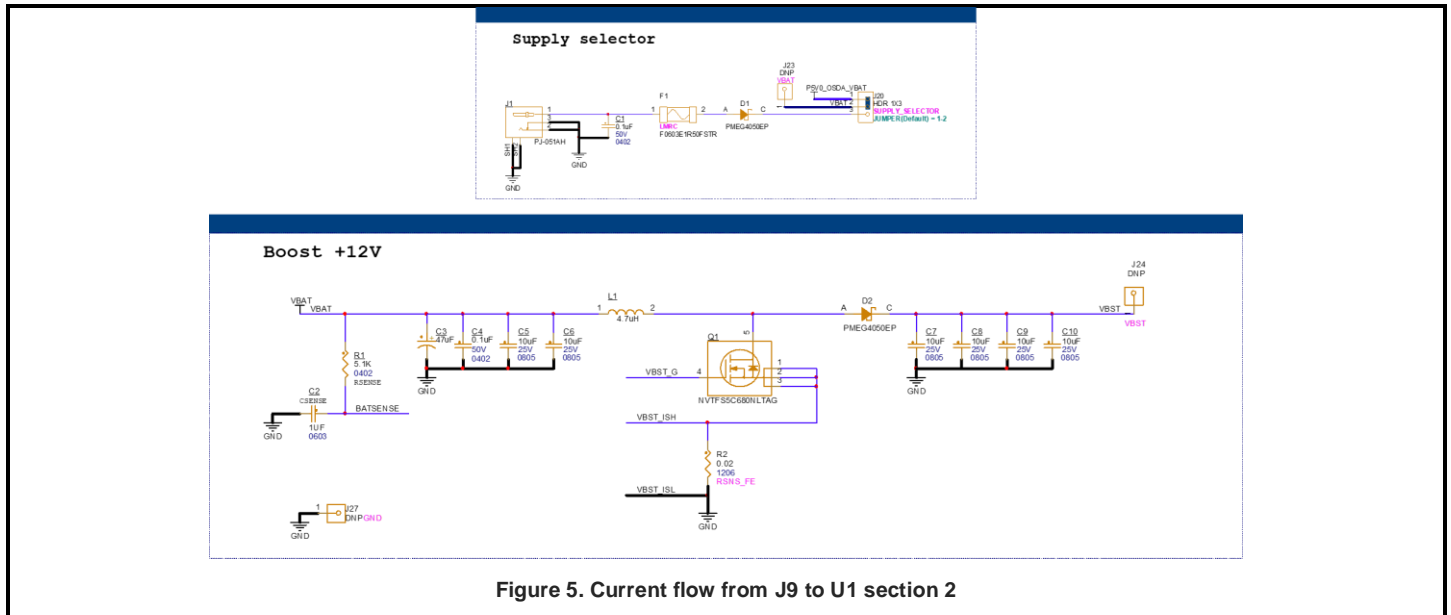

Figure 5. Current flow from J9 to U1 section 2



### 6.3.4 S32K312MINI-EVB – V11

Although this MCU does not require an external power supply in the pins of V11 it is mandatory to connect all the pins of V11 together but in each one of them connect a decoupling capacitor for the purpose of having integrity in the core voltage that is generated internally from VDD\_HV\_A voltage reference as is shown in [Figure 7](#).

### 6.3.5 S32K312MINI-EVB – V25

The V25 pin is another pin whose voltage is generated internally by the VDD\_HV\_A but this supplies the flash memory and (via double bond) the clock modules, nevertheless a decoupling capacitor near of the pin is mandatory for this voltage reference. See the [Figure 7](#).

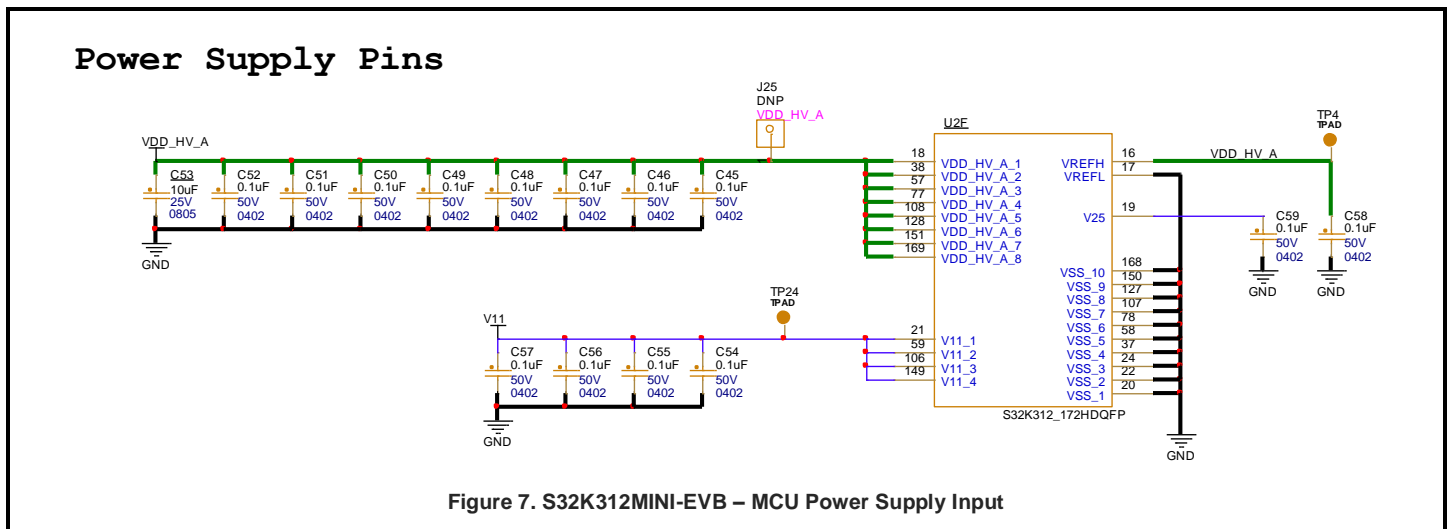

Figure 7. S32K312MINI-EVB – MCU Power Supply Input

Table 7. Decoupling and Bulk capacitors used in S32K312MINI-EVB

Capacitor	Characteristic	Value
Decoupling Capacitor	X7R / X8R Ceramic	100nf
Bulk Capacitor	X7R / X8R Ceramic	10uF

## 7 S32K312MINI-EVB – Programming and Debug Interface

### 7.1 S32K312MINI-EVB – RESET Switch and LED indicator

The RESET switch [SW1] provides for manual application of the RESET input signal. The S32K3 MCU will drive the RESET signal to reset the board peripherals. The RESET LED indicator [D10] will be ON for the duration of the RESET signal. This operation indicates the S32K312 MCU is in the Reset state.

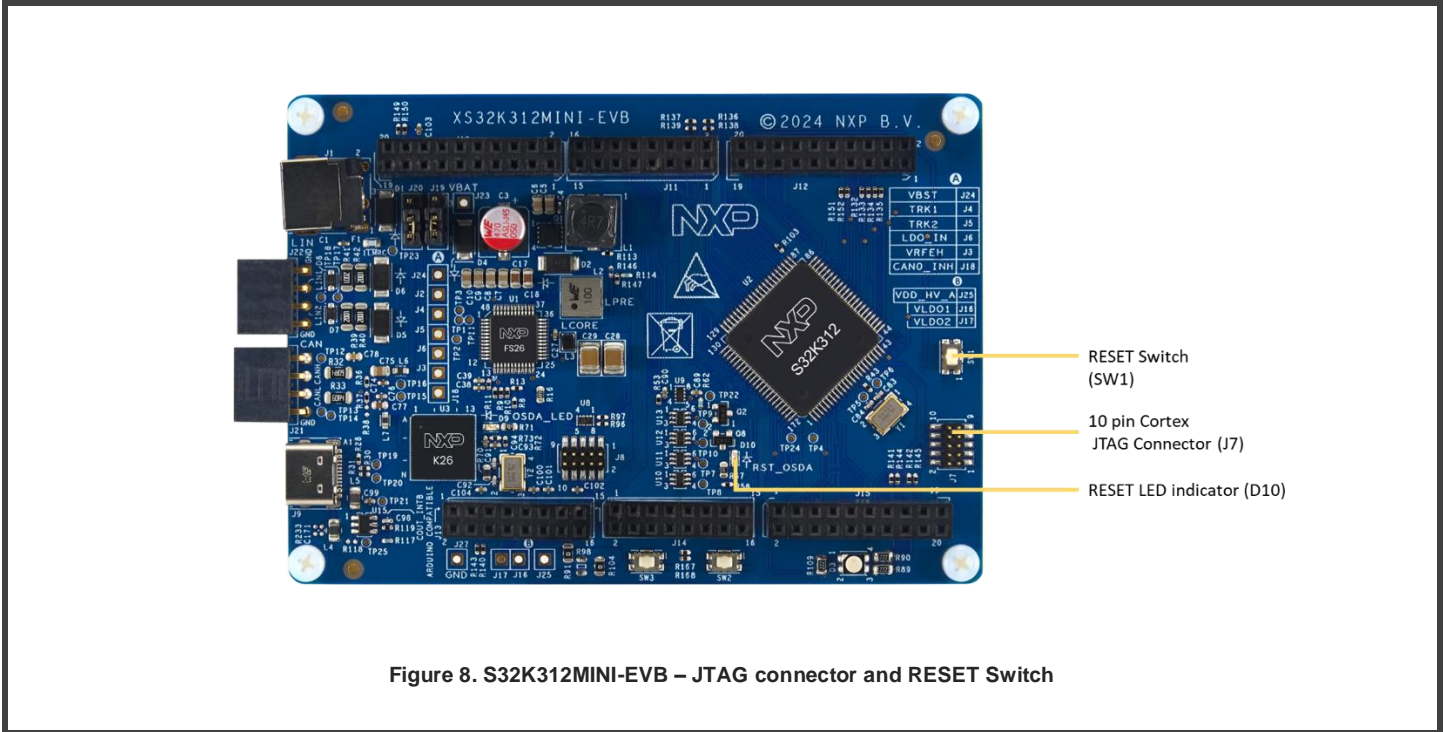

Figure 8. S32K312MINI-EVB – JTAG connector and RESET Switch

## 7.2 S32K312MINI-EVB – JTAG

The S32K312MINI-EVB incorporates JTAG connectors to program the MCU using a PE Multilink Universal FX Debug Probe which allows the user control the target’s execution, read/write registers and memory values, debug code on the processor, and program internal or external FLASH memory devices. In summary It bridges serial and debug communications between an USB host and an embedded target processor.

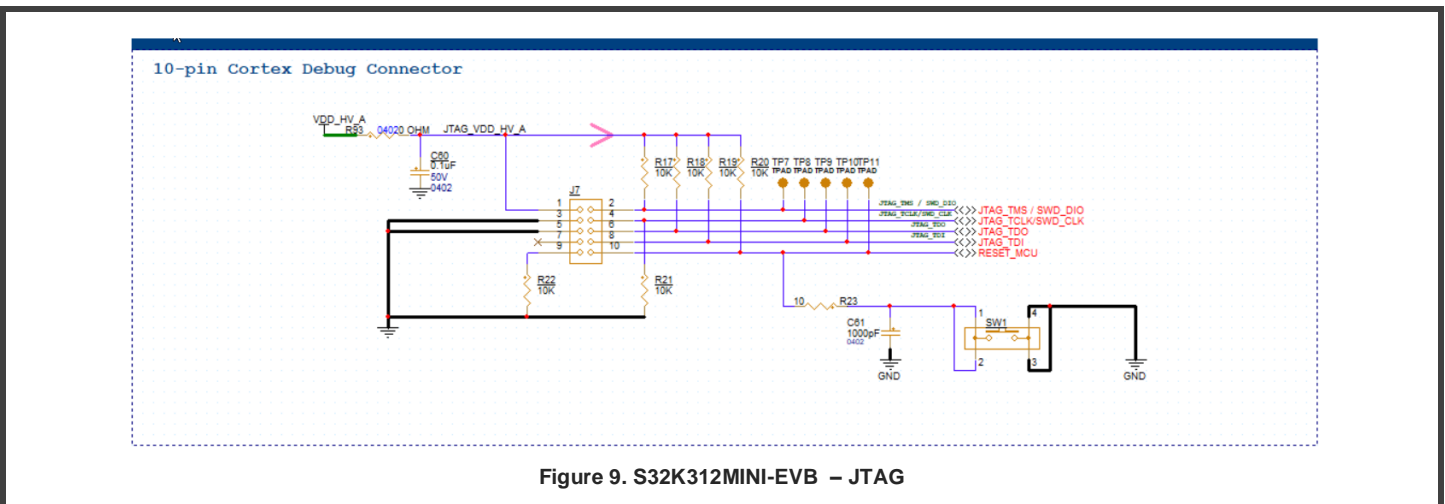
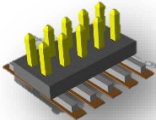

Figure 9. S32K312MINI-EVB – JTAG

Table 8. Programming and Debug Connectors

Connector	Reference/Component	Description
10-Pin Cortex Debug 	<b>J7</b>	The Cortex Debug Connector provides support for Serial Wire and JTAG interface modes in a very small, and low cost 10-pin (0.05") connector. This new connector style provides access to all SWD, SWV, and JTAG signals available on a Cortex-M device. A 10-pin header (Samtec FTSH-105-01) is specified with these dimensions: 0.25" x 0.188" (6.35 mm x 4.78 mm).

## 7.3 S32K312MINI-EVB – On board Debugger

The board incorporates an On-Board Debugger embedded well as JTAG connectors. It bridges serial and debug communications between a USB host and an embedded target processor (in this case the K26).

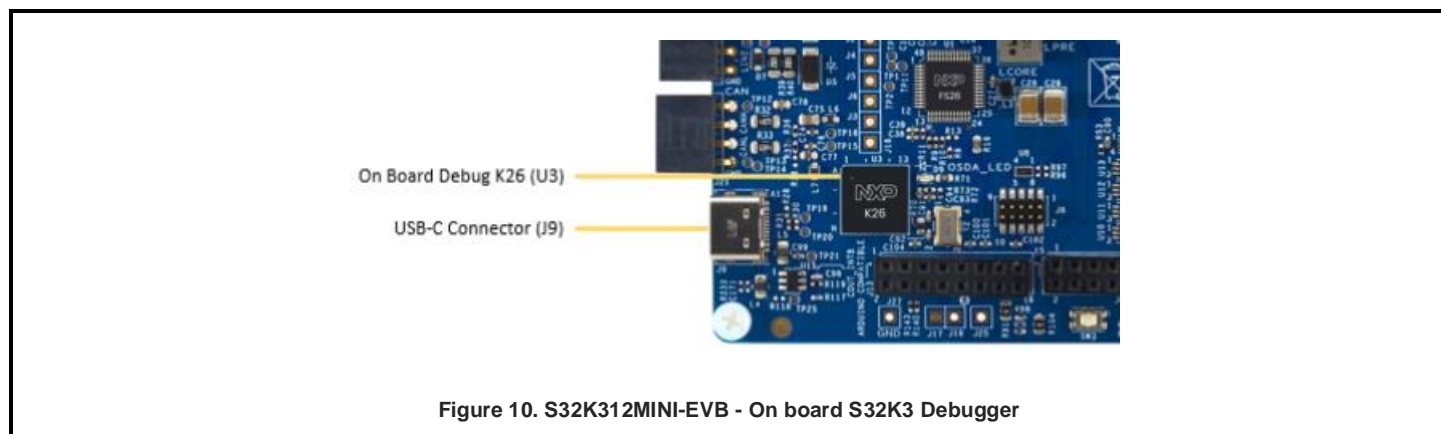

## 8 S32K312MINI-EVB – LIN Interface

The S32K312MINI-EVB incorporates two LIN interfaces connected the S32K312 MCU. Using an NXP LIN transceivers the TJA1022 , supporting master mode. The output from the LIN transceivers is connected to J22. The pinout of these headers is shown in [Table 9](#)

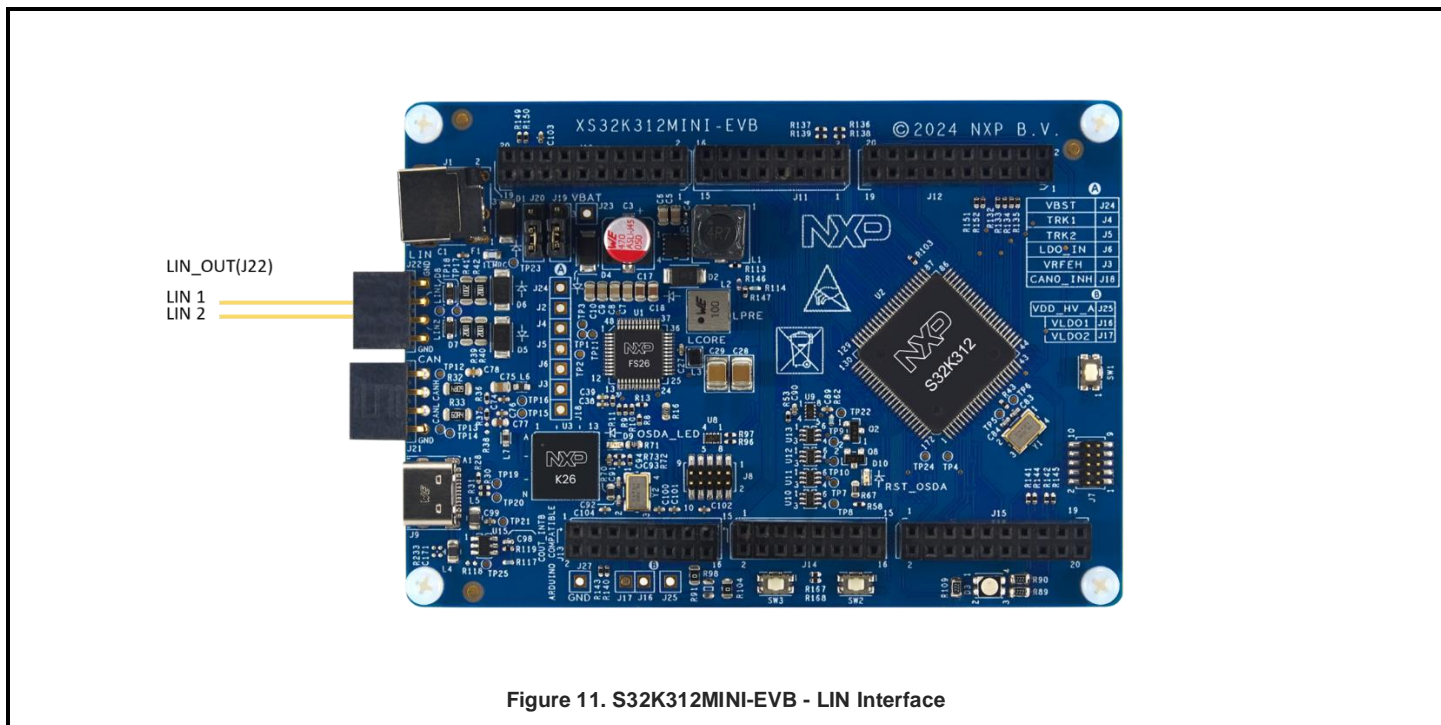

Figure 11. S32K312MINI-EVB - LIN Interface

Table 9. S32K312MINI-EVB - LIN Output connection

Connector	Reference	Pin Number	Signal
	J22	1	GND
		2	LIN1
		3	LIN2
		4	GND

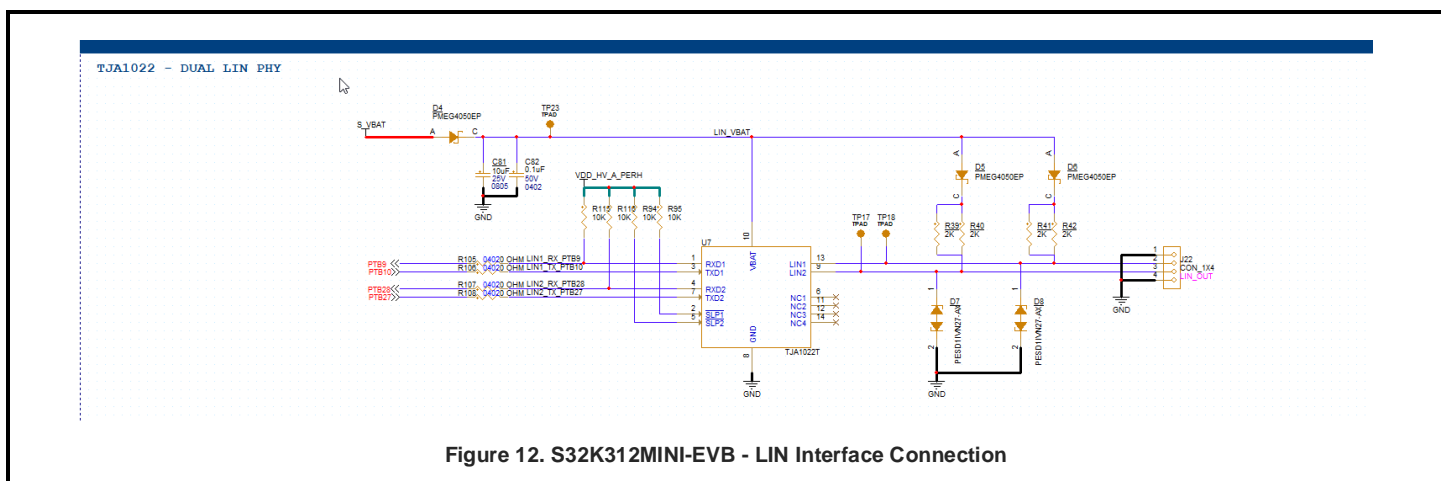

Figure 12. S32K312MINI-EVB - LIN Interface Connection

One of the great features of this board is the capability to use LIN interface with or without 12 volts supply using the boost from the FS26, so in this case the 12 volts supplies the LIN PHY TJA1022 pin 10 (VBAT) and the LIN out signals. Is recommended to don't use the LIN and CAN PHY at the same time meanwhile the board is supplied by Low Current methodology (Using USB connector J9)

Table 10. LIN signal assignment

LIN Interface	Signal Name	MCU Port	Comments
TJA1022	LIN1_RX	PTB9	FXIO D28
	LIN1_TX	PTB10	FXIO D27
	LIN2_RX	PTB28	LPUART5_RX
	LIN2_TX	PTB27	LPUART5_TX

## 9 S32K312MINI-EVB – CAN Interface

This board uses a NXP CAN transceiver TJA1043. The output from the CAN transceiver is connected to J21. See details in the [Table 11](#).

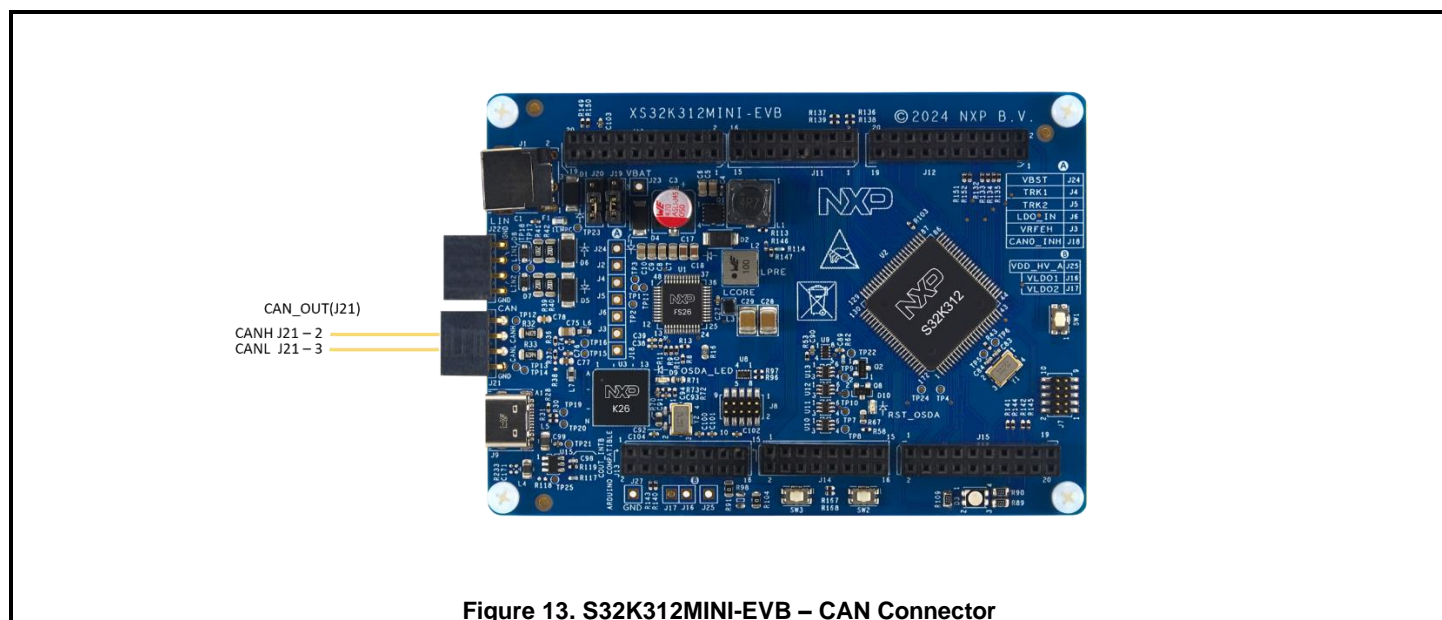



Figure 13. S32K312MINI-EVB – CAN Connector

Table 11. CAN Interface - Connector

Connector	Reference	Circuit/Interface	Pin Number	Signal/Connection
	J21	CAN0	1	NC
			2	CANH
			3	CANL
			4	GND

This CAN PHY can be supplied both high current demand method and low current demand method but is recommended to only use this PHY in case the low current demand method under use. This differential pair is routed at 100 ohms.

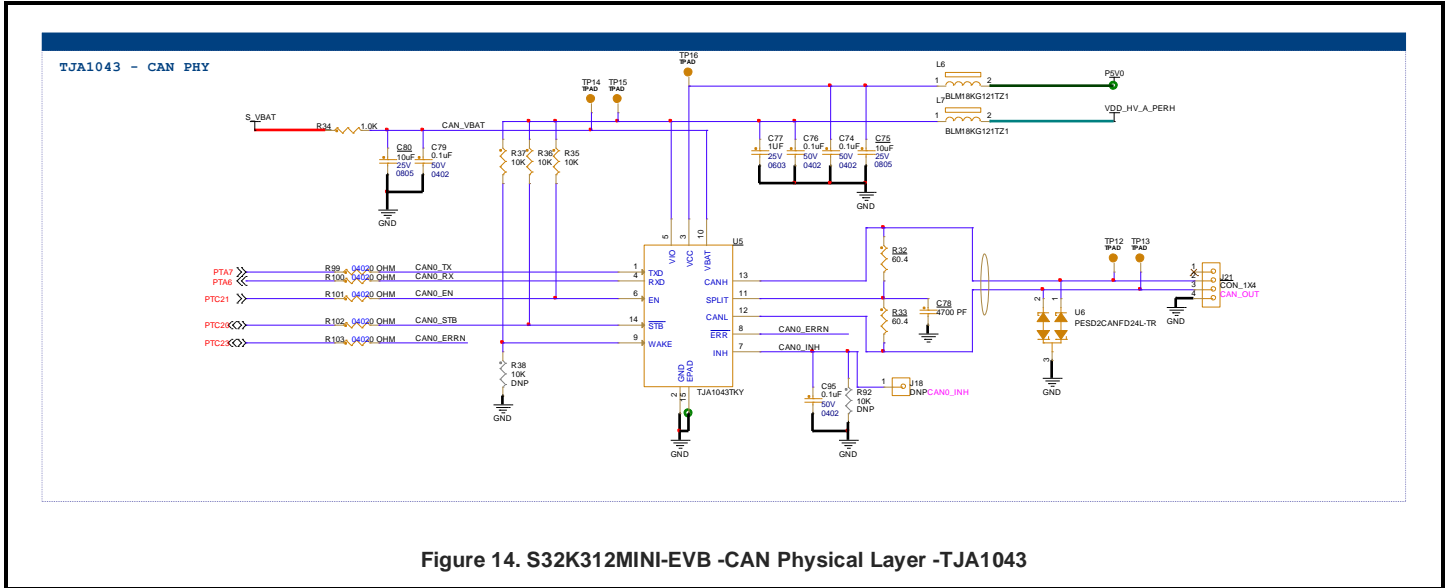

Figure 14. S32K312MINI-EVB -CAN Physical Layer -TJA1043

The S32K312 MCU has a great feature that includes the FLEXCAN connected to the PHY in order to make it easier to communicate the board to another node.

Table 12. CAN Interface - MCU connections

LIN Interface	Signal Name	MCU Port	Comments
TJA1043	CAN0_RX	PTA6	[CAN0_RX Module] is routed to CAN Phy0
	CAN0_TX	PTA7	[CAN0_TX Module] is routed to CAN Phy0
	CAN0_ERRN	PTC23	PTC23 is routed to CAN Phy0 as CAN0_ERRN
	CAN0_EN	PTC21	PTC21 is routed to CAN Phy0 as CAN0_EN
	CAN0_STB	PTC20	PTC20 is routed to CAN Phy0 as CAN0_STB

## 10 S32K312MINI-EVB – User Peripherals

### 10.1 S32K312MINI-EVB – RGB LED Indicator

The board includes an active low user RGB LEDs connected to the MCU ports. The USERLEDs are connected as follows:

Table 13. USER LED Indicator

Reference	Signal Name	MCU Port	Comments
D3	RGB_REDLED_PTA29	PTA29	RED LED Active Low
	RGB_GREENLED_PTA30	PTA30	GREEN LED Active Low
	RGB_BLUELED_PTA31	PTA31	BLUE LED Active Low

Warning: In case the board would be supplied by 3.3V reference the LED won't work as expected

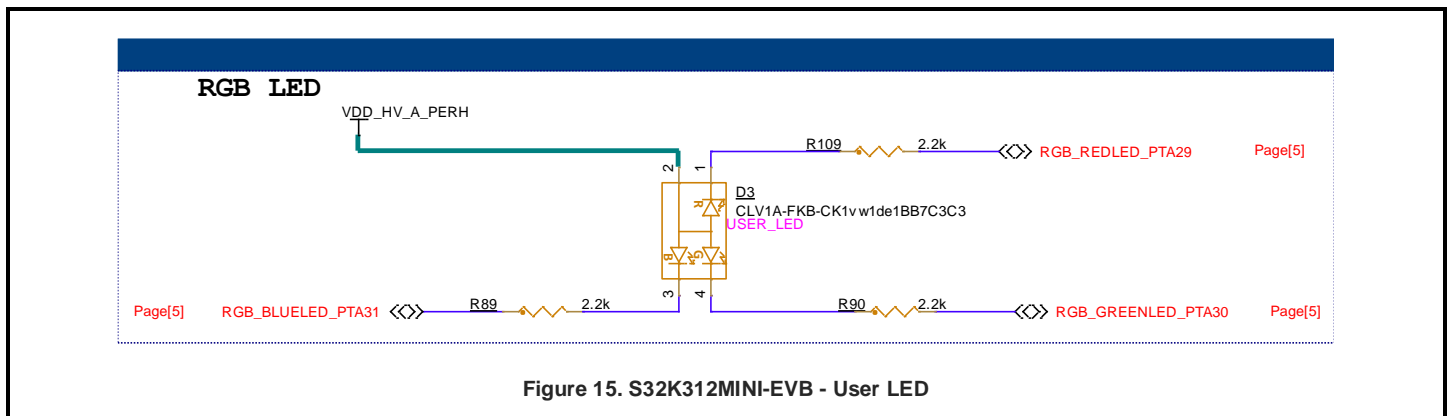

### 10.2 S32K312MINI-EVB – User Pushbuttons

The board integrates 2 push-buttons active low (pulled high), driven to VDD\_HV\_A, the push button SW2 is connected to PTB19 MCU port meanwhile the push-button SW3 is connected to PTB26. The switch is connected as follows:

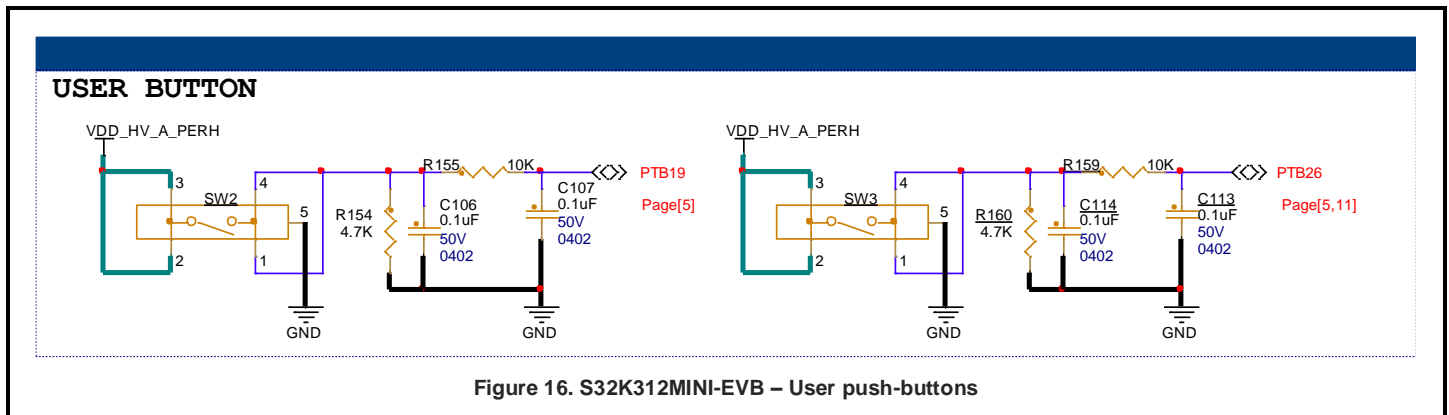

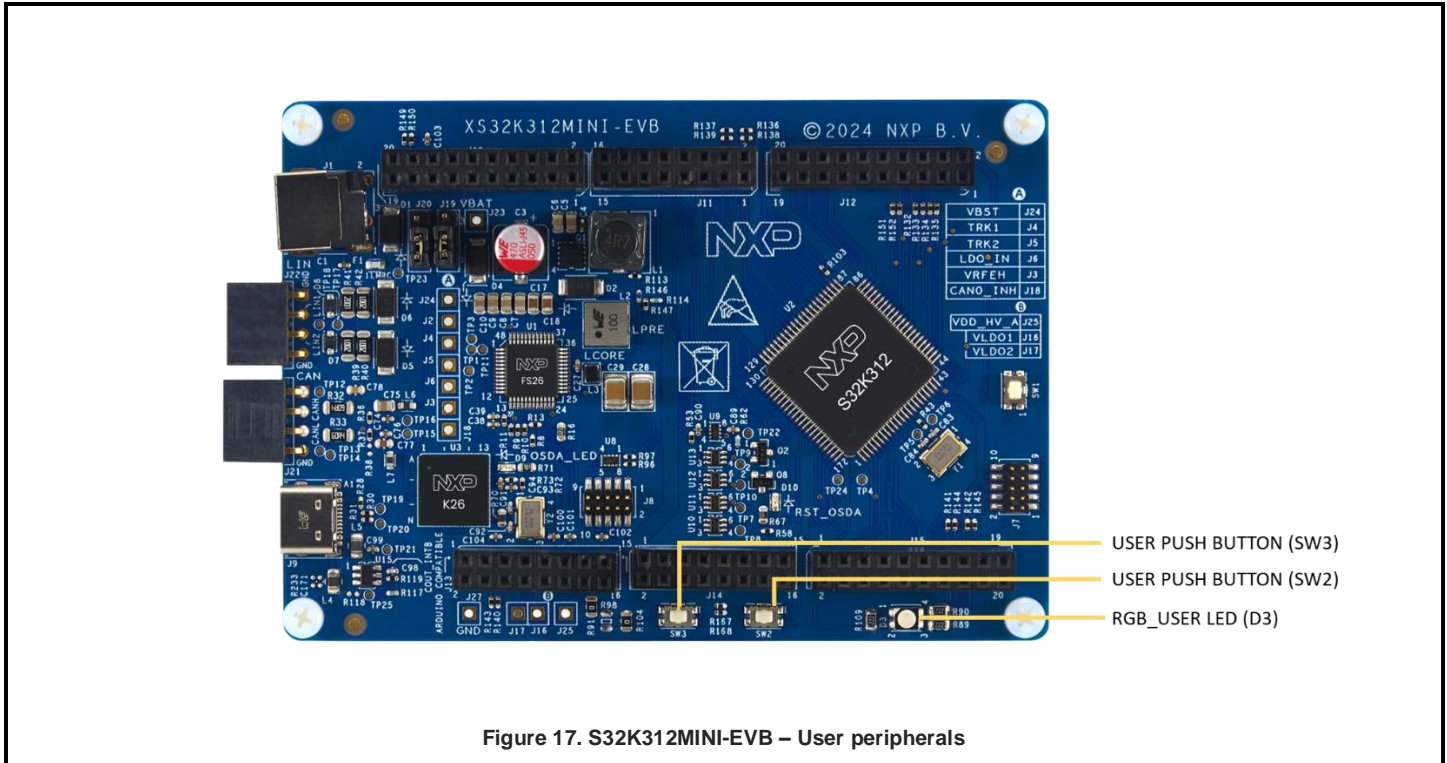

Figure 17. S32K312MINI-EVB – User peripherals

This user push buttons are connected to PTB19 and PTB26 pin in the S32K312MCU, and can be used for debug or application uses.

Table 14. User Push-Buttons

Peripheral	MCU Port	Comments
SW2	PTB19	Active high push-buttons
SW3	PTB26	

## 11 Pinout assignment

Despite the small size of this board and the Arduino pin headers reduction present in the S32K312MINI-EVB compared to S32K312EVB-Q172, this board includes compatibility in the inner connectors with the S32K312EVB-Q172 board, so if you build a project in the MINI board can be escalated to the EVB with almost any modification in the pins (Unless one of the pins whose resistance is in DNP is used)

In order to enable a complete experience when using this board and the NXP shield boards, it was designed so that it is compatible with other NXP boards such as [DEVKIT-MOTORGD](#) (which is a plug-in board/shield for motor control solution) and [DEVKIT-COMM](#) (which is a hardware plug-in adapter board to supports 4 additional CAN and 6 additional LIN/SCI connections) in order to plugin in the board to expand the functionalities (Those boards are not included with the S32K312MINI-EVB).

For more details related to DEVKIT-MOTORGD and DEVKIT-COMM pinout in this board, see [Figure 18](#).

Additionally this board includes the Arduino UNO standard, review [Figure 19](#).

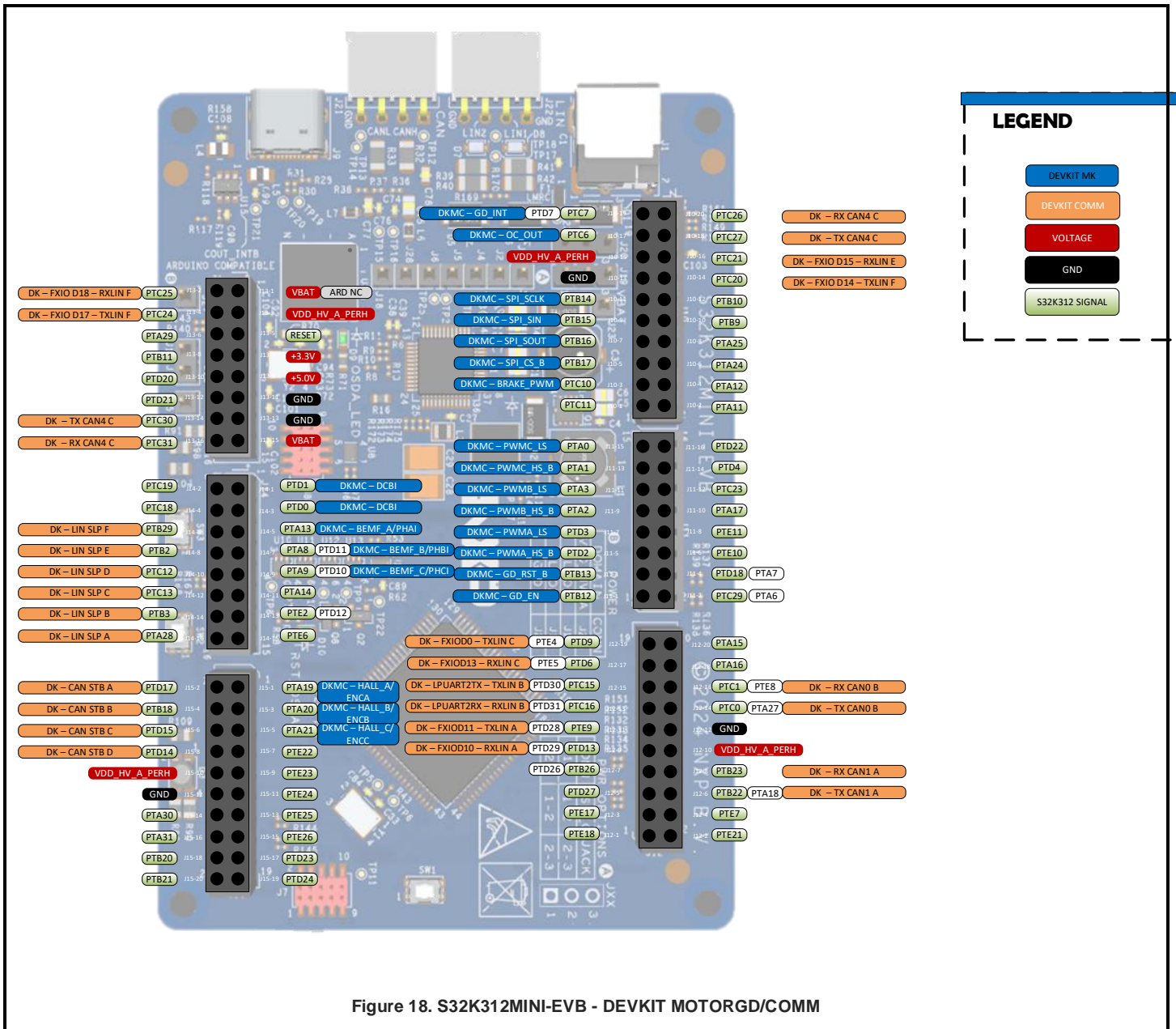

Figure 18. S32K312MINI-EVB - DEVKIT MOTORGD/COMM



## 12 S32K312MINI-EVB – Revision history

Table 15. Revision History

Document Revision	Date	Board Name	Schematic/ Board Number	Schematic/ Revision	Board Revision	Changes	Author
X	10/2024	S32K312MINI-EVB	94288	A	A	Initial version	Luis Manuel Rico Chávez
A	01/2025	S32K312MINI-EVB	94288	B	B	Figures updated with the schematic B version Access to SPI0 at J10 and J14 ARDUINO connector Table 1 updated, supply jumpers updated Figure 2 updated features	Luis Manuel Rico Chávez
A1	01/2025	S32K312MINI-EVB	94288	C	C	Images updated with real photos. The schematic changes were only to match the revision between layout and schematic	Luis Manuel Rico Chávez

## 13 Legal Information

### 13.1 Definitions

**Draft** — A draft status on a document indicates that the content is still under internal review and subject to formal approval, which may result in modifications or additions. NXP Semiconductors does not give any representations or warranties as to the accuracy or completeness of information included in a draft version of a document and shall have no liability for the consequences of use of such information.

### 13.2 Disclaimers

**Limited warranty and liability** — Information in this document is believed to be accurate and reliable. However, NXP Semiconductors does not give any representations or warranties, expressed or implied, as to the accuracy or completeness of such information and shall have no liability for the consequences of use of such information. NXP Semiconductors takes no responsibility for the content in this document if provided by an information source outside of NXP Semiconductors. In no event shall NXP Semiconductors be liable for any indirect, incidental, punitive, special or consequential damages (including - without limitation - lost profits, lost savings, business interruption, costs related to the removal or replacement of any products or rework charges) whether or not such damages are based on tort (including negligence), warranty, breach of contract or any other legal theory. Notwithstanding any damages that customer might incur for any reason whatsoever, NXP Semiconductors' aggregate and cumulative liability towards customer for the products described herein shall be limited in accordance with the Terms and conditions of commercial sale of NXP Semiconductors.

**Right to make changes** — NXP Semiconductors reserves the right to make changes to information published in this document, including without limitation specifications and product descriptions, at any time and without notice. This document supersedes and replaces all information supplied prior to the publication hereof.

**Applications** — Applications that are described herein for any of these products are for illustrative purposes only. NXP Semiconductors makes no representation or warranty that such applications will be suitable for the specified use without further testing or modification. Customers are responsible for the design and operation of their applications and products using NXP Semiconductors products, and NXP Semiconductors accepts no liability for any assistance with applications or customer product design. It is customer's sole responsibility to determine whether the NXP Semiconductors product is suitable and fit for the customer's applications and products planned, as well as for the planned application and use of customer's third-party customer(s). Customers should provide appropriate design and operating safeguards to

minimize the risks associated with their applications and products. NXP Semiconductors does not accept any liability related to any default, damage, costs or problem which is based on any weakness or default in the customer's applications or products, or the application or use by customer's third-party customer(s). Customer is responsible for doing all necessary testing for the customer's applications and products using NXP Semiconductors products in order to avoid a default of the applications and the products or of the application or use by customer's third-party customer(s). NXP does not accept any liability in this respect.

**Suitability for use in automotive applications** — This NXP Semiconductors product has been qualified for use in automotive applications. Unless otherwise agreed in writing, the product is not designed, authorized or warranted to be suitable for use in life support, life-critical or safety-critical systems or equipment, nor in applications where failure or malfunction of an NXP Semiconductors product can reasonably be expected to result in personal injury, death or severe property or environmental damage. NXP Semiconductors and its suppliers accept no liability for inclusion and/or use of NXP Semiconductors products in such equipment or applications and therefore such inclusion and/or use is at the customer's own risk.

**Export control** — This document as well as the item(s) described herein may be subject to export control regulations. Export might require a prior authorization from competent authorities.

**Translations** — A non-English (translated) version of a document is for reference only. The English version shall prevail in case of any discrepancy between the translated and English versions.

**Security** — While NXP Semiconductors has implemented advanced security features, all products may be subject to unidentified vulnerabilities. Customers are responsible for the design and operation of their applications and products to reduce the effect of these vulnerabilities on customer's applications and products, and NXP Semiconductors accepts no liability for any vulnerability that is discovered. Customers should implement appropriate design and operating safeguards to minimize the risks associated with their applications and products.

### 13.3 Trademarks

Notice: All referenced brands, product names, service names and trademarks are the property of their respective owners.

**NXP** — wordmark and logo are trademarks of NXP B.V.

## X-ON Electronics

Largest Supplier of Electrical and Electronic Components

*Click to view similar products for [Development Boards & Kits - ARM category](#):*

*Click to view products by [NXP manufacturer](#):*

Other Similar products are found below :

[POLYPOD-BGA324](#) [POLYPOD-TQ144](#) [POLYPOD-TQ176](#) [2621](#) [5786](#) [STM3240G-USB/NMF](#) [OM13090UL](#) [ZDSD-Pinboard](#) [Ra-08H-Kit](#)  
[Ai-WB2-13-Kit](#) [Ra-08-Kit](#) [FT8132Q-3HALL-FOC+EMF](#) [APM32F072VBT6](#) [HLK-V20-SUIT](#) [JLC-DIG01](#) [LKS32MC082K8Q8-K](#) [RP2040-](#)  
[Zero](#) [MQTT ANYWHERE KIT - SIM868](#) [W5500-EVB-PICO](#) [MQTT ANYWHERE KIT - SARA-R410M](#) [OLIMEXINO-GD32](#) [M815NEVB](#)  
[M326LZBA](#) [MKSDTestBoard-D](#) [MKIDNV2911](#) [EV72Y42A](#) [RCQ5-433-EV](#) [2510](#) [DEMORADARMCU7TOBO1](#)  
[EVALXMC4800PSOC6M5TOBO1](#) [MIKROE-5193](#) [MIKROE-5427](#) [3780](#) [3056](#) [RCQ5-868-EV](#) [S32K388EVB-Q289](#) [I-COM HPC Ampere](#)  
[Altra DEV Kit-128](#) [I-COM HPC Ampere Altra DEV Kit-96](#) [I-COM HPC Ampere Altra DEV Kit-32](#) [ABX00137](#) [RTK7EKA2L2S00001BJ](#) [I-](#)  
[COM HPC Ampere Altra DEV Kit-64](#) [READY FOR AVR BOARD](#) [READY FOR PIC \(DIP28\)](#) [AVRPLC16 V6 PLC SYSTEM](#) [MIKROLAB](#)  
[FOR PIC L](#) [MINI-M4 FOR STELLARIS](#) [1410](#) [LETS MAKE PROJECT PROGRAM. RELAY PIC](#) [YSDKS128E10](#)