



ELECTRONICS, INC.
 44 FARRAND STREET
 BLOOMFIELD, NJ 07003
 (973) 748-5089
<http://www.nteinc.com>

NTE16007 Silicon NPN Transistor General Purpose for Medium Power Applications

Description:

The NTE16007 is a silicon NPN diffused-junction power transistor in a TO8 type package intended for a wide variety of applications in industrial and military equipment. This device is particularly useful in power-switching circuits such as in DC-to-DC converters, inverters, choppers, solenoid and relay controls; and as class A and class B push-pull audio and servo amplifiers.

Absolute Maximum Ratings:

Collector-to -Emitter Voltage, V_{CEO}	55V
Collector-to-Base Voltage, V_{CBO}	100V
Emitter-to-Base Voltage, V_{EBO}	12V
Continuous Collector Current, I_C	3A
Total Power Dissipation, P_T	
$T_A = +25^\circ C$	25W
Derate Linearly Above $+25^\circ C$	0.010W/ $^\circ C$
$T_C = +25^\circ C$	14.1W
Derate Linearly Above $+25^\circ C$	0.143W/ $^\circ C$
Operating Temperature Range, T_{opr}	-65 to $+200^\circ C$
Storage Temperature Range, T_{stg}	-65 to $+200^\circ C$

Electrical Characteristics:

Parameter	Symbol	Test Conditions	Min	Typ	Max	Unit
OFF Characteristics						
Collector-Emitter Breakdown Voltage	$V_{(BR)CEO}$	$I_C = 100mA$	55	-	-	V
Collector-Base Breakdown Voltage	$V_{(BR)CBO}$	$I_C = 100\mu A$	100	-	-	V
Collector-Emitter Breakdown Voltage	$V_{(BR)CEX}$	$V_{EB} = 1.5V, I_C = 0.25mA$	100	-	-	V
Collector-Base Cutoff Current	I_{CBO}	$V_{CB} = 50V$	-	-	15	μA
Emitter-Base Cutoff Current	I_{EBO}	$V_{EB} = 12V$	-	-	15	μA
ON Characteristics (Note 1)						
Forward-Current Transfer Ratio	h_{FE}	$V_{CE} = 4V, I_C = 750mA$	35	-	100	
Collector-Emitter Saturation Voltage	$V_{CE(sat)}$	$I_C = 750mA, I_B = 40mA$	-	-	0.75	V

Note 1. Pulse Test: Pulse Width = 300 μs , Duty Cycle = 2.0%.

Electrical Characteristics (Con't):

Parameter	Symbol	Test Conditions	Min	Typ	Max	Unit
Dynamic Characteristics						
Forward Current Transfer Ratio	f_{hfb}	$V_{CB} = 28V, I_C = 5mA$	600	-	-	kHz
Output Capacitance	C_{obo}	$V_{CB} = 10V, I_E = 0, f = 100kHz \text{ to } 1MHz$	-	-	400	pF
Switching Characteristics						
Turn-On Time	$t_{on} + t_{off}$	$V_{CC} = 12V, R_C = 15.9\Omega, I_{B0} = I_{B2} = 35mA, I_{B1} = 65mA$	-	-	25	μs

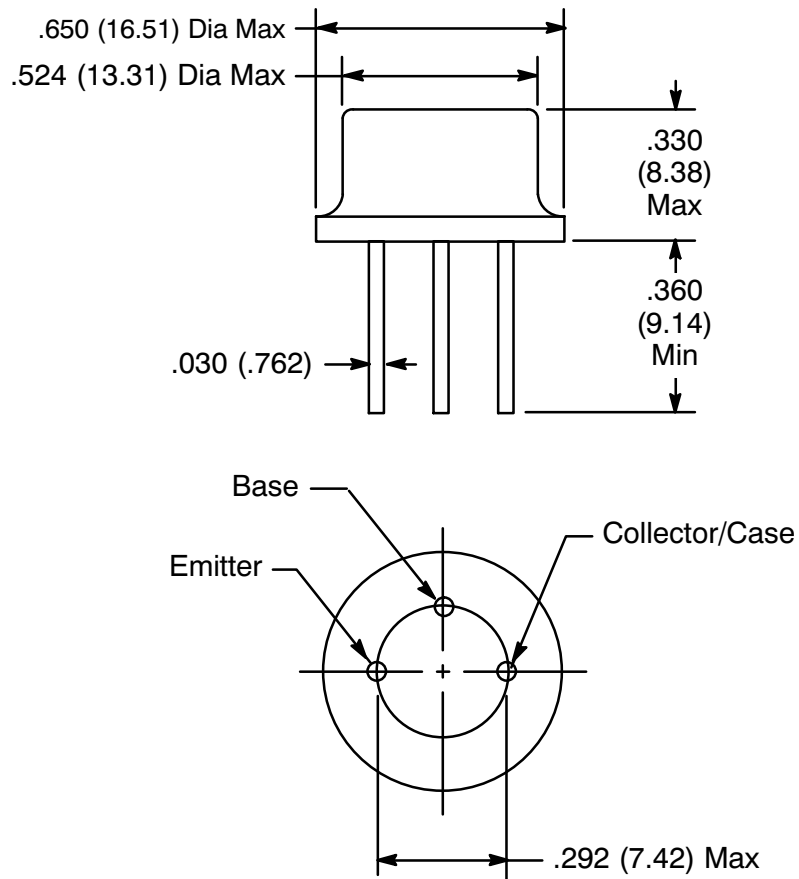

X-ON Electronics

Largest Supplier of Electrical and Electronic Components

Click to view similar products for [Bipolar Transistors - BJT category](#):

Click to view products by [NTE manufacturer](#):

Other Similar products are found below :

[619691C](#) [MCH4017-TL-H](#) [MJ15024/WS](#) [MJ15025/WS](#) [BC546/116](#) [BC556/FSC](#) [BC557/116](#) [BSW67A](#) [HN7G01FU-A\(T5L,F,T](#)
[NJVMJD148T4G](#) [NSVMMBT6520LT1G](#) [NTE187A](#) [NTE195A](#) [NTE2302](#) [NTE2330](#) [NTE2353](#) [NTE316](#) [IMX9T110](#) [NTE63](#) [NTE65](#)
[C4460](#) [SBC846BLT3G](#) [2SA1419T-TD-H](#) [2SA1721-O\(TE85L,F\)](#) [2SA1727TLP](#) [2SA2126-E](#) [2SB1202T-TL-E](#) [2SB1204S-TL-E](#) [2SC5488A-](#)
[TL-H](#) [2SD2150T100R](#) [SP000011176](#) [FMC5AT148](#) [2N2369ADCSM](#) [2SB1202S-TL-E](#) [2SC2412KT146S](#) [2SC4618TLN](#) [2SC5490A-TL-H](#)
[2SD1816S-TL-E](#) [2SD1816T-TL-E](#) [CMXT2207 TR](#) [CPH6501-TL-E](#) [MCH4021-TL-E](#) [BC557B](#) [TTC012\(Q\)](#) [BULD128DT4](#) [JANTX2N3810](#)
[Jantx2N5416](#) [US6T6TR](#) [KSF350](#) [068071B](#)