

NTE123

Silicon NPN Transistor

General Purpose Audio Amplifier, Switch

Absolute Maximum Ratings:

Collector–Emitter Voltage, V_{CEO}	40V
Collector–Base Voltage, V_{CBO}	75V
Emitter–Base Voltage, V_{EBO}	6V
Continuous Collector Current, I_C	800mA
Total Device Dissipation ($T_A = +25^\circ\text{C}$), P_D	800mW
Derate Above 25°C	5.33mW/ $^\circ\text{C}$
Total Device Dissipation ($T_C = +25^\circ\text{C}$), P_D	3.0W
Derate Above 25°C	20mW/ $^\circ\text{C}$
Operating Junction Temperature Range, T_J	-65° to $+200^\circ\text{C}$
Storage Temperature Range, T_{stg}	-65° to $+200^\circ\text{C}$

Electrical Characteristics: ($T_A = +25^\circ\text{C}$ unless otherwise specified)

Parameter	Symbol	Test Conditions	Min	Typ	Max	Unit
OFF Characteristics						
Collector–Emitter Breakdown Voltage	$V_{(BR)CEO}$	$I_C = 10\text{mA}$, $I_B = 0$	40	–	–	V
Collector–Base Breakdown Voltage	$V_{(BR)CBO}$	$I_C = 10\mu\text{A}$, $I_E = 0$	75	–	–	V
Emitter–Base Breakdown Voltage	$V_{(BR)EBO}$	$I_E = 10\mu\text{A}$, $I_C = 0$	6	–	–	V
Collector Cutoff Current	I_{CBO}	$V_{CE} = 60\text{V}$, $I_E = 0$	–	–	0.01	μA
		$V_{CE} = 60\text{V}$, $I_E = 0$, $T_A = +150^\circ\text{C}$	–	–	10	μA
	I_{CEX}	$V_{CE} = 60\text{V}$, $V_{EB(off)} = 3\text{V}$	–	–	10	nA
Emitter Cutoff Current	I_{EBO}	$V_{EB} = 3\text{V}$, $I_C = 0$	–	–	10	nA
Base Cutoff Current	I_{BL}	$V_{CE} = 60\text{V}$, $V_{EB(off)} = 3\text{V}$	–	–	20	nA

Electrical Characteristics (Cont'd): ($T_A = +25^\circ\text{C}$ unless otherwise specified)

Parameter	Symbol	Test Conditions	Min	Typ	Max	Unit
ON Characteristics (Note 1)						
DC Current Gain	h_{FE}	$I_C = 0.1\text{mA}, V_{CE} = 10\text{V}$	35	–	–	
		$I_C = 1\text{mA}, V_{CE} = 10\text{V}$	50	–	–	
		$I_C = 10\text{mA}, V_{CE} = 10\text{V}$	75	–	–	
		$I_C = 10\text{mA}, V_{CE} = 10\text{V}, T_A = -55^\circ\text{C}$	35	–	–	
		$I_C = 150\text{mA}, V_{CE} = 10\text{V}$	100	–	300	
		$I_C = 150\text{mA}, V_{CE} = 1.0\text{V}$	50	–	–	
		$I_C = 500\text{mA}, V_{CE} = 10\text{V}$	40	–	–	
Collector–Emitter Saturation Voltage	$V_{CE(sat)}$	$I_C = 150\text{mA}, I_B = 15\text{mA}$	–	–	0.3	V
		$I_C = 500\text{mA}, I_B = 50\text{mA}$	–	–	1.0	V
Base–Emitter Saturation Voltage	$V_{BE(sat)}$	$I_C = 150\text{mA}, I_B = 15\text{mA}$	0.6	–	1.2	V
		$I_C = 500\text{mA}, I_B = 50\text{mA}$	–	–	2.0	V
Small–Signal Characteristics						
Current Gain–Bandwidth Product	f_T	$I_C = 20\text{mA}, V_{CE} = 20\text{V}, f = 100\text{MHz}, \text{Note 2}$	300	–	–	MHz
Output Capacitance	C_{obo}	$V_{CB} = 10\text{V}, I_E = 0, f = 100\text{kHz}$	–	–	8	pF
Input Capacitance	C_{ibo}	$V_{EB} = 0.5\text{V}, I_C = 0, f = 100\text{kHz}$	–	–	25	pF
Input Impedance	h_{ie}	$I_C = 1\text{mA}, V_{CE} = 10\text{V}, f = 1\text{kHz}$	2.0	–	8.0	k Ω
		$I_C = 10\text{mA}, V_{CE} = 10\text{V}, f = 1\text{kHz}$	0.25	–	1.25	k Ω
Voltage Feedback Ratio	h_{re}	$I_C = 1\text{mA}, V_{CE} = 10\text{V}, f = 1\text{kHz}$	–	–	8	$\times 10^{-4}$
		$I_C = 10\text{mA}, V_{CE} = 10\text{V}, f = 1\text{kHz}$	–	–	4	$\times 10^{-4}$
Small–Signal Current Gain	h_{fe}	$I_C = 1\text{mA}, V_{CE} = 10\text{V}, f = 1\text{kHz}$	50	–	300	
		$I_C = 10\text{mA}, V_{CE} = 10\text{V}, f = 1\text{kHz}$	75	–	375	
Output Admittance	h_{oe}	$I_C = 1\text{mA}, V_{CE} = 10\text{V}, f = 1\text{kHz}$	5.0	–	35	μmhos
		$I_C = 10\text{mA}, V_{CE} = 10\text{V}, f = 1\text{kHz}$	25	–	200	μmhos
Collector–Base Time Constant	$r_b' C_C$	$I_E = 20\text{mA}, V_{CB} = 20\text{V}, f = 31.8\text{MHz}$	–	–	150	ps
Noise Figure	NF	$I_C = 100\mu\text{A}, V_{CE} = 10\text{V}, R_S = 1\text{k}\Omega, f = 1\text{kHz}$	–	–	4	dB
Real Part of Common–Emitter High Frequency Input Impedance	$\text{Re}(h_{ie})$	$I_C = 20\text{mA}, V_{CE} = 20\text{V}, f = 300\text{MHz}$	–	–	60	Ω
Switching Characteristics						
Delay Time	t_q	$V_{CC} = 30\text{V}, V_{BE(off)} = 0.5\text{V}, I_C = 150\text{mA}, I_{B1} = 15\text{mA}$	–	–	10	ns
Rise Time	t_r		–	–	25	ns
Storage Time	t_s	$V_{CC} = 30\text{V}, I_C = 150\text{mA}, I_{B1} = I_{B2} = 15\text{mA}$	–	–	225	ns
Fall Time	t_f		–	–	60	ns
Active Region Time Constant	T_A	$I_C = 150\text{mA}, V_{CE} = 30\text{V}$	–	–	2.5	ns

Note 1. Pulse Test: Pulse Width $\leq 300\mu\text{s}$, Duty Cycle $\leq 2\%$.

Note 2. f_T is defined as the frequency at which $|h_{fe}|$ extrapolates to unity.

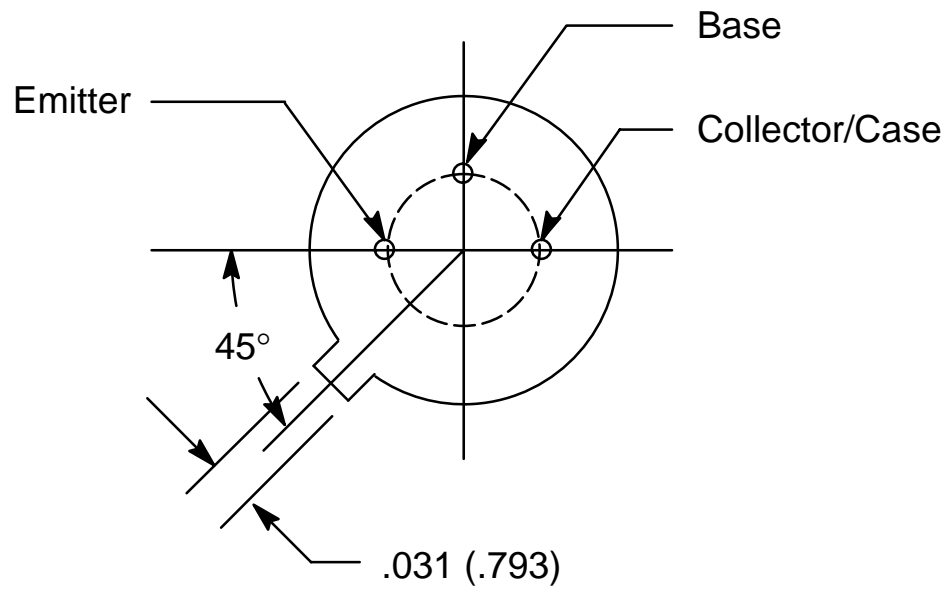
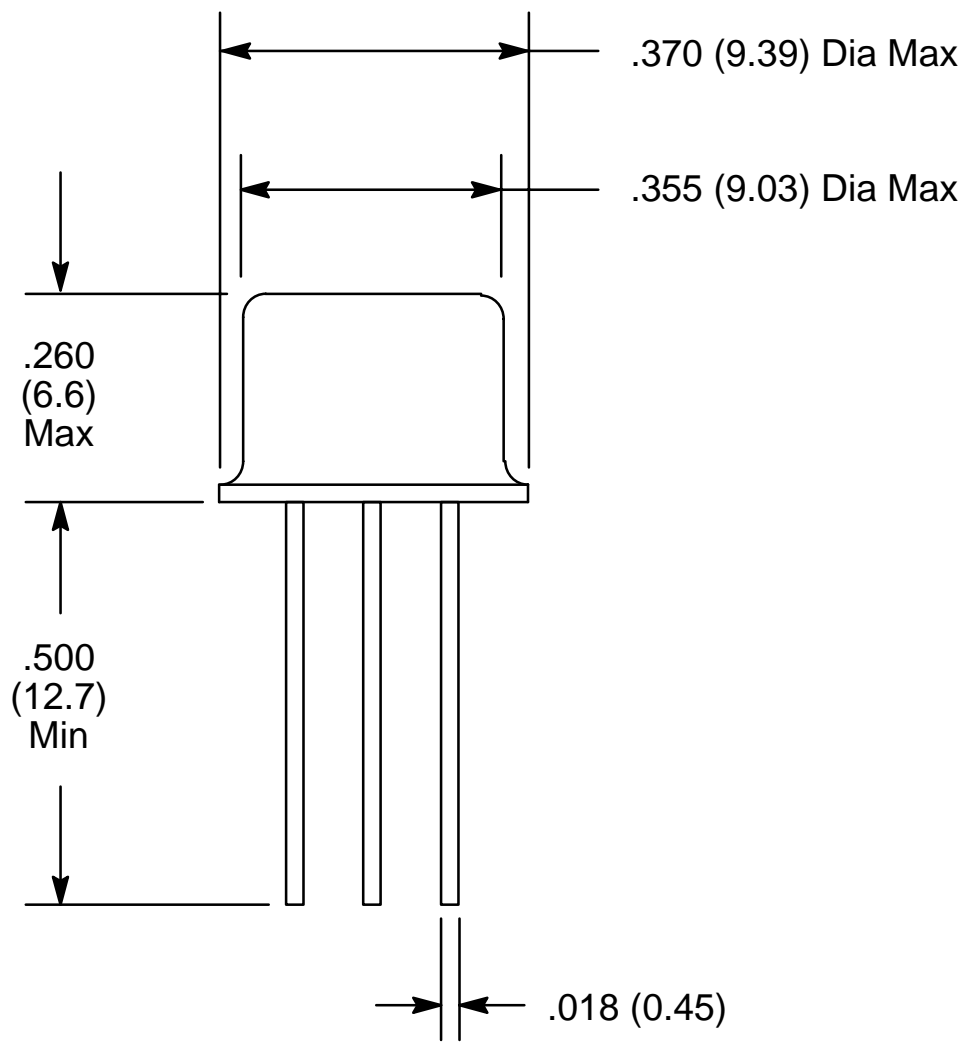

X-ON Electronics

Largest Supplier of Electrical and Electronic Components

Click to view similar products for [Bipolar Transistors - BJT category](#):

Click to view products by [NTE manufacturer](#):

Other Similar products are found below :

[619691C](#) [MCH4017-TL-H](#) [MJ15024/WS](#) [MJ15025/WS](#) [BC546/116](#) [BC556/FSC](#) [BC557/116](#) [BSW67A](#) [HN7G01FU-A\(T5L,F,T](#)
[NJVMJD148T4G](#) [NSVMMBT6520LT1G](#) [NTE187A](#) [NTE195A](#) [NTE2302](#) [NTE2330](#) [NTE2353](#) [NTE316](#) [IMX9T110](#) [NTE63](#) [NTE65](#)
[C4460](#) [SBC846BLT3G](#) [2SA1419T-TD-H](#) [2SA1721-O\(TE85L,F\)](#) [2SA1727TLP](#) [2SA2126-E](#) [2SB1202T-TL-E](#) [2SB1204S-TL-E](#) [2SC5488A-](#)
[TL-H](#) [2SD2150T100R](#) [SP000011176](#) [FMC5AT148](#) [2N2369ADCSM](#) [2SB1202S-TL-E](#) [2SC2412KT146S](#) [2SC4618TLN](#) [2SC5490A-TL-H](#)
[2SD1816S-TL-E](#) [2SD1816T-TL-E](#) [CMXT2207 TR](#) [CPH6501-TL-E](#) [MCH4021-TL-E](#) [BC557B](#) [TTC012\(Q\)](#) [BULD128DT4](#) [JANTX2N3810](#)
[Jantx2N5416](#) [US6T6TR](#) [KSF350](#) [068071B](#)