



Typical unit

Output Voltage (V)	Output Current (A)	Input Voltage Range (V)
12	12.5	16-160
24	6.25	16-160
54	2.75	16-160

Optimized for harsh environments in industrial/railway applications, the IRQ DC-DC converter series offer regulated outputs in an industry-standard quarter brick fully encased package.

FEATURES

- Efficiency up to 89% @ 72Vin, 12Vout
- Ultra-wide input range: 16V-160V
- Output voltage: 12V, 24V or 54V
- Vout trim
- Output power 150W
- Quarter-Brick Package: 61.24x39.63x13.5 mm
2.41x1.56x0.53 inches
- OVP, OCP, OTP.
- Positive or Negative Remote ON/OFF.
- Operating Baseplate Temperature range
-40°C to +100°C.
- 4242VDC input to output isolation, reinforced.
- Hold Up Time (10-30mS, with external Cap)
- UVLO Set up (resistor programmable)
- Meets requirements for EN50155

SAFETY FEATURES

- Reinforced insulation
- UL 60950-1, 2nd Edition (Pending)
- CSA-C22.2 No. 60950-1 (Pending)
- IEC/EN60950-1, 2nd edition (Pending)
- RoHS compliant



PRODUCT OVERVIEW

The IRQ series of isolated, regulated converter modules deliver an impressive 150W output power from an ultra-wide 10:1 input voltage range, complying with the 24V to 110V input battery voltages including transients as per EN50155 (2017) standard. The converter comes in a fully encased industry standard quarter brick package offering astonishing efficiencies. The fully isolated (4242Vdc) IRQ series features a 16 to 160 Volt DC input voltage range. Typical applications

include industrial, railway and transportation. The IRQ's diode rectifier topology and fixed frequency operations means excellent efficiencies of up to 89%. A wealth of electronic protection features include input under voltage lockout, output over voltage lockout protection, output current limit, current sharing, short circuit hiccup, Vout overshoot, and over temperature shutdown.

The IRQ series is designed to meet all UL and IEC emissions, safety, and flammability certifications.

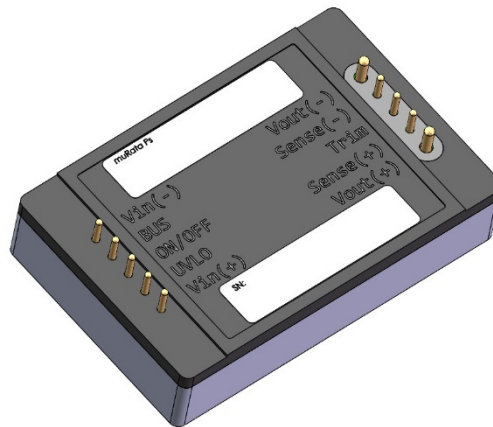

Encapsulated Quarter-Brick

PERFORMANCE SPECIFICATIONS SUMMARY AND ORDERING GUIDE [1] [2]													
Root Model [1]	Output							Input				Efficiency	Package
	V _{out} (V)	I _{out} (A, max.)	Power (W)	Ripple & Noise (mV pk-pk)		Regulation [3] (max.)		V _{in} Nom. (V)	V _{in} Range (V)	I _{in} , no load (mA)	I _{in} , full load (A)	Typ.	Case (mm)
				Typ.	Max.	Line	Load						
IRQ-12/12.5-W80	12	12.5	150	100	160	±0.5%	±0.5%	72	16-160	60	12	89%	61.24 x 39.63 x 13.5
IRQ-24/6.25-W80	24	6.25	150	200	280	±0.25%	±0.25%	72	16-160	70	12	89%	61.24 x 39.63 x 13.5
In Development	54	2.75	150	300	400	±0.5%	±0.5%	72	16-160	90	12	89%	61.24 x 39.63 x 13.5

Notes:

- [1] Please refer to the Part Number Structure when ordering.
- [2] All specifications are at nominal line voltage and full load, +25°C unless otherwise noted. See detailed specifications. Output capacitors are 1µF ceramic multilayer in parallel with 10µF. I/O caps are necessary for our test equipment and may not be needed for your application.
- [3] Regulation specifications describe output voltage deviations from a nominal/midpoint value to either extreme (50% load step).

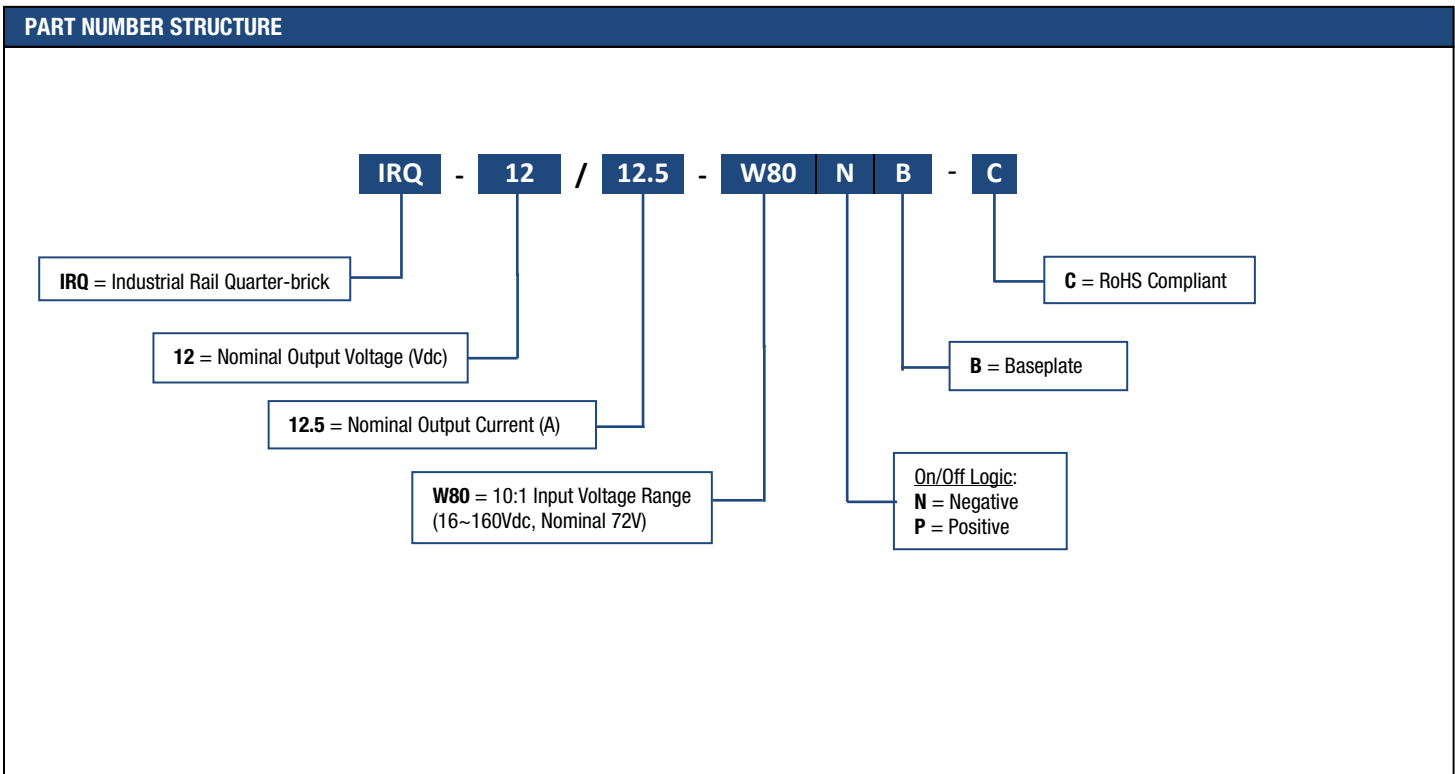

FUNCTIONAL SPECIFICATIONS: IRQ-12/12.5-W80

ABSOLUTE MAXIMUM RATINGS	NOTES AND CONDITIONS	MIN.	TYP.	MAX.	UNITS
Input Voltage					
Non-Operating	Continuous	0		160	Vdc
Operating	Continuous	16		160	Vdc
Transient Operating	100mS			160	Vdc
Operating Ambient Temperature		-40		85	°C
Operating Baseplate Temperature		-40		100	°C
Storage Temperature		-55		125	°C
Input/Output Isolation Voltage				4242	Vdc
Voltage at ON/OFF input pin		0		15	Vdc
General conditions for device under Test unless otherwise specified: Ambient temperature +25°C; Vin typical; Vout nominal load; Encapsulated Package; With 1μF&10μF capacitors across output pins; No external input capacitors.					
INPUT CHARACTERISTICS					
Operating Input Voltage Range		16	72	160	Vdc
Input Under-Voltage Lockout					
Turn-On Voltage Threshold		14.0	15.0	16.0	Vdc
Turn-Off Voltage Threshold		11.0	12.0	13.0	Vdc
Lockout Voltage Hysteresis			3		Vdc
Maximum Input Current	Full Load, Vin=16V			12	A
No-Load Input Current	Vin=72V		40	60	mA
Disabled Input Current (N suffix)			10	15	mA
Disabled Input Current (Blank suffix)			10	15	mA
Input Reflected Ripple Current	RMS thru 220μF/250V, 12μF across source, 33μF/250V external capacitors across input pins, Note 1		100	100	mArms
Input Terminal Ripple Current	RMS, 20MHz bandwidth, Note 1		4.5	5	Arms
Recommended Input Fuse	Fast acting external fuse recommended			15	A
Recommended External Input Capacitance			220		μF
Recommended BUS Capacitance	2pcs 120μF/250Vdc and MPN is EKXJ251ELL121ML25S		240		μF
Inrush Current (I ^{pt})			25	30	A ² S
OUTPUT CHARACTERISTICS					
Total Output Power	See Derating		150	150	W
Output Voltage Set Point	Vin=Nominal, Io=0A, Ta=25°C	11.88	12	12.12	Vdc
Output Voltage Regulation					
Over Load	Vin=72V, Iout from Min to Max		±0.5		%
Over Line	Iout=Full load, Vin from Min to Max. Note 2		±0.5		%
Over Temperature	Vin=72V, Ta=-40°C to 85°C		±0.004	±0.01	mV
Total Output Voltage Range	Over sample, line, load, temperature & life	11.64		12.36	Vdc
Output Voltage Ripple and Noise	20MHz bandwidth				
Peak-to-Peak	Full Load, 1μF ceramic, 10μF tantalum		100	160	mVp-p
RMS	Full Load, 1μF ceramic, 10μF tantalum		30	50	mVrms
Peak-to-Peak	All conditions, 1μF ceramic, 10μF tantalum			160	mVp-p
RMS	All conditions, 1μF ceramic, 10μF tantalum			50	mVrms
Operating Output Current Range		0	12.5	12.5	A
Output DC Current-Limit Inception	Output Voltage 10% Low	14	18	22	A
Output Capacitance	Nominal Vout at full load (CR load)	0		2200	μF
	Nominal Vout at full load (CC load)	0		2200	μF
EFFICIENCY					
100% Load	Vin=Nominal; Details see Figures		89		%
50% Load	Vin=Nominal; Details see Figures		88		%
DYNAMIC CHARACTERISTICS					
Output Voltage During Load Current Transient					
Step Change in Output Current (1A/uS)	50% to 75% to 50% Iout max, 1uF+10uF load cap		250	400	mV
Settle Time	To within 1% Vout nom		75	150	uS
Turn-On Transient					
Start-up Time, From ON/OFF Control	To Vout=90% nominal			460	mS
Start-up Time, From Input	To Vout=90% nominal			460	mS

FUNCTIONAL SPECIFICATIONS: IRQ-12/12.5-W80

Rise Time	Time from 10% to 90% of nominal output voltage			25	mS	
Output Voltage Overshoot				2	%	
ISOLATION CHARACTERISTICS		NOTES AND CONDITIONS	MIN.	TYP.	MAX.	UNITS.
Insulation Safety Rating			Functional			
Input to Output				4242	Vdc	
Input to Baseplate				2250	Vdc	
Output to Baseplate				2250	Vdc	
Isolation Resistance	Input/Output			10	MΩ	
Isolation Capacitance	Input/Output			750	pF	
TEMPERATURE LIMITS FOR POWER DERATING CURVES						
Semiconductor Junction Temperature				Tjmax-25	°C	
Board Temperature	UL rated max operating temp 130°C			130	°C	
Transformer/Inductor Temperature				130	°C	
FEATURE CHARACTERISTICS						
Switching Frequency	See from Input Terminals	190	210	230	kHz	
ON/OFF Control (Blank suffix)						
Off-State Voltage		0		0.7	V	
On-State Voltage	Open the ON/OFF pin = ON	2		15	V	
ON/OFF Control (N suffix)						
Off-State Voltage	Open the ON/OFF pin = OFF	2		15	V	
On-State Voltage		0		0.7	V	
ON/OFF Control Current (Either Option)						
Current thru ON/OFF pin	Von/off=0V		1	2	mA	
Current thru ON/OFF pin	Von/off=15V			1	uA	
Remote Sense Compensation			10		%	
Output Voltage Trim Range	Pout<=Max rated power	-10		10	%	
Trim Up Equations	Please see TRIM functions in Technical Notes					
Trim Down Equations	Please see TRIM functions in Technical Notes					
Output Over-Voltage Protection	Hiccup mode; over full temp range; % of nominal Vout	115	125	150	%	
Over-Temperature Shutdown						
With Baseplate	Refer to Figure for Hot spot location		125		°C	
Restart Hysteresis			6		°C	
THERMAL IMPEDANCE						
Vin=16.8V	Full load, component to baseplate		1.18		K/W	
Vin=24V	Full load, component to baseplate		1.26		K/W	
Vin=28V	Full load, component to baseplate		1.28		K/W	
Vin=36V	Full load, component to baseplate		1.31		K/W	
Vin=48V	Full load, component to baseplate		1.36		K/W	
Vin=72V	Full load, component to baseplate		1.48		K/W	
Vin=96V	Full load, component to baseplate		1.56		K/W	
Vin=110V	Full load, component to baseplate		1.51		K/W	
Vin=137.5V	Full load, component to baseplate		1.59		K/W	
RELIABILITY/SAFETY/ENVIRONMENTAL						
Safety	Certified to UL 60950-1, CSA-C22.2 No.60950-1, IEC/EN 60950-1, 2nd Edition		Pending			
Calculated MTBF	Per Telcordia SR332, Issue 2, Method 1, Class 1		1.48		MHrs	
Conducted Emissions	External filter is required, see technical notes		EN55022/CISPR22 CLASS B			
MECHANICAL						
Outline Dimensions		2.41 x 1.56 x 0.53			Inches	
(Please refer to outline drawing)	L x W x H	61.24 x 39.63 x 13.5			mm	
Weight		TBD			Ounces	
		TBD			Grams	
Through Hole Pin Diameter		0.04 & 0.06			Inches	

TYPICAL PERFORMANCE DATA: IRQ-12/12.5-W80

IRQ-12/12.5-W80 Efficiency vs Pout

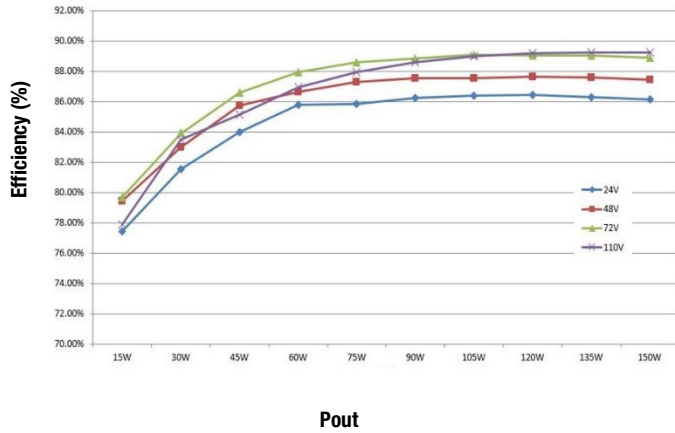

IRQ-12/12.5-W80 Power Dissipation vs Load

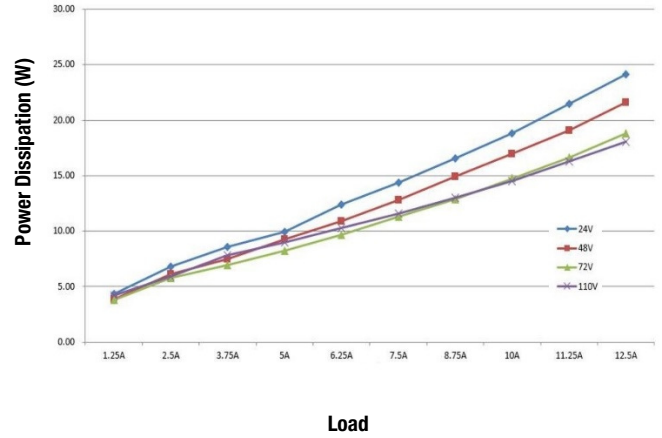

IRQ-12/12.5-W80 Temperature Derating

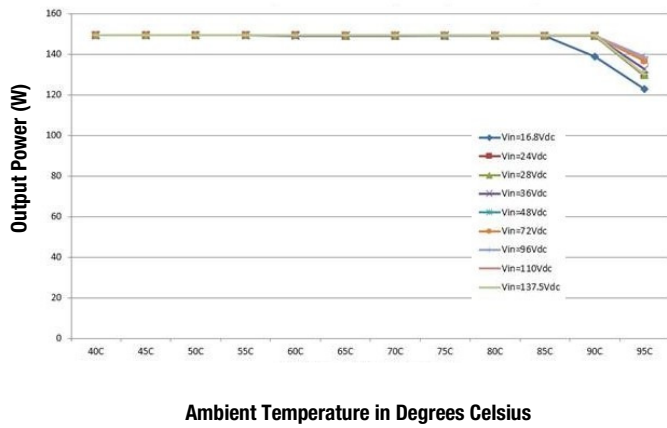

Cold Wall Testing – See Technical Notes

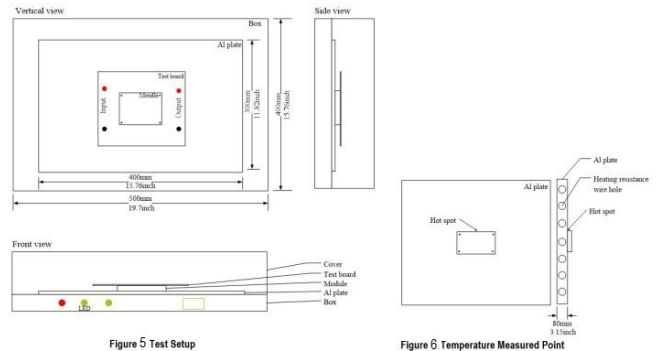

Turn On Transient VS Vin @ 72V with Full load with 2200uF load caps

Turn On Transient VS Enable @ 72V with Full load with 2200uF load caps

QUALIFICATION TESTS:

Parameters	Test Conditions	Operating
Vibration	EN 61373:2010 Clause8 , Bogie mounted	Yes
Mechanical Shock	EN 61373:2010 Clause10 , Bogie mounted	Yes
DMTBF (Life Test)	Vin nom, units at derating point, 35days	Yes
Temperature Cycling Test (TCT)	-40°C to 125°C, unit temp. ramp 15°C/min., 500cycles	Yes
Temperature, Humidity and Bias (THB)	85°C, 85RH, Vin=max, Load=min load, 1072Hour (72hours with a pre-conditioning soak, unpowered)	No
Damp heat test, cyclic	EN60068-2-30: Temperature +55°C and +25°C; Number of cycles 2 (respiration effect); Time 2 x 24 hours; Relative Humidity 95%	No
Dry heat test	EN60068-2-2, Vin=nom, Full load, 85°C for 6 hours.	Yes
Low Temperature operating	Vin=nom, Full load, -40°C for 2 hours.	Yes
Highly Accelerated Life Test (HALT)	High temperature limits, low temperature limits, Vibration limits, Combined Environmental Tests.	Yes
EMI	CISPR 22 Class A, or IEC62236-3-2 (GB/T 24338.4)	Yes
ESD	IEC6100-4-2: ±6kV contact discharge / ±8kV air discharge	Yes
Surge Protection	IEC/EN 61000-4-5	Yes
Solderability	IPC/EIAJ-STD-002B (Solderability Tests for Component Leads, Terminations, Lugs, Terminals and Wires)	No

MECHANICAL SPECIFICATIONS

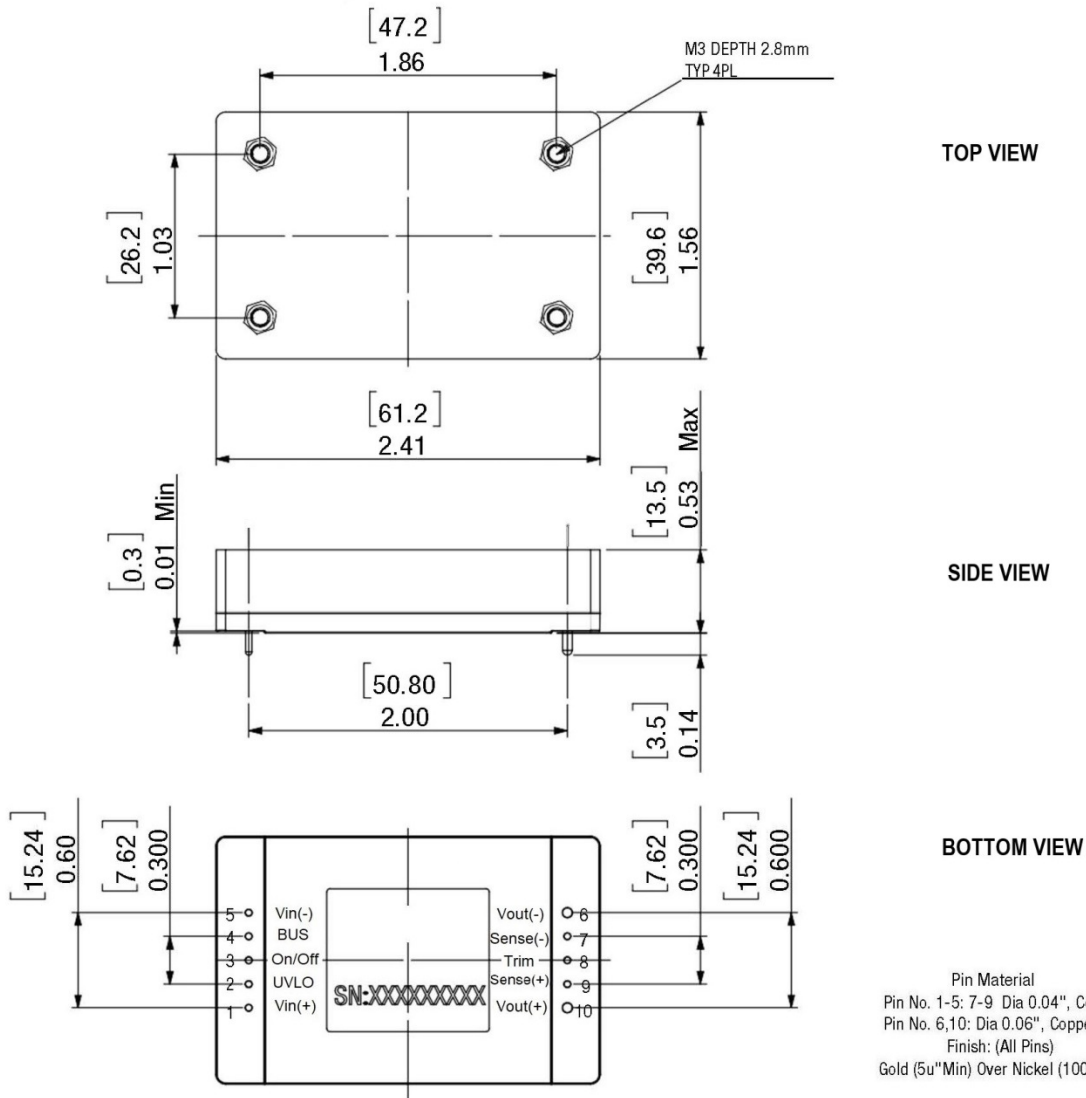

Dimensions are in inches (mm) shown for ref. only.

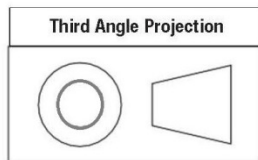

Tolerances (unless otherwise specified):
 .XX ± 0.02 (0.5)
 .XXX ± 0.010 (0.25)
 Angles ± 1°

Pin	Function	Pin	Function
1	Vin(+)	6	Vout(-)
2	UVLO	7	Sense(-)
3	On/Off	8	Trim
4	BUS	9	Sense(+)
5	Vin(-)	10	Vout(+)

RECOMMENDED FOOTPRINT SPECIFICATIONS

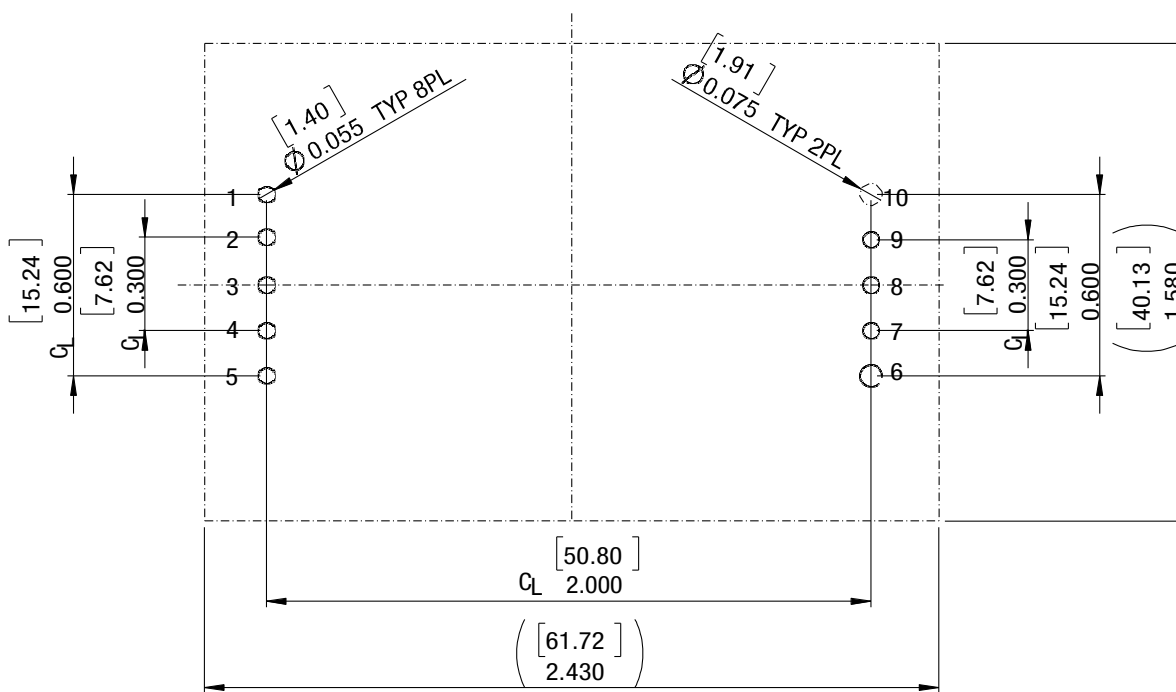

FOOTPRINT RECOMMENDATION – TOP VIEW

Dimensions are in inches (mm) shown for ref. only.

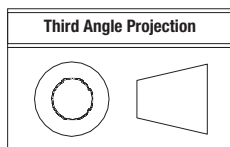

Tolerances (unless otherwise specified):
 .XX ± 0.02 (0.5)
 .XXX ± 0.010 (0.25)
 Angles ± 1°

Pin	Function	Pin	Function
1	Vin(+)	6	Vout(-)
2	UVLO	7	Sense(-)
3	On/Off	8	Trim
4	BUS	9	Sense(+)
5	Vin(-)	10	Vout(+)

SHIPPING BOX AND TRAY DIMENSIONS

ITEM NO. (7770546)	PART NUMBER	DESCRIPTION	QTY
1	2300208	SHIPPING BOX, 10" X 10" X 2.50"	3
2	2300221	SHIPPING TRAY BASE (PAD) .75" THICK	3 (NOTE 8)
3	2300234	SHIPPING TRAY, 1/4 BRICK (15 CAVITY)	6
4	2300159	LABEL, 1.0" X 1.5" PAPER	3
5	5600-01098-0	LABEL, PRE-PRINTED ESD ATTENTION	3
6	5652-01166-0	LABEL, PAPER, 2.0" X 4.0"	3 (NOTE 6)
7	6200-01211-0	ESD TAPE, 3/4" WIDE	1.0'
8	6256-01125-0	ESD PAD 335mm X 305mm	2
9	6256-01124-0	ESD PAD 335mm X 225mm	2
10	6256-01126-0	ESD PAD 255mm X 225mm	2
11	6256-01127-0	RIGHT ANGLE CLIP	4
12	6256-01128-0	OUTER PACKAGE CARTON	1

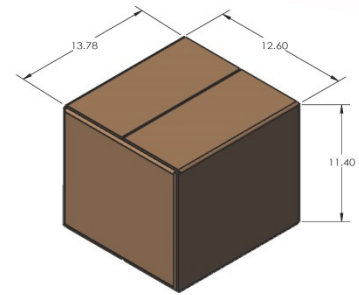
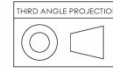

ITEM NUMBERS REFER TO 7770546 BOM. ITEMS ABOVE ARE FOR REFERENCE ONLY, REFER TO APPROPRIATE BOM FOR COMPLETE LIST OF PARTS

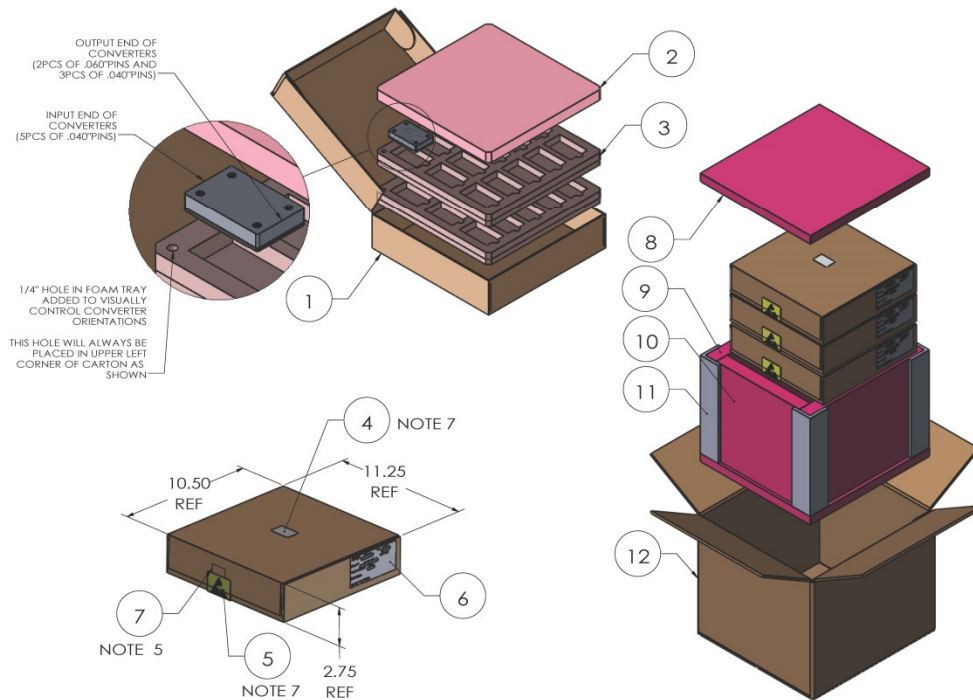

NOTES:

1. THIS DOCUMENT DEFINES THE GENERAL PACKING RULES FOR APPLICABLE SHIPPING KIT. INFORMATION FOR SEALING AND MARKING IS NOT PART OF THIS DOCUMENT.
2. REFER TO SHIPPING KIT BOM DETAILS.
3. INSERT UNITS INTO FOAM POCKETS IN TRAYS APPROX AS SHOWN
4. EACH FOAM TRAY (ITEM3) CONTAINS 15 UNITS. EACH BOX (ITEM 1) CONTAINS 30 UNITS. IN FULL CARTON ITEM12 QUANTITIES, 3 BOXES (ITEM 1) EQUAL A TOTAL OF 90 UNITS.
5. IF SHIPPING QTY IS 30PCS, PLEASE ALSO USE ITEM12 TO MAKE THE PACKAGE TWO EMPTY BOX ITEM1 PUT ON THE BOX ITEM1 WITH PRODUCTS).
6. FRONT FLAP SHALL BE SEALED WITH ESD TAPE SPECIFIED OR EQUIVALENT AFTER THE BOX IS CLOSED.
7. LABEL (ITEM 6) USED FOR MFR OVERPACK CARTON
8. APPLY ESD LABEL (ITEM 5) OVER TAPE USED TO SEAL BOX AND APPLY IDENTIFICATION LABEL (ITEM 4) APPROX AS SHOWN.
9. PAD (ITEM 2) MAY, AT MFR'S OPTION, BE EXCHANGED FOR THINNER PAD IF FOAM STACKUP EXCEEDS CARTON HEIGHT BY >1/8" OR ADDITIONAL PAD MAY BE ADDED IF STACKUP IS BELOW INSIDE CARTON HEIGHT BY >1/8". ALTERNATE PADS: 1/4" THK=2300216, 3/8" THK=2300218, 1/2" THK=2300219, 3/4" THK=2300221

TECHNICAL NOTES

On/Off Control

The input-side, remote On/Off Control function (pin 3) can be ordered to operate with either logic type:

Negative (“N” suffix): Negative-logic devices are off when pin 3 is left open (or pulled high, applying +3V to +5V), and on when pin 3 is pulled low (0 to 0.4V) with respect to –Input as shown in Figure 1.

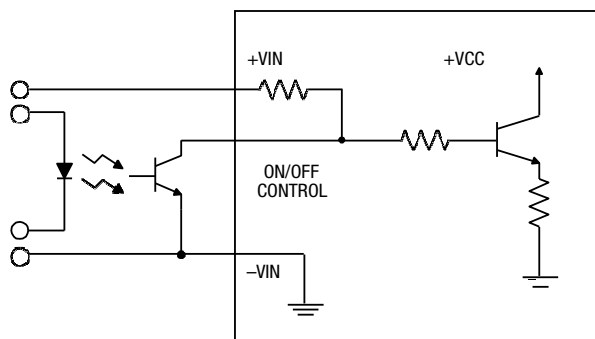

Figure 1. Driving the Negative Logic On/Off Control Pin

Dynamic control of the remote on/off function is best accomplished with a mechanical relay or an open-collector/open-drain drive circuit (optically isolated if appropriate). The drive circuit should be able to sink appropriate current (see Performance Specifications) when activated and withstand appropriate voltage when deactivated. Applying an external voltage to pin 3 when no input power is applied to the converter can cause permanent damage to the converter.

Input Fusing

Certain applications and/or safety agencies may require fuses at the inputs of power conversion components. Fuses should also be used when there is the possibility of sustained input voltage reversal which is not current-limited. For greatest safety, we recommend a fast blow fuse installed in the ungrounded input supply line.

Vin	Fuse Rate Current
24V	15A fast
48V	8A fast
72V	5A fast
110V	3A fast

Figure 2. Typical Recommended Fuse Value

Input Under-Voltage Shutdown and Start-Up Threshold

Under normal start-up conditions, converters will not begin to regulate properly until the rising input voltage exceeds and remains at the Start-Up Threshold Voltage (see Specifications). Once operating, converters will not turn off until the input voltage drops below the Under-Voltage Shutdown Limit. Subsequent restart will not occur until the input voltage rises again above the Start-Up Threshold. This built-in hysteresis prevents any unstable on/off operation at a single input voltage. Figure 3 shows a typical configuration.

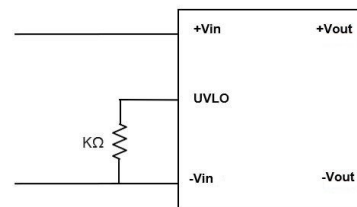

Figure 3. Under Voltage Lockout Configuration

The table below shows UVLO values for various nominal input voltages and the required resistor for each.

Nominal Vin	24V	36V	48V	72V	96V	110V
Turn-off Threshold	12±1V	20.5±1V	29±1V	43±1.5V	60.5±2V	64.3±2V
Turn-on threshold	15±1V	23.5±1V	32±1V	46±1.5V	63.8±2V	67.3±2V
UVLO External Resistor	open	20.5k	10.7k	5.9k	3.74k	3.48k

Hold-Up Time and BUS Capacitor

The BUS+ pin is for hold-up time function. It is designed to work with an external circuit comprises a cap (Chold), a resistor and a diode.(Hold up time is defined as the duration of time that the DC/DC converter output will remain active following a loss of input power). When this function is activated, the module will use the energy stored in external circuit to support operation. A typical configuration is shown in Figure 4 below.

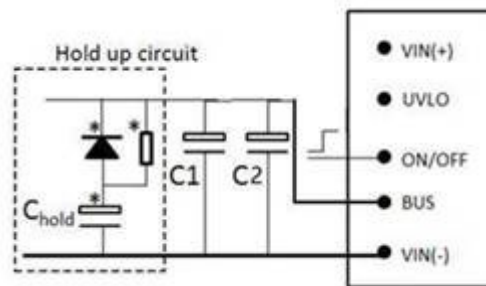

Figure 4. Connection of External Hold-up Circuit

NOTE: Two electrolytic caps (low ESR preferred) connected between BUS+ and Vin- (C1 and C2 in Figure 4) is necessary for stability, and the recommended capacitance is 120uF/250V and MPN is EKXJ251ELL121ML25S. This function provides energy that maintains the DC/DC converter in operation for 10mS/ 30mS

of hold up time. The capacitance in the application is recommended in the hold-up table below.

CBUSmin	68uF					
Hold up time	24V	36V	48V	72V	96V	110V
10ms	1800uF	1800uF	1800uF	1800uF	550uF	330uF
20ms	3600uF	3600uF	3600uF	3600uF	1100uF	660uF
30ms	5400uF	5400uF	5400uF	5400uF	1650uF	990uF

NOTE: The resistor value recommended is 100ohm.

Start-Up Time

Assuming that the output current is set at the rated maximum, the Vin to Vout Start-Up Time (see Specifications) is the time interval between the point when the rising input voltage crosses the Start-Up Threshold and the fully loaded output voltage enters and remains within its specified accuracy band. Actual measured times will vary with input source impedance, external input capacitance, input voltage slew rate and final value of the input voltage as it appears at the converter.

These converters include a soft start circuit to moderate the duty cycle of its PWM controller at power up, thereby limiting the input inrush current.

The On/Off Remote Control interval from On command to Vout (final ±2%) assumes that the converter already has its input voltage stabilized above the Start-Up Threshold before the On command. The interval is measured from the On command until the output enters and remains within its specified accuracy band. The specification assumes that the output is fully loaded at maximum rated current. Similar conditions apply to the On to Vout regulated specification such as external load capacitance and soft start circuitry.

Recommended Input Filtering

The user must assure that the input source has low AC impedance to provide dynamic stability and that the input supply has little or no inductive content, including long distributed wiring to a remote power supply. The converter will operate with no additional external capacitance if these conditions are met.

For best performance, we recommend installing a low-ESR capacitor immediately adjacent to the converter’s input terminals. The capacitor should be a ceramic type such as the Murata GRM32 series or a polymer type. Make sure that the input terminals do not go below the undervoltage shutdown voltage at all times. More input bulk capacitance may be added in parallel (either electrolytic or tantalum) if needed.

Recommended Output Filtering

The converter will achieve its rated output ripple and noise with no additional external capacitor. However, the user may install more external output capacitance to reduce the ripple even further or for improved dynamic response.

Again, use low-ESR ceramic (Murata GRM32 series) or polymer capacitors. Mount these close to the converter. Measure the output ripple under your load conditions.

Use only as much capacitance as required to achieve your ripple and noise objectives. Excessive capacitance can make step load recovery sluggish or possibly introduce instability. Do not exceed the maximum rated output capacitance listed in the specifications.

Input Ripple Current and Output Noise

All models in this converter series are tested and specified for input reflected ripple current and output noise using designated external input/output components, circuits and layout as shown in the figures below. The Cbus and Lbus components simulate a typical DC voltage bus.

Output Over-Voltage Protection

The IRQ output voltage is monitored for an over-voltage condition using a comparator. The signal is optically coupled to the primary side and if the output voltage rises to a level which could be damaging to the load, the sensing circuitry will disable the PWM controller drive causing the output voltage to decrease. It is referred to as “latch” mode.

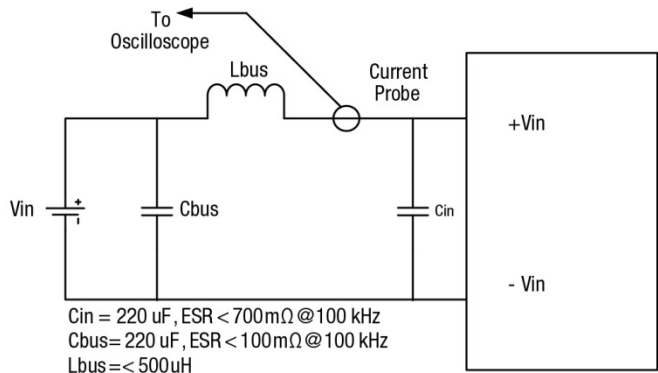

Figure 5. Measuring Input Ripple Current

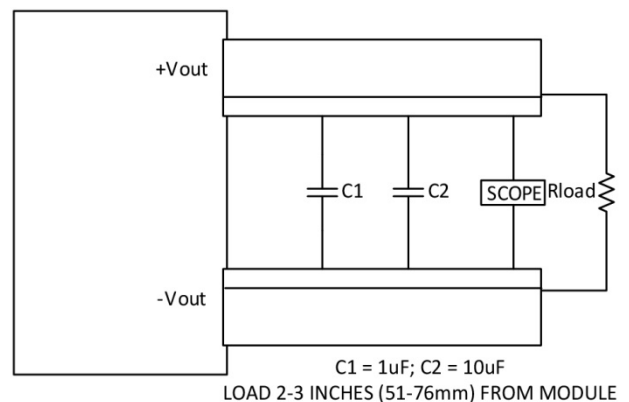

Figure 6. Measuring Output Ripple and Noise (PARD)

Minimum Output Loading Requirements

All models regulate within specification and are stable under no load to full load conditions. Operation under no load might however slightly increase output ripple and noise.

Over-Temperature Protection

The over-temperature protection consists of circuitry that provides protection from thermal damage. If the over-temperature is detected the module will shut down, and restart after the temperature is within specification.

Temperature Derating Curves

The thermal derating curve is based on the best setup shown in Figure 7. The module is mounted on an Al plate and was cooled by resistance wire. Figure 8 shows the location to monitor the temperature of the module's baseplate. The baseplate temperature in thermal derating curve is a reference for customer to make thermal evaluation and make sure the module is operated under allowable temperature. Thermal curves shown in Figure 9 are based on different input voltages.

CAUTION: If you exceed these Derating guidelines, the converter may have an unplanned Over Temperature shut down. Also, these graphs are all collected near Sea Level altitude. Be sure to reduce the derating for higher altitude.

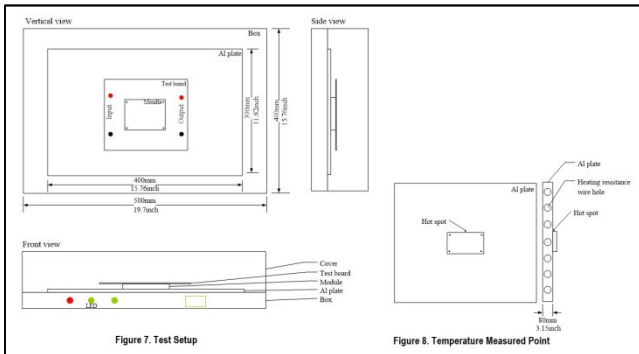

Figure 7. Test Setup

Figure 8. Temperature Measured Point

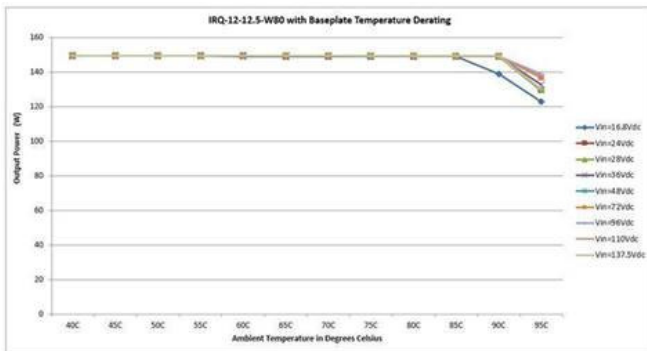

Figure 9. Derating Curves

Output Fusing

The converter is extensively protected against current, voltage and temperature extremes. However your output application circuit may need additional protection. In the extremely unlikely event of output circuit failure, excessive voltage could be applied to your circuit. Consider using an appropriate fuse in series with the output.

www.murata-ps.com/support

Output Current Limiting

The modules include an internal output over-current protection circuit, which endure current limiting for an unlimited duration during output overload. If the output current exceeds the OCP set point, the module will shut down, and always try to restart (hiccup mode) until the over current condition is corrected.

Output Short Circuit Condition

When a converter is in current-limit mode, the output voltage will drop as the output current demand increases. If the output voltage drops too low (approximately 97% of nominal output voltage for most models), the PWM controller will shut down. Following a time-out period, the PWM will restart, causing the output voltage to begin rising to its appropriate value. If the short-circuit condition persists, another shutdown cycle will initiate. This rapid on/off cycling is called "hiccup mode." The hiccup cycling reduces the average output current, thereby preventing excessive internal temperatures and/ or component damage.

The "hiccup" system differs from older latching short circuit systems because you do not have to power down the converter to make it restart. The system will automatically restore operation as soon as the short circuit condition is removed.

Output Capacitive Load

These converters do not require external capacitance added to achieve rated specifications. Users should only consider adding capacitance to reduce switching noise and/or to handle spike current load steps. Install only enough capacitance to achieve noise objectives. Excess external capacitance may cause degraded transient response and possible oscillation or instability.

NOTICE: Please use only this customer data sheet as product documentation when laying out your printed circuit boards and applying this product into your application. Do NOT use other materials as official documentation such as advertisements, product announcements, or website graphics.

We strive to have all technical data in this customer data sheet highly accurate and complete. This customer data sheet is revision-controlled and dated. The latest customer data sheet revision is normally on our website (www.murata-ps.com) for products which are fully released to Manufacturing. Please be especially careful using any data sheets labeled "Preliminary" since data may change without notice.

Remote Sense Input

Use the Sense inputs with caution. Sense is normally connected at the load. Sense inputs compensate for output voltage inaccuracy delivered at the load. This is done by correcting IR voltage drops along the output wiring and the current carrying capacity of PC board etch. This output drop (the difference between Sense and Vout when measured at the converter) should not exceed 0.5V. Consider using heavier wire if this drop is excessive. Sense inputs also improve the stability of the converter and load system by optimizing the control loop phase margin.

NOTE: The Sense input and power Vout lines are internally connected through low value resistors to their respective polarities so that the converter can operate without external connection to the Sense. Nevertheless, if the Sense function is not used for remote regulation, the user should connect +Sense to +Vout and -Sense to -Vout at the converter pins.

The remote Sense lines carry very little current. They are also capacitively coupled to the output lines and therefore are in the feedback control loop to regulate and stabilize the output. As such, they are not low impedance inputs and must be treated with care in PC board layouts. Sense lines on the PCB should run adjacent to DC signals, preferably Ground. In cables and discrete wiring, use twisted pair, shielded tubing or similar techniques.

Any long, distributed wiring and/or significant inductance introduced into the Sense control loop can adversely affect overall system stability. If in doubt, test your applications by observing the converter's output transient response during step loads. There should not be any appreciable ringing or oscillation. You may also adjust the output trim slightly to compensate for voltage loss in any external filter elements. Do not exceed maximum power ratings.

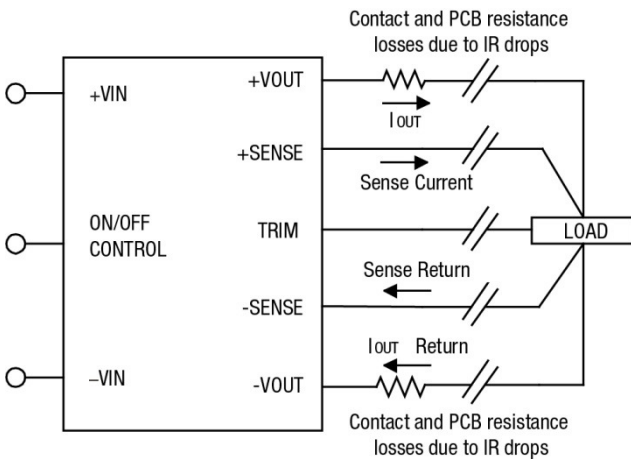

Figure 10. Remote Sense Circuit Configuration

NOTE: Please observe Sense inputs tolerance to avoid improper operation: The value of the Output Sense Range depends on the Output voltage, which decreases as the increases of the output voltage.

Output overvoltage protection is monitored at the output voltage pin, not the Sense pin. Therefore excessive voltage differences between Vout and Sense together with trim adjustment of the output can cause the overvoltage protection circuit to activate and shut down the output.

Power derating of the converter is based on the combination of maximum output current and the highest output voltage. Therefore the designer must insure:

$$(V_{out \text{ at pins}}) \times (I_{out}) \leq (\text{Max. rated output power})$$

$$[V_{out(+)} - V_{out(-)}] - [S_{ense(+)} - S_{ense(-)}] \leq \text{Output Sense Range}$$

Vo	12V	24V	54V
Output Sense Range	10%	5%	4%

Trimming the Output Voltage

The Trim input to the converter allows the user to adjust the output voltage over the rated trim range (please refer to the Specifications). In the trim equations and circuit diagrams that follow, trim adjustments use either a trimpot or a single fixed resistor connected between the Trim input and either the +Sense or -Sense terminals. Trimming resistors should have a low temperature coefficient (± 100 ppm/deg.C or less) and be mounted close to the converter. Keep leads short. If the trim function is not used, leave the trim unconnected. With no trim, the converter will exhibit its specified output voltage accuracy.

There are two CAUTIONs to observe for the Trim input:

CAUTION: To avoid unplanned power down cycles, do not exceed EITHER the maximum output voltage OR the maximum output power when setting the trim. Be particularly careful with a trimpot. If the output voltage is excessive, the OVP circuit may inadvertently shut down the converter. If the maximum power is exceeded, the converter may enter current limiting. If the power is exceeded for an extended period, the converter may overheat and encounter overtemperature shut down.

CAUTION: Be careful of external electrical noise. The Trim input is a sensitive input to the converter's feedback control loop. Excessive electrical noise may cause instability or oscillation. Keep external connections short to the Trim input. Use shielding if needed.

Trim Equations

Trim Down: Connect trim resistor between trim pin and -Sense When Vnom=12V

$$R_{Trimdn} (k\Omega) = 1 * \frac{V_{nom}}{V_{nom} - V_o} - 2$$

When Vnom=24V

$$R_{Trimdn} (k\Omega) = 10 * \frac{V_{nom}}{V_{nom} - V_o} - 20$$

Trim Up: Connect trim resistor between trim pin and +Sense When Vnom=12V

$$R_{Trimup} (k\Omega) = \frac{1 * V_{nom} * (1 + \frac{V_o - V_{nom}}{V_{nom}})}{1.225 * \frac{V_o - V_{nom}}{V_{nom}}} - 1 * \frac{V_{nom}}{V_o - V_{nom}} - 2$$

When Vnom=24V

$$R_{Trimup} (k\Omega) = \frac{10 * V_{nom} * (1 + \frac{V_o - V_{nom}}{V_{nom}})}{1.225 * \frac{V_o - V_{nom}}{V_{nom}}} - 10 * \frac{V_{nom}}{V_o - V_{nom}} - 20$$

When Vnom=12V

Output Voltage	10.8V	11.4V	12.6V	13.2V
Rtrim up(kΩ)	NA	NA	390.89	204.27
Rtrim down(kΩ)	8	18	NA	NA

When $V_{nom}=24V$

Output Voltage	21.6V	22.8V	25.2V	26.4V
Rtrim up(kΩ)	NA	NA	3908.86	2042.74
Rtrim down(kΩ)	80	180	NA	NA

Do not exceed the specified trim range or maximum power ratings when adjusting trim. Use 1% precision resistors mounted close to the converter on short leads.

If sense is not installed, connect the trim resistor to the respective Vout pin.

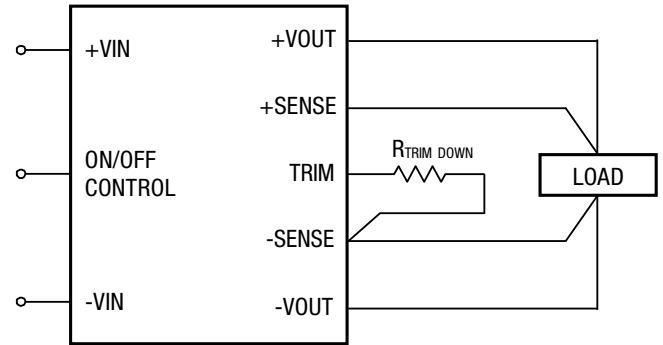

Figure 13. Trim Connections to Decrease Output Voltage

Trim Circuits

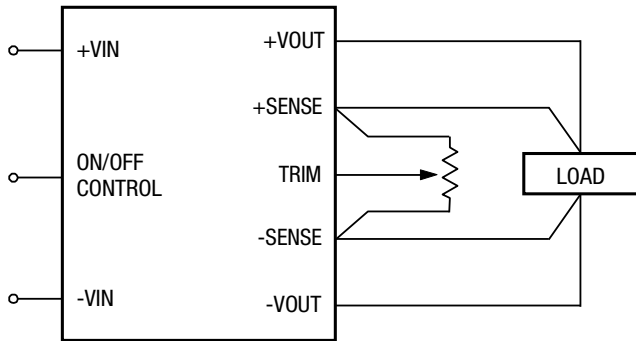

Figure 11. Trim Connections Using a Trimpot

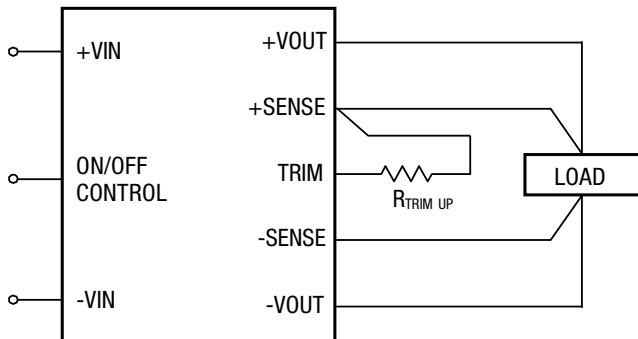

Figure 12. Trim Connections to Increase Output Voltages

Through-hole Soldering Guidelines

Murata Power Solutions recommends the TH soldering specifications below when installing these converters. These specifications vary depending on the solder type. Exceeding these specifications may cause damage to the product. Your production environment may differ; therefore please thoroughly review these guidelines with your process engineers.

Wave Solder Operations for Through-Hole mounted products (THMT)

<u>For Sn/Ag/Cu based solders:</u>	
Maximum Preheat Temperature	115° C.
Maximum Pot Temperature	270° C.
Maximum Solder Dwell Time	7 seconds
<u>For Sn/Pb based solders:</u>	
Maximum Preheat Temperature	105° C.
Maximum Pot Temperature	250° C.
Maximum Solder Dwell Time	6 seconds

Murata Power Solutions, Inc.
129 Flanders Rd., Westborough, MA 01581 USA
ISO 9001 and 14001 REGISTERED



This product is subject to the following **operating requirements** and the **Life and Safety Critical Application Sales Policy**:
Refer to: <http://www.murata-ps.com/requirements/>

Murata Power Solutions, Inc. makes no representation that the use of its products in the circuits described herein, or the use of other technical information contained herein, will not infringe upon existing or future patent rights. The descriptions contained herein do not imply the granting of licenses to make, use, or sell equipment constructed in accordance therewith. Specifications are subject to change without notice.
© 2020 Murata Power Solutions, Inc.

X-ON Electronics

Largest Supplier of Electrical and Electronic Components

Click to view similar products for [Isolated DC/DC Converters](#) category:

Click to view products by [Murata](#) manufacturer:

Other Similar products are found below :

[ESM6D044440C05AAQ](#) [MI-220-IW](#) [MI-J22-IY](#) [FMD15.24G](#) [PSL486-7LR](#) [PSR152.5-7IR](#) [Q48T30020-NBB0](#) [AVO240-48S12B-6L](#)
[AVO250-48S28B-6L](#) [NAN-0505](#) [HW-L16D](#) [JAHW100Y1](#) [217-1617-001](#) [22827](#) [SPB05C-12](#) [SQ24S15033-PS0S](#) [18952](#) [19-130041](#) [CE-](#)
[1003](#) [CE-1004](#) [GQ2541-7R](#) [PSE1000DCDC-12V](#) [RDS180245](#) [MAU228](#) [419-2065-201](#) [449-2075-101](#) [J80-0041NL](#) [V24C12M100BL](#)
[V24C5C100BL2](#) [V300C12C150BG](#) [V375C24E150BG](#) [VE-JW3-CY](#) [VI-241-EU](#) [419-2062-200](#) [419-2063-401](#) [419-2067-101](#) [419-2067-501](#)
[419-2068-001](#) [DCG40-5G](#) [DFC15U48D15](#) [449-2067-000](#) [XGS-0512](#) [XGS-1205](#) [XGS-1212](#) [XGS-2412](#) [XGS-2415](#) [XKS-1215](#) [033456](#)
[NCT1000N040R050B](#) [SPB05B-15](#)