

DESCRIPTION

HR1001A is the OCP auto-recovery version of HR1001B.

HR1001A is an enhanced LLC controller, which provides new features of adaptive dead-time adjustment (ADTA) and capacitive mode protection (CMP).

The adaptive dead-time adjustment inserts a dead time between the two complimentary gate outputs automatically. This is ensured by keeping the outputs off while sensing the dv/dt current of the half-bridge switching node. The ADTA features easier design, lower EMI, and higher efficiency.

HR1001A incorporates anti-capacitive mode protection, which prevents potentially destructive capacitive mode switching if the output is shorted or has a severe overload. This feature protects the MOSFET during abnormal conditions, making the converter robust.

HR1001A has a programmable oscillator that sets both the maximum and minimum switching frequencies. It starts up at a programmed maximum switching frequency and decays until the control loop takes over to prevent excessive inrush current.

HR1001A enters a controlled burst mode at light load to minimize the power consumption and tighten output regulation.

HR1001A provides rich protection features, including two-level OCP, auto—recovery, external latch shutdown, brown in/out, CMP, and OTP, improving converter design safety with minimal extra components.

FEATURES

- Two-Level Over-Current Protection: Frequency Shift and Auto-Recovery Mode with Programmable Duration Time
- Adaptive Dead-Time Adjustment
- Capacitive Mode Protection
- 50% Duty Cycle, Variable Frequency Control for Resonant Half-Bridge Converter
- 600V High-Side Gate Driver with Integrated Bootstrap Diode with High dv/dt Immunity High-Accuracy Oscillator
- Operates up to 600kHz
- Latched Disable Input for Easy Protection
- Remote On/Off Control and Brown-Out Protection through BO
- Programmable Burst Mode Operation at Light Load
- Non-Linear Soft Start for Monotonic Output Voltage Rise
- SOIC-16 Package

APPLICATIONS

- LCD and PDP TVs
- Desktop PCs and Servers
- Telecom SMPS
- AC/DC Adapter, Open-Frame SMPS
- Video Game Consoles
- Electronic Lighting Ballast

All MPS parts are lead-free, halogen-free, and adhere to the RoS directive. For MPS green status, please visit the MPS website under Quality Assurance. "MPS" and "The Future of Analog IC Technology" are registered trademarks of Monolithic Power Systems, Inc.

TYPICAL APPLICATION

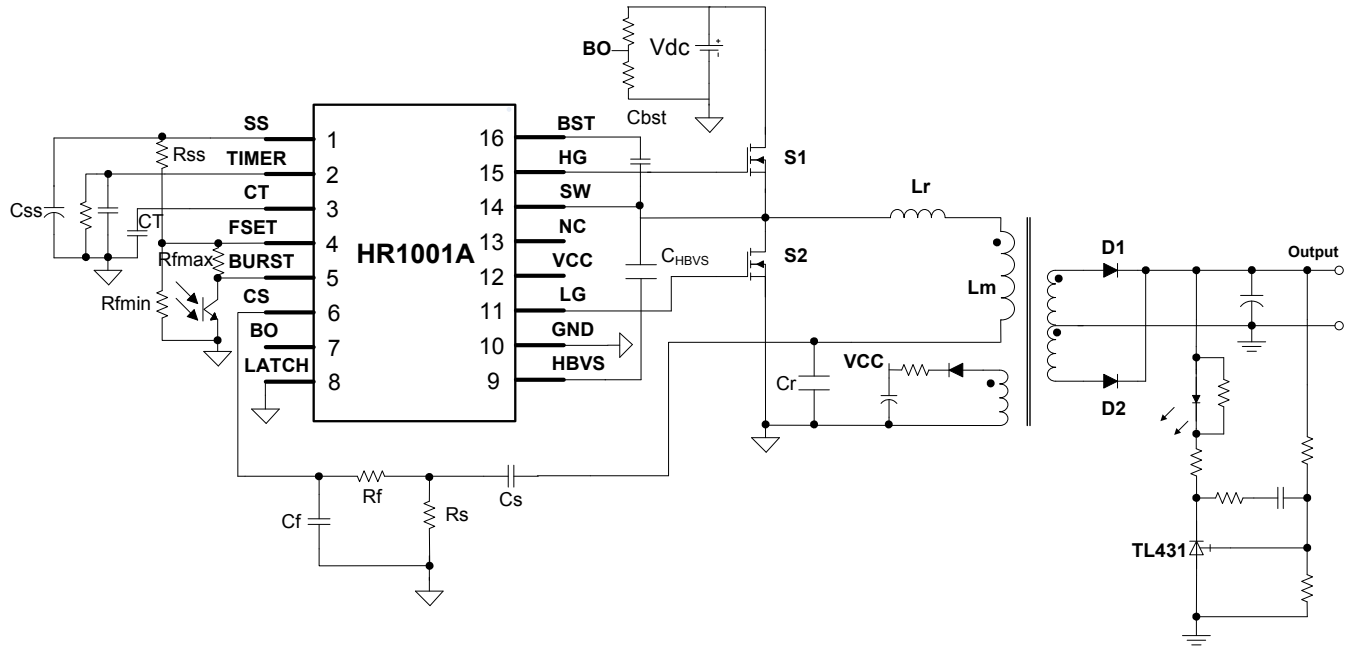

ORDERING INFORMATION

| Part Number* | Package | Top Marking |
|--------------|---------|-------------|
| HR1001AGS | SOIC-16 | See Below |

* For Tape & Reel, add suffix -Z (e.g. HR1001AGS-Z)

TOP MARKING

MPSYYWW
HR1001A
LLLLLLLLL

MPS: MPS prefix
 YY: Year code
 WW: Week code
 HR1001A: Part number
 LLLLLLLLL: Lot number

PACKAGE REFERENCE

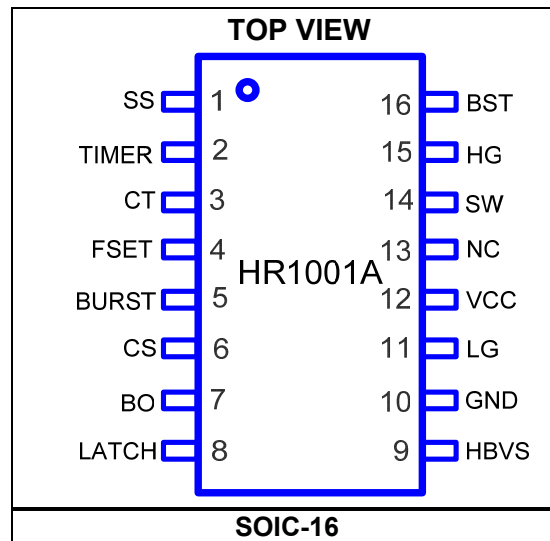

ABSOLUTE MAXIMUM RATINGS ⁽¹⁾

BST voltage.....-0.3V to 618V
 SW voltage-3V to 600V
 Max. voltage slew rate of SW..... 50V/ns
 Supply voltage (V_{CC})..... Self limited
 Sink current of HBVS..... ± 65 mA
 Voltage on HBVS..... -0.3V to Self limited
 Source current of FSET..... 2mA
 Voltage rating of LG..... -0.3V to V_{CC}
 Voltage on CS..... -3V to 6V
 Other analog inputs and outputs.....-0.3V to 6V
 Continuous power dissipation ($T_A = +25^\circ\text{C}$) ⁽²⁾
 P_{IC} 1.56W
 Junction temperature..... 150°C
 Lead temperature 260°C
 Storage temperature..... -65°C to $+150^\circ\text{C}$
 ESD immunity:
 BST, HG, SW passes HBM 2.5kV,
 other pins can pass HBM 4kV.

Recommended Operating Conditions ⁽³⁾

Supply voltage V_{CC} 13V to 15.5V
 Analog inputs and outputs-0.3V to 6V
 Operating junction temp (T_J)..... -40°C to $+125^\circ\text{C}$

| Thermal Resistance ⁽⁴⁾ | | θ_{JA} | θ_{JC} |
|--|--|---------------|-----------------------------|
| SOIC-16 | | 80..... | 35 $^\circ\text{C/W}$ |

Notes:

- 1) Exceeding these ratings may damage the device.
- 2) The maximum allowable power dissipation is a function of the maximum junction temperature T_J (MAX), the junction-to-ambient thermal resistance θ_{JA} , and the ambient temperature T_A . The maximum allowable continuous power dissipation at any ambient temperature is calculated by P_D (MAX) = $(T_J$ (MAX)- T_A)/ θ_{JA} . Exceeding the maximum allowable power dissipation produces an excessive die temperature, causing the regulator to go into thermal shutdown. Internal thermal shutdown circuitry protects the device from permanent damage.
- 3) The device is not guaranteed to function outside of its operating conditions.
- 4) Measured on a JESD51-7, 4-layer PCB.

ELECTRICAL CHARACTERISTICS

VCC=13V, C_{HG}=C_{LG}=1nF, CT=470pF, R_{FSET}=12kΩ, T_J=-40°C ~ 125°C, min & max are guaranteed by characterization, typical is tested under 25°C, unless otherwise specified.

| Parameter | Symbol | Condition | Min | Typ | Max | Units |
|--|-----------------------|---|------|------|------|-------|
| IC Supply Voltage (VCC) | | | | | | |
| VCC operating range | | | 8.9 | | 15.5 | V |
| VCC high threshold, IC switch on | V _{CCH} | | 10.3 | 11 | 11.7 | V |
| VCC low threshold, IC switch off | V _{CCL} | | 7.5 | 8.2 | 8.9 | V |
| Hysteresis | V _{CC-hys} | | | 2.8 | | V |
| VCC clamp voltage | V _{CC-Clamp} | I _{Clamp} = 1mA | | 16.5 | | V |
| IC Supply Current (VCC) | | | | | | |
| Start-up current | I _{start-up} | Before the device turns on, VCC=V _{CCH} -0.2V | | 250 | 320 | μA |
| Quiescent current | I _q | Device on, V _{Burst} <1.23V, R _{FSET} = 12k, (Fmin=60kHz) | | 1.2 | 1.5 | mA |
| | I _{q-f} | Device on V _{Burst} <1.23V R _{FSET} =3.57k, (Fburst=200kHz) | | 1.42 | 1.8 | mA |
| Operating current | I _{CC-nor} | Device on V _{Burst} =V _{FSET} | | 3 | 5 | mA |
| Residual consumption | I _{Fault} | VCC<8.2V or V _{LATCH} >1.85V or V _{CS} >1.5V or V _{TIMER} >3.5V or V _{BO} <1.81V or V _{BO} >5.5V or OTP. | 240 | 350 | 420 | μA |
| High-Side Floating Gate Driver Supply (BST, SW) | | | | | | |
| BST leakage current | I _{LK-BST} | V _{BST} =600V, T _J =25°C | | | 12 | μA |
| SW leakage current | I _{LK-SW} | V _{SW} =582V, T _J =25°C | | | 12 | μA |
| Current Sensing (CS) | | | | | | |
| Input bias current | I _{CS} | V _{CS} =0 to V _{CSlatch} | | | 2 | μA |
| Frequency shift threshold | V _{CS-OCR} | | 0.71 | 0.78 | 0.85 | V |
| OCP threshold | V _{CS-OCP} | | 1.41 | 1.5 | 1.59 | V |
| Current polarity comparator ref. when HG turns off | V _{CSPR} | | 50 | 85 | 131 | mV |
| Current polarity comparator ref. when LG turns off | V _{CSNR} | | -131 | -85 | -50 | mV |
| Line Voltage Sensing (BO) | | | | | | |
| Start-up threshold voltage | V _{BO-On} | | | 2.30 | 2.4 | V |
| Turn-off threshold voltage | V _{BO-Off} | | 1.72 | 1.81 | | V |
| Clamp level | V _{BO-Clamp} | | 5.1 | 5.5 | 5.9 | V |

ELECTRICAL CHARACTERISTICS (continued)

VCC=13V, C_{HG}=C_{LG}=1nF, CT=470pF, R_{FSET}=12kΩ, T_J=-40°C ~ 125°C, min & max are guaranteed by characterization, typical is tested under 25°C, unless otherwise specified.

| Parameter | Symbol | Condition | Min | Typ | Max | Units |
|--|-------------------------|--|------|------|------|-------|
| Latch Function (LATCH) | | | | | | |
| Input bias current (V _{LATCH} =0 to V _{th}) | I _{LATCH} | | | | 1 | μA |
| LATCH threshold | V _{LATCH} | | 1.72 | 1.85 | 1.95 | V |
| Oscillator | | | | | | |
| Output duty cycle | D | T _J =25°C | 48 | 50 | 52 | % |
| | | T _J =-40 ~ 125°C | 47 | 50 | 53 | % |
| Oscillation frequency | f _{osc} | CT≤150pF, R _{FSET} ≤ 2k | | | 600 | kHz |
| CT peak value | V _{CFp} | | | 3.8 | | V |
| CT valley value | V _{CFv} | | | 0.9 | | V |
| Voltage reference at FSET | V _{REF} | | 1.87 | 2 | 2.05 | V |
| Dead-time | t _{DMIN} | C _{HBVS} =5pF, typically | 180 | 235 | 290 | ns |
| | t _{DMAX} | | | 1 | | μs |
| | t _{D-float} | HBVS floating | 250 | 350 | 450 | ns |
| Timer for CMP | t _{CMP} | | | 52 | | μs |
| Half-Bridge Voltage Sense (HBVS) | | | | | | |
| Voltage clamp | V _{HBVS-Clamp} | | | 7.6 | | V |
| Minimum voltage change rate can be detected | dv _{min} /dt | C _{HBVS} =5pF, typically | | | 180 | V/μs |
| Turn-on delay | T _d | Slope finish to turn-on delay | | 100 | | ns |
| Soft-Start Function (SS) | | | | | | |
| Discharge resistance | R _d | V _{CS} > V _{CS-OCR} | | 130 | | Ω |
| Standby Function (BURST) | | | | | | |
| Disable threshold | V _{Burst} | | 1.17 | 1.23 | 1.28 | V |
| Hysteresis | V _{Burst-hys} | | | 30 | 100 | mV |
| Delayed Shutdown (TIMER) | | | | | | |
| Charge current | I _{TIMER} | V _{TIMER} =1V, V _{CS} =0.85V, T _J =25°C | 80 | 130 | 180 | μA |
| Threshold for forced operation at maximum frequency | V _{TIMER-fmax} | | 1.80 | 2 | 2.10 | V |
| Shutdown threshold | V _{TIMER-SD} | | 3.2 | 3.5 | 3.7 | V |
| Restart threshold | V _{TIMER-R} | | 0.21 | 0.28 | 0.35 | V |
| Low-Side Gate Driver (LG, Referenced to GND) | | | | | | |
| Peak source current ⁽⁵⁾ | I _{sourcepk} | | | 0.75 | | A |
| Peak sink current ⁽⁵⁾ | I _{sinkpk} | | | 0.87 | | A |
| Sourcing resistor | R _{source} | LG_R@Isrc=0.1 A | | 4 | | Ω |
| Sinking resistor | R _{sink} | LG_R@Isnk=0.1 A | | 2 | | Ω |
| Fall time | t _f | | | 30 | | ns |

ELECTRICAL CHARACTERISTICS (continued)

VCC=13V, C_{HG}=C_{LG}=1nF, C_T=470pF, R_{FSET}=12kΩ, T_J=-40°C ~ 125°C, min & max are guaranteed by characterization, typical is tested under 25°C, unless otherwise specified.

| Parameter | Symbol | Condition | Min | Typ | Max | Units |
|---|---------------------------|---|-----|------|-----|-------|
| Rise time | t _{LG-r} | | | 30 | | ns |
| UVLO saturation | | VCC=0 to VCC _H , I _{sink} =2mA | | | 1 | V |
| High-Side Gate Driver (HG, Referenced to SW) | | | | | | |
| Peak source current ⁽⁵⁾ | I _{HG-source-pk} | | | 0.74 | | A |
| Peak sink current ⁽⁵⁾ | I _{HG-sink-pk} | | | 0.87 | | A |
| Sourcing resistor | R _{HG-source} | HG_R@Isrc=0.01 A | | 4 | | Ω |
| Sinking resistor | R _{HG-sink} | HG_R@Isnk=0.01 A | | 2 | | Ω |
| Fall time | t _{HG-f} | | | 30 | | ns |
| Rise time | t _{HG-r} | | | 30 | | ns |
| Thermal Shutdown | | | | | | |
| Thermal shutdown threshold ⁽⁵⁾ | | | | 150 | | °C |
| Thermal shutdown recovery threshold ⁽⁵⁾ | | | | 120 | | °C |

NOTE:

5). Guaranteed by design.

TYPICAL PERFORMANCE CHARACTERISTICS (continued)

Performance waveforms are generated using the evaluation board built with the design example on page 22, $V_{AC}=120V$, $V_{out}=24V$, $I_{out}=4.16A$, $T_A=25^{\circ}C$, unless otherwise noted.

Efficiency

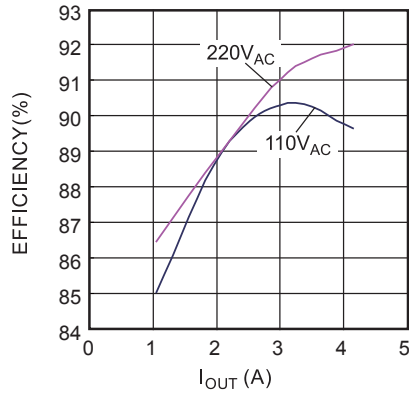

Steady State

$V_{OUT}=24V$, $I_{OUT}=4.16A$

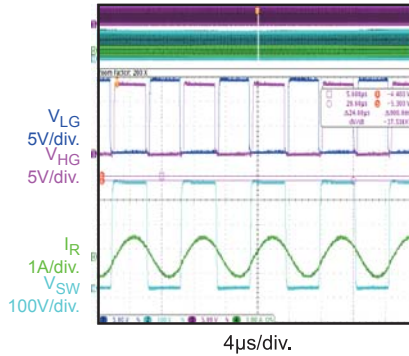

Steady State

$V_{OUT}=24V$, $I_{OUT}=0A$

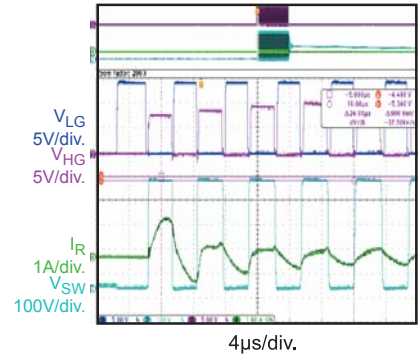

Steady State

$V_{OUT}=24V$, $I_{OUT}=4.16A$

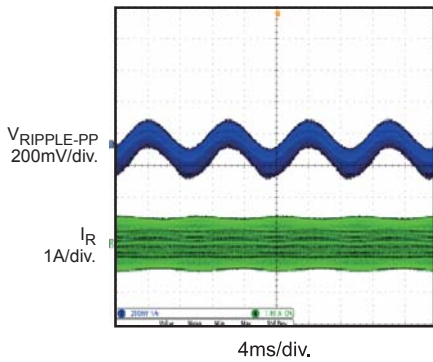

Steady State

$V_{OUT}=24V$, $I_{OUT}=0A$

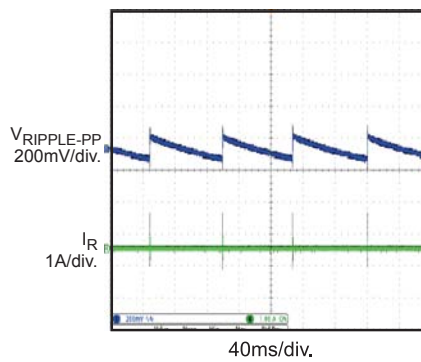

Start-Up

$V_{OUT}=24V$, $I_{OUT}=4.16A$

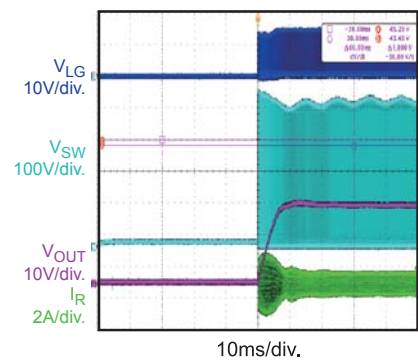

Start-Up

$V_{OUT}=24V$, $I_{OUT}=0A$

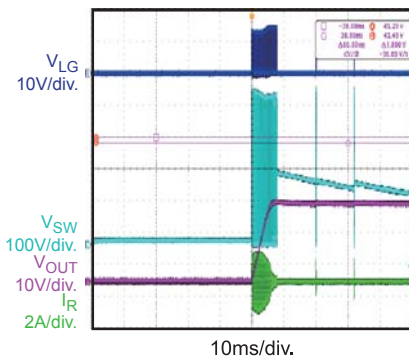

Shutdown

$V_{OUT}=24V$, $I_{OUT}=4.16A$

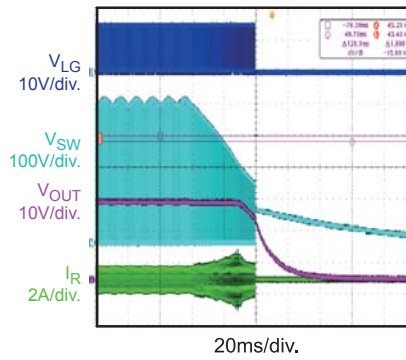

Capacitive-Mode Protection

V_{OUT} Short

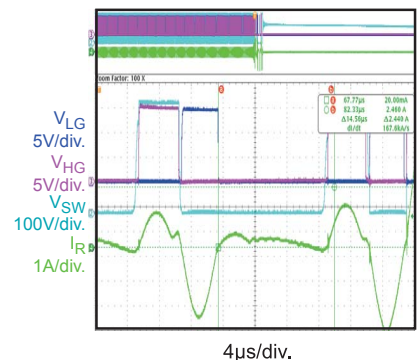

TYPICAL PERFORMANCE CHARACTERISTICS (continued)

Performance waveforms are generated using the evaluation board built with the design example on page 22, $V_{AC}=120V$, $V_{out}=24V$, $I_{out}=4.16A$, $T_A=25^{\circ}C$, unless otherwise noted.

Transient

0A to 4.16A

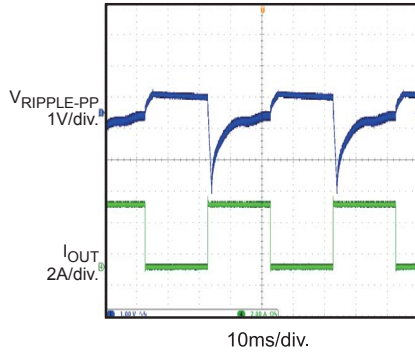

Transient

2.08A to 4.16A

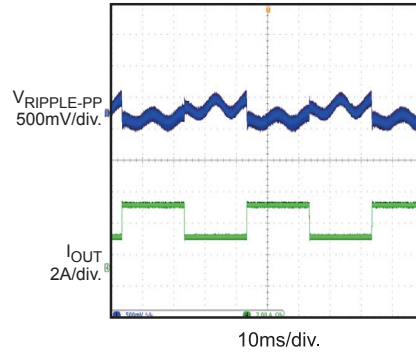

Short Circuit Protection Entry

$V_{CS} > 1.5V$, Hiccup and Auto-Recovery

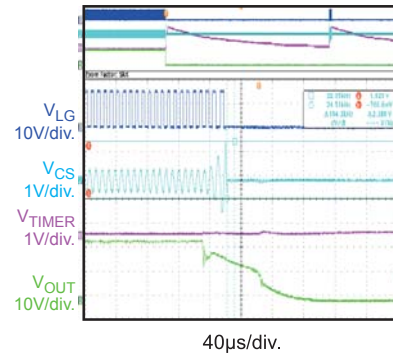

Over-Current Protection Entry

$0.8V < V_{CS} < 1.5V$, Hiccup and Auto-Recovery

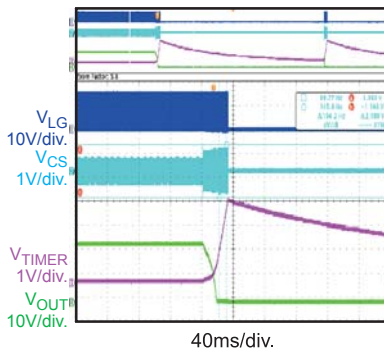

OCP or SCP Recovery

$V_{CS} > 0.8V$, Hiccup and Auto-Recovery

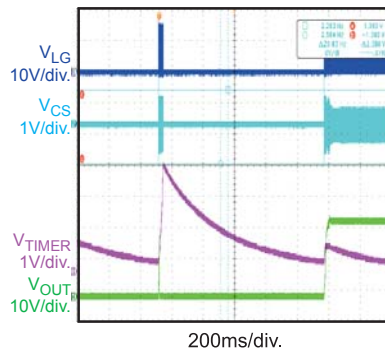

Dead Time

when HG Turns Off

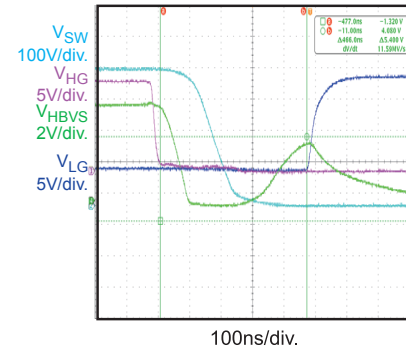

Delay Time
when HG Turns Off

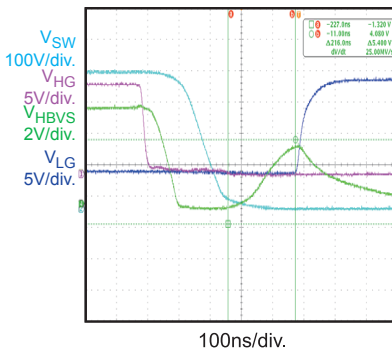

Dead Time
when LG Turns Off

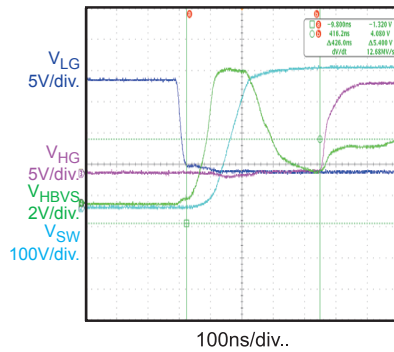

Delay Time
when LG Turns Off

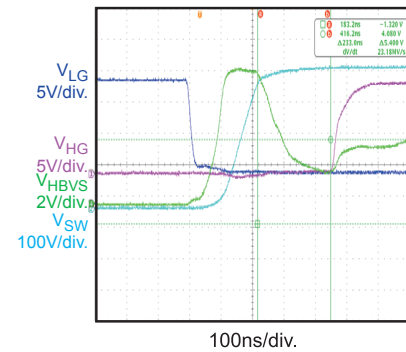

PIN FUNCTIONS

| Pin # | Name | Description |
|-------|-------|---|
| 1 | SS | Soft-start. Connect an external capacitor from SS to GND and a resistor to FSET to set the maximum oscillator frequency and the time constant for the frequency shift during start-up. An internal switch discharges the capacitor when the chip turns off ($V_{CC} < UVLO$, $BO < 1.81V$ or $> 5.5V$, $LATCH > 1.85V$, $CS > 1.5V$, $TIMER > 2V$, thermal shutdown) to guarantee soft-start. |
| 2 | TIMER | Period between over-current and shutdown. Connect a capacitor and a resistor from TIMER to GND to set both the maximum duration from an over-current condition before the IC stops switching, and the delay before the IC resumes switching. Each time the voltage on CS exceeds 0.78V, an internal 130 μ A source charges the capacitor; an external resistor discharges this capacitor slowly. If the voltage on TIMER reaches 2V, the soft-start capacitor discharges completely, raising its switching frequency to its maximum value. The 130 μ A source remains on. When the voltage exceeds 3.5V, the IC stops switching and the internal current source turns off, then the voltage decays. The IC enters soft start when the voltage drops below 0.28V. This converter works intermittently with very low average input power under short-circuit conditions. |
| 3 | CT | Time set. An internal current source programmed by an external network connected to FSET charges and discharges a capacitor connected to GND. This determines the converter's switching frequency. |
| 4 | FSET | Switching frequency set. FSET provides a precise 2V reference. A resistor connected from FSET to GND defines a current that sets the minimum oscillator frequency. Connect the phototransistor of an optocoupler to FSET through a resistor to close the feedback loop that modulates the oscillator frequency. It regulates the converter's output voltage. The value of this resistor sets the maximum operating frequency. An R-C series connected from FSET to GND sets the frequency shift at start-up to prevent excessive inrush energy. |
| 5 | BURST | Burst mode operation threshold. BURST senses the voltage related to the feedback control, which is compared to an internal reference (1.23V). When the voltage on BURST is lower than this reference, the IC enters an idle state and reduces its quiescent current. When the feedback drives BURST above 1.26V (30mV hysteresis), the chip resumes switching. A soft start is not invoked. This function enables burst mode operation when the load falls below a programmed level, determined by connecting an appropriate resistor to the optocoupler to FSET (see Functional Block Diagram). Connect BURST to FSET if burst mode is not used. |
| 6 | CS | Current sense of half-bridge. CS uses a sense resistor or a capacitive divider to sense the primary current. CS has the following functions: <ul style="list-style-type: none"> • Over-current regulation: As the voltage exceeds a 0.78V threshold, the soft-start capacitor on SS discharges internally. The frequency increases, limiting the power throughput. Under an output short circuit, this normally results in a nearly constant peak primary current. TIMER limits the duration of this condition. • Over-current protection: If the current continues to build despite the frequency increase, when $V_{cs} > 1.5V$, the IC stops switching immediately and TIMER continues to be charged. Once the voltage on TIMER exceeds 3.5V, the IC turns off the internal charge current and the voltage on TIMER decays. The IC re-enters soft start when the voltage falls below 0.28V. This is the auto-recovery operation in an over-current condition. • Capacitive mode protection: The moment LG turns off, CS is compared to the V_{CSNR} CMP threshold. If $V_{cs} > V_{CSNR}$, it blocks the HG gate turning on until the slope is detected, or the CMP timer is complete. The moment HG turns off, CS is compared to the V_{CSPR} CMP threshold. If $V_{cs} < V_{CSPR}$, it blocks the low-side gate turning on until the slope is detected, or the CMP timer is complete. If a capacitive mode status is detected, SS is not discharged immediately; there is a 1μs delay. After the blanking delay, SS is discharged if the fault condition in capacitive mode remains. It avoids the influence of CS noise effectively. Connect CS to GND if the function is not used. |

PIN FUNCTIONS *(continued)*

| Pin # | Name | Description |
|-------|-------|---|
| 7 | BO | Input voltage sense and brown in/out protection. If the voltage on BO is over 2.3V, the IC enables the gate driver. If the voltage on BO is below 1.81V, the IC is disabled. |
| 8 | LATCH | IC latch off. When the voltage on LATCH exceeds 1.85V, the IC shuts down and lowers its bias current to its near pre-startup level. LATCH is reset when the voltage on VCC is discharged below its UVLO threshold. Connect LATCH to GND if the function is not used. |
| 9 | HBVS | Half-bridge dv/dt sense. In order to detect the dv/dt of the half-bridge, a high-voltage capacitor is connected between SW and HBVS. The dv/dt current through HBVS is used to adjust the dead-time adaptively between the high-side gate and the low-side gate. |
| 10 | GND | Ground. Current return for both the low-side gate-driver and the IC bias. Connect all external ground connections with a trace to GND, one for signals and a second for pulsed current return. |
| 11 | LG | Low-side gate driver output. The driver is capable of a 0.8A source/sink peak current to drive the lower MOSFET of the half-bridge. LG is pulled to GND during UVLO. |
| 12 | VCC | Supply voltage. VCC supplies both the IC bias and the low-side gate driver. A small bypass capacitor (e.g., 0.1µF) is helpful to get a clean bias voltage for the IC signal. |
| 13 | NC | High-voltage spacer. No internal connection. It isolates the high-voltage pin and eases compliance with safety regulations (creepage-distance) on the PCB. |
| 14 | SW | High-side switch source. Current return for the high-side gate drive current. SW requires careful layout to avoid large spikes below ground. |
| 15 | HG | High-side floating gate driver output. HG is capable of a 0.8A source/sink peak current to drive the upper MOSFET of the half-bridge. An internal resistor connected to SW ensures that HG does not float during UVLO. |
| 16 | BST | Bias for floating voltage supply of high-side gate driver. Connect a bootstrap capacitor between BST and SW. This capacitor is charged by an internal bootstrap diode driven in-phase with the low-side gate drive. |

FUNCTIONAL BLOCK DIAGRAM

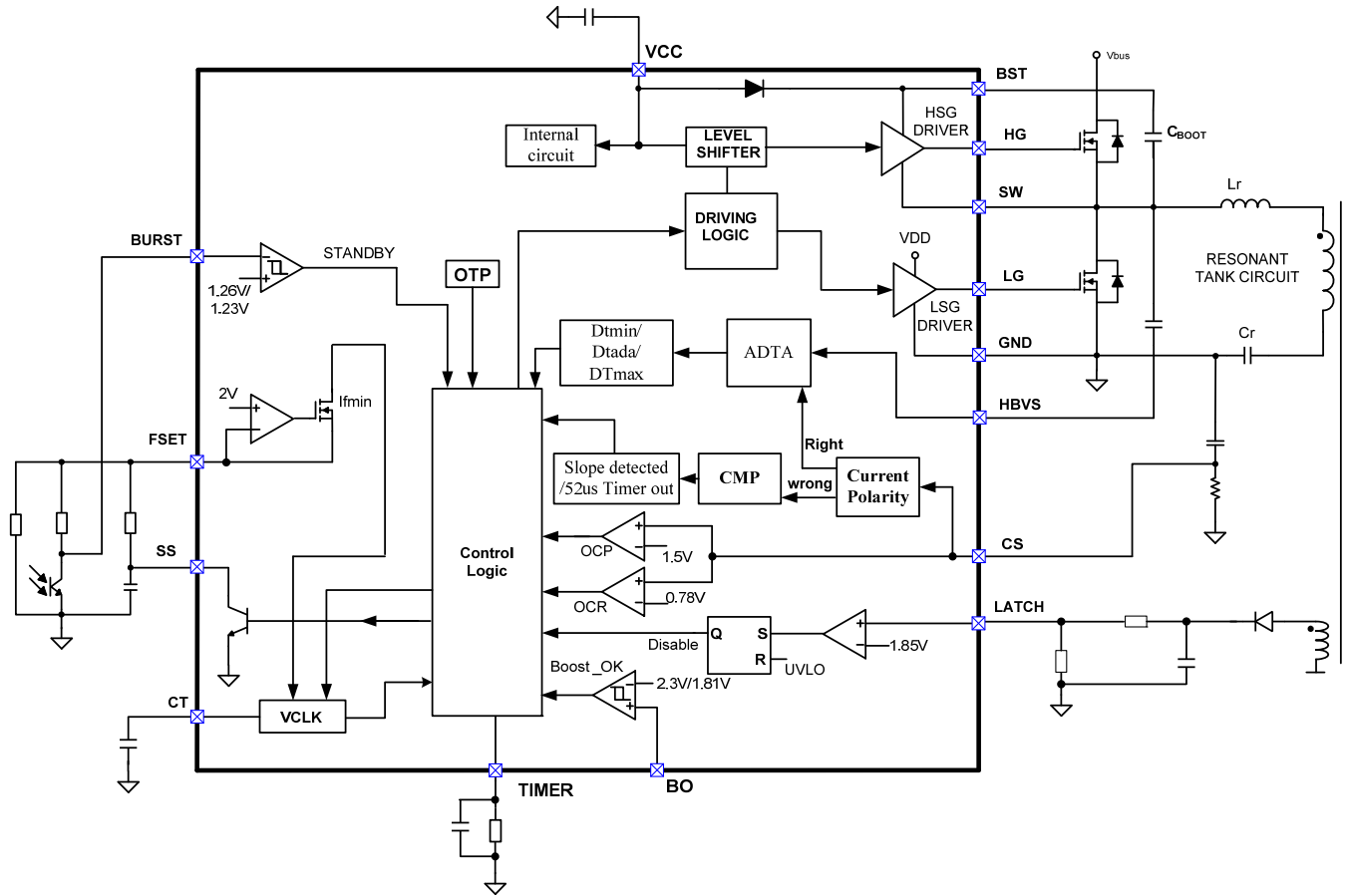

Figure 1: Functional Block Diagram

APPLICATION INFORMATION

Oscillator

Figure 2 shows the oscillator block diagram. A modulated current charges and discharges the CT capacitor repeatedly between its peak valley thresholds, which determines the oscillator frequency.

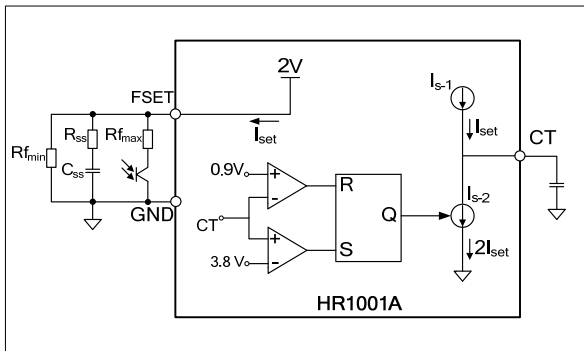

Figure 2: Oscillator Block Diagram

FSET sets the CT charging current, I_{s-1} . When CT passes its peak threshold (3.8V), the flip-flop is set and a discharge current source of twice the charge current is enabled. The difference between these two currents forces the charge and discharge of CT to be equal. When the voltage on the CT capacitor falls below its valley threshold (0.9 V), the flip-flop is reset and turns off I_{s-2} . This starts a new switching cycle. Figure 3 shows the detailed waveform of the oscillator.

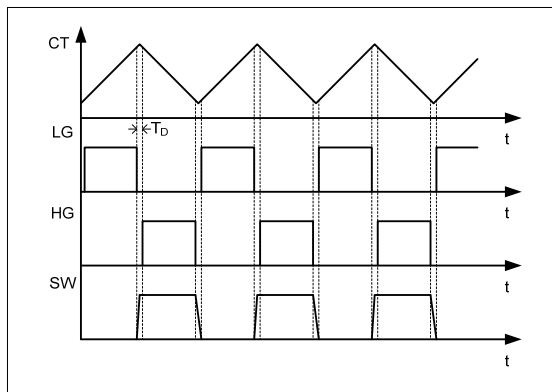

Figure 3: CT Waveform and Gate Signal

The RC network connected externally to FSET determines the normal switching frequency as well as the soft start switching frequency.

- $R_{f_{min}}$ from FSET to GND contributes the maximum resistance of the external RC network when the phototransistor does not conduct. This sets the FSET minimum source current, which defines the minimum switching frequency.
- Under normal operation, the phototransistor adjusts the current flow through $R_{f_{max}}$ to modulate the frequency for output voltage regulation. When the phototransistor is saturated, the current through $R_{f_{max}}$ is at its maximum as setting the frequency at its maximum).
- An RC in series connected between FSET and GND shifts the frequency at start-up. (Please see the “Soft-Start Operation” section for details.)

Equation (1) and Equation (2) are used to set the minimum and maximum frequency:

$$f_{min} = \frac{1}{3 \cdot CT \cdot R_{f_{min}}} \quad (1)$$

$$f_{max} = \frac{1}{3 \cdot CT \cdot (R_{f_{min}} \parallel R_{f_{max}})} \quad (2)$$

Typically, the CT capacitance is between 0.1nF and 1nF. Equation (3) and Equation (4) calculate the values of $R_{f_{min}}$ and $R_{f_{max}}$:

$$R_{f_{min}} = \frac{1}{3 \cdot CT \cdot f_{min}} \quad (3)$$

$$R_{f_{max}} = \frac{R_{f_{min}}}{\frac{f_{max}}{f_{min}} - 1} \quad (4)$$

It is recommended to use a CT capacitor ($\leq 330\text{pF}$) for best overall temperature performance.

Soft-Start Operation (SS)

For the resonant half-bridge converter, the power delivered is inversely proportional to its switching frequency. To ensure the converter starts or restarts with safe currents, the soft-start forces a high initial switching frequency until the value is controlled by the closed loop.

The soft start is achieved using an external RC series circuit, as shown in Figure 4.

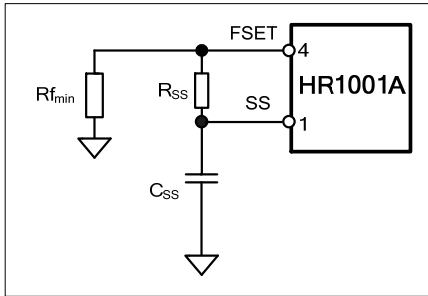

Figure 4: Soft-Start Block

When start-up begins, the SS voltage is 0V, the soft-start resistor (R_{SS}) is in parallel to $R_{f_{min}}$. $R_{f_{min}}$ and R_{SS} determine the initial frequency. Refer to Equation (5):

$$f_{start} = \frac{1}{3 \cdot CT \cdot (R_{f_{min}} || R_{SS})} \quad (5)$$

During start-up, C_{SS} charges until its voltage reaches the reference (2V) and the current through R_{SS} decays to zero. This period takes about $5 \times (R_{SS} \times C_{SS})$. During this period, the switching frequency change follows an exponential curve: initially, the C_{SS} charge reduces the frequency relatively quickly, but the rate decreases gradually.

After soft start period, the switching frequency is dominated by the feedback loop for regulating the output voltage.

With soft start, the current of resonant tank increases gradually during the start-up.

Use Equation (6) and Equation (7) to select the soft-start RC network:

$$R_{SS} = \frac{R_{f_{min}}}{\frac{f_{start}}{f_{min}} - 1} \quad (6)$$

$$C_{SS} = \frac{3 \cdot 10^{-3}}{R_{SS}} \quad (7)$$

Select an initial frequency (f_{start}) at least $4 \times f_{min}$. When selecting C_{SS} , there is a trade-off between the desired soft-start operation and the OCP speed (see the “Over-Current Protection” section for details).

Adaptive Dead-Time Adjustment (ADTA)

When operating in inductive mode, the soft switching of the power MOSFETs result in high efficiency of the resonant converter. A fixed dead time may result in hard switching at light load, especially when the magnetizing inductance (L_m) is too large. Too long of a dead time may lead to loss of ZVS, the current may change polarity during the dead time, then results in capacitive mode switching. The adaptive dead-time control adjusts the dead-time automatically by detecting the dv/dt of the half-bridge switching node (SW).

HR1001A incorporates an intelligent ADTA logic circuit, which detects SW’s dv/dt and inserts the proper dead time automatically. The external circuit is quite simple; connect a capacitor (5pF, typically) between SW and HBVS to sense dv/dt . Figure 5 shows the simplified block diagram of ADTA. Figure 6 shows the operation waveform of ADTA.

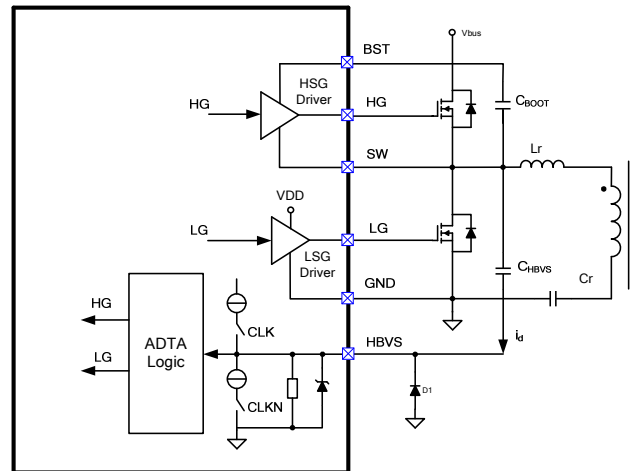

Figure 5: Block Diagram of ADTA

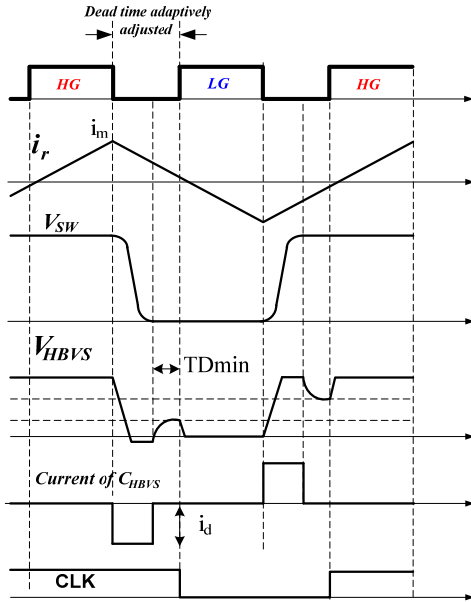

Figure 6: Operation Waveform of ADTA

When HG switches off, SW voltage swings from high to low due to the resonant tank current (i_r). Accordingly, this negative dv/dt pulls current from HBVS via C_{HBVS} . If the dv/dt current is higher than the internal comparison current, the voltage on HBVS (V_{HBVS}) is pulled down and clamped at zero. When SW stops slewing and the differential current stops, V_{HBVS} starts to ramp up. LG turns on after a delay (the minimum dead time). Dead time is defined as the duration between the moment HG turns off and the moment LG turns on.

When LG switches off, the SW voltage swings from low to high, and a positive dv/dt current is detected via C_{HBVS} . The dead time between the LG turning off and the HG turning on is maintained automatically by sensing the dv/dt current.

To avoid damaging HBVS, it should be taken care with selecting C_{HBVS} . Use Equation (8) to keep the dv/dt current below 65mA:

$$i_d = \left| C_{HBVS} \frac{dv}{dt} \right| < 65mA \quad (8)$$

If C_{HBVS} is designed too low to sense the dv/dt , the minimum voltage change rate (dv_{min}/dt) must be accounted for to design the proper C_{HBVS} .

First, calculate the peak magnetizing current (I_m) with Equation (9):

$$I_m = \frac{V_{in}}{8 \cdot L_m \cdot f_{max}} \quad (9)$$

Then use Equation (10) to design C_{HBVS} :

$$C_{HBVS} > \frac{700\mu A C_{oss}}{I_m \cdot 2} \quad (10)$$

Where C_{oss} is the output capacitance when drain-source voltage on MOSFET is near zero volts (user can refer to the C_{oss} characteristics curve in MOSFET's datasheet).

In a typical design $L_m=870\mu H$, $V_{in}=450V_{dc}$, and $f_{max}=140kHz$, C_{HBVS} is calculated at 4.5pF, indicating that 5pF is suitable for most MOSFETs.

Figure 7 illustrates a possible dead time by ADTA logic. Note that there are three kinds of dead time; minimum dead time (DT_{min}), maximum dead time (DT_{max}), and adjusted dead time (DT_{adj}), which is between DT_{min} and DT_{max} . ADTA logic sets $DT_{min}=235ns$. When the SW's transition time is smaller than DT_{min} , the logic does not let the gate turn on, which guards against shoot-through between the low-side and high-side FETs. A maximum dead time ($DT_{max}=1\mu s$) forces the gate to turn on, preventing the losses of duty cycle or soft switching.

ADTA adjusts the dead time automatically and ensures ZVS. It enables more flexibility in MOSFET and L_m selection. Also, it prevents hard switching if the design does not carefully account for light load or no load. At light load, the switching frequency goes high, and the magnetizing current goes low, risking hard switching that can lead to a thermal or reliability issue.

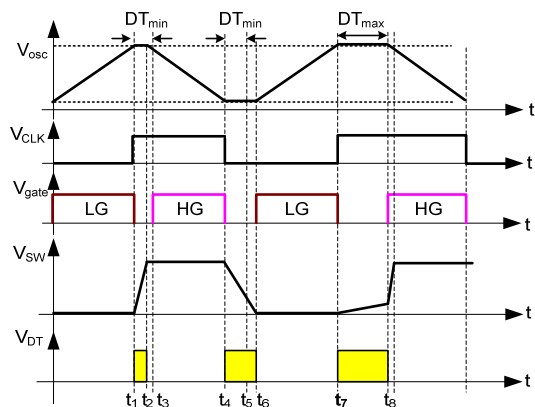

Figure 7: Dead Time in ADTA

If HBVS is not connected, the internal circuit never detects the differential current from HBVS, keeping the dead time fixed at 350ns.

Figure 8 and Figure 9 show the waveforms of the dead time when HG turns off and when LG turns off respectively. ADTA logic inserts the dead time automatically according to the transition shape of SW.

If HBVS is pulled down too low by the negative current of C_{HBVS} , the dead time from the HG turning off to the LG turning on may be too long. In order to clamp HBVS at zero and ensure an optimum dead time, a Schottky diode (D1), like BAT54, is strongly recommended to connect on HBVS to GND.

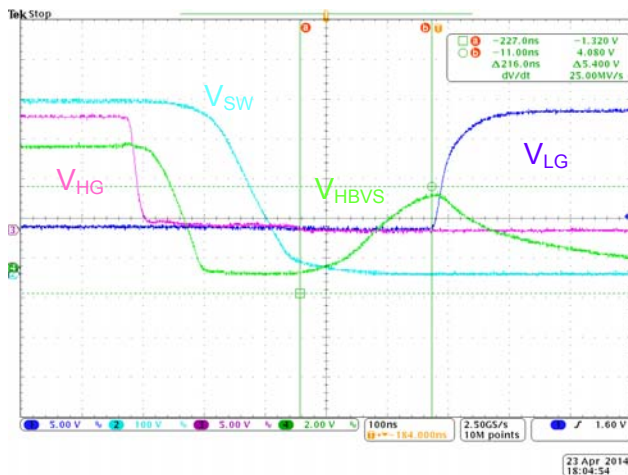

Figure 8: Dead Time at High to Low Transition

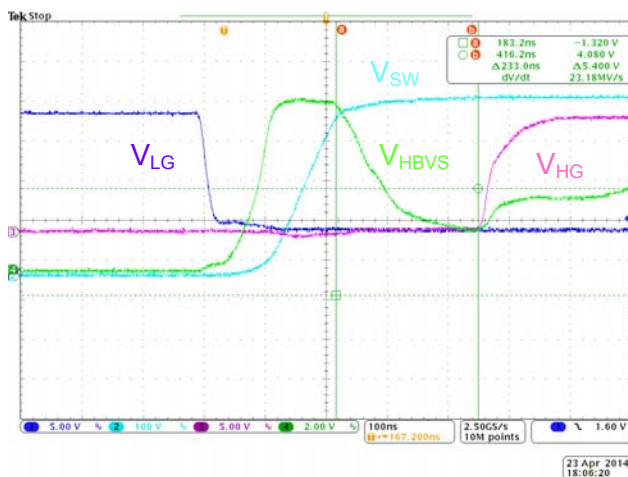

Figure 9: Dead Time at Low to High Transition

Capacitive Mode Protection (CMP)

When the resonant HB converter output is in overload or short circuit, it may cause the converter to run into a capacitive region. In capacitive mode, the voltage applied to the resonant tank causes the current of the resonant tank to lag. Under this condition, the body diode of one of the MOSFETs is conducting; the turning on of the other MOSFET should be prevented to avoid device failure.

The functional block diagram of CMP is shown in Figure 10.

Figure 11 shows the operating current principle of capacitive mode protection. CSPOS and CSNEG stand for the current polarity, which is generated by comparing the voltage on CS with the internal V_{CSNR} and V_{CSPR} voltage reference.

At t_0 , LG turns off, CSNEG is high, which means the current is in the correct direction, operating in inductive mode.

At t_1 , HG turns off. CSPOS is high, which means the current is in the correct direction, operating in inductive mode.

At t_2 , LG turns off for the second time. CSNEG is low, indicating the current is in the wrong direction (the low-side MOSFET body diode is conducting). This means the converter is operating in capacitive mode.

SW does not swing high until the current returns to the correct polarity. DT stays high and V_{OSC} is stopped, preventing the other MOSFET from turning on. This effectively avoids capacitive switching.

At t_3 , the current returns to the correct polarity, and the other MOSFET turns on after the dv/dt current is detected.

Between t_2 and t_5 , the correct current polarity cannot be detected, or there is so little current that it is unable to pull SW up or down.

Eventually, the timer ($52\mu s$) for CMP expires, and the other MOSFET is forced to switch on (see Figure 11).

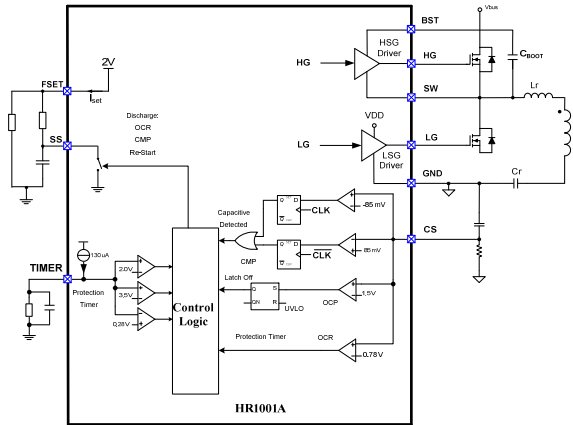

Figure 10: Block Diagram of CMP and OCP

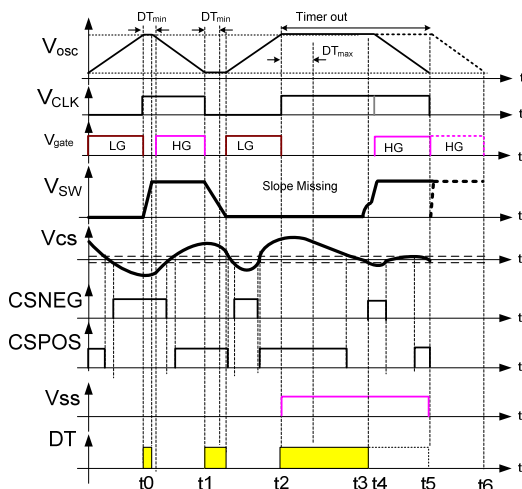

Figure 11 Operating Principle of CMP

When capacitive mode operation is detected, the V_{SS} control signal goes high, turning on an internal transistor to discharge C_{SS} (after a 1μs blanking delay). This causes the frequency to increase to a very high level quickly to limit the output power. The V_{SS} control is reset, and the soft start is activated when the first gate driver is switched off after CMP. The switching frequency decreases smoothly until the control loop takes over.

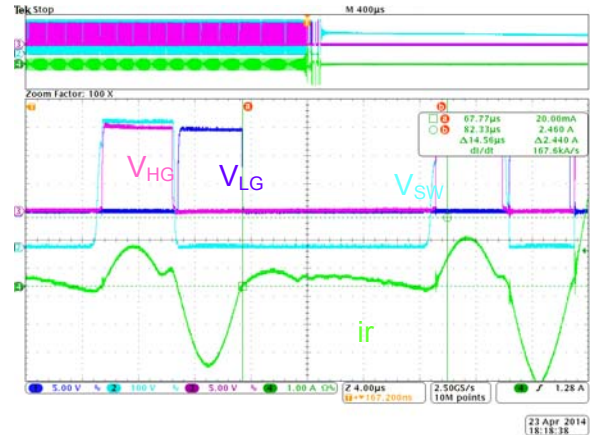

Figure 12: Capacitive Mode Protection Waveform

Figure 12 shows CMP behavior when the output is shorted. The current polarity goes in the wrong direction when LG switches off. The CMP logic detects this capacitive mode immediately and prevents HG from turning on. This avoids destructive capacitive switching. Once the current (i_r) returns to the right polarity, SW ramps up, dv/dt current is detected, and HG turns on at the ZVS condition.

Over-Current Protection (OCP)

HR1001A provides two levels of over-current protection, as shown in Figure 13.

1. The first level of protection occurs when the voltage on CS (V_{CS}) exceeds 0.78V. Once this occurs, and two actions take place:

First, the internal transistor connected between SS and GND turns on for at least 10μs, which discharges C_{SS}. This creates a sharp increase in the oscillator frequency, reducing the energy transferred to the output.

Second, an internal 130μA current source turns on to charge C_{TIMER}, ramping the TIMER voltage.

If V_{CS} drops below 0.78V before the voltage on TIMER (V_{TIMER}) reaches 2V, both the discharge of C_{SS} and the charge of C_{TIMER} are stopped. The converter returns to normal operation.

t_{OC} is the time for V_{TIMER} to rise from 0V to 2V. It is a delay time for over-current regulation. There is no simple relationship between t_{OC} and C_{TIMER} . Select C_{TIMER} based on experimental results (based on experiments: C_{TIMER} may increase the operating time by 100ms.)

If V_{CS} is still larger than 0.78V after V_{TIMER} rises to 2V, C_{SS} is discharged completely. At the same time, the internal 130 μ A continues to charge C_{TIMER} until V_{TIMER} reaches 3.5V, then turns off all gate drivers.

Use Equation (11) to calculate the time it takes for V_{TIMER} to rise from 2V to 3.5V:

$$t_{OP} = 10^4 \cdot C_{TIMER} \quad (11)$$

It maintains the condition until V_{TIMER} decreases to 0.28V. then the IC restarts. Use Equation (12) to calculate this time period:

$$t_{OFF} = R_{TIMER} \cdot C_{TIMER} \cdot \ln \frac{3.5}{0.28} \approx 2.5 R_{TIMER} \cdot C_{TIMER} \quad (12)$$

2. The second level of over-current protection is triggered when V_{CS} rises to 1.5V. Normally, this condition happens when V_{CS} continues to rise during a short circuit. The IC stops switching immediately and C_{SS} is discharged completely. The internal 130 μ A current source turns on to charge C_{TIMER} . Once V_{TIMER} is charged up to 3.5V, the charge current turns off. The IC restarts when V_{TIMER} falls below 0.28 V.

The time sequence of OCP is shown in Figure 13. OCP limits the energy transferred from the primary side to the secondary side during an overload or short-circuit condition. Excessive power consumption due to high continuous currents can damage the secondary-side windings and the rectifiers. TIMER provides additional protection to reduce the average power consumption. When OCP is triggered, the converter enters a hiccup-like protection mode that operates intermittently.

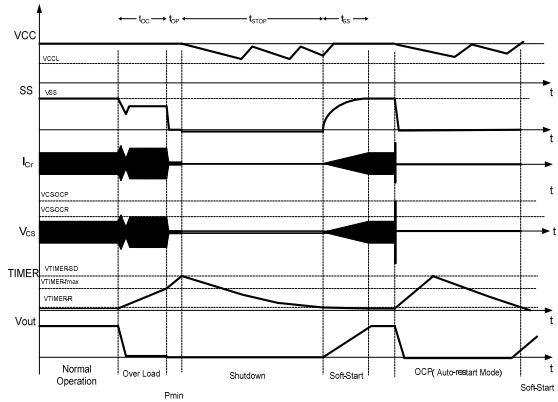

a

Figure 13: OCP Timing Sequence

Current Sensing

There are two current sensing methods: lossless current sensing and current sensing with a sense resistor.

Generally, a lossless current sensing solution is used in high-power applications, as shown in Figure14.

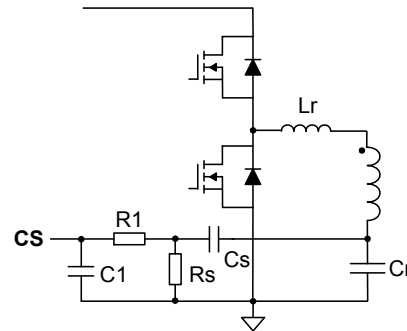

Figure 14: Current Sensing with a Lossless Network

Use Equation (13) and Equation (14) to design a lossless current sensing network:

$$C_s \leq \frac{C_r}{100} \quad (13)$$

R_s chosen must be according to the equation below:

$$R_s < \frac{0.8}{I_{Crpk}} \cdot \left(1 + \frac{C_r}{C_s}\right) \quad (14)$$

I_{Crpk} is the peak current of the resonant tank at low input voltage and full load, which is expressed in Equation (15):

$$I_{Crpk} = \sqrt{\left(\frac{NV_O}{4L_m f_s}\right)^2 + \left(\frac{I_O \pi}{2N}\right)^2} \quad (15)$$

Where, N is the turns ratio of transformer, I_o and V_o are the output current and voltage, f_s is the switching frequency, and L_m is the magnetizing inductance.

For capacitive mode detection in no load or tiny load condition, R_s should fulfill the condition in Equation (16) as well:

$$R_s > \frac{85mV}{I_m} \left(1 + \frac{C_r}{C_s}\right) \quad (16)$$

In some conditions, especially large L_m used, it's difficult to fulfill Equation (14) and (16) both. It operates without CMP function at light load if it's without the restriction of Equation (16).

The R1 and C1 network is used to attenuate switching noise on CS. The time constant should be in the range of 100ns.

An alternate solution uses a sense resistor in series with the resonant tank, as shown in the Figure 15. This method is simple but causes unnecessary power loss on the sense resistor.

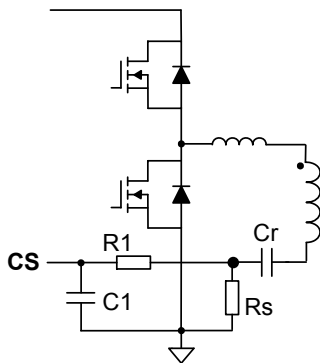

Figure 15: Current Sensing with a Sense Resistor

Design the sense resistor using Equation (17):

$$R_s = \frac{0.78}{I_{Crpk}} \quad (17)$$

Input Voltage Sensing (BI/BO)

HR1001A stops switching when the input voltage drops below a specified value. It restarts when the input voltage returns to normal. This function guarantees that the resonant half-bridge converter always operates within the specified input-voltage range. The IC senses the voltage on BO (V_{BO}) through the tap of a resistor divider connected to the rectified AC voltage or the PFC output.

Figure 16 shows the line-sensing internal block diagram.

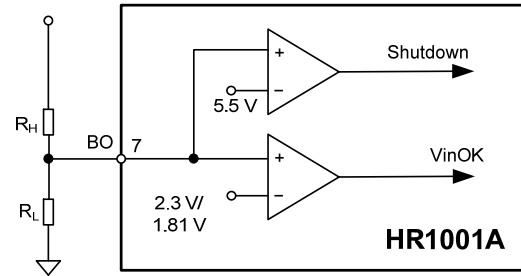

Figure 16: Input Voltage Sensing Block

If V_{BO} is higher than 2.3V, the IC provides the gate driver outputs; the IC does not stop the gate driver until V_{BO} drops below 1.81V.

First, for a minimum operation input voltage of half-bridge (V_{IN-min}), select a value for R_H large enough to reduce power loss at no load. Then R_L is calculated with Equation (18):

$$R_L = R_H \cdot \frac{1.81}{V_{IN-min} - 1.81} \quad (18)$$

For additional protection, the IC shuts down when V_{BO} exceeds the internal 5.5V clamp voltage. When V_{BO} is between 2.3V and 5.5V, the IC operates normally.

Burst Mode Operation

At light load or in the absence of a load, the maximum frequency limits the resonant half-bridge switching frequency. To control the output voltage and limit power consumption, HR1001A enables compatible converters to operate in burst mode. This greatly reduces the average switching frequency, thus reducing the average residual magnetizing current and the associated losses.

Operating in burst mode requires setting BURST. If the voltage on BURST (V_{BURST}) drops below 1.23V, HR1001A shuts down the HG and LG gate drive outputs, only leaving the 2V reference voltage on FSET and SS to retain the previous state and minimize the power consumption. When V_{BURST} exceeds 1.23V over 30mV, HR1001A resumes normal operation.

Based on the burst mode operating principle, the BURST must be connected to the feedback loop. Figure 17 shows a typical circuit

connecting BURST to the feedback signal for narrow-input-voltage range applications.

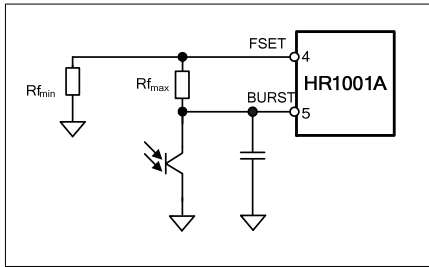

Figure 17: Burst Mode Operation Set-Up

In addition to setting the oscillator maximum frequency at start-up, $R_{f_{max}}$ determines the maximum burst mode frequency. After confirming f_{max} , calculate $R_{f_{max}}$ with Equation (19):

$$R_{f_{max}} = \frac{3}{8} \cdot \frac{R_{f_{min}}}{\frac{f_{max}}{f_{min}} - 1} \quad (19)$$

Here, f_{max} corresponds to a load point (P_{Burst}), where the peak current flow through the transformer is too low to cause audible noise.

The above introduction is based on a narrow-input-voltage range. As a property of the resonant circuit, the input voltage determines the switching frequency as well. This means P_{Burst} has a large variance over the wide-input-voltage range. To stabilize P_{Burst} over the input range, use the circuit in Figure 18 to insert the input voltage signal into the feedback loop.

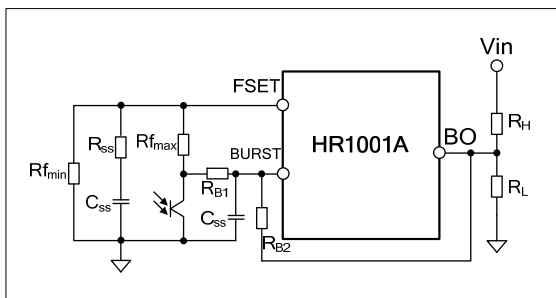

Figure 18: Burst Mode Operation Set-Up for a Wide Input Voltage Range

R_{B1} and R_{B2} in Figure 18 correct against the wide-input-voltage range. Select both resistors based on experimental results. Note that the total resistance of R_{B1} and R_{B2} should be much larger than R_H to minimize the effect on V_{BO} . During burst mode operation, when the load is lower than P_{Burst} , the switching frequency is clamped at the maximum frequency. The output voltage

must rise over the setting value, which increases the current flowing through the optocoupler. Therefore, the voltage on $R_{f_{max}}$ rises due to the increased phototransistor current. Then V_{BURST} drops below 1.23V, triggering the gate signal off state. Until the output voltage falls below the setting value, the current flow through the optocoupler decreases, causing V_{BURST} to rise. When V_{BURST} exceeds 1.23V over 30mV, the IC restarts to generate the gate signal. The IC operates in this mode under no load or light load to decrease the average power consumption.

Latch Operation

HR1001A provides a simple latch-off function through LATCH. Applying an external voltage over 1.85V causes the IC to enter a latched shutdown. After the IC is latched, its consumption drops, as shown by the residual current in the EC table. Resetting the IC requires dropping the VCC voltage below the UVLO threshold (see the latch internal block diagram in Figure 19).

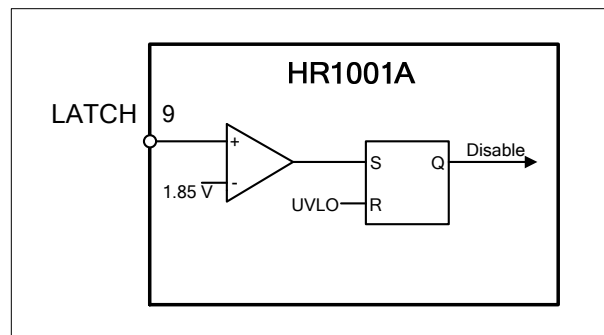

Figure 19: Latch Function Block

High-Side Gate Driver

The external BST capacitor provides energy to the high-side gate driver. An integrated bootstrap diode charges this capacitor through VCC. This diode simplifies the external driving circuit for the high-side switch, allowing the BST capacitor to charge when the low-side MOSFET is on (see the high-side gate driver internal block diagram in Figure 20).

To provide enough gate driver energy (considering the BST capacitor charge time), use a 100nF to 470nF capacitor for the BST capacitor.

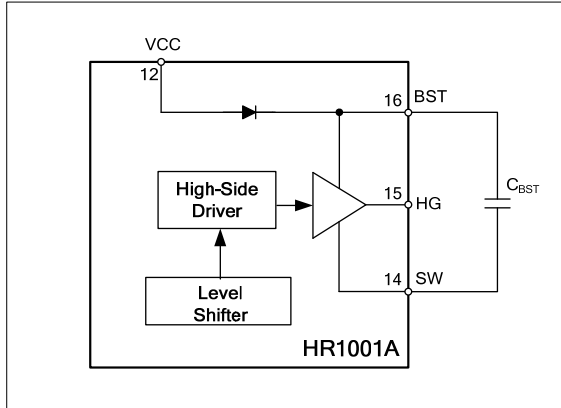

Figure 20: High-Side Gate Driver

Low-Side Gate Driver

LG provides the gate driver signal for the low-side MOSFET. The maximum absolute rating table shows the maximum voltage on LG is 16V. Under some conditions, a large voltage spike occurs on LG due to oscillations from the long gate-driver wire, the MOSFET parasitic capacitance, and the small gate-driver resistor. This voltage spike is dangerous to LG, so a 15V Zener diode close to LG and GND pins is recommended (as shown in Figure 21).

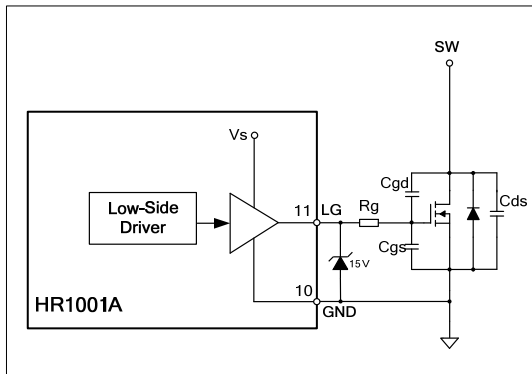

Figure 21: Low-Side Gate Driver

Design Example

A 100W LED driver is designed with the specifications below (see Table 1):

Table 1: Design Example

| | |
|-------------------------|-----------|
| Input AC voltage | 90-305VAC |
| Output voltage | 24V |
| Output current | 4.16A |

Figure 22 shows the detailed application schematic. The typical performance and circuit waveforms have been shown in the “Typical Performance Characteristics” section.

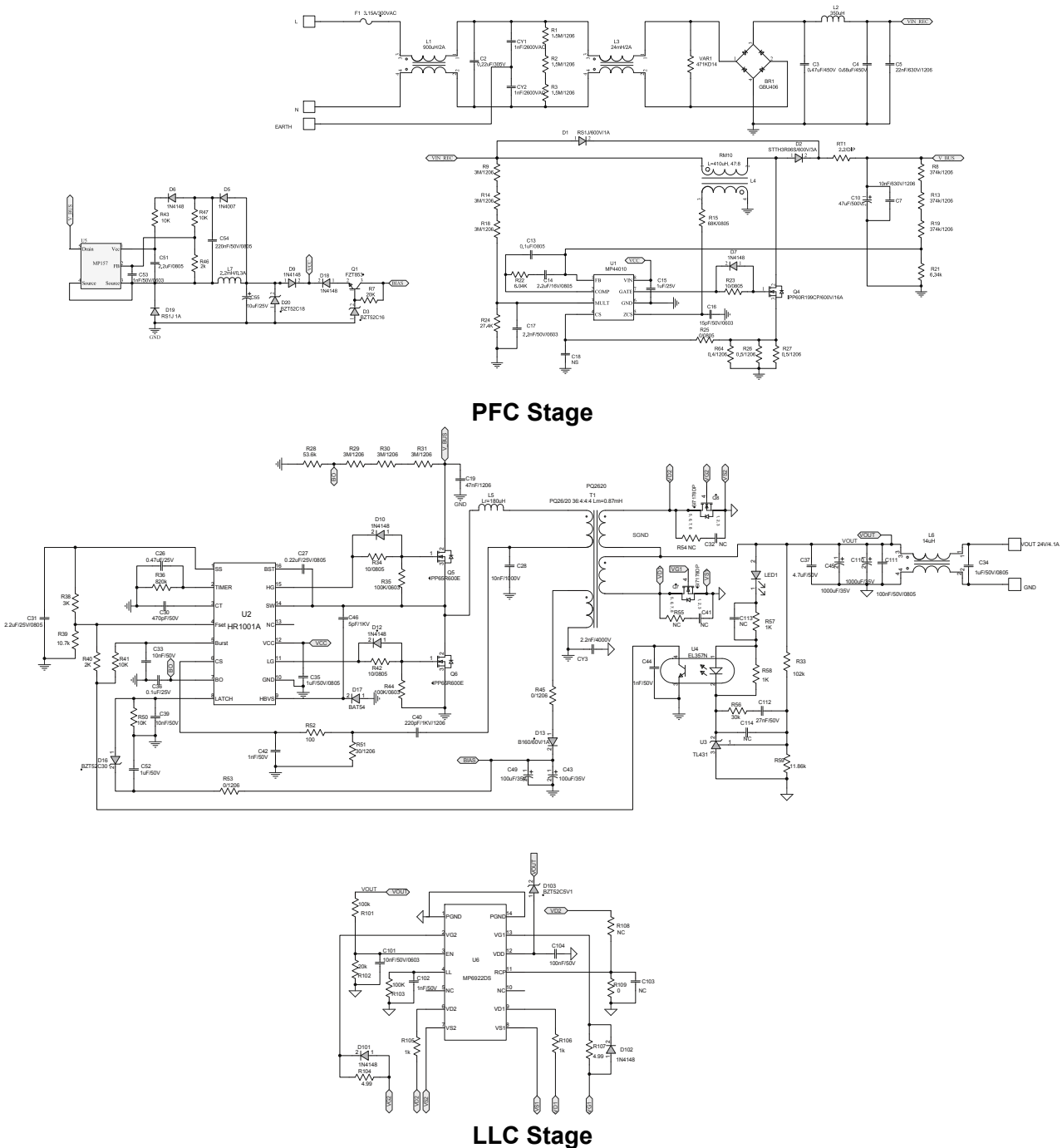

Figure 22: Design Example for a 24V/4.16A Output

CONTROL FLOW CHARTS

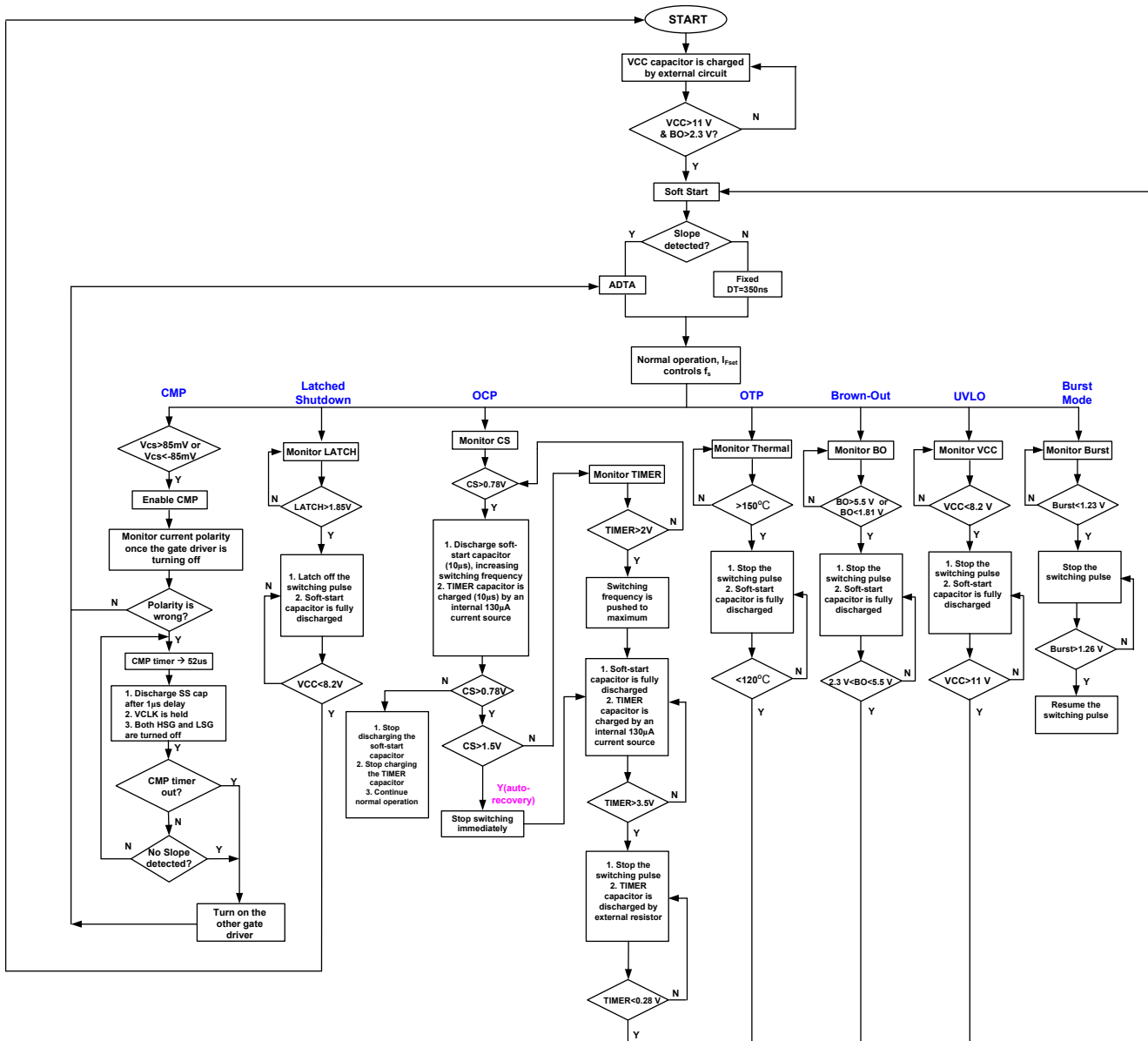

Figure 23: Control Flow Chart

TYPICAL APPLICATION CIRCUITS

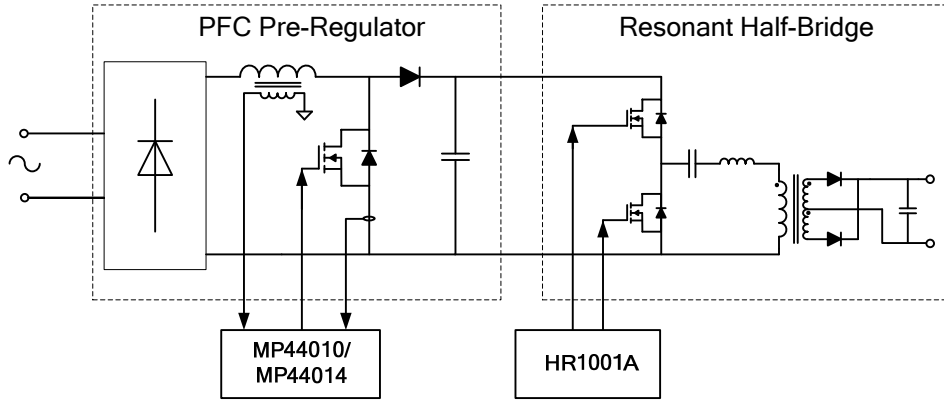
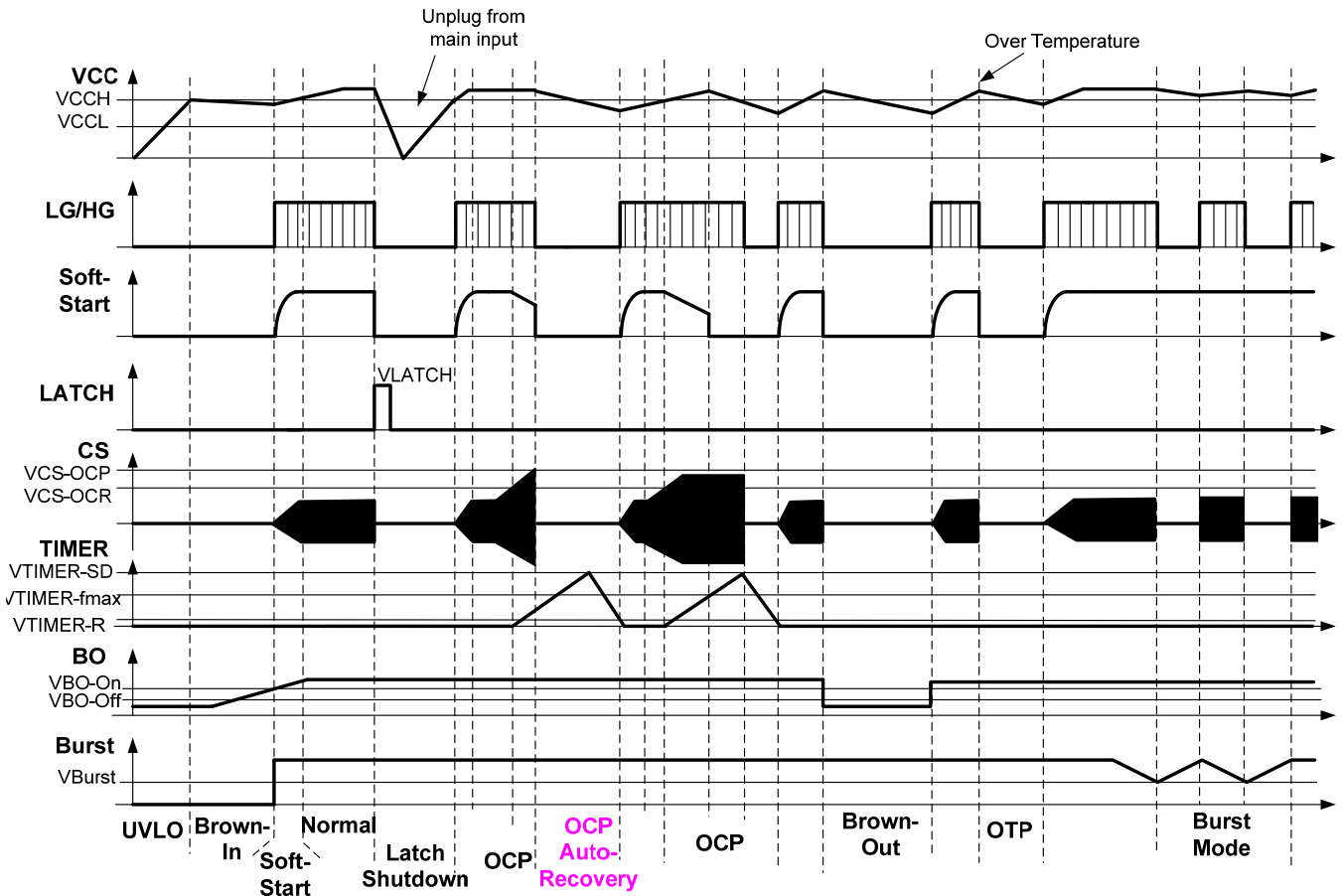

Figure 24: Application Circuit

SYSTEM TIMING



PACKAGE INFORMATION

SOIC-16

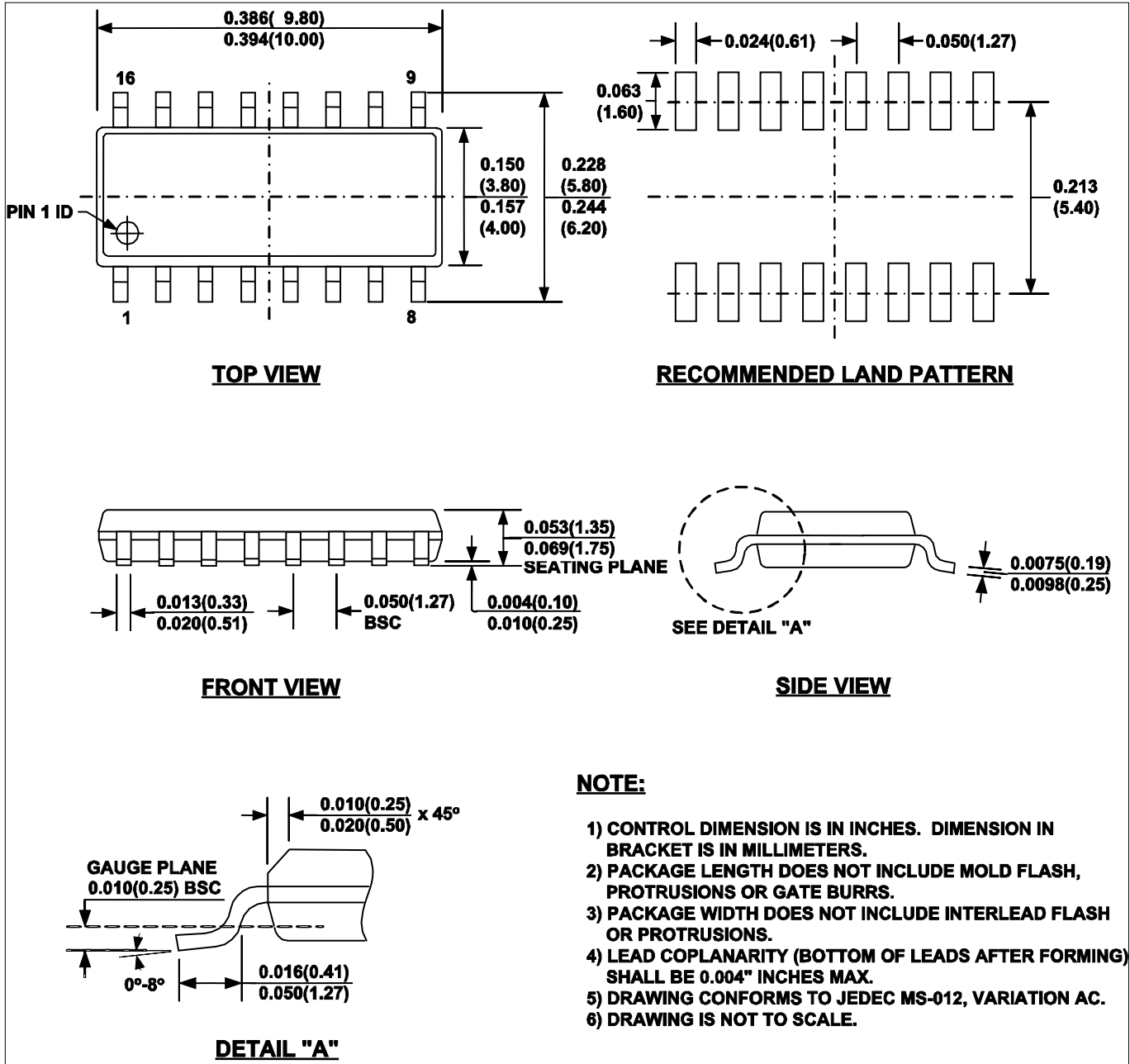

NOTICE: The information in this document is subject to change without notice. Users should warrant and guarantee that third party Intellectual Property rights are not infringed upon when integrating MPS products into any application. MPS will not assume any legal responsibility for any said applications.

X-ON Electronics

Largest Supplier of Electrical and Electronic Components

Click to view similar products for [AC/DC Converters](#) category:

Click to view products by [Monolithic Power Systems](#) manufacturer:

Other Similar products are found below :

[BP5037B15](#) [BP5722A12](#) [ICE3RBR4765JZ](#) [BP5011](#) [BP5710-1](#) [BP5718A12](#) [NCP1124BP100G](#) [NCP1341B1D1R2G](#) [AP3125CMKTR-G1](#)
[SC1076P065G](#) [47132](#) [NCP1126BP100G](#) [HF500GP-40](#) [MP171AGS-P](#) [MP172AGS-P](#) [MP173AGS-P](#) [MP173AGJ-P](#) [AP3983CMTR-G1](#)
[NCP1050P100G](#) [NCP1077BAP130G](#) [NCP11187A100PG](#) [NCP1341B4D1R2G](#) [ICE5QR2270AZ](#) [INN3368C-H302-TL](#) [ICE5QR4780AZ](#)
[ICE2QR1080G](#) [TNY177DG-TL](#) [VIPER013BLS](#) [RAA2230114GSP#HA1](#) [HF900GPR](#) [TNY285PG](#) [TNY286PG](#) [TNY287PG](#) [TNY288DG-TL](#)
[TNY288PG](#) [TOP255PN](#) [MP020-5GS-Z](#) [MP150GJ-P](#) [BP5034D24](#) [ICE2QR0665ZXKLA1](#) [ICE2QR2280Z1XKLA1](#) [ICE2QS02GXUMA1](#)
[ICE3A1065ELJFKLA1](#) [ICE3AR2280JZXKLA1](#) [ICE3B1565JFKLA1](#) [ICE3RBR0665JZ](#) [INN2004K](#) [INN2123K](#) [INN3162C-H101-TL](#)
[INN3164C-H101-TL](#)