

BASE CAGE DETAILS

(APPLIES TO ALL CAGES IN THIS DRAWING)

747540610
 SHOWN

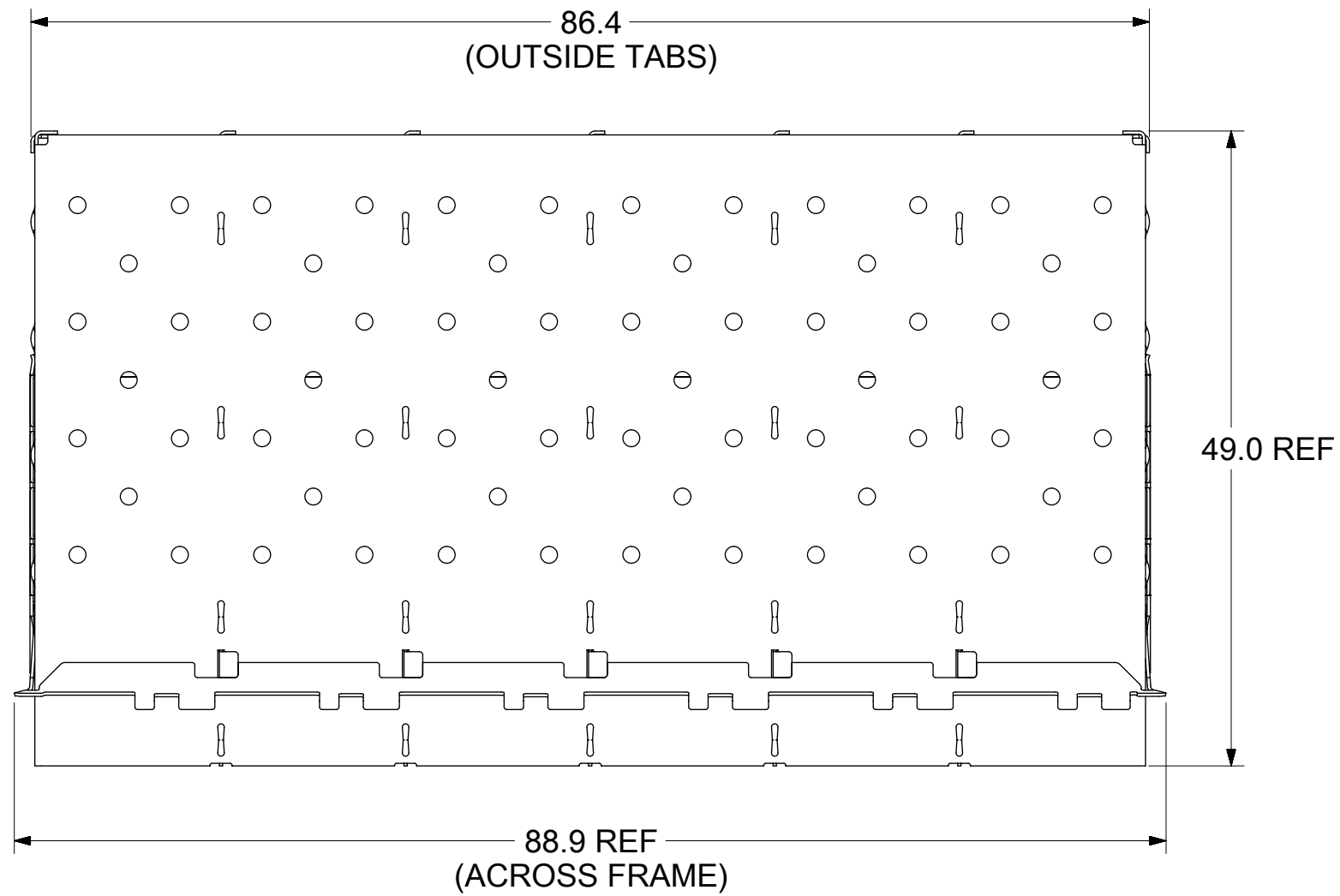

360° SOFT ELASTOMERIC GASKET

INNER WALLS ARE COINED FOR EXTRA RIGIDITY

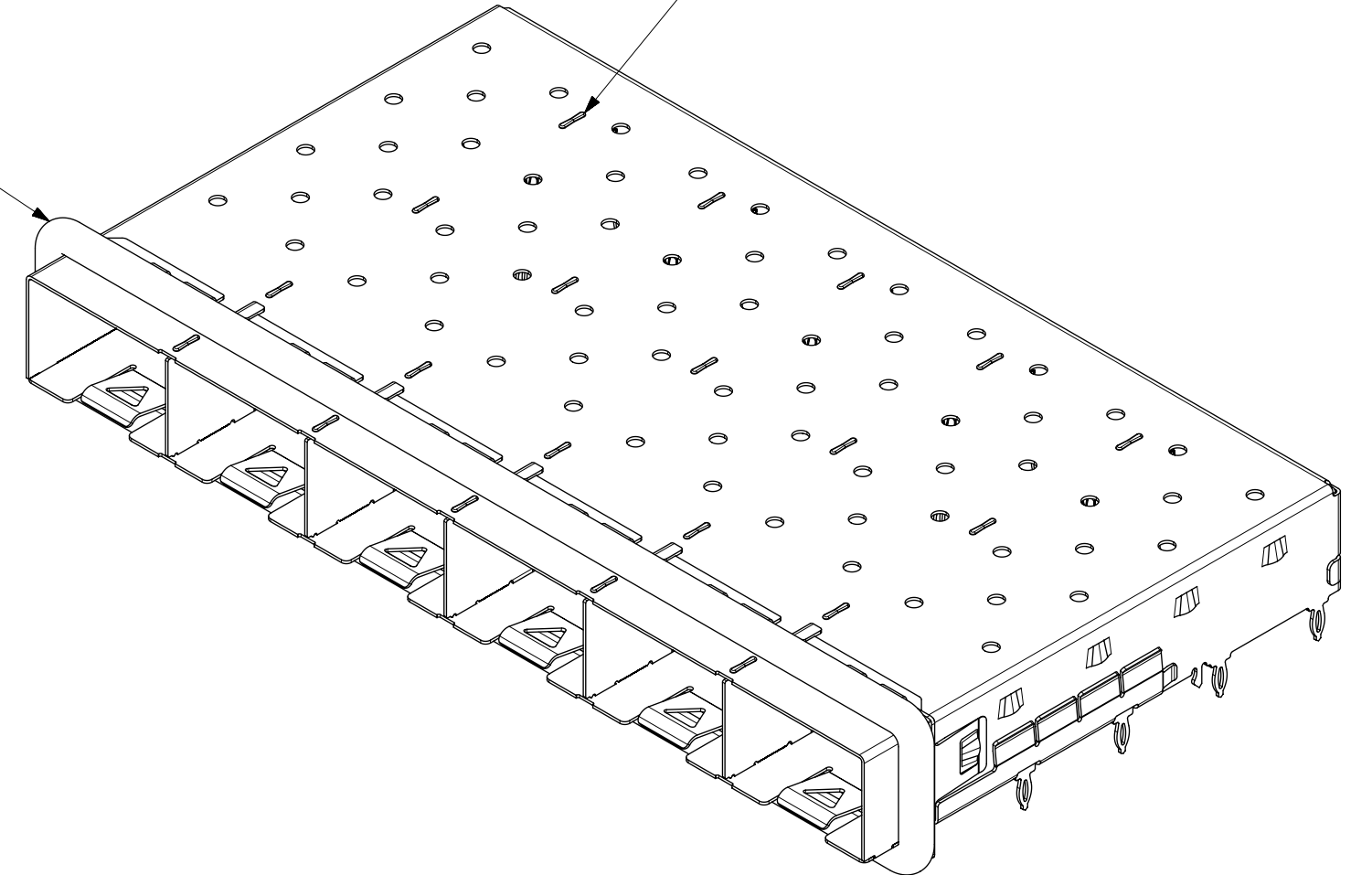

NOTE:
 EMI GASKET REMOVED FROM THIS VIEW FOR CLARITY.

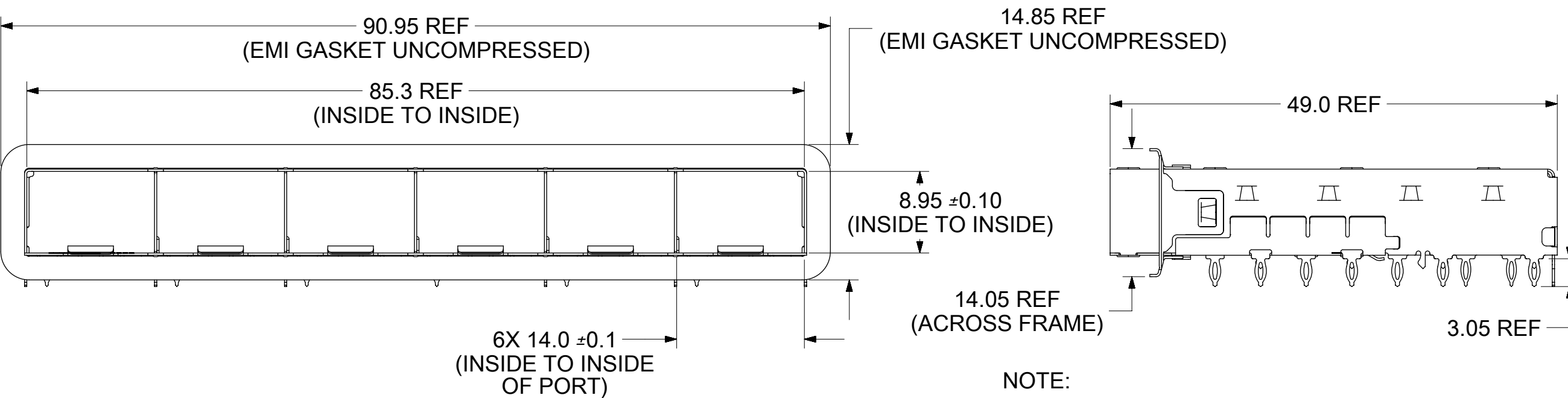

NOTE:
 EMI GASKET REMOVED FROM THIS VIEW FOR CLARITY.

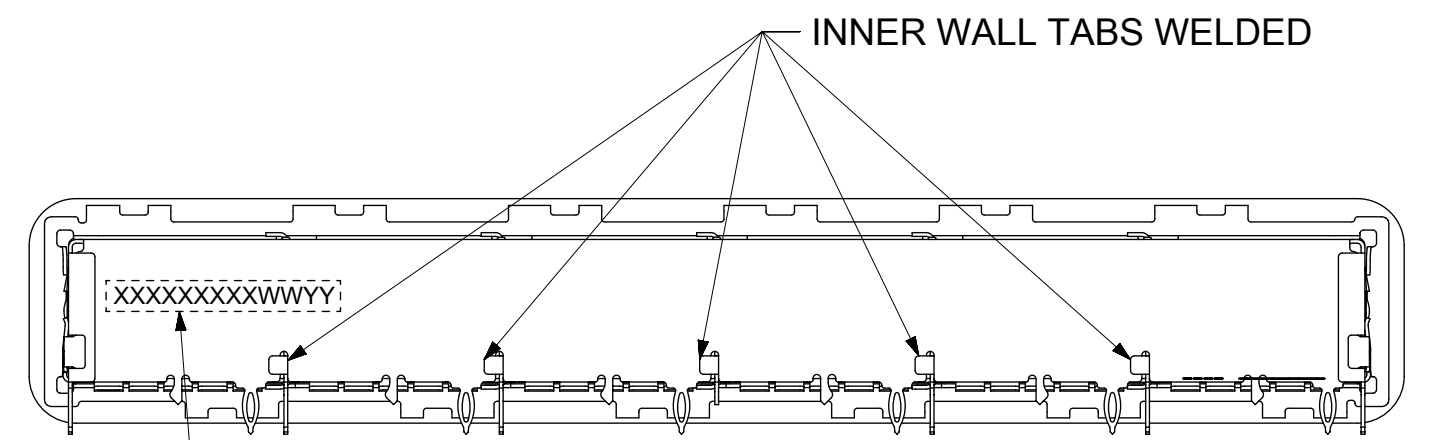

- NOTES:
- MATERIAL:
 CAGE: 0.25mm THICK COPPER ALLOY, NICKEL PLATED.
 SPRING FINGERS: 0.10mm THICK COPPER ALLOY, NICKEL PLATED.
 HEATSINK: ALUMINUM, NICKEL PLATED.
 HEATSINK SPRING CLIP: STAINLESS STEEL.
 - PRESS FIT LEGS 3.05mm LONG:
 - PORTS ARE DESIGNED FOR SFP+ TRANSCEIVERS AND ARE COMPATIBLE WITH SFP TRANSCEIVERS. THE TOP SURFACE OF THE MODULE MUST BE FLAT (NO PRODUCT LABEL RECESS) AND THERMALLY CONDUCTIVE TO FUNCTION OPTIMALLY.
 - WELD SPOT MAY SHOW SLIGHT MATERIAL DISCOLORATION.
 - NO RoHS EXEMPTIONS.
 - CUSTOM HEATSINKS AVAILABLE UPON REQUEST.

WEEK/YEAR DATE CODE TABLE	
WW	01 THRU 52, EXAMPLE: 01 = FIRST WEEK OF YEAR, 52 = LAST WEEK OF YEAR
YY	17, 18, 19 ETC. EXAMPLE: YEAR 2017 = 17

THIS DRAWING CONTAINS INFORMATION THAT IS PROPRIETARY TO MOLEX ELECTRONIC TECHNOLOGIES, LLC AND SHOULD NOT BE USED WITHOUT WRITTEN PERMISSION

SEE REVISION TABLE EC NO: 116175 DRWN: MHANUMAPPARE CHKD: DSUN15 REV APPR: RCHEN08	2017/02/27	2017/04/27	2017/05/03	GENERAL TOLERANCES (UNLESS SPECIFIED) ANGULAR TOL ± 1.0 ° 4 PLACES ± 3 PLACES ± 2 PLACES ± 0.13 1 PLACE ± 0.25 0 PLACES ± DRAFT WHERE APPLICABLE MUST REMAIN WITHIN DIMENSIONS	DIMENSION UNITS MM	SCALE 2:1			
	DRWN BY MHANUMAPPARE	DATE 2017/02/27	DRWN BY DSUN15		DATE 2017/04/27	PRODUCT CUSTOMER DRAWING			
	CHKD BY DSUN15	DATE 2017/04/27	APPR BY RCHEN08		DATE 2017/05/03	SERIES 111112		MATERIAL NUMBER SEE SHEET 4	CUSTOMER GENERAL MARKET
	DRAWING SIZE C	THIRD ANGLE PROJECTION	DOCUMENT NUMBER 1111122610		DOC TYPE PSD	DOC PART ASY		SHEET NUMBER 1 OF 9	

CAGE ASSEMBLY OPTIONS

OPEN TOP
111120610
SHOWN
(APPLIES TO ALL
OPEN TOP CAGES)

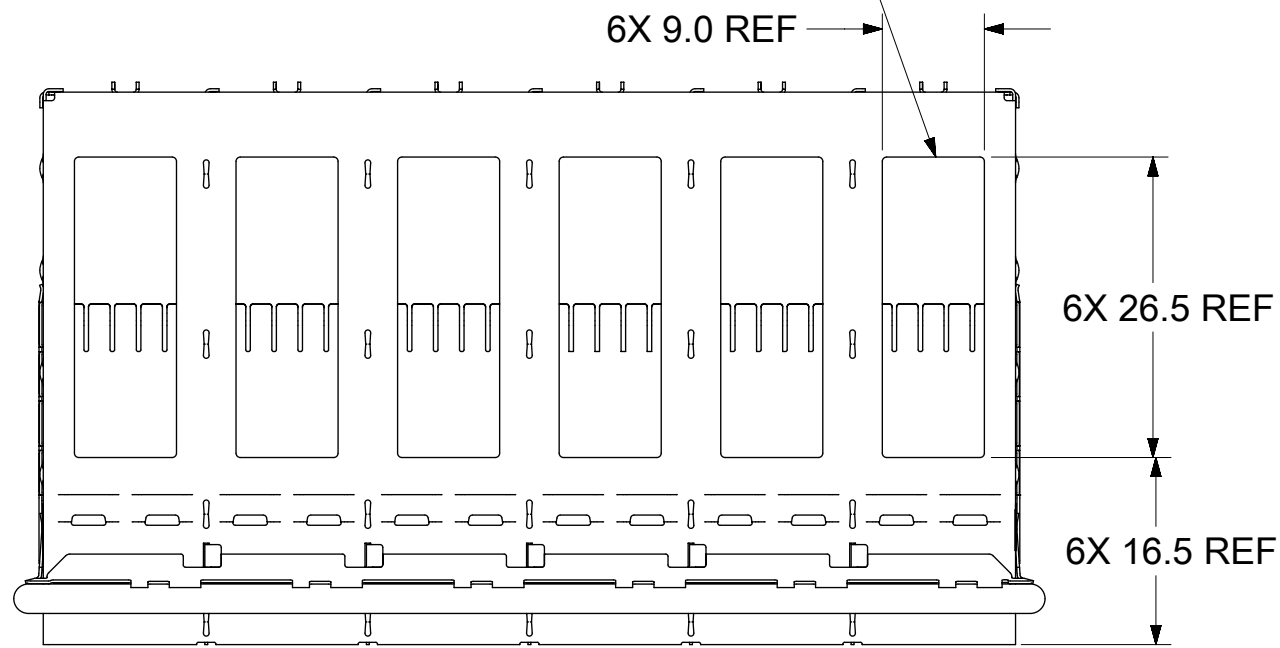

HEATSINK OPTIONS

PIN FIELD NETWORKING
PIN FIELD SAN
PIN FIELD PCI

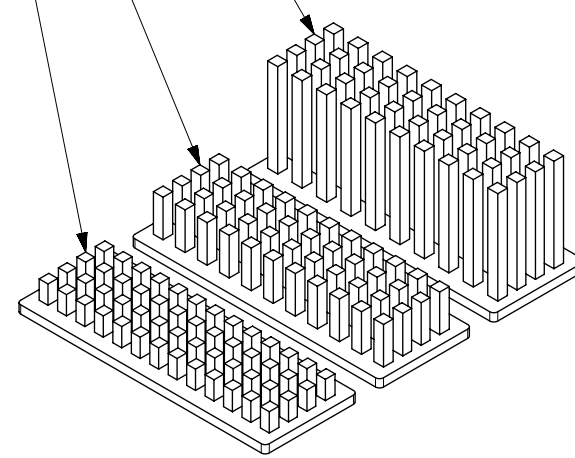

OVERALL HEATSINK HEIGHT

APPLICATION	DIM 'A'
PCI	14.3
SAN	16.6
NETWORKING	23.6

NOTE: PCI - 13 ROWS
SAN - 11 ROWS
NETWORKING - 10 ROWS

HEATSINK OPTIONS

LATERAL FIN NETWORKING
LATERAL FIN SAN
LATERAL FIN PCI

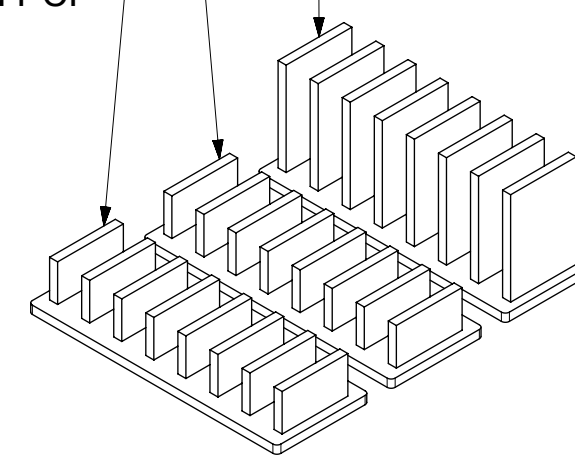

OVERALL HEATSINK HEIGHT

APPLICATION	DIM 'A'
PCI	14.3
SAN	16.6
NETWORKING	23.6

HEATSINK OPTIONS

WIDE GAP PIN NETWORKING
WIDE GAP PIN SAN
WIDE GAP PIN PCI

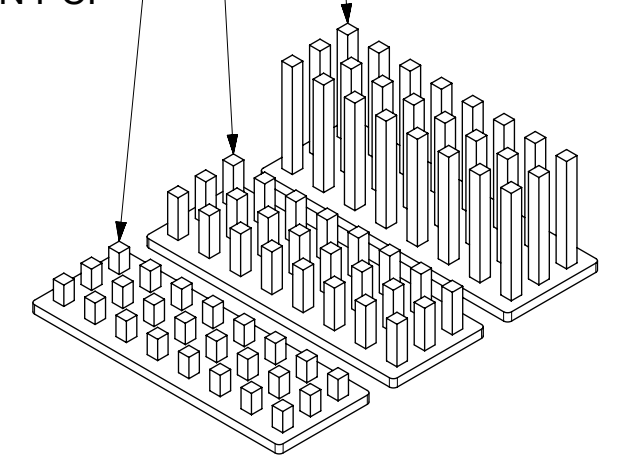

OVERALL HEATSINK HEIGHT

APPLICATION	DIM 'A'
PCI	14.3
SAN	16.6
NETWORKING	23.6

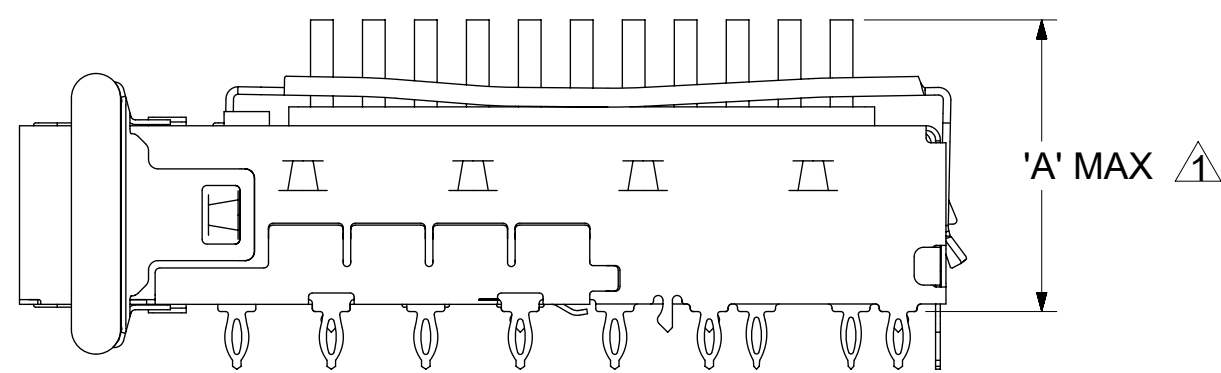

NOTES:
HEIGHT OF HEATSINK WITH MODULE INSERTED.
DIMENSION MAY BE LESS DUE TO MODULE AND HEATSINK VARIATIONS.

OPTIONAL POLYIMIDE INSULATOR
ATTACHED TO BOTTOM OF CAGE
MATERIAL NUMBER 739300634
(REFERENCE)

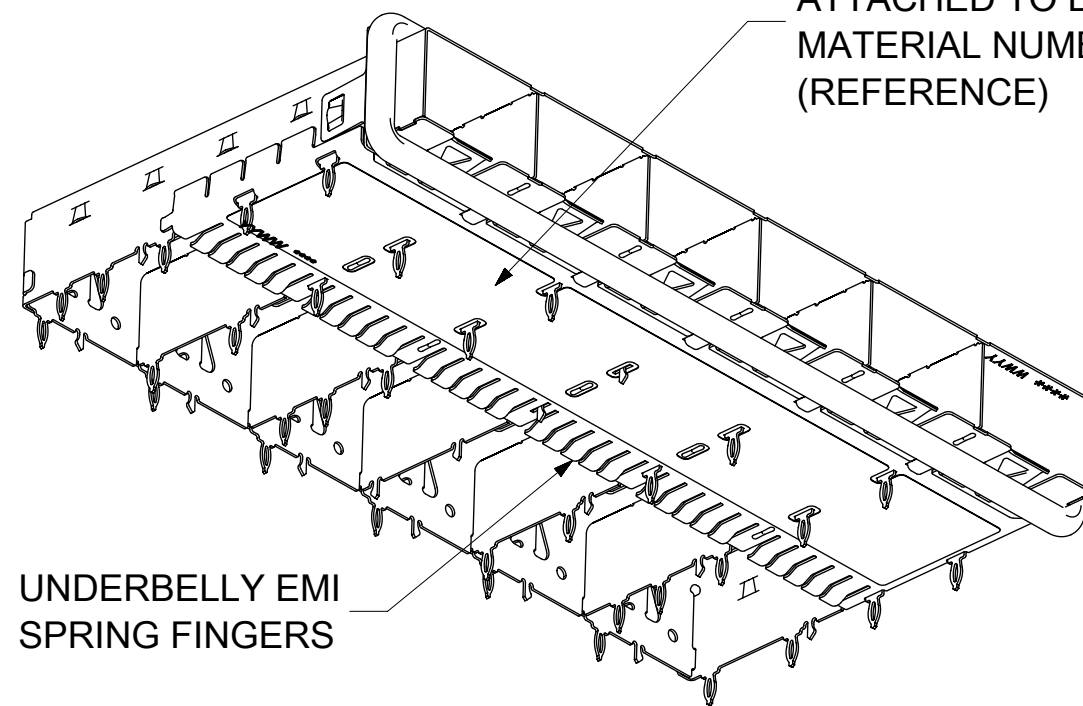

UNDERBELLY EMI
SPRING FINGERS

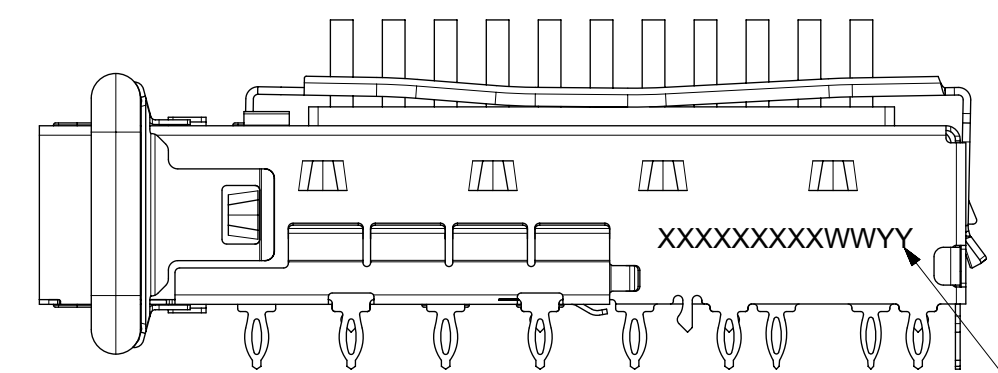

PN/DATE CODE TO BE PRINTED ON THE SIDE OF
COMPLETED CAGE ASSEMBLY APPROXIMATELY AS SHOWN.

WEEK/YEAR DATE CODE TABLE

WW	01 THRU 52, EXAMPLE: 01 = FIRST WEEK OF YEAR, 52 = LAST WEEK OF YEAR
YY	17, 18, 19 ETC. EXAMPLE: YEAR 2017 = 17

REAR LEG OPTIONS

(PER PORT)

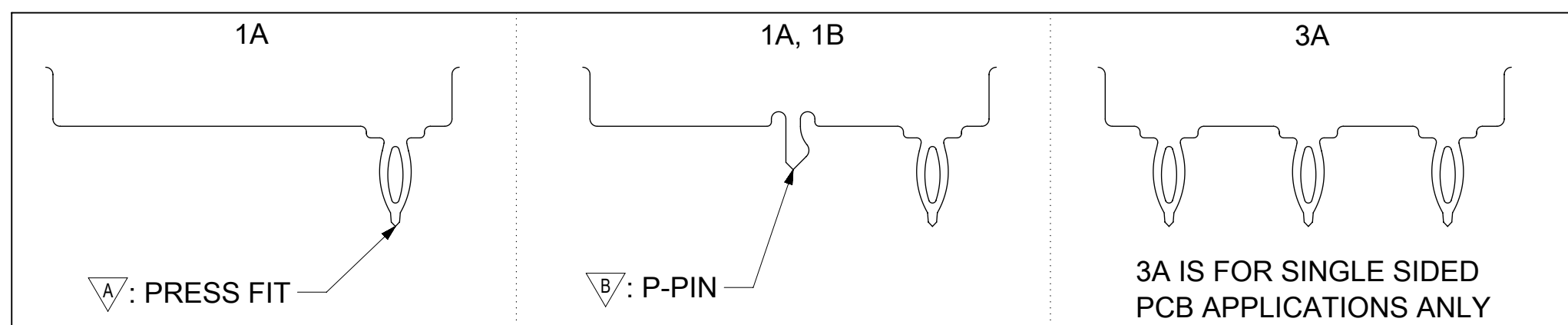

THIS DRAWING CONTAINS INFORMATION THAT IS PROPRIETARY TO MOLEX ELECTRONIC TECHNOLOGIES, LLC AND SHOULD NOT BE USED WITHOUT WRITTEN PERMISSION

SEE REVISION TABLE EC NO: 116175 DRWN: MHANUMAPPARE CHKD: DSUN15 REV: APPR: RCHEN08	2017/02/27	GENERAL TOLERANCES (UNLESS SPECIFIED) ANGULAR TOL ± 1.0 ° 4 PLACES ± 3 PLACES ± 2 PLACES ± 0.13 1 PLACE ± 0.25 0 PLACES ± DRAFT WHERE APPLICABLE MUST REMAIN WITHIN DIMENSIONS	DIMENSION UNITS	SCALE	
	2017/04/27		MM	1.5:1	
	2017/05/03		DRWN BY	DATE	
			MHANUMAPPARE	2017/02/27	
	CHKD BY	DATE	1X6 SFP+ CAGE, 120 INCH PRESS FIT, HEAT SINK, ELASTOMERIC GASKET		
	DSUN15		PRODUCT CUSTOMER DRAWING		
	RCHEN08	2017/04/27	SERIES MATERIAL NUMBER CUSTOMER		
		2017/05/03	111112 SEE SHEET 4 GENERAL MARKET		
			DOCUMENT NUMBER 111122610 DOC TYPE PSD DOC PART ASY SHEET NUMBER 2 OF 9		

OPTIONAL GEN 2 UNDER BELLY GASKET

1001150610

SHOWN

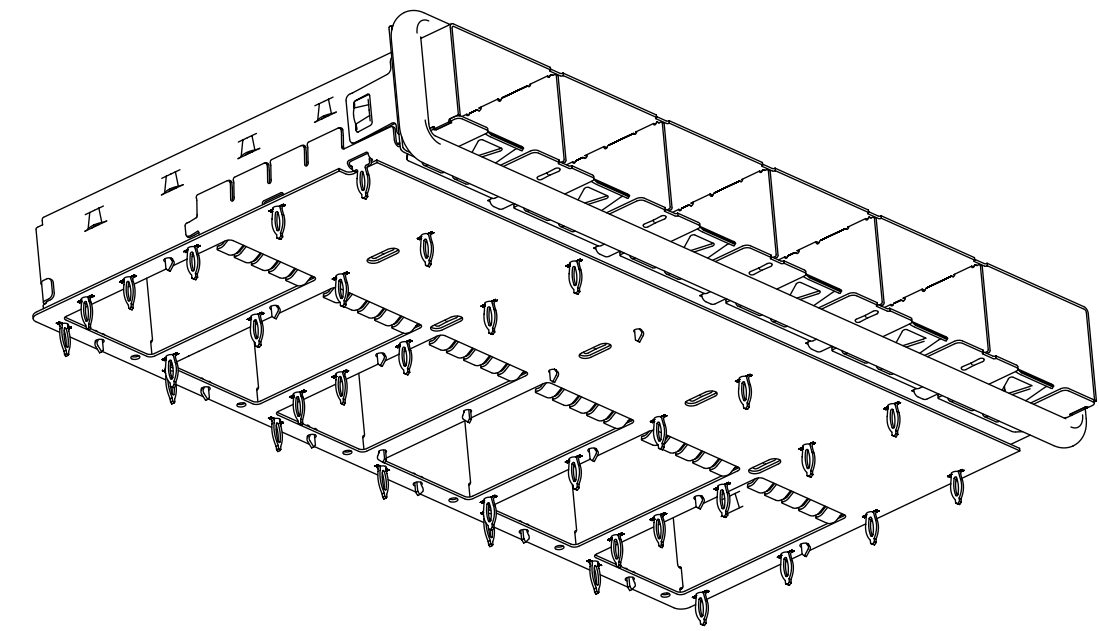
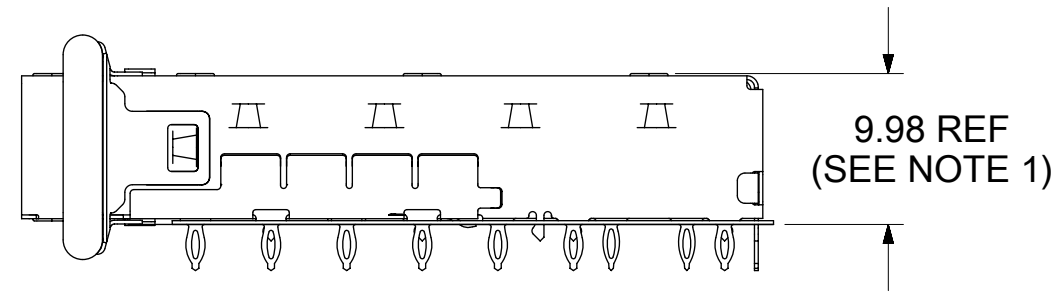
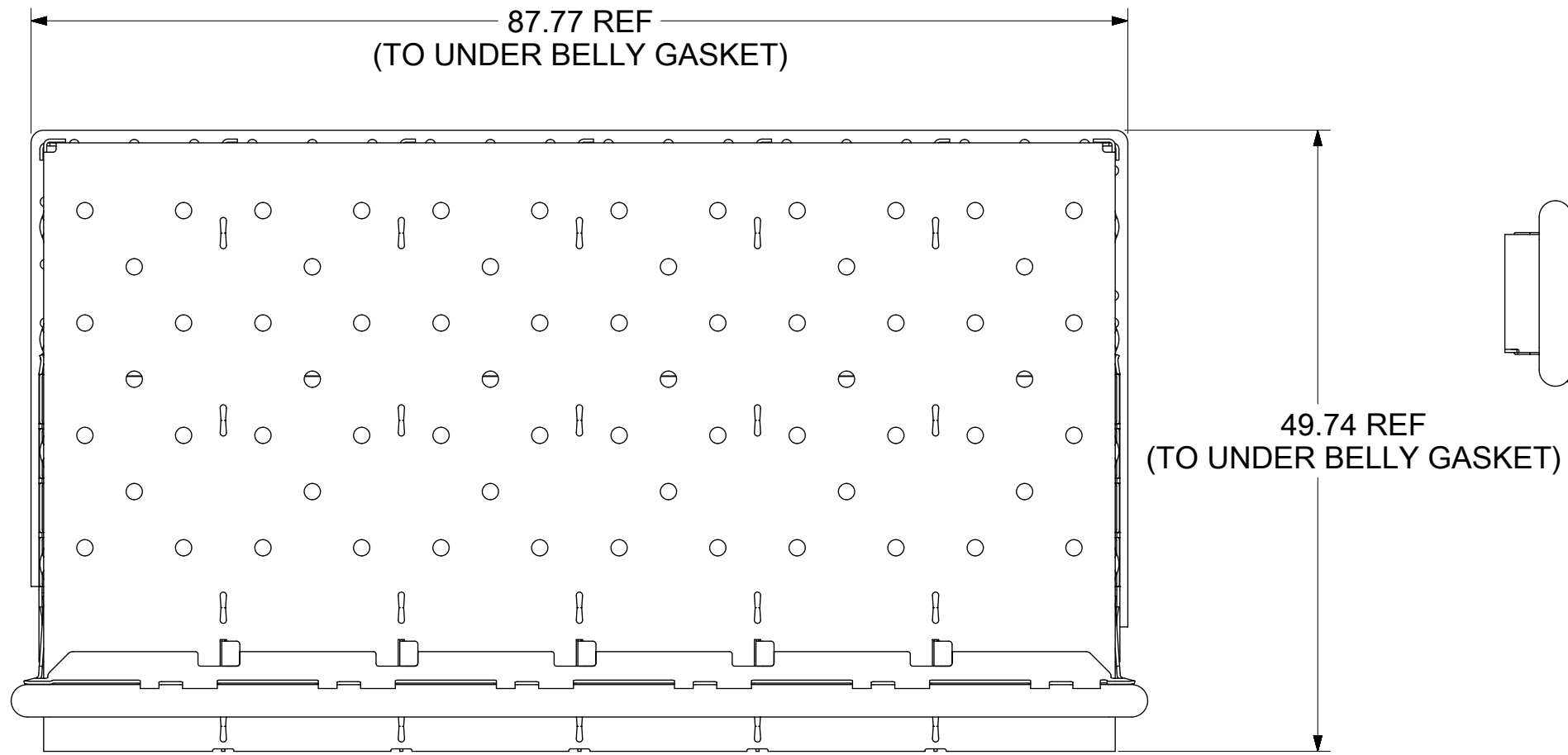

NOTE:
1. CAGE LEG STANDOFF WILL PIERCE GASKET WHEN PROPERLY PRESSED INTO PCB

THIS DRAWING CONTAINS INFORMATION THAT IS PROPRIETARY TO MOLEX ELECTRONIC TECHNOLOGIES, LLC AND SHOULD NOT BE USED WITHOUT WRITTEN PERMISSION

SEE REVISION TABLE EC NO: 116175 DRWN: MHANUMAPPARE CHKD: DSUN15 REV: APPR: RCHEN08	2017/02/27	2017/04/27	2017/05/03	GENERAL TOLERANCES (UNLESS SPECIFIED) ANGULAR TOL ± 1.0 ° 4 PLACES ± 3 PLACES ± 2 PLACES ± 0.13 1 PLACE ± 0.25 0 PLACES ± DRAFT WHERE APPLICABLE MUST REMAIN WITHIN DIMENSIONS	DIMENSION UNITS	SCALE	<p>1X6 SFP+ CAGE.120 INCH PRESS FIT, HEAT SINK, ELASTOMERIC GASKET</p> <p>PRODUCT CUSTOMER DRAWING</p>		
	MHANUMAPPARE	DSUN15	RCHEN08		MM	2:1		SERIES	
	DATE	DATE	DATE		DRWN BY	DATE		DATE	MATERIAL NUMBER
	MHANUMAPPARE	2017/02/27	DSUN15		2017/04/27	111112		SEE SHEET 4	CUSTOMER
	2017/05/03	RCHEN08	2017/05/03		C	THIRD ANGLE PROJECTION		1111122610	PSD
E	REV	APPR	DATE	DATE	DATE	DOC TYPE	DOC PART	SHEET NUMBER	
							ASY	3 OF 9	

PART NUMBER SELECTION

1111120610
SHOWN

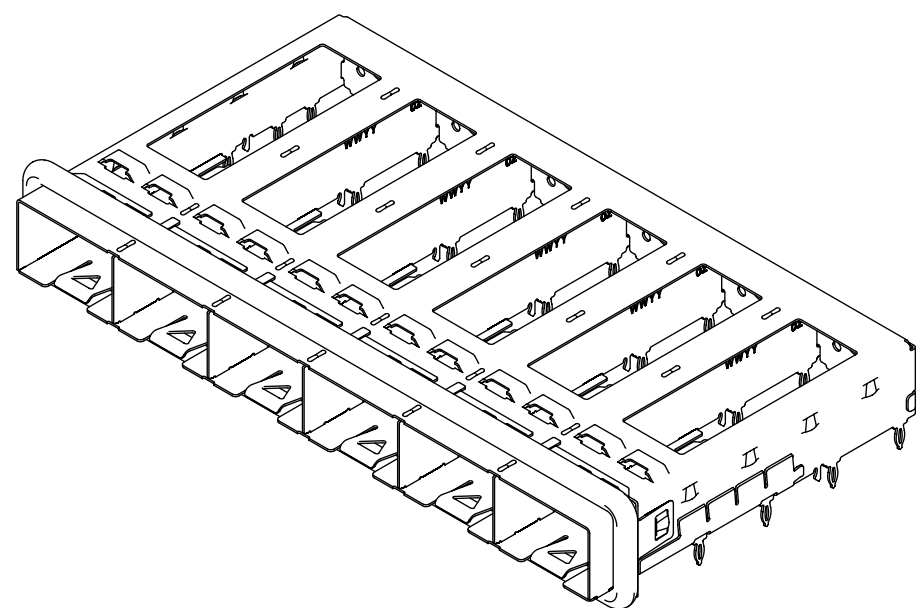

SFP+ OPEN TOP BASE CAGE FOR HEATSINKS			
PART NO.	POLYIMIDE INSOLATOR	HEATSINK	# OF REAR LEGS PER PORT
1111120610	---	---	1A, 1B
1111120650	YES	---	1A, 1B

NOTE: PCI - 13 ROWS
SAN - 11 ROWS
NETWORKING - 10 ROWS

1111122610
SHOWN

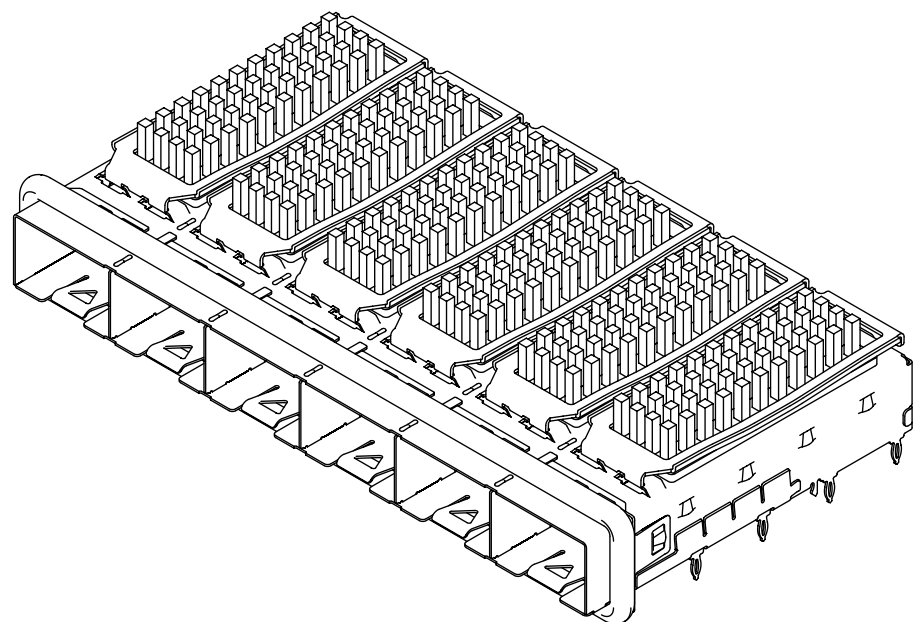

SFP+ PIN FIELD HEATSINK OPTION			
PART NO.	POLYIMIDE INSOLATOR	HEATSINK	# OF REAR LEGS PER PORT
1111121610	---	PCI	1A, 1B
1111121650	YES	PCI	1A, 1B
1111122610	---	SAN	1A, 1B
1111122650	YES	SAN	1A, 1B
1111123610	---	NET	1A, 1B
1111123650	YES	NET	1A, 1B

1111125610
SHOWN

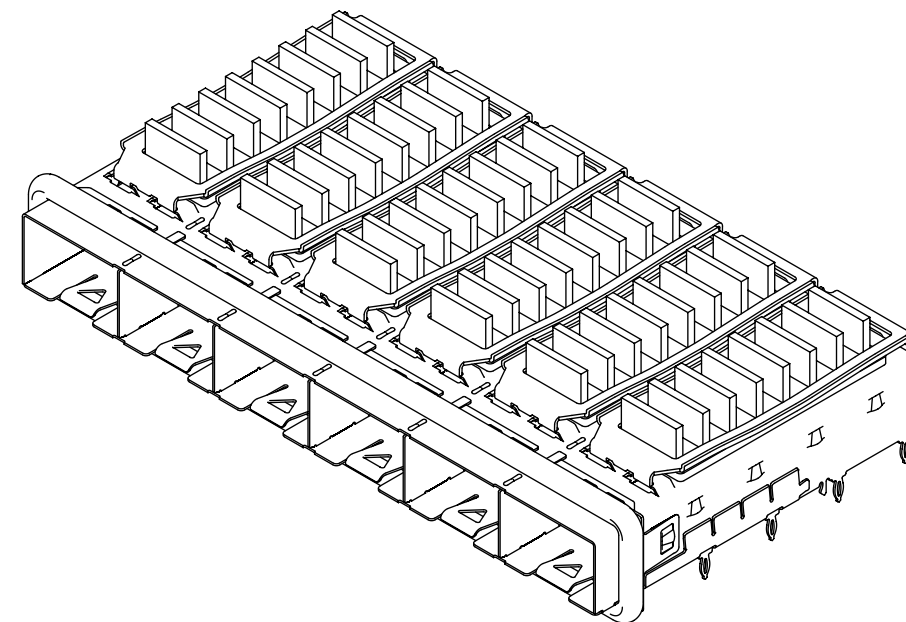

SFP+ LATERAL FIN HEATSINK OPTION			
PART NO.	POLYIMIDE INSOLATOR	HEATSINK	# OF REAR LEGS PER PORT
1111124610	---	PCI	1A, 1B
1111124650	YES	PCI	1A, 1B
1111125610	---	SAN	1A, 1B
1111125650	YES	SAN	1A, 1B
1111126610	---	NET	1A, 1B
1111126650	YES	NET	1A, 1B

1111128610
SHOWN

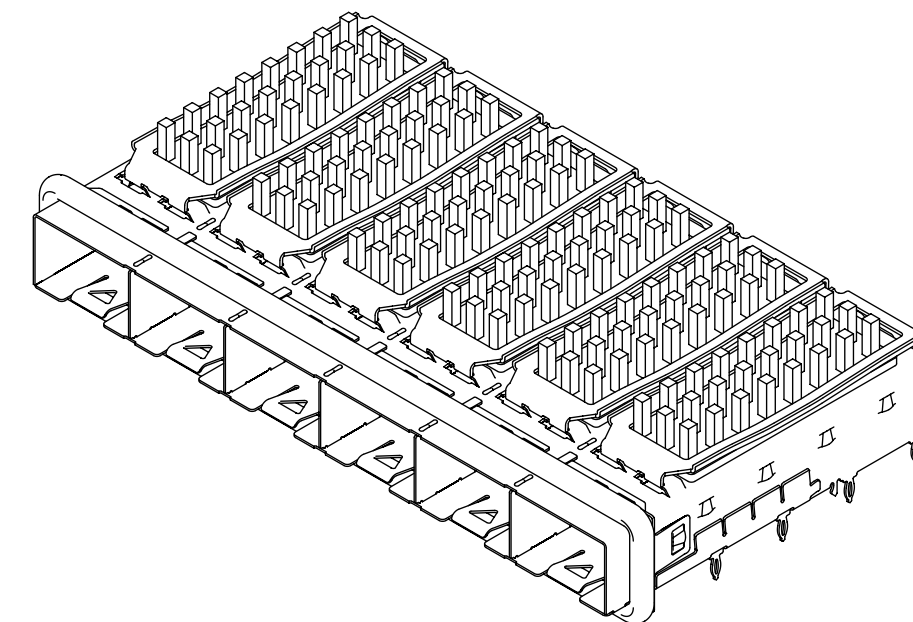

SFP+ WIDE GAP PIN FIELD HEATSINK OPTION			
PART NO.	POLYIMIDE INSOLATOR	HEATSINK	# OF REAR LEGS PER PORT
1111127610	---	PCI	1A, 1B
1111127650	YES	PCI	1A, 1B
1111128610	---	SAN	1A, 1B
1111128650	YES	SAN	1A, 1B
1111129610	---	NET	1A, 1B
1111129650	YES	NET	1A, 1B

747540610
SHOWN

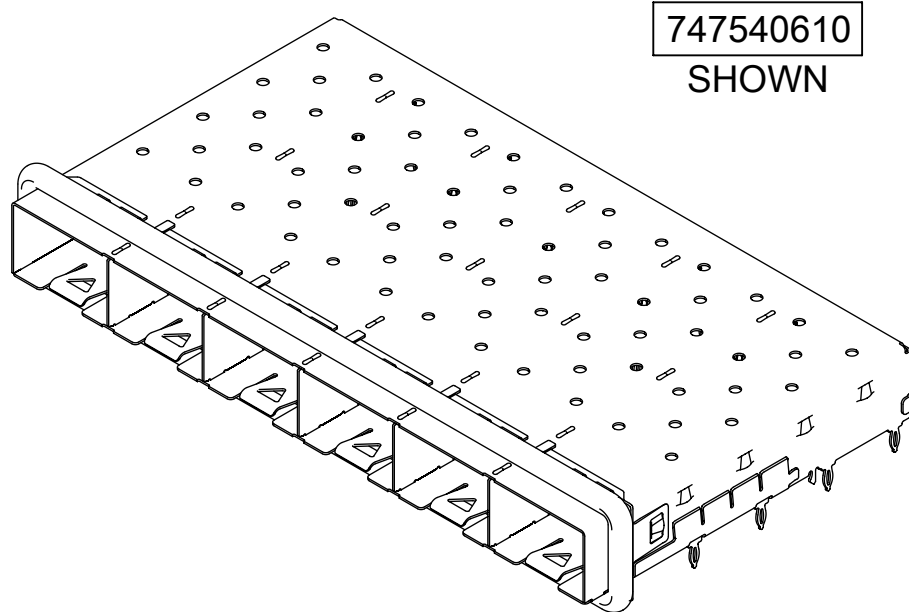

SFP+ CLOSED TOP CAGE			
PART NO.	POLYIMIDE INSOLATOR	HEATSINK	# OF REAR LEGS PER PORT
747540610	---	---	1A, 1B
747540611	---	---	3A
747540613	---	---	1A, 1B

1001150610
SHOWN

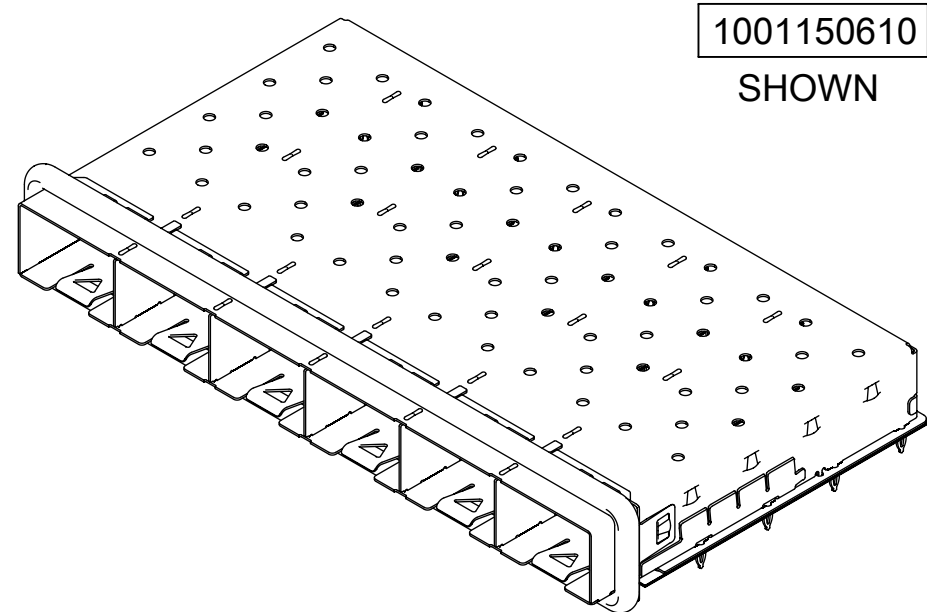

zSFP+ GEN 2 CLOSED TOP BASE CAGE			
PART NO.	POLYIMIDE INSOLATOR	HEATSINK	# OF REAR LEGS PER PORT
1001150610	---	---	1A, 1B

THIS DRAWING CONTAINS INFORMATION THAT IS PROPRIETARY TO MOLEX ELECTRONIC TECHNOLOGIES, LLC AND SHOULD NOT BE USED WITHOUT WRITTEN PERMISSION

SEE REVISION TABLE EC NO: 116175 DRWN: MHANUMAPPARE CHKD: DSUN15 REV / APPR: RCHEN08	2017/02/27	GENERAL TOLERANCES (UNLESS SPECIFIED) ANGULAR TOL ± 1.0 ° 4 PLACES ± 3 PLACES ± 2 PLACES ± 0.13 1 PLACE ± 0.25 0 PLACES ± DRAFT WHERE APPLICABLE MUST REMAIN WITHIN DIMENSIONS	DIMENSION UNITS	SCALE	<p>1X6 SFP+ CAGE. 120 INCH PRESS FIT, HEAT SINK, ELASTOMERIC GASKET</p> <p>PRODUCT CUSTOMER DRAWING</p>
	2017/04/27		MM	1.25:1	
	2017/05/03		DRWN BY	DATE	
			MHANUMAPPARE	2017/02/27	
			CHKD BY	DATE	
	DSUN15	2017/04/27			
	APPR BY	DATE	SERIES		CUSTOMER
	RCHEN08	2017/05/03	111112	SEE TABLE	GENERAL MARKET
	DRAWING SIZE	THIRD ANGLE PROJECTION	DOCUMENT NUMBER		SHEET NUMBER
	C		1111122610		4 OF 9
			PSD	DOC PART	DOC TYPE
				ASY	

PCB LAYOUT FOR SINGLE SIDE MOUNT

HOST CONNECTOR DETAIL

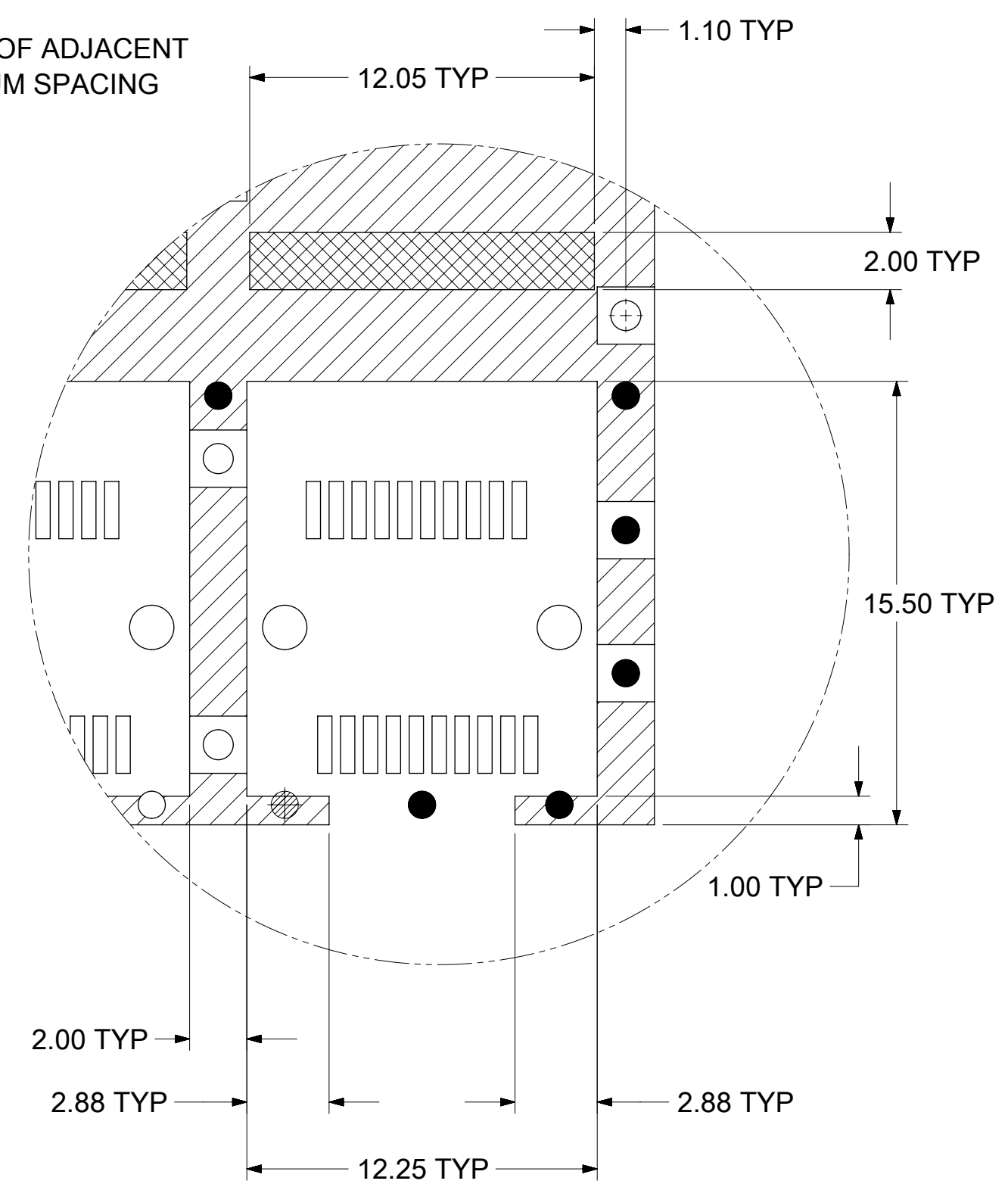
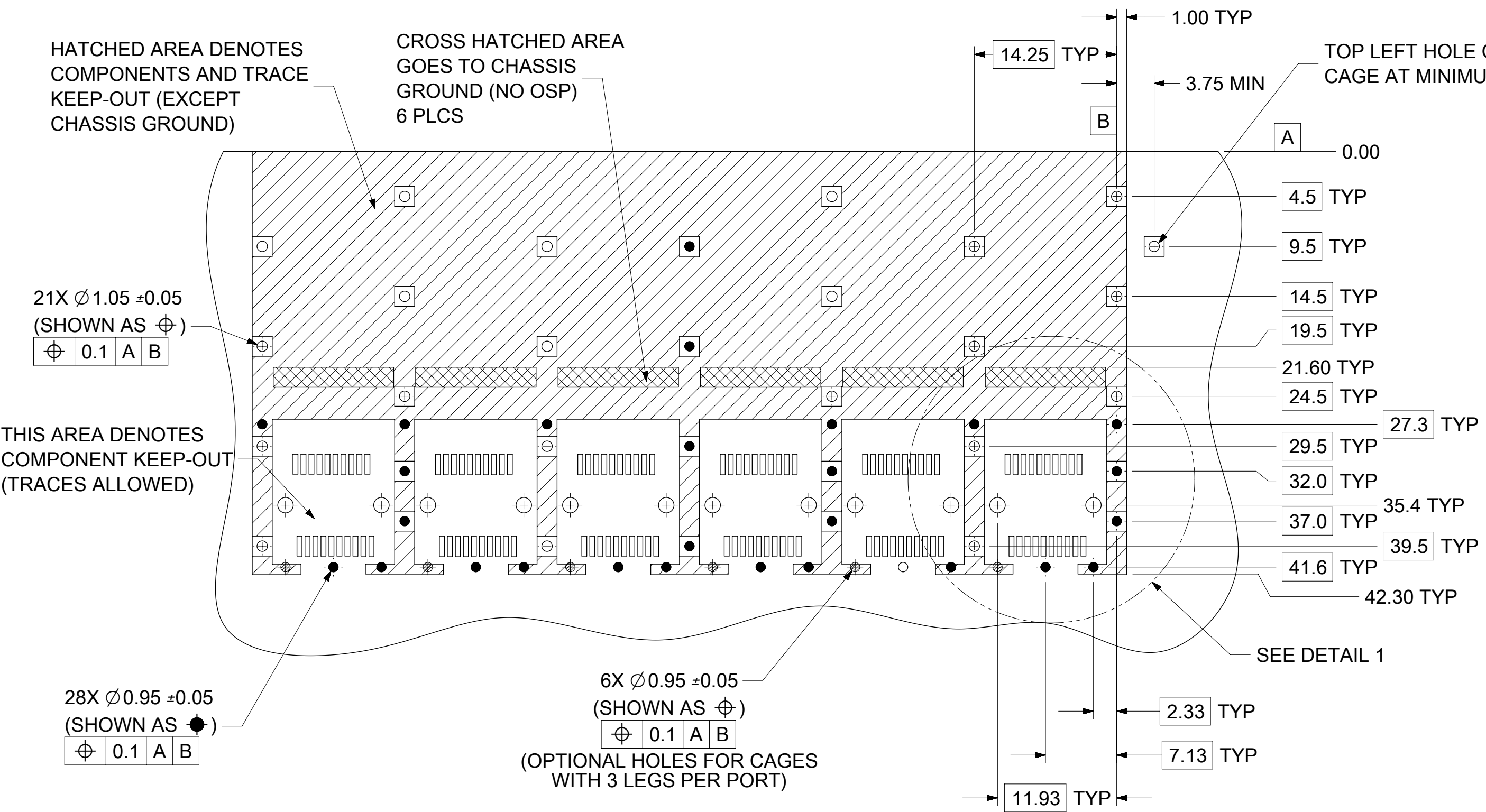

DETAIL 1
SCALE 5:1

- NOTES:
- PADS AND VIAS CONNECT TO CHASSIS GROUND (RECOMMEND PADS TO BE 2.00mm SQUARE)
 - RECOMMENDED THRU HOLE PLATING INCLUDES HASL, OSP, OR IMMERSION (GOLD, SILVER, OR TIN).
 - CONNECTOR PAD LAYOUT PER SFP+ MSA WILL ACCOMMODATE MOLEX CONNECTOR SERIES 74441 OR EQUIVALENT.
 - HOLE PATTERN REPEATS FOR EACH PORT. SPACING BETWEEN PORTS IS 14.25mm.
 - MIN PCB THICKNESS FOR SINGLE SIDED USE: 1.57mm.

THIS DRAWING CONTAINS INFORMATION THAT IS PROPRIETARY TO MOLEX ELECTRONIC TECHNOLOGIES, LLC AND SHOULD NOT BE USED WITHOUT WRITTEN PERMISSION											
SEE REVISION TABLE	EC NO:	116175	GENERAL TOLERANCES (UNLESS SPECIFIED)	DIMENSION UNITS	SCALE	molex					
	DRWN:	MHANUMAPPARE	ANGULAR TOL $\pm 1.0^\circ$	MM	2.5:1						
	CHKD:	DSUN15	4 PLACES \pm	DRWN BY	DATE	1X6 SFP+ CAGE.120 INCH PRESS FIT, HEAT SINK, ELASTOMERIC GASKET					
	REV:	APPR: RCHEN08	3 PLACES \pm	MHANUMAPPARE	2017/02/27	PRODUCT CUSTOMER DRAWING					
			2 PLACES ± 0.13	DSUN15	2017/04/27	SERIES MATERIAL NUMBER CUSTOMER					
		1 PLACE ± 0.25	RCHEN08	2017/05/03	111112 SEE SHEET 4 GENERAL MARKET						
		0 PLACES \pm	DRAFT WHERE APPLICABLE MUST REMAIN WITHIN DIMENSIONS		DRAWING SIZE	THIRD ANGLE PROJECTION	DOCUMENT NUMBER		DOC TYPE	DOC PART	SHEET NUMBER
					C		111122610		PSD	ASY	5 OF 9

PCB LAYOUT FOR BELLY TO BELLY MOUNTING

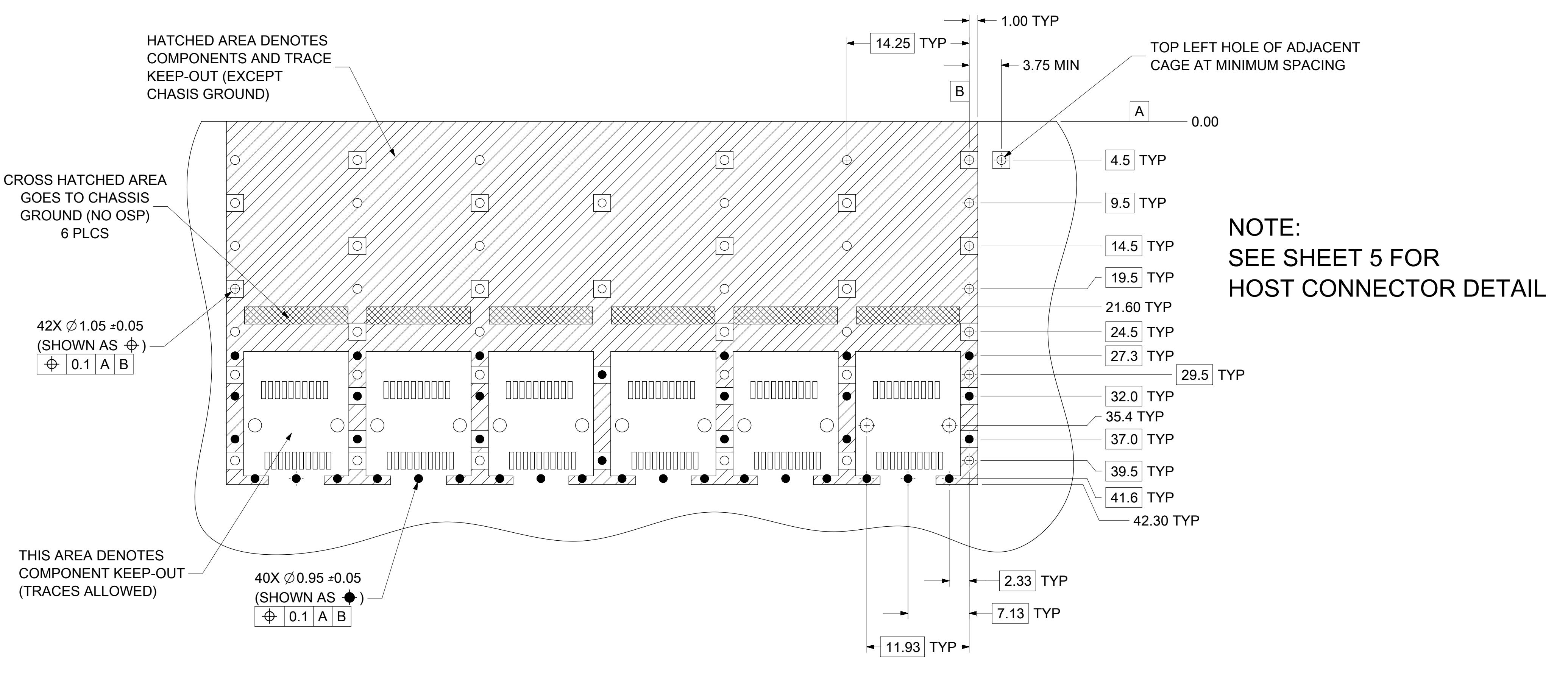

NOTE:
SEE SHEET 5 FOR
HOST CONNECTOR DETAIL

- NOTES:**
1. PADS AND VIAS CONNECT TO CHASSIS GROUND (RECOMMEND PADS TO BE 2.00mm SQUARE)
 2. RECOMMENDED THRU HOLE PLATING INCLUDES HASL, OSP, OR IMMERSION (GOLD, SILVER, OR TIN).
 3. CONNECTOR PAD LAYOUT PER SFP+ MSA WILL ACCOMMODATE MOLEX CONNECTOR SERIES 74441 OR EQUIVALENT.
 4. HOLE PATTERN REPEATS FOR EACH PORT. SPACING BETWEEN PORTS IS 14.25mm.
 5. MIN PCB THICKNESS FOR BELLY TO BELLY USE: 3.00mm.

THIS DRAWING CONTAINS INFORMATION THAT IS PROPRIETARY TO MOLEX ELECTRONIC TECHNOLOGIES, LLC AND SHOULD NOT BE USED WITHOUT WRITTEN PERMISSION											
SEE REVISION TABLE	EC NO:	116175	GENERAL TOLERANCES (UNLESS SPECIFIED)	DIMENSION UNITS	SCALE	molex 1X6 SFP+ CAGE. 120 INCH PRESS FIT, HEAT SINK, ELASTOMERIC GASKET					
	DRWN:	MHANUMAPPARE	ANGULAR TOL ± 1.0 °	MM	3:1						
	CHKD:	DSUN15	4 PLACES ±	DRWN BY	DATE	PRODUCT CUSTOMER DRAWING					
	REV:	APPR: RCHEN08	3 PLACES ±	MHANUMAPPARE	2017/02/27	SERIES	MATERIAL NUMBER	CUSTOMER			
			2 PLACES ± 0.13	DSUN15	2017/04/27	111112	SEE SHEET 4	GENERAL MARKET			
		1 PLACE ± 0.25	APPR BY	DATE	DOCUMENT NUMBER						
		0 PLACES ±	RCHEN08	2017/05/03	1111122610						
		DRAFT WHERE APPLICABLE MUST REMAIN WITHIN DIMENSIONS	DRAWING SIZE	THIRD ANGLE PROJECTION	DOC TYPE						
			C		PSD						
					DOC PART						
					ASY						
					SHEET NUMBER						
					6 OF 9						

POLYIMIDE INSULATOR COVERAGE AREA

(APPLIES TO SINGLE SIDED AND BELLY TO BELLY)

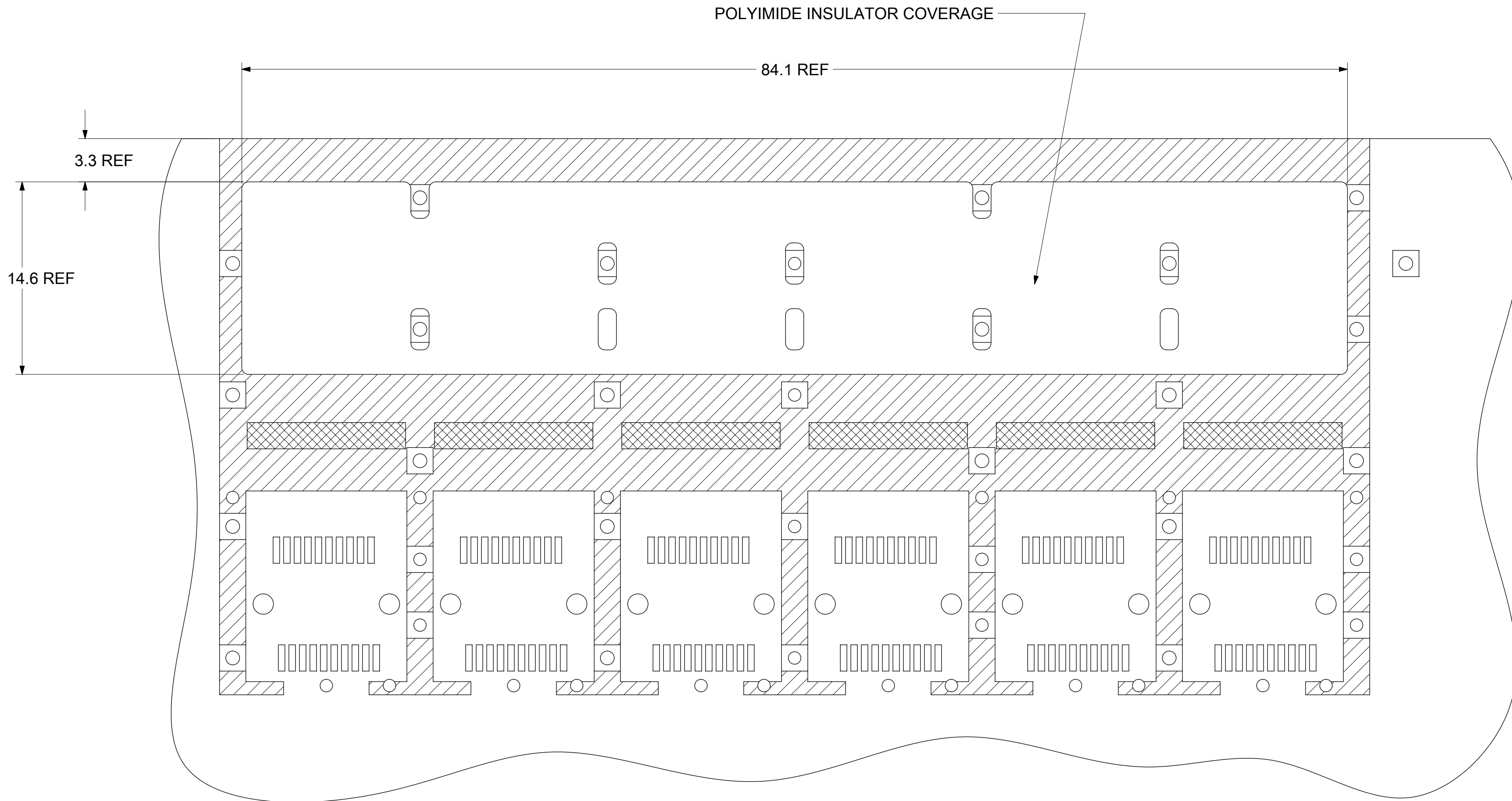

THIS DRAWING CONTAINS INFORMATION THAT IS PROPRIETARY TO MOLEX ELECTRONIC TECHNOLOGIES, LLC AND SHOULD NOT BE USED WITHOUT WRITTEN PERMISSION

SEE REVISION TABLE EC NO: 116175 DRWN: MHANUMAPPARE CHKD: DSUN15 REV / APPR: RCHEN08	GENERAL TOLERANCES (UNLESS SPECIFIED)		DIMENSION UNITS	SCALE	
	ANGULAR TOL ± 1.0 °		MM	4:1	
	4 PLACES ±	DRWN BY	DATE		
	3 PLACES ±	MHANUMAPPARE	2017/02/27		
	2 PLACES ± 0.13	CHKD BY	DATE		
1 PLACE ± 0.25	DSUN15	2017/04/27			
0 PLACES ±	APPR BY	DATE			
	RCHEN08	2017/05/03			
DRAFT WHERE APPLICABLE MUST REMAIN WITHIN DIMENSIONS		DRAWING SIZE	THIRD ANGLE PROJECTION		
		C			
		SERIES	MATERIAL NUMBER	CUSTOMER	
		111112	SEE SHEET 4	GENERAL MARKET	
		DOCUMENT NUMBER		DOC TYPE	DOC PART SHEET NUMBER
		1111122610		PSD	ASY 7 OF 9

BEZEL AND BOARD POSITION DIMENSIONS FOR SINGLE SIDE MOUNTING (ELASTOMERIC GASKET)

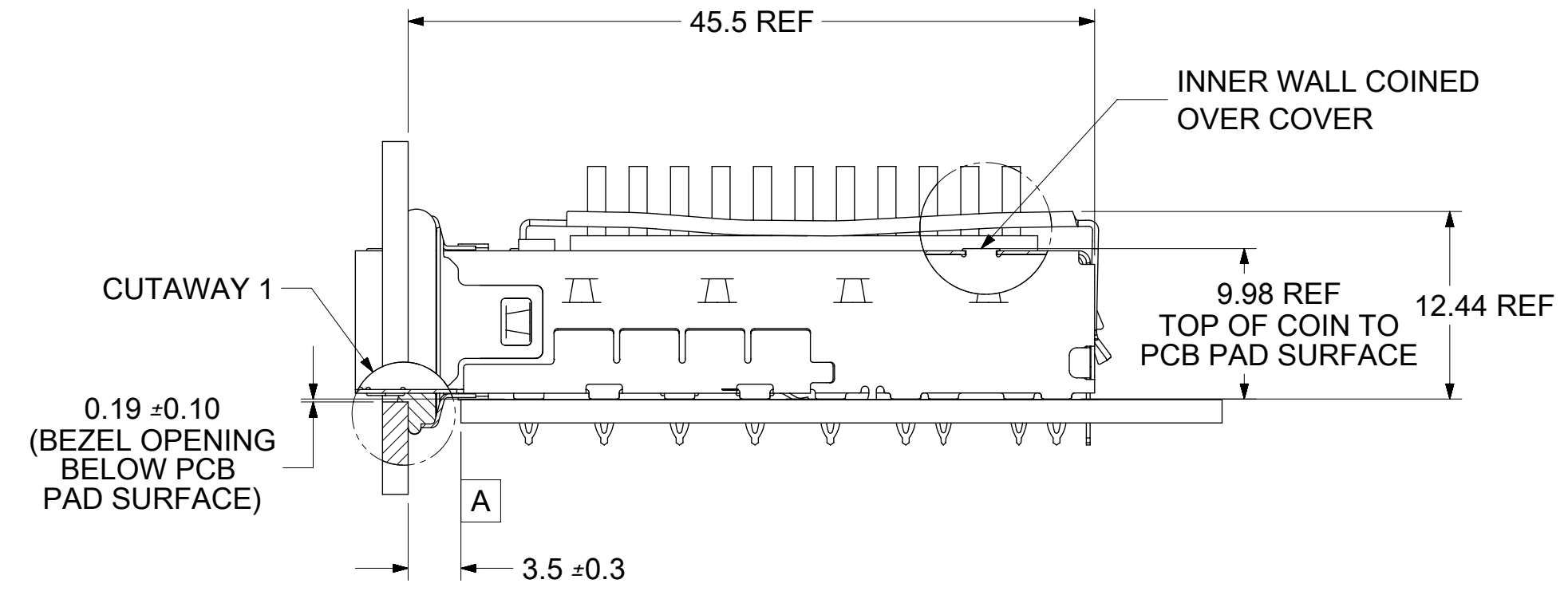
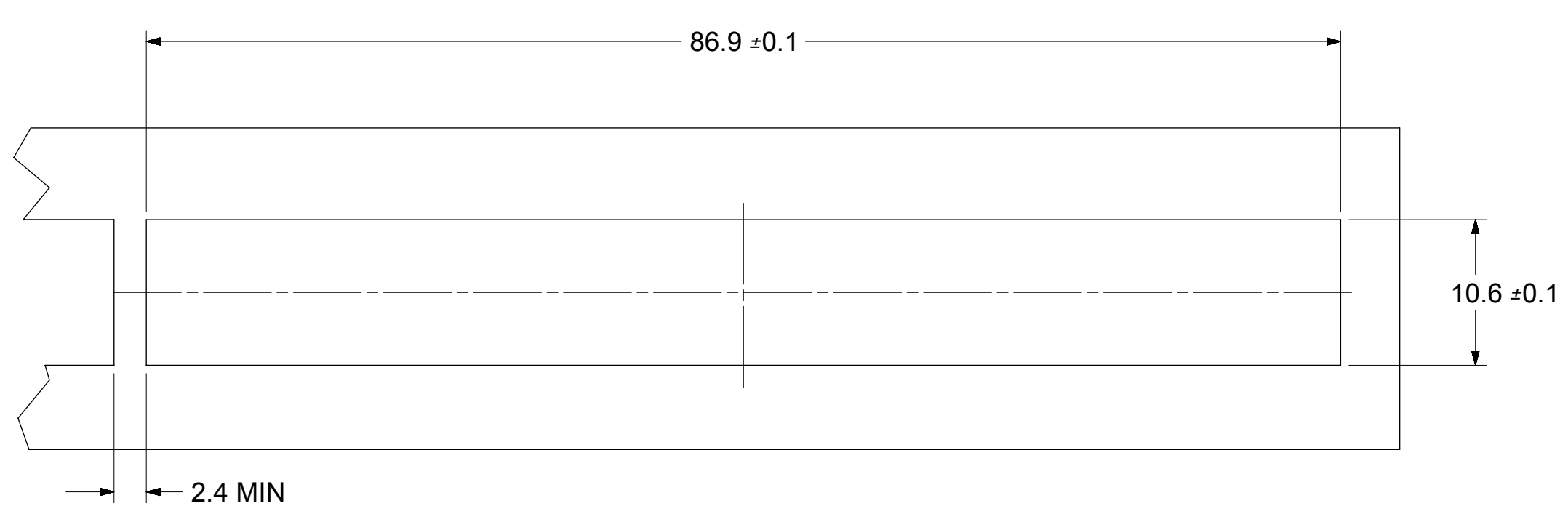

BEZEL AND BOARD POSITION DIMENSIONS FOR BELLY TO BELLY MOUNTING (ELASTOMERIC GASKET)

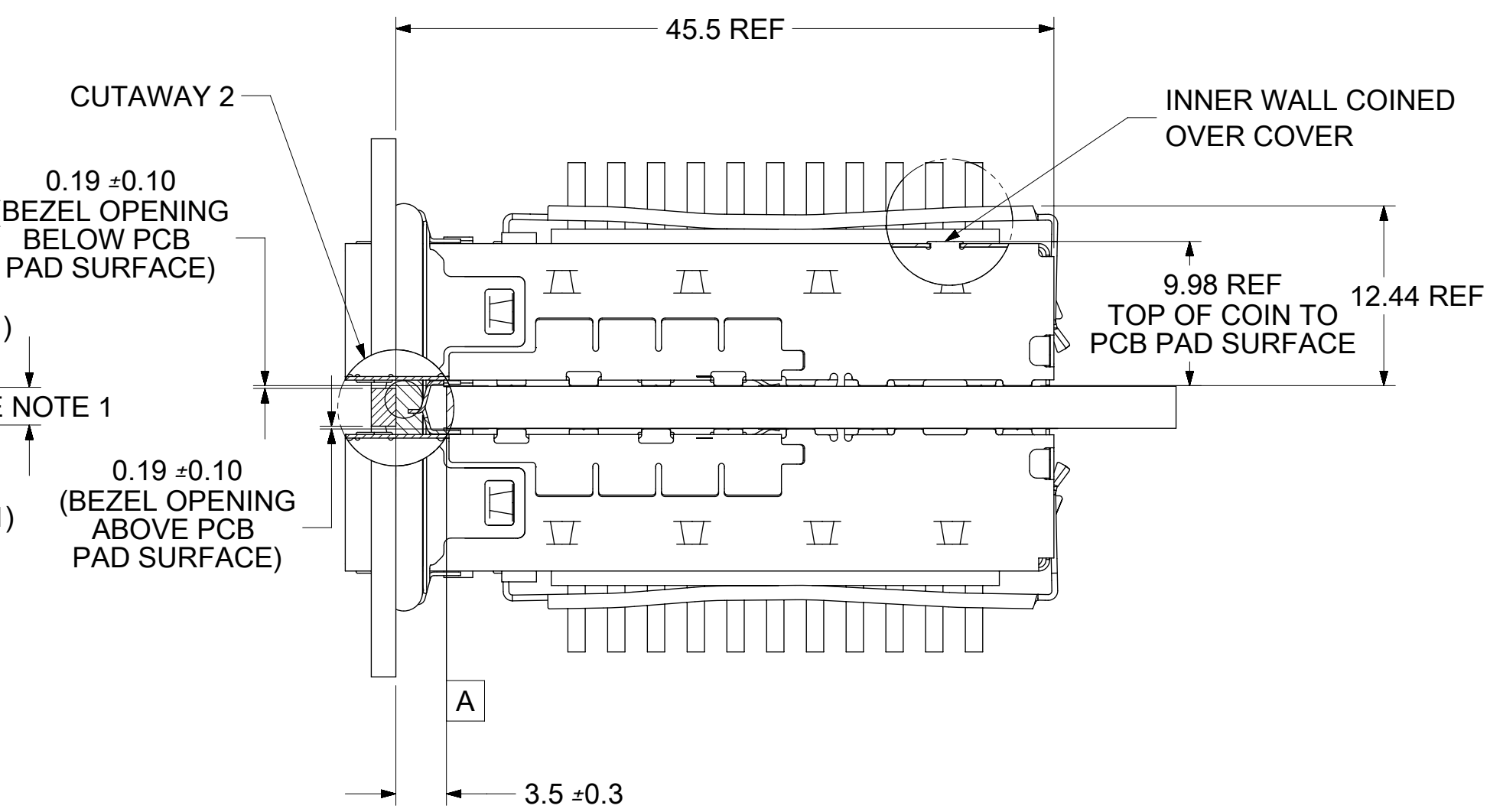
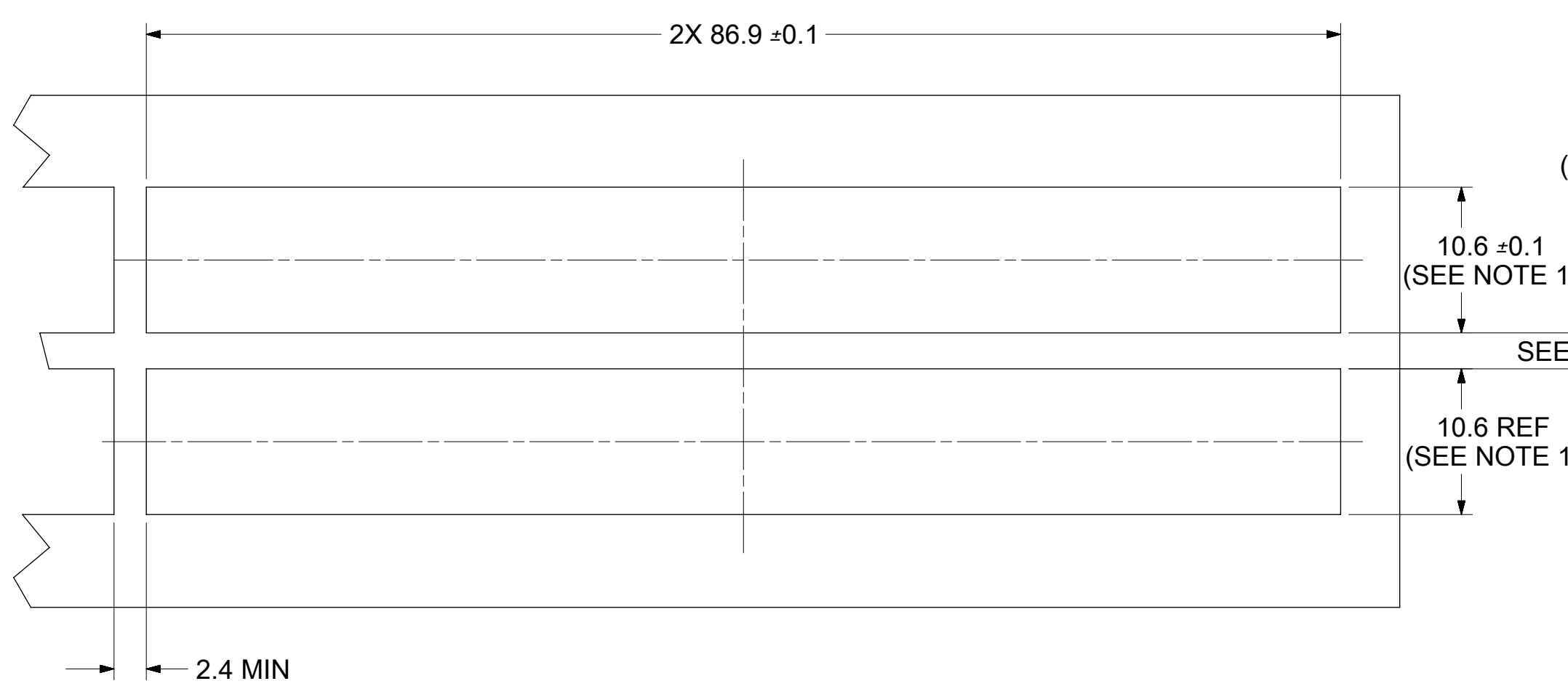

NOTE:
1. PCB THICKNESS VARIATION MUST BE CONSIDERED WHEN DETERMINING BEZEL OPENING LOCATION.

THIS DRAWING CONTAINS INFORMATION THAT IS PROPRIETARY TO MOLEX ELECTRONIC TECHNOLOGIES, LLC AND SHOULD NOT BE USED WITHOUT WRITTEN PERMISSION

SEE REVISION TABLE EC NO: 116175 DRWN: MHANUMAPPARE CHKD: DSUN15 REV: APPR: RCHEN08	GENERAL TOLERANCES (UNLESS SPECIFIED) ANGULAR TOL ± 1.0 ° 4 PLACES ± 3 PLACES ± 2 PLACES ± 0.13 1 PLACE ± 0.25 0 PLACES ±	DIMENSION UNITS MM	SCALE 2.5:1	<p style="margin: 0;">1X6 SFP+ CAGE.120 INCH PRESS FIT, HEAT SINK, ELASTOMERIC GASKET</p>	
	DRWN BY MHANUMAPPARE	DATE 2017/02/27	DRWN BY MHANUMAPPARE		DATE 2017/02/27
	CHKD BY DSUN15	DATE 2017/04/27	CHKD BY DSUN15		DATE 2017/04/27
	APPR BY RCHEN08	DATE 2017/05/03	APPR BY RCHEN08		DATE 2017/05/03
DRAFT WHERE APPLICABLE MUST REMAIN WITHIN DIMENSIONS		DRAWING SIZE C	THIRD ANGLE PROJECTION	SERIES 111112	
		MATERIAL NUMBER SEE SHEET 4		CUSTOMER GENERAL MARKET	
		DOCUMENT NUMBER 1111122610	DOC TYPE PSD	DOC PART ASY	
		SHEET NUMBER 8 OF 9			

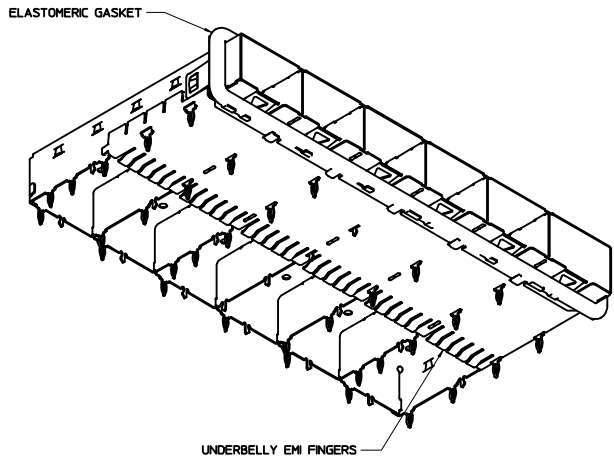
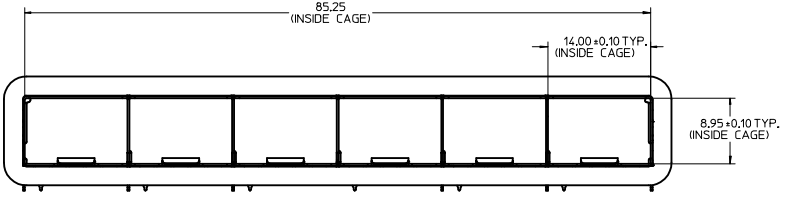
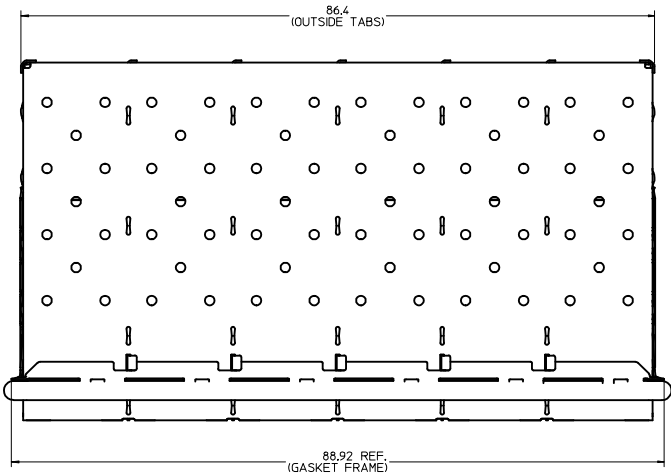

INNER WALLS ARE CONED OVER BASE AND COVER FOR EXCELLENT RIGIDITY

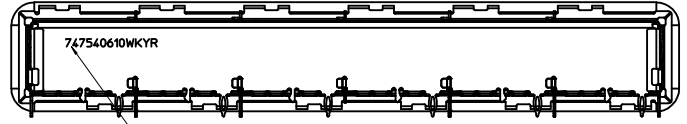
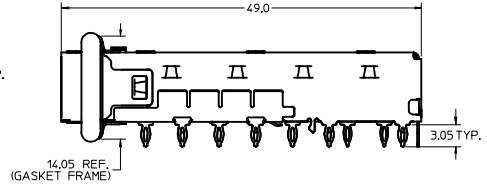
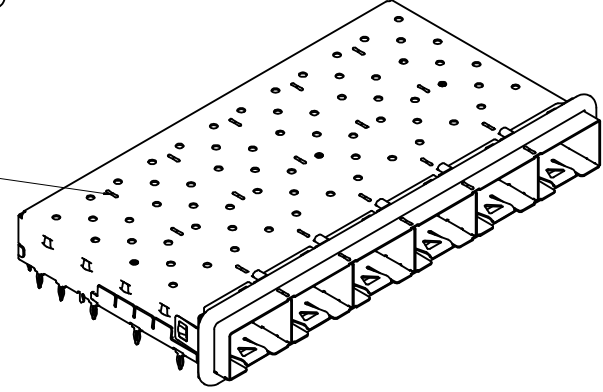

PART NO. AND WEEK/YEAR DATE CODE TO BE PRINTED ON BACK OF CAGE APPROXIMATELY AS SHOWN. SEE TABLE BELOW FOR DATE CODE INFORMATION.

WEEK/YEAR DATE CODE TABLE		
WEEK - 01 THRU 52	EXAMPLE: 01 - FIRST WEEK OF YEAR	52 - LAST WEEK OF YEAR
YEAR - 08 OR 09, ETC.	EXAMPLE: 2008 - YEAR 08	

NOTES:

- MATERIAL:**
CAGE: NICKEL PLATED COPPER ALLOY, THICKNESS 0.25mm
SPRING FINGER: NICKEL PLATED COPPER ALLOY, THICKNESS 0.10mm
- PRESS FIT LEGS 3.05 LONG -**
1.57 MINIMUM PCB THICKNESS FOR SINGLE SIDED USE
3.00 MINIMUM PCB THICKNESS FOR BELLY TO BELLY USE
- OPTIONAL LIGHT PIPE ASSEMBLY AVAILABLE**
- PORTS ARE DESIGNED FOR SFP+ TRANSCEIVERS AND ARE COMPATIBLE WITH SFP TRANSCEIVERS**
- THIS PART MEETS THE RESTRICTION OF HAZARDOUS SUBSTANCES IN ELECTRICAL AND ELECTRONIC EQUIPMENT (ROHS) DIRECTIVE (2002/95/EC)**

REVISED IEC NO. USY2011-0268 DRAWN BY: M. INSKI 2010/10/19 CHYK: APPR: K. JANOTA 2010/10/21 REV DESCRIPTION	QUALITY SYMBOLS	GENERAL TOLERANCES (UNLESS SPECIFIED)	DIMENSION STYLE	SCALE	DESIGN UNITS	THIRD ANGLE PROJECTION
	▽=0 ▽=0	mm INCH 4 PLACES ± --- ± --- 3 PLACES ± --- ± --- 2 PLACES ± 0.15 ± --- 1 PLACE ± 0.25 ± --- ANGULAR ± 1°	MM ONLY	3:1	METRIC	DRAWN BY: CHIRSCHY 2007/05/04 CHECKED BY: BRUSSELL 2007/05/04 APPROVED BY: K. JANOTA 2010/10/21 MATERIAL NO. 747540610 DOCUMENT NO. SD-74754-0610
	DRAFT WHERE APPLICABLE MUST REMAIN WITHIN DIMENSIONS		MOLEX INCORPORATED MOLEX INCORPORATED		SHEET NO. 1 OF 4	

PCB LAYOUT FOR SINGLE SIDE MOUNT

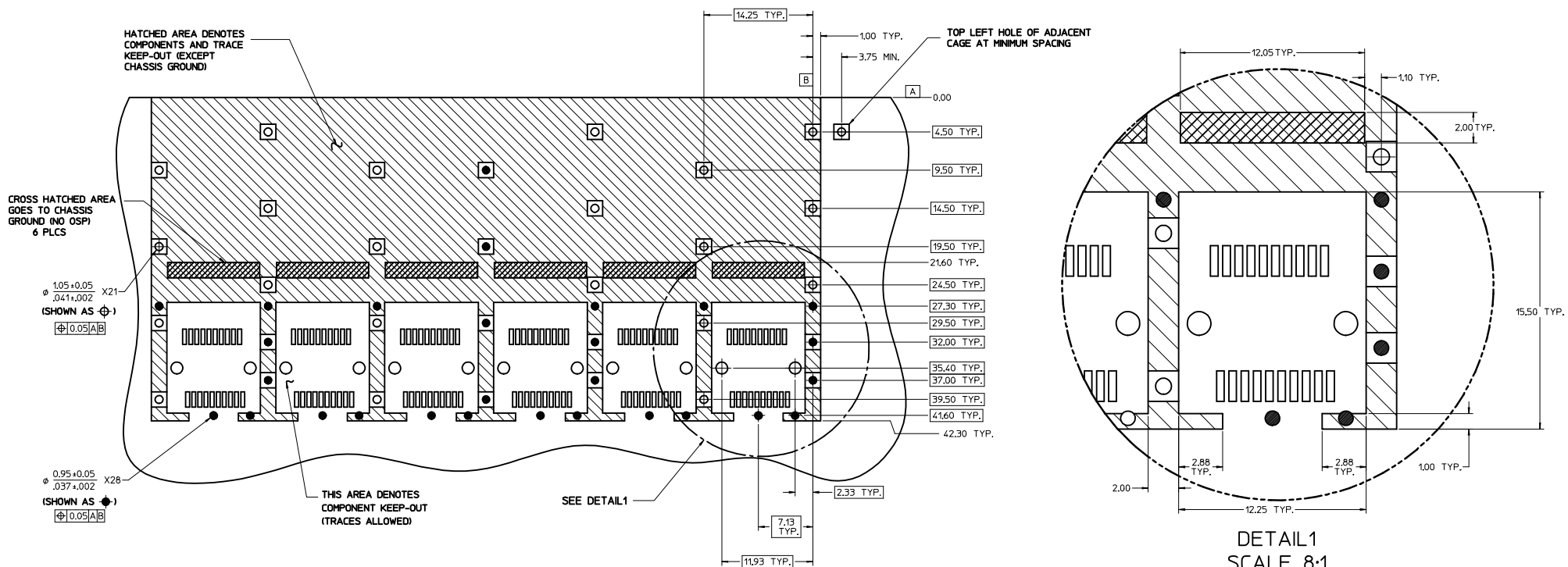

DETAIL1
SCALE 8:1
HOST CONNECTOR DETAIL

- NOTES:**
1. PADS AND VIAS CONNECT TO CHASSIS GROUND (RECOMMEND PADS TO BE 2.00mm SQUARE)
 2. RECOMMENDED THRU HOLE PLATING INCLUDES HASL, OSP, OR IMMERSION (GOLD, SILVER, OR TIN).
 3. CONNECTOR PAD LAYOUT PER SFP+ MSA WILL ACCOMMODATE MOLEX CONNECTOR SERIES 74441 OR EQUIVALENT.
 4. HOLE PATTERN REPEATS FOR EACH PORT. SPACING BETWEEN PORTS IS 14.25mm.

REVISED EEC NO. USY2011-0268 DRAWN BY: MIKILINSKI 2010/10/19 CHYK: APPR: KJANOTA 2010/10/21 REV DESCRIPTION	QUALITY SYMBOLS ▽=0 ▽=0		GENERAL TOLERANCES (UNLESS SPECIFIED) mm INCH 4 PLACES ± --- ± --- 3 PLACES ± --- ± --- 2 PLACES ± 0.15 ± --- 1 PLACE ± 0.25 ± --- ANGULAR ± 1°		DIMENSION STYLE MM ONLY SCALE 4:1 DESIGN UNITS METRIC THIRD ANGLE PROJECTION	
	DRAWN BY DATE CHIRSCHY 2007/05/04 CHECKED BY DATE BRUSSELL 2007/05/04 APPROVED BY DATE KJANOTA 2010/10/21		TITLE SFP+ 1X6 GANGED CAGE W/ ELASTOMER GASKET		MATERIAL NO. DOCUMENT NO. 747540610 SD-74754-0610	
	DRAFT WHERE APPLICABLE MUST REMAIN WITHIN DIMENSIONS		MOLEX INCORPORATED		SHEET NO. 2 OF 4	
	THIS DRAWING CONTAINS INFORMATION THAT IS PROPRIETARY TO MOLEX INCORPORATED AND SHOULD NOT BE USED WITHOUT WRITTEN PERMISSION					

PCB LAYOUT FOR BELLY TO BELLY MOUNTING

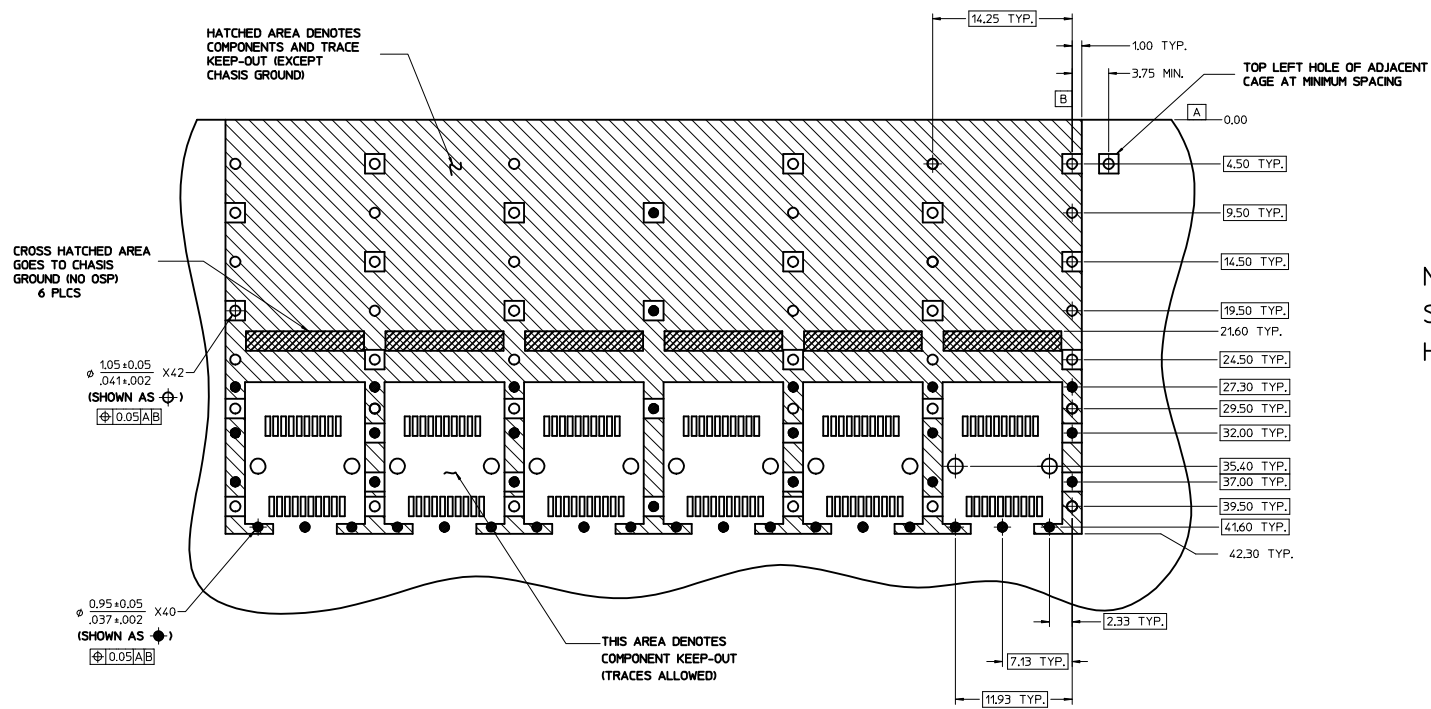

NOTE:
SEE SHEET 2 FOR
HOST CONNECTOR DETAIL

NOTES:

1. PADS AND VIAS CONNECT TO CHASSIS GROUND (RECOMMEND PADS TO BE 2.00mm SQUARE)
2. RECOMMENDED THRU HOLE PLATING INCLUDES HASL, OSP, OR IMMERSION (GOLD, SILVER, OR TIN).
3. CONNECTOR PAD LAYOUT PER SFP+ MSA WILL ACCOMMODATE MOLEX CONNECTOR SERIES 74441 OR EQUIVALENT.
4. HOLE PATTERN REPEATS FOR EACH PORT. SPACING BETWEEN PORTS IS 14.25mm.

REVISED E.C. NO. USY2011-0268 DRAWN BY: INSKI 2010/10/19 CHYK: APPR: KJANOTA 2010/10/21 REV:	QUALITY SYMBOLS	GENERAL TOLERANCES (UNLESS SPECIFIED)	DIMENSION STYLE	SCALE	DESIGN UNITS	THIRD ANGLE PROJECTION
	▽=0 ▽=0	mm INCH 4 PLACES ± --- ± --- 3 PLACES ± --- ± --- 2 PLACES ± 0.15 ± --- 1 PLACE ± 0.25 ± --- ANGULAR ± 1°	MM ONLY 4:1 METRIC	DRAWN BY: CHIRSCY 2007/05/04 CHECKED BY: BRUSSELL 2007/05/04 APPROVED BY: KJANOTA 2010/10/21	TITLE: SFP+ 1X6 GANGED CAGE W/ ELASTOMER GASKET MATERIAL NO. 747540610 DOCUMENT NO. SD-74754-0610	
DRAFT WHERE APPLICABLE MUST REMAIN WITHIN DIMENSIONS		MOLEX INCORPORATED SHEET NO. 3 OF 4				
THIS DRAWING CONTAINS INFORMATION THAT IS PROPRIETARY TO MOLEX INCORPORATED AND SHOULD NOT BE USED WITHOUT WRITTEN PERMISSION						

BEZEL AND BOARD POSITION DIMENSIONS FOR SINGLE SIDE MOUNTING
(GASKET)

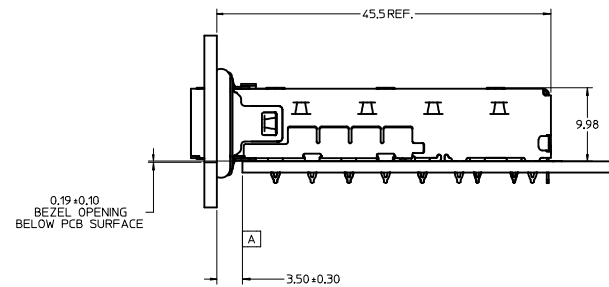
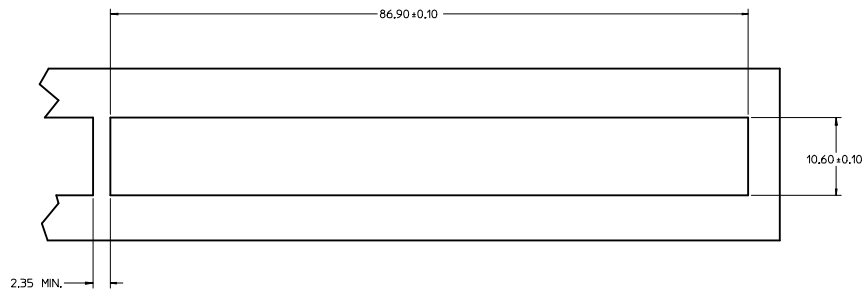

BEZEL AND BOARD POSITION DIMENSIONS FOR BELLY TO BELLY MOUNTING
(GASKET)

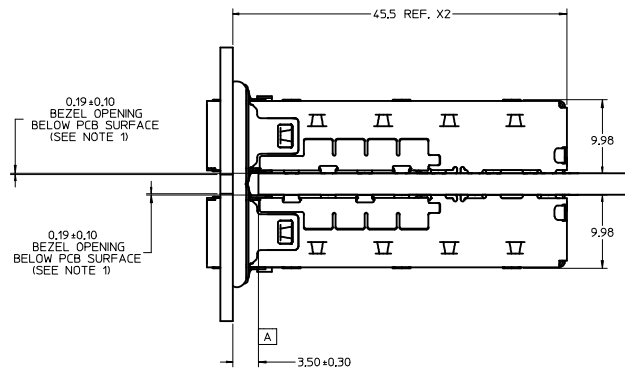
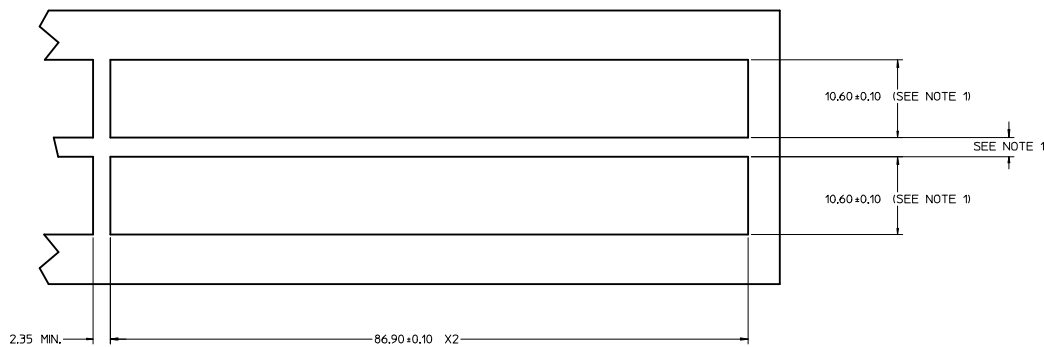

NOTES:

1. PCB THICKNESS VARIATION MUST BE CONSIDERED WHEN DETERMINING BEZEL OPENING, SIZE, AND LOCATION.

REVISED EC NO. USY2011-0268 DRAWN BY: M. INSKI 2010/10/19 CHKD: APPR: K. JANOTA 2010/10/21	QUALITY SYMBOLS	GENERAL TOLERANCES (UNLESS SPECIFIED)	DIMENSION STYLE MM ONLY	SCALE 3:1	DESIGN UNITS METRIC	THIRD ANGLE PROJECTION
	<p>▽=0</p> <p>▽=0</p>	<p>4 PLACES ± mm ± INCH</p> <p>3 PLACES ± --- ± ---</p> <p>2 PLACES ± 0.15 ± ---</p> <p>1 PLACE ± 0.25 ± ---</p> <p>ANGULAR ± 1 °</p>	<p>DRAWN BY: CHIRSCHY 2007/05/04</p> <p>CHECKED BY: BRUSSELL 2007/05/04</p> <p>APPROVED BY: K. JANOTA 2010/10/21</p>	TITLE SFP+ 1X6 GANGED CAGE W/ ELASTOMER GASKET	MATERIAL NO. 747540610	DOCUMENT NO. SD-74754-0610
DRAFT WHERE APPLICABLE MUST REMAIN WITHIN DIMENSIONS		THIS DRAWING CONTAINS INFORMATION THAT IS PROPRIETARY TO MOLEX INCORPORATED AND SHOULD NOT BE USED WITHOUT WRITTEN PERMISSION				

X-ON Electronics

Largest Supplier of Electrical and Electronic Components

Click to view similar products for [Headers & Wire Housings](#) category:

Click to view products by [Molex](#) manufacturer:

Other Similar products are found below :

[57102-F02-18ULF](#) [58102-G61-06LF](#) [582553-1](#) [009176003701906](#) [01.001.5753.1](#) [0050291907](#) [02.125.8002.8](#) [609-3404](#) [61062-3](#)
[CSU011177004](#) [622-0430](#) [622-3653LF](#) [63453-116](#) [636-1030](#) [636-1427](#) [636-3427](#) [636-4007](#) [641938-9](#) [644827-2](#) [65495-038](#) [65692-001LF](#)
[65781-018](#) [65781-047](#) [65817-010LF](#) [65817-015LF](#) [66207-023LF](#) [67095-007LF](#) [67601157](#) [68631-112](#) [68645-018](#) [699319-000](#)
[M90C108951C](#) [70.362.1628.0](#) [70-4210](#) [70-4226B](#) [70-4853B](#) [707-5028](#) [71.350.2428.0](#) [71961-016LF](#) [733-134](#) [733-162](#) [754199-000](#) [760-](#)
[3052](#) [80.063.4001.1](#) [800-90-001-10-001000](#) [800-90-010-10-002000](#) [801-43-002-10-013000](#) [801-43-006-10-002000](#) [803-41-018-10-001000](#)
[803-43-024-10-001000](#)