High Voltage Low Power Consumption LDO

MD7680 Series

CMOS Voltage Regulator With ON/OFF Switch

150mA



MD7680 is a high voltage (up to 60V) ultra-low quiescent current low dropout voltage regulator (LDO) manufactured in CMOS processes. It can deliver up to 150mA of current while consuming only 2.3uA of quiescent current. It consists of a reference voltage generator, an error amplifier, a current foldback circuit, and a phase compensation circuit plus a driver transistor. The MD7680 is designed specifically for applications where very-low I_Q is a critical parameter. This device

maintains low quiescent current consumption even in dropout mode to further increase the battery life. When in shutdown or disabled mode, the device consumes less than 100-nA I_Q even with input voltage of 60V that helps increase the shelf life of the battery.

■ Features

- Ultra-low Quiescent Current: 2.3uA
- Maximum Input Voltage: 60V
- Output Voltage Highly Accurate: $\pm 2\%$
- Maximum Output Current: 150mA
- Dropout Voltage: 8mV@ $I_{OUT}=1mA$
- Temperature Stability: $\pm 40ppm/^{\circ}C$
- ON/OFF Logic = Enable High
- Protections Circuits: Current Limiter, Foldback, Thermal shutdown
- Output Capacitor: Low ESR Ceramic Capacitor Compatible

■ Applications

- Smart wearer
- Long-life battery-powered devices
- Portable mobile devices, such as mobile phones, cameras, and so on
- Wireless communication equipment

■ Typical Applications

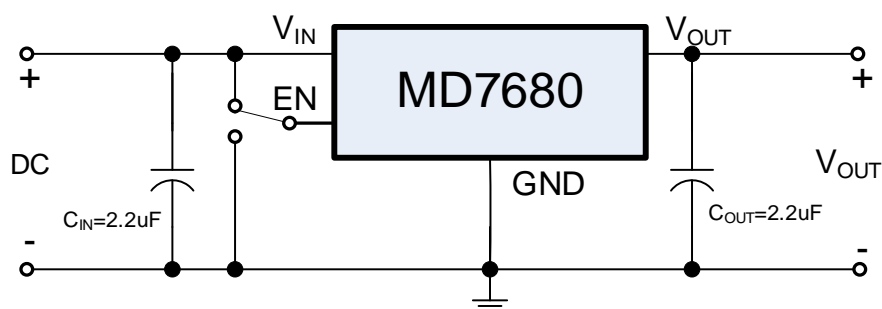

■ Notes on Use

- Input Capacitor (C_{IN}): 2.2uF above
- Output Capacitor (C_{OUT}): 2.2uF above

■ Pin Configuration and Functions

SOT89-3L(A_Type)
Top View

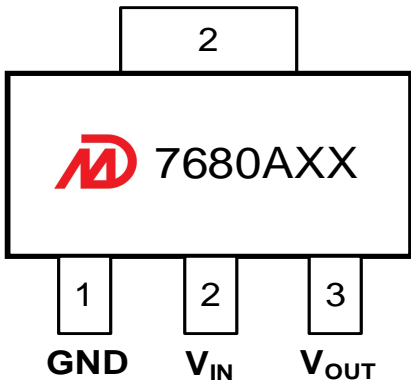

SOT89-3L(E_Type)
Top View

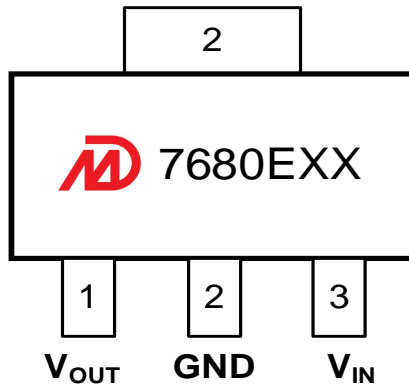

SOT89-5L
Top View

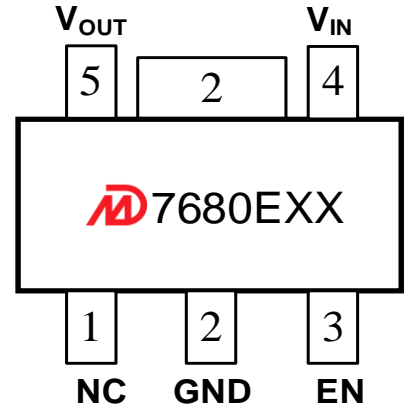

SOT223-3L(F_Type)
Top View

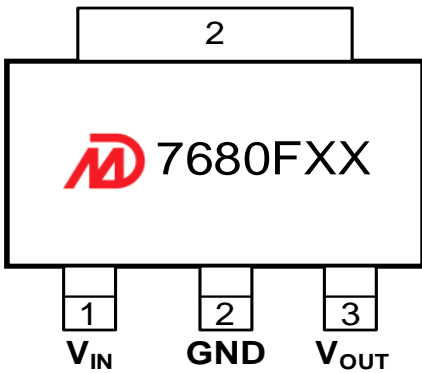

SOT23-5L
Top View

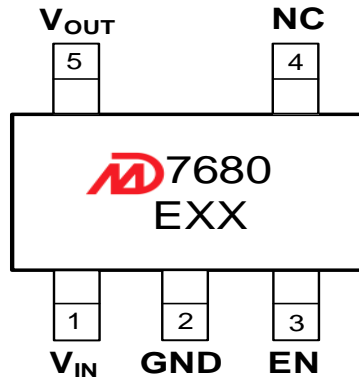

SOT23-3L
Top View

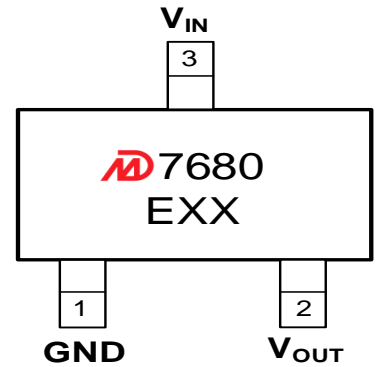

TO252-2L(D_Type)
TOP View

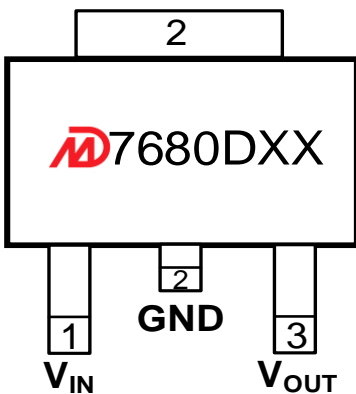

ESOP8(H_Type)
Top View

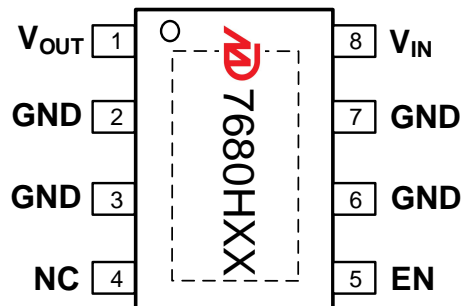



Pin Functions

NAME	DESCRIPTION
V _{IN}	Power Input Pin.
EN	Enable pin. Drive this pin high to enable the device. Drive this pin low to put the device into low current shutdown.
V _{OUT}	Regulated output voltage pin
GND	Ground

Notes: Customer can request to customize other packages with or without EN pin.

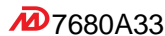
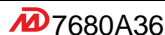
■ Product Selections

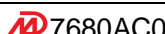
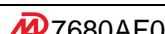
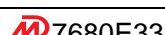
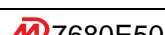
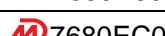
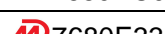
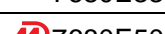
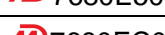
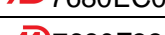
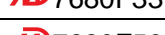
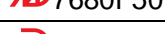
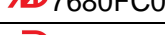
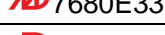
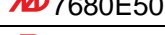
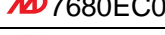
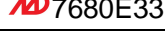
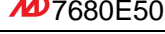
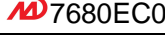
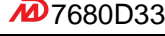
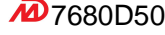
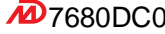
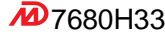
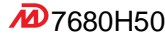
Product Name	V _{OUT} (V)	Package	Ordering Name	Marking	Package Information
MD7680A33	3.3	SOT89-3L	MD7680A33PA1	 7680A33	Tape and Reel, 1000pcs
MD7680A36	3.6	SOT89-3L	MD7680A36PA1	 7680A36	
MD7680A50	5.0	SOT89-3L	MD7680A50PA1	 7680A50	
MD7680AC0	12.0	SOT89-3L	MD7680AC0PA1	 7680AC0	
MD7680AF0	15.0	SOT89-3L	MD7680AF0PA1	 7680AF0	
MD7680E33	3.3	SOT89-3L	MD7680E33PA1	 7680E33	Tape and Reel, 1000pcs
MD7680E50	5.0	SOT89-3L	MD7680E50PA1	 7680E50	
MD7680EC0	12.0	SOT89-3L	MD7680EC0PA1	 7680EC0	
MD7680E33	3.3	SOT89-5L	MD7680E33PC1	 7680E33	Tape and Reel, 1000pcs
MD7680E50	5.0	SOT89-5L	MD7680E50PC1	 7680E50	
MD7680EC0	12.0	SOT89-5L	MD7680EC0PC1	 7680EC0	
MD7680F33	3.3	SOT223-3L	MD7680F33YA2	 7680F33	Tape and Reel, 2500pc
MD7680F50	5.0	SOT223-3L	MD7680F50YA2	 7680F50	
MD7680FC0	12.0	SOT223-3L	MD7680FC0YA2	 7680FC0	
MD7680E33	3.3	SOT23-5L	MD7680E33QC3	 7680E33	Tape and Reel, 3000pc
MD7680E50	5.0	SOT23-5L	MD7680E50QC3	 7680E50	
MD7680EC0	12.0	SOT23-5L	MD7680EC0QC3	 7680EC0	
MD7680E33	3.3	SOT23-3L	MD7680E33QA3	 7680E33	Tape and Reel, 3000pc
MD7680E50	5.0	SOT23-3L	MD7680E50QA3	 7680E50	
MD7680EC0	12.0	SOT23-3L	MD7680EC0QA3	 7680EC0	
MD7680D33	3.3	TO252-2L	MD7680D33UA2	 7680D33	Tape and Reel, 2500pcs
MD7680D50	5.0	TO252-2L	MD7680D50UA2	 7680D50	
MD7680DC0	12.0	TO252-2L	MD7680DC0UA2	 7680DC0	
MD7680H33	3.3	ESOP8	MD7680H33SF4	 7680H33	Tape and Reel, 4000pcs
MD7680H50	5.0	ESOP8	MD7680H50SF4	 7680H50	
MD7680HC0	12.0	ESOP8	MD7680HC0SF4	 7680HC0	

Notes:

1* Customer can request to customize the output voltage ranged from 1.2V to 15V if desired voltage is not found in the selection s.

2* Customer can request customization of package choice.

3* Please pay attention to the MARKING of the product package type.

■ **Absolute Maximum Ratings (Unless otherwise indicated: $T_a=25^\circ\text{C}$)**

PARAMETER	SYMBOL	RATINGS		UNITS
Input Voltage	V_{IN}	-0.3 ~ 65		V
Output Voltage	V_{OUT}	$V_{SS}-0.3 \sim V_{IN}+0.3V$		
Power Dissipation	P_D	ESOP8	1800	mW
		TO252-2L	1800	
		SOT223-3L	1500	
		SOT89-5L	1000	
		SOT89-3L	1000	
		SOT23-5L	250	
		SOT23-3L	250	
Thermal Resistance	$R_{\theta JA}$	ESOP8	80	$^\circ\text{C/W}$
		TO252-2L	55	
		SOT223-3L	66	
		SOT89-5L	100	
		SOT89-3L	100	
		SOT23-5L	250	
		SOT23-3L	250	
Operating Ambient Temperature	T_{opr}	-40 ~ +85		$^\circ\text{C}$
Storage Temperature	T_{stg}	-40 ~ +125		
ESD Protection	ESD HBM	7000		V
Humidity sensitive level	MSL	3		

Note: Stresses above those listed under "Absolute Maximum Ratings" may cause permanent damage to the device.

■ Electrical Characteristics

MD7680 Series (Unless otherwise indicated: $T_a=25^\circ\text{C}$)

PARAMETER	SYMBOL	CONDITIONS	MIN.	TYP.	MAX.	UNIT	
Output Voltage* ¹	$V_{OUT(S)}$	$V_{IN}=V_{OUT(S)}+2V, I_{OUT}=1\text{mA}$	$V_{OUT(S)}\times 0.98$	$V_{OUT(S)}$	$V_{OUT(S)}\times 1.02$	V	
Dropout Voltage* ²	V_{DROP}	$V_{EN}=V_{IN}, V_{OUT(S)}=5.0V$ $I_{OUT}=1\text{mA}$		8	16	mV	
		$V_{EN}=V_{IN}, V_{OUT(S)}=5.0V$ $I_{OUT}=150\text{mA}$		1300	1800		
Line Regulation	$\frac{\Delta V_{OUT}}{\Delta V_{IN} \cdot V_{OUT(S)}}$	$V_{OUT(S)}+2V \leq V_{IN} \leq 60V$ $I_{OUT}=1\text{mA}$		0.01	0.02	%/V	
Load Regulation	ΔV_{OUT2}	$V_{IN}=V_{OUT(S)}+2V$ $1\text{mA} \leq I_{OUT} \leq 150\text{mA}$	$V_{OUT(S)} \leq 5.3V$	20	40	mV	
			$V_{OUT(S)} > 5.3V$	50	80		
Temperature Stability	$\frac{\Delta V_{OUT}}{\Delta T_a \cdot V_{OUT(S)}}$	$V_{IN}=V_{OUT(S)}+2V, I_{OUT}=10\text{mA}$ $-40^\circ\text{C} \leq T_a \leq 125^\circ\text{C}$		± 40		ppm/ $^\circ\text{C}$	
GND Current ($V_{EN}=V_{IN}$)	I_{GND}	no load ($V_{OUT(S)}+2V \leq V_{IN} \leq 55V$)	$V_{OUT(S)} < 3.0V$	0.8	1.2	2.5	uA
			$3.0V \leq V_{OUT(S)} \leq 5.3V$	1	2.3	3	
			$V_{OUT(S)} > 5.3V$	1.5	3	4.5	
		no load ($55V < V_{IN} \leq 60V$) $I_{OUT}=100\text{mA}$		10	30	1100	
Shutdown Current ($EN=0$)	I_{SHUT}	$V_{IN}=60V, V_{EN}=0$		0.1	1		
Input Voltage	V_{IN}	---	2.2		60	V	
Maximum Output Current	I_{OUTMAX}		150			mA	
Current Limit* ³	I_{LIM}	$V_{EN}=V_{IN}=V_{OUT(S)}+2V,$ $V_{OUT}=0.95 \times V_{OUT(S)}$		240			
Short Circuit Current* ⁴	I_{SHORT}	$V_{IN}=V_{EN}=V_{OUT(S)}+2.0V$ $V_{OUT}=0V$		10			
Power Supply Rejection Ratio	PSRR	$f=10\text{Hz}, I_{OUT}=10\text{mA}$		76		dB	
		$f=100\text{Hz}, I_{OUT}=10\text{mA}$		80			
		$f=1\text{kHz}, I_{OUT}=10\text{mA}$		63			
EN 'H' Level Voltage	V_{ENH}		1.5		60	V	
EN 'L' Level Voltage	V_{ENL}		0		0.6		
EN 'H' Level Current	I_{ENH}	$V_{IN}=60V, V_{EN}=V_{IN}$	-0.1		0.1	uA	
EN 'L' Level Current	I_{ENL}	$V_{IN}=60V, V_{EN}=0$	-0.1		0.1		
Over Temperature Protection	OTP	$I_{OUT}=1\text{mA}$		165		$^\circ\text{C}$	

Notes:

- $V_{OUT(S)}$: Output voltage when $V_{IN}=V_{OUT}+2V, I_{OUT}=1\text{mA}$.
- $V_{DROP}=V_{IN1} - (V_{OUT(S)} \times 0.98)$ where V_{IN1} is the input voltage when $V_{OUT} = V_{OUT(S)} \times 0.98$.
- I_{LIM} : Output current when $V_{IN}=V_{OUT(S)}+2V$ and $V_{OUT} = 0.95 \times V_{OUT(S)}$.
- V_{OUT} pin should be shorted to GND pin, and the impedance between them is less than 0.1 ohm.

■ Typical Performance Characteristics

Test Conditions: $V_{IN}=V_{OUT}+2.0V$, $C_{IN}=2.2\mu F$, $C_{OUT}=2.2\mu F$, $T_a=25^\circ C$, unless otherwise indicated.

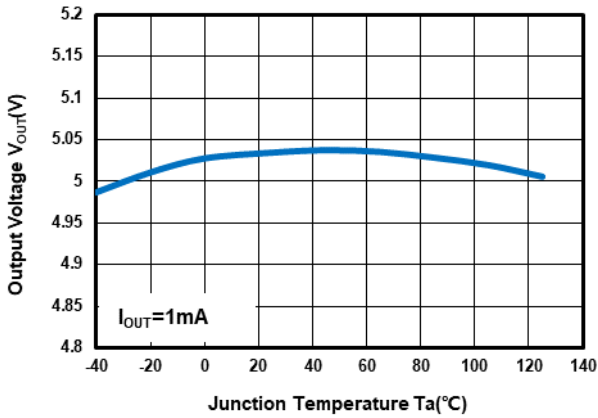

Output Voltage vs Temperature at $V_{OUT}=5.0V$

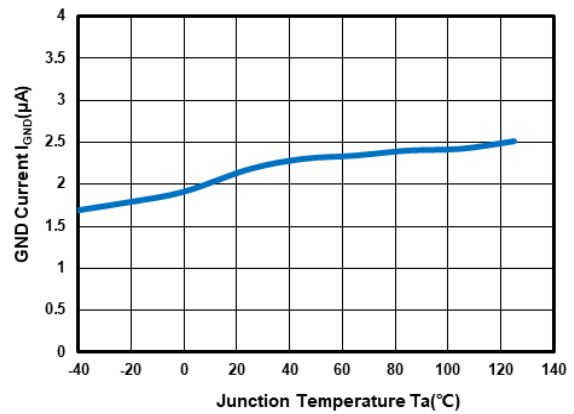

GND Current vs Temperature at $V_{OUT}=5.0V$

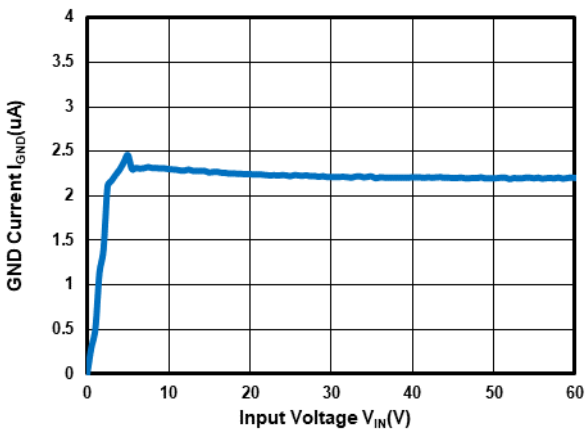

GND Current vs Input Voltage at $V_{OUT}=5.0V$

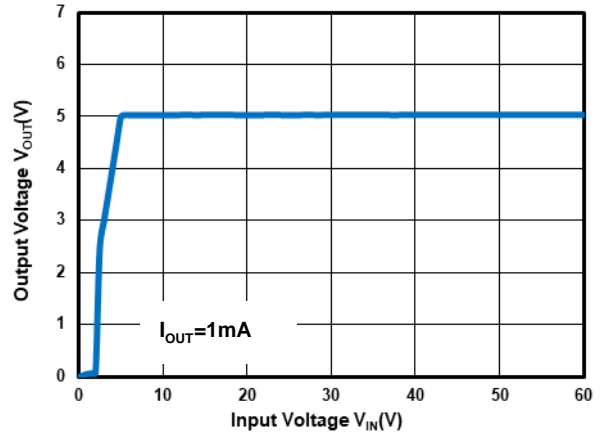

Output Voltage vs Input Voltage at $V_{OUT}=5.0V$

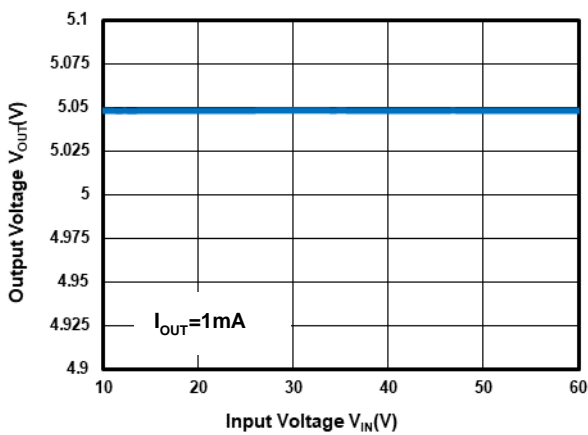

Output Voltage vs Input Voltage at $V_{OUT}=5.0V$

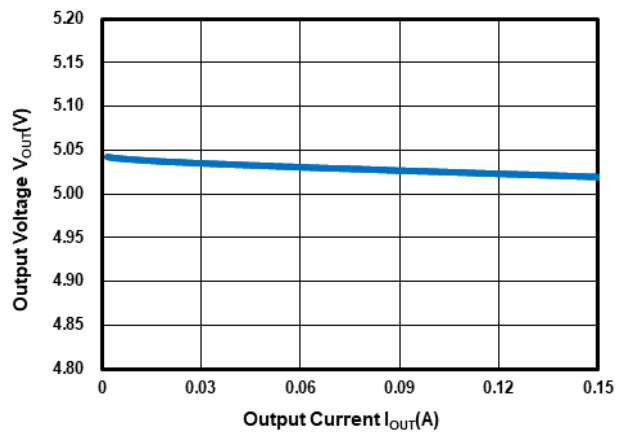

Output Voltage vs Output Current at $V_{OUT}=5.0V$

■ Typical Performance Characteristics (Continued)

Test Conditions: $V_{IN}=V_{OUT}+2.0V$, $C_{IN}=2.2\mu F$, $C_{OUT}=2.2\mu F$, unless otherwise indicated.

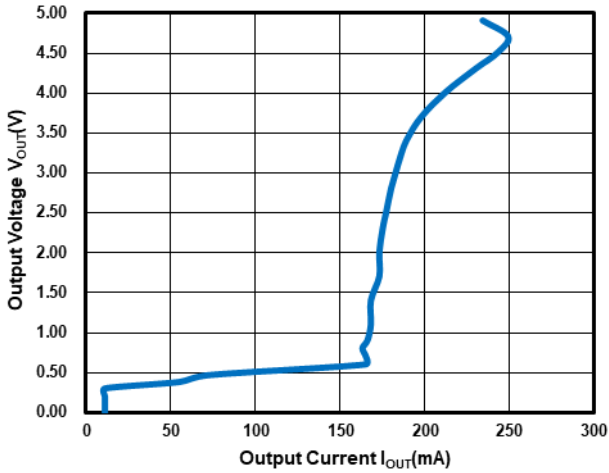

Output Current Fold-back at $V_{OUT}=5.0V$

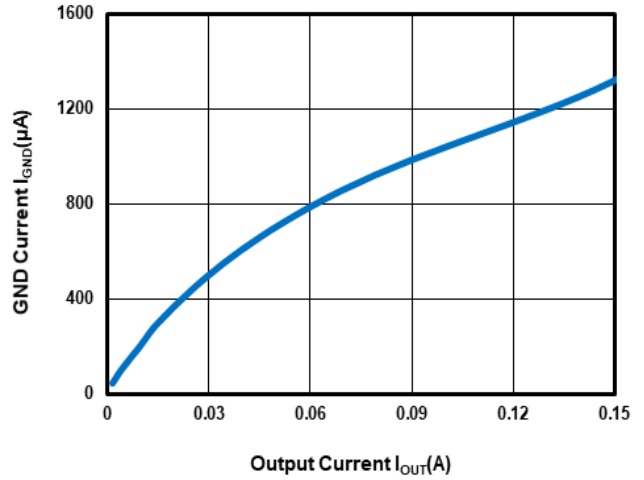

GND Current vs Output Current at $V_{OUT}=5.0V$

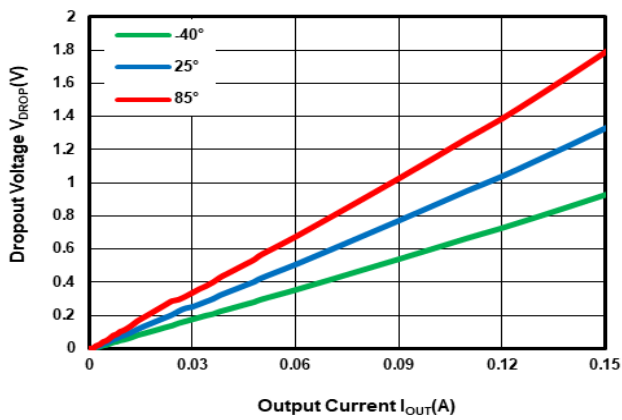

Dropout Voltage vs Temperature at $V_{OUT}=5.0V$

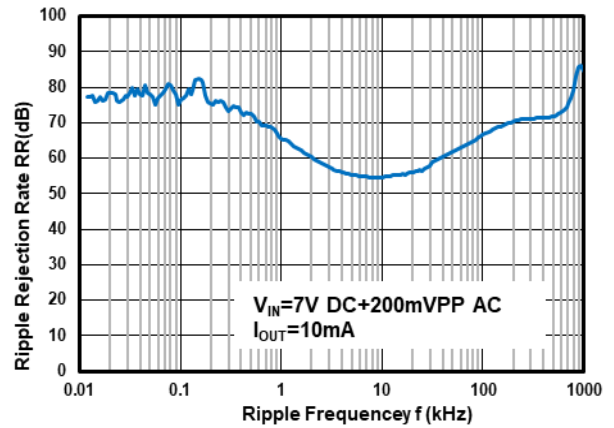

Power Supply Rejection Ratio at $V_{OUT}=5.0V$

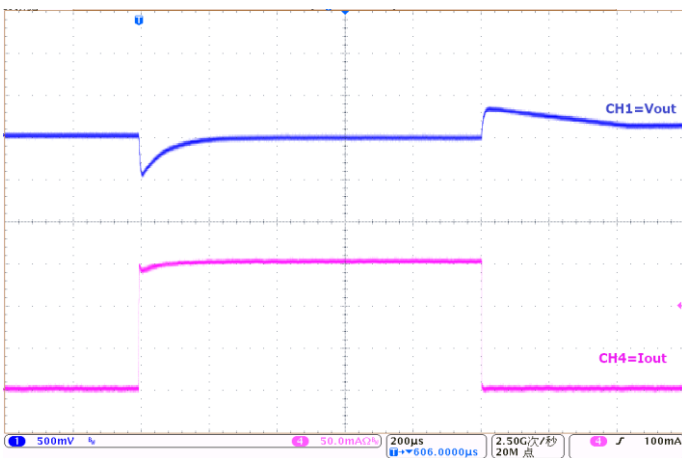

Load Transient at $V_{OUT}=5.0V$:
($I_{OUT}=0mA\sim 150mA\sim 0mA$)

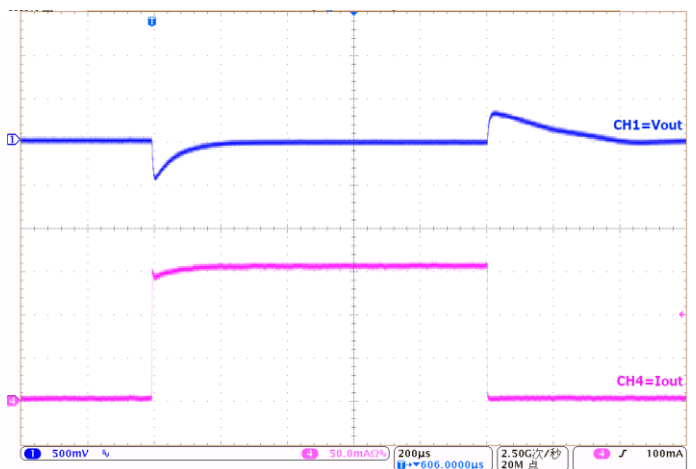

Load Transient at $V_{OUT}=5.0V$:
($I_{OUT}=1mA\sim 150mA\sim 1mA$)

■ Typical Performance Characteristics (Continued)

Test Conditions: $V_{IN}=V_{OUT}+2.0V$, $C_{IN}=2.2\mu F$, $C_{OUT}=2.2\mu F$, $T_a=25^\circ C$, unless otherwise indicated.

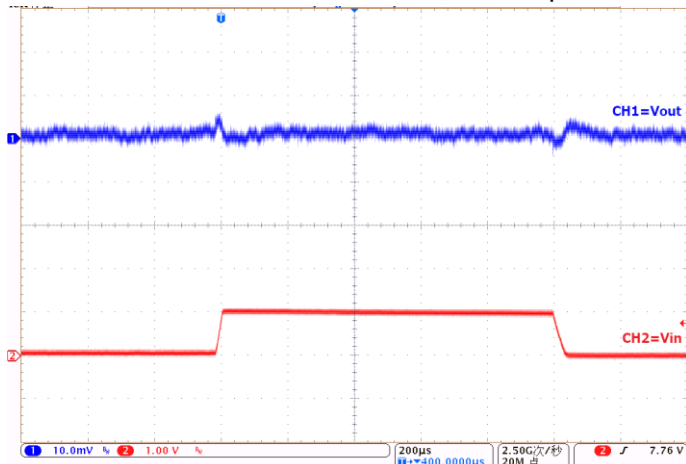

Line Transient at $V_{OUT}=5.0V$:
($I_{OUT}=1mA$):

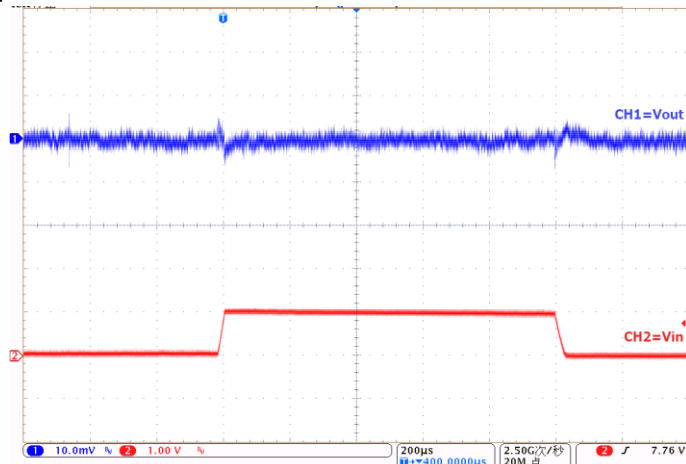

Line Transient at $V_{OUT}=5.0V$:
($I_{OUT}=10mA$):

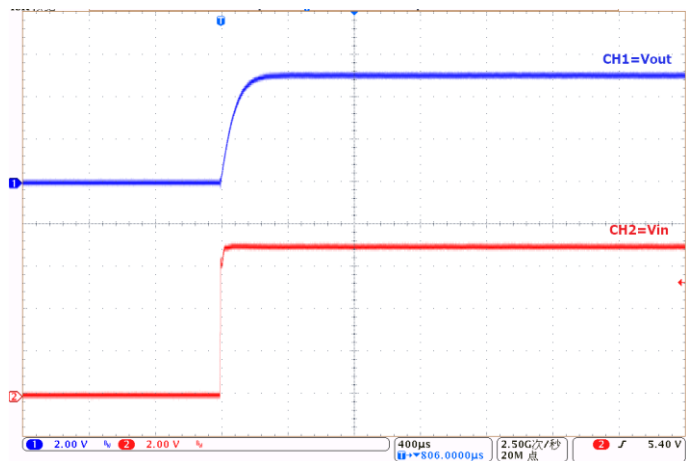

Power-Up at $V_{OUT}=5.0V$:
($I_{OUT}=1mA$)

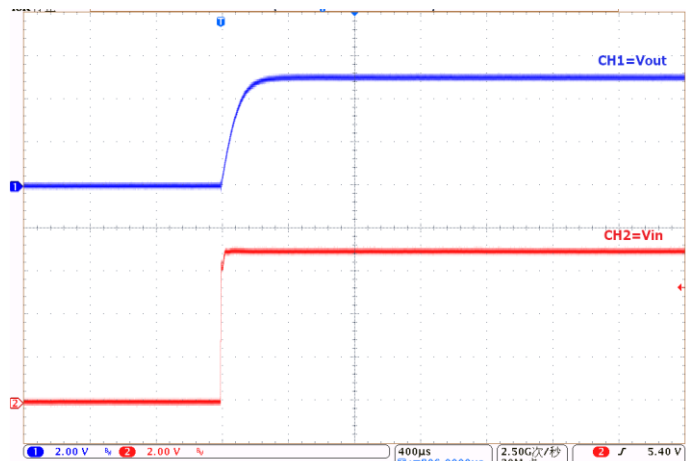

Power-Up at $V_{OUT}=5.0V$:
($I_{OUT}=150mA$)

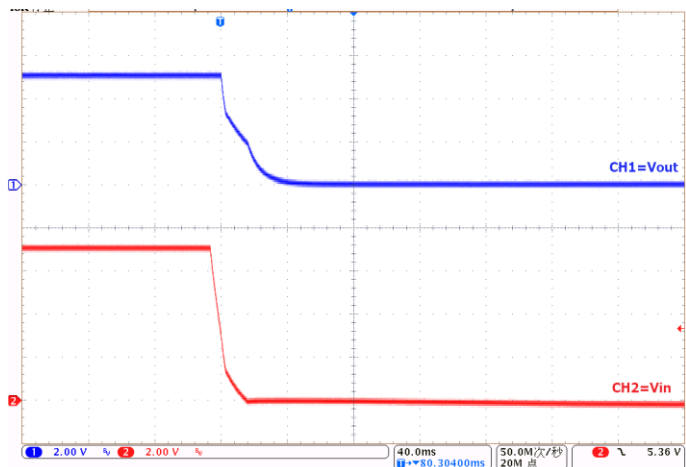

Power-Down at $V_{OUT}=5.0V$:
($I_{OUT}=1mA$)

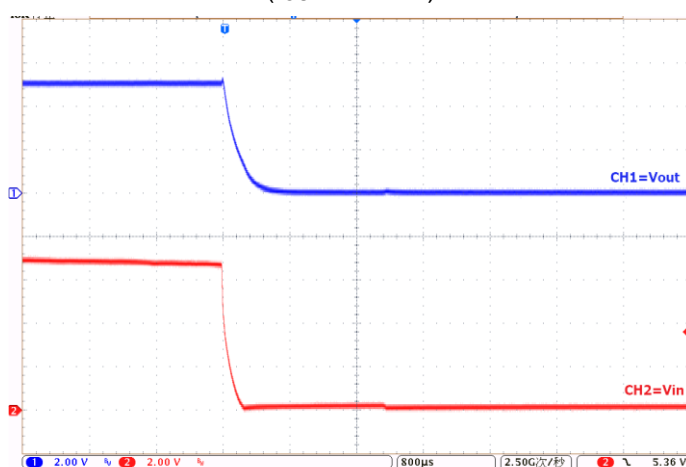

Power-Down at $V_{OUT}=5.0V$:
($I_{OUT}=150mA$)

■ Operational Explanation

1. Output voltage control

The voltage divided by resistors R1 and R2 is compared with the internal reference voltage by the error amplifier. The amplifier output then drives the P-channel MOSFET connected to the V_{OUT} pin. The output voltage at the V_{OUT} pin is regulated by this negative feedback system. The current limit circuit and short protect circuit operate in relation to output current level. Further, the IC's internal circuitry can be in operation or shutdown modes controlled by the CE pin's signal.

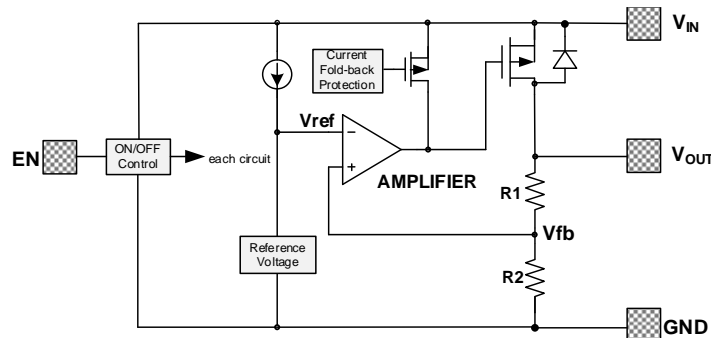

2. Pass transistor

The pass transistor with low turn-on resistance used in MD7680 is a P-channel MOSFET. If the potential on V_{OUT} pin is higher than V_{IN} , it is possible that IC will be destroyed due to reverse current which is caused by parasitic diodes between V_{IN} and V_{OUT} . Therefore, the V_{OUT} pin potential exceeds $V_{IN}+0.3V$ is not allowed.

3. Current foldback and over temperature protection

The MD7680 series includes a combination of a fixed current limiter circuit and a foldback circuit, which aid the operations of the current limiter and circuit protection. When the load current reaches the current limit level, the fixed current limiter circuit operates and output voltage drops. As a result of this drop in output voltage, the foldback circuit operates, output voltage drops further and output current decreases. This design can prevent the chip be damaged due to over temperature, moreover, the heat dissipation is limited by the package type.

Special attention should be paid to that the product of the dropout voltage on the chip and the output current must be smaller than the heat dissipation. If power consumption on the chip is more than the heat dissipation, OTP will protect the chip from damaging due to over temperature.

■ Notes:

1. The input and output capacitors should be placed as close as possible to the IC.
2. If the impedance of the power supply is high, which is caused by forgetting installing input capacitor or installing too small value capacitor, the oscillation may occur.
3. Pay attention to the operation conditions of input and output voltage and load current, such that the power consumption in the IC should not exceed the allowable power consumption of the package even though the chip has short circuit protection.
4. IC has a built-in anti-static protection (ESD) circuit, but please do not add excessive stress to the IC.

■ Packaging Information

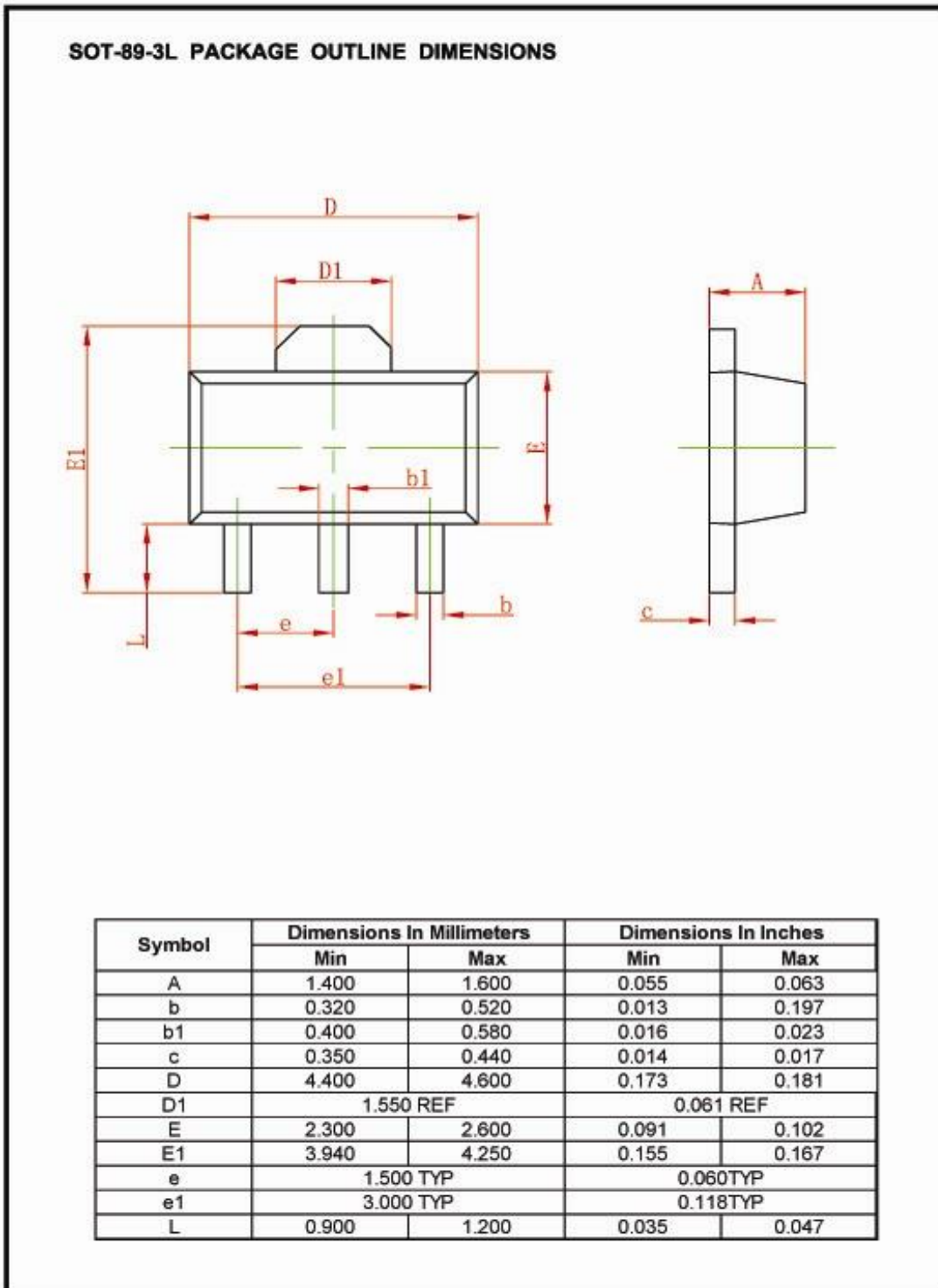

■ Packaging Information (Continued)

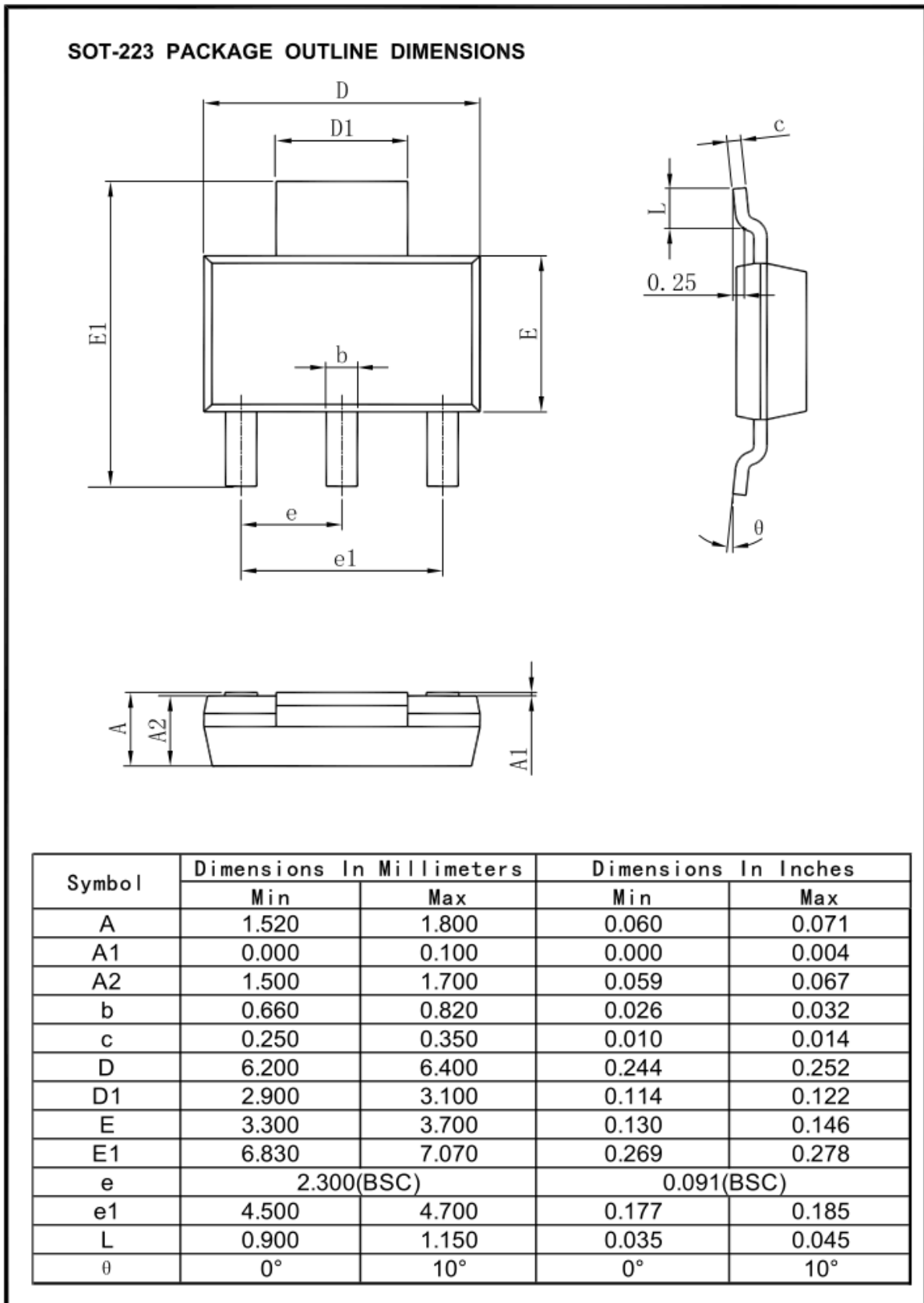

■ Packaging Information (Continued)

SOT-89-5L PACKAGE OUTLINE DIMENSIONS

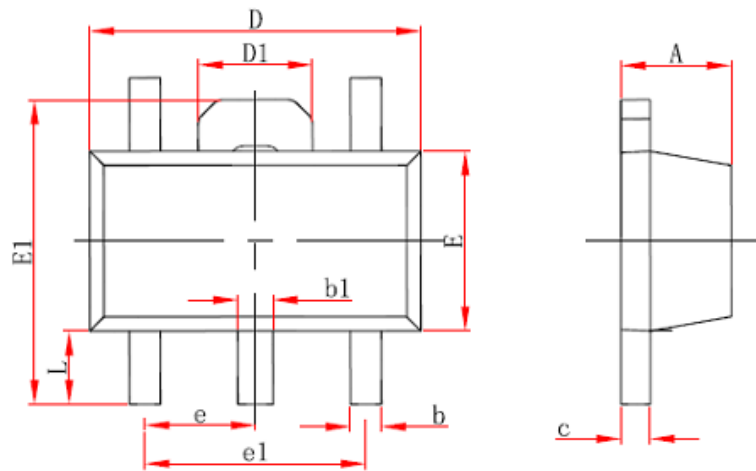

Symbol	Dimensions In Millimeters		Dimensions In Inches	
	Min.	Max.	Min.	Max.
A	1.400	1.600	0.055	0.063
b	0.320	0.520	0.013	0.020
b1	0.380	0.580	0.015	0.023
c	0.350	0.440	0.014	0.017
D	4.400	4.600	0.173	0.181
D1	1.550 REF.		0.061 REF.	
E	2.300	2.600	0.091	0.102
E1	3.940	4.250	0.155	0.167
e	1.500 TYP.		0.060 TYP.	
e1	3.000 TYP.		0.118 TYP.	
L	0.900	1.200	0.035	0.047

■ Packaging Information (Continued)

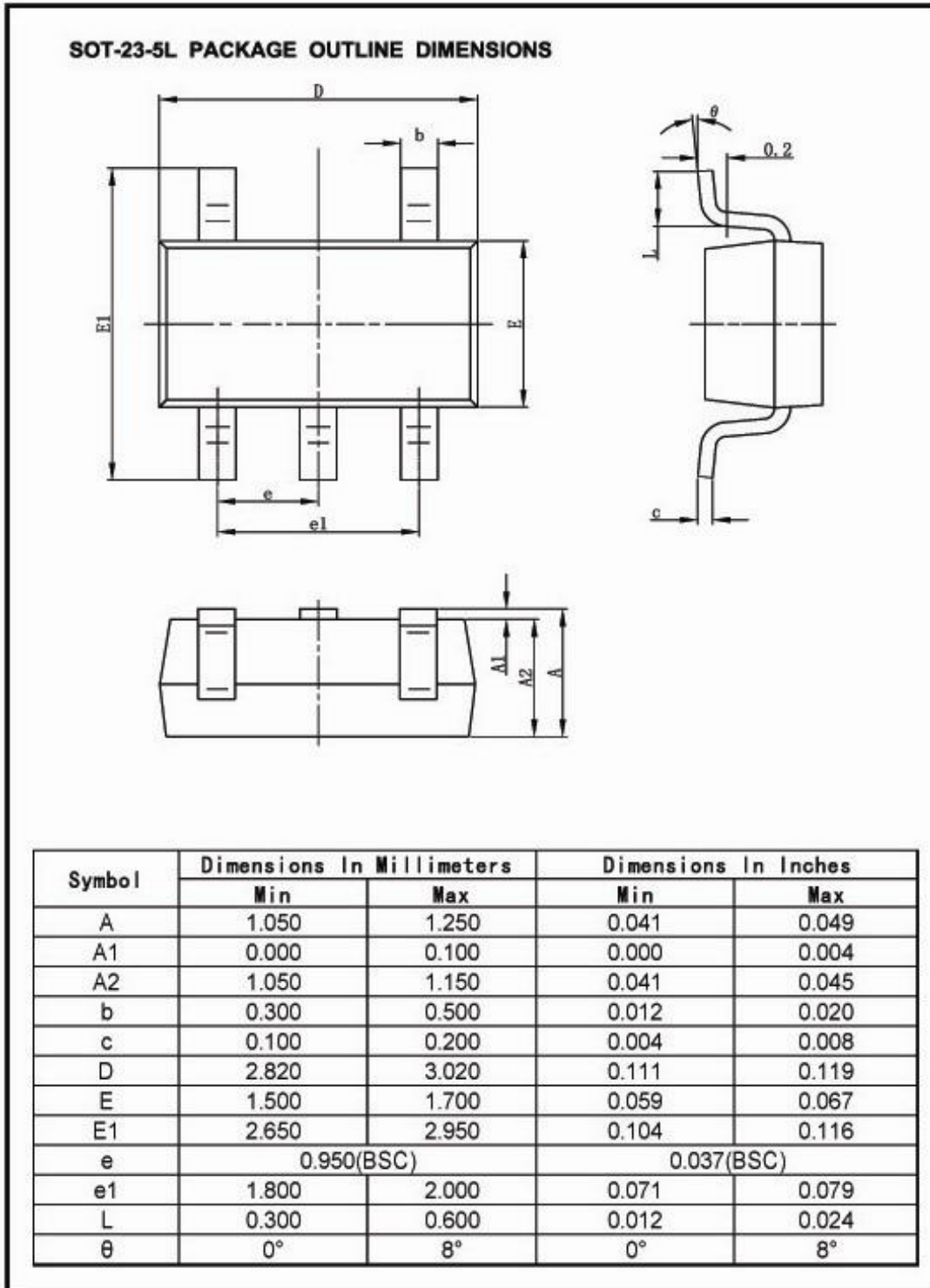

■ Packaging Information (Continued)

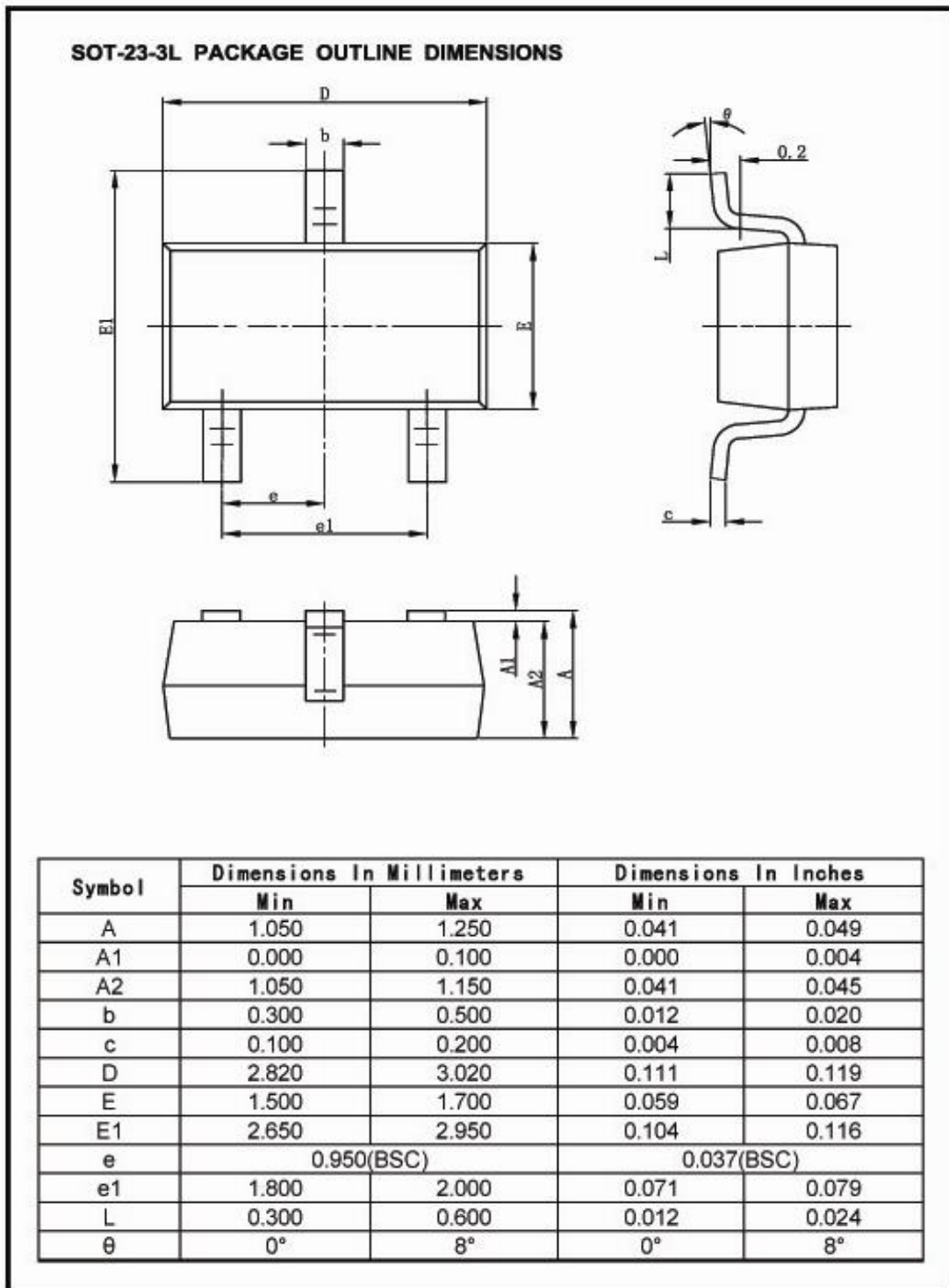

■ Packaging Information (Continued)

T0252-2L PACKGE OUTLINE DIMENSIONS

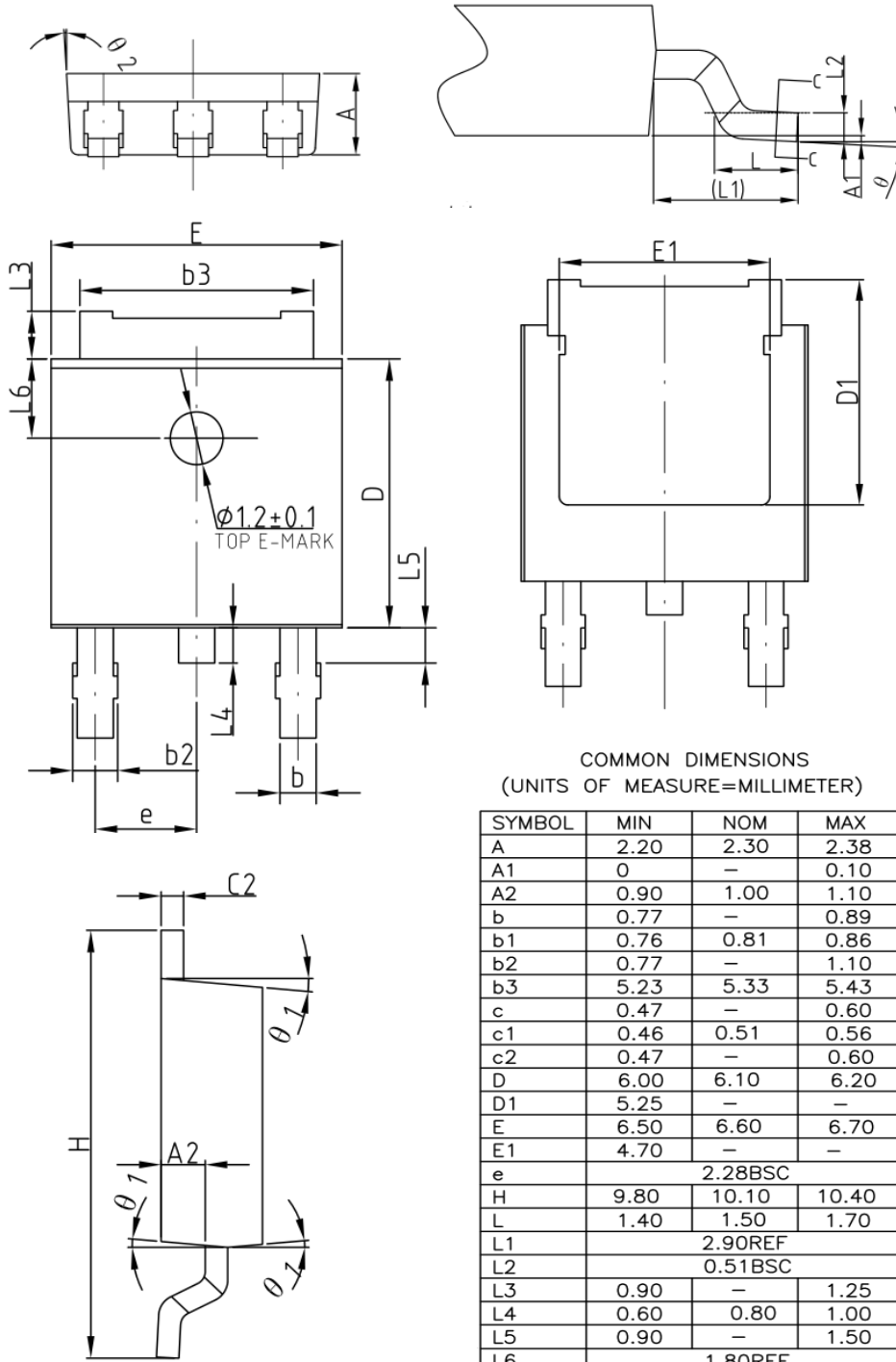

COMMON DIMENSIONS
(UNITS OF MEASURE=MILLIMETER)

SYMBOL	MIN	NOM	MAX
A	2.20	2.30	2.38
A1	0	-	0.10
A2	0.90	1.00	1.10
b	0.77	-	0.89
b1	0.76	0.81	0.86
b2	0.77	-	1.10
b3	5.23	5.33	5.43
c	0.47	-	0.60
c1	0.46	0.51	0.56
c2	0.47	-	0.60
D	6.00	6.10	6.20
D1	5.25	-	-
E	6.50	6.60	6.70
E1	4.70	-	-
e	2.28BSC		
H	9.80	10.10	10.40
L	1.40	1.50	1.70
L1	2.90REF		
L2	0.51BSC		
L3	0.90	-	1.25
L4	0.60	0.80	1.00
L5	0.90	-	1.50
L6	1.80REF		
theta	0°	-	8°
theta 1	3°	5°	7°
theta 2	1°	3°	5°

■ Packaging Information (Continued)

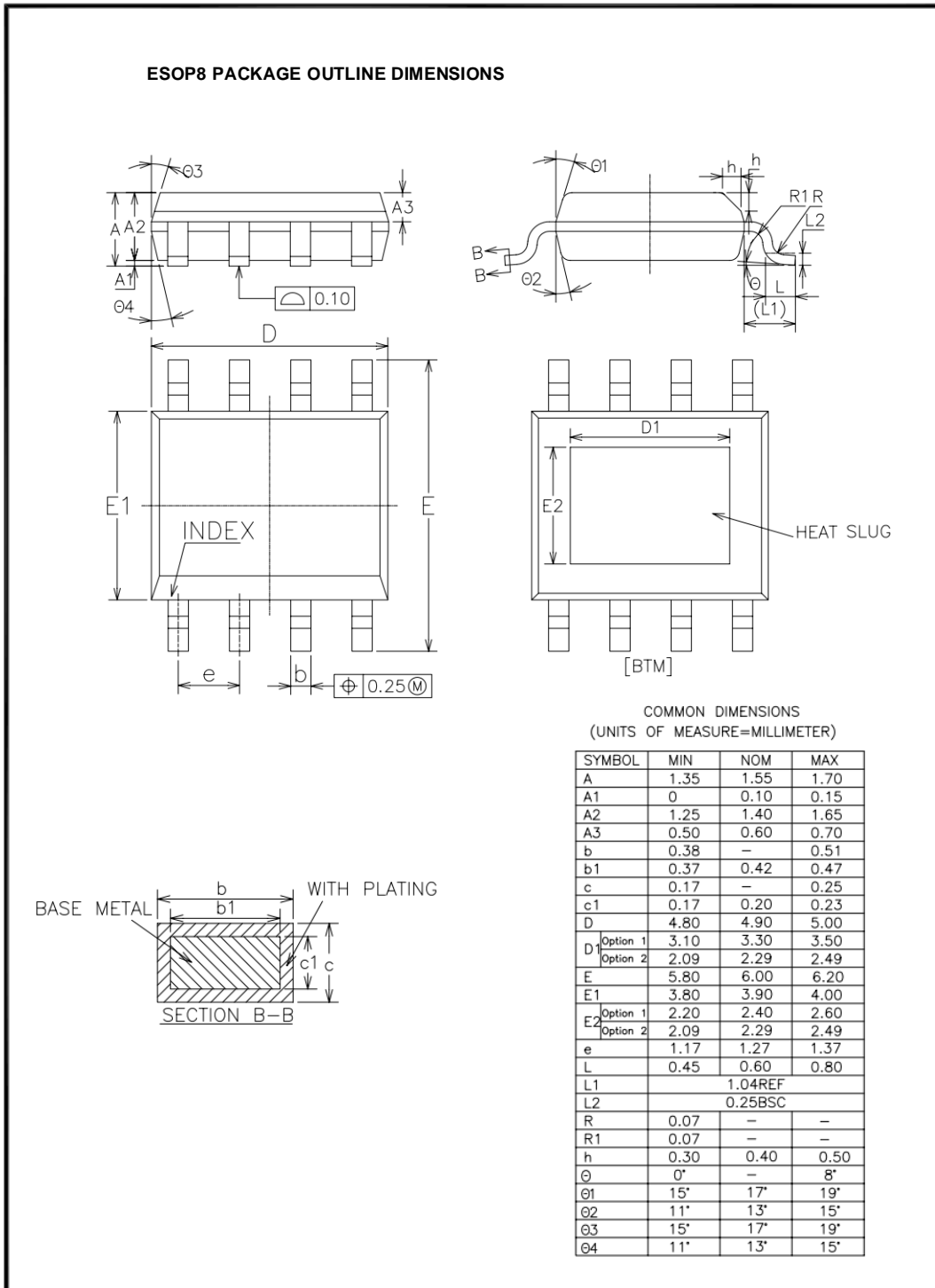

For the newest datasheet, please see the website:

www.md-ic.com.cn

Version V1.0 20231128

X-ON Electronics

Largest Supplier of Electrical and Electronic Components

Click to view similar products for [LDO Voltage Regulators](#) category:

Click to view products by [Mingda](#) manufacturer:

Other Similar products are found below :

[AP7363-SP-13](#) [NCV8664CST33T3G](#) [L79M05TL-E](#) [L9454](#) [AP7362-HA-7](#) [PT7M8202B12TA5EX](#) [TCR3DF185,LM\(CT](#) [TLF4949EJ](#) [L9708](#)
[L970813TR](#) [NCP4687DH15T1G](#) [NCV8703MX30TCG](#) [NCV4269CPD50R2G](#) [AP7315-25W5-7](#) [AP2111H-1.2TRG1](#) [ZLDO1117QK50TC](#)
[NCP114BMX075TCG](#) [MC33269T-3.5G](#) [TLE4471GXT](#) [NCV4266-2CST33T3G](#) [NCP715SQ15T2G](#) [NCV8623MN-50R2G](#)
[NCV563SQ18T1G](#) [NCV8664CDT33RKG](#) [NCV4299CD250R2G](#) [NCP715MX30TBG](#) [NCV8702MX25TCG](#) [L974113TR](#) [TLE7270-2E](#)
[NCV562SQ25T1G](#) [NCP715MX53TBG](#) [AP2202K-2.6TRE1](#) [NCV8170BMX300TCG](#) [NCV8152MX300180TCG](#) [NCP700CMT45TBG](#)
[AP7315-33W5-7](#) [LD56100DPU28R](#) [NCP154MX180300TAG](#) [NJM2878F3-45-TE1](#) [S-1313D18-N4T1U4](#) [AP7343D-31FS4-7B](#) [AP7315D-](#)
[33FS4-7B](#) [LD59150PUR](#) [XC6215B3027R-G](#) [XC6216C201MR-G](#) [XC6504A2019R-G](#) [XC6504A2517R-G](#) [XC6504A251NR-G](#)
[XC6702D331ER-G](#) [NCP3334AMTADJTBG](#)