



LUXEON CoB Core Range Gen 6

Uniform, high efficacy and easy to design array

LUXEON CoB represents a new breakthrough for arrays. Due to its small Light Emitting Surface (LES) and industry-leading thermal resistance, LUXEON CoB is easy to work with, enabling simplified and less expensive luminaire designs. LUXEON CoBs are hot-tested at 85°C—real world operating conditions—which means additional testing can be minimized. LUXEON CoB LEDs are available in 3-step MacAdam ellipse, ensuring uniform optical performance in a wide range of applications.



FEATURES AND BENEFITS

Highest flux densities with industry's smallest LES

3-step MacAdam ellipse color definition: *Freedom from Binning* for color consistency from luminaire to luminaire

Up to 4x lower thermal resistance than competition, enabling smaller heatsinks and higher lumens

Supported by a comprehensive optical, mechanical and electrical ecosystem

PRIMARY APPLICATIONS

Spotlights

Track Lights

Downlights

High Bay

Low Bay

Floodlights

[More...](#)

Table of Contents

General Product Information	2
Product Test Conditions	2
Part Number Nomenclature	2
Environmental Compliance	2
Performance Characteristics	3
Product Selection Guide	3
Optical Characteristics	4
Electrical and Thermal Characteristics	4
Absolute Maximum Ratings	5
Characteristic Curves	5
Spectral Power Distribution Characteristics	5
Light Output Characteristics	6
Forward Current Characteristics	10
Radiation Pattern Characteristics	14
Color Bin Definitions	15
Mechanical Dimensions	16
Packaging and Labeling Information	17
Tube	17
Inner Box	19
Outer Box	20

General Product Information

Product Test Conditions

LUXEON CoB Core Range LEDs are tested and binned with a DC drive current specified below at a junction temperature, T_j , of 85°C:

200mA	-	L2C5-AABB1202I060G
200mA	-	L2C5-AABB1202I090G
300mA	-	L2C5-AABB1203I090G
400mA	-	L2C5-AABB1204I090G
600mA	-	L2C5-AABB1205I130G
900mA	-	L2C5-AABB1208I150G
900mA	-	L2C5-AABB1210I150G

Part Number Nomenclature

Part numbers for LUXEON CoB Core Range follow the convention below:

L 2 C 5 - **A A B B C C C C D E E F G**

Where:

- A A** - designates nominal CCT (27=2700K, 30=3000K, 35=3500K, 40=4000K, 50=5000K)
- B B** - designates minimum CRI (90=90CRI)
- C C C C** - designates product configuration (examples: 1202, 1203, 1204, 1205, 1208, 1210)
- D** - designates options for product specification
- E E** - designates light emitting surface (LES) size (06=6mm, 09=9mm, 13=13mm, 15=15mm)
- F** - designates options for product specification
- G** - designates SDCM (2=2-step MacAdam, 0=3-step MacAdam)

Therefore, the following part number is used for a LUXEON Core Range CoB 1208, Gen 6, 3000K 90CRI, 2 SDCM, with a 15mm LES:

L 2 C 5 - **3 0 9 0 1 2 0 8 1 1 5 0 2**

Environmental Compliance

Lumileds LLC is committed to providing environmentally friendly products to the solid-state lighting market. LUXEON CoB Core Range is compliant to the European Union directives on the restriction of hazardous substances in electronic equipment, namely the ROHS Directive 2011/65/EU including amendments 2015/863/EU & 2017/2102/EU and REACH Regulation (EC) 1907/2006. Lumileds LLC will not intentionally add the following restricted materials to its products: lead, mercury, cadmium, hexavalent chromium, polybrominated biphenyls (PBB) or polybrominated diphenyl ethers (PBDE).

Performance Characteristics

Product Selection Guide

Table 1. Product performance of LUXEON CoB Core Range at specified test current, $T_j=85^\circ\text{C}$.

LES ^[1] (mm)	NOMINAL CCT	MINIMUM CRI ^[2, 3, 4]	LUMINOUS FLUX ^[2] (lm)		TYPICAL LUMINOUS EFFICACY (lm/W)	TEST CURRENT (mA)	ENERGY EFFICIENCY CLASS ^[5]	PART NUMBER ^[6]
			MINIMUM	TYPICAL				
6	2700K	90	984	1093	161	200	D	L2C5-27901202I060x
6	3000K	90	978	1087	160	200	D	L2C5-30901202I060x
6	3500K	90	994	1105	163	200	D	L2C5-35901202I060x
6	4000K	90	1007	1119	165	200	D	L2C5-40901202I060x
6	5000K	90	1012	1124	166	200	D	L2C5-50901202I060x
9	2700K	90	1013	1126	166	200	D	L2C5-27901202I090x
9	3000K	90	1008	1120	165	200	D	L2C5-30901202I090x
9	3500K	90	1024	1138	168	200	D	L2C5-35901202I090x
9	4000K	90	1037	1152	170	200	D	L2C5-40901202I090x
9	5000K	90	1042	1158	171	200	D	L2C5-50901202I090x
9	2700K	90	1466	1628	160	300	D	L2C5-27901203I090x
9	3000K	90	1458	1620	159	300	D	L2C5-30901203I090x
9	3500K	90	1481	1646	162	300	D	L2C5-35901203I090x
9	4000K	90	1500	1667	164	300	D	L2C5-40901203I090x
9	5000K	90	1508	1675	165	300	D	L2C5-50901203I090x
9	2700K	90	1948	2164	160	400	D	L2C5-27901204I090x
9	3000K	90	1937	2152	159	400	D	L2C5-30901204I090x
9	3500K	90	1968	2187	161	400	D	L2C5-35901204I090x
9	4000K	90	1993	2215	163	400	D	L2C5-40901204I090x
9	5000K	90	2004	2226	164	400	D	L2C5-50901204I090x
13	2700K	90	2857	3174	153	600	D	L2C5-27901205I130x
13	3000K	90	2921	3245	157	600	D	L2C5-30901205I130x
13	3500K	90	3009	3343	162	600	D	L2C5-35901205I130x
13	4000K	90	3083	3426	165	600	D	L2C5-40901205I130x
13	5000K	90	3025	3362	162	600	D	L2C5-50901205I130x
15	2700K	90	4289	4766	155	900	D	L2C5-27901208I150x
15	3000K	90	4485	4983	162	900	D	L2C5-30901208I150x
15	3500K	90	4526	5029	163	900	D	L2C5-35901208I150x
15	4000K	90	4625	5139	167	900	D	L2C5-40901208I150x
15	5000K	90	4552	5057	164	900	D	L2C5-50901208I150x
15	2700K	90	4395	4883	161	900	D	L2C5-27901210I150x
15	3000K	90	4459	4954	164	900	D	L2C5-30901210I150x
15	3500K	90	4538	5042	167	900	D	L2C5-35901210I150x
15	4000K	90	4672	5191	172	900	D	L2C5-40901210I150x
15	5000K	90	4650	5167	171	900	D	L2C5-50901210I150x

Notes for Table 1:

1. Light Emitting Surface (LES) is the inner diameter (phosphor area) inside the dam.
2. Lumileds maintains a tolerance of ± 2 on CRI and $\pm 6.5\%$ on luminous flux measurements.
3. Typical CRI is approximately 2 points higher than the minimum CRI specified, but this is not guaranteed.
4. R9 value of 90CRI products is >50 .
5. Energy efficiency class as specified in Commission Delegated Regulation (EU) 2019/2015. The available range of energy efficiency classes is A-G.
6. Part number ends with "x" designates SDCM available in both 2-step (x=2) and 3-step (x=0) MacAdam.

Optical Characteristics

Table 2. Optical characteristics for LUXEON CoB Core Range at specified test current, $T_j=85^\circ\text{C}$.

PART NUMBER	TYPICAL TOTAL INCLUDED ANGLE ^[1]	TYPICAL VIEWING ANGLE ^[2]
L2C5-xxxxxxxxxx0x	135°	115°

Notes for Table 2:

1. Total angle at which 90% of total luminous flux is captured.
2. Viewing angle is the off axis angle from the LED centerline where the luminous intensity is 1/2 of the peak value.

Electrical and Thermal Characteristics

Table 3. Electrical and thermal characteristics for LUXEON CoB Core Range at specified test current, $T_j=85^\circ\text{C}$.

PART NUMBER	FORWARD VOLTAGE ^[1] (V_f)			TYPICAL TEMPERATURE COEFFICIENT OF FORWARD VOLTAGE ^[2] (mV/°C)	TYPICAL THERMAL RESISTANCE—JUNCTION TO CASE ^[3] (°C/W)
	MINIMUM	TYPICAL	MAXIMUM		
L2C5-xxxx12021060x	31.2	33.9	36.6	-16	0.78
L2C5-xxxx12021090x	31.2	33.9	36.6	-16	0.78
L2C5-xxxx12031090x	31.2	33.9	36.6	-16	0.60
L2C5-xxxx12041090x	31.2	33.9	36.6	-16	0.43
L2C5-xxxx12051130x	31.7	34.5	37.3	-16	0.26
L2C5-xxxx12081150x	31.5	34.2	36.9	-16	0.20
L2C5-xxxx12101150x	30.9	33.6	36.3	-16	0.18

Notes for Table 3:

1. Lumileds maintains a tolerance of $\pm 0.06\text{V}$ on forward voltage measurements.
2. Measured between 25°C and 85°C.
3. Thermal resistance is measured between junction and the bottom of the LUXEON CoB substrate.

Absolute Maximum Ratings

Table 4. Absolute maximum ratings for LUXEON CoB Core Range.

PARAMETER	MAXIMUM PERFORMANCE
DC Forward Current ^[1,2]	2x test current
LED Junction Temperature ^[1] (DC & Pulse)	125°C
ESD Sensitivity (ANSI/ESDA/JEDEC JS-001-2012)	Class 3B
Operating Case Temperature ^[1]	-40°C to 105°C
LED Storage Temperature	-40°C to 120°C
Reverse Voltage ($V_{reverse}$)	LUXEON LEDs are not designed to be driven in reverse bias

Notes for Table 4:

- Proper current derating must be observed to maintain the junction temperature below the maximum allowable junction temperature.
- Residual periodic variations due to power conversion from alternating current (AC) to direct current (DC), also called "ripple," are acceptable if the following conditions are met:
 - The frequency of the ripple current is 100Hz or higher
 - The average current for each cycle does not exceed the maximum allowable DC forward current
 - The maximum amplitude of the ripple does not exceed 20% of the maximum allowable DC forward current

Characteristic Curves

Spectral Power Distribution Characteristics

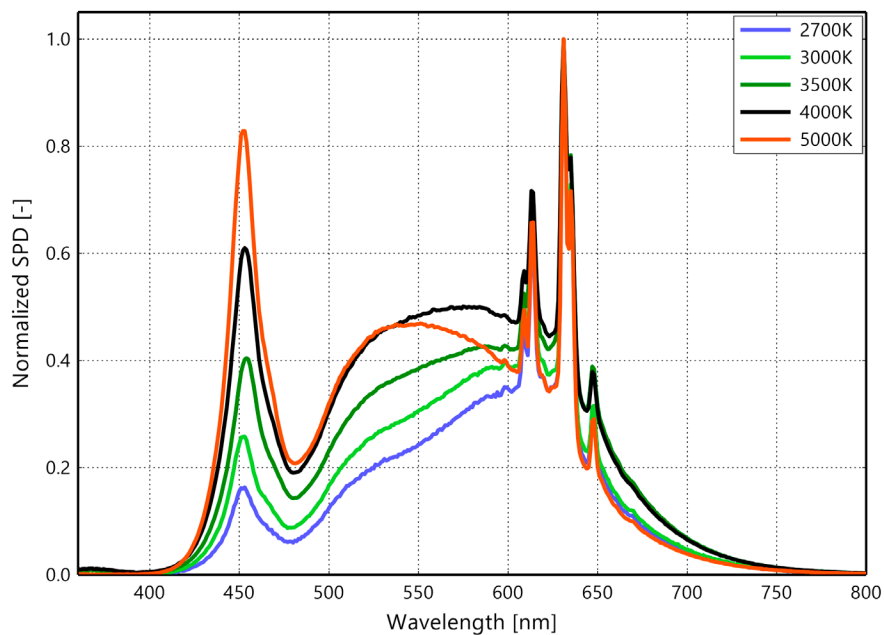

Figure 1. Typical normalized power vs. wavelength for L2C5-xx90xxxxlxx0x at specified test current, $T_j=85^\circ\text{C}$.

Light Output Characteristics

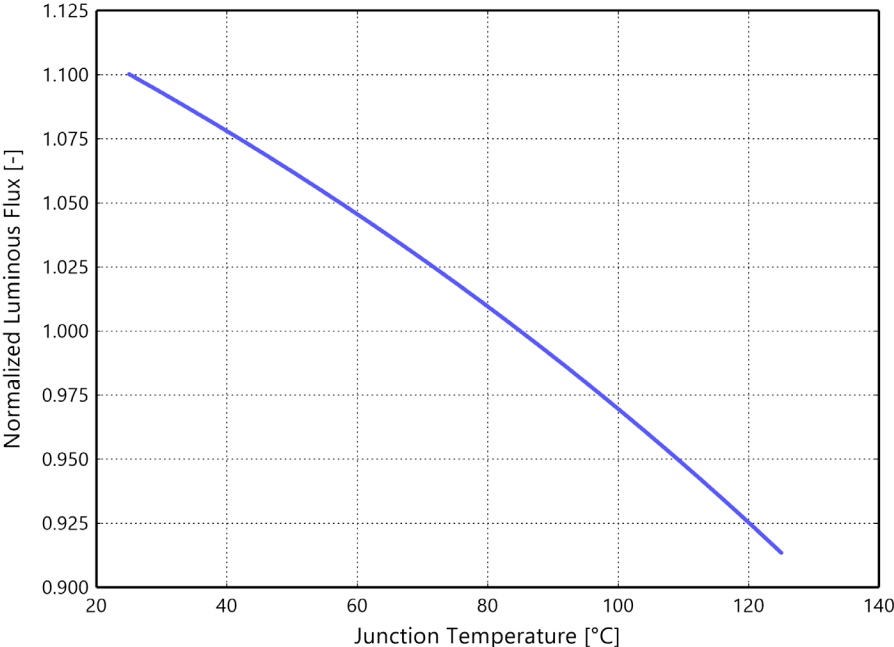

Figure 2. Typical normalized light output vs. junction temperature for L2C5-xxxxxxx1xx0x at specified test current.

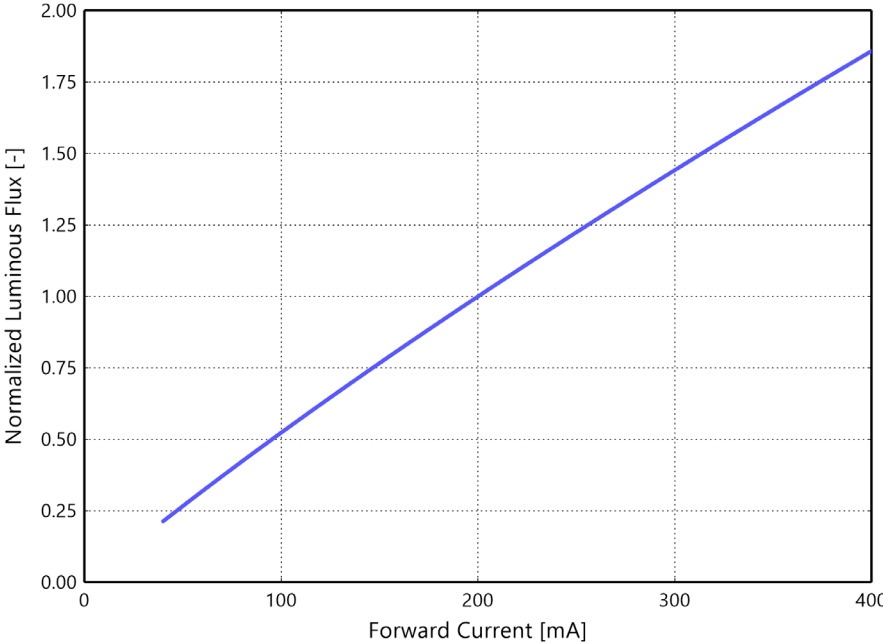

Figure 3a. Typical normalized light output vs. forward current for L2C5-xxxx12021060x at $T_j=85^\circ\text{C}$.

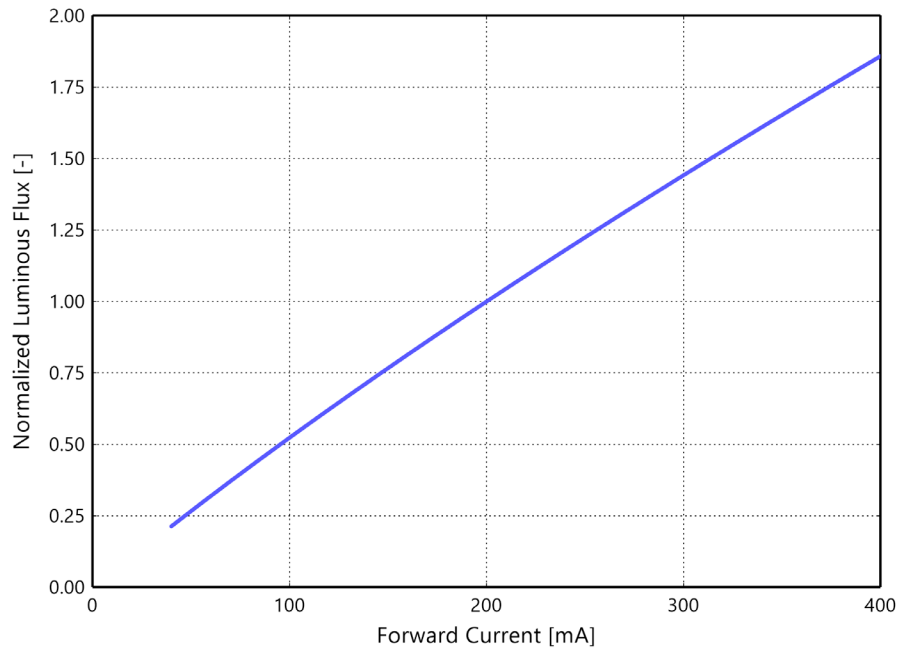

Figure 3b. Typical normalized light output vs. forward current for L2C5-xxxx1202I090x at $T_j=85^\circ\text{C}$.

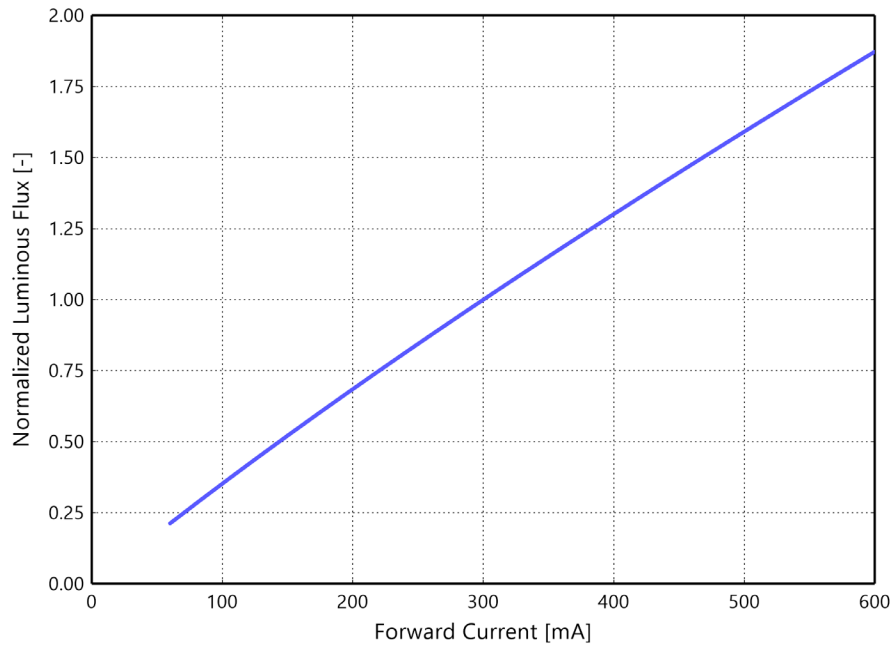

Figure 3c. Typical normalized light output vs. forward current for L2C5-xxxx1203I090x at $T_j=85^\circ\text{C}$.

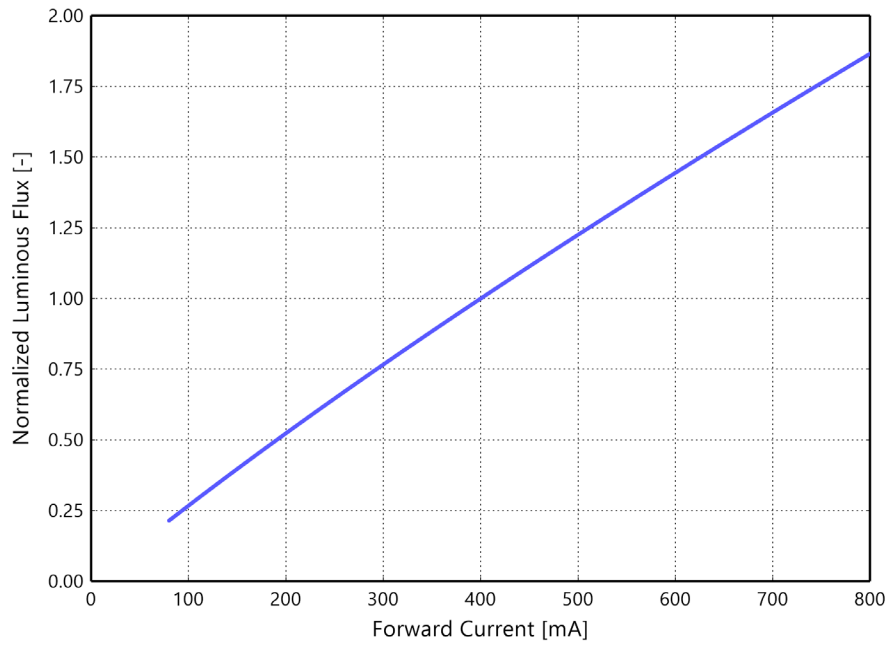

Figure 3d. Typical normalized light output vs. forward current for L2C5-xxxx1204I090x at $T_j=85^\circ\text{C}$.

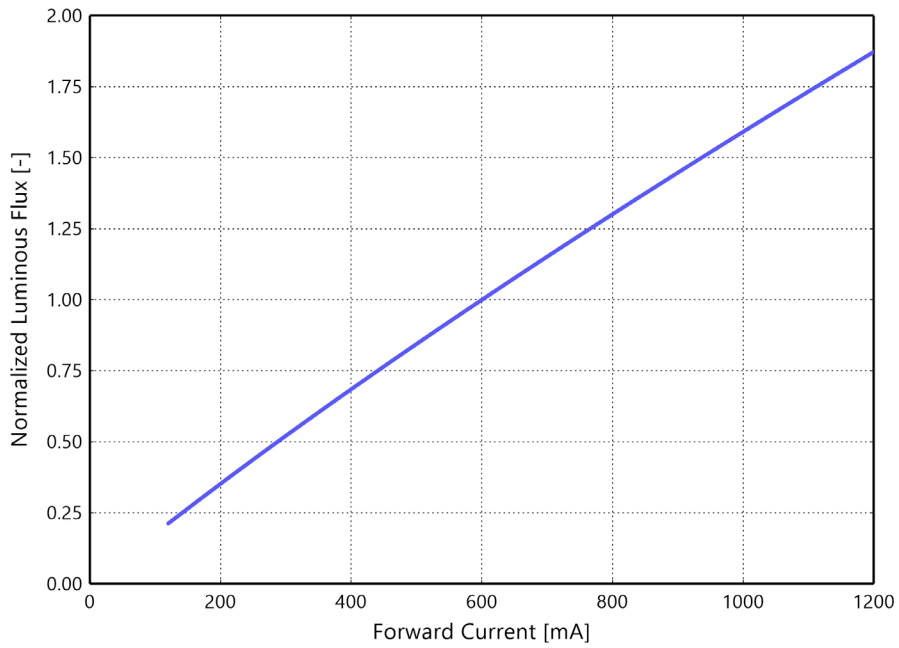

Figure 3e. Typical normalized light output vs. forward current for L2C5-xxxx1205I130x at $T_j=85^\circ\text{C}$.

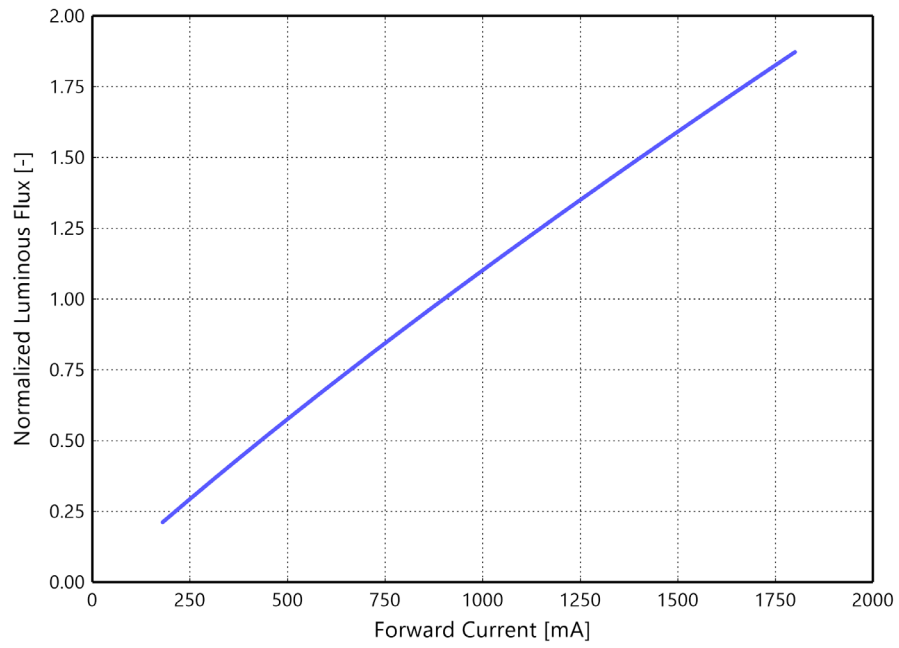

Figure 3f. Typical normalized light output vs. forward current for L2C5-xxxx12081150x at $T_j=85^\circ\text{C}$.

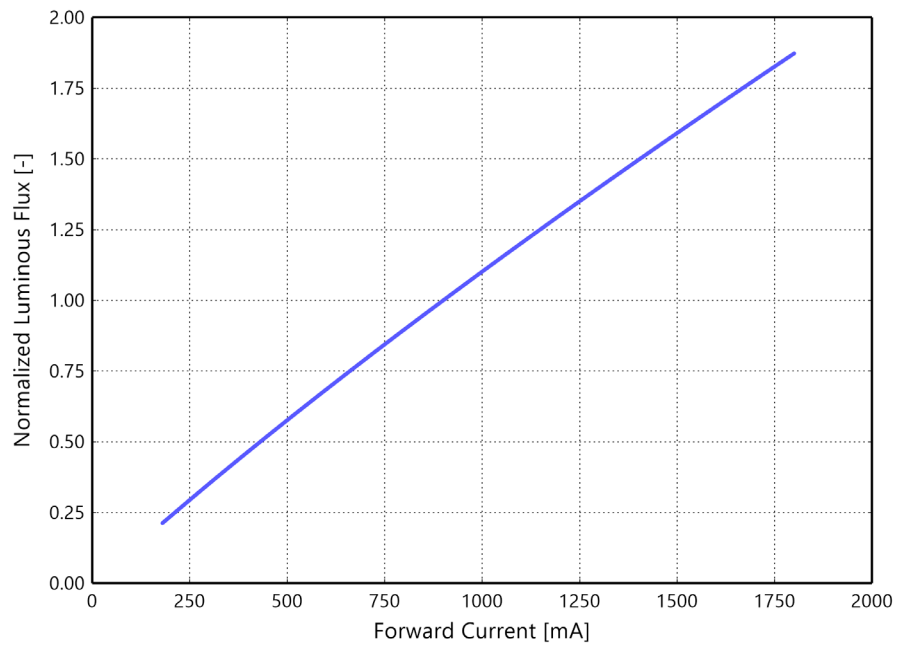

Figure 3g. Typical normalized light output vs. forward current for L2C5-xxxx12101150x at $T_j=85^\circ\text{C}$.

Forward Current Characteristics

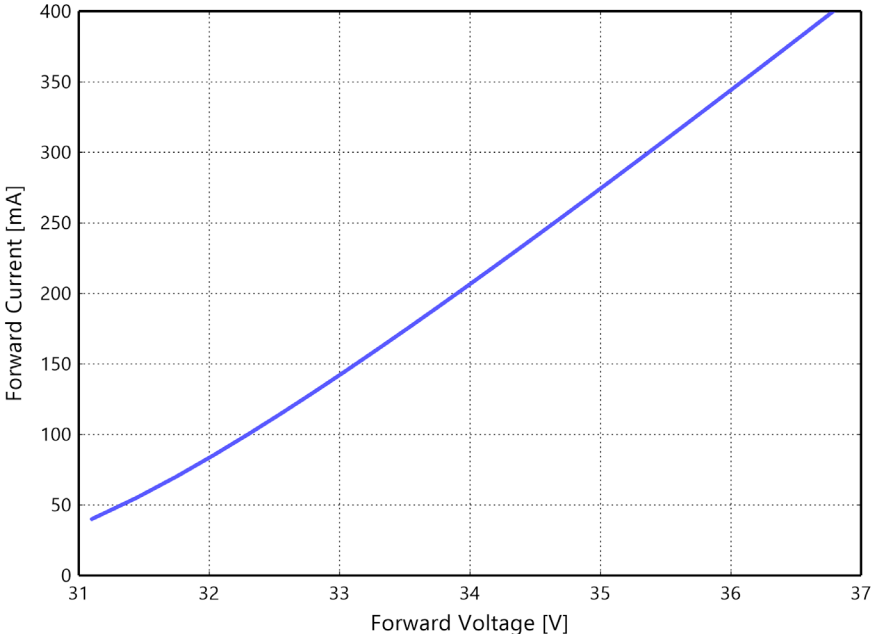

Figure 4a. Typical forward current vs. forward voltage for L2C5-xxxx1202I060x at $T_j=85^\circ\text{C}$.

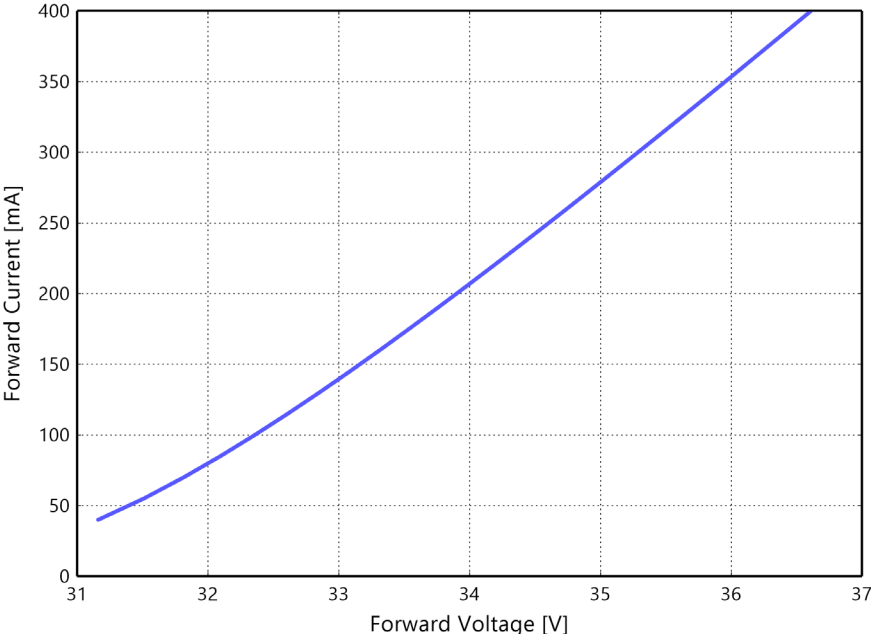

Figure 4b. Typical forward current vs. forward voltage for L2C5-xxxx1202I090x at $T_j=85^\circ\text{C}$.

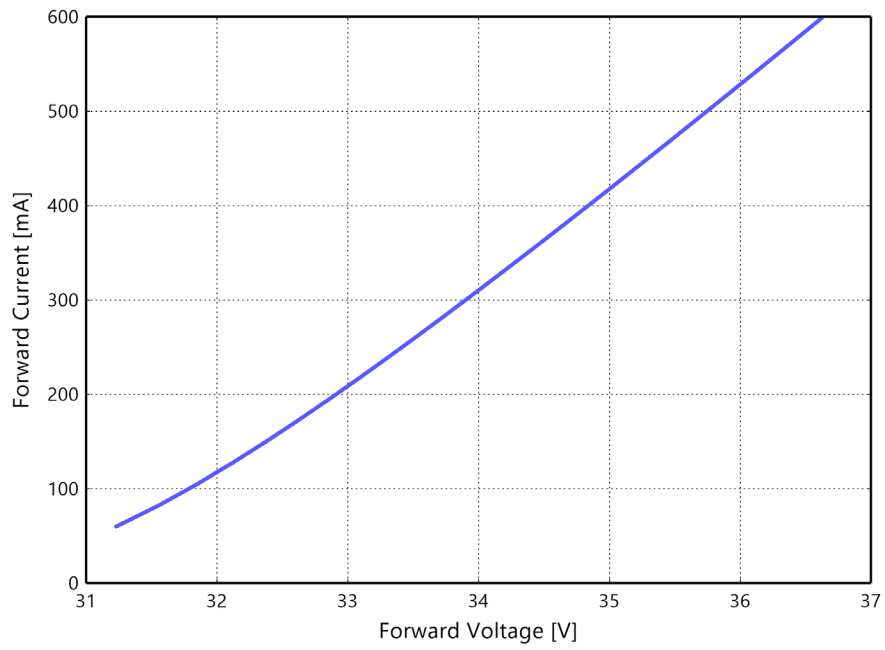

Figure 4c. Typical forward current vs. forward voltage for L2C5-xxxx1203I090x at $T_j=85^\circ\text{C}$.

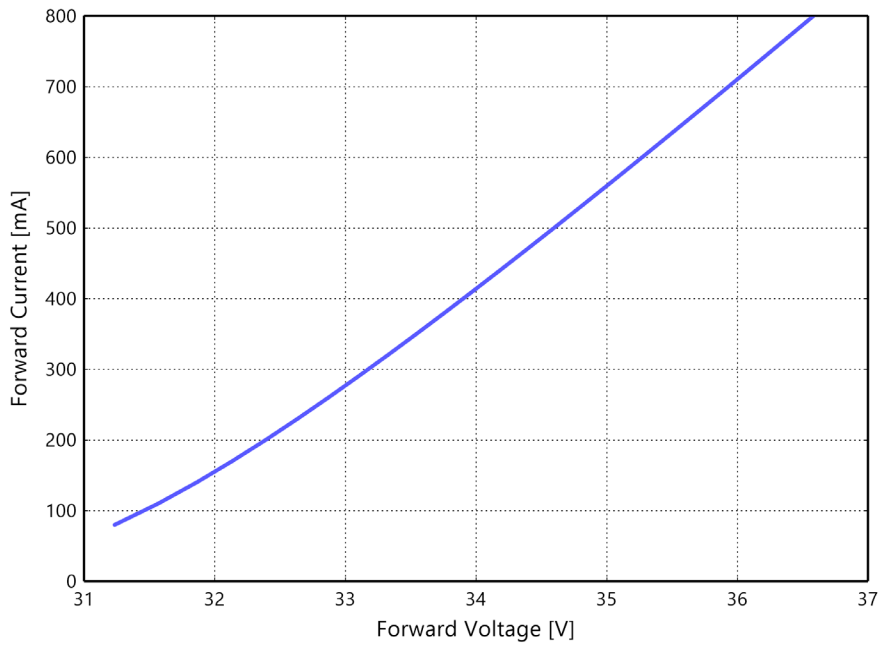

Figure 4d. Typical forward current vs. forward voltage for L2C5-xxxx1204I090x at $T_j=85^\circ\text{C}$.

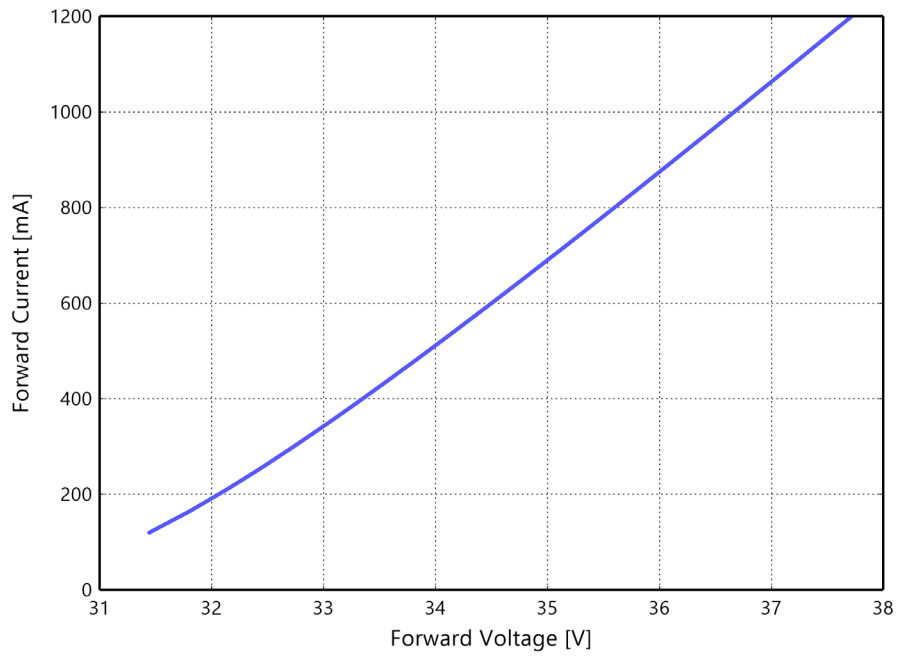

Figure 4e. Typical forward current vs. forward voltage for L2C5-xxxx1205113x0x at $T_j=85^\circ\text{C}$.

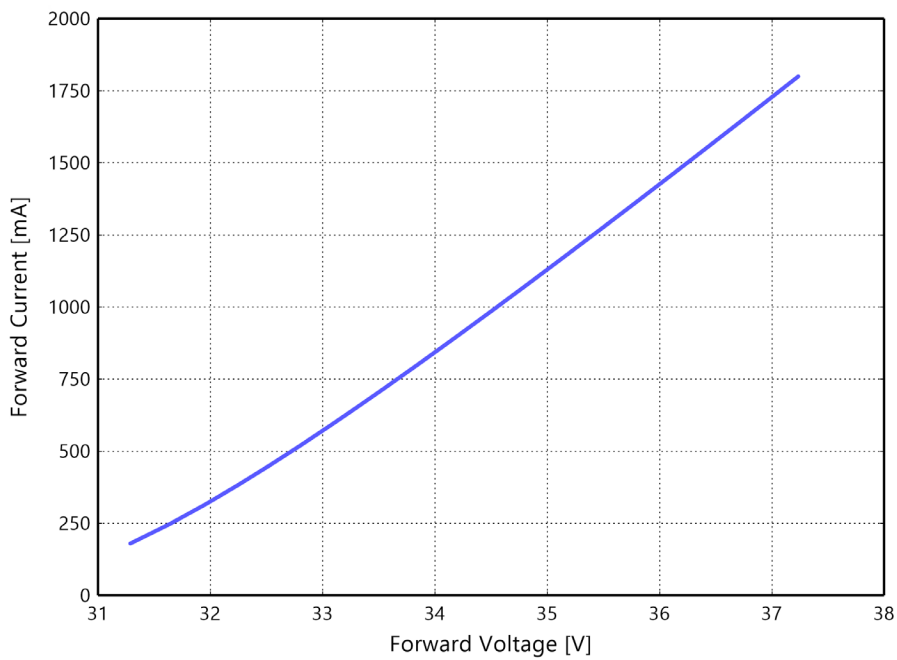

Figure 4f. Typical forward current vs. forward voltage for L2C5-xxxx12081150x at $T_j=85^\circ\text{C}$.

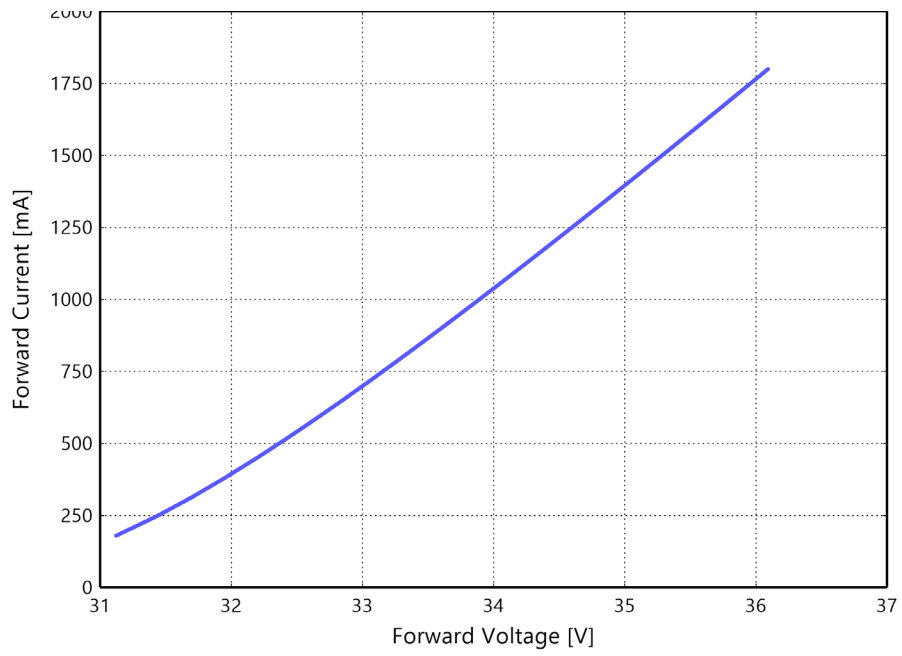

Figure 4g. Typical forward current vs. forward voltage for L2C5-xxxx1210xxx0x at $T_j=85^\circ\text{C}$.

Radiation Pattern Characteristics

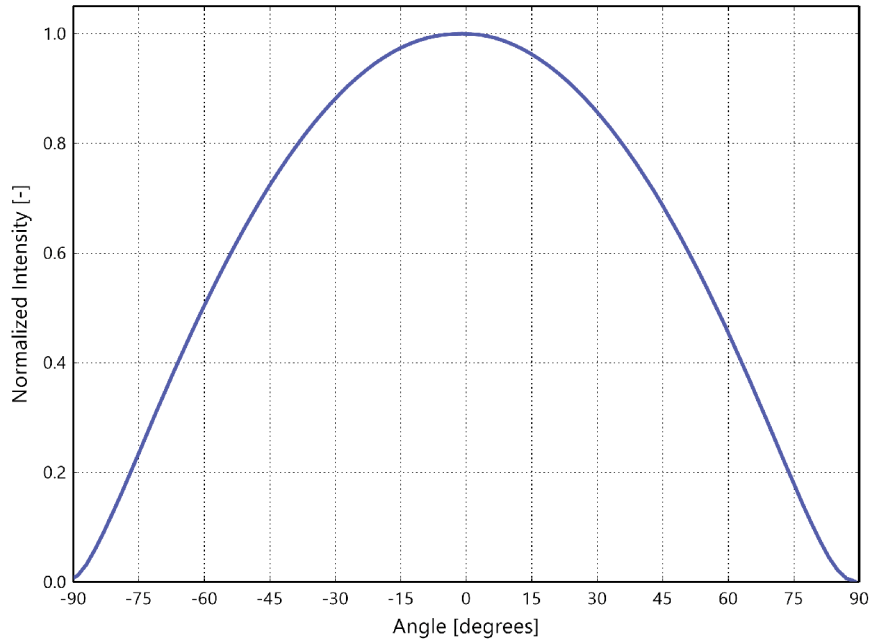

Figure 5. Typical radiation pattern for LUXEON CoB Core Range at specified test current, $T_j=85^{\circ}\text{C}$.

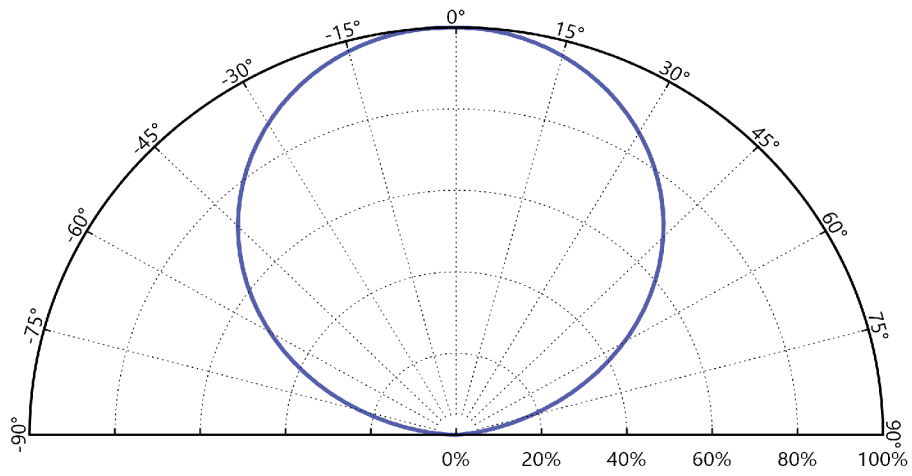

Figure 6. Typical polar radiation pattern for LUXEON CoB Core Range at specified test current, $T_j=85^{\circ}\text{C}$.

Color Bin Definitions

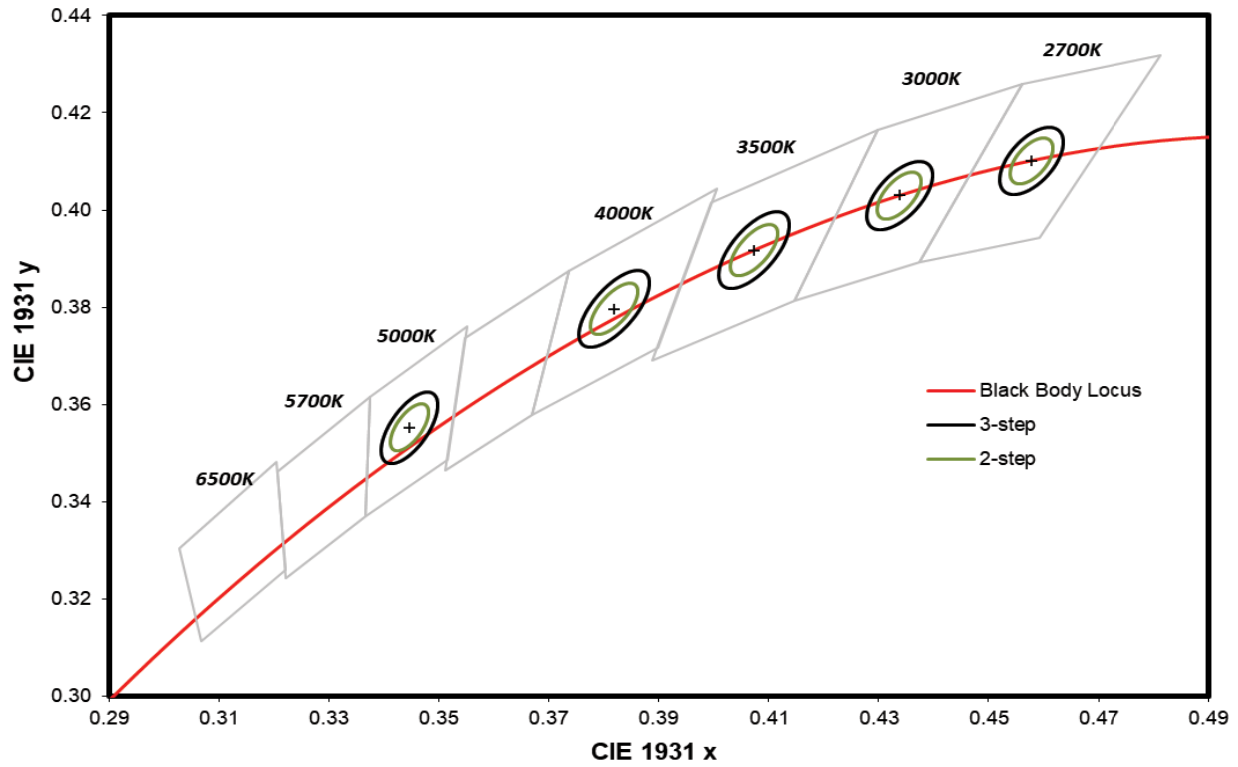

Figure 7. 2-step and 3-step MacAdam ellipse illustration for Table 5.

Table 5. 2-step and 3-step MacAdam ellipse color bin definitions for LUXEON CoB Core Range.

NOMINAL CCT	COLOR SPACE	CENTER POINT ^[1] (cx, cy)	MAJOR AXIS, a		MINOR AXIS, b		ELLIPSE ROTATION ANGLE, θ
			2-step	3-step	2-step	3-step	
2700K	2-step, 3-step MacAdam ellipse	(0.4578, 0.4101)	0.00540	0.00810	0.00280	0.00420	53.70°
3000K	2-step, 3-step MacAdam ellipse	(0.4338, 0.4030)	0.00556	0.00834	0.00272	0.00408	53.22°
3500K	2-step, 3-step MacAdam ellipse	(0.4073, 0.3917)	0.00618	0.00927	0.00276	0.00414	54.00°
4000K	2-step, 3-step MacAdam ellipse	(0.3818, 0.3797)	0.00626	0.00939	0.00268	0.00402	53.72°
5000K	2-step, 3-step MacAdam ellipse	(0.3447, 0.3553)	0.00548	0.00822	0.00236	0.00354	59.62°

Notes for Table 5:

1. Lumileds maintains a tolerance of ± 0.005 on x and y coordinates in the CIE 1931 color space.

Mechanical Dimensions

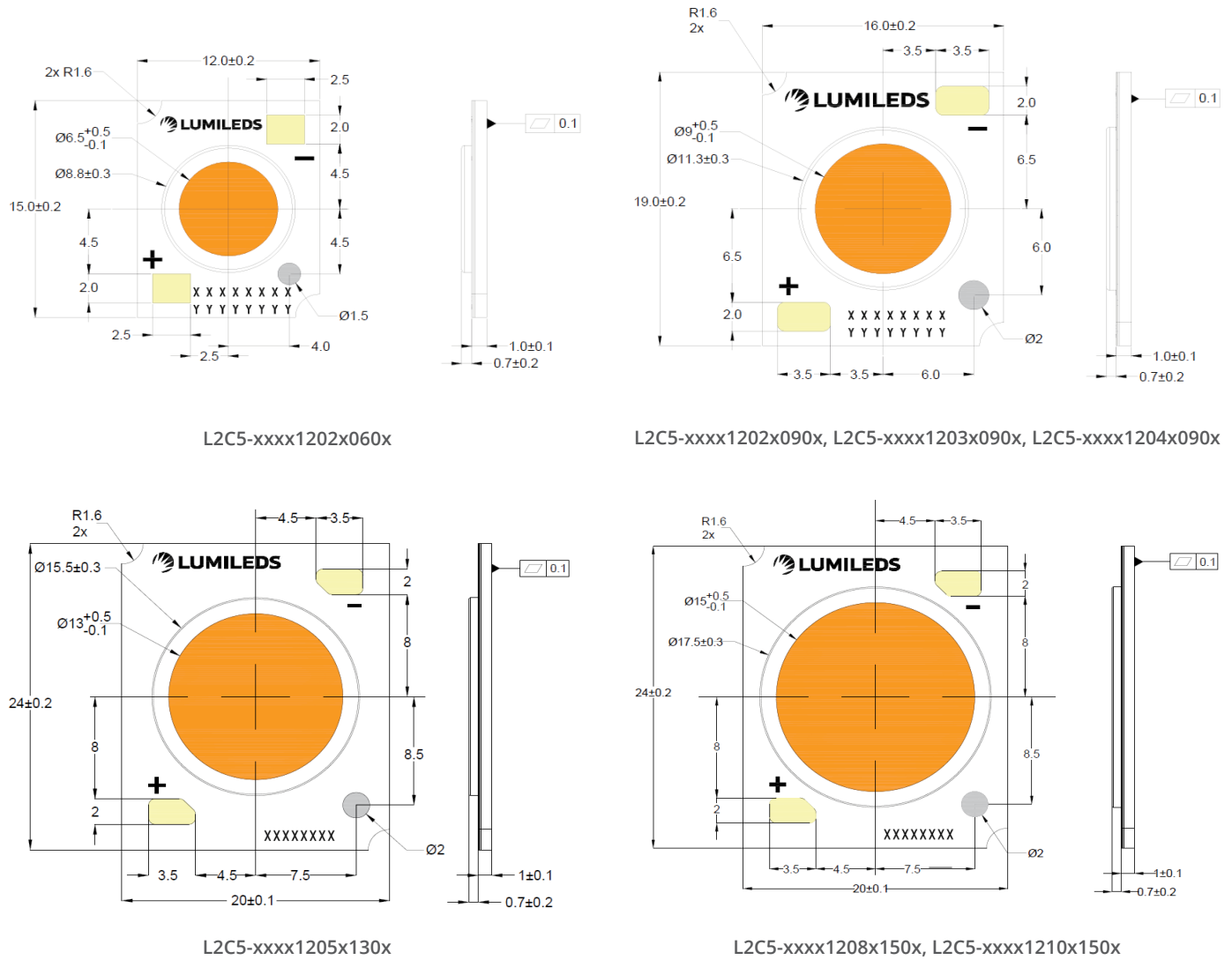

Figure 8. Mechanical dimensions for LUXEON CoB Core Range.

Notes for Figure 8:

1. Drawings not to scale.
2. All dimensions are in millimeters.
3. Dam heights: 0.7mm is applicable to L2C5-xx90xxxxxxxxx.

Packaging and Labeling Information

LUXEON CoB Core Range LEDs are packaged in tubes then in a carton box. Each tube contains a specified number of LEDs. The LEDs in each tube come from a single category code, ensuring they are all well-matched for light output, color, and forward voltage. Each tube contains a rubber stopper at one end. The tube label has both alphanumeric and bar code information. The carton boxes have printed information providing part numbers with CAT codes that indicate luminous flux, color and forward voltage bins.

Table 6. Number of LEDs per tube for LUXEON CoB Core Range.

PART NUMBER	TOTAL UNITS PER TUBE	TOTAL TUBES PER INNER BOX	TOTAL UNITS PER INNER BOX
L2C5-xxxx1202x060x	20	5	100
L2C5-xxxx1202x090x	20	5	100
L2C5-xxxx1203x090x	20	5	100
L2C5-xxxx1204x090x	20	5	100
L2C5-xxxx1205x130x	20	5	100
L2C5-xxxx1208x150x	20	5	100
L2C5-xxxx1210x150x	20	5	100

Tube

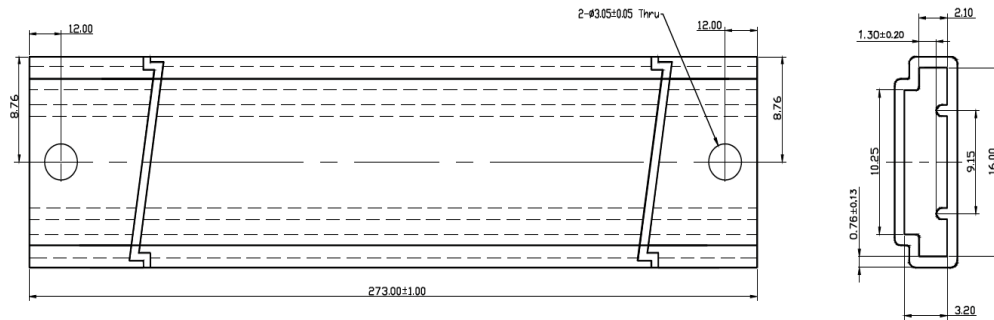

Figure 9a. Tube dimensions for L2C5-xxxx1202x060x.

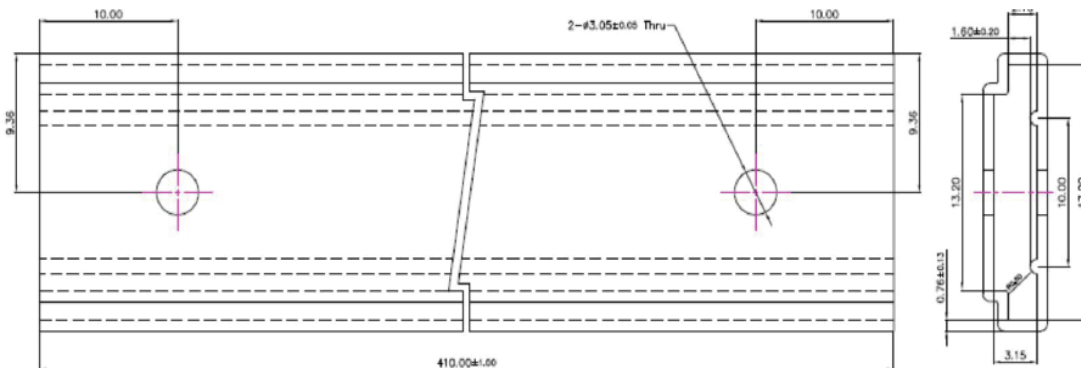

Figure 9b. Tube dimensions for L2C5-xxxx1202x090x, L2C5-xxxx1203x090x and L2C5-xxxx1204x090x.

Notes for Figures 9a and 9b:

1. Drawings not to scale.
2. All dimensions are in millimeters.

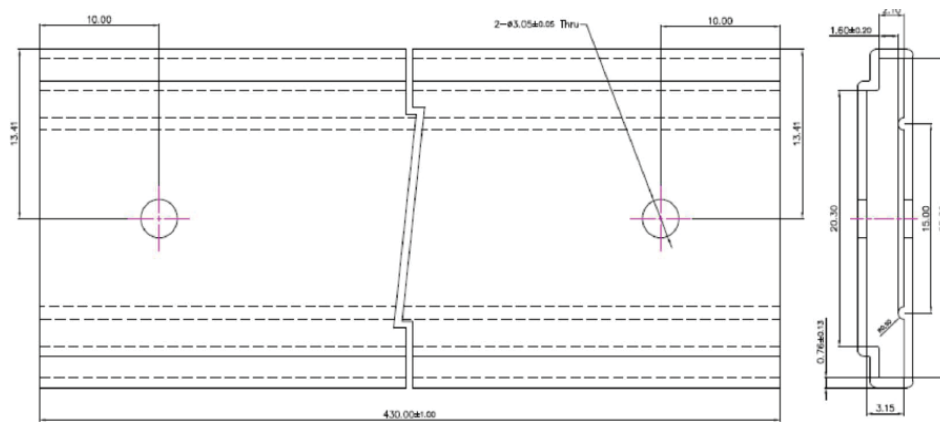

Figure 9c. Tube dimensions for L2C5-xxxx1205x130x, L2C5-xxxx1208x150x and L2C5-xxxx1210x150x.

Notes for Figure 9c:

1. Drawings not to scale.
2. All dimensions are in millimeters.

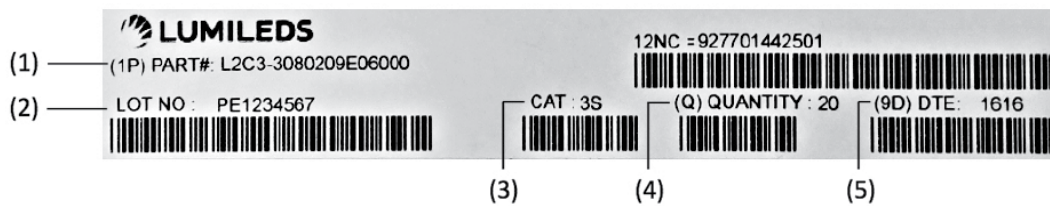

Figure 10. Example of a tube label for LUXEON CoB Core Range.

Notes for Figure 10 - Tube Label descriptions for customer use:

Field labels not described are for Lumileds internal use only.

1. Lumileds part number.
2. Unique production lot identification number. This number is required for traceability purpose.
3. Product category code.
4. Number of LED emitters in a tube.
5. LED test date in YYYY format.

Inner Box

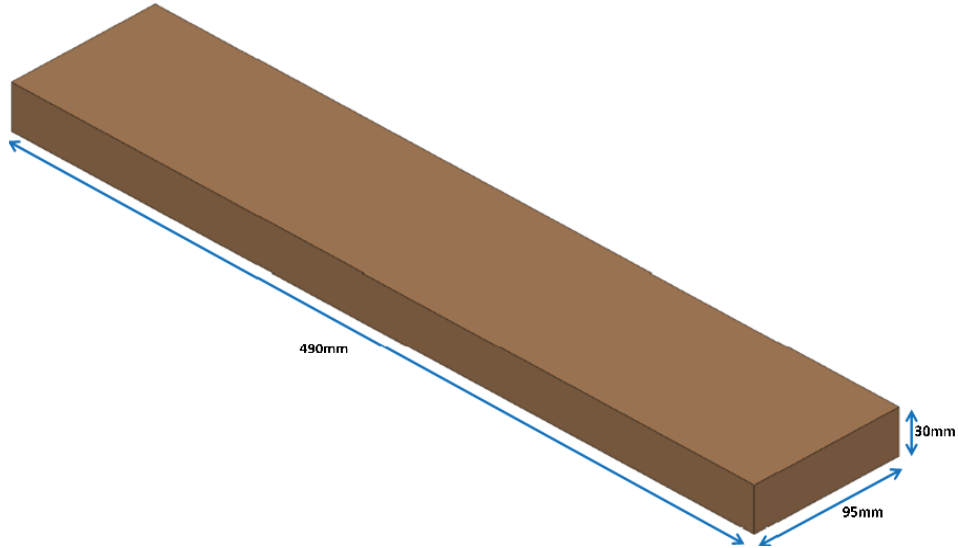

Figure 11. Dimensions for inner box packaging for LUXEON CoB Core Range.

Table 7. Inner box information for LUXEON CoB Core Range.

BOX TYPE	DIMENSIONS (mm)			AVERAGE WEIGHT (100pcs/box)	AVERAGE WEIGHT (50pcs/box)
	H	L	W		
Inner Box	30	490	95	0.340Kg	0.305Kg

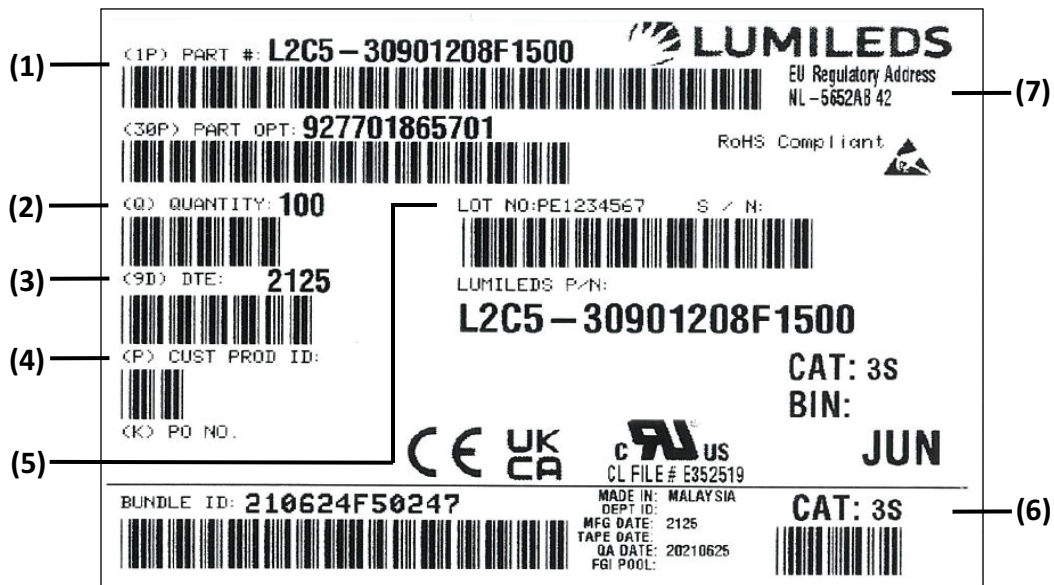

Figure 12. Example of inner box label for LUXEON CoB Core Range.

Notes for Figure 12 – Inner Box Label descriptions for customer use:
Field labels not described are for Lumileds internal use only.

1. Lumileds part number.
2. Number of LED emitters in a box.
3. LED test date in YYWW format.
4. Customer part number for custom requests only.
5. Unique production lot identification number. This number is required for traceability purpose.
6. Product category code.
7. EU regulatory address.

Outer Box

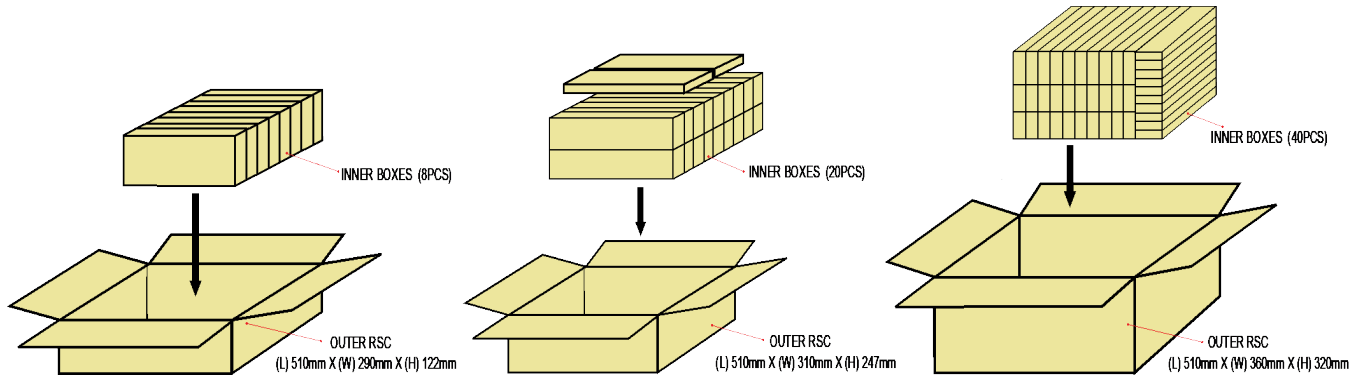

Figure 13. Dimensions for outer box packaging for LUXEON CoB Core Range.

Table 8. Outer box information for LUXEON CoB Core Range.

BOX TYPE	DIMENSIONS (mm)			MAXIMUM INNER BOXES PER OUTER BOX	MAXIMUM QUANTITY PER OUTER BOX	AVERAGE WEIGHT (100pcs/box)	AVERAGE WEIGHT (50pcs/box)
	H	L	W				
Outer Box 8	122	510	290	8	800	3.05kg	2.77kg
Outer Box 20	247	510	310	20	2000	7.55kg	6.85kg
Outer Box 40	320	510	360	40	4000	15.10kg	13.70kg



Figure 14. Example of outer box label for LUXEON CoB Core Range.

Notes for Figure 14 – Outer Box Label descriptions for customer use:

Field labels not described are for Lumileds internal use only.

1. Country code of origin of manufacturing of parts (e.g. MY for Malaysia, CN for China) according to ISO 3166-1 alpha-2 document.
2. Lumileds part number.
3. Customer part number for custom requests only.
4. Total number of LED emitters in a shipment box.

About Lumileds

Companies developing automotive, mobile, IoT and illumination lighting applications need a partner who can collaborate with them to push the boundaries of light. With over 100 years of inventions and industry firsts, Lumileds is a global lighting solutions company that helps customers around the world deliver differentiated solutions to gain and maintain a competitive edge. As the inventor of Xenon technology, a pioneer in halogen lighting and the leader in high performance LEDs, Lumileds builds innovation, quality and reliability into its technology, products and every customer engagement. Together with its customers, Lumileds is making the world better, safer, more beautiful—with light.

To learn more about our lighting solutions, visit lumileds.com.



©2024 Lumileds Holding B.V. All rights reserved.
LUXEON is a registered trademark of the Lumileds Holding B.V. in the United States and other countries.

lumileds.com

Neither Lumileds Holding B.V. nor its affiliates shall be liable for any kind of loss of data or any other damages, direct, indirect or consequential, resulting from the use of the provided information and data. Although Lumileds Holding B.V. and/or its affiliates have attempted to provide the most accurate information and data, the materials and services information and data are provided “as is,” and neither Lumileds Holding B.V. nor its affiliates warrants or guarantees the contents and correctness of the provided information and data. Lumileds Holding B.V. and its affiliates reserve the right to make changes without notice. You as user agree to this disclaimer and user agreement with the download or use of the provided materials, information and data. A listing of Lumileds product/patent coverage may be accessed at lumileds.com/patents.

X-ON Electronics

Largest Supplier of Electrical and Electronic Components

Click to view similar products for Lumileds manufacturer:

Other Similar products are found below :

[A1DL-O612L12U3AF00](#) [A1DT-O612L1153AC00](#) [L128-1890HA35000B1](#) [L128-1890NA3500001](#) [L128-2280HA3500001](#) [L128-2280NA3500001](#) [L128-2290NA3500001](#) [L128-2770SA35A00E1](#) [L128-2770SA35A00F1](#) [L128-2780CA3500001](#) [L128-2780CB3500001](#) [L128-2780EA3500001](#) [L128-2780EA3500005](#) [L128-2780EC35000B1](#) [L128-2780SA35A00G1](#) [L128-2780SA35A0DF1](#) [L128-2790CA3500001](#) [L128-2790EC35000B1](#) [L128-2790HA35000K1](#) [L128-2790NA3500001](#) [L128-2790SA35A00G1](#) [L128-2790SA35A0DF1](#) [L128-3070SA35A00E1](#) [L128-3070SA35A00F1](#) [L128-3080003500000](#) [L128-3080CA3500001](#) [L128-3080CB3500001](#) [L128-3080EA3500001](#) [L128-3080EB3500001](#) [L128-3080HA3500001](#) [L128-3080HA35000H1](#) [L128-3080SA35A00G1](#) [L128-3090EA3500001](#) [L128-3090HA35000K1](#) [L128-3090NA3500001](#) [L128-3090SA35A00G1](#) [L128-3095HA3500001](#) [L128-3570SA35A00E1](#) [L128-3570SA35A00F1](#) [L128-3580CA3500001](#) [L128-3580EA3500001](#) [L128-3580EA3500004](#) [L128-3580SA35A00G1](#) [L128-3590EC3500001](#) [L128-3590HA35000K1](#) [L128-3590NA3500001](#) [L128-3590SA35A00G1](#) [L128-3595HA35000B1](#) [L128-4070HA35000H1](#) [L128-4070SA35A00E1](#)