

Breakover Diode Gen² (BOD2)

 $V_{BO} = 400-1400 \text{ V}$
 $I_{AVM} = 0.9 \text{ A}$

| V_{BO} [V] | Standard Types |
|-----------------|----------------|
| 400 ±50 | IXBOD2-04 |
| 500 ±50 | IXBOD2-05 |
| 600 ±50 | IXBOD2-06 |
| 700 ±50 | IXBOD2-07 |
| 800 ±50 | IXBOD2-08 |
| 900 ±50 | IXBOD2-09 |
| 1000 ±50 | IXBOD2-10 |
| 1100 ±50 | IXBOD2-11 |
| 1200 ±50 | IXBOD2-12 |
| 1300 ±50 | IXBOD2-13 |
| 1400 ±50 | IXBOD2-14 |

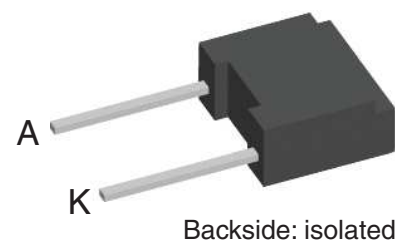

Features / Advantages:

- Extra fast turn-on
- Very low temperature dependence
- Very low leakage current

Applications:

- High voltage circuit protection
- Transient voltage protection
- Trigger device
- Power pulse generators
- Lightning and arcing protection
- Energy discharge circuits
- Battery overvoltage protection
- Solar array protection

Package: FP-Case

- Industry standard outline
- RoHS compliant
- Epoxy meets UL 94V-0
- Soldering pins for PCB mounting
- Base plate: Plastic overmolded tab
- Reduced weight

Disclaimer Notice

Information furnished is believed to be accurate and reliable. However, users should independently evaluate the suitability of and test each product selected for their own applications. Littelfuse products are not designed for, and may not be used in, all applications. Read complete Disclaimer Notice at www.littelfuse.com/disclaimer-electronics.

| BOD2 | | | Ratings | | | |
|----------------|---|--|---------|------|------------------------|--------------------------|
| Symbol | Definitions | Conditions | min. | typ. | max. | |
| I_D | drain current | $V_D = 0.8 \cdot V_{BO}$ | | | 10 200 | μA μA |
| V_{BO} | breakover voltage | $V_{BO}(T_{VJ}) = V_{BO, 25^\circ C} [1 + K_T (T_{VJ} - 25^\circ C)]$ | | | | V |
| I_{RMS} | RMS current | f = 50 Hz pins soldered to printed circuit (conductor 0.035x2mm) | | | 1.4 | A |
| I_{FAVM} | maximum average forward current | | | | 0.9 | A |
| I_{SM} | maximum pulsed source current | $t_p = 0.1$ ms; non repetitive | | | 250 | A |
| I^2t | I^2t value for fusing | $t_p = 0.1$ ms | | | 3.1 | A ² s |
| K_T | temperature coefficient of V_{BO} | | | | 0.7 · 10 ⁻³ | K ⁻¹ |
| K_P | coefficient for energy per pulse EP (material constant) | | | | 700 | K/Ws |
| R_{thJA} | thermal resistance junction to ambient | natural convection with air speed 2 m/s | | | 60 45 | K/W K/W |
| I_{BO} | breakover current | | | | 15 6 | mA mA |
| I_H | holding current | | | | 20 12 | mA mA |
| V_H | holding voltage | | 4 | | 8 | V |
| $(dv/dt)_{cr}$ | critical rate of rise of voltage | $V_D = 0.9 \cdot V_{BO}$ | | | 3000 1000 | V/ μs V/ μs |
| $(di/dt)_{cr}$ | critical rate of rise of current | $I_T = 100$ A; $V_D = V_{BO}$; f = 50 Hz $I_T = 600$ A; non repetitive | | | 200 500 | A/ μs A/ μs |
| t_q | turn-off time | $V_D = 0.75 \cdot V_{BO}$; $V_R = 0$ V; $I_T = 100$ A $dv/dt_{(lin.)} = 5000$ V/ μs ; $di/dt = -500$ A/ μs | | 200 | | μs |
| V_T | forward voltage drop | $I_T = 10$ A | | | 1.3 1.2 | V V |
| V_{T0} | threshold voltage | | | | 0.75 | V |
| r_T | slope resistance | for power-loss calculation only | | | 0.05 | Ω |

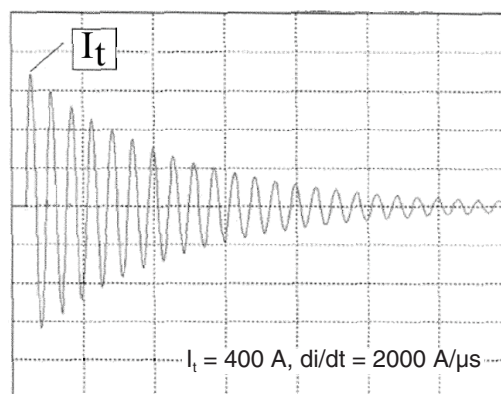
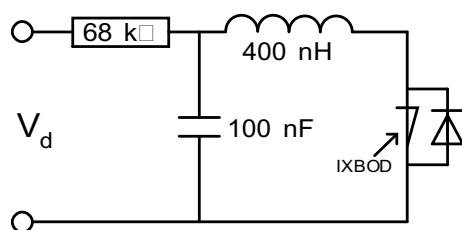

| Package FP-Case | | | Ratings | | | |
|-----------------|--------------------------------------|------------|---------|------|------|----|
| Symbol | Definitions | Conditions | min. | typ. | max. | |
| T_{amb} | ambient temperature (cooling medium) | | -40 | | 150 | °C |
| T_{stg} | storage temperature | | -40 | | 150 | °C |
| T_{vJM} | maximum virtual junction temperature | | -40 | | 150 | °C |
| Weight | | | | 0.9 | | g |

Product Marking

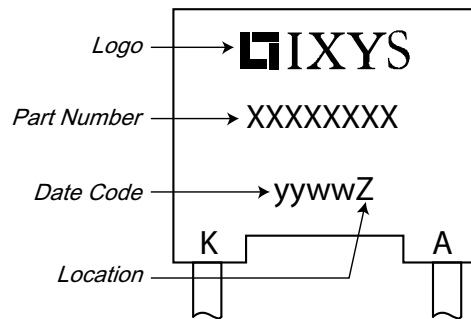

| Ordering | Part Name | Marking on Product | Delivering Mode | Base Qty | Ordering Code |
|----------|-----------|--------------------|-----------------|----------|---------------|
| Standard | IXBOD2-04 | IXBOD2-04 | Box | 100 | 511174 |
| Standard | IXBOD2-05 | IXBOD2-05 | Box | 100 | tbd |
| Standard | IXBOD2-06 | IXBOD2-06 | Box | 100 | tbd |
| Standard | IXBOD2-07 | IXBOD2-07 | Box | 100 | 508425 |
| Standard | IXBOD2-08 | IXBOD2-08 | Box | 100 | 507602 |
| Standard | IXBOD2-09 | IXBOD2-09 | Box | 100 | 511668 |
| Standard | IXBOD2-10 | IXBOD2-10 | Box | 100 | 508078 |
| Standard | IXBOD2-11 | IXBOD2-11 | Box | 100 | 511860 |
| Standard | IXBOD2-12 | IXBOD2-12 | Box | 100 | 511675 |
| Standard | IXBOD2-13 | IXBOD2-13 | Box | 100 | 511682 |
| Standard | IXBOD2-14 | IXBOD2-14 | Box | 100 | 509782 |

Outlines FP-case

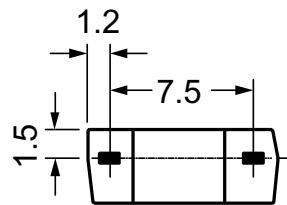
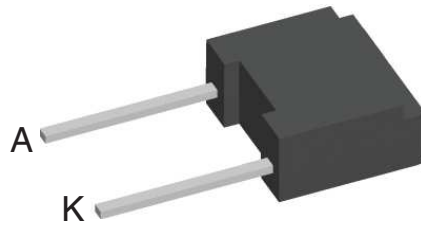

Dimensions in mm
(1 mm = 0.0394")

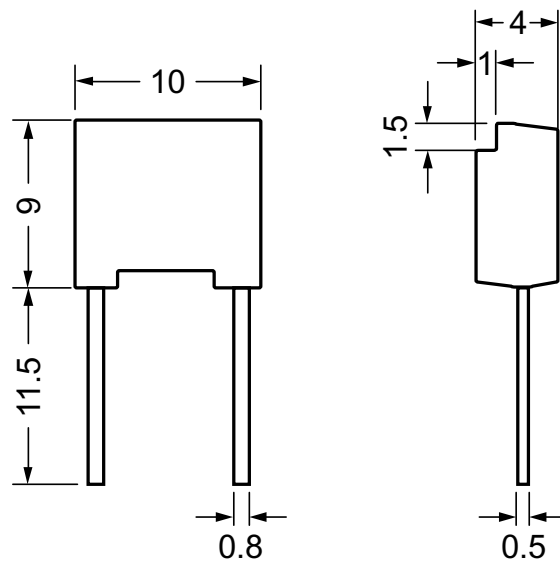

X-ON Electronics

Largest Supplier of Electrical and Electronic Components

Click to view similar products for [Diodes - General Purpose, Power, Switching category](#):

Click to view products by [IXYS manufacturer](#):

Other Similar products are found below :

[RD0306T-H](#) [BAQ33-GS18](#) [BAV17-TR](#) [BAV19-TR](#) [1N3611](#) [NTE156A](#) [NTE525](#) [NTE571](#) [NTE574](#) [NTE5804](#) [NTE5806](#) [NTE6244](#)
[1SS181-TP](#) [1SS193,LF](#) [1SS400CST2RA](#) [SDAA13](#) [SHN2D02FUTW1T1G](#) [LS4151GS08](#) [1N4449](#) [1N456A](#) [1N4934-E3/73](#) [1N914B](#)
[1N914BTR](#) [RFUH20TB3S](#) [BAS 28 E6327](#) [BAV199-TP](#) [BAW56DWQ-7-F](#) [BAW75-TAP](#) [MM230L-CAA](#) [IDW40E65D1](#) [LL4151-GS18](#)
[053684A](#) [SMMSD4148T3G](#) [707803H](#) [SP000010217](#) [ACDSW4448-HF](#) [CDSZC01100-HF](#) [BAV199E6433HTMA1](#) [BAV70M3T5G](#)
[SMBT2001T1G](#) [NTE5801](#) [NTE5800](#) [NTE5808](#) [NTE6240](#) [NTE6248](#) [DLM10C-AT1](#) [BAS28-7](#) [BAW56HDW-13](#) [BAS28 TR](#) [VS-](#)
[HFA04SD60STR-M3](#)