

CoolSET[®]-F3R80

ICE3AR4780CJZ

Off-Line SMPS Current Mode
Controller with integrated 800V
CoolMOS[®] and Startup cell
(brownout & CCM) in DIP-7

Power Management & Supply



Never stop thinking.

CoolSET®-F3R80

ICE3AR4780CJZ

Revision History:

2013-04-19

Datasheet Version 2.0

Previous Version: V 0.1

For questions on technology, delivery and prices please contact the Infineon Technologies Offices in Germany or the Infineon Technologies Companies and Representatives worldwide: see our webpage at <http://www.infineon.com>

CoolMOS®, CoolSET® are trademarks of Infineon Technologies AG.

Edition 2013-04-19

**Published by
Infineon Technologies AG
81726 München, Germany**

**© Infineon Technologies AG 4/19/13.
All Rights Reserved.**

Attention please!

The information given in this data sheet shall in no event be regarded as a guarantee of conditions or characteristics ("Beschaffheitsgarantie"). With respect to any examples or hints given herein, any typical values stated herein and/or any information regarding the application of the device, Infineon Technologies hereby disclaims any and all warranties and liabilities of any kind, including without limitation warranties of non-infringement of intellectual property rights of any third party.

Information

For further information on technology, delivery terms and conditions and prices please contact your nearest Infineon Technologies Office (www.infineon.com).

Warnings

Due to technical requirements components may contain dangerous substances. For information on the types in question please contact your nearest Infineon Technologies Office.

Infineon Technologies Components may only be used in life-support devices or systems with the express written approval of Infineon Technologies, if a failure of such components can reasonably be expected to cause the failure of that life-support device or system, or to affect the safety or effectiveness of that device or system. Life support devices or systems are intended to be implanted in the human body, or to support and/or maintain and sustain and/or protect human life. If they fail, it is reasonable to assume that the health of the user or other persons may be endangered.

Off-Line SMPS Current Mode Controller with integrated 800V CoolMOS[®] and Startup cell (brownout & CCM) in DIP-7

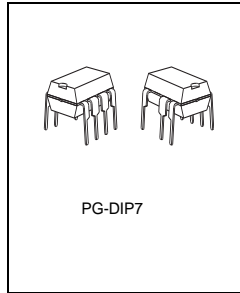

Product Highlights

- 800V avalanche rugged CoolMOS[®] with startup cell
- CCM and DCM operation with slope compensation
- Active Burst Mode to reach the lowest Standby Power <100mW
- Active burst mode with selectable entry and exit burst mode level
- Frequency jitter and soft driving for low EMI
- Brownout feature
- Latch enable and fast AC reset
- Auto Restart protection for over load, over temperature and over voltage
- Pb-free lead plating; RoHS compliant

Features

- 800V avalanche rugged CoolMOS[®] with Startup Cell
- Active Burst Mode for lowest Standby Power
- Slope compensation for CCM operation
- Selectable entry and exit burst mode level
- 100kHz internally fixed switching frequency with jittering feature
- Auto Restart Protection for Over load, Open Loop, VCC Under voltage & Over voltage and Over temperature
- External latch enable pin and fast AC reset
- Over temperature protection with 50°C hysteresis
- Built-in 10ms Soft Start
- Built-in 40ms blanking time for short duration peak power
- Propagation delay compensation for both maximum load and burst mode
- Brownout feature
- BiCMOS technology for low power consumption and wide VCC voltage range
- Soft gate drive with 50Ω turn on resistor

Description

The ICE3ARxx80CJZ is an enhanced version of ICE3ARxx80JZ (CoolSET[®]-F3R80). The PWM controller is based on F3R80 with new and enhanced features. The major new features include slope compensation for CCM operation and fast AC reset after latch enabled. The major enhanced features include fixed voltage brownout detect and voltage detect for the burst selection. In particular it is a device running at 100kHz, implemented with brownout features, installing 800V CoolMOS[®] with startup cell and packaged into DIP-7. It targets for the low power SMPS with increased MOSFET voltage margin requirement such as Off-Line battery adapters, DVD R/W, DVD Combi, Blue ray, set top box, auxiliary power supply for PC and server, etc. In summary, this enhanced ICE3ARxx80CJZ provides 800V MOSFET, lowest standby power, CCM operation, selectable burst level, brownout feature, maximum power compensated for both maximum and standby load, low EMI with frequency jittering and soft gate drive, built-in and flexible protections, etc. Therefore, ICE3ARxx80CJZ is a complete solution for the low power SMPS application.

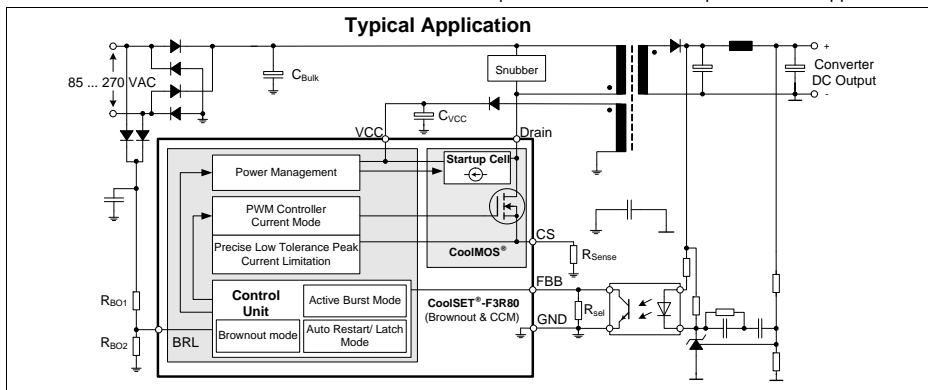

Type	Package	Marking	V _{DS}	F _{OSC}	R _{DSon} ⁽¹⁾	230VAC ±15% ⁽²⁾	85-265 VAC ⁽²⁾
ICE3AR4780CJZ	PG-DIP-7	3AR4780CJZ	800V	100kHz	4.7Ω	31W	20W

¹⁾ typ @ T=25°C

²⁾ Calculated maximum input power rating at T_a=50°C, T_j=125°C and without copper area as heat sink.

Table of Contents		Page
1	Pin Configuration and Functionality	6
1.1	Pin Configuration with PG-DIP-7	6
1.2	Pin Functionality	6
2	Representative Blockdiagram	7
3	Functional Description	8
3.1	Introduction	8
3.2	Power Management	8
3.3	Improved Current Mode	9
3.3.1	PWM-OP	10
3.3.2	PWM-Comparator	10
3.3.3	Slope Compensation	10
3.4	Startup Phase	11
3.5	PWM Section	12
3.5.1	Oscillator	12
3.5.2	PWM-Latch FF1	12
3.5.3	Gate Driver	13
3.6	Current Limiting	13
3.6.1	Leading Edge Blanking	14
3.6.2	Combined OPP curve considering Propagation Delay and Slope Compensation 14	14
3.7	Control Unit	15
3.7.1	Active Burst Mode (patented)	15
3.7.1.1	Selectable burst entry level	15
3.7.1.2	Entering Active Burst Mode	16
3.7.1.3	Working in Active Burst Mode	16
3.7.1.4	Leaving Active Burst Mode	16
3.7.2	Protection Modes	17
3.7.2.1	Vcc OVP, OTP, external protection enable and Vcc under voltage ..	18
3.7.2.2	Over load, open loop protection	18
3.7.3	Brownout Mode	18
3.7.4	Fast AC reset	19
4	Electrical Characteristics	21
4.1	Absolute Maximum Ratings	21
4.2	Operating Range	22
4.3	Characteristics	22
4.3.1	Supply Section	22
4.3.2	Internal Voltage Reference	23
4.3.3	PWM Section	23
4.3.4	Soft Start time	23
4.3.5	Control Unit	24
4.3.6	Current Limiting	25

4.3.7	CoolMOS® Section	25
5	CoolMOS® Performance Characteristic	26
6	Input Power Curve	28
7	Outline Dimension	29
8	Marking	30
9	Schematic for recommended PCB layout	31

1 Pin Configuration and Functionality

1.1 Pin Configuration with PG-DIP-7

Pin	Symbol	Function
1	BRL	Brownout, fast AC Reset & Latch enable
2	FBB	Feedback & Burst entry/exit control
3	CS	Current Sense/ 800V CoolMOS® Source
4	n.c.	not connected
5	Drain	800V CoolMOS® Drain
6	-	(no pin)
7	VCC	Controller Supply Voltage
8	GND	Controller Ground

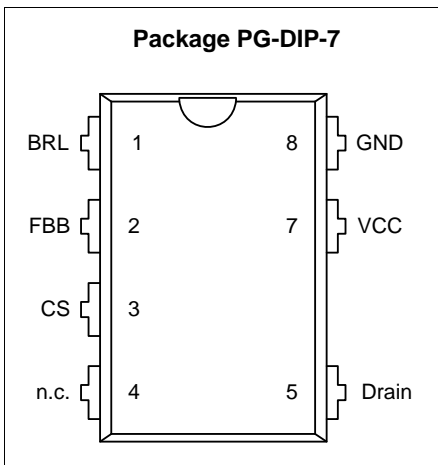

Figure 1 Pin Configuration PG-DIP-7 (top view)

1.2 Pin Functionality

BRL (Brownout, fast AC Reset & Latch enable)

The BRL pin combines the functions of brownout, fast AC reset and the external latch enable. The brownout feature is to stop the switching pulse when the input voltage is dropped to lower than 1V. The Fast AC reset feature is to recover from latch feature when the voltage of BRL pin has a rising rate of <math><1.33\text{V/ms}</math> from 0.4V to 1V. The external latch enable function is an external access to stop the gate switching and force the IC to enter latch mode. It is triggered by pulling the pin voltage to less than 0.4V.

FBB (Feedback & Burst entry select)

The FBB pin combines the feedback function and the burst entry/exit control. The regulation information is provided by the FBB pin to the internal Protection Unit and the internal PWM-Comparator to control the duty cycle. The FBB-signal is the only control signal in case of light load at the Active Burst Mode. The burst entry select provides an access to select the entry/exit burst mode level.

CS (Current Sense)

The Current Sense pin senses the voltage developed on the shunt resistor inserted in the source of the integrated CoolMOS®. If CS reaches the internal threshold of the Current Limit Comparator, the Driver output is immediately switched off. Furthermore the current information is provided for the PWM-Comparator to realize the Current Mode operation.

Drain (Drain of integrated CoolMOS®)

The Drain pin is the connection to the Drain of the integrated CoolMOS®.

VCC (Power Supply)

The VCC pin is the power supply of the IC. The voltage operating range is between 10.5V and 24.7V.

GND (Ground)

The GND pin is the ground of the controller.

2 Representative Blockdiagram

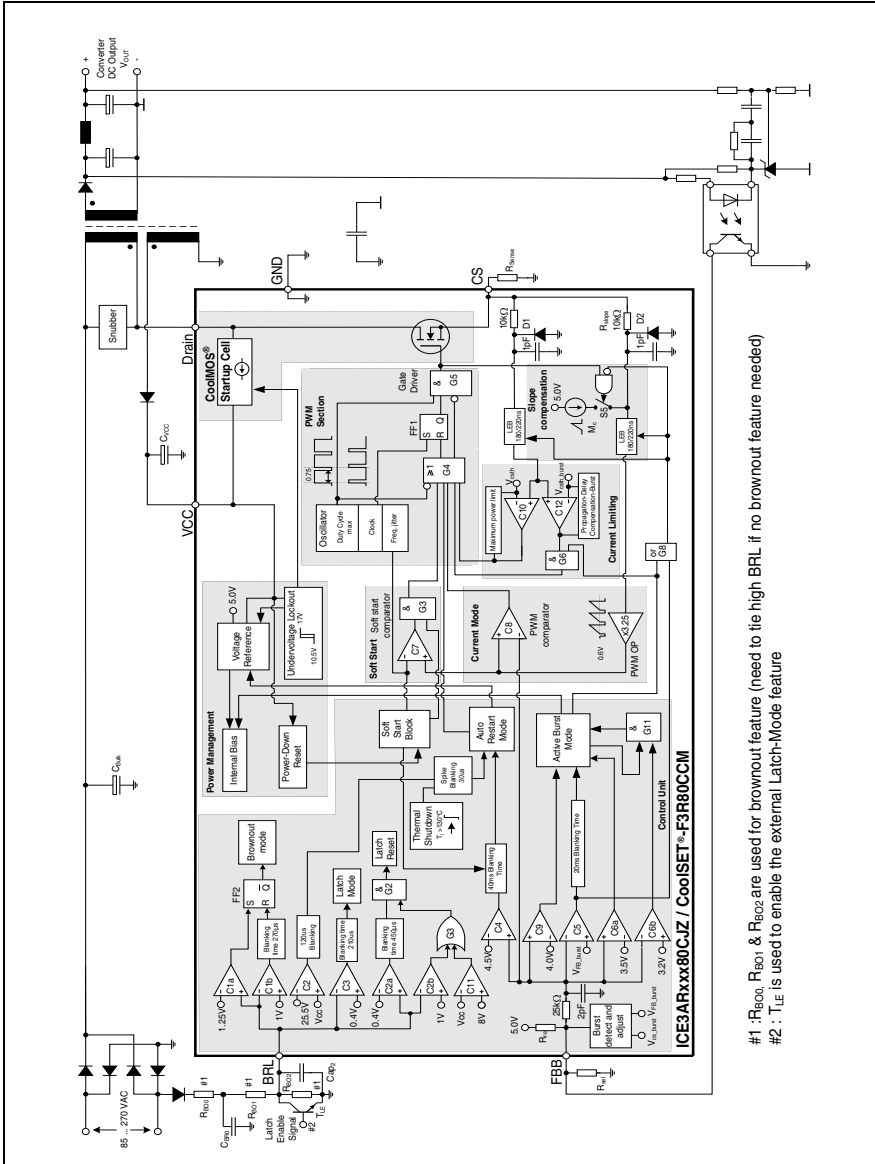

#1: R_{B00} , R_{B01} & R_{B02} are used for brownout feature (need to tie high BRL if no brownout feature needed)
 #2: T_{LE} is used to enable the external Latch-Mode feature

Figure 2 Representative Blockdiagram

3 Functional Description

All values which are used in the functional description are typical values. For calculating the worst cases the min/max values which can be found in section 4 Electrical Characteristics have to be considered.

3.1 Introduction

ICE3ARxx80CJZ brownout and CCM 800V version is an enhanced version of the CoolSET®-F3R80. The major new and enhanced features include slope compensation for CCM operation, fast AC reset after latch enabled, fixed voltage brownout detect and voltage detect for the burst selection. It is particular good for high voltage margin low power SMPS application such as auxiliary power supply for PC and server. The major characteristics are that the IC is developed with 800V CoolMOS® with start up cell, having adjustable brownout feature, running at 100KHz switching frequency, CCM operation and packed in DIP-7 package.

The features include BiCMOS technology to reduce power consumption and increase the Vcc voltage range, cycle by cycle current mode control, built-in 10ms soft start to reduce the stress of switching elements during start up, built-in 40ms for short period of peak power before entering protection, active burst mode for lowest standby power, propagation delay compensation for close power limit between high line and low line which also takes into consideration of slope compensation, frequency jittering for low EMI performance, the built-in auto-restart mode protections for open loop, over load, Vcc OVP, Vcc under voltage, and latch enable feature etc.

The other features include narrowing the feedback voltage swing to 0.3V (from 0.5V) during burst mode so that the output voltage ripple can be reduced by 40%, reduction of the fast voltage fall time of the MOSFET by increasing the soft turn-on time and addition of 50Ω turn-on resistor, faster start up time by optimizing the Vcc capacitor to 10μF and over temperature protection with 50°C hysteresis.

The new features include slope compensation for stable operation in CCM mode when duty is larger than 0.5, fixed voltage triggering for the brownout feature for easier design, voltage levels select for entry/exit burst level, fast AC reset fto reset the latch feature, etc.

In summary, the CoolSET® ICE3ARxx80CJZ provides good voltage margin of MOSFET, lowest standby power, flexible burst level, CCM operation, reduced output ripple during burst mode, accurate power limit for both maximum power and burst power, low EMI with frequency jittering and soft gate drive, built-in and flexible protections, etc. Therefore, CoolSET® ICE3ARxx80CJZ is a complete solution for the low power SMPS application.

3.2 Power Management

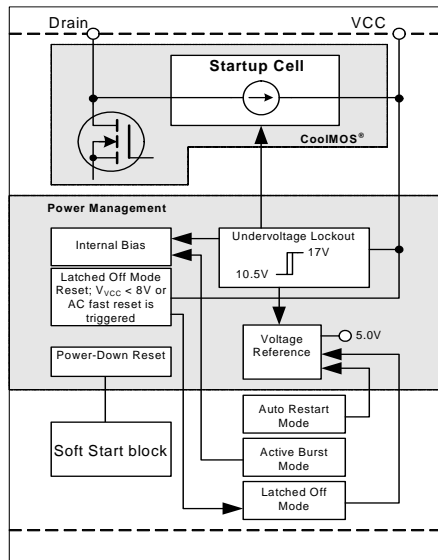

Figure 3 Power Management

The Undervoltage Lockout monitors the external supply voltage V_{VCC}. When the SMPS is plugged to the main line the internal Startup Cell is biased and starts to charge the external capacitor C_{VCC} which is connected to the VCC pin. This VCC charge current is controlled to 1.0mA by the Startup Cell. When the V_{VCC} exceeds the on-threshold V_{CCon}=17V the bias circuit are switched on. Then the Startup Cell is switched off by the Undervoltage Lockout and therefore no power losses present due to the connection of the Startup Cell to the Drain voltage. To avoid uncontrolled ringing at switch-on, a hysteresis start up voltage is implemented. The switch-off of the controller can only take place when V_{VCC} falls below 10.5V after normal operation was entered. The maximum current consumption before the controller is activated is about 210μA.

When V_{VCC} falls below the off-threshold V_{CCoff}=10.5V, the bias circuit is switched off and the soft start counter is reset. Thus it ensures that at every startup cycle the soft start starts at zero.

The internal bias circuit is switched off if Latched Off Mode or Auto Restart Mode is entered. The current consumption is then reduced to 420μA.

Once the malfunction condition is removed, this block will then turn back on. The recovery from Auto Restart Mode does not require re-cycling the AC line. In case Latched Off Mode is entered, VCC needs to be lowered below 8V or having AC fast reset triggered to reset the

Functional Description

Latched Off Mode. This is done usually by re-cycling the AC line.

When Active Burst Mode is entered, the internal Bias is switched off most of the time but the Voltage Reference is kept alive in order to reduce the current consumption below 620µA.

3.3 Improved Current Mode

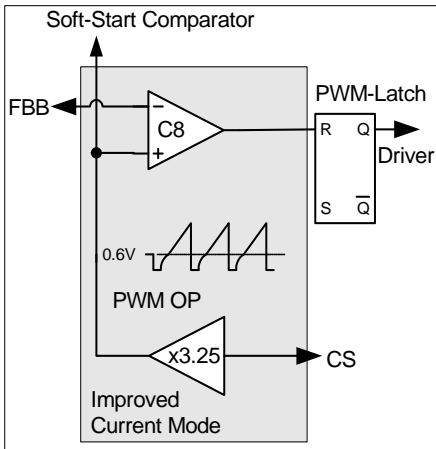

Figure 4 Current Mode

Current Mode means the duty cycle is controlled by the slope of the primary current. This is done by comparing the FBB signal with the amplified current sense signal.

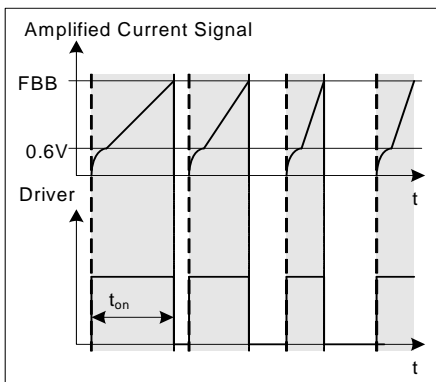

Figure 5 Pulse Width Modulation

In case the amplified current sense signal exceeds the FBB signal the on-time t_{on} of the driver is finished by resetting the PWM-Latch (Figure 5).

The primary current is sensed by the external series resistor R_{sense} inserted in the source of the integrated CoolMOS®. By means of Current Mode regulation, the secondary output voltage is insensitive to the line variations. The current waveform slope will change with the line variation, which controls the duty cycle.

The external R_{sense} allows an individual adjustment of the maximum source current of the integrated CoolMOS®.

To improve the Current Mode during light load conditions the amplified current ramp of the PWM-OP is superimposed on a voltage ramp, which is built by the switch T2, the voltage source V1 and a resistor R1 (see Figure 6). Every time the oscillator shuts down for maximum duty cycle limitation the switch T2 is closed by V_{osc} . When the oscillator triggers the Gate Driver, T2 is opened so that the voltage ramp can start.

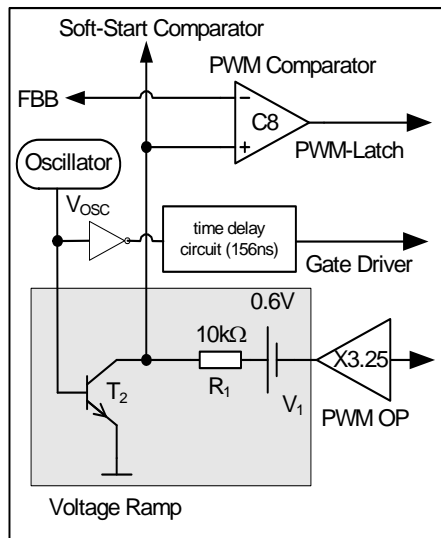

Figure 6 Improved Current Mode

In case of light load the amplified current ramp is too small to ensure a stable regulation. In that case the Voltage Ramp is a well defined signal for the comparison with the FBB-signal. The duty cycle is then controlled by the slope of the Voltage Ramp.

By means of the time delay circuit which is triggered by the inverted V_{osc} signal, the Gate Driver is switched-off until it reaches approximately 156ns delay time (Figure

3.4 Startup Phase

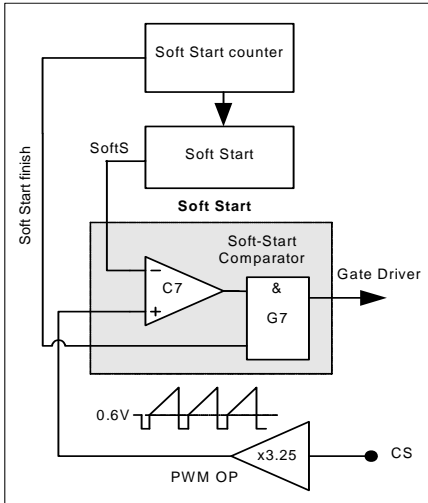

Figure 10 Soft Start

In the Startup Phase, the IC provides a Soft Start period to control the primary current by means of a duty cycle limitation. The Soft Start function is a built-in function and it is controlled by an internal counter.

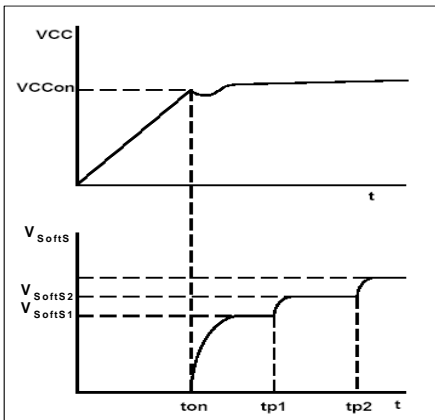

Figure 11 Soft Start Phase

When the V_{CC} exceeds the on-threshold voltage, the IC starts the Soft Start mode (Figure 11).

The function is realized by an internal Soft Start resistor, an current sink and a counter. And the amplitude of the current sink is controlled by the counter (Figure 12).

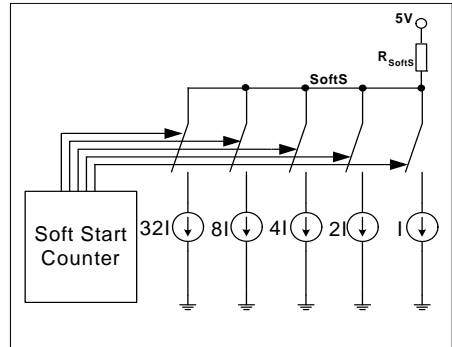

Figure 12 Soft Start Circuit

After the IC is switched on, the V_{SoftS} voltage is controlled such that the voltage is increased stepwisely (32 steps) with the increase of the counts. The Soft Start counter would send a signal to the current sink control in every $300\mu s$ such that the current sink decrease gradually and the duty ratio of the gate drive increases gradually. The Soft Start will be finished in $10ms$ ($t_{Soft-Start}$) after the IC is switched on. At the end of the Soft Start period, the current sink is switched off.

Within the soft start period, the duty cycle is increasing from zero to maximum gradually (see Figure 13).

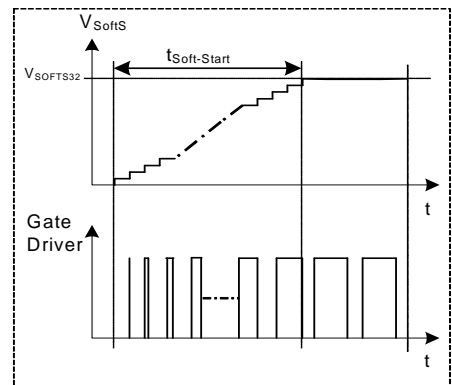

Figure 13 Gate drive signal under Soft-Start Phase

In addition to Start-Up, Soft-Start is also activated at each restart attempt during normal Auto Restart.

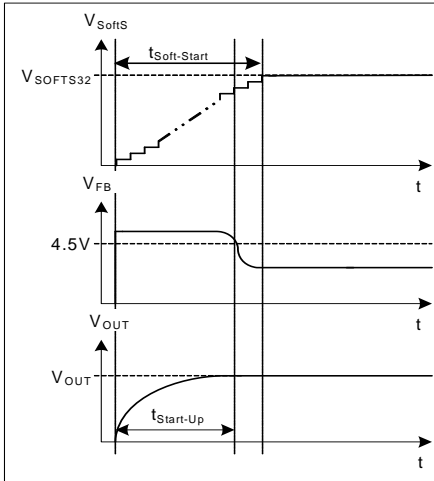

Figure 14 Start Up Phase

The Start-Up time $t_{Start-Up}$ before the converter output voltage V_{OUT} is settled, must be shorter than the Soft-Start Phase $t_{Soft-Start}$ (Figure 14). By means of Soft-Start there is an effective minimization of current and voltage stresses on the integrated CoolMOS®, the clamp circuit and the output rectifier and it helps to prevent saturation of the transformer during Start-Up.

3.5 PWM Section

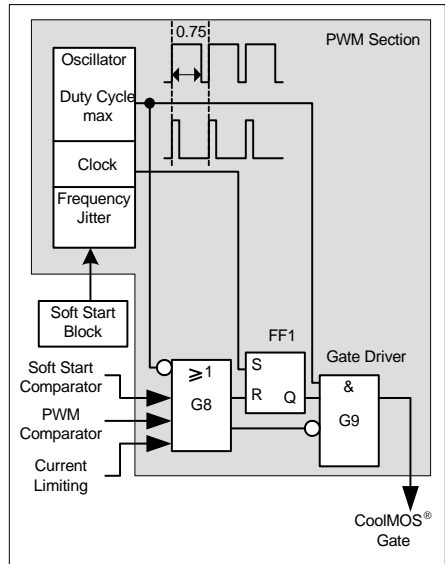

Figure 15 PWM Section Block

3.5.1 Oscillator

The oscillator generates a fixed frequency of 100KHz with frequency jittering of $\pm 4\%$ (which is $\pm 4\text{KHz}$) at a jittering period of 4ms.

A capacitor, a current source and current sink which determine the frequency are integrated. The charging and discharging current of the implemented oscillator capacitor are internally trimmed in order to achieve a very accurate switching frequency. The ratio of controlled charge to discharge current is adjusted to reach a maximum duty cycle limitation of $D_{max}=0.75$.

Once the Soft Start period is over and when the IC goes into normal operating mode, the switching frequency of the clock is varied by the control signal from the Soft Start block. Then the switching frequency is varied in range of $100\text{KHz} \pm 4\text{KHz}$ at period of 4ms.

3.5.2 PWM-Latch FF1

The output of the oscillator block provides continuous pulse to the PWM-Latch which turns on/off the integrated CoolMOS®. After the PWM-Latch is set, it is reset by the PWM comparator, the Soft Start comparator or the Current-Limit comparator. When it is in reset mode, the output of the driver is shut down immediately.

3.5.3 Gate Driver

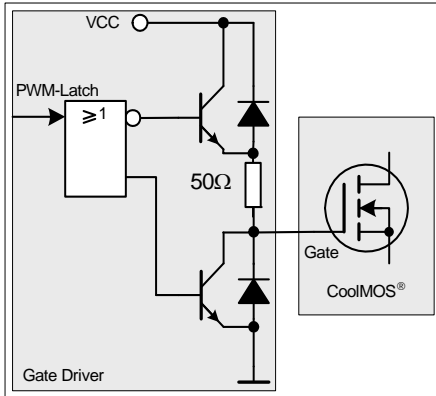

Figure 16 Gate Driver

The driver-stage is optimized to minimize EMI and to provide high circuit efficiency. This is done by reducing the switch on slope when exceeding the integrated CoolMOS® threshold. This is achieved by a slope control of the rising edge at the driver's output (Figure 17) and adding a 50Ω gate turn on resistor (Figure 16). Thus the leading switch on spike is minimized.

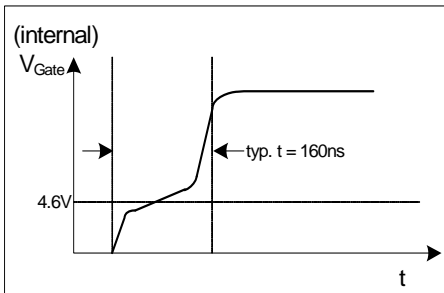

Figure 17 Gate Rising Slope

Furthermore the driver circuit is designed to eliminate cross conduction of the output stage.

During power up, when VCC is below the undervoltage lockout threshold V_{VCCoff} , the output of the Gate Driver is set to low in order to disable power transfer to the secondary side.

3.6 Current Limiting

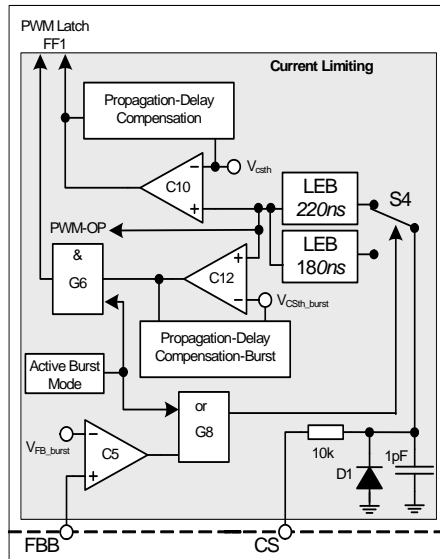

Figure 18 Current Limiting Block

There is a cycle by cycle peak current limiting operation realized by the Current-Limit comparator C10. The source current of the integrated CoolMOS® is sensed via an external sense resistor R_{sense} . By means of R_{sense} the source current is transformed to a sense voltage V_{sense} which is fed into the pin CS. If the voltage V_{sense} exceeds the internal threshold voltage V_{csth} , the comparator C10 immediately turns off the gate drive by resetting the PWM Latch FF1.

A Propagation Delay Compensation is added to support the immediate shut down of the integrated CoolMOS® with very short propagation delay. Thus the influence of the AC input voltage on the maximum output power can be reduced to minimal. This compensation applies to both the peak load and burst mode.

In order to prevent the current limit from distortions caused by leading edge spikes, a Leading Edge Blanking (LEB) is integrated in the current sense path for the comparators C10, C12 and the PWM-OP.

The output of comparator C12 is activated by the Gate G6 if Active Burst Mode is entered. When it is activated, the current limiting is reduced to V_{csth_burst} . This voltage level determines the maximum power level in Active Burst Mode.

3.6.1 Leading Edge Blanking

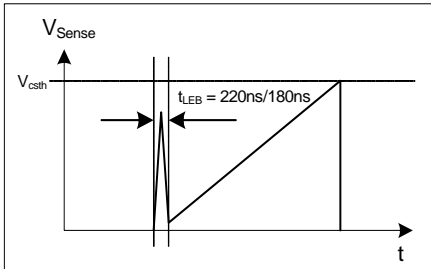

Figure 19 Leading Edge Blanking

Whenever the integrated CoolMOS® is switched on, a leading edge spike is generated due to the primary-side capacitances and reverse recovery time of the secondary-side rectifier. This spike can cause the gate drive to switch off unintentionally. In order to avoid a premature termination of the switching pulse, this spike is blanked out with a time constant of $t_{LEB} = 220\text{ns}$ for normal load and $t_{LEB} = 180\text{ns}$ for burst mode.

3.6.2 Combined OPP curve considering Propagation Delay and Slope Compensation

The ICE3ARxx80CJZ has combined the propagation delay, CCM inherit reduced power effect and the slope compensation effect for the overcurrent control.

It employs the dynamic threshold voltage V_{csth} with 2 steps slope compensation to achieve the closed over current for whole input voltage range.

In case of overcurrent detection, there is always propagation delay to switch off the integrated CoolMOS®. An overshoot of the peak current I_{peak} is induced to the delay, which depends on the ratio of dI/dt of the peak current (Figure 20).

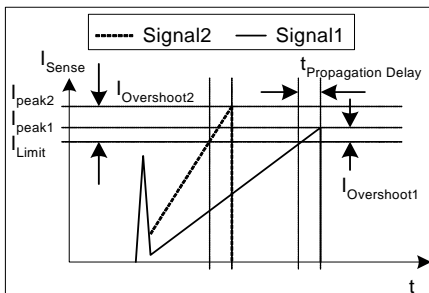

Figure 20 Current Limiting

The overshoot of Signal2 is larger than of Signal1 due to the steeper rising waveform. This change in the

slope is depending on the AC input voltage. Propagation Delay Compensation is integrated to reduce the overshoot due to dI/dt of the rising primary current. Thus the propagation delay time between exceeding the current sense threshold V_{csth} and the switching off of the integrated CoolMOS® is compensated over temperature within a wide input range. Current Limiting is then very accurate.

For the inherit influence of the CCM operation, the final V_{cs} can not be constant in whole line range as in DCM. This ICE3ARxx80CJZ has implemented with 2 compensation curves for the compensation so that the maximum power can be close. One of the curve is used when the time range is larger than $4\mu\text{s}$ and the other is for lower than $4\mu\text{s}$.

The Propagation Delay Compensation is realized by means of a dynamic threshold voltage V_{csth} (Figure 21). In case of a steeper slope the switch off of the driver is earlier to compensate the delay.

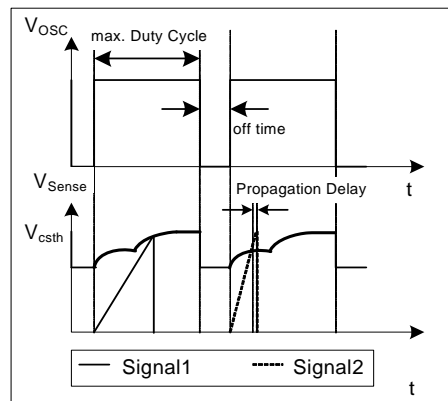

Figure 21 Dynamic Voltage Threshold V_{csth}

A typical measured V_{sense} vs dV_{sense}/dt is plotted in Figure 22 for reference.

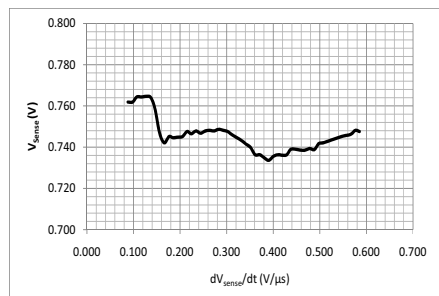

Figure 22 Overcurrent Shutdown

Functional Description

Similarly, the same concept of propagation delay compensation is also implemented in burst mode with reduced level, V_{csth_burst} (Figure 18). With this implementation, the entry and exit burst mode power can be close between low line and high line input voltage.

3.7 Control Unit

The Control Unit contains the functions for Active Burst Mode, Auto Restart Mode and Latch Mode. The Active Burst Mode, Latch Mode and the Auto Restart Mode both have internal blanking time. With the blanking time, the IC avoids entering into those two modes accidentally. Those buffer time is very useful for the application which works in short duration of peak power occasionally.

3.7.1 Active Burst Mode (patented)

To increase the efficiency of the system at light load, the most effective way is to operate at burst mode. Starting from CoolSET® F3, the IC has been employing the active burst mode and it can achieve the lowest standby power. ICE3ARxx80CJZ adopts the same concept with some more innovative improvements to the feature. It includes the adjustable entry burst level, close power control between high line and low line and the smaller output ripple during burst mode.

Most of the burst mode design in the market will provide a fixed entry burst mode level which is a ratio to the maximum power of the design. ICE3ARxx80CJZ provides a more flexible level which can be selected externally.

Propagation delay is the major contributor for the power control variation for DCM flyback converter. It is proved to be effective in the maximum power control. ICE3ARxx80CJZ also apply the same concept in the burst mode. Therefore, the entry and exit burst mode power is also finely controlled during burst mode.

The feedback control swing during burst mode will affect the output ripple voltage directly. ICE3ARxx80CJZ reduces the swing to 0.3V (from 0.5V). Therefore, it would have around 40% improvement for the output ripple.

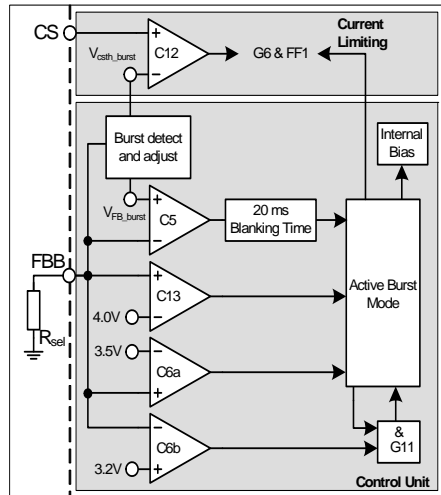

Figure 23 Active Burst Mode

The Active Burst Mode is located in the Control Unit. Figure 23 shows the related components.

3.7.1.1 Selectable burst entry level

The burst mode entry level can be selected by changing the different Resistor R_{sel} at FBB pin. There are 3 levels to be selected with different resistor which are targeted for 15%, 10% and 5% of the maximum input power. At the same time, the exit burst level are targeted to 27%, 20% and 11% of the maximum power accordingly. The below table is the control logic for the entry and exit level with the FBB voltage.

Level	V_{FBB}	R_{sel}
1	$V_{FBB} < V_{ref1}$ (1.8V)	$< 405k\Omega$
2	V_{ref1} (1.8V) $< V_{FBB} < V_{ref2}$ (4.0V)	685k Ω – 900k Ω
3	$V_{FBB} > V_{ref2}$ (4.0V)	$> 1530k\Omega$

Level	Entry level		Exit level	
	% of P_{in_max}	V_{FB_burst}	% of P_{in_max}	V_{csth_burst}
1	5%	1.29V	11%	0.21V
2	10%	1.61V	20%	0.29V
3	15%	1.84V	27%	0.34V

During IC first startup, the Ref_{good} signal is logic low when V_{cc} < 8V. The low Ref_{good} signal will reset the Burst Mode level Detection latch. When the Burst Mode Level Detection latch is low and IC is in OFF state, the FBB resistor is isolated from the FBB pin and a current source I_{sel} (3.5µA) is turned on instead.

From V_{cc}=8V to V_{cc} on threshold (17V), the FBB pin will start to charge to a voltage level associated with R_{sel} resistor. When V_{cc} reaches V_{cc} on threshold, the FBB voltage is sensed. The burst mode thresholds are then chosen according to the FBB voltage level. The Burst Mode Level Detection latch is then set to high. Once the detection latch is set high, any change of the FBB level will not change the threshold level. When V_{cc} reaches V_{cc} on threshold, a timer of 2µs is started. After the 2µs ends, the I_{sel} is turned off while the FBB resistor is connected to FBB pin (Figure 24).

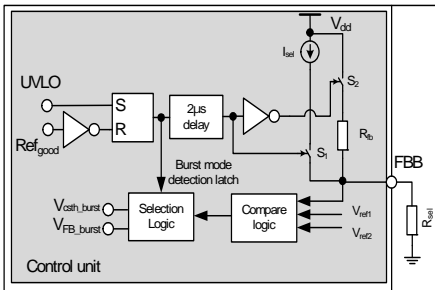

Figure 24 Burst mode detect and adjust

3.7.1.2 Entering Active Burst Mode

The FBB signal is kept monitoring by the comparator C5 (Figure 23). During normal operation, the internal blanking time counter is reset to 0. When FBB signal falls below V_{FB_burst} it starts to count. When the counter reaches 20ms and FBB signal is still below V_{FB_burst}, the system enters the Active Burst Mode. This time window prevents a sudden entering into the Active Burst Mode due to large load jumps.

After entering Active Burst Mode, a burst flag is set and the internal bias is switched off in order to reduce the current consumption of the IC to about 620µA.

It needs the application to enforce the V_{CC} voltage above the Undervoltage Lockout level of 10.5V such that the Startup Cell will not be switched on accidentally. Or otherwise the power loss will increase drastically. The minimum V_{CC} level during Active Burst Mode depends on the load condition and the application. The lowest V_{CC} level is reached at no load condition.

3.7.1.3 Working in Active Burst Mode

After entering the Active Burst Mode, the FBB voltage rises as V_{OUT} starts to decrease, which is due to the inactive PWM section. The comparator C6a monitors the FBB signal. If the voltage level is larger than 3.5V, the internal circuit will be activated; the Internal Bias circuit resumes and starts to provide switching pulse. In Active Burst Mode the gate G6 is released and the current limit is reduced to V_{cth_burst} (Figure 2 and 23). In one hand, it can reduce the conduction loss and the other hand, it can reduce the audible noise. If the load at V_{OUT} is still kept unchanged, the FBB signal will drop to 3.2V. At this level the C6b deactivates the internal circuit again by switching off the Internal Bias. The gate G11 is active again as the burst flag is set after entering Active Burst Mode. In Active Burst Mode, the FBB voltage is changing like a saw tooth between 3.2V and 3.5V (Figure 25).

3.7.1.4 Leaving Active Burst Mode

The FBB voltage will increase immediately if there is a high load jump. This is observed by the comparator C13 (Figure 23). Since the current limit is reduced to 0.21V–0.34V during active burst mode, it needs a certain load jump to rise the FBB signal to exceed 4.0V. At that time the comparator C5 resets the Active Burst Mode control which in turn blocks the comparator C12 by the gate G6. The maximum current can then be resumed to stabilize V_{OUT}.

Functional Description

3.7.2 Protection Modes

The IC provides Auto Restart mode as the major protection feature. Auto Restart mode can prevent the SMPS from destructive states. There are 3 kinds of auto restart mode; normal auto restart mode, odd skip auto restart mode and non switch auto restart mode. Odd skip auto restart mode (Figure 26) is that there is no detect of fault and no switching pulse for the odd number restart cycle. At the even number of restart cycle the fault detect and soft start switching pulses are maintained. However, if the fault is removed, it can release to normal operation only at the even number auto restart cycle.

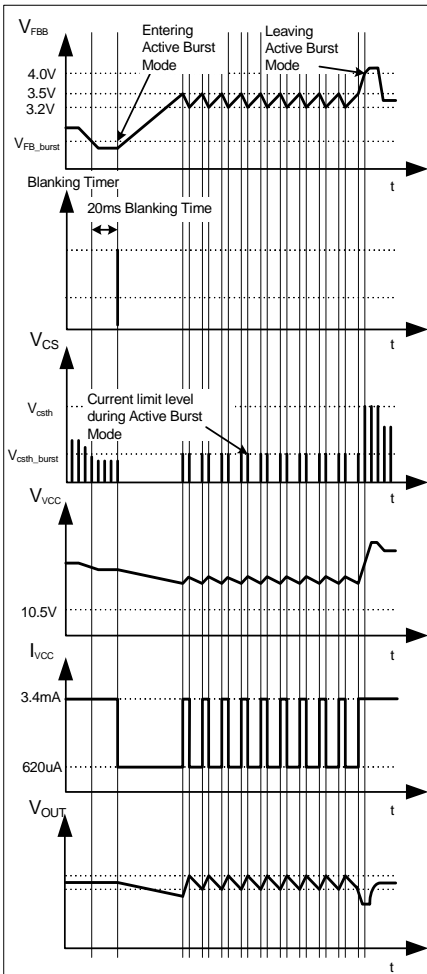

Figure 25 Signals in Active Burst Mode

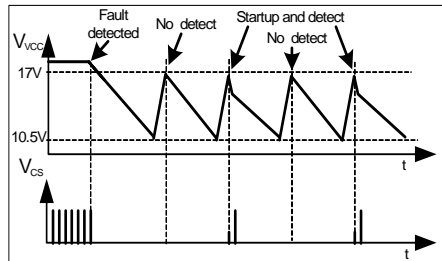

Figure 26 Odd skip auto restart waveform

Non switch auto restart mode is similar to odd skip auto restart mode except the start up switching pulses are also suppressed at the even number of the restart cycle. The detection of fault still remains at the even number of the restart cycle. When the fault is removed, the IC will resume to normal operation at the even number of the restart cycle (Figure 27).

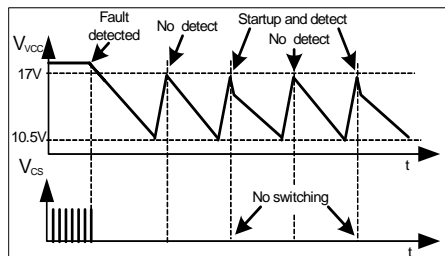

Figure 27 non switch auto restart waveform

The main purpose of the odd skip auto restart is to extend the restart time such that the power loss during auto restart protection can be reduced. This feature is particularly good for smaller Vcc capacitor where the restart time is shorter.

Functional Description

The following table lists the possible system failures and the corresponding protection modes.

VCC Over voltage	Odd skip Auto Restart Mode
Over load	Odd skip Auto Restart Mode
Open Loop	Odd skip Auto Restart Mode
VCC Undervoltage	Normal Auto Restart Mode
Short Optocoupler	Normal Auto Restart Mode
Over temperature	Non switch Auto Restart Mode
External protection enable	Latch Mode

3.7.2.1 Vcc OVP, OTP, external protection enable and Vcc under voltage

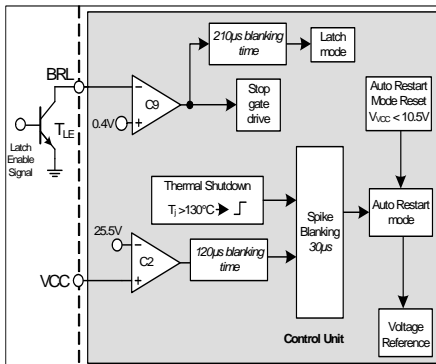

Figure 28 Vcc OVP, OTP, external protection enable

Vcc OVP condition is when V_{VCC} voltage is $> 25.5V$, the IC enters into odd skip Auto Restart Mode (Figure 28). The over temperature protection OTP is sensed inside the controller IC. The Thermal Shutdown block keeps on monitoring the junction temperature of the controller. After detecting a junction temperature higher than $130^{\circ}C$, the IC will enter into the non switch Auto Restart mode. The ICE3ARxx80CJZ has also implemented with a $50^{\circ}C$ hysteresis. That means the IC can only be recovered when the controller junction temperature is dropped $50^{\circ}C$ lower than the over temperature trigger point (Figure 28).

The external latch enable feature can provide a flexibility to a customer's self-defined protection feature. This function can be triggered by pulling down the V_{BRL} voltage to $< 0.4V$. Or it can simply trigger the base pin of an external transistor, T_{LE} at the BRL pin. When this function is enabled, it will enter into latch

mode after $210\mu s$ blanking time. The gate drive is stopped and there is no switching pulse before it is recovered.

The Vcc undervoltage and short opto-coupler will go into the normal auto restart mode inherently.

In case of VCC undervoltage, the Vcc voltage drops indefinitely. When it drops below the Vcc under voltage lock out "OFF" voltage ($10.5V$), the IC will turn off the IC and the startup cell will turn on again. Then the Vcc voltage will be charged up to UVLO "ON" voltage ($17V$) and the IC turns on again provided the startup cell charge up current is not drained by the fault. If the fault is not removed, the Vcc will continue to drop until it hits UVLO "OFF" voltage and the restart cycle repeats.

Short Optocoupler can lead to Vcc undervoltage because once the opto-coupler (transistor side) is shorted, the feedback voltage will drop to zero and there will be no switching pulse. Then the Vcc voltage will drop same as the Vcc undervoltage.

3.7.2.2 Over load, open loop protection

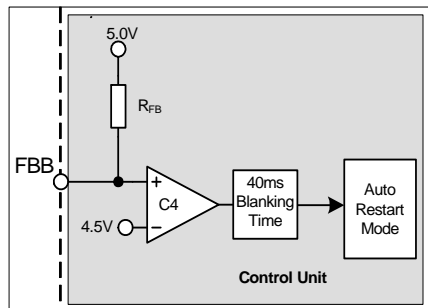

Figure 29 Over load and open loop protection

In case of Overload or Open Loop, the V_{FBB} voltage exceeds $4.5V$ which will be observed by comparator C4. Then the built-in blanking time counter starts to count. When it reaches $40ms$, the odd skip Auto Restart Mode is activated (Figure 29).

3.7.3 Brownout Mode

When the AC input voltage is removed, the voltage at the bulk capacitor will fall. When it reaches a point that the system is greater than the system allowed maximum power, the system may go into over load protection. However, this kind of protection is not expected for some of the applications such as auxiliary power for PC/server system because the output is in hiccup mode due to over load protection (auto restart mode). The brownout mode is to eliminate this phenomenon. The ICE3ARxx80CJZ will sense the

Functional Description

input AC voltage to the BRL pin by an AC hold up circuit and 2 potential divider resistors.

In some applications, it needs the IC to continue to work for certain time when AC voltage is disconnected. After that, the IC will stop working. If the brownout connection is tapping from the bulk capacitor, the delay time is too short. Therefore, it needs the brown out detection at the AC input (Figure 30). The C_{BR0} is charged up by AC line voltage through R_{BR0} , which is then fed to BRL pin through a voltage divider. When the AC voltage drops, if the BRL voltage is lower than 1V for $270\mu s$, the ICE3ARxx80CJZ will go into brownout mode. If, however, the AC line goes up again, the BRL voltage will be larger than 1.25V and the ICE3ARxx80CJZ will leave brown out mode and recover to normal operation.

The brownout mode is default "ON" during the system starts up. When the system is powered up, the bulk capacitor and the Vcc capacitor are charged up at the same time. When the Vcc voltage is charged to $>8V$, the brownout circuit starts to operate (Figure 30). Since the UVLO is still at low level as the Vcc voltage does not reach the 17V UVLO "ON" voltage. The NAND gate G20 will release a low signal to the flip flop FF2 and the negative output of FF2 will release a high signal. Hence it is in brownout mode during the system starts up.

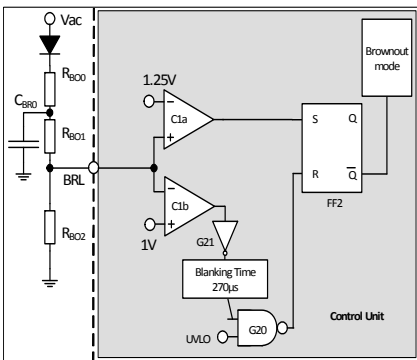

Figure 30 Brownout detection circuit

Once the system enters the brownout mode, there will be no switching pulse and the IC enters into another type auto-restart mode which is similar to the protection auto-restart mode but the IC will monitor the BRL signal in each restart cycle (Figure 31).

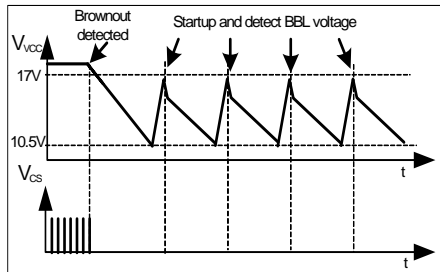

Figure 31 Brownout mode waveform

If the brownout feature is not needed, it needs to tie the BRL pin to the Vcc pin through a current limiting resistor, $5M\Omega\sim 10M\Omega$. The BRL pin cannot be in floating condition.

3.7.4 Fast AC reset

During normal operation, the ICE3ARxx80CJZ can be latched by pulling down the BRL voltage below 0.4V for $210\mu s$. There are 2 conditions to reset the latch feature. The first one is to pull down the Vcc voltage to below 8V. However, the Vcc drop would take quite a long time if it is by normal AC power down. The second one is to have a slow rise time of the BRL voltage from 0.4V to 1V for at least $450\mu s$ after the BRL pin is pulled down. This timing can be achieved by the AC recycle. And it is also called the fast AC reset (Figure 32).

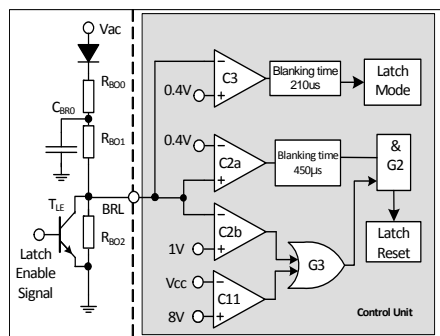

Figure 32 Latch and fast AC reset

Figure 33 shows different latch and reset cases.

Case a : not latched (solid line); the timing below 0.4V is $150\mu s$ and is less than $210\mu s$.

Functional Description

Case b : latched (dashed line); the timing below 0.4V is 450 μ s which is larger than 210 μ s. No latch reset as the rise time from 0.4V to 1V is 300 μ s which is less than the 450 μ s.

Case c : latched and reset (dotted line); the timing below 0.4V is 710 μ s which is larger than 210 μ s. But the rise time from 0.4V to 1V is 560 μ s which is larger than the latch reset blanking time of 450 μ s.

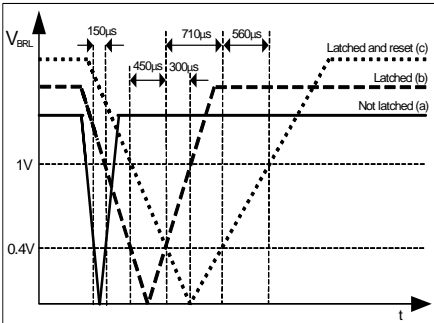

Figure 33 Latch and fast AC reset example

4 Electrical Characteristics

Note: All voltages are measured with respect to ground (Pin 8). The voltage levels are valid if other ratings are not violated.

4.1 Absolute Maximum Ratings

Note: Absolute maximum ratings are defined as ratings, which when being exceeded may lead to destruction of the integrated circuit. For the same reason make sure, that any capacitor that will be connected to pin 7 (VCC) is discharged before assembling the application circuit. $T_a=25^{\circ}\text{C}$ unless otherwise specified.

Parameter	Symbol	Limit Values		Unit	Remarks
		min.	max.		
Drain Source Voltage	V_{DS}	-	800	V	
Pulse drain current, t_p limited by T_{Jmax}	I_{D_Puls}	-	1.95	A	
Avalanche energy, repetitive t_{AR} limited by max. $T_j=150^{\circ}\text{C}$ ¹⁾	E_{AR}	-	0.024	mJ	
Avalanche current, repetitive t_{AR} limited by max. $T_j=150^{\circ}\text{C}$	I_{AR}	-	0.95	A	
VCC Supply Voltage	V_{VCC}	-0.3	27	V	
FBB Voltage	V_{FBB}	-0.3	5.5	V	
BRL Voltage	V_{BRL}	-0.3	5.5	V	
CS Voltage	V_{CS}	-0.3	5.5	V	
Junction Temperature	T_j	-40	150	°C	Controller & CoolMOS®
Storage Temperature	T_s	-55	150	°C	
Thermal Resistance Junction -Ambient	R_{thJA}	-	96	K/W	
Soldering temperature, wavesoldering only allowed at leads	T_{sold}	-	260	°C	1.6mm (0.063in.) from case for 10s
ESD Capability (incl. Drain Pin)	V_{ESD}	-	2	kV	Human body model ²⁾

¹⁾ Repetitive avalanche causes additional power losses that can be calculated as $P_{AV}=E_{AR} \cdot f$

²⁾ According to EIA/JESD22-A114-B (discharging a 100pF capacitor through a 1.5kΩ series resistor)

4.2 Operating Range

Note: Within the operating range the IC operates as described in the functional description.

Parameter	Symbol	Limit Values		Unit	Remarks
		min.	max.		
VCC Supply Voltage	V_{VCC}	V_{VCCoff}	24.7	V	Max value limited due to Vcc OVP
Junction Temperature of Controller	T_{Jcon}	-25	130	°C	Max value limited due to thermal shut down of controller
Junction Temperature of CoolMOS®	$T_{JcoolMOS}$	-25	150	°C	

4.3 Characteristics

4.3.1 Supply Section

Note: The electrical characteristics involve the spread of values within the specified supply voltage and junction temperature range T_J from -25 °C to 125 °C . Typical values represent the median values, which are related to 25 °C . If not otherwise stated, a supply voltage of $V_{CC} = 17\text{ V}$ is assumed.

Parameter	Symbol	Limit Values			Unit	Test Condition
		min.	typ.	max.		
Start Up Current	$I_{VCCstart}$	-	210	300	μA	$V_{VCC} = 16\text{ V}$
VCC Charge Current	$I_{VCCcharge1}$	-	-	5.0	mA	$V_{VCC} = 0\text{ V}$
	$I_{VCCcharge2}$	0.55	1.0	1.60	mA	$V_{VCC} = 1\text{ V}$
	$I_{VCCcharge3}$	0.38	0.75	-	mA	$V_{VCC} = 16\text{ V}$
Leakage Current of Start Up Cell and CoolMOS®	$I_{StartLeak}$	-	0.2	50	μA	$V_{Drain} = 650\text{ V}$ at $T_J = 100\text{ °C}$ ¹⁾
Supply Current with Inactive Gate	$I_{VCCsup1}$	-	1.9	3.2	mA	
Supply Current with Active Gate	$I_{VCCsup2}$	-	3.4	4.8	mA	$I_{FBB} = 0\text{ A}$
Supply Current in Latched Off Mode with Inactive Gate	$I_{VCClatch}$	-	420	-	μA	$I_{FBB} = 0\text{ A}$
Supply Current in Auto Restart Mode with Inactive Gate	$I_{VCCrestart}$	-	420	-	μA	$I_{FBB} = 0\text{ A}$
Supply Current in Active Burst Mode with Inactive Gate	$I_{VCCburst1}$	-	620	950	μA	$V_{FBB} = 2.5\text{ V}$
	$I_{VCCburst2}$	-	620	950	μA	$V_{VCC} = 11.5\text{ V}$, $V_{FBB} = 2.5\text{ V}$
VCC Turn-On Threshold	V_{VCCon}	16.0	17.0	18.0	V	
VCC Turn-Off Threshold	V_{VCCoff}	9.8	10.5	11.2	V	
VCC Turn-On/Off Hysteresis	$V_{VCCchys}$	-	6.5	-	V	

¹⁾ The parameter is not subjected to production test - verified by design/characterization

Electrical Characteristics
4.3.2 Internal Voltage Reference

Parameter	Symbol	Limit Values			Unit	Test Condition
		min.	typ.	max.		
Trimmed Reference Voltage	V_{REF}	4.90	5.00	5.10	V	measured at pin FBB $I_{FBB} = 0A$

4.3.3 PWM Section

Parameter	Symbol	Limit Values			Unit	Test Condition
		min.	typ.	max.		
Fixed Oscillator Frequency	f_{OSC1}	87	100	113	kHz	
	f_{OSC2}	92	100	108		
Frequency Jittering Range	f_{jitter}	-	± 4.0	-	kHz	$T_j = 25^\circ C$
Frequency Jittering period	T_{jitter}	-	4.0	-	ms	$T_j = 25^\circ C$
Max. Duty Cycle	D_{max}	0.70	0.75	0.80		
Min. Duty Cycle	D_{min}	-	-	0		$V_{FBB} < 0.3V$
PWM-OP Gain	A_v	3.17	3.25	3.33		
Voltage Ramp Offset	$V_{Offset-Ramp}$	-	0.60	-	V	
V_{FBB} Operating Range Min Level	V_{FBmin}	-	0.7	-	V	
V_{FBB} Operating Range Max level	V_{FBmax}	-	-	4.4	V	$dV_{sense}/dt = 0.134V/\mu s$, limited by Comparator C4 ¹⁾
FBB Pull-Up Resistor	R_{FB}	9.0	15.4	22.0	k Ω	
Slope Compensation rate	M_C	45	50	55	mV/ μs	CS=0V

¹⁾ The parameter is not subjected to production test - verified by design/characterization

4.3.4 Soft Start time

Parameter	Symbol	Limit Values			Unit	Test Condition
		min.	typ.	max.		
Soft Start time	t_{SS}	-	10	-	ms	

Electrical Characteristics
4.3.5 Control Unit

Parameter	Symbol	Limit Values			Unit	Test Condition	
		min.	typ.	max.			
Brownout reference voltage for comparator C1a	V_{BO_L}	1.14	1.25	1.36	V		
Brownout reference voltage for comparator C1b	V_{BO_E}	0.91	1	1.09	V		
Leakage current of BRL pin	$I_{leakage}$	-0.5	-	0.5	μ A		
Blanking time to enter brownout mode	V_{BKC1b}	190	270	310	μ s		
Fast AC reset voltage for comparator C2a	V_{C2a}	0.3	0.4	0.5	V		
Fast AC reset voltage for comparator C2b	V_{C2b}	0.91	1	1.09	V		
Blanking time for comparator C2a	V_{BKC2a}	315	450	585	μ s		
Charging current to select burst mode	I_{sel}	2.8	3.5	4.2	μ A		
Burst mode selection reference voltage	V_{ref1}	1.69	1.80	1.91	V		
	V_{ref2}	3.78	4.00	4.22	V		
Over Load Limit for Comparator C4	V_{FBC4}	4.40	4.50	4.72	V		
Active Burst Mode Entry level for Comparator C5	15% P_{in_max}	V_{FB_burst1}	1.77	1.84	1.91	V	$V_{fbb} > V_{ref2}$
	10% P_{in_max}	V_{FB_burst2}	1.50	1.61	1.72	V	$V_{ref1} < V_{fbb} < V_{ref2}$
	5% P_{in_max}	V_{FB_burst3}	1.20	1.29	1.38	V	$V_{fbb} < V_{ref1}$
Active Burst Mode High Level for Comparator C6a	V_{FBC6a}	3.35	3.50	3.65	V	In Active Burst Mode	
Active Burst Mode Low Level for Comparator C6b	V_{FBC6b}	3.06	3.20	3.34	V		
Active Burst Mode Level for Comparator C9	V_{FBC9}	3.85	4.00	4.15	V		
Overvoltage Detection Limit for Comparator C2	V_{VCCOVP}	24.7	25.5	26.3	V		
Latch enable reference voltage for Comparator C3	V_{LE}	0.3	0.4	0.5	V		
Built-in Blanking Time to enter Latch Mode	t_{BK_latch}	140	210	295	μ s		
Thermal Shutdown ¹⁾	T_{JSD}	130	140	150	$^{\circ}$ C	Controller	
Hysteresis for thermal Shutdown ¹⁾	T_{JSD_hys}	-	50	-	$^{\circ}$ C		
Built-in Blanking Time for Overload Protection	t_{BK}	-	40	-	ms		
Built-in Blanking Time for entering Active Burst Mode	t_{BK_burst}	-	20	-	ms		
Spike Blanking Time for Vcc OVP	t_{Spike}	-	150	-	μ s		

Electrical Characteristics

¹⁾ The parameter is not subjected to production test - verified by design/characterization. The thermal shutdown temperature refers to the junction temperature of the controller.

Note: The trend of all the voltage levels in the Control Unit is the same regarding the deviation except V_{VCCOVP} .

4.3.6 Current Limiting

Parameter	Symbol	Limit Values			Unit	Test Condition	
		min.	typ.	max.			
Peak Current Limitation	V_{csth1}	0.69	0.73	0.77	V	$dV_{sense} / dt = 0.41V/\mu s$	
	V_{csth2}	0.72	0.76	0.80	V	$dV_{sense} / dt = 0.134V/\mu s$	
Peak Current Limitation in Active Burst Mode	27% P_{in_max}	V_{csth_burst1}	0.313	0.34	0.368	V	$V_{fbb} > V_{ref2}$
	20% P_{in_max}	V_{csth_burst2}	0.264	0.29	0.320	V	$V_{ref1} < V_{fbb} < V_{ref2}$
	11% P_{in_max}	V_{csth_burst3}	0.184	0.21	0.238	V	$V_{fbb} < V_{ref1}$
Leading Edge Blanking	Normal mode	t_{LEB_normal}	-	220	-	ns	
	Burst mode	t_{LEB_burst}	-	180	-	ns	
CS Input Bias Current	I_{CSbias}	-1.5	-0.2	-	μA	$V_{CS} = 0V$	

4.3.7 CoolMOS® Section

Parameter	Symbol	Limit Values			Unit	Test Condition
		min.	typ.	max.		
Drain Source Breakdown Voltage	$V_{(BR)DSS}$	800	-	-	V	$T_j = 25^\circ C$
		870	-	-	V	$T_j = 110^\circ C^1)$
Drain Source On-Resistance	R_{DSon}	-	4.70	5.18	Ω	$T_j = 25^\circ C$
		-	10.45	11.50	Ω	$T_j = 125^\circ C^1)$
		-	12.76	14.04	Ω	$T_j = 150^\circ C^1)$ at $I_D = 0.58A$
Effective output capacitance, energy related	$C_{o(er)}$	-	7.2	-	pF	$V_{DS} = 0V$ to 480V
Rise Time	t_{rise}	-	30 ²⁾	-	ns	
Fall Time	t_{fall}	-	30 ²⁾	-	ns	

¹⁾ The parameter is not subjected to production test - verified by design/characterization

²⁾ Measured in a Typical Flyback Converter Application

5 CoolMOS® Performance Characteristic

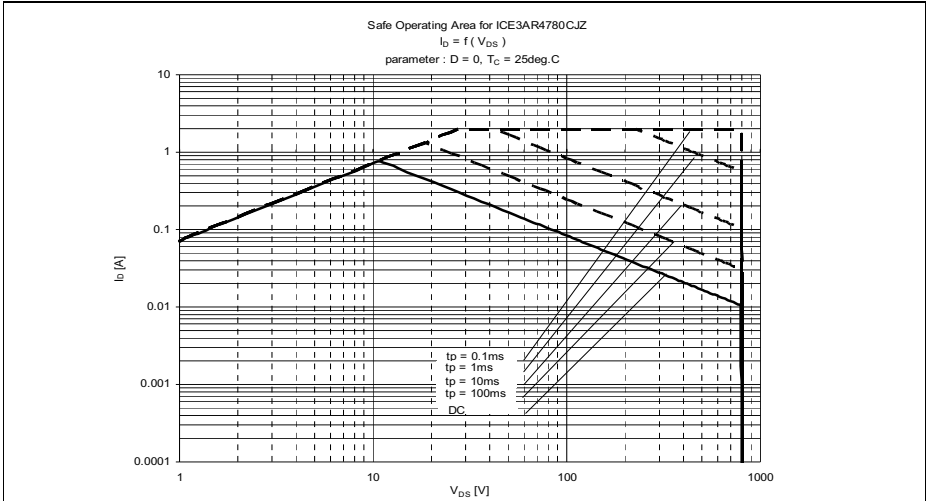

Figure 34 Safe Operating Area (SOA) curve for ICE3AR4780CJZ

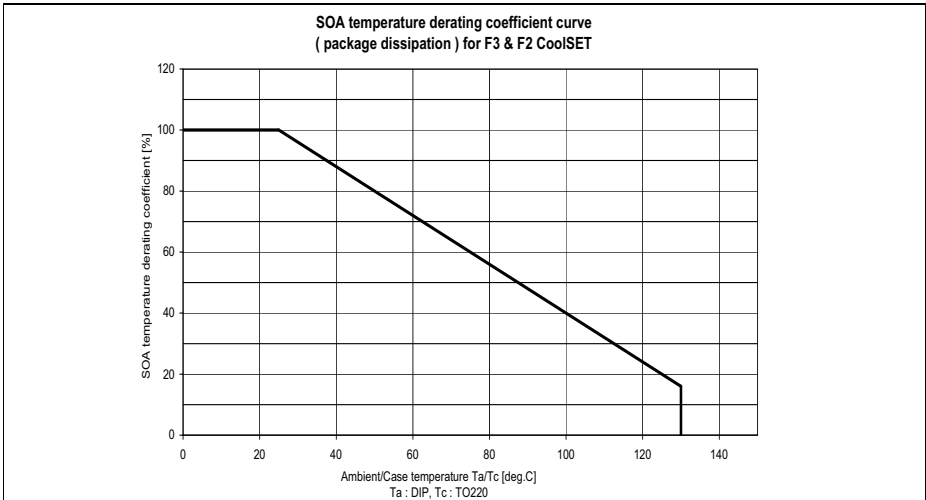

Figure 35 SOA temperature derating coefficient curve

CoolMOS® Performance Characteristic

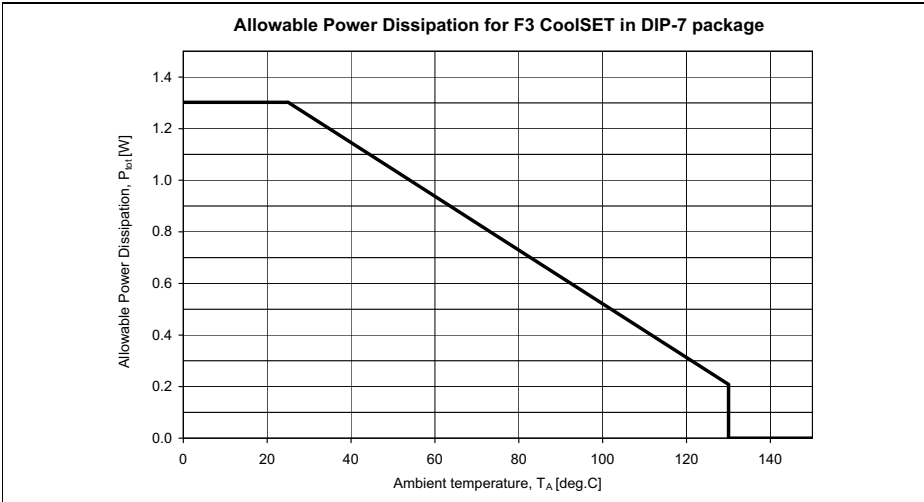

Figure 36 Power dissipation; $P_{tot}=f(T_a)$

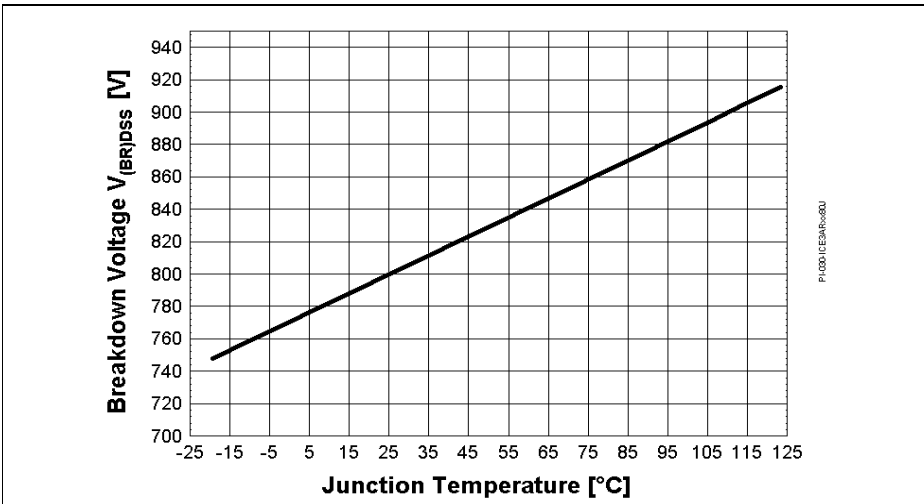

Figure 37 Drain-source breakdown voltage; $V_{BR(DSS)}=f(T_j)$, $I_D=0.25mA$

6 Input Power Curve

Two input power curves giving the typical input power versus ambient temperature are shown below; $V_{in}=85\text{Vac}\text{--}265\text{Vac}$ (Figure 38) and $V_{in}=230\text{Vac}\pm 15\%$ (Figure 39). The curves are derived based on a typical discontinuous mode flyback model which considers either 60% maximum duty ratio or 150V maximum secondary to primary reflected voltage (higher priority). The calculation is based on no copper area as heatsink for the device. The input power already includes the power loss at input common mode choke, bridge rectifier and the CoolMOS. The device saturation current (I_{D_Puls} @ $T_j=125^\circ\text{C}$) is also considered.

To estimate the output power of the device, it is simply multiplying the input power at a particular operating ambient temperature with the estimated efficiency for the application. For example, a wide range input voltage (Figure 38), operating temperature is 50°C , estimated efficiency is 85%, then the estimated output power is 17W ($20\text{W} * 85\%$).

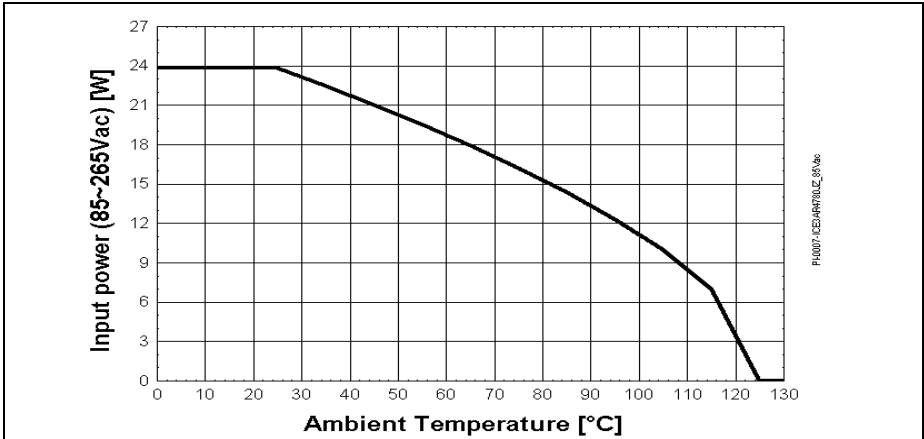

Figure 38 Input power curve $V_{in}=85\text{--}265\text{Vac}$; $P_{in}=f(T_a)$

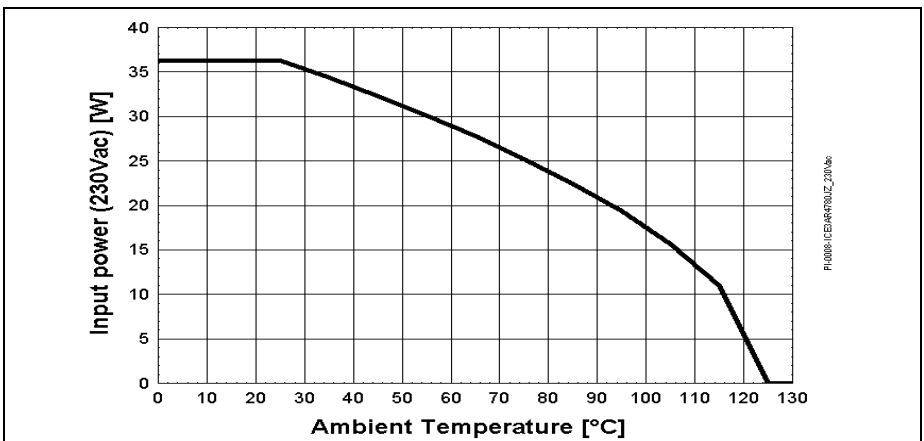
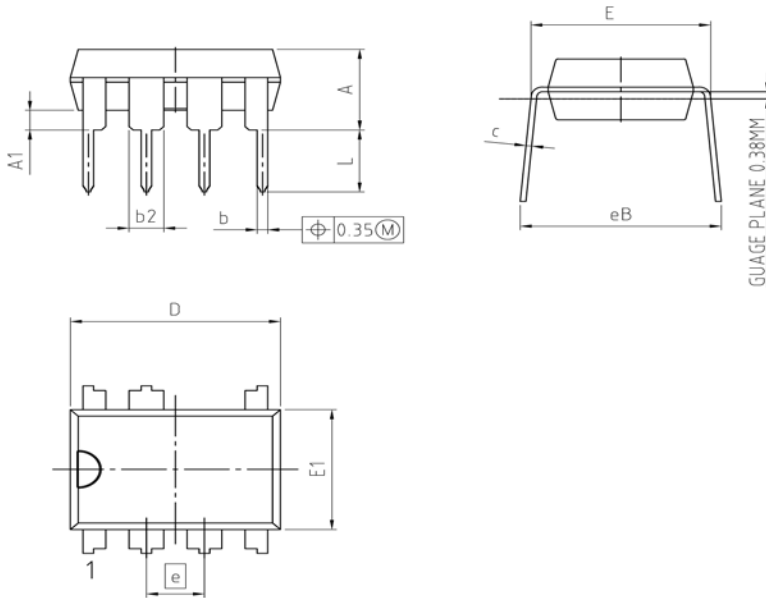

Figure 39 Input power curve $V_{in}=230\text{Vac}\pm 15\%$; $P_{in}=f(T_a)$

7 Outline Dimension

PG-DIP-7 (Plastic Dual In-Line Outline)



1) DOES NOT INCLUDE MOLD FLASH OR PROTRUSIONS.

DIM	MILLIMETERS		INCHES	
	MIN	MAX	MIN	MAX
A	-	4.57	-	0.180
A1	0.38	-	0.015	-
b	0.36	0.56	0.014	0.022
b2	-	1.70	-	0.067
c	0.20	0.36	0.008	0.014
D	9.10	9.77	0.358	0.385
E	7.49	8.26	0.295	0.325
E1	8.10	8.60	0.240	0.260
e	2.54 BSC		0.1 BSC	
N	7		7	
eB	7.90	10.90	0.311	0.429
L	2.92	-	0.115	-

DOCUMENT NO.
Z8B00155542

SCALE

EUROPEAN PROJECTION

ISSUE DATE
22.07.2011

REVISION
02

Figure 40 PG-DIP-7 (Pb-free lead plating Plastic Dual-in-Line Outline)

8 Marking

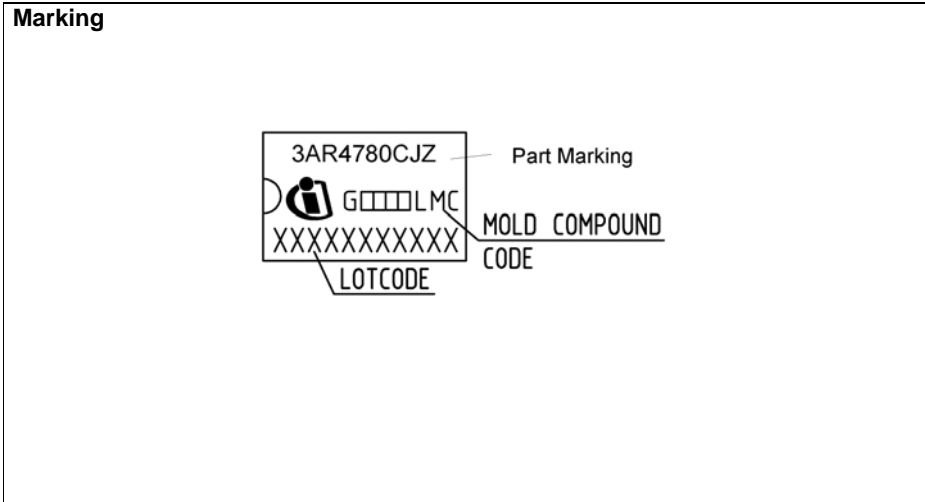

Figure 41 Marking for ICE3AR4780CJZ

Schematic for recommended PCB layout

9 Schematic for recommended PCB layout

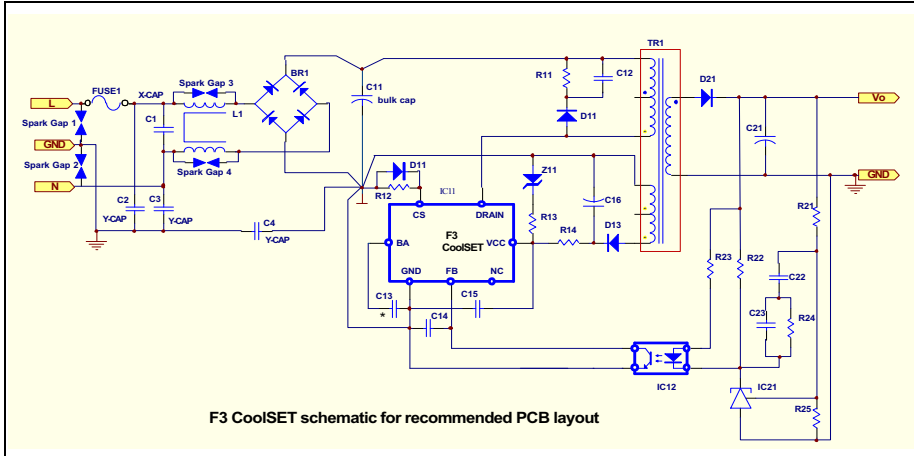

Figure 42 Schematic for recommended PCB layout

General guideline for PCB layout design using F3 CoolSET (refer to Figure 42):

1. “Star Ground “at bulk capacitor ground, C11:

“Star Ground “means all primary DC grounds should be connected to the ground of bulk capacitor C11 separately in one point. It can reduce the switching noise going into the sensitive pins of the CoolSET device effectively. The primary DC grounds include the followings.

- a. DC ground of the primary auxiliary winding in power transformer, TR1, and ground of C16 and Z11.
- b. DC ground of the current sense resistor, R12
- c. DC ground of the CoolSET device, GND pin of IC11; the signal grounds from C13, C14, C15 and collector of IC12 should be connected to the GND pin of IC11 and then “star “connect to the bulk capacitor ground.
- d. DC ground from bridge rectifier, BR1
- e. DC ground from the bridging Y-capacitor, C4

2. High voltage traces clearance:

High voltage traces should keep enough spacing to the nearby traces. Otherwise, arcing would incur.

- a. 400V traces (positive rail of bulk capacitor C11) to nearby trace: > 2.0mm
- b. 600V traces (drain voltage of CoolSET IC11) to nearby trace: > 2.5mm

3. Filter capacitor close to the controller ground:

Filter capacitors, C13, C14 and C15 should be placed as close to the controller ground and the controller pin as possible so as to reduce the switching noise coupled into the controller.

Guideline for PCB layout design when >3KV lightning surge test applied (refer to Figure 42):

1. Add spark gap

Spark gap is a pair of saw-tooth like copper plate facing each other which can discharge the accumulated charge during surge test through the sharp point of the saw-tooth plate.

- a. Spark Gap 3 and Spark Gap 4, input common mode choke, L1:
Gap separation is around 1.5mm (no safety concern)

Schematic for recommended PCB layout

b. Spark Gap 1 and Spark Gap 2, Live / Neutral to GROUND:

These 2 Spark Gaps can be used when the lightning surge requirement is >6KV.

230Vac input voltage application, the gap separation is around 5.5mm

115Vac input voltage application, the gap separation is around 3mm

2. Add Y-capacitor (C2 and C3) in the Live and Neutral to ground even though it is a 2-pin input

3. Add negative pulse clamping diode, D11 to the Current sense resistor, R12:

The negative pulse clamping diode can reduce the negative pulse going into the CS pin of the CoolSET and reduce the abnormal behavior of the CoolSET. The diode can be a fast speed diode such as IN4148.

The principle behind is to drain the high surge voltage from Live/Neutral to Ground without passing through the sensitive components such as the primary controller, IC11.

Total Quality Management

Qualität hat für uns eine umfassende Bedeutung. Wir wollen allen Ihren Ansprüchen in der bestmöglichen Weise gerecht werden. Es geht uns also nicht nur um die Produktqualität – unsere Anstrengungen gelten gleichermaßen der Lieferqualität und Logistik, dem Service und Support sowie allen sonstigen Beratungs- und Betreuungsleistungen.

Dazu gehört eine bestimmte Geisteshaltung unserer Mitarbeiter. Total Quality im Denken und Handeln gegenüber Kollegen, Lieferanten und Ihnen, unserem Kunden. Unsere Leitlinie ist jede Aufgabe mit „Null Fehlern“ zu lösen – in offener Sichtweise auch über den eigenen Arbeitsplatz hinaus – und uns ständig zu verbessern.

Unternehmensweit orientieren wir uns dabei auch an „top“ (Time Optimized Processes), um Ihnen durch größere Schnelligkeit den entscheidenden Wettbewerbsvorsprung zu verschaffen.

Geben Sie uns die Chance, hohe Leistung durch umfassende Qualität zu beweisen.

Wir werden Sie überzeugen.

Quality takes on an allencompassing significance at Semiconductor Group. For us it means living up to each and every one of your demands in the best possible way. So we are not only concerned with product quality. We direct our efforts equally at quality of supply and logistics, service and support, as well as all the other ways in which we advise and attend to you.

Part of this is the very special attitude of our staff. Total Quality in thought and deed, towards co-workers, suppliers and you, our customer. Our guideline is “do everything with zero defects”, in an open manner that is demonstrated beyond your immediate workplace, and to constantly improve.

Throughout the corporation we also think in terms of Time Optimized Processes (top), greater speed on our part to give you that decisive competitive edge.

Give us the chance to prove the best of performance through the best of quality – you will be convinced.

<http://www.infineon.com>

X-ON Electronics

Largest Supplier of Electrical and Electronic Components

Click to view similar products for [AC/DC Converters](#) category:

Click to view products by [Infineon](#) manufacturer:

Other Similar products are found below :

[FSFR2100US](#) [BP5722A12](#) [ICE3AR0680VJZ](#) [ICE3AR2280CJZ](#) [ICE3BR0680JZ](#) [ICE3BR2280JZ](#) [SEA01](#) [FAN7621SSJX](#) [BP5055-12](#)
[BP5718A12](#) [ICE2QR4780Z](#) [NCP1124BP100G](#) [AP3983EP7-G1](#) [ICE3AR10080CJZ](#) [SC1076P065G](#) [47132](#) [47220](#) [47225](#) [APR3415BMTR-](#)
[G1](#) [NCP1126BP100G](#) [HF500GP-40](#) [TNY179PN](#) [ICE3AR10080JZXKLA1](#) [BM2P0361-Z](#) [BM2P249Q-Z](#) [BM521Q25F-GE2](#) [INN3164C-](#)
[H107-TL](#) [HR1001CGS-P](#) [HR1001LGS-P](#) [BM2P131X-Z](#) [BM2P161X-Z](#) [BM2P181X-Z](#) [BM2P201X-Z](#) [BM2P241X-Z](#) [LNK576DG-TL](#)
[INN3278C-H215-TL](#) [INN3278C-H217-TL](#) [INN3678C-H605-TL](#) [TNY263PN](#) [TNY286PG](#) [TNY287PG](#) [TNY288DG-TL](#) [TNY288PG](#)
[BP5034D24](#) [ICE2QR2280Z1XKLA1](#) [ICE2QS02GXUMA1](#) [ICE3A1065ELJFKLA1](#) [ICE3AR2280JZXKLA1](#) [ICE3B1565JFKLA1](#) [INN2003K](#)