

EVAL-M1-IM241 user guide

iMOTION™ modular application design kit

About this document

Scope and purpose

This user guide provides an overview of the evaluation board EVAL-M1-IM241 including its main features, key data, pin assignments and mechanical dimensions.

The EVAL-M1-IM241 is an evaluation board for motor drive applications, as part of the iMOTION™ modular application design kit. In combination with the control board equipped with the M1 20-pin interface connector such as EVAL-M1-101T, it features and demonstrates Infineon's CIPOS™ Micro IPM technology and advanced motion control engine (MCE 2.0) technology for permanent magnet motors drive.

The IM241-L6T2B CIPOS™ Micro IPM has 600 V of voltage and 6 A of current rating. It is optimized for small home appliances like pumps, fans and other low power motor drive applications.

This evaluation board EVAL-M1-IM241 is developed to support customers during their first steps designing applications with CIPOS™ Micro IPM IM241-L6T2B and running any permanent magnet motor via sensorless sinusoidal control.

Intended audience

This user guide is intended for all technical specialists who know motor control, low-power electronics converters. The board is intended to be used under laboratory conditions.

Evaluation Board

This board will be used during design in, for evaluation and measurement of characteristics, and proof of data sheet specifications.

Note: PCB and auxiliary circuits are not optimized for final customer design.

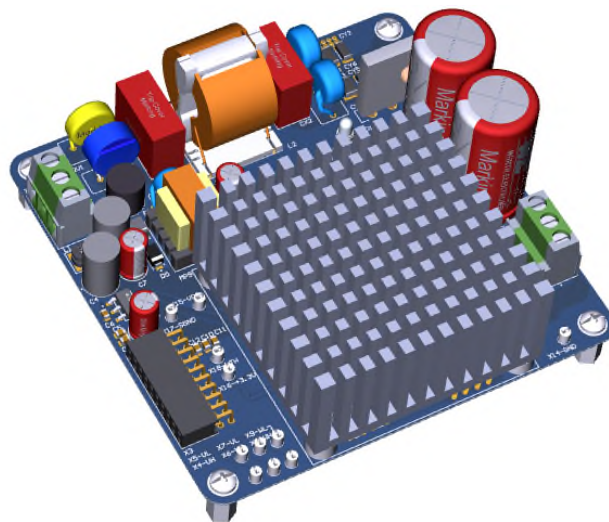

Important notice

Important notice

“Evaluation Boards and Reference Boards” shall mean products embedded on a printed circuit board (PCB) for demonstration and/or evaluation purposes, which include, without limitation, demonstration, reference and evaluation boards, kits and design (collectively referred to as “Reference Board”).

Environmental conditions have been considered in the design of the Evaluation Boards and Reference Boards provided by Infineon Technologies. The design of the Evaluation Boards and Reference Boards has been tested by Infineon Technologies only as described in this document. The design is not qualified in terms of safety requirements, manufacturing and operation over the entire operating temperature range or lifetime.

The Evaluation Boards and Reference Boards provided by Infineon Technologies are subject to functional testing only under typical load conditions. Evaluation Boards and Reference Boards are not subject to the same procedures as regular products regarding returned material analysis (RMA), process change notification (PCN) and product discontinuation (PD).

Evaluation Boards and Reference Boards are not commercialized products, and are solely intended for evaluation and testing purposes. In particular, they shall not be used for reliability testing or production. The Evaluation Boards and Reference Boards may therefore not comply with CE or similar standards (including but not limited to the EMC Directive 2004/EC/108 and the EMC Act) and may not fulfill other requirements of the country in which they are operated by the customer. The customer shall ensure that all Evaluation Boards and Reference Boards will be handled in a way which is compliant with the relevant requirements and standards of the country in which they are operated.

The Evaluation Boards and Reference Boards as well as the information provided in this document are addressed only to qualified and skilled technical staff, for laboratory usage, and shall be used and managed according to the terms and conditions set forth in this document and in other related documentation supplied with the respective Evaluation Board or Reference Board.

It is the responsibility of the customer’s technical departments to evaluate the suitability of the Evaluation Boards and Reference Boards for the intended application, and to evaluate the completeness and correctness of the information provided in this document with respect to such application.

The customer is obliged to ensure that the use of the Evaluation Boards and Reference Boards does not cause any harm to persons or third party property.

The Evaluation Boards and Reference Boards and any information in this document is provided "as is" and Infineon Technologies disclaims any warranties, express or implied, including but not limited to warranties of non-infringement of third party rights and implied warranties of fitness for any purpose, or for merchantability.

Infineon Technologies shall not be responsible for any damages resulting from the use of the Evaluation Boards and Reference Boards and/or from any information provided in this document. The customer is obliged to defend, indemnify and hold Infineon Technologies harmless from and against any claims or damages arising out of or resulting from any use thereof.

Infineon Technologies reserves the right to modify this document and/or any information provided herein at any time without further notice.

Safety precautions

Safety precautions

Note: Please note the following warnings regarding the hazards associated with development systems.

Table 1 Safety precautions

	<p>Warning: The DC link potential of this board is up to 400 VDC. When measuring voltage waveforms by oscilloscope, high voltage differential probes must be used. Failure to do so may result in personal injury or death.</p>
	<p>Warning: The evaluation or reference board contains DC bus capacitors which take time to discharge after removal of the main supply. Before working on the drive system, wait five minutes for capacitors to discharge to safe voltage levels. Failure to do so may result in personal injury or death. Darkened display LEDs are not an indication that capacitors have discharged to safe voltage levels.</p>
	<p>Warning: The evaluation or reference board is connected to the grid input during testing. Hence, high-voltage differential probes must be used when measuring voltage waveforms by oscilloscope. Failure to do so may result in personal injury or death. Darkened display LEDs are not an indication that capacitors have discharged to safe voltage levels.</p>
	<p>Warning: Remove or disconnect power from the drive before you disconnect or reconnect wires, or perform maintenance work. Wait five minutes after removing power to discharge the bus capacitors. Do not attempt to service the drive until the bus capacitors have discharged to zero. Failure to do so may result in personal injury or death.</p>
	<p>Caution: The heat sink and device surfaces of the evaluation or reference board may become hot during testing. Hence, necessary precautions are required while handling the board. Failure to comply may cause injury.</p>
	<p>Caution: Only personnel familiar with the drive, power electronics and associated machinery should plan, install, commission and subsequently service the system. Failure to comply may result in personal injury and/or equipment damage.</p>
	<p>Caution: The evaluation or reference board contains parts and assemblies sensitive to electrostatic discharge (ESD). Electrostatic control precautions are required when installing, testing, servicing or repairing the assembly. Component damage may result if ESD control procedures are not followed. If you are not familiar with electrostatic control procedures, refer to the applicable ESD protection handbooks and guidelines.</p>
	<p>Caution: A drive that is incorrectly applied or installed can lead to component damage or reduction in product lifetime. Wiring or application errors such as undersizing the motor, supplying an incorrect or inadequate AC supply, or excessive ambient temperatures may result in system malfunction.</p>
	<p>Caution: The evaluation or reference board is shipped with packing materials that need to be removed prior to installation. Failure to remove all packing materials that are unnecessary for system installation may result in overheating or abnormal operating conditions.</p>

Table of contents

About this document.....	1
Important notice	2
Safety precautions.....	3
Table of contents	4
1 The board at a glance.....	5
1.1 Delivery content	5
1.2 Block diagram.....	5
1.3 Main features	6
1.4 Board parameters and technical data	6
2 System and functional description	9
2.1 Getting started with EVAL-M1-IM241	9
2.2 Description of the functional blocks.....	15
2.2.1 Overview of IM241-L6T2B	15
2.2.2 Overview of ICE5GR4780AG	16
2.2.3 Motor external current feedback configuration and calculation	17
3 System design.....	19
3.1 Schematics	19
3.1.1 Auxiliary power supply.....	19
3.1.2 Inverter section using CIPOS™ Micro	19
3.2 Layout	21
3.3 Bill of material	24
3.4 Connector details	25
3.5 Test points	26
4 System performance	27
4.1 Heatsink thermal resistance test result.....	27
4.2 Test results for output ability.....	27
4.3 Test results for PWM range.....	29
4.4 Overcurrent protection	30
4.5 Short circuit protection.....	31
4.6 EMI test results	34
5 References and appendices	36
5.1 Abbreviations and definitions.....	36
5.2 References	36
5.3 Ordering details and other information	36
Revision history.....	37

The board at a glance

1 The board at a glance

The EVAL-M1-IM241 evaluation power board is a part of the iMOTION™ modular application design kit for motor drives (iMOTION™ MADK). The MADK platform is intended for use with various power stages and different control boards. The EVAL-M1-IM241 can easily be interfaced through the 20-pin iMOTION™ MADK M1 connector such as EVAL-M1-101T, and is intended for single-motor control only.

The EVAL-M1-IM241 evaluation board is available through regular Infineon distribution partners as well as on Infineon's website. The features of this board are described in the main features chapter of this document (UG-2021-01), whereas the remaining paragraphs provide information to enable the customers to copy, modify and qualify the design for production according to their own specific requirements.

Environmental conditions were considered in the design of the EVAL-M1-IM241, but the board is not qualified in terms of safety requirements or manufacturing and operation over the entire operating temperature range or lifetime. The boards provided by Infineon are subject to functional testing only.

The evaluation boards are not subject to the same procedures as regular products regarding returned material analysis (RMA), process change notification (PCN) and product discontinuation (PD). Evaluation boards are intended to be used under laboratory conditions by technical specialists only.

1.1 Delivery content

The EVAL-M1-IM241 evaluation board is designed to provide an easy-to-use power stage based on the Infineon's CIPOS™ Micro intelligent power module (IM241-L6T2B IPM).

The delivery includes the finished board as shown in Figure 1 and Figure 2. It provides a single-phase AC connector, an EMI filter, input rectifier, DC bus capacitors and 3-phase output for connecting the motor.

It also contains CoolSET™ based auxiliary power supply to provide 15 V & 3.3 V, emitter shunts for current sensing and overcurrent protection, and a voltage divider for DC-link voltage measurement. The board shown here can be operated directly with the required power supply without the need for additional components.

1.2 Block diagram

The block diagram of the EVAL-M1-IM241 is depicted in Figure 1.

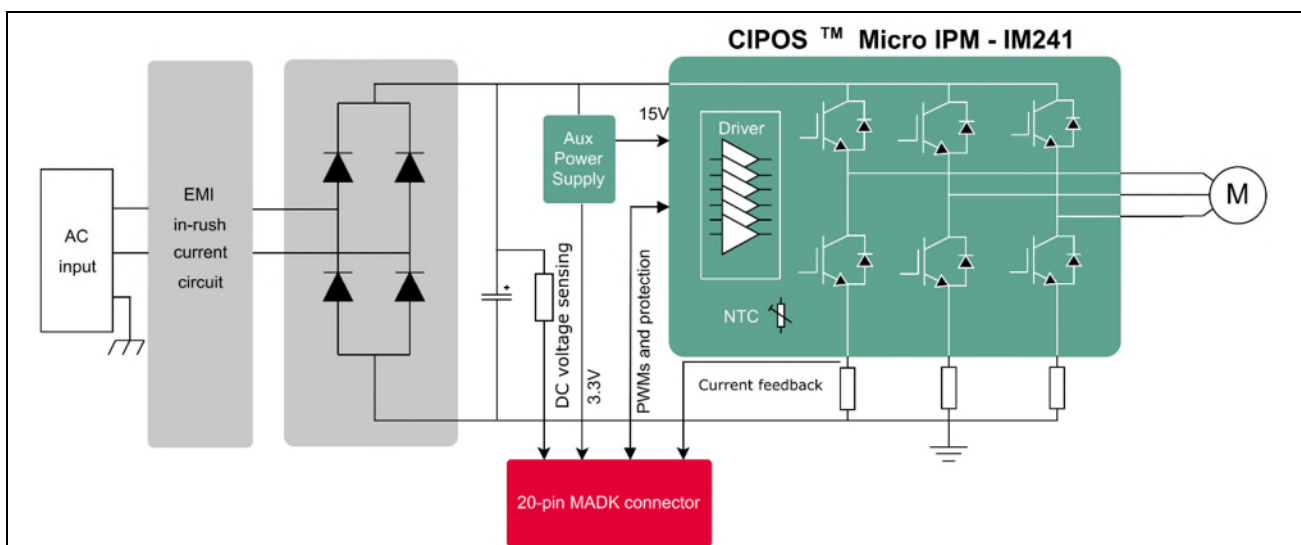

Figure 1 Block diagram of the EVAL-M1-IM241

The board at a glance

Figure 2 points out the functional groups on the top side of the EVAL-M1-IM241 design:

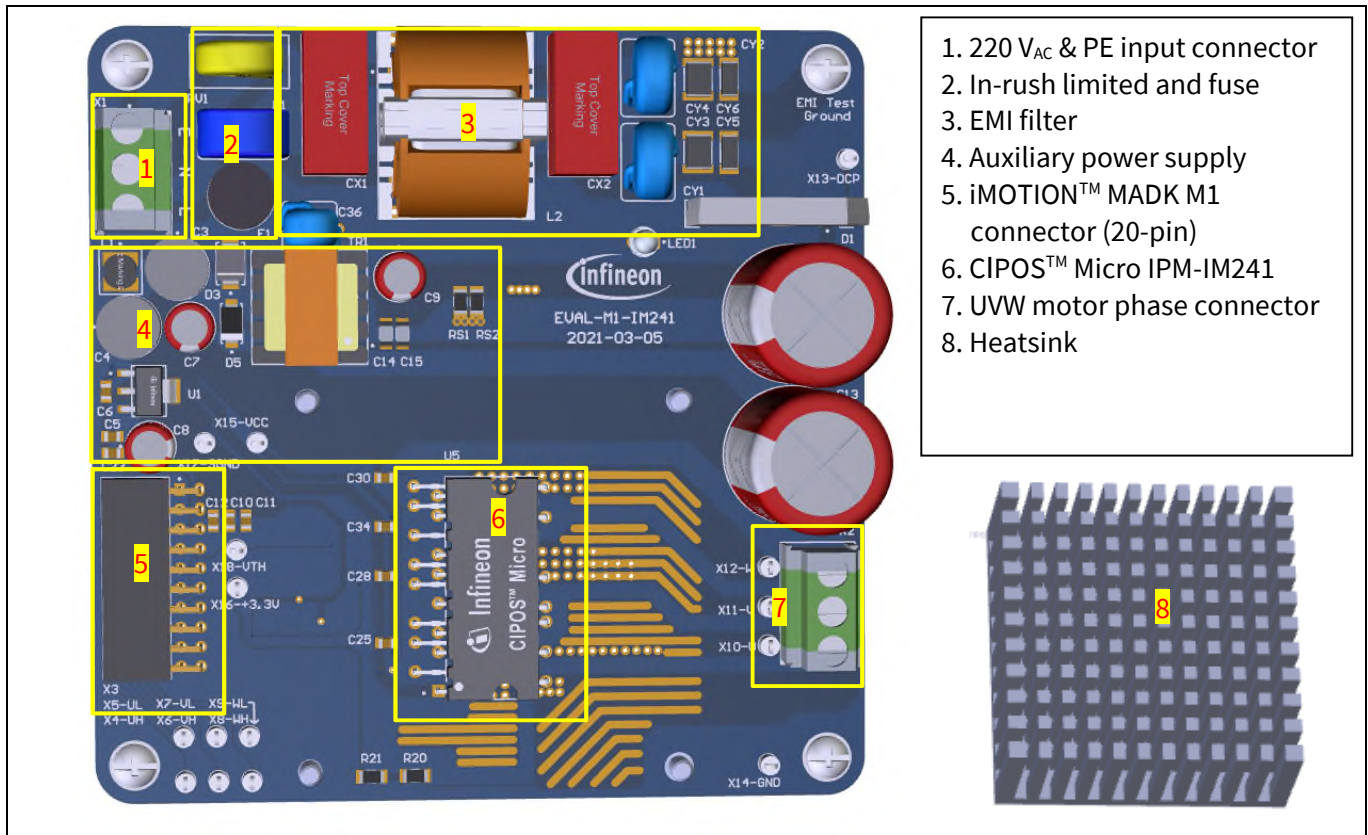

Figure 2 Functional groups of the EVAL-M1-IM241 reference design

1.3 Main features

The EVAL-M1-IM241 is an evaluation board for motor drive applications. Combined in a kit with one of the available MADK control board options, it demonstrates Infineon’s motion control IC and IPM technology for motor drives.

The evaluation board characteristics include:

- Input voltage 110~230 V_{AC}
- Maximum 2.5 A input current at 110V_{AC}
- Maximum 250 W motor power output at 220V_{AC}
- On board EMI filter and pass EMI standards EN55032
- Auxiliary power supply with 15 V, 3.3 V
- Overcurrent hardware protection & over temperature protection
- Sensing of DC-link voltage
- Thermistor output
- PCB is 100 mm × 100 mm, two layers with 2 oz. copper
- RoHS compliant

1.4 Board parameters and technical data

Table 2 depicts the important specifications of the evaluation board EVAL-M1-IM241.

The board at a glance

Table 2 Parameter

Parameter	Symbol	Conditions	Value	Unit
Input				
Input voltage	V_{AC}	Lower AC input, less motor power output	110 ~ 230	V_{rms}
Input current	$I_{AC(max1)}$	Input 220 V_{AC} , $f_{PWM}=6$ kHz, $T_a=25^{\circ}C$, $T_c=100^{\circ}C$, $P_{out}=250$ W	1.7	A_{rms}
	$I_{AC(max2)}$	Input 110 V_{AC} , $f_{PWM}=6$ kHz, $T_a=25^{\circ}C$, $T_c=100^{\circ}C$, $P_{out}=180$ W	2.5	A_{rms}
Output				
Power(3 phase)	$P_{out(max)}$	Input 220 V_{AC} , $f_{PWM}=6$ kHz, $T_a=25^{\circ}C$, $T_c=100^{\circ}C$	250	W
Current per leg	$I_{out(max)}$	Input 220 V_{AC} , $f_{PWM}=6$ kHz, $T_a=25^{\circ}C$, $T_c=100^{\circ}C$	1.4	A_{rms}
DC bus				
Maximum DC bus voltage	$V_{DC(max)}$	AC input 230 V_{rms}	325	V
Minimum DC bus voltage	$V_{DC(min)}$	AC input 110 V_{rms}	156	V
Current feedback				
Shunt Resistance	RS3,RS4,RS5	leg shunt	100	$m\Omega$
Protections				
Over current protection	I_{OCP}	Configured by either changing shunt resistors RS3, RS4, RS5 or adapting comparator threshold changing resistor R35	4 ¹	A_{peak}
Auxiliary power supply				
VCC voltage output	V_{CC}	Used for IPM power supply	15 ± 5%	V
VCC current output	I_{VCC}	Used for IPM power supply	100	mA
3.3 V voltage output	$V_{3.3V}$	Used for IMC controller and protection circuits	3.3 ± 1%	V
3.3 V current output	$I_{3.3V}$	Used for IMC controller and protection circuits	200	mA
PCB characteristics				
Dimension		Length × width	100 × 100	mm

¹ For iMOTION™ IC IMCxxx, there are three types of Gatekill input source options in MCEWizard setup: Gatekill-pin, Comparator and Both. If you select “comparator” mode, the external Gatekill signal will be not used, and the signal I_Shunt will be compared by the internal comparator with the “Device overcurrent trigger level setting” value set in MCEWizard.

The board at a glance

Parameter	Symbol	Conditions	Value	Unit
Material		FR4, 1.6 mm thickness, 2 oz. PCB		
System environment				
Ambient temperature	T_a		25	°C

2 System and functional description

2.1 Getting started with EVAL-M1-IM241

In order to run the motor system, a combination of the iMOTION™ MADK power board (EVAL-M1-IM241) and the matching MADK control board (EVAL-M1-101T or other control board) are required. This chapter provides more details on setting up the system and getting started with the iMOTION™ MADK development platform.

The EVAL-M1-IM241 evaluation boards are tested with EVAL-M1-101T controller boards, which shipped with embedded firmware and default parameters.

The following steps have to be performed in order to achieve a usable motor controller IC from a blank IMC101T:

- Programming of the motion control engine (MCE)
- Programming of parameter sets for system and motor
- Programming of customer scripts (optional)
- Programming of the combined file for an integrated system (optional)

The iMOTION™ software tools, MCEDesigner and MCEWizard, are required to initially set up the system, as well as to control and fine-tune the system performance to match the user's exact needs. These tools are available for download via the Infineon website ([Link](#)). Please visit this page periodically to check for tool/software updates.

iMOTION™ Link or on board USB-to-UART cable is needed to bridge the PC/debugger side and motor drive system (the target iMOTION™ device, hot side) with 1 kV DC galvanic isolation.

This chapter provides more details on setting up the system and getting started with the iMOTION™ development platform.

After downloading and installing the iMOTION™ PC tools, MCEWizard and MCEDesigner, the following steps need to be taken to run the motor. Refer to MCEWizard and MCEDesigner documentation for more information.

EVAL-M1-IM241 user guide

iMOTION™ modular application design kit

System and functional description

Figure 3 shows the basic system connection using EVAL-M1-IM241 to run a 400 W GK6040-6AC31-WEZ1 motor with MCEDesigner.

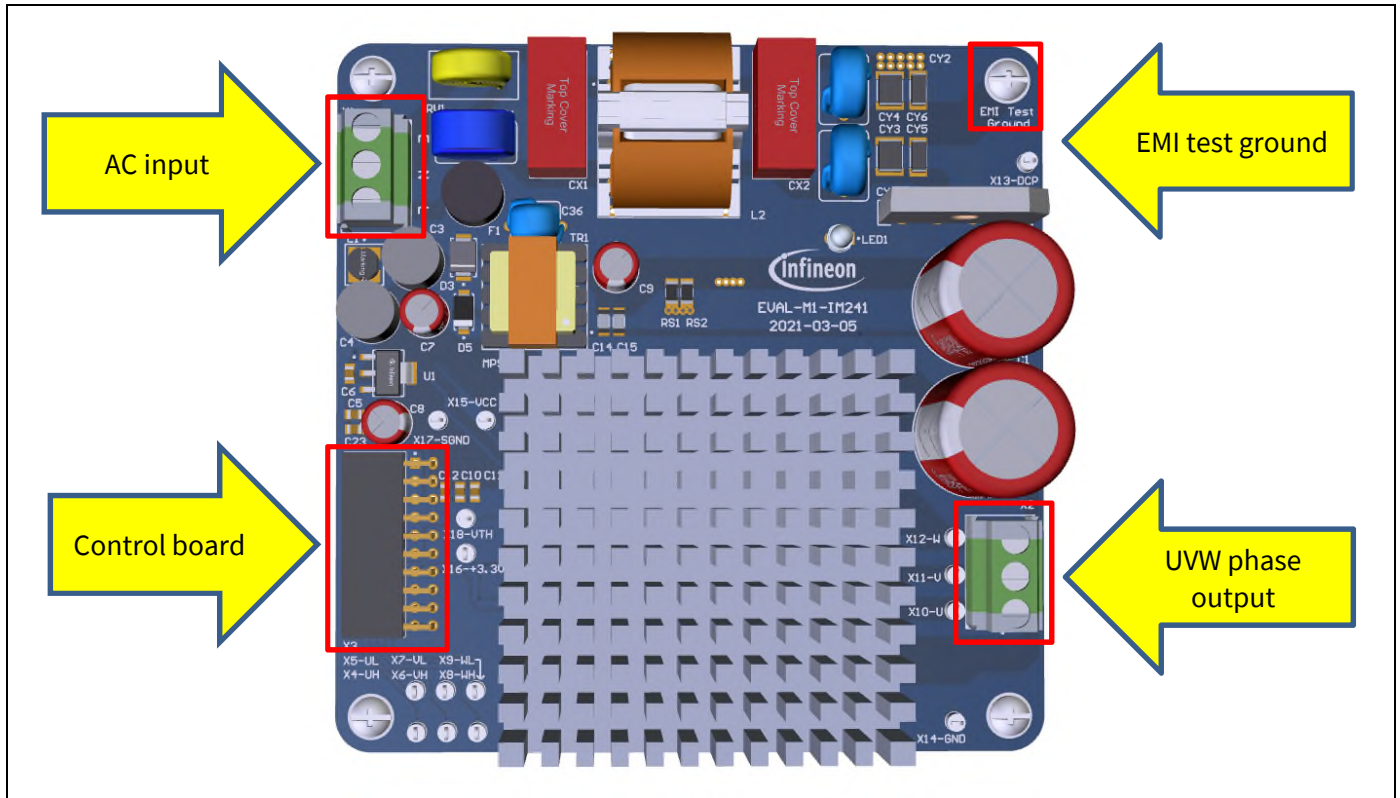

Figure 3 System connection example



Figure 4 MCEWizard welcome page

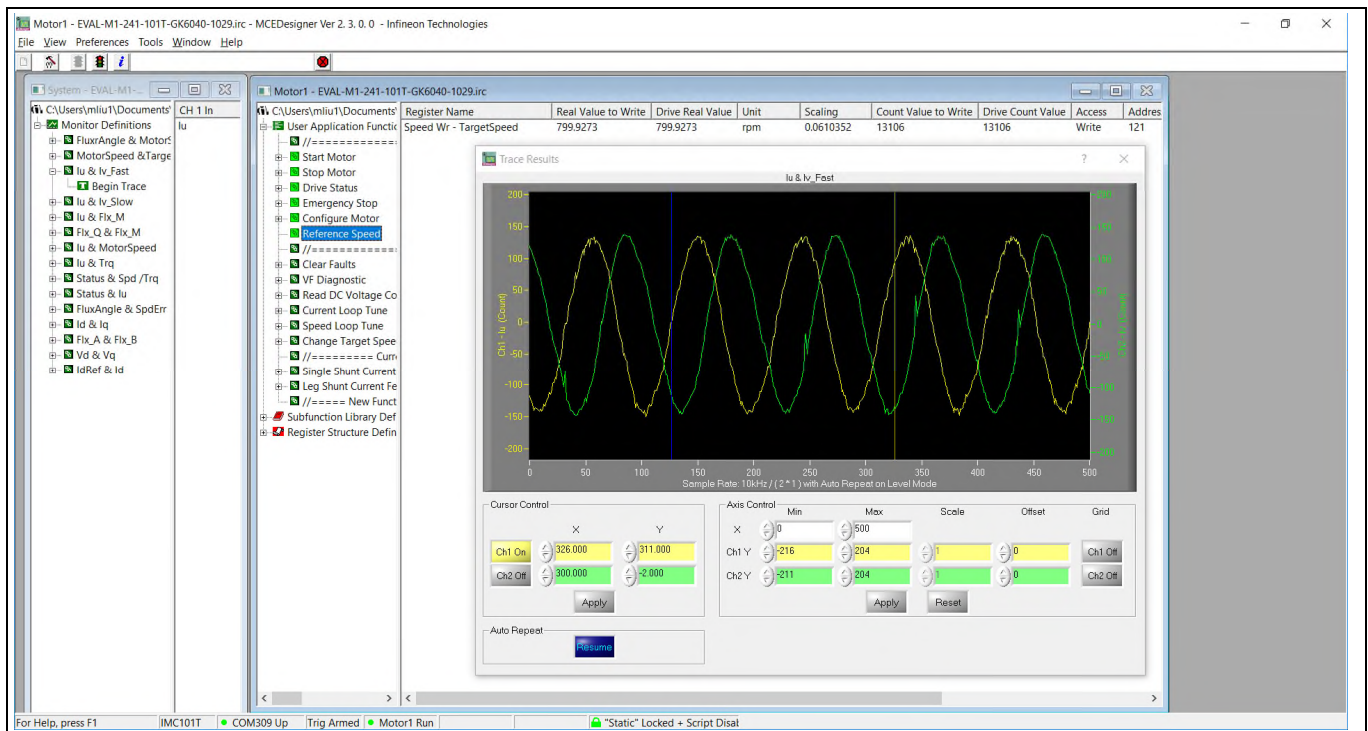

Figure 5 MCEDesigner user interface

Here are the steps needed to run the motor:

1. Connect EVAL-M1-101T control board to EVAL-M1-IM241, and connect PC-USB connector to EVAL-M1-101T.
2. Connect 220 V AC power supply and UVW outputs to the motor.
3. Use MCEWizard to enter the target motor’s system and operating parameters, as well as evaluation board’s hardware parameters, which will then be used to calculate the digital parameter set of the controller representing the complete motor drive system.
4. After system and operating parameters are set, go to the “Verify & Save Page” and click on “Calculate Parameters” button. If no errors are reported, then save the drive parameter set into your project directory by clicking “Export to MCEDesigner file (.txt)” (Figure 6); if an error is detected, double-click on the error message (highlighted in RED) and adjust the related parameter. The saved drive system parameter file will be later used by the MCEDesigner in step 9.

Note: (Please refer to MCEWizard_V2.3.0.0 User Guide.pdf for more details, which is in MCE Wizard’s install path)

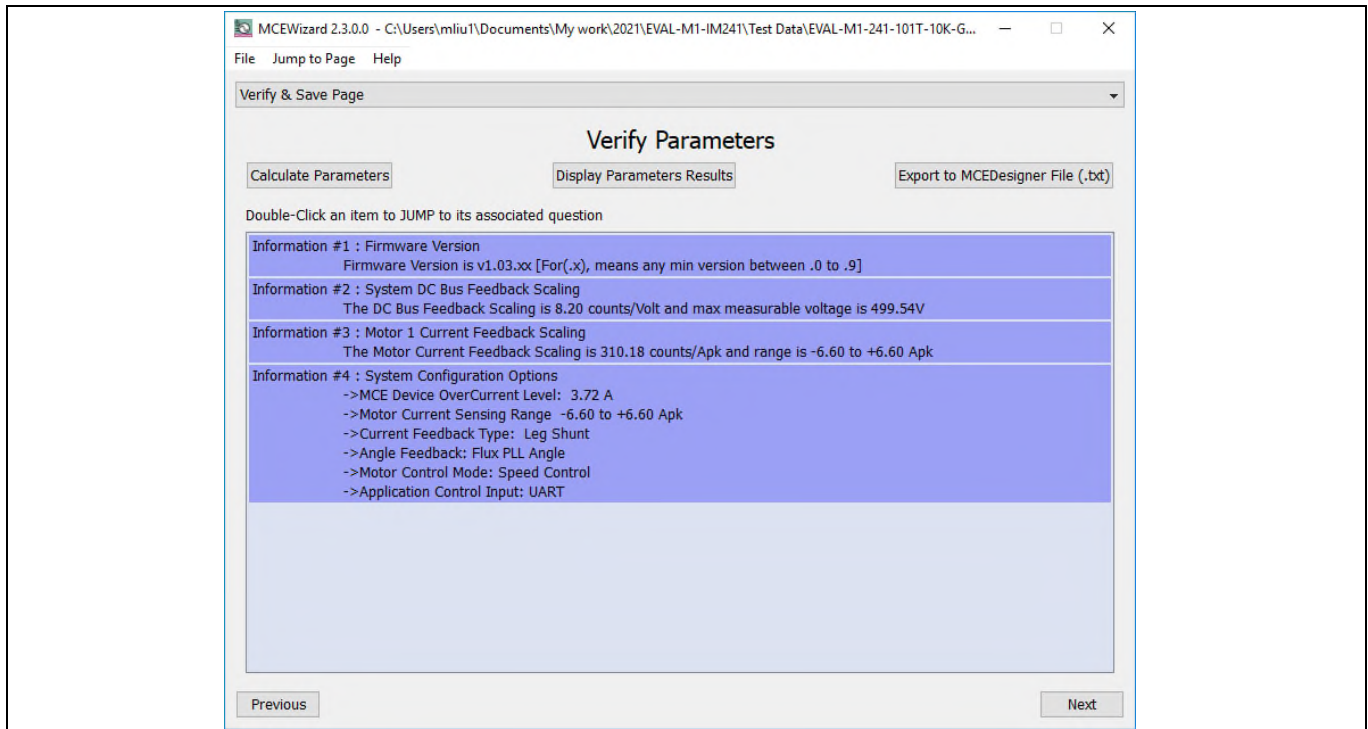

Figure 6 MCEWizard Verify and Save page

5. Turn on 220 V AC power supply, red LED1 & LED2 ON.
6. Start MCEDesigner tool and open MCEDesigner default configuration file (.irc) for IMC101T device (IMC101T_Vxxx.irc) by clicking “File” > “Open”.
(IMC101T_Vxxx.irc file is included in downloaded “IMC101T MCE Software Package”)
7. MCEDesigner should automatically connect to the EVAL-M1-101T board using default COM port (Indicated by green circle next to “COMx Up” status in the bottom frame of the MCEDesigner GUI). If it cannot establish the connection due to incorrect COM port, change COM port by doing the following steps: click on the “System Page” window and then click on “Preferences > Connection > Connect using”, and choose one of the other available COM ports from the drop-down list.
8. In case of blank IC: If the firmware has been erased from the IMC101T, a warning message will pop up (Figure 7) saying “Target device firmware and parameters files are not programmed! Please program firmware and parameters file.” See step 9 on how to obtain/program firmware and parameters.

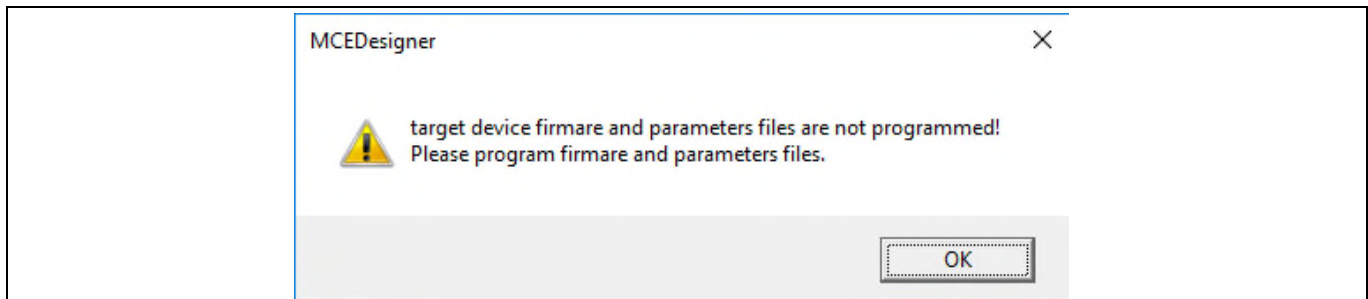

Figure 7 MCEDesigner warning message

9. In case of blank IC: Take the following steps to program the firmware and the parameters file into the internal Flash memory of iMOTION™ Control IC: Click on system page, click “Tools” > “Programmer” and select “Program Firmware and Parameters,” shown as Figure 8 below. The encrypted firmware is available in “IMC101T MCE Software Package,” regarding the parameters file, browse and select the .txt file in step 3.

System and functional description

(If blank IMC101T IC, MCE Designer will pop up information “Target device firmware and parameter files are not programmed!”) Program the MCE firmware and system parameters into the internal Flash memory of iMOTION™ IC by clicking “Tools > Programmer” in the pull-down menu, and then clicking on the “Program Firmware and Parameter” check box. Select right parameter file and firmware file. Finally click “Start” button to program firmware and parameter. Then click YES and then the OK button to update IRC file with parameter file; finally “Save As” the IRC file to your own file name that contains COM config, Parameters & firmware file path information.

Note: Please refer to MCEDesigner User Guide.pdf and MCEDesigner_V2.3.0.0 Application Guide.pdf for more details, which is in MCE Designer’s install path

Red LED1 on EVAL-M1-101T will flash on after the program is done.

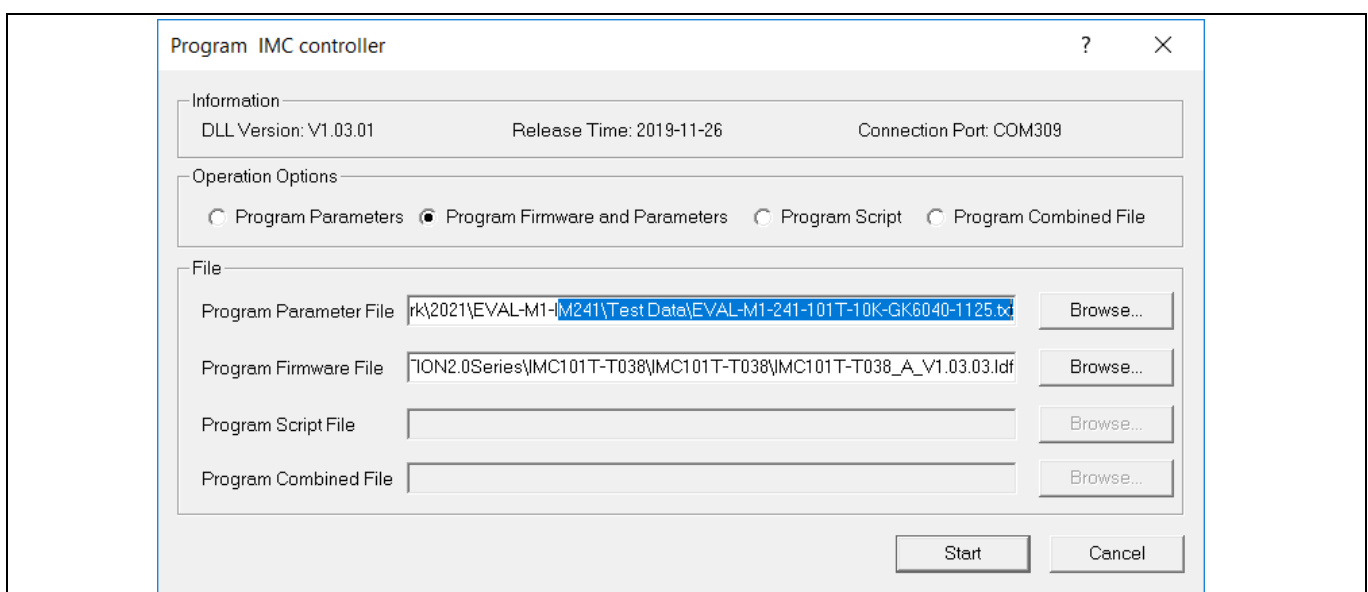

Figure 8 MCEDesigner program page

10. Double click “VF Diagnostic” function in motor1 page, monitor motor current with oscilloscope. If motor current is not sinusoidal, change target speed and Vd_Ext in VF Diagnostic sub-function, then double-click “VF Diagnostic” until oscilloscope shows a steady sinusoidal current, with amplitude of 30~50% motor rate current.

Double-click “Iu & Iv_Slow” in System page > Monitor Definitions, the motor current feedback would be very clean and sinusoidal, as shown in Figure 9, otherwise please tune “Gating Propagation Delay & Phase Shift Window Size” in MCE Wizard. The sampled motor current noise amplitude should be less than 50 ~100 counts (below 5% of motor current, or below 5% of max AD range 2048 counts); otherwise, motor current sample related hardware and setup need tuning.

“VF Diagnostic” sub function can verify:

- If motor is correctly connected
- If IGBT / MOS & gate driver work as expected
- If current sensing related parameters are correctly configured
- If PCB layout and DC bus decouple have been done correctly

After “VF Diagnostic” is done, click STOP button (the red traffic light button) to stop PWM.

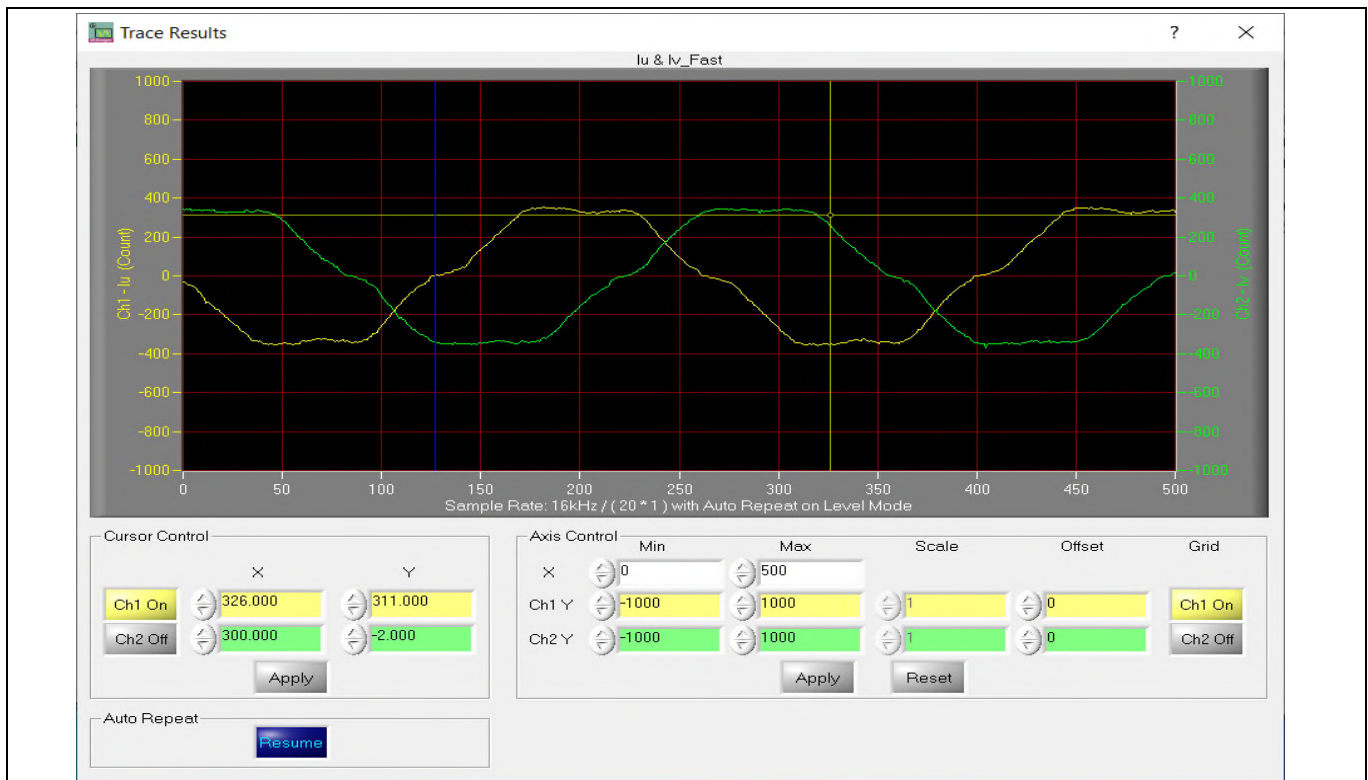

Figure 9 Trace waveform for lu & lv open loop diagnostic

11. Start the motor by clicking the green traffic light button in the control bar (or double-click Start Motor sub function in Motor1 page, group of User Application Function Definitions); motor runs if above step goes well.
12. Check motor spin direction, adjust UVW connection order or set negative target speed in MCE Designer if direction is wrong.
13. Set target speed to about 50% of MAX speed, start “lu & Flx_M” trace with “Auto Repeat On Level,” see Figure 10. Flx_M is better within the range of 2000~2500 (rated value is 2048), and must be steady and DC-like.

Some key tips for better motor-performance tuning:

- If Flx_M is not steady (swinging or oscillating), double-check motor parameters, speed loop PI gain, flux Estimator time constant and PLL PI bandwidth (parameters PLLKp & PLLKi) related setup.
- If Flx_M is very noisy, double-check current feedback and Vdc-related hardware and parameters.
- If Flx_M is far from 2048, “Motor Back EMF Constant (K_e)” needs to be adjusted in MCE Wizard.

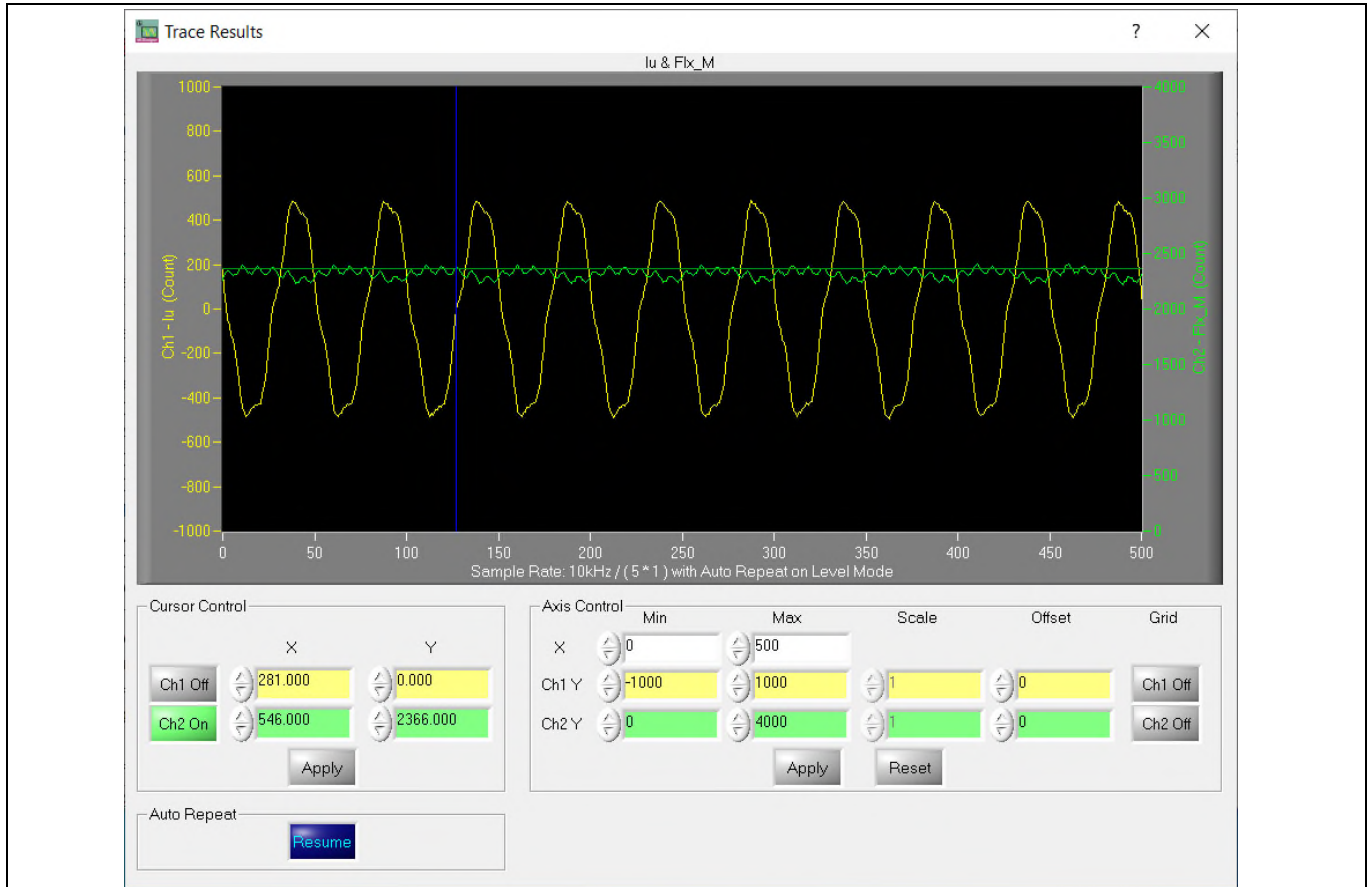

Figure 10 Trace waveform for Iu & Flx-M at 50% speed

14. Once the firmware has been programmed, in case a new parameter file has to be programmed, follow the same instructions given in step 9. In this case, firmware programming is no longer needed and it is possible to select the first option “Program Parameters.”

Note: For detailed information on controller programming, refer to AN2018-33 iMOTION™ 2.0 Device Programming, MCEDesigner documentation and MCEWizard documentation.

2.2 Description of the functional blocks

The motor inverter of EVAL-M1-IM241 reference design is implemented by the IM241 module, and the auxiliary power supply is based on fixed frequency CoolSET™ ICE5GR4780AG.

2.2.1 Overview of IM241-L6T2B

Figure 11 illustrates the internal block diagram of the CIPOS™ Micro IPM IM241-L6T2B.

Main features include:

- 600 V 3-phase inverter including gate drivers & bootstrap function
- Reverse Conducting IGBT Gen 2 (RCD2) optimized for motor drives
- Temperature monitor
- Accurate overcurrent shutdown ($\pm 5\%$)
- Fault reporting and programmable fault clear
- Advanced input filter with shoot-through protection

EVAL-M1-IM241 user guide

iMOTION™ modular application design kit

System and functional description

Main features of ICE5GR4780AG include:

- Integrated 700 V/ 800 V avalanche rugged CoolMOS™
- Enhanced Active Burst Mode with selectable entry and exit standby power
- Digital frequency reduction for better overall system efficiency
- Fast startup achieved with cascode configuration
- DCM and CCM operation with slope compensation
- Frequency jitter and soft gate driving for low EMI
- Built-in digital soft start
- Integrated error amplifier to support direct feedback in non-isolated flyback
- Comprehensive protection with input line over voltage protection, VCC over voltage, VCC under voltage, overload/open loop, over temperature
- All protections are in auto restart mode
- Limited charging current for VCC short to GND

2.2.3 Motor external current feedback configuration and calculation

The current input value is product of the shunt resistance in milliohms and gain of external current sense amplifier for EVAL-M1-101T as shown in Figure 13.

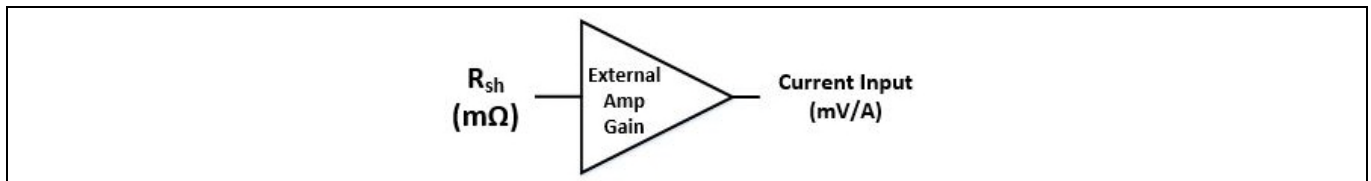

Figure 13 Current shunt feedback and sample timing for EVAL-M1-101T

The external amplifier gain circuit can be found in the schematics or user manual for the control board (For example, EVAL-M1-101T see Figure 14).

Figure 14 depicts IU+ current feedback sensing circuitry on EVAL-M1-101T evaluation board. Please note that the default external amplification gain is less than 1 for current sense in this evaluation board.

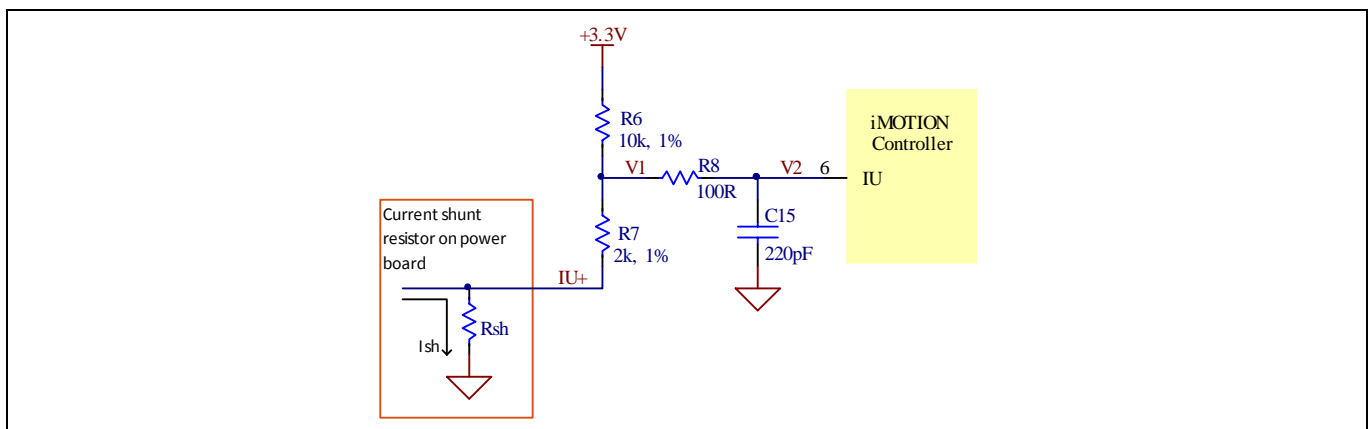

Figure 14 The part of Current feedback on the EVAL-M1-101T evaluation board

System and functional description

Based on the principle of Kirchhoff's voltage law,

$$V_2 \approx V_1 \approx (V_{DD} - I_{sh} * R_{sh}) * \frac{R_7}{R_6 + R_7} + I_{sh} * R_{sh} = \frac{R_7}{R_6 + R_7} V_{DD} + \frac{R_6}{R_6 + R_7} R_{sh} * I_{sh}$$

$$\text{current input} = \frac{R_6}{R_6 + R_7} R_{sh} = \frac{5}{6} R_{sh}$$

Based on this calculation, the current input for the MADK combination of EVAL-M1-101T and EVAL-M1-IM241 is 83.3 mV/A.

System design

3 System design

The EVAL-M1-IM241 board is an optimized design for 220 V small home appliances like fan applications. To meet individual customer requirements and to make the EVAL-M1-IM241 reference design a basis for development or modification, all board design data such as schematics, Gerber and AD files can be found on the Infineon homepage.

3.1 Schematics

3.1.1 Auxiliary power supply

Figure 15 depicts the schematic of the auxiliary power supply for the EVAL-M1-IM241 board. The circuit includes the latest CoolSET™ 5(ICE5AR4780AG) of Infineon and flyback topology, directly output 15 V and 6 V. V_{CC} is connected to the gate drivers inside the CIPOST™ IPM.

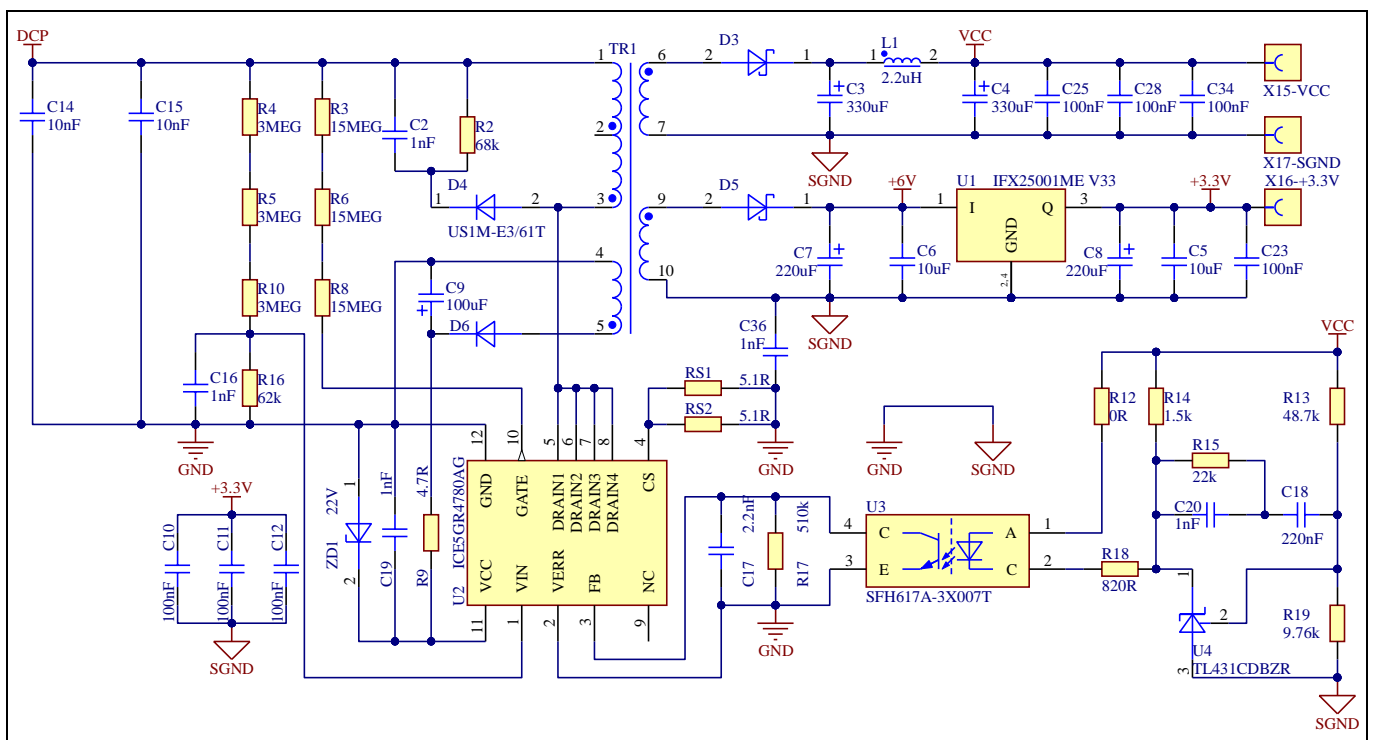

Figure 15 Auxiliary power supply of EVAL-M1-IM241

The linear voltage regulator IFX25001ME V33 generates 3.3 V from 6 V power supply V_{CC}. The 3.3 V power supply is used in the inverter external overcurrent comparator circuit. Both V_{CC} and 3.3 V are also present on the 20-pins iMOTION™ MADK-M1 interface connector X3 to power circuitry on the control board.

3.1.2 Inverter section using CIPOST™ Micro

The inverter section is implemented using the CIPOST™ Micro IPM as sketched in Figure 16. The module includes a combination of reverse conducting IGBT Gen 2 (RCD2) optimized and the industry benchmark rugged half-bridge drivers. The shunt resistor section is also given, including the 0 Ω resistors R23, R24, R25, R26 and R27. These resistors allow leg shunt or single shunt via different combinations. The three capacitors C24, C26 and C33 are used as bootstrap capacitors to provide the necessary floating supply voltages VBS1, VBS2 and VBS3 respectively.

System design

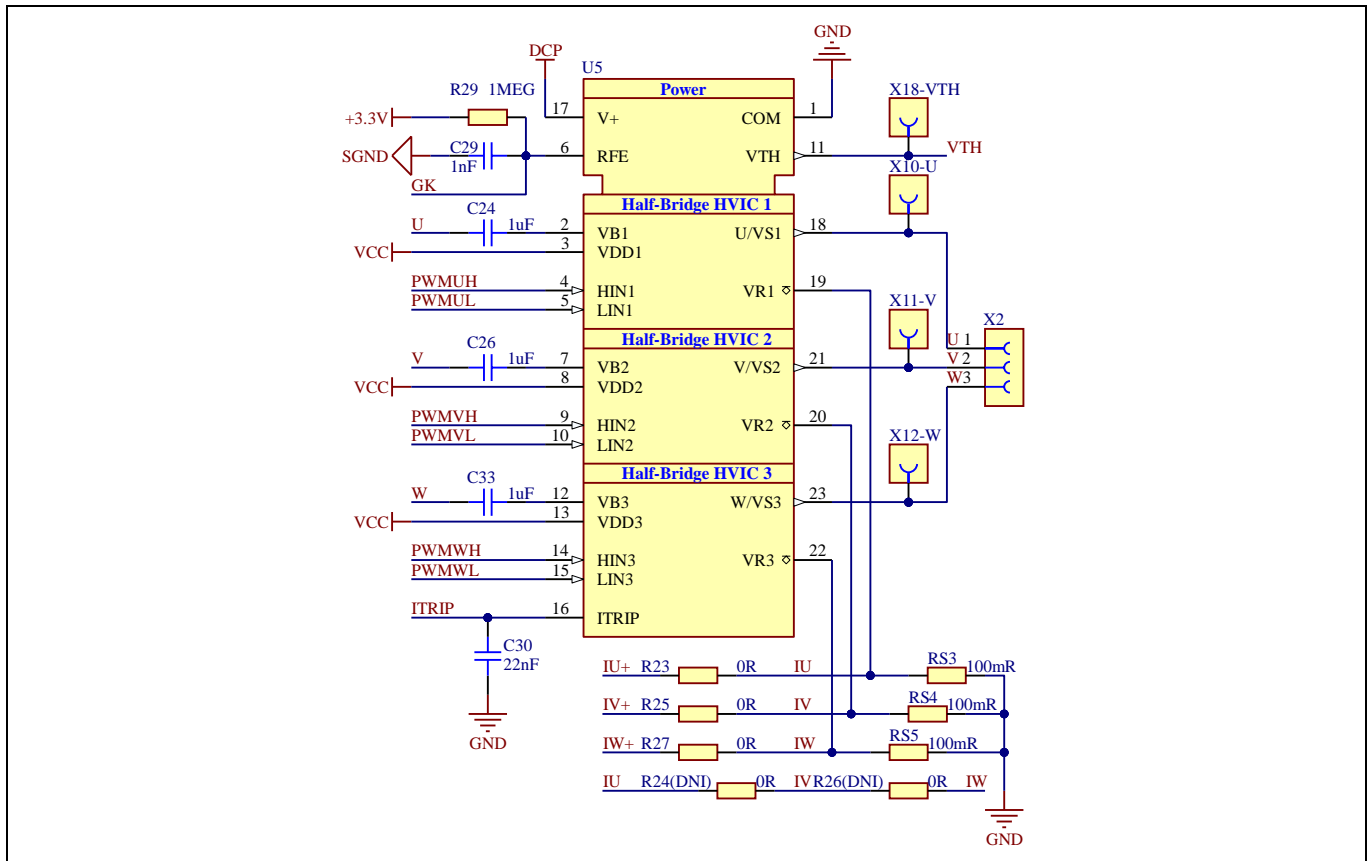

Figure 16 Schematics for IM241 IPM and peripheral circuit

System design

3.2 Layout

This board has two electrical layers with 140 µm copper (2 oz. copper) and dimensions of 100 mm × 100 mm. The thickness of the PCB board is 1.6 mm. Figure 17 illustrates the top assembly print of the reference design.

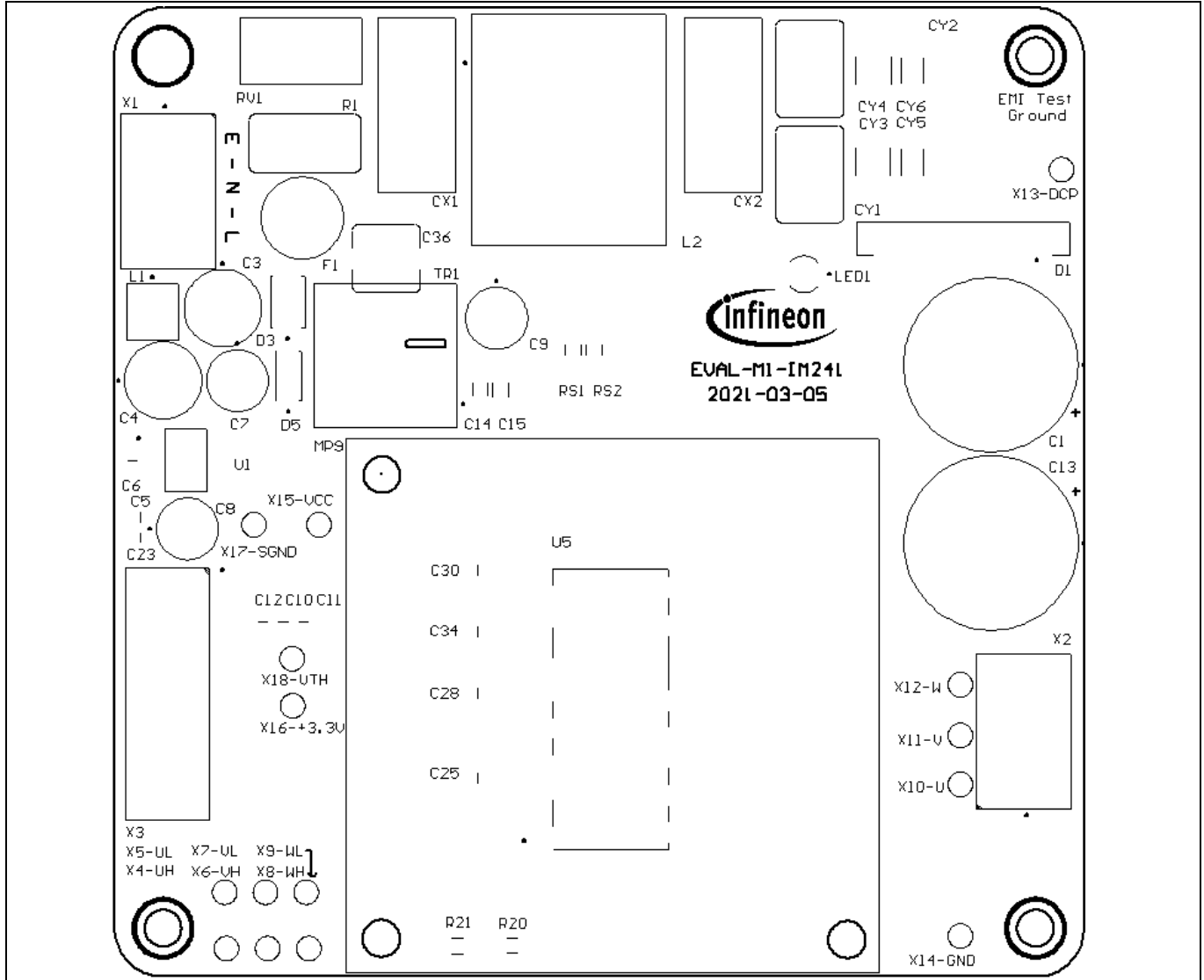

Figure 17 Top assembly print of the EVAL-M1-IM241

System design

Figure 18 depicts the bottom assembly print of the evaluation board.

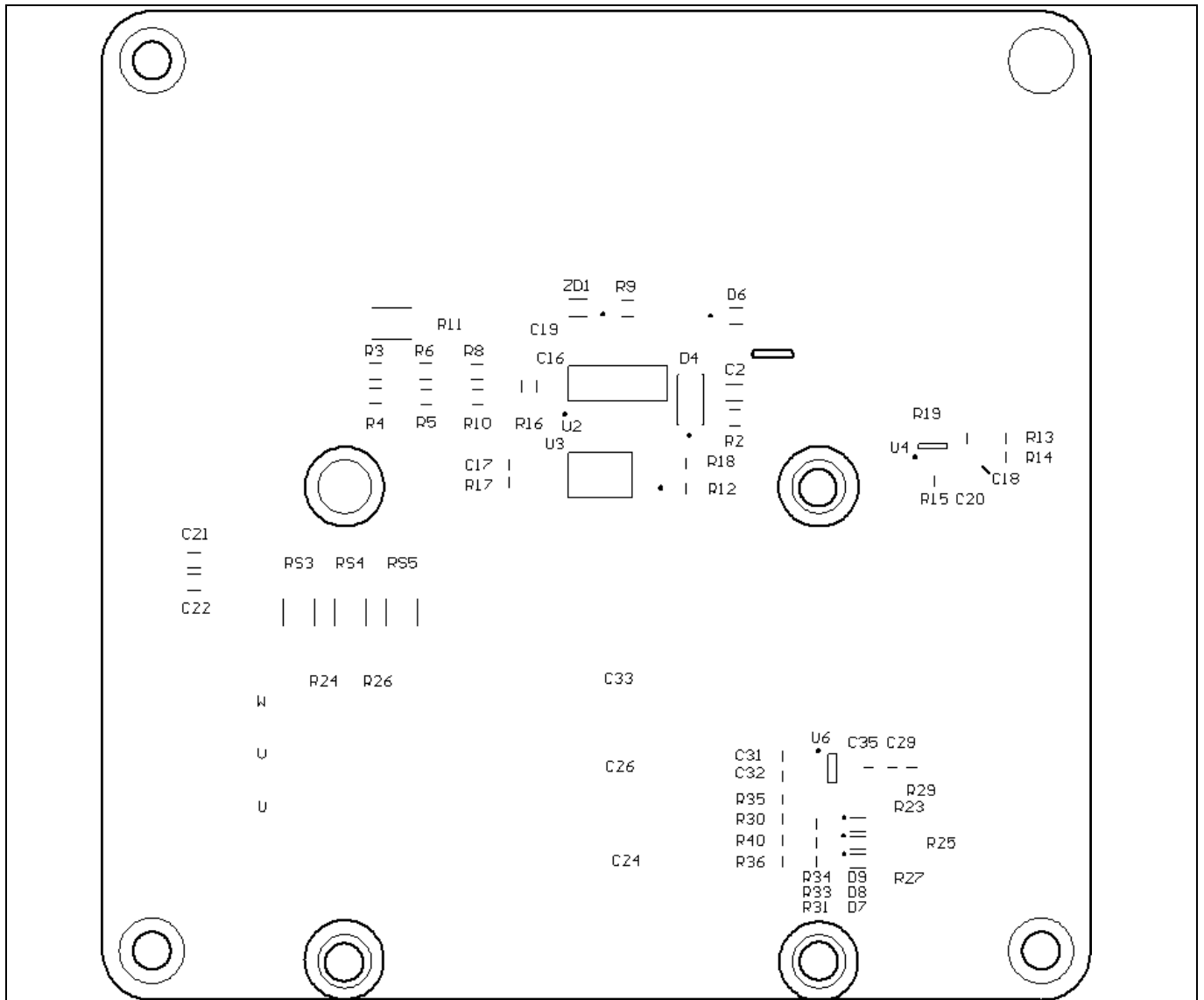

Figure 18 Bottom assembly print of the EVAL-M1-IM241

The top layer of the PCB is provided in Figure 19.

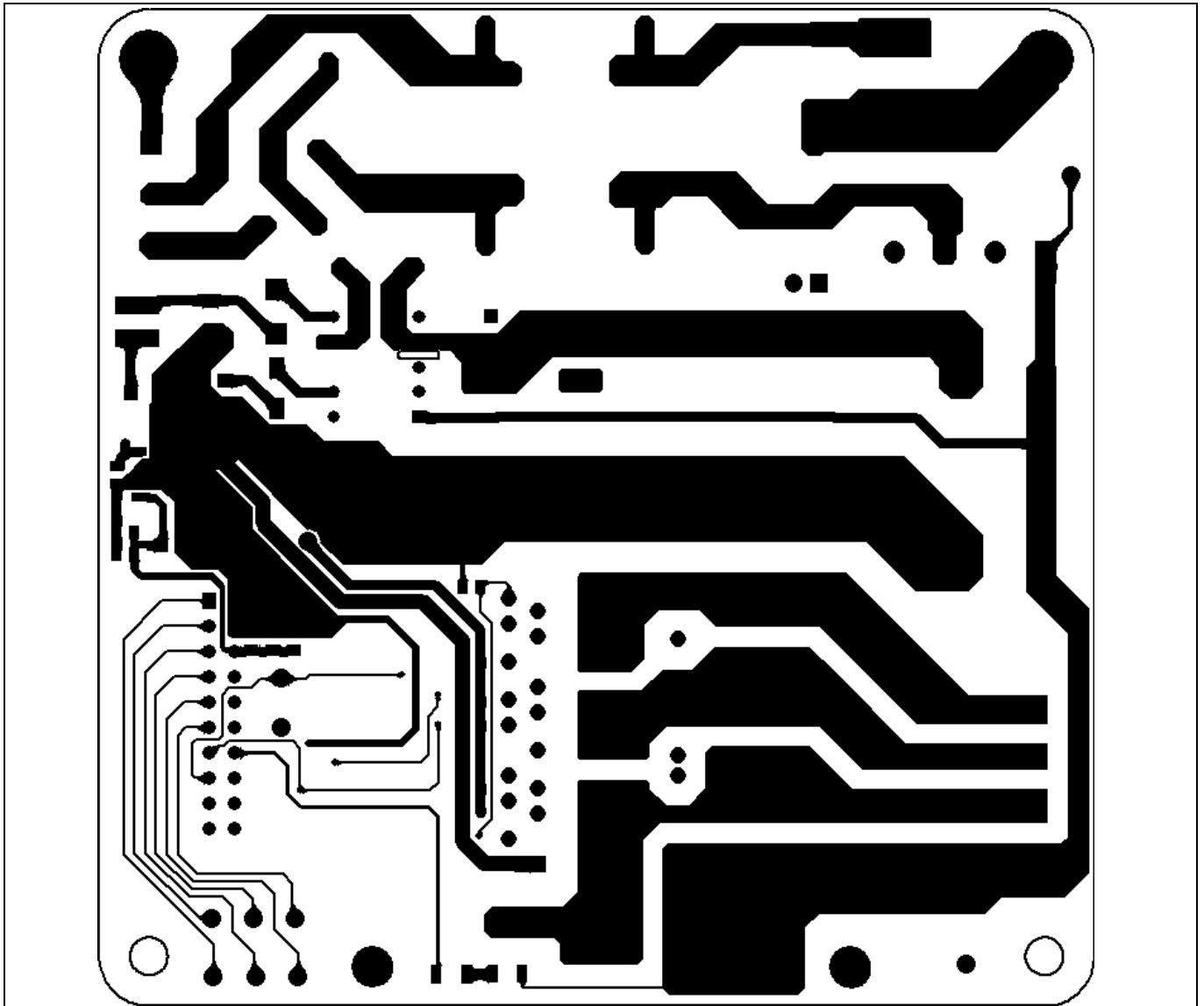

Figure 19 Top layer of the EVAL-M1-IM241

System design

Figure 20 illustrates the bottom layer routing of the PCB.

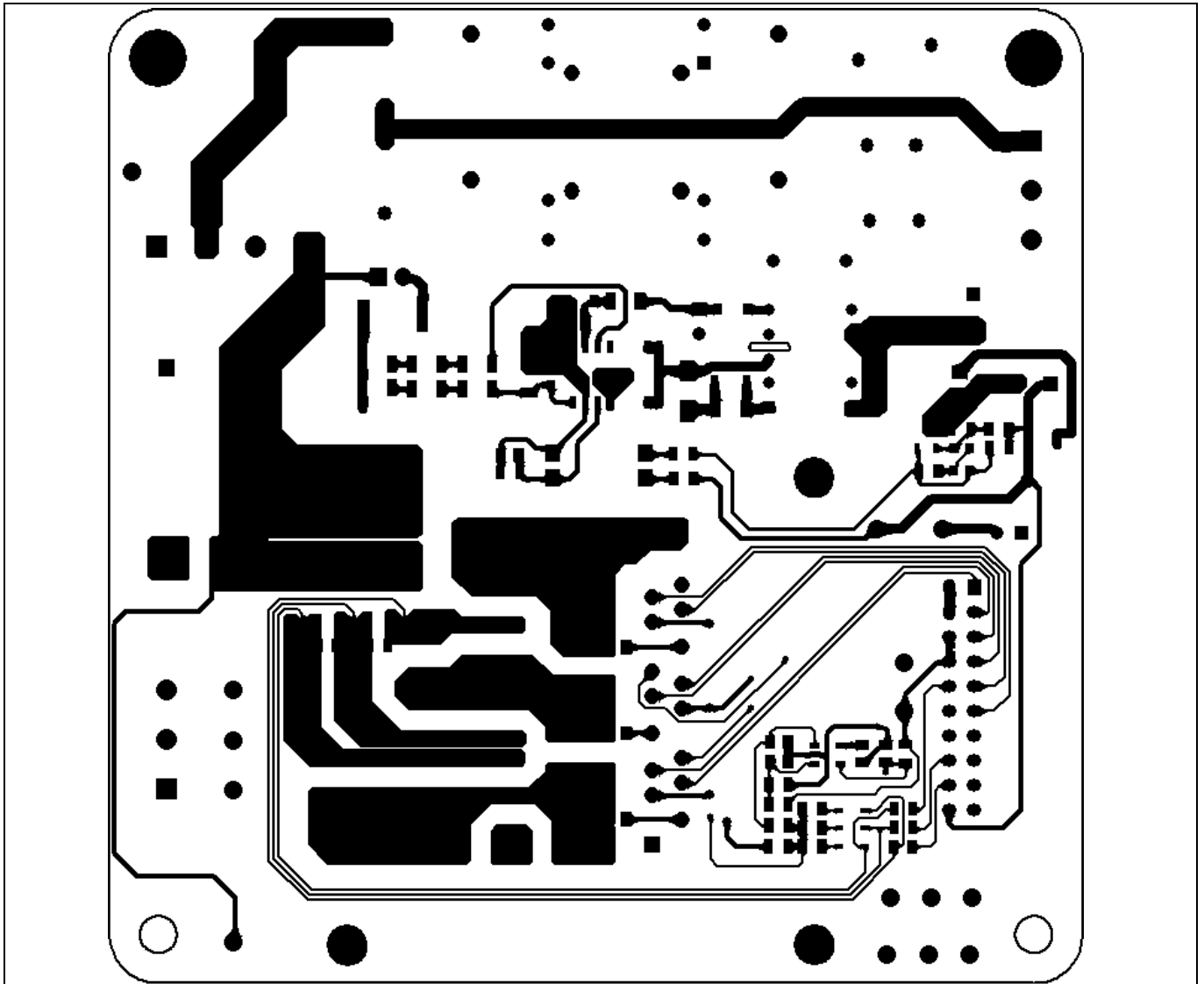

Figure 20 Bottom layer of the EVAL-M1-IM241

3.3 Bill of material

The complete bill of material is available on the download section of the Infineon homepage. A log-in is required to download this material.

Table 3 BOM of the most important/critical parts of the evaluation

S. No.	Ref Designator	Description	Manufacturer	Manufacturer P/N
1	U1	IC REG LIN 3.3 V 400 mA SOT223-4	Infineon Technologies	IFX25001MEV33
2	U2	AC-DC Power Conversion	Infineon Technologies	ICE5GR4780AGXUMA1
3	U5	CIPOS™ Micro IPM IM241-L6T2B	Infineon Technologies	

System design

S. No.	Ref Designator	Description	Manufacturer	Manufacturer P/N
4	CX1, CX2	CAP FILM 470 nF 630 V 10% MKP (Metallized Polypropylene)	Wurth Elektronik	890324025039CS
5	CY3, CY4	CAP CSSA Multilayer Ceramic Chip Safety Capacitor X1/Y2 470 pF 250 VAC	Wurth Elektronik	8853522110011
6	C1, C13	CAP ELCO 150 uF 400 V 20% Aluminium electrolytic	Wurth Elektronik	860021381022
7	L2	Common choke	Yunlu Energy Technology	0324510376A

3.4 Connector details

General information about the connectors of the EVAL-M1-IM241 reference design is provided in this section. Table 4 includes the details of the AC input connector.

Table 4 AC input connector (X1)

Pin	Label	Function
1	E	Earth ground
2	N	AC neutral input
3	L	AC line input

Table 5 provides the details of the motor UVW output connector X2.

Table 5 Motor side connector (X2)

Pin	Label	Function
1	U	Connected to motor phase U
2	V	Connected to motor phase V
3	W	Connected to motor phase W

Table 6 provides the pin assignments of the 20-pin iMOTION™ MADK-M1 interface connector X3. This connector is the interface to the controller board.

Table 6 X3 - iMOTION™ MADK-M1 20-pin interface connector for controller board

Pin	Name	Pin name connectors
1	PWMUH	3.3 V compatible logic input for high side gate driver-Phase U
2	GND	Ground
3	PWMUL	3.3 V compatible logic input for low side gate driver-Phase U
4	GND	GND ground
5	PWMVH	3.3 V compatible logic input for high side gate driver-Phase V
6	+3.3 V	On board 3.3 V supply
7	PWMVL	3.3 V compatible logic input for low side gate driver-Phase V

System design

Pin	Name	Pin name connectors
8	+3.3 V	On board 3.3 V supply
9	PWMWH	3.3 V compatible logic input for high side gate driver-Phase W
10	I_U	Positive current sense output
11	PWMWL	3.3 V compatible logic input for low side gate driver-Phase W
12	I_U-	Negative current sense output or ground
13	GK	Gatekill signal – active low when overcurrent is detected
14	DCBSense	DC bus positive voltage, scaled in 0-3.3 V range by a voltage divider
15	VTH	Thermistor output
16	I_V	Not used
17	I_V-	Not used
18	I_W	Not used
19	I_W-	Not used
20	VCC	15 V power supply

3.5 Test points

Table 7 provides the assignments of the on-board test points.

Table 7 The test point for signal measurement

Pin	Name	Functions & net label describe
X4	PWMUH	3.3 V compatible logic input for high side gate driver-Phase U
X5	PWMUL	3.3 V compatible logic input for low side gate driver-Phase U
X6	PWMVH	3.3 V compatible logic input for high side gate driver-Phase V
X7	PWMVL	3.3 V compatible logic input for low side gate driver-Phase V
X8	PWMWH	3.3 V compatible logic input for high side gate driver-Phase W
X9	PWMWL	3.3 V compatible logic input for low side gate driver-Phase W
X10	U	Inverter output, motor phase U
X11	V	Inverter output, motor phase V
X12	W	Inverter output, motor phase W
X13	DCP	DCP bus voltage test point
X14	GND	GND test point
X15	15 V	15 V supply
X16	3.3 V	3.3 V supply
X17	SGND	SGND test point
X18	VTH	Test point for temperature sensing

4 System performance

4.1 Heatsink thermal resistance test result

In order to test the thermal impedance of heatsink to ambient R_{thCA} , the DC source is used to conduct the IPM internal diodes, as shown in Figure 21. With the DC source voltage increasing, current through IPM I_{IPM} and voltage on IPM V_{IPM} are monitored by current and voltage meter, the IPM case-temperature test point is between IPM and heatsink, the same as T_C point of inverter IGBT of the IPM datasheet.



Figure 21 Heatsink thermal testing set-up

Thermal resistance between junction and ambient R_{thJA} is divided into 2 parts as in the following formula: thermal resistance between junction to case R_{thJC} and thermal resistance between case to ambient R_{thCA} .

$$R_{thJA} = R_{thJC} + R_{thCA}$$

Thus, we get the following formula:

$$R_{thCA} = \frac{\Delta T_{CA}}{P_{D.tot}} = \frac{T_C - T_A}{V_{IPM} \times I_{IPM}}$$

The final case-to-ambient resistance value is roughly:

$$R_{thCA} = 7 \text{ } ^\circ\text{C}/\text{W}$$

4.2 Test results for output ability

In order to test the total output power capability of EVAL-M1-IM241 design, the IPM case temperature is tested with different MADK input power and motor output current.

The test conditions are:

- Ambient temperature $T_a=25^\circ\text{C}$
- Passive heatsink without fan
- AC input is $V_{AC}=220 \text{ V}/50 \text{ Hz}$
- PWM frequency 6 kHz
- GK6040 motor

System performance

The module case temperature vs output power is shown as Figure 22. R_{thCA} is based on the existing heatsink on the evaluation board and without fan cooling.

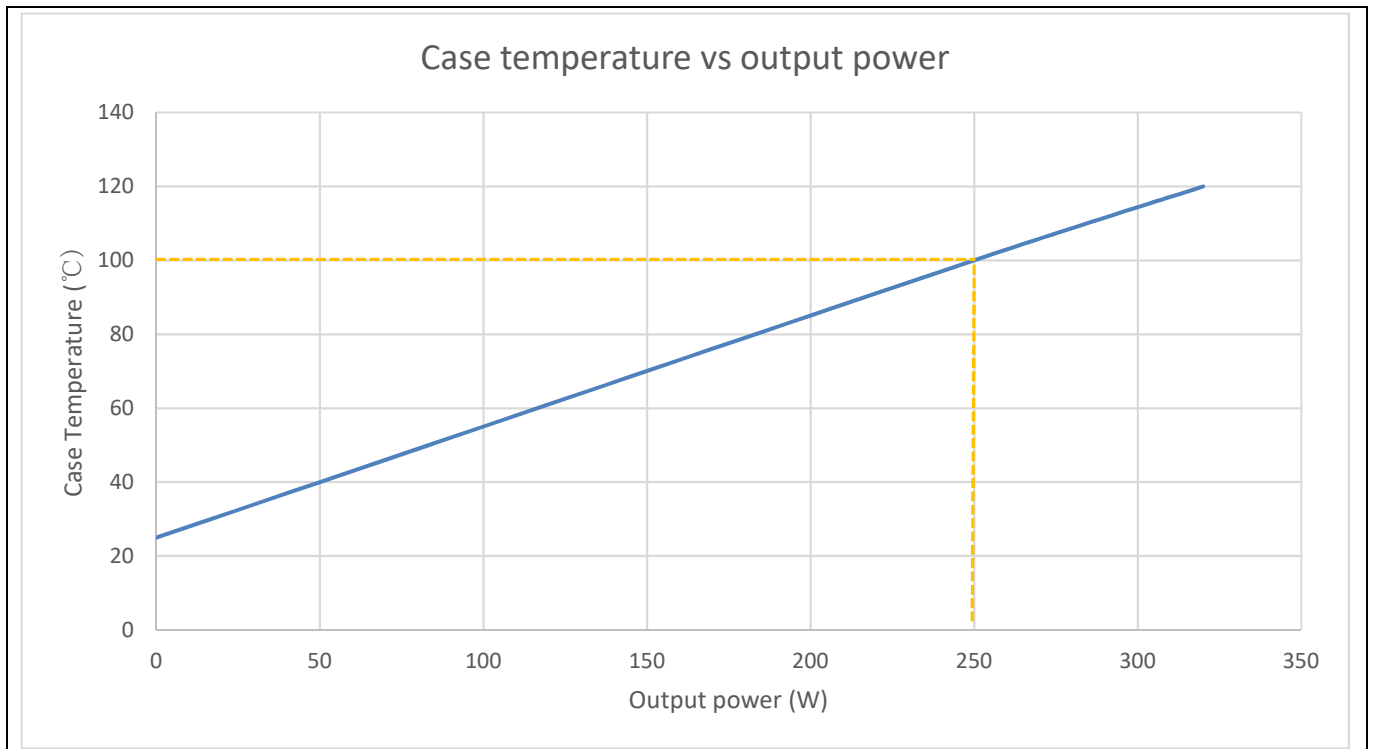

Figure 22 The module case temperature vs output power

System performance

4.3 Test results for PWM range

Figure 23 shows the output ability at different PWM frequencies, which are performed under the following conditions:

- 6~20 kHz PWM, three-phase modulation
- The case temperature of IM241-L6T2B reaches 100°C
- Ambient temperature $T_a=25^\circ\text{C}$
- Passive heatsink without fan
- AC input voltage is $V_{AC}=220\text{ V}/50\text{ Hz}$ (V_{DC} bus is 300 V~310 V)
- GK6040 motor

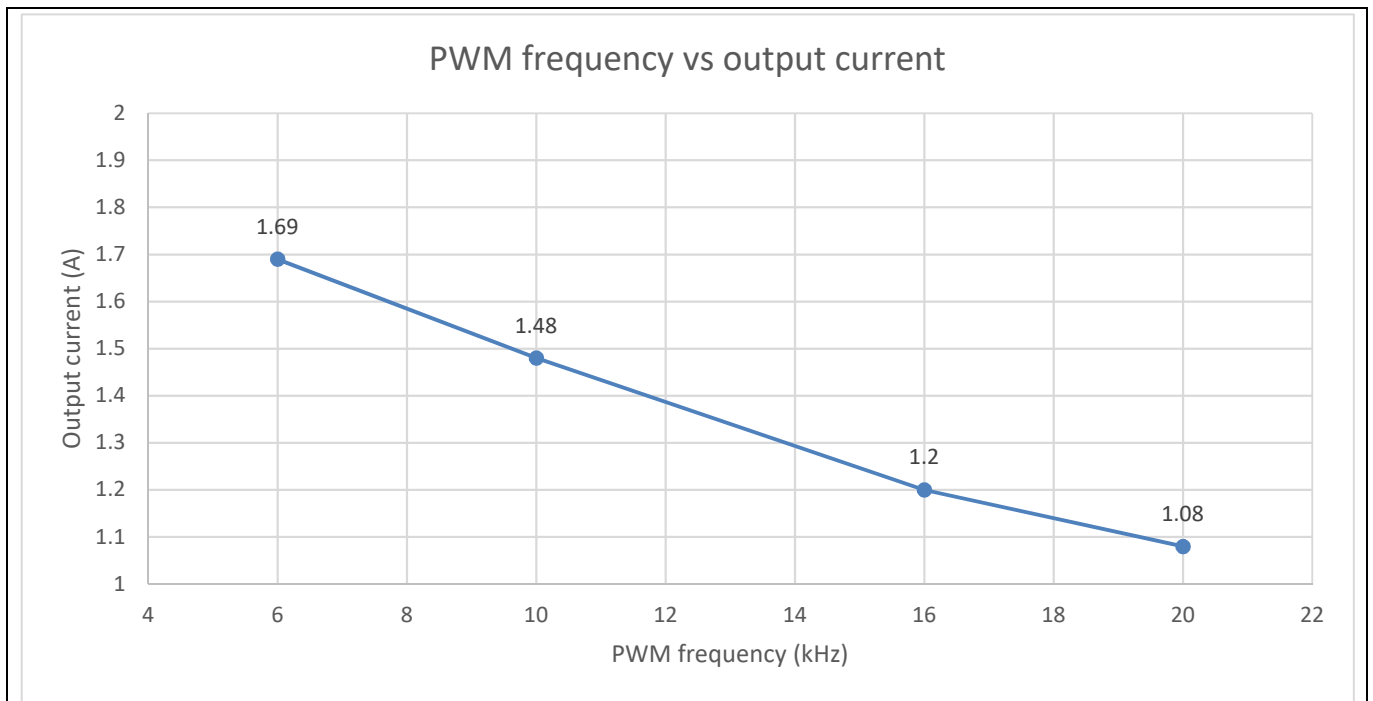

Figure 23 Output ability at different PWM frequency

4.4 Overcurrent protection

Figure 24 displays the overcurrent protection circuitry. The current sensing signal I_Shunt is connected to gatekill (GK) via the comparator U6A. If the motor peak current is larger than the setting value I_{OCp} for more than I_{OCp} input filter time, the RFE will be triggered low, which means that the GK signal is active.

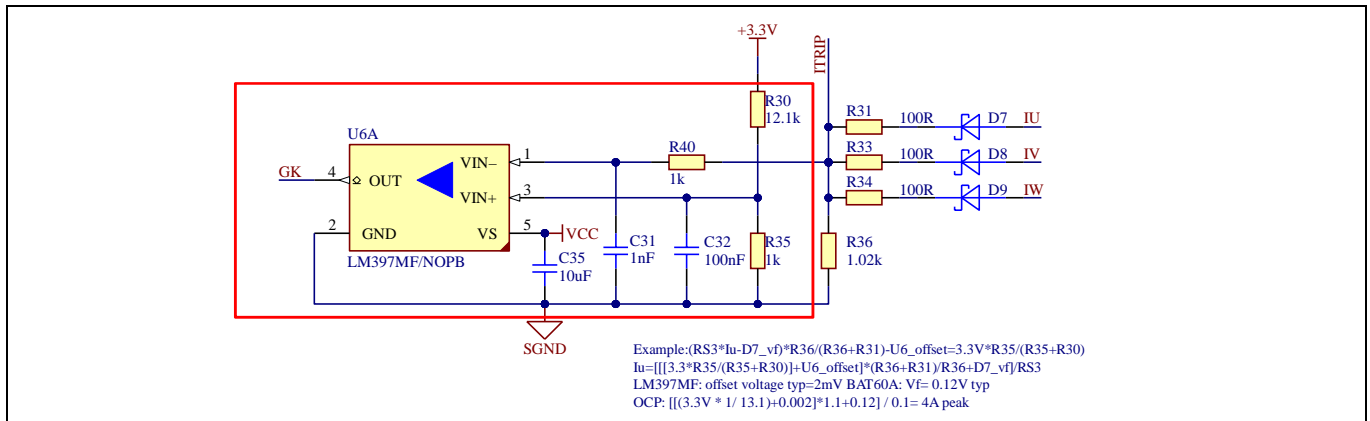

Figure 24 IPM overcurrent protection and over-temperature protection circuit

The inverter output peak current is about 4 A_{peak}.

$$I_{OCp} = \frac{VDD \cdot \frac{R35}{R30 + R35} + Voffset}{RSHUNT} \cdot \frac{R36 + R31}{R36} + VD7$$

For iMOTION™ IMC1xx control IC, there are three types of Gatekill input sources (as shown in Figure 25). For the input source configured as “Gatekill-Pin” or “Both”, the iMOTION™ control IC will stop the motor when the GateKill signal is active.

But please note that if the comparator for the Gatekill input source is selected, the external Gatekill signal will not be used. And the current-sensing signal I_Shunt will be compared by the internal comparator with the “Gatekill Comparator Reference” value only set in MCEWizard.

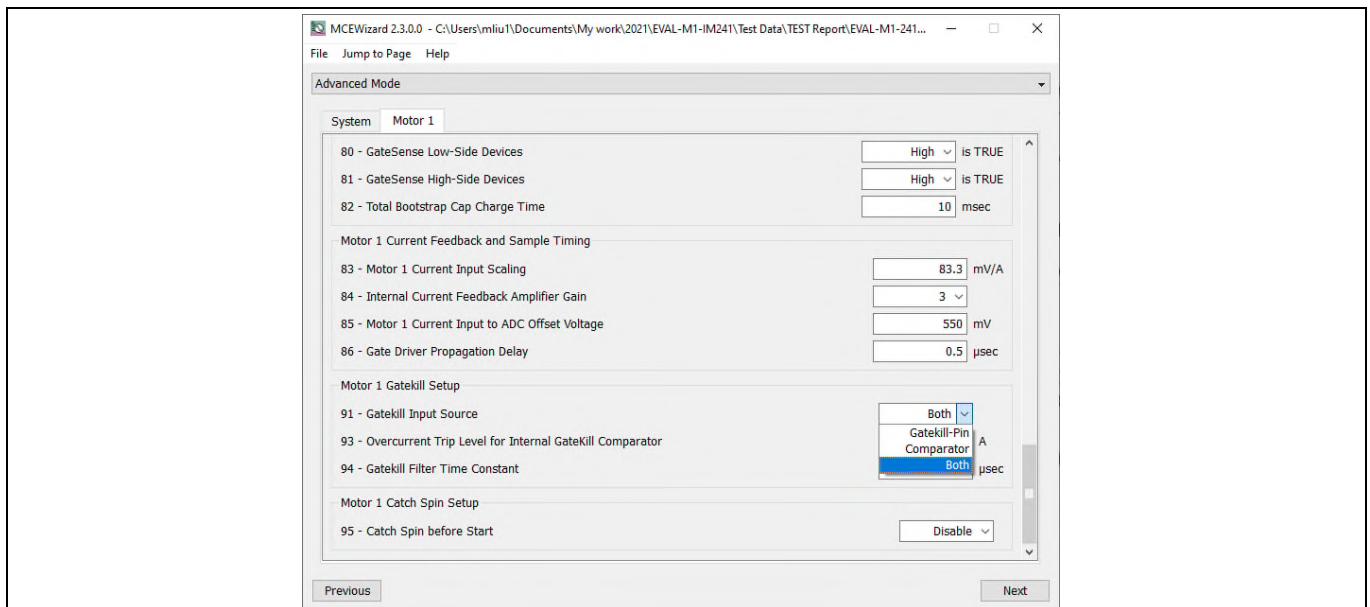

Figure 25 Gatekill configuration in MCEWizard for EVAL-M1-101T

System performance

The signal response of this overcurrent protection circuit is shown in Figure 26.

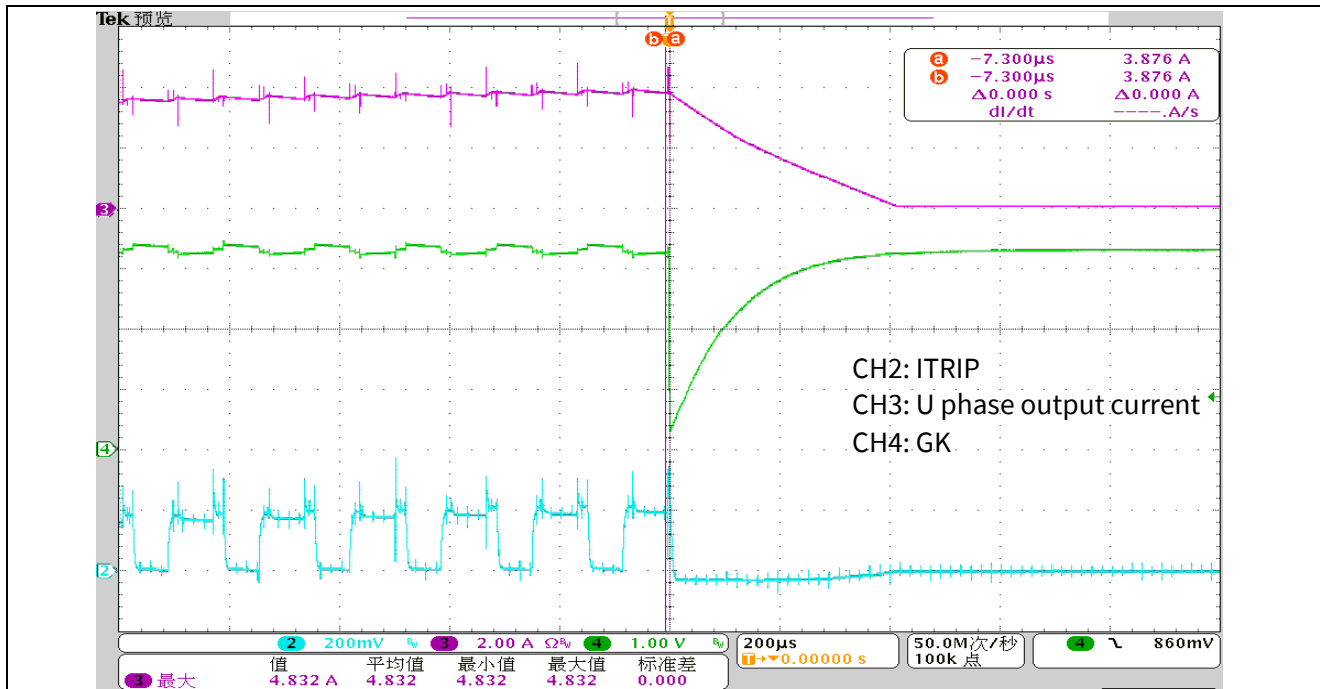

Figure 26 Overcurrent protection response waveform

4.5 Short circuit protection

Figure 27 displays the short circuit protection circuitry. The module’s ITRIP pin is used as a short circuit protection function, and the filtering time is designed to be 2.2 us. The response time waveform of ITRIP is shown in Figure 28, which is taken from the datasheet of IM241.

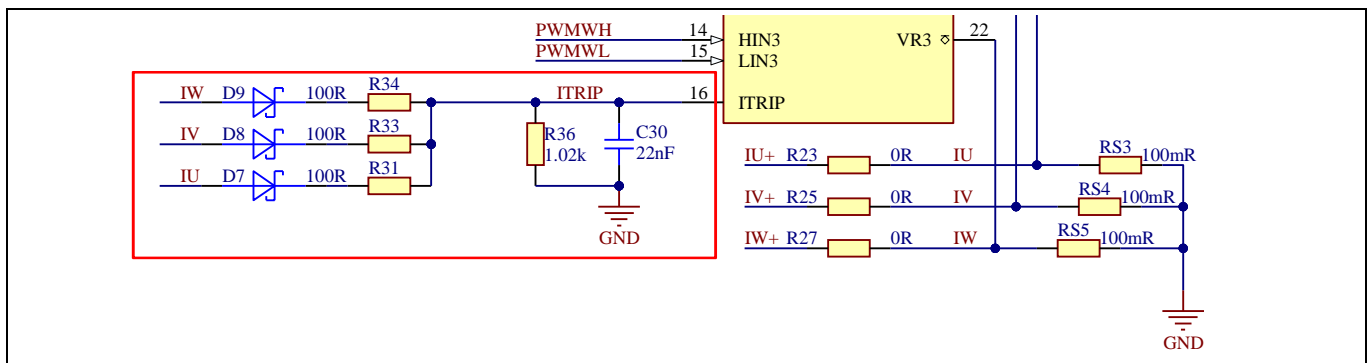

Figure 27 Short circuit protection

System performance

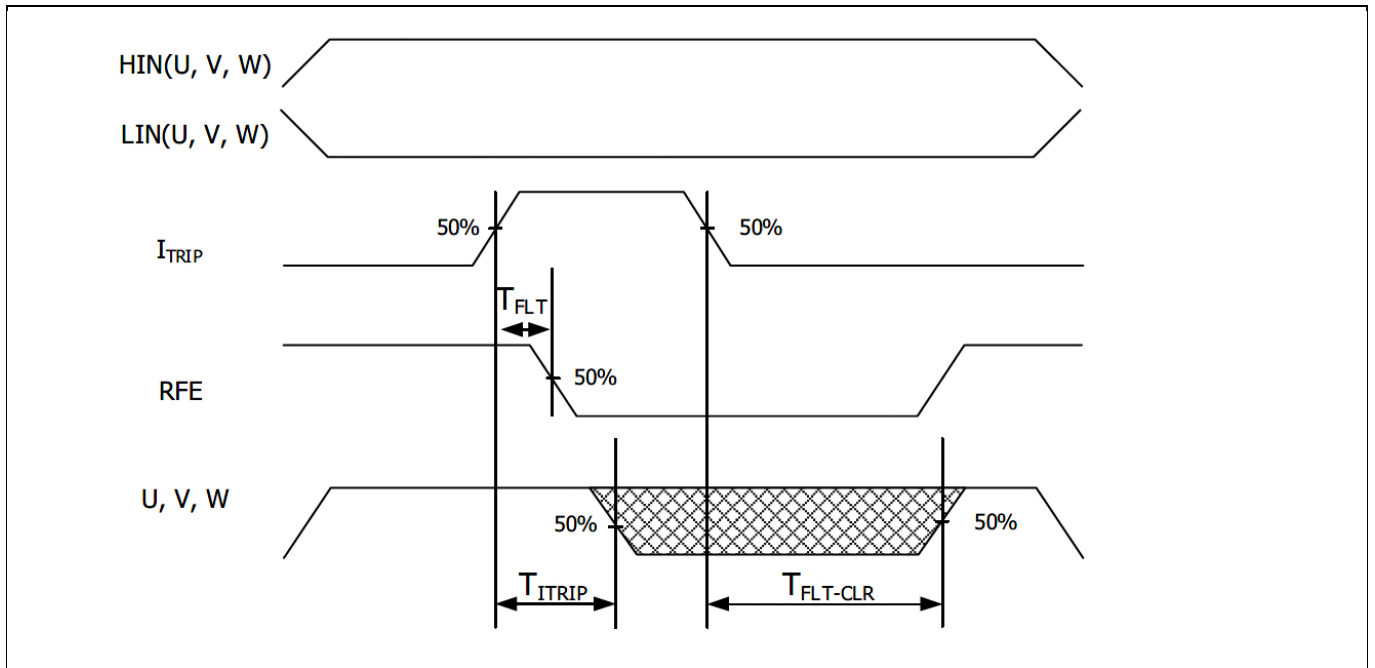

Figure 28 ITRIP time waveform

Please refer to Figure 29, Figure 30 and Figure 31 for actual test waveforms.

The test results are as follows:

- $T_{FLT}=850\text{ ns}$
- $T_{ITRIP}=1.44\text{ }\mu\text{s}$
- $T_{FLT-CLR}=62.6\text{ }\mu\text{s}$

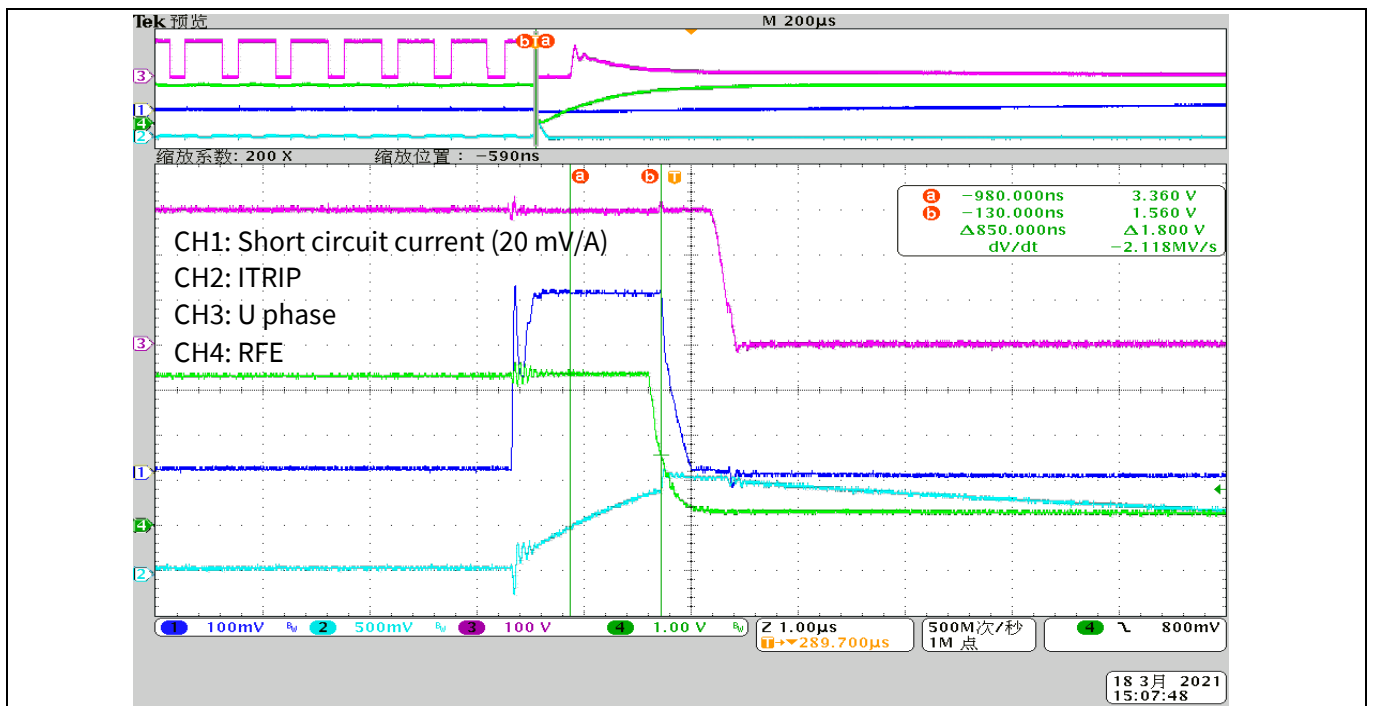

Figure 29 T_{FLT} waveform

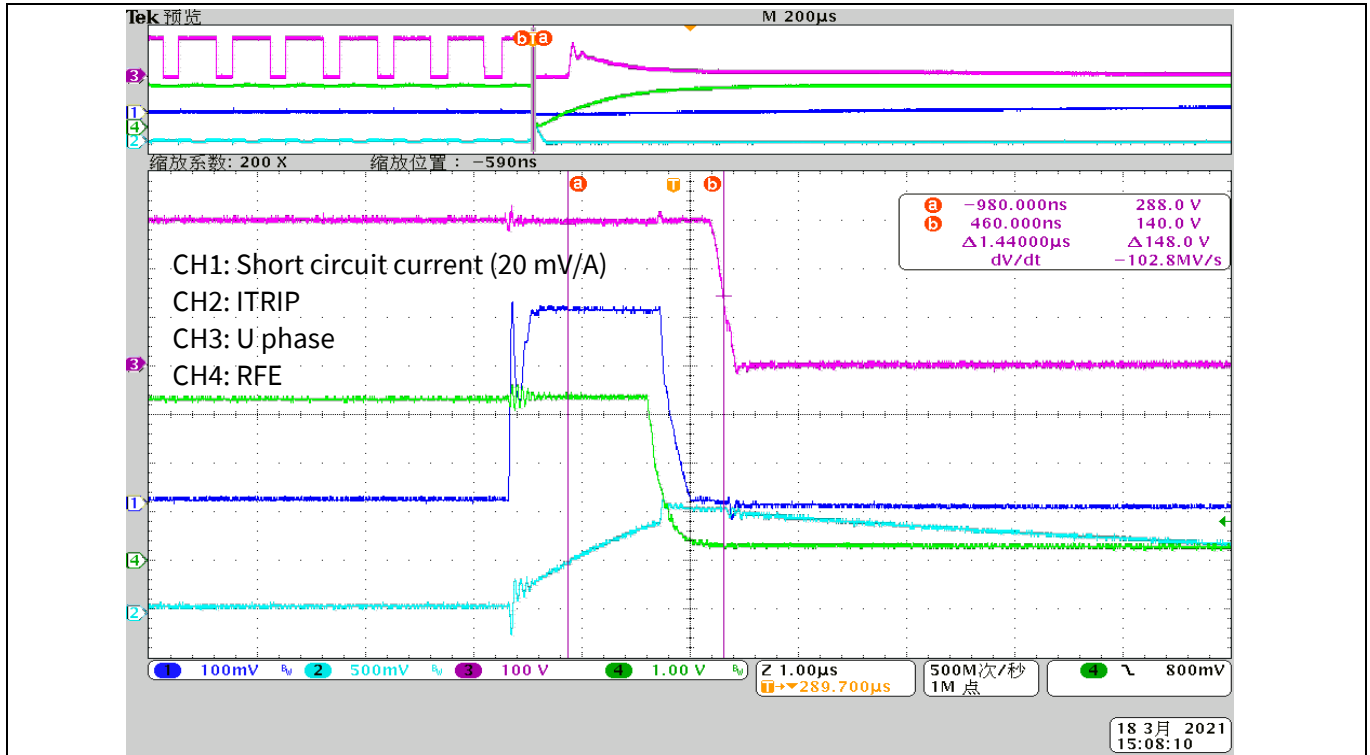

Figure 30 T_{ITRIP} waveform

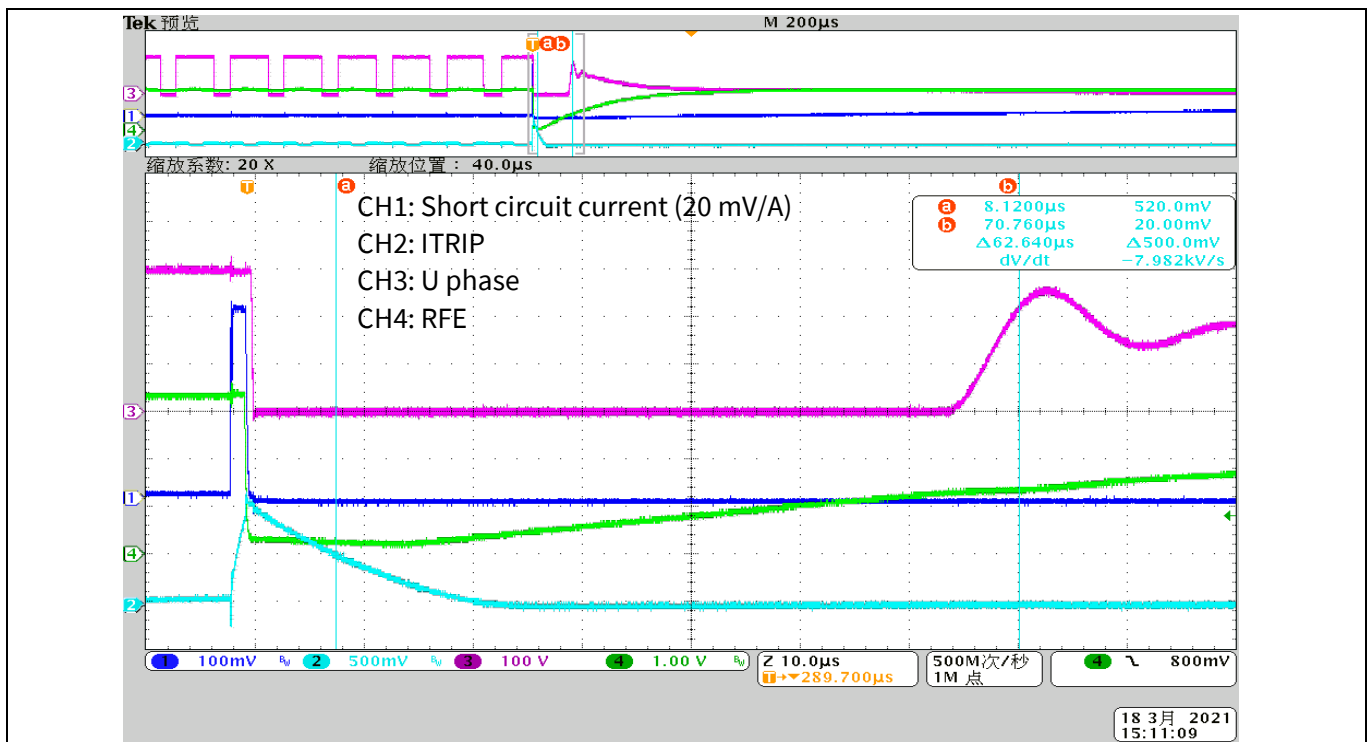

Figure 31 $T_{FLT-CLR}$ waveform

System performance

4.6 EMI test results

Figure 32, Figure 33 and Figure 34 shows the EMI performance at different load, which are performed under the following conditions:

- 10 kHz PWM, three-phase modulation
- GK6040 motor
- The three types of load are 0.28 A (20%), 0.7 A (50%), 1.4 A (100%)
- Pass EN55032 standard and more than 3 dB margin

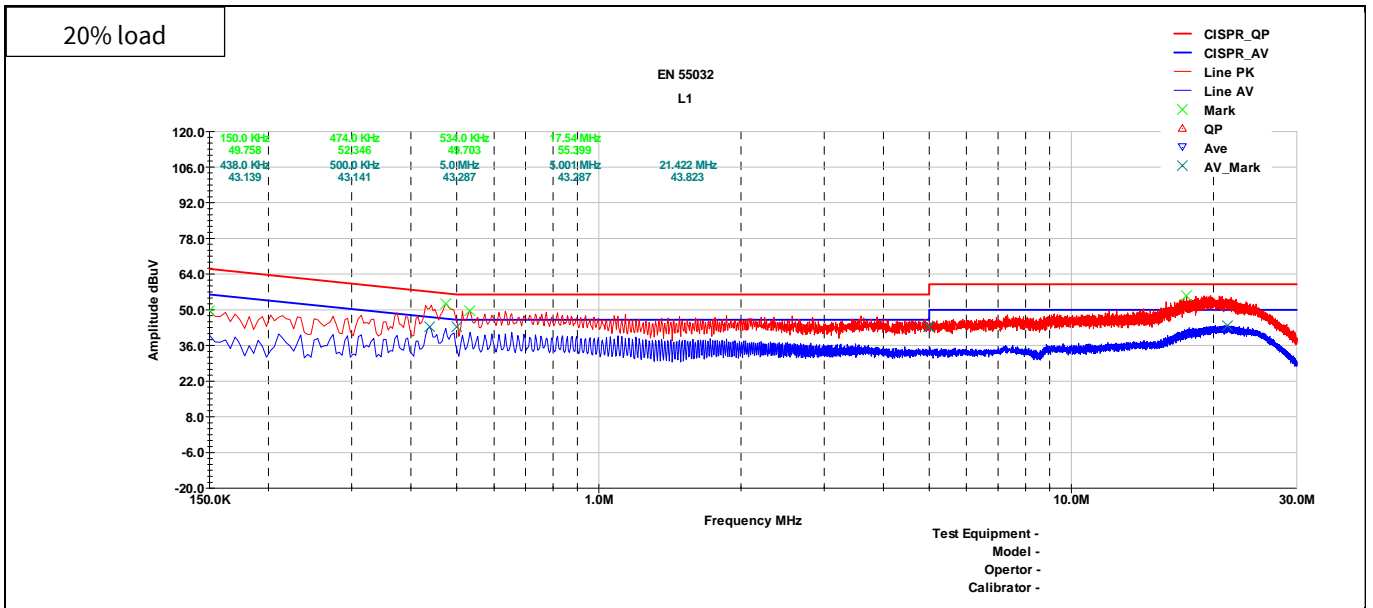

Figure 32 EMI test waveform at 20% load

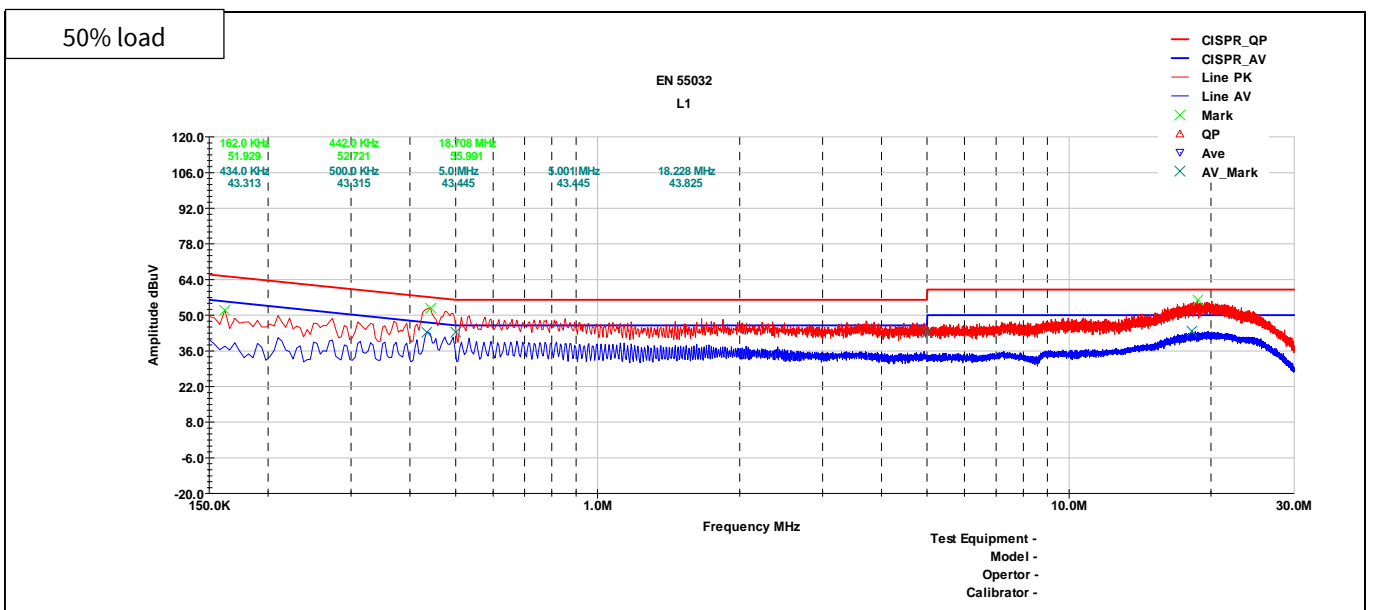

Figure 33 EMI test waveform at 50% load

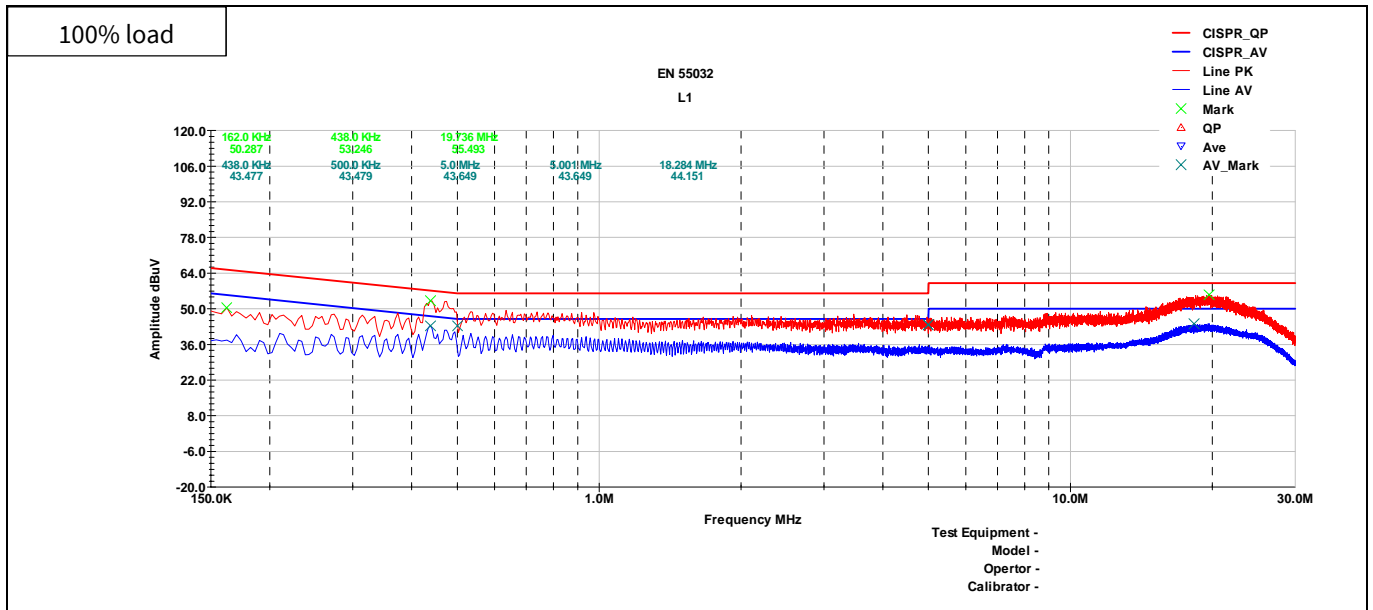

Figure 34 EMI test waveform at 100% load

5 References and appendices

5.1 Abbreviations and definitions

Table 8 Abbreviations

Abbreviation	Meaning
CE	Conformité Européenne
EMI	Electromagnetic interference
UL	Underwriters Laboratories
GK	Gate kill

5.2 References

- [1] Infineon Technologies AG. Datasheet of Infineon IM241-L6T2B (2021). V1.0 www.infineon.com
- [2] Infineon Technologies AG. Datasheet of Infineon IMC101T-T038 (2019). V1.4 www.infineon.com
- [3] Infineon Technologies AG. MCEWizard_V2.3.0.0 User Guide (2019) www.infineon.com
- [4] Infineon Technologies AG. MCEDesigner_V2.3.0.0 Application Guide (2019) www.infineon.com
- [5] Infineon Technologies AG. iMOTION™ Motion Control Engine Software Reference Manual (2020) V1.3 www.infineon.com

5.3 Ordering details and other information

The power board is now available for customers in small order quantities. In order to initiate the testing, customers are advised to order the following items:

Base Part Number	Package	Standard Pack		Orderable Part Number
		Form	Quantity	
EVAL-M1-IM241	EVAL	Boxed	1	EVALM1IM241TOBO1
ICE54780AG	PG-DSO-12	TAPE&REEL	2500	ICE5GR4780AGXUMA1
IM241-L6T2B	DIP 29x12			

Revision history

Revision history

Document version	Date of release	Description of changes
V0.1	2021-03-12	First draft

Trademarks

All referenced product or service names and trademarks are the property of their respective owners.

Edition 2021-03-19

Published by

Infineon Technologies AG

81726 Munich, Germany

© 2021 Infineon Technologies AG.

All Rights Reserved.

Do you have a question about this document?

Email: erratum@infineon.com

Document reference

UG-2021-01

For further information on the product, technology, delivery terms and conditions and prices please contact your nearest Infineon Technologies office (www.infineon.com).

WARNINGS

Due to technical requirements products may contain dangerous substances. For information on the types in question please contact your nearest Infineon Technologies office.

Except as otherwise explicitly approved by Infineon Technologies in a written document signed by authorized representatives of Infineon Technologies, Infineon Technologies' products may not be used in any applications where a failure of the product or any consequences of the use thereof can reasonably be expected to result in personal injury.

X-ON Electronics

Largest Supplier of Electrical and Electronic Components

Click to view similar products for [Power Management IC Development Tools](#) category:

Click to view products by [Infineon](#) manufacturer:

Other Similar products are found below :

[EVB-EP5348UI](#) [ISLUSBI2CKIT1Z](#) [ISL2109012EV1Z](#) [ISL8002AEVAL1Z](#) [ISL91108IIA-EVZ](#) [DCD48AP480T320A50](#)
[NCP10671B05GEVB](#) [AP62250WU-EVM](#) [AP61102Z6-EVM](#) [AP63300WU-EVM](#) [AP61100Z6-EVM](#) [AP62300Z6-EVM](#) [BTS71033-6ESA](#)
[EV13N91A](#) [EV55W64A](#) [Si8285_86v2-KIT](#) [AP33772S-EVB](#) [EVALM7HVIGBTFCINV4TOBO1](#) [ROA1286023/1](#)
[REFSHA35IMD111TSYSTOBO1](#) [150037482](#) [TDINV3000W50B-KIT](#) [NCP1681CCM1KWGEVB](#) [SI83401BAA-KIT](#) [SI83402BAA-KIT](#)
[SI83411BAA-KIT](#) [SI83412BAA-KIT](#) [MIKROE-5294](#) [MIKROE-5451](#) [MIKROE-5374](#) [APEK49406GES-01-T](#) [EVB81332](#) [AP61300QZ6-](#)
[EVM](#) [MIKROE-5019](#) [BTG70902EPLDAUGHBRDTOBO1](#) [5650](#) [TAB-48017](#) [APEK89307KET-01-T](#) [MIKROE-5510](#) [64010](#)
[PAM2423AECADJ-EVM](#) [EVAL6EDL04I065PRTOBO1](#) [LT8648SJV#WPBF](#) [LT8648SEV#WPBF](#) [EVB81340-100W](#)
[RTKA489EPRDK0010BU](#) [DC3107A](#) [EVL4248-QV-00A](#) [EVQ4371-V-1000-00A](#) [EVL28167-B-Q-00A](#)