

PROFET™ Wire Guard smart power high-side switch

Features

- High-side switch with diagnosis and embedded protection
- Selectable integrated I2t function for wire harness protection
- Operating current < 60 μ A for active supply in key-off mode
- IDL pin for microcontroller wake-up in idle mode
- Adjustable overcurrent threshold
- Capacitive load switching mode
- Sequential diagnosis for status readout
- Reverse ON for low power dissipation in reverse polarity
- Switch-on capability while inverse current condition (Inverse ON)

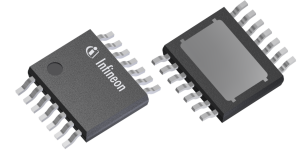

Potential applications

- Replaces electromechanical relays, fuses and discrete circuits
- Protection of wire harness and system supply
- Main switch for ECU power supplies
- Switch for active power supplies in key-off mode
- Suitable for resistive, inductive and capacitive loads up to 6.8 A

Product validation

Qualified for automotive applications. Product validation according to AEC-Q100 Grade 1.

Description

The device is a smart power high-side switch, providing enhanced protection and diagnosis functions. Besides standard device protection functions it offers a selectable I2t protection, an adjustable overcurrent protection, an idle mode as well as a sequential diagnosis mode via IS pin.

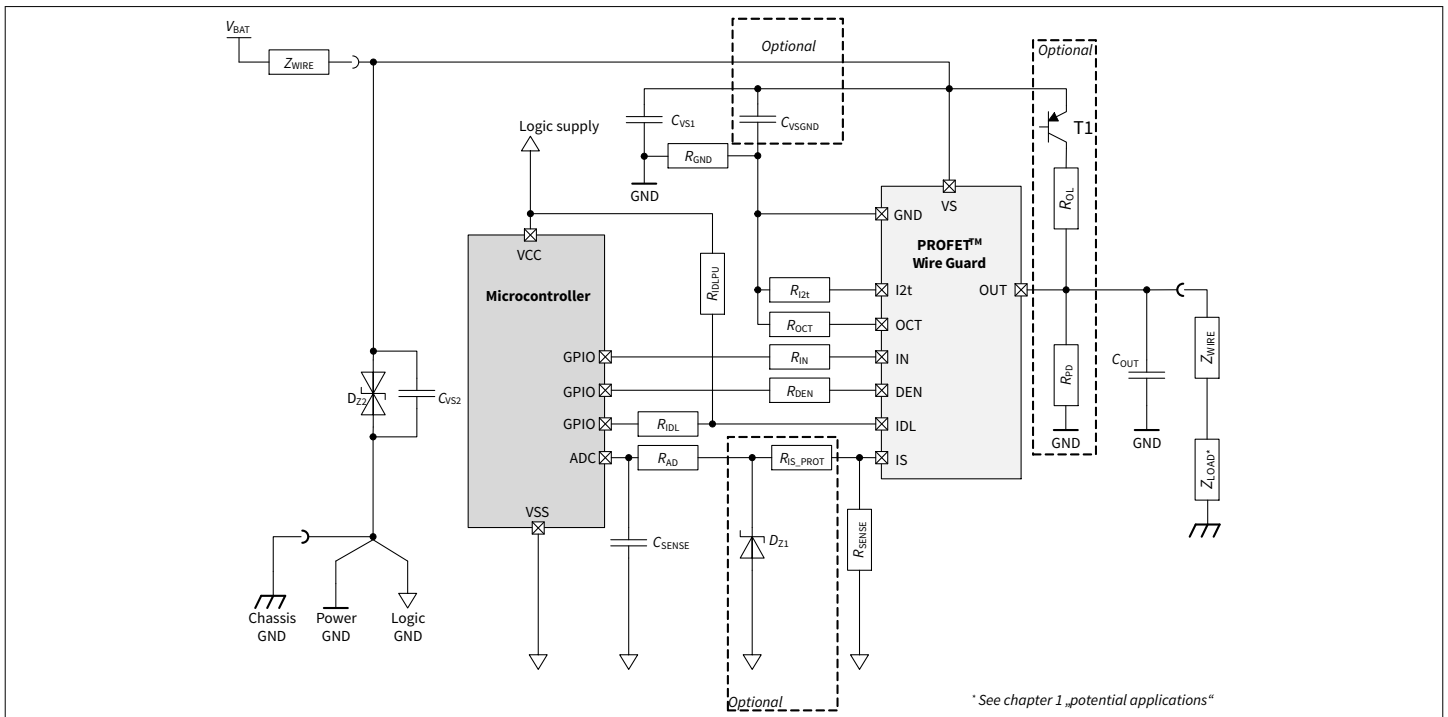

Product type	Package	Marking
BTG7016A-1EPW	PG-TSDSO-14	7016A1W

Table of contents

	Table of contents	2
1	Product description	5
1.1	Product summary	5
1.2	Further features	5
2	Block diagram and terms	6
2.1	Block diagram	6
2.2	Terms	6
3	Pin configuration	7
3.1	Pin assignment	7
3.2	Pin definitions and functions	7
4	General product characteristics	9
4.1	Absolute maximum ratings	9
4.2	Functional range	12
4.3	Thermal resistance	12
4.4	PCB setup	13
4.5	Thermal impedance	14
5	Logic pins	15
5.1	Latched input pin (IN)	15
5.2	Diagnosis pin (DEN)	16
5.3	I2t selection pin (I2t)	17
5.4	Overcurrent threshold pin (OCT)	18
5.5	Idle mode pin (IDL)	19
5.6	Electrical characteristics logic pins	19
6	Power supply	22
6.1	Operation modes	22
6.1.1	Unsupplied	24
6.1.2	Power-up	24
6.1.3	Sleep mode	24
6.1.4	I2t mode	24
6.1.5	Inactive with diagnosis mode	24
6.1.6	I2t with diagnosis mode	24
6.1.7	Idle mode	25
6.1.8	Active with diagnosis	25
6.1.9	CLS mode	25
6.1.10	CLS with diagnosis mode	25
6.1.11	Inactive mode	25
6.1.12	Fault mode	25
6.2	Undervoltage on VS	26

6.3	Electrical characteristics power supply	26
6.3.1	Electrical characteristics - power supply	27
7	Power stages	29
7.1	Output ON-state resistance	29
7.2	Switching loads	29
7.2.1	Switching resistive loads	29
7.2.2	Switching inductive loads	30
7.2.3	Capacitive load switching	31
7.3	Advanced switching characteristics	32
7.3.1	Inverse current behavior	32
7.4	Electrical characteristics power stages	34
8	Device protection	38
8.1	Overtemperature protection	38
8.2	Overcurrent threshold protection	39
8.3	Device protection and diagnosis in case of fault	42
8.3.1	Intelligent latch reset strategy after device protection triggered	42
8.4	Additional protections	45
8.4.1	Reverse polarity protection	45
8.4.2	Overvoltage protection	45
8.5	Protection against loss of connection	45
8.5.1	Loss of battery and loss of load	45
8.5.2	Loss of ground	46
8.6	Electrical characteristics device protection	46
9	System protection	49
9.1	I2t protection	49
9.1.1	I2t protection and idle mode	51
9.1.2	Intelligent latch reset strategy after I2t protection triggered	51
9.2	Electrical characteristics protection	54
10	Diagnosis	56
10.1	Sequential diagnosis	58
10.1.1	Current sense (address #1 - IN=high)	61
10.1.2	Open load in OFF (address #1 - IN = low)	63
10.1.3	I2t setting (address #2 - IN = x)	64
10.1.4	I2t status (address #3 - IN = x)	65
10.1.5	OCT setting (address #4 - IN = x)	65
10.1.6	Digital current sense (address #5 - IN = high)	66
10.1.7	Sense verification current (address #5 - IN = low)	67
10.2	SENSE timings	67
10.3	Electrical characteristics diagnosis	68
10.3.1	Electrical characteristics diagnosis - power output stages	72

11	Application information	76
11.1	Application setup	76
11.2	External components	76
11.3	Further application information	77
12	Package outlines	78
13	Revision history	80
	Disclaimer	81

1 Product description

1.1 Product summary

Table 1 Product summary

Parameter	Symbol	Values
Minimum operating voltage	$V_{S(OP)}$	4.1 V
Minimum operating voltage (cranking)	$V_{S(UV)}$	2.75 V
Maximum operating voltage	V_S	28 V
Minimum overvoltage protection ($T_J = 25^\circ\text{C}$)	$V_{DS(CLAMP)_25}$	35 V
Maximum current in sleep mode ($T_J \leq 85^\circ\text{C}$)	$I_{VS(SLEEP)_85}$	0.2 μA
Operating current in idle mode (channel ON)	$I_{GND(IDLE)}$	60 μA
Maximum operating current	$I_{GND(I2t_D)}$	7.4 mA
Typical ON-state resistance ($T_J = 25^\circ\text{C}$)	$R_{DS(ON)_25}$	18 m Ω
Maximum ON-state resistance ($T_J = 150^\circ\text{C}$)	$R_{DS(ON)_150}$	33 m Ω
Nominal load current ($T_A = 85^\circ\text{C}$)	$I_{L(NOM)_85}$	6.8 A
Highest configurable overcurrent detection threshold ($T_J = -40^\circ\text{C}$, $I_{OCT} = 50 \mu\text{A}$)	$I_{L(HOCT)_40}$	36 A
Typical current sense ratio at $I_L = I_{L(NOM)_85}$	k_{ILIS}	6900

1.2 Further features

Further features are named in detail as follows:

- Green product (RoHS compliant)
- Proportional load current sense
- Open load in ON and OFF state
- Short circuit protection to ground and battery
- Readout of I2t and overcurrent protection settings
- Readout of wire harness protection status
- Absolute and dynamic temperature limitation with intelligent latch
- Adjustable overcurrent protection (tripping) with intelligent latch
- Selectable I2t function for wire harness protection with intelligent latch
- Undervoltage shutdown
- Overvoltage protection with external components

2 Block diagram and terms

2.1 Block diagram

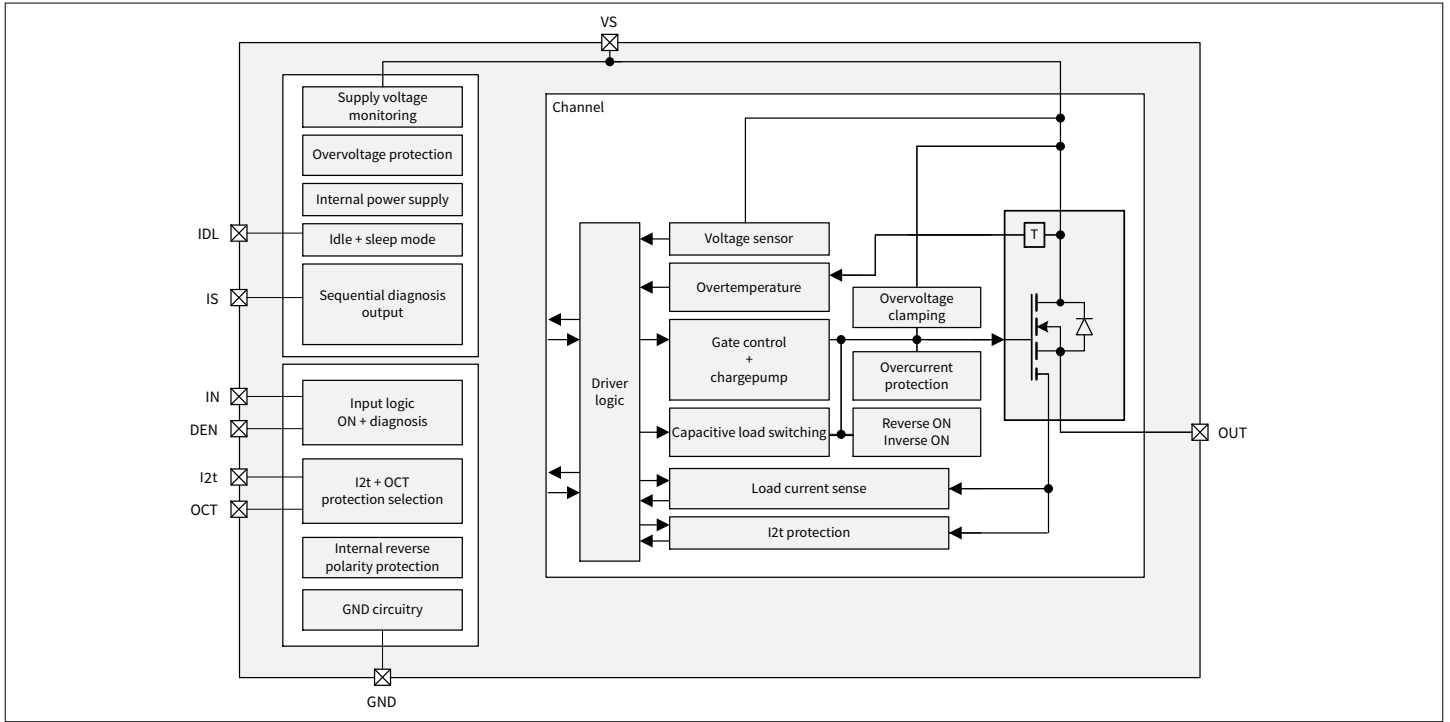

Figure 1 Block diagram

2.2 Terms

Figure 2 shows all terms used in this datasheet, with associated convention for positive values.

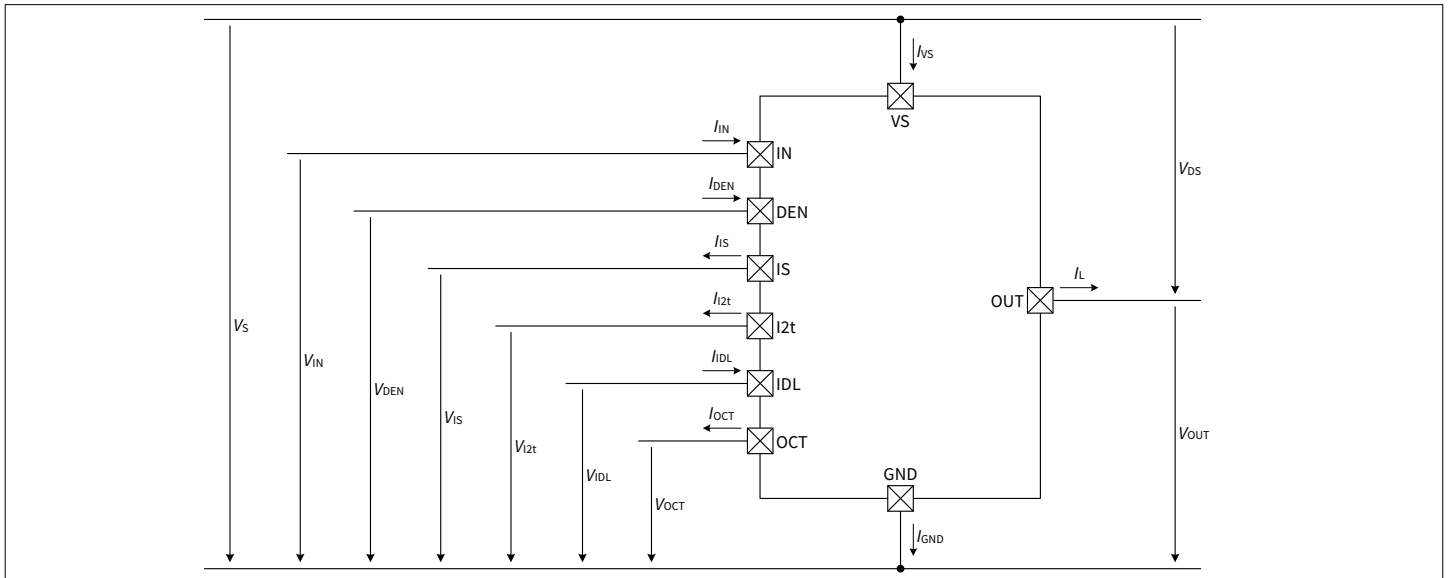

Figure 2 Voltage and current convention

3 Pin configuration

3.1 Pin assignment

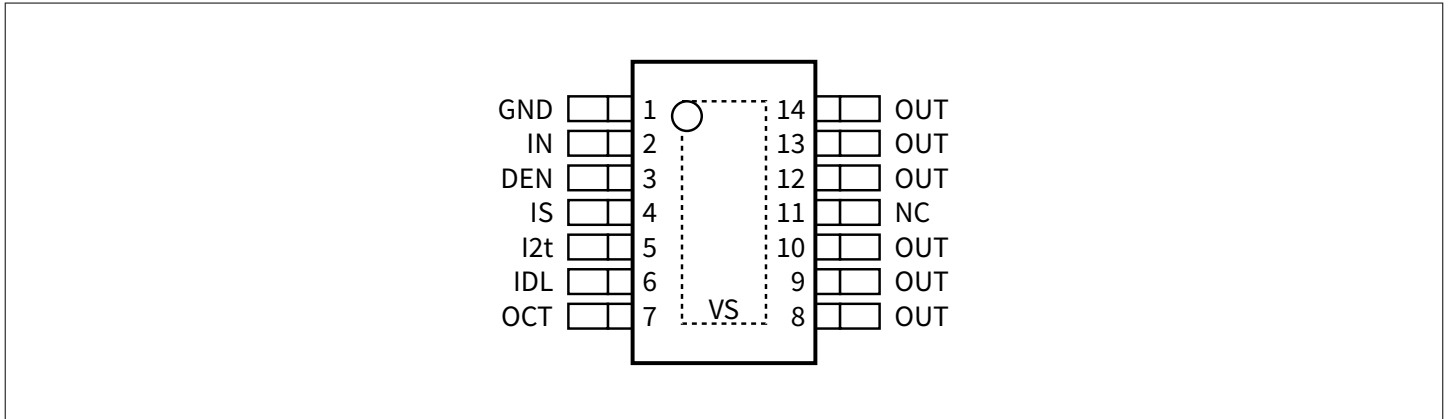

Figure 3 Pin configuration

3.2 Pin definitions and functions

Pin	Symbol	Function
EP	VS (exposed pad)	Supply voltage Battery voltage.
1	GND	Ground Ground connection for the internal logic.
2	IN	Input channel Digital signal to switch ON the channel ("high" active). If not used: connect with a 10 kΩ resistor either to GND pin or to module ground.
3	DEN	Diagnostic enable Digital signal to enable device diagnosis ("high" active) and to clear the protection latch of channel. If not used: connect with a 10 kΩ resistor either to GND pin or to module ground.
4	IS	SENSE current output Analog/digital signal for diagnosis. If not used: left open.
5	I2t	Selectable I2t protection curve A resistor R_{I2t} needs to be connected between I2t pin and GND pin to select one of the available I2t protection curves. If not used: left open. Curve selection as described in Chapter 9.1 .
6	IDL	Idle mode open drain output Digital signal to inform / wake-up the microcontroller in case of idle mode ("high impedance" in idle/sleep mode; "low" in all other modes). If not used: left open.

3 Pin configuration

Pin	Symbol	Function
7	OCT	Adjustable overcurrent threshold A resistor R_{OCT} needs to be connected between OCT pin and GND pin to adjust the overcurrent threshold. If not used: left open. Threshold selection as described in Figure 27 .
11	NC	Not connected, internally not bonded.
8-10, 12-14	OUT	Output Protected high-side power output channel ¹⁾ .

1) All output pins of the channel must be connected together on the PCB. All pins of the output are internally connected together. PCB traces have to be designed to withstand the maximum current which can flow.

4 General product characteristics

4.1 Absolute maximum ratings

Table 2 Absolute maximum ratings

$T_J = -40^\circ\text{C}$ to $+150^\circ\text{C}$; all voltages and currents according to the voltage and current conventions, specified in [Chapter 2.2](#) (unless otherwise specified)

Parameter	Symbol	Values			Unit	Note or condition	P-Number
		Min.	Typ.	Max.			
Supply pins							
Power supply voltage	V_S	-0.3	–	28	V	¹⁾	PRQ-128
Load dump voltage	$V_{\text{BAT(LD)}}$	–	–	35	V	¹⁾ Suppressed load dump acc. to ISO16750-2 (2012) $R_i = 2 \Omega$	PRQ-130
Supply voltage for short circuit protection	$V_{\text{BAT(SC)}}$	0	–	24	V	¹⁾ Setup acc. to AEC-Q100-012	PRQ-132
Reverse polarity voltage	$V_{\text{BAT(REV)}}$	-18	–	–	V	¹⁾ $t \leq 5 \text{ min}$ $T_A = 25^\circ\text{C}$ Setup as described in Figure 54	PRQ-134
Current through GND pin	I_{GND}	-50	–	50	mA	¹⁾ R_{GND} according to Chapter 11	PRQ-138

Logic & control pins (digital input = DI) DI = IN, DEN

Current through DI pin	I_{DI}	-1	–	2	mA	^{1) 2)}	PRQ-141
Current through DI pin - reverse battery condition	$I_{\text{DI(REV)}}$	-1	–	10	mA	^{1) 2)} $t \leq 5 \text{ min}$	PRQ-142

Analog & control pins (analog input = AI)

AI = I2t, OCT

Current through AI pin	I_{AI}	-2	–	1	mA	^{1) 2)}	PRQ-359
Current through AI pin - reverse battery condition	$I_{\text{AI(REV)}}$	-10	–	1	mA	^{1) 2)} $t \leq 5 \text{ min}$	PRQ-362

(table continues...)

Table 2 (continued) Absolute maximum ratings

$T_J = -40^{\circ}\text{C}$ to $+150^{\circ}\text{C}$; all voltages and currents according to the voltage and current conventions, specified in [Chapter 2.2](#) (unless otherwise specified)

Parameter	Symbol	Values			Unit	Note or condition	P-Number
		Min.	Typ.	Max.			

Logic & control pins (digital output = DO)

DO = IDL

Voltage at DO pin	V_{DO}	-0.3	–	5.5	V	1) 2)	PRQ-828
Current through DO pin	I_{DO}	-1	–	2	mA	1) 2)	PRQ-360
Current through DO pin - reverse battery condition	$I_{DO(REV)}$	-1	–	10	mA	1) 2) $t \leq 5 \text{ min}$	PRQ-361

IS pin

Voltage at IS pin	V_{IS}	-1.5	–	V_S	V	1) $I_{IS} < I_{IS(OFF)}$	PRQ-144
Current through IS pin	I_{IS}	-25	–	$I_{IS(SAT), MAX}$	mA	1)	PRQ-146

Temperatures

Junction temperature	T_J	-40	–	150	$^{\circ}\text{C}$	1)	PRQ-147
Storage temperature	T_{STG}	-55	–	150	$^{\circ}\text{C}$	1)	PRQ-148

ESD robustness

ESD robustness all pins (HBM)	V_{ESD_HBM1}	-2	–	2	kV	1) HBM ³⁾	PRQ-149
ESD robustness OUT vs. GND and VS connected (HBM)	V_{ESD_HBM2}	-4	–	4	kV	1) HBM ³⁾	PRQ-150
ESD robustness all pins (CDM)	V_{ESD_CDM1}	-500	–	500	V	1) CDM ⁴⁾	PRQ-151
ESD robustness corner pins (CDM) - (pins 1, 7, 8, 14)	V_{ESD_CDM2}	-750	–	750	V	1) CDM ⁴⁾	PRQ-152

1) Not subject to production test - specified by design.

2) Maximum VDI/VDO/VAI to be considered for latch-up tests: 5.5 V.

3) Human body model (HBM) robustness according to AEC - Q100-002.

4) Charged device model (CDM) robustness according to AEC - Q100-011 Rev-D; voltage level refers to test condition (TC) mentioned in the standard.

4 General product characteristics

Notes:

1. Stresses above the ones listed here may cause permanent damage to the device. Exposure to absolute maximum rating conditions for extended periods may affect device reliability.
2. Integrated protection functions are designed to prevent IC destruction under fault conditions described in the datasheet. Fault conditions are considered as “outside” normal operating range. Protection functions are not designed for continuous repetitive operation.

Table 3 Absolute maximum ratings - power stages

Parameter	Symbol	Values			Unit	Note or condition	P-Number
		Min.	Typ.	Max.			
Load current	$ I_L $	–	–	$I_{L(HOCT),MAX}$	A	1)	PRQ-157
Maximum energy dissipation - single pulse	E_{AS}	–	–	26	mJ	1) $I_L = 2 \cdot I_{L(NOM),85}$ $T_{J(0)} = 150^\circ\text{C}$ $V_S = 28\text{ V}$	PRQ-958
Maximum energy dissipation - repetitive pulse	E_{AR}	–	–	7.3	mJ	1) $I_L = I_{L(NOM),85}$ $T_{J(0)} = 85^\circ\text{C}$ $V_S = 13.5\text{ V}$ 1M cycles	PRQ-1001

1) Not subject to production test - specified by design.

4.2 Functional range

Table 4 Functional range

$V_S = 5\text{ V to }20\text{ V}$, $T_J = -40^\circ\text{C to }+150^\circ\text{C}$

Unless otherwise specified typical values: $V_S = 13.5\text{ V}$, $T_J = 25^\circ\text{C}$

Typical resistive loads connected to the outputs for testing (unless otherwise specified): $R_L = 2.1\ \Omega$

Parameter	Symbol	Values			Unit	Note or condition	P-Number
		Min.	Typ.	Max.			
Supply voltage range for normal operation	$V_{S(NOR)}$	5	13.5	20	V	1)	PRQ-158
Lower extended supply voltage range for operation (normal)	$V_{S(EXT,LOW)}$	2.75	–	5	V	1) 2) 3) 4) (Parameter deviations possible)	PRQ-159
Upper extended supply voltage range for operation	$V_{S(EXT,UP)}$	20	–	28	V	1) 4) (Parameter deviations possible)	PRQ-160
Junction temperature	T_J	-40	–	150	°C	1)	PRQ-161

1) Not subject to production test - specified by design.

2) In case of V_S voltage decreasing refer to the maximum voltage of $V_{S(UV)}$. In case of V_S voltage increasing refer to the maximum voltage of $V_{S(OP)}$.

3) Calculation of I2t protection curve with $I_L = 0\text{ A}$ for $V_S < 2.75\text{ V}$ (GND resistor voltage drop not included).

4) Device protection functions still operative.

4.3 Thermal resistance

Table 5 Thermal resistance

This thermal data was generated in accordance with JEDEC JESD51 standards. For more information, go to www.jedec.org

Parameter	Symbol	Values			Unit	Note or condition	P-Number
		Min.	Typ.	Max.			
Thermal characterization parameter junction to top	Ψ_{JTOP}	–	3.8	6.4	K/W	1) 2)	PRQ-1003
Thermal resistance junction to case	R_{thJC}	–	3.7	6.3	K/W	1) 2) Simulated at exposed pad	PRQ-1004
Thermal resistance junction to ambient	R_{thJA}	–	34.8	–	K/W	1) 2)	PRQ-1005

1) Not subject to production test - specified by design.

2) According to Jedec JESD51-2,-5,-7 at natural convection on FR4 2s2p board; the product (chip + package) was simulated on a $76.2 \times 114.3 \times 1.5\text{ mm}$ board with 2 inner copper layers ($2 \times 70\ \mu\text{m Cu}$, $2 \times 35\ \mu\text{m Cu}$). Where applicable a thermal via array under the exposed pad contacted the first inner copper layer. Simulation done at $T_A = 105^\circ\text{C}$, $P_{DISSIPATION} = 1\text{ W}$.

4.4 PCB setup

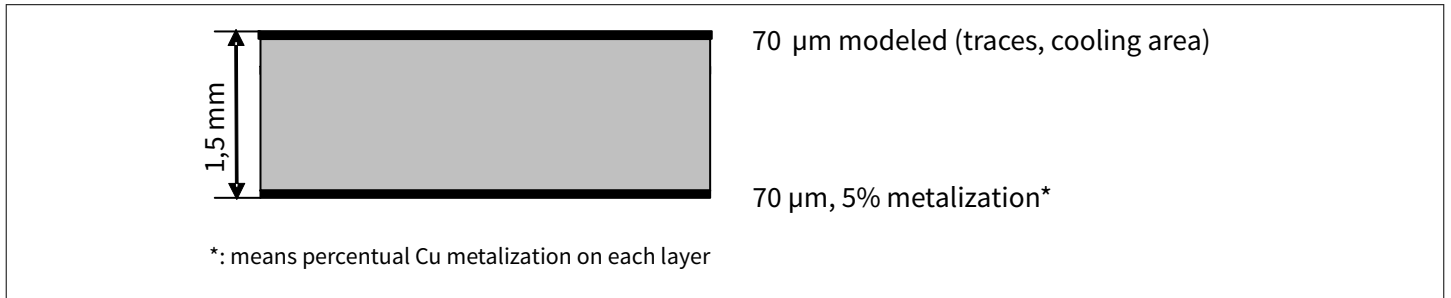

Figure 4 1s0p PCB cross section

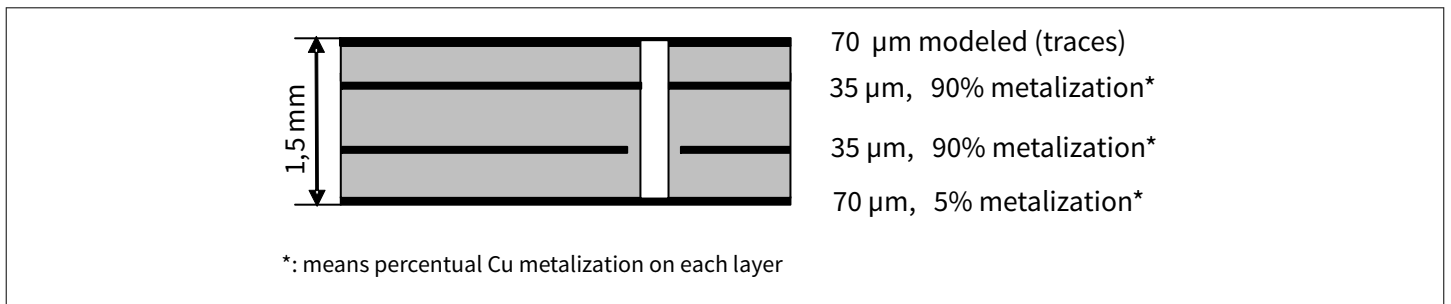

Figure 5 2s2p PCB cross section

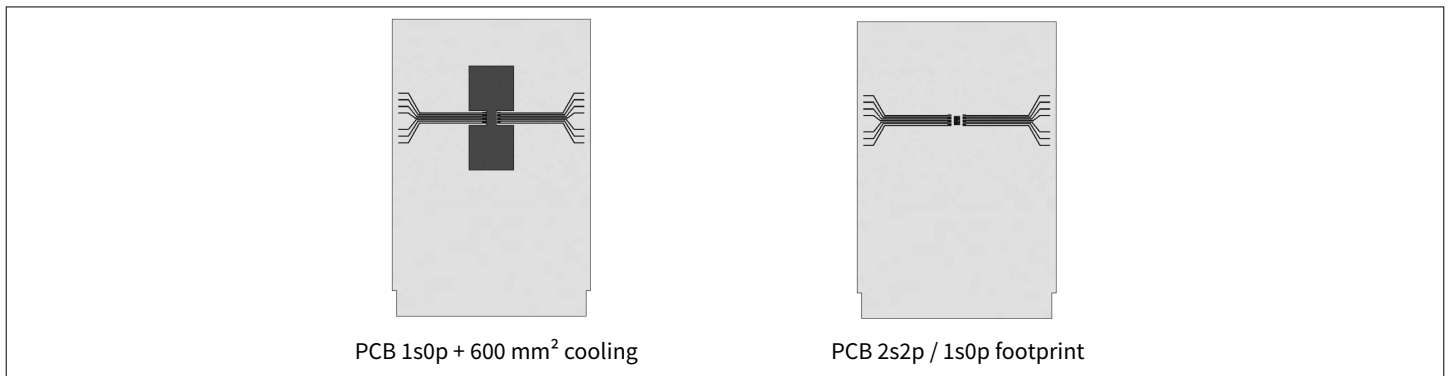

Figure 6 PCB setup for thermal simulations

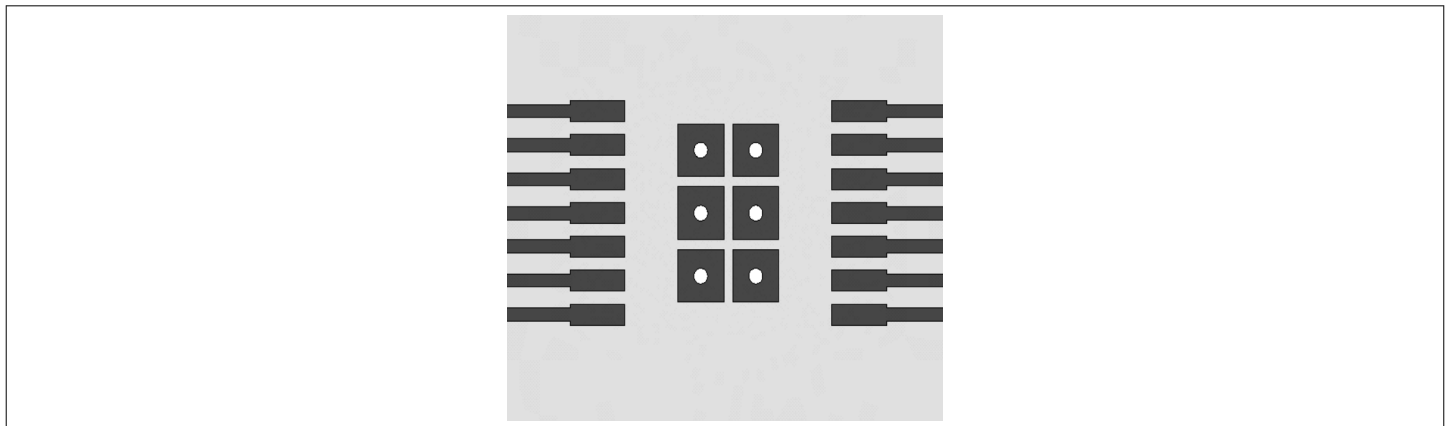

Figure 7 Thermal vias on PCB for 2s2p PCB setup

4.5 Thermal impedance

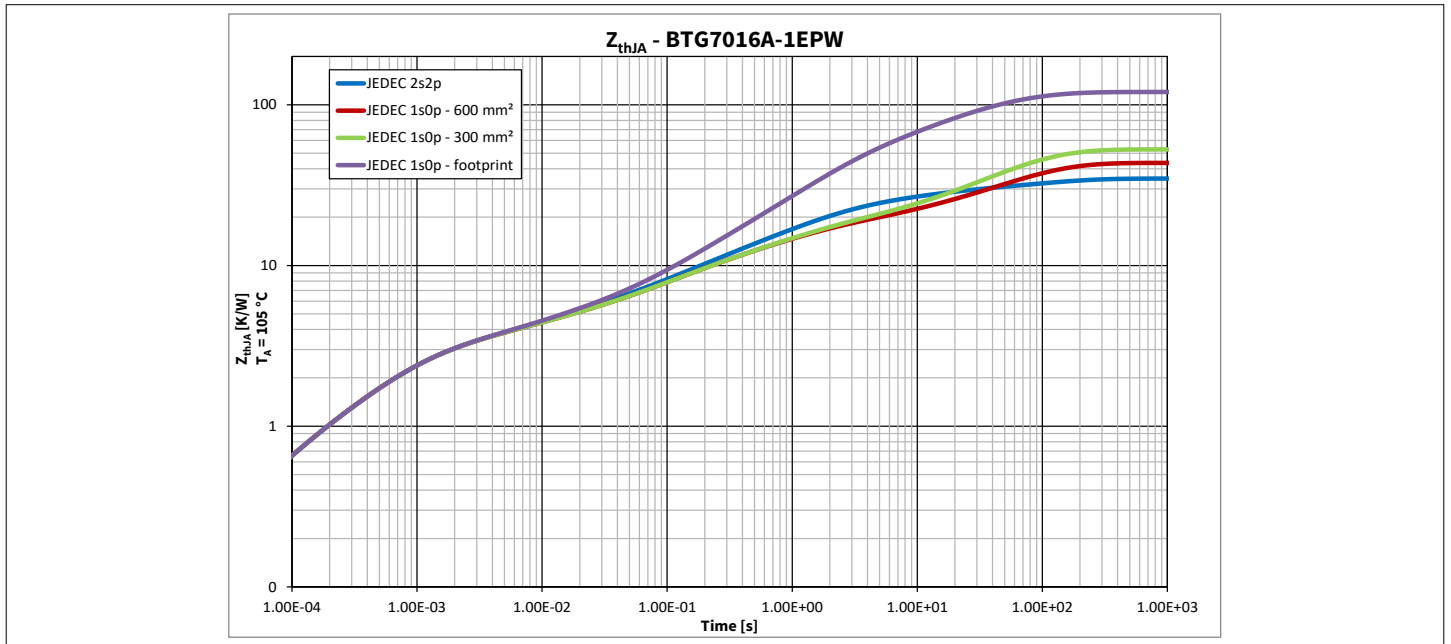

Figure 8 Typical thermal impedance

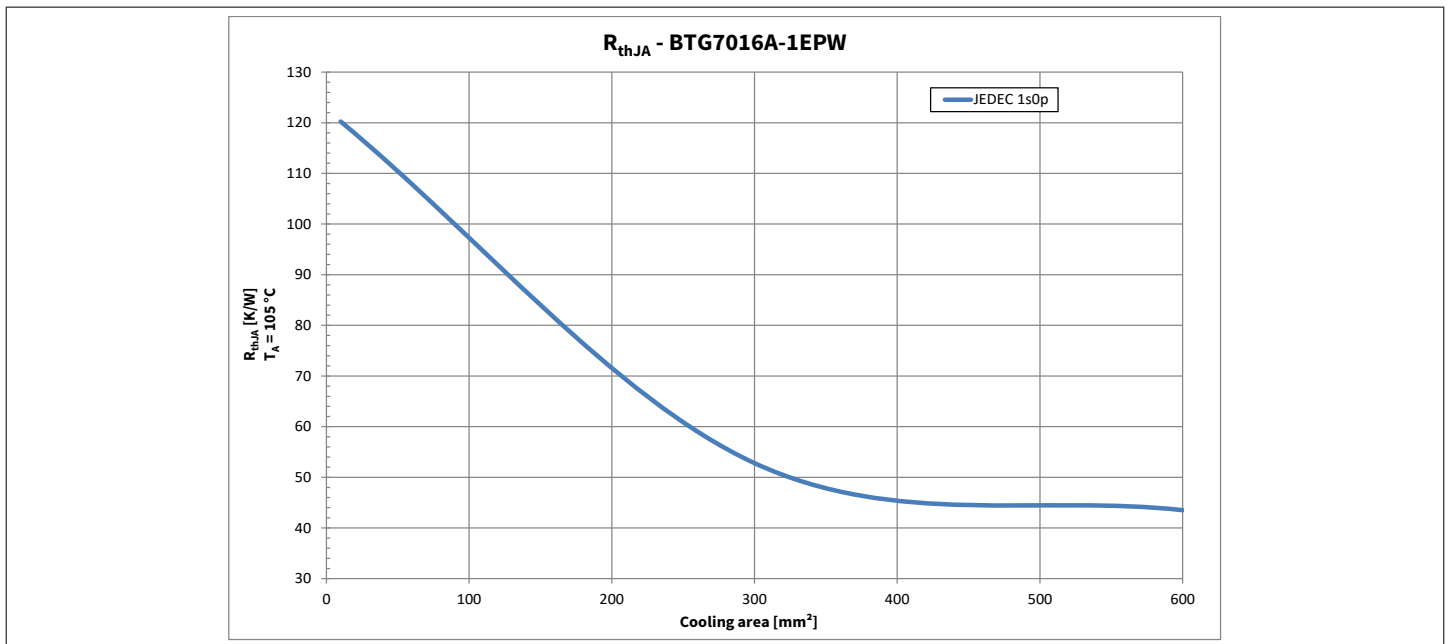

Figure 9 Typical thermal resistance

5 Logic pins

The device has two digital pins: One to control the output stage and the other one to control the diagnosis. Furthermore, there are two analog input pins for either selecting a generic I2t protection curve, or adjusting the overcurrent threshold; one open drain output pin for idle mode indication is available.

5.1 Latched input pin (IN)

The input pin IN activates the output channel. The input circuitry is compatible with 3.3 V and 5 V microcontrollers. The Latched Input feature activates an internal pull up current source in order to keep the input high after it's activation. This feature is deactivated when the DEN pin is set to high. The electrical equivalent of the input circuitry is shown in Figure 10. Indicating the behavior of the digital input current at IN pin $I_{IN(H)}$ by the change of the DEN and IN pin. In case the pin is not used, it must be connected with a 10 kΩ resistor either to GND pin or module ground.

The latched input feature allows the microcontroller to switch the GPIO controlling the IN pin into high impedance, while keeping the mode of the input status unchanged.

The input latch maintains the last mode of the input status as long as:

- Either the IN pin is not actively driven above or below the input thresholds
- The DEN pin is kept low

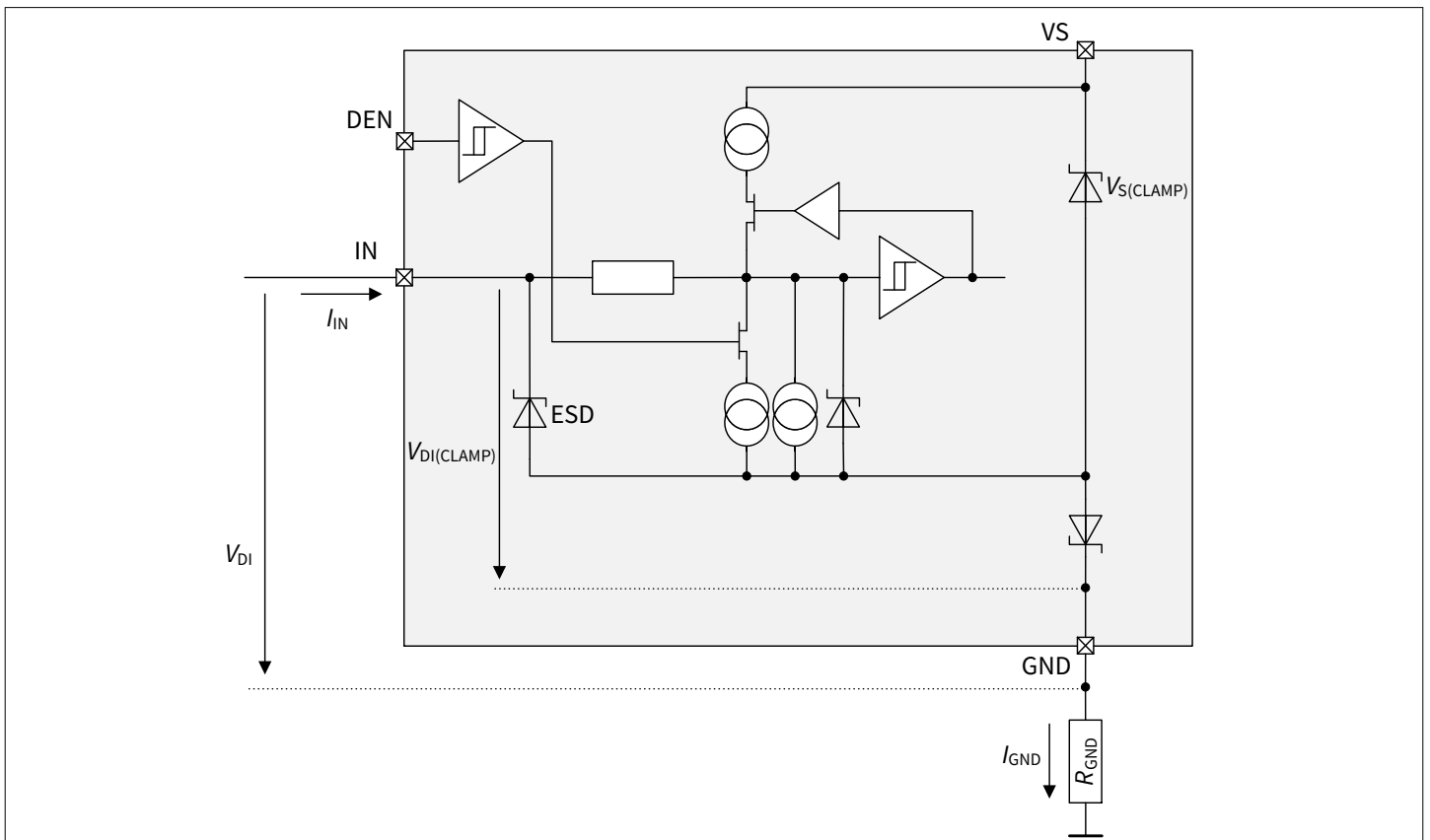

Figure 10 IN pin circuitry

The logic thresholds for “low” and “high” states are defined by parameters $V_{DI(TH)}$ and $V_{IN(HYS)}$. The relationship between these two values is shown in Figure 11. The voltage V_{IN} needed to ensure a “high” state is always higher than the voltage needed to ensure a “low” state.

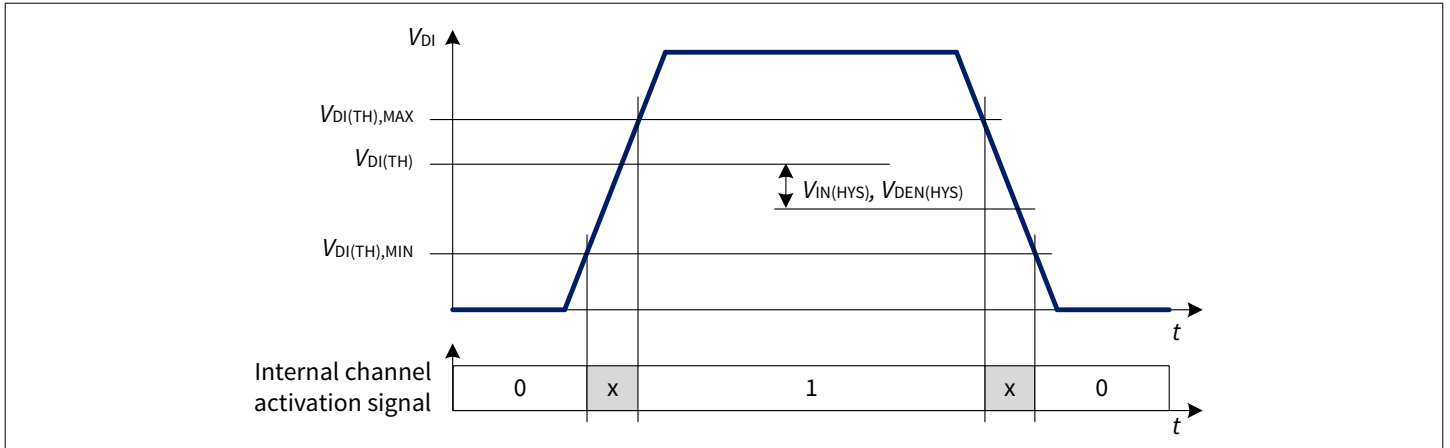

Figure 11 Input threshold voltages and hysteresis

5.2 Diagnosis pin (DEN)

The diagnosis enable (DEN) pin controls the diagnosis circuitry and can be used to reset the latched protection. The protection circuitry is not disabled by the DEN pin. When the DEN pin is set to “high”, the diagnosis is enabled (see [Chapter 10.1.1](#) for more details) as well as the sequential diagnosis by applying a dedicated DEN "low" pulse (see [Figure 42](#) for more details). When it is set to “low”, the diagnosis is disabled and the IS pin is set to high impedance. The latched protection is reset with a dedicated DEN "high" pulse (see [Figure 32](#)).

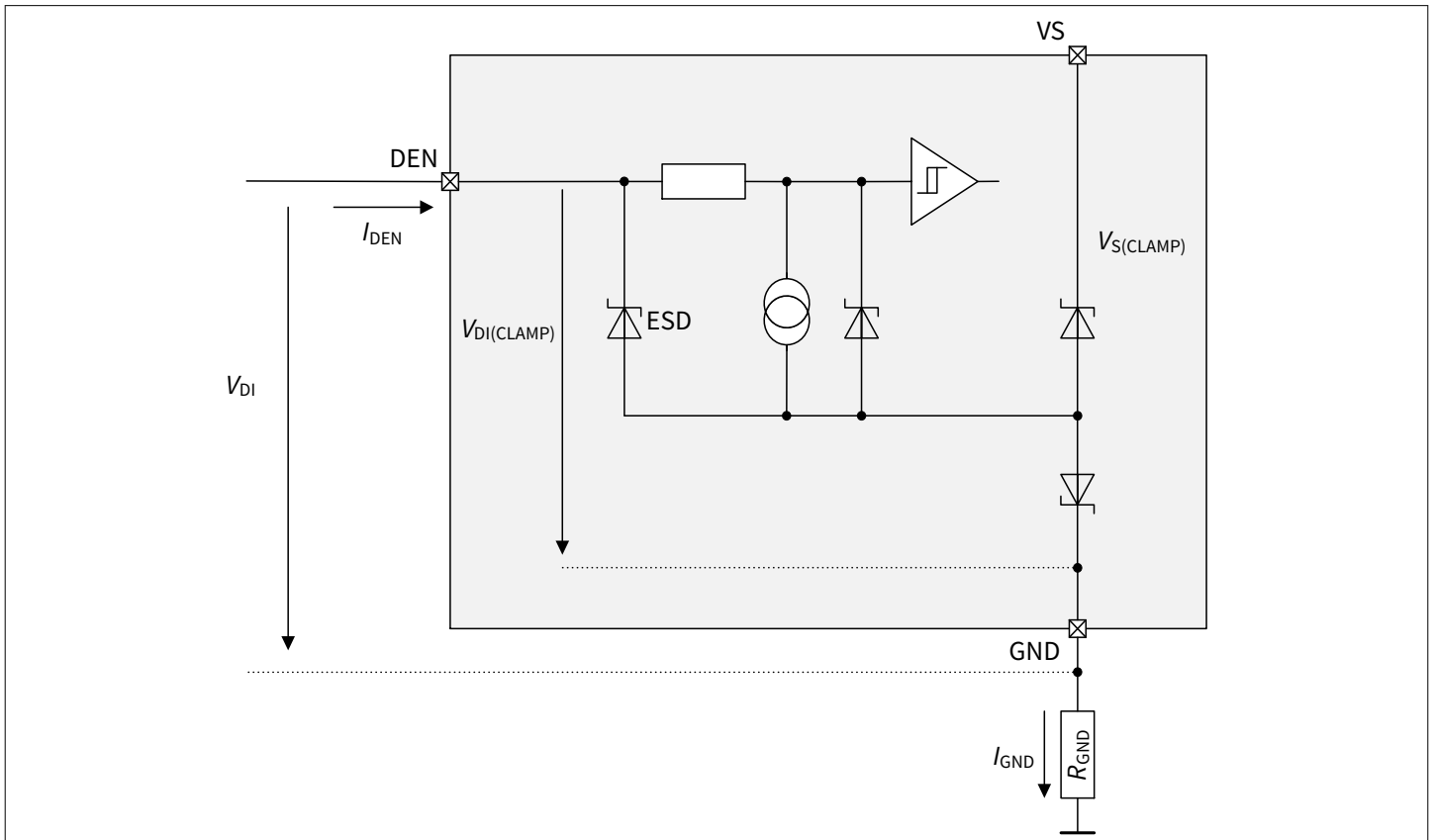

Figure 12 DEN pin circuitry

When the device is in idle mode and the DEN pin is set to "high", the diagnosis is enabled (change from idle mode either to I2t with diagnosis mode or active with diagnosis mode). When the DEN pin is set to "low" and all idle mode conditions are fulfilled, the device changes to idle mode.

The protection latch is reset by applying a pulse (rising edge followed by a falling edge) at the DEN pin while the IN pin is "low" (see Chapter 8.3 and Figure 32 for more details).

5.3 I2t selection pin (I2t)

The I2t selection pin (I2t) is used to select one of the six available I2t protection curves. The selection is made by the value of the resistor connected between I2t pin and GND pin.

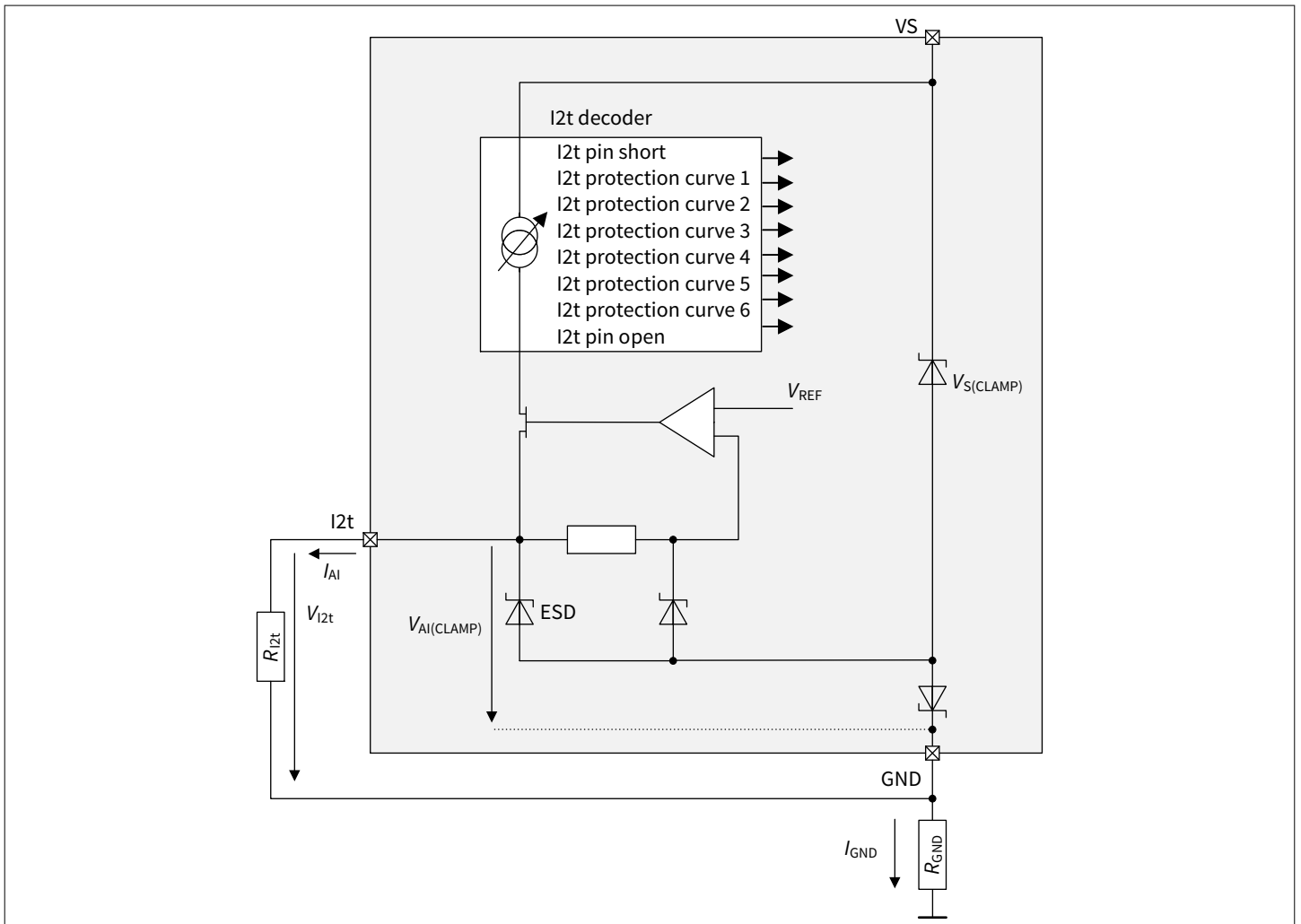

Figure 13 I2t selection circuitry

The device recognizes an I2t pin short if the resistance between I2t pin and GND is lower than R_{I2t_SHORT} . In this case the I2t protection changes to I2t protection curve 1 and additionally a sense current of $I_{IS(I2t_SHORT)}$ is sent out at the IS pin when the sequential diagnosis address #2 is selected.

If the resistance between I2t pin and GND is higher than R_{I2t_OPEN} an I2t pin open is detected by the device. In this case the I2t protection curve 1 is internally selected and additionally a sense current of $I_{IS(I2t_OPEN)}$ is sent out at the IS pin when the sequential diagnosis address #2 is selected.

5.4 Overcurrent threshold pin (OCT)

The overcurrent threshold (OCT) pin is used for an analog adjustment of the overcurrent threshold by connecting a resistor between the OCT pin and GND pin.

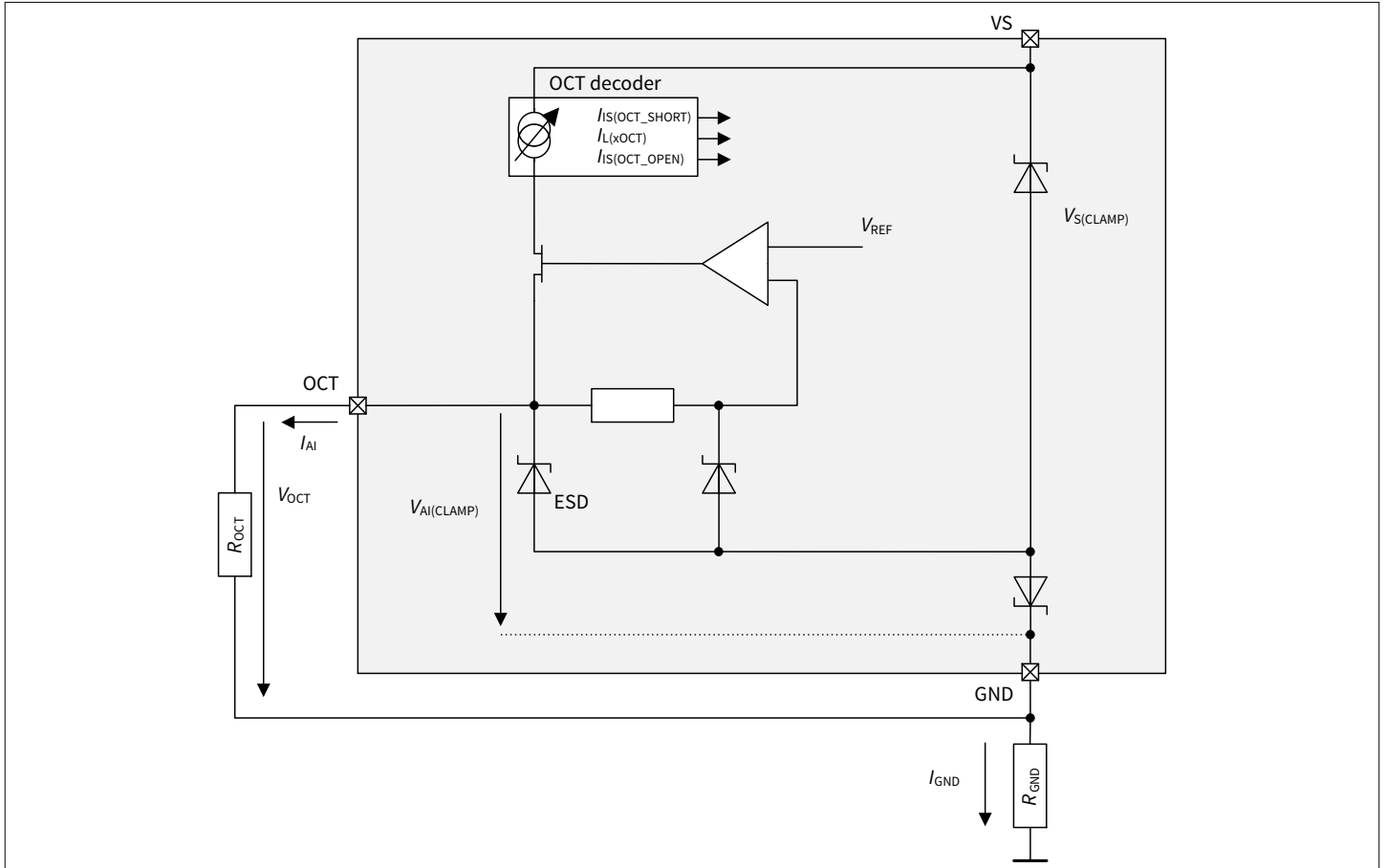

Figure 14 OCT adjustment circuitry

The device recognizes an OCT pin short if the current between the OCT pin and GND is higher than I_{OCT_SHORT} . In this case the overcurrent threshold is internally set to the highest configurable overcurrent threshold $I_{L(HOCT)}$. Additionally, a sense current of $I_{S(OCT_SHORT)}$ is sent out at the IS pin when the sequential diagnosis address #4 is selected.

If the current between the OCT pin and GND is lower than I_{OCT_OPEN} an OCT pin open is detected by the device. In this case the overcurrent threshold is internally set to the highest configurable overcurrent threshold $I_{L(HOCT)}$. Additionally, a sense current of $I_{S(OCT_OPEN)}$ is sent out at the IS pin when the sequential diagnosis address #4 is selected.

5.5 Idle mode pin (IDL)

The idle mode output pin (IDL) is an open drain output. It is set to high impedance in case of idle mode and sleep mode, and it is pulled down in all other modes.

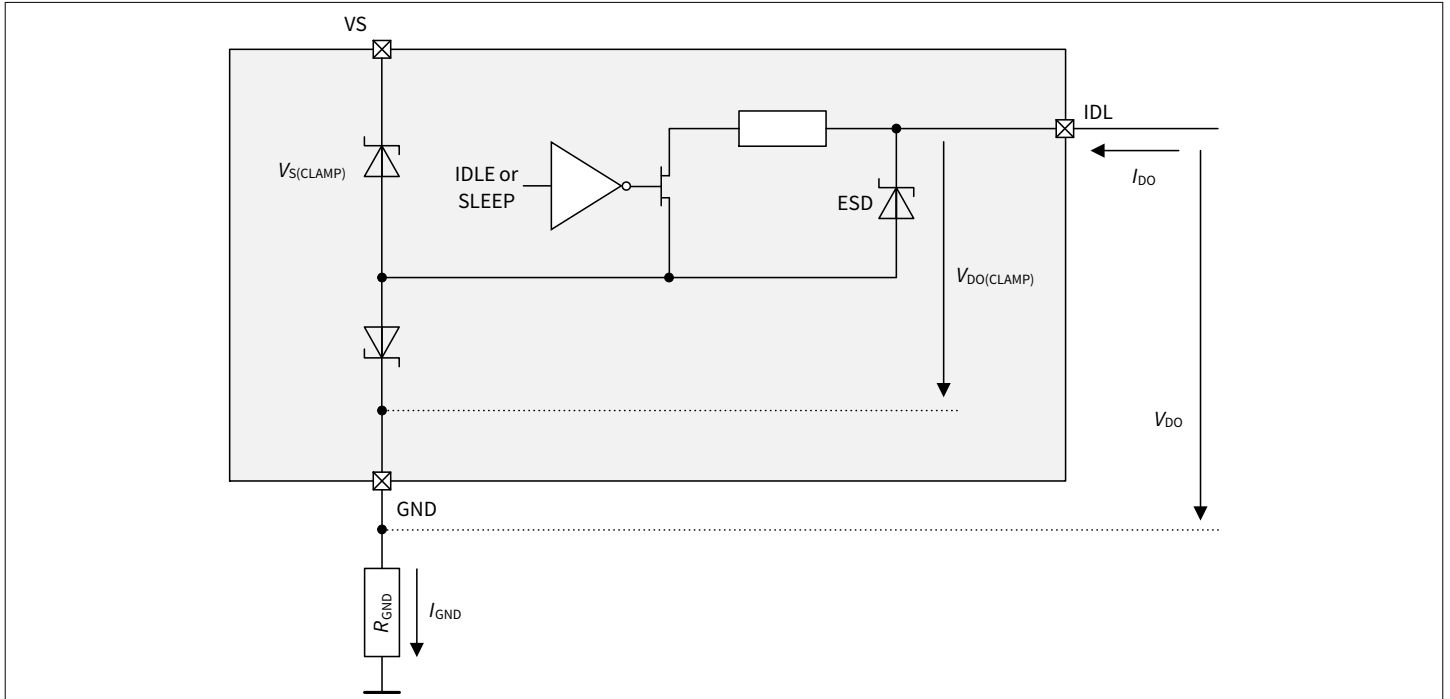

Figure 15 Idle mode pin circuitry

5.6 Electrical characteristics logic pins

Table 6 Electrical characteristics - logic pins

$V_S = 5\text{ V to }20\text{ V}$, $T_J = -40^\circ\text{C to }+150^\circ\text{C}$

Unless otherwise specified typical values: $V_S = 13.5\text{ V}$, $T_J = 25^\circ\text{C}$

Parameter	Symbol	Values			Unit	Note or condition	P-Number
		Min.	Typ.	Max.			

Digital input (DI) pins: IN, DEN

Digital input voltage threshold	$V_{DI(TH)}$	0.8	1.3	2	V	See Figure 10 , Figure 11 and Figure 12	PRQ-168
Digital input clamping voltage	$V_{DI(CLAMP1)}$	–	7	–	V	¹⁾ $I_{DI} = 1\text{ mA}$ See Figure 10 and Figure 12	PRQ-169
Digital input clamping voltage	$V_{DI(CLAMP2)}$	6.5	7.5	8.5	V	$I_{DI} = 2\text{ mA}$ See Figure 10 and Figure 12	PRQ-170
Digital input hysteresis at IN pin	$V_{IN(HYS)}$	0.30	0.45	–	V	¹⁾ See Figure 10 , Figure 11	PRQ-172

(table continues...)

Table 6 (continued) Electrical characteristics - logic pins
 $V_S = 5\text{ V to }20\text{ V}$, $T_J = -40^\circ\text{C to }+150^\circ\text{C}$

 Unless otherwise specified typical values: $V_S = 13.5\text{ V}$, $T_J = 25^\circ\text{C}$

Parameter	Symbol	Values			Unit	Note or condition	P-Number
		Min.	Typ.	Max.			
Digital input hysteresis at DEN pin	$V_{\text{DEN(HYS)}}$	0.20	0.35	–	V	¹⁾ See Figure 10 , Figure 11 and Figure 12	PRQ-1244
Digital input current at IN pin ("high")	$I_{\text{IN(H)}}$	1	10	25	μA	$V_{\text{DI}} = 2\text{ V}$ DEN = "high" See Figure 10	PRQ-173
Digital input current at IN pin ("high")	$I_{\text{IN(H)}}$	-25	-8	-1	μA	$V_{\text{DI}} = 1.4\text{ V}$ DEN = "low" See Figure 10	PRQ-930
Digital input current at IN pin ("low")	$I_{\text{IN(L)}}$	1	10	25	μA	$V_{\text{DI}} = 0.8\text{ V}$ DEN = "high" See Figure 10	PRQ-174
Digital input current at DEN pin ("high")	$I_{\text{DEN(H)}}$	1	10	25	μA	$V_{\text{DI}} = 2\text{ V}$ See Figure 12	PRQ-931
Digital input current at DEN pin ("low")	$I_{\text{DEN(L)}}$	1	10	25	μA	$V_{\text{DI}} = 0.8\text{ V}$ See Figure 12	PRQ-932

Digital output (DO) pin: IDL

Digital output clamping voltage	$V_{\text{DO(CLAMP1)}}$	–	7	–	V	¹⁾ $I_{\text{DO}} = 1\text{ mA}$ Sleep or idle mode (where IDL is highohmic) See Figure 15	PRQ-880
Digital output voltage ("low")	$V_{\text{DO(L)}}$	0	–	0.4	V	$I_{\text{DO}} = 0.2\text{ mA}$ Not in sleep or idle mode (then IDL is low ohmic)	PRQ-367

Analog input (AI) pin: I2t, OCT

Analog input clamping voltage	$V_{\text{AI(CLAMP1)}}$	–	6.5	–	V	¹⁾ $I_{\text{AI}} = -1\text{ mA}$ See Figure 13 and Figure 14	PRQ-881
Maximum analog input current	$I_{\text{AI_MAX}}$	100	300	500	μA	–	PRQ-371
OCT pin reference voltage	V_{OCT}	0.44	0.50	0.55	V	$I_{\text{OCT_MIN}} \leq I_{\text{OCT}} \leq I_{\text{OCT_MAX}}$	PRQ-891

(table continues...)

Table 6 (continued) Electrical characteristics - logic pins

$V_S = 5\text{ V to }20\text{ V}$, $T_J = -40^\circ\text{C to }+150^\circ\text{C}$

Unless otherwise specified typical values: $V_S = 13.5\text{ V}$, $T_J = 25^\circ\text{C}$

Parameter	Symbol	Values			Unit	Note or condition	P-Number
		Min.	Typ.	Max.			
I2t pin reference voltage	V_{I2t}	0.48	0.59	0.69	V	$R_{I2t_MIN} \leq R_{I2t} \leq R_{I2t_MAX}$	PRQ-892

1) Not subject to production test - specified by design.

Table 7 Transition descriptions

Name	Start state	End state	Transition condition	Duration time
pwr _{dw}	Sleep	Unsupplied	$V_{VS} < V_{VS(UV)}$	n.a.
pwr _{up}	Unsupplied	Sleep	$V_{VS} > V_{VS(UV)}$	n.a.
iwd _{slp}	Inactive with diagnosis	Sleep	DEN = "low" AND $S_{I2t_A} < (S_{I2t_I} - S_{I2t_HYST})$	$t_{T(iwd_slp)}$
ina _{slp}	Inactive	Sleep	$S_{I2t_A} < (S_{I2t_I} - S_{I2t_HYST})$	$t_{T(F10u)}$
slp _{i2t}	Sleep	I2t	IN = "high"	t_{ON}
cls _{i2t}	CLS	I2t	(IN = "high" OR $V_{DS} < V_{DS(OLOFF)}$) AND DEN = "low"	$t_{T(CLS_I2t)}$
idle _{I2t}	Idle	I2t	$I_L > I_{L(IDLE)}$	$t_{T(IDLE_I2t)}$
i2twd _{i2t}	I2t with diagnosis	I2t	DEN = "low"	$t_{T(F10u)}$
ina _{i2t}	Inactive	I2t	IN = "high"	t_{ON}
i2t _{cls}	I2t	CLS	IN = "pwm" AND $V_{DS} > V_{DS(OLOFF)}$	$t_{T(I2t_CLS)}$
clswd _{cls}	CLS with diagnosis	CLS	DEN = "low"	$t_{T(F10u)}$
i2t _{idle}	I2t	Idle	$I_L < (I_{L(IDLE)} - I_{L(IDLE_HYST)})$ AND $S_{I2t_A} < (S_{I2t_I} - S_{I2t_HYST})$	$t_{T(I2t_IDLE)}$
awd _{idle}	Active with diagnosis	Idle	DEN = "low"	$t_{T(AWD_IDLE)}$
idle _{awd}	Idle	Active with diagnosis	DEN = "high"	$t_{T(F10u)}$
i2t _{i2twd}	I2t	I2t with diagnosis	DEN = "high"	$t_{SIS(ON15)}$
awd _{i2twd}	Active with diagnosis	I2t with diagnosis	$I_L > I_{L(IDLE)}$	$t_{SIS(ON15)}$
clswd _{i2twd}	CLS with diagnosis	I2t with diagnosis	IN = "high" OR $V_{DS} < V_{DS(OLOFF)}$	$t_{T(CLS_I2t)}$
iwd _{i2twd}	Inactive with diagnosis	I2t with diagnosis	IN = "high"	t_{ON}
cls _{clswd}	CLS	CLS with diagnosis	DEN = "high"	$t_{SIS(ON234)}$
i2twd _{clswd}	I2t with diagnosis	CLS with diagnosis	IN = "pwm" AND $V_{DS} > V_{DS(OLOFF)}$	$t_{T(I2t_CLS)}$
slp _{iwd}	Sleep	Inactive with diagnosis	DEN = "high"	$t_{SIS(ON234)}$
awd _{iwd}	Active with diagnosis	Inactive with diagnosis	IN = "low"	t_{OFF}
i2twd _{iwd}	I2t with diagnosis	Inactive with diagnosis	IN = "low"	t_{OFF}

(table continues...)

Table 7 (continued) Transition descriptions

Name	Start state	End state	Transition condition	Duration time
clswd_iwd	CLS with diagnosis	Inactive with diagnosis	IN = "low"	t_{OFF}
ina_iwd	Inactive	Inactive with diagnosis	DEN = "high"	$t_{SIS(ON234)}$
i2t_ina	I2t	Inactive	IN = "low"	t_{OFF}
cls_ina	CLS	Inactive	IN = "low"	t_{OFF}
idle_ina	Idle	Inactive	IN = "low"	t_{OFF}
iwd_ina	Inactive with diagnosis	Inactive	DEN = "low"	$t_{T(F10u)}$

6.1.1 Unsupplied

In this state the device is either unsupplied (no voltage applied to VS pin) or the supply voltage is below the undervoltage threshold.

6.1.2 Power-up

The power-up condition is entered when the supply voltage (V_S) is applied to the device. The supply is rising until it is above the minimum operating output voltage $V_{S(OP)}$, therefore the internal power-on signals are set.

6.1.3 Sleep mode

The device is in sleep mode when all digital input pins (IN, DEN) are set to "low" and the I2t status calculation is below the initial status S_{I2t_I} minus the I2t status hysteresis S_{I2t_HYST} . When the device is in sleep mode, the output is OFF. The current consumption is minimum (see parameter $I_{VS(SLEEP)}$). No overtemperature or overcurrent protection mechanism is active when the device is in sleep mode. If a protection was previously triggered and has not been reset, the device will not enter sleep mode (see [Chapter 8.3.1](#) for further details).

6.1.4 I2t mode

The I2t mode is entered as soon as the IN pin is set to "high". The device is calculating the I2t status S_{I2t} and switches the channel OFF as soon as the I2t protection function (selected curve) is triggered. A detailed explanation of the I2t status calculation can be found in [Chapter 9.1](#). The current consumption is specified with $I_{GND(I2t_D)}$ (measured at GND pin because the current at VS pin includes the load current). Overcurrent, overtemperature and overvoltage protections are active. Since the DEN pin is set to "low" the diagnosis is not available.

6.1.5 Inactive with diagnosis mode

The device is in inactive with diagnosis mode as long as DEN pin is set to "high" while input pin is set to "low". The channel is OFF. The initial I2t status value for the I2t status calculation depends on the actual I2t status. A detailed explanation of the I2t status calculation can be found in [Chapter 9.1](#). The current consumption is specified by the parameter operating current in inactive with diagnosis mode $I_{GND(INACT_D)}$. Additionally, the sequential diagnosis is enabled and depending on the address the selected setting is present at the IS pin (for further information see [Figure 42](#)).

6.1.6 I2t with diagnosis mode

The device enters I2t with diagnosis mode as soon as the IN and DEN pin are set to "high". Similar to I2t mode the device is calculating the I2t status S_{I2t} and switches the channel OFF as soon as the I2t protection function (selected curve) is triggered. A detailed explanation of the I2t status calculation can be found in [Chapter 9.1](#). The current

consumption is specified with $I_{\text{GND}(I2t_D)}$ (measured at GND pin because the current at VS pin includes the load current). Overcurrent, overtemperature and overvoltage protections are active. Additionally, the sequential diagnosis is enabled and depending on the address the selected setting is present at the IS pin (for further information see [Figure 42](#)).

6.1.7 Idle mode

Idle mode is the low power mode of the device where the current consumption is reduced to $I_{\text{GND}(\text{IDLE})}$ while the output channel stays ON. Idle mode is entered automatically when the device fulfills the following idle mode entry conditions:

- IN pin is set to "high"
- Load current level is below $I_{\text{L}(\text{IDLE})} - I_{\text{L}(\text{IDLE_HYST})}$
- DEN pin is set to "low"
- I2t protection status calculation $S_{I2t_A} < (S_{I2t_I} - S_{I2t_HYST})$

The idle mode is left when the device fulfills one of the following idle mode exit conditions:

- IN pin is set to "low"
- Load current level is above $I_{\text{L}(\text{IDLE})}$
- DEN pin is set to "high"

During idle mode the I2t protection as well as the temperature protection and sequential diagnosis function is not active.

6.1.8 Active with diagnosis

The active with diagnosis state is entered out of idle mode when the DEN pin is set to "high" and $I_{\text{L}} < I_{\text{L}(\text{IDLE})}$. The transition time from active with diagnosis to idle is defined by $t_{\text{T}(\text{awd_idle})}$. During this state the I2t calculation is not active since $I_{\text{L}} < I_{\text{L}(\text{IDLE})}$ and no $I_{\text{L}(I2t_I)}$ is applied. The current consumption is specified with $I_{\text{GND}(I2t_D)}$ (measured at GND pin because the current at VS pin includes the load current). Overcurrent, overtemperature and overvoltage protections are active. Additionally, the sequential diagnosis is enabled and depending on the address the selected setting is present at the IS pin (for further information see [Figure 42](#)).

6.1.9 CLS mode

The device has a capacitive load switching (CLS) mode implemented to charge capacitive loads. To enter the CLS mode an input frequency of $f_{\text{VIN}(\text{CLS})}$ with the duty cycle of $DC_{\text{VIN}(\text{CLS})}$ has to be applied at the input pin (for more details see [Chapter 7.2.3](#)). The device current consumption in CLS mode is specified by the parameter $I_{\text{GND}(I2t_D)}$.

6.1.10 CLS with diagnosis mode

The CLS with diagnosis mode is entered as soon as the pwm signal for CLS mode ($f_{\text{VIN}(\text{CLS})}$ and $DC_{\text{VIN}(\text{CLS})}$) is applied at the IN pin and the DEN pin is set to "high". The device calculates the I2t status S_{I2t} (with $I_{\text{L}}=0$ A). Overcurrent, overtemperature and overvoltage protections are active. Additionally, the sequential diagnosis is enabled. Depending on the address several settings are present at the IS pin (for further information see [Figure 42](#)). The device current consumption is specified by the parameter $I_{\text{GND}(I2t_D)}$.

6.1.11 Inactive mode

The inactive mode is a transition mode between I2t mode to sleep mode or idle mode to sleep mode. The device enters inactive mode as soon as the IN pin is set to "low" while the DEN pin is "low". The device stays in this mode until the I2t status calculation has reached a value below the I2t hysteresis curve. The channel is OFF and the current consumption is specified by the parameter $I_{\text{GND}(I2t_D)}$.

6.1.12 Fault mode

The device is in fault mode as soon as a device protection or I2t protection event happen. The output then switches off. In fault mode, with IN="high" and DEN="high", $I_{\text{IS}(\text{FAULT})}$ is present and no sequential diagnosis is available at the IS pin. With IN = "low" and DEN = "high" sequential diagnosis is available (for details see [Chapter 10](#)) at the IS pin.

6.2 Undervoltage on VS

The undervoltage mechanism is triggered below $V_{S(UV)}$ or $V_{S(UV_IDLE)}$.

If the device is operative (in I2t mode, I2t with diagnosis mode, CLS mode, CLS with diagnosis mode, inactive mode or inactive with diagnosis mode, active with diagnosis mode) and the supply voltage drops below the undervoltage threshold $V_{S(UV)}$, the internal logic switches OFF the output channel and the I2t calculation is reset.

The power supply undervoltage shutdown in idle mode is triggered when the supply voltage drops below $V_{S(UV_IDLE)}$ during idle mode, resulting in the switch OFF of the output channel.

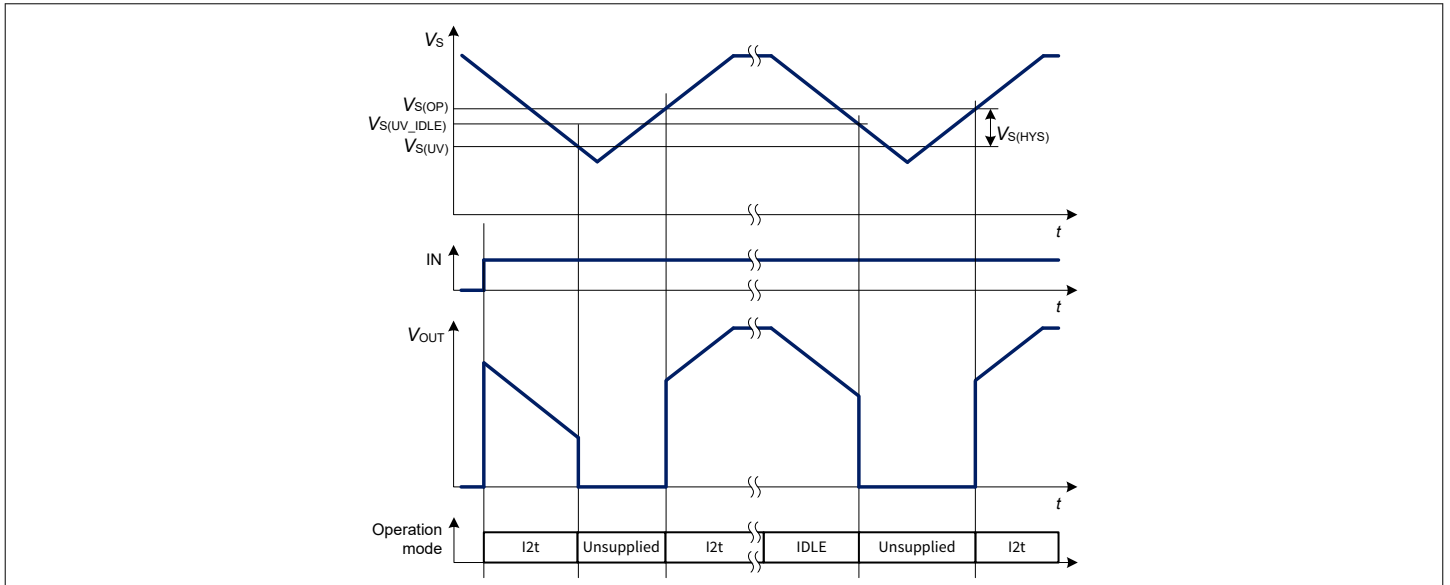

Figure 17 V_S undervoltage behavior

6.3 Electrical characteristics power supply

Table 8 Electrical characteristics - power supply

$T_J = -40^\circ\text{C}$ to $+150^\circ\text{C}$

Unless otherwise specified typical values: $T_J = 25^\circ\text{C}$

Typical resistive loads connected to the outputs for testing (unless otherwise specified): $R_L = 2.1 \Omega$

Parameter	Symbol	Values			Unit	Note or condition	P-Number
		Min.	Typ.	Max.			
Power supply undervoltage shutdown (normal)	$V_{S(UV)}$	2.0	2.4	2.75	V	V_S decreasing IN = "high" From $V_{DS} \leq 0.5 \text{ V}$ to $V_{DS} = V_S$	PRQ-186
Power supply undervoltage shutdown in idle	$V_{S(UV_IDLE)}$	2.3	2.6	2.9	V	V_S decreasing Idle mode IN = "high" From $V_{DS} \leq 0.5 \text{ V}$ to $V_{DS} = V_S$	PRQ-1434

(table continues...)

Table 8 (continued) Electrical characteristics - power supply
 $T_J = -40^{\circ}\text{C}$ to $+150^{\circ}\text{C}$

 Unless otherwise specified typical values: $T_J = 25^{\circ}\text{C}$

 Typical resistive loads connected to the outputs for testing (unless otherwise specified): $R_L = 2.1\ \Omega$

Parameter	Symbol	Values			Unit	Note or condition	P-Number
		Min.	Typ.	Max.			
Power supply minimum operating voltage	$V_{S(OP)}$	2.2	3.1	4.1	V	V_S increasing IN = "high" From $V_{DS} = V_S$ to $V_{DS} \leq 0.5\ \text{V}$	PRQ-188
Power supply undervoltage shutdown hysteresis	$V_{S(HYS)}$	–	0.75	–	V	¹⁾ $V_{S(OP)} - V_{S(UV)}$	PRQ-190

¹⁾ Not subject to production test - specified by design.

6.3.1 Electrical characteristics - power supply

Table 9 Power supply
 $V_S = 5\ \text{V}$ to $20\ \text{V}$, $T_J = -40^{\circ}\text{C}$ to $+150^{\circ}\text{C}$

 Unless otherwise specified typical values: $V_S = 13.5\ \text{V}$, $T_J = 25^{\circ}\text{C}$

 Typical resistive loads connected to the outputs for testing (unless otherwise specified): $R_L = 2.1\ \Omega$

Parameter	Symbol	Values			Unit	Note or condition	P-Number
		Min.	Typ.	Max.			
Transition times							
Transition time for fast transition	$t_{T(F10u)}$	–	15	25	μs	¹⁾	PRQ-1377
Transition time cls mode to I2t mode	$t_{T(CLS_I2t)}$	–	40	80	μs	¹⁾	PRQ-1376
Transition time idle mode to I2t mode	$t_{T(IDLE_I2t)}$	9	15.5	24	μs	¹⁾	PRQ-1378
Transition time active with diagnosis mode to idle mode	$t_{T(AWD_IDLE)}$	210	280	350	μs	¹⁾	PRQ-1379
Transition time I2t mode to cls mode	$t_{T(I2t_CLS)}$	30	70	140	μs	¹⁾	PRQ-1380
Transition time inactive with diagnosis mode to sleep mode	$t_{T(iwd_slp)}$	150	210	300	μs	¹⁾	PRQ-1410

(table continues...)

Table 9 (continued) Power supply
 $V_S = 5\text{ V to }20\text{ V}$, $T_J = -40^\circ\text{C to }+150^\circ\text{C}$

 Unless otherwise specified typical values: $V_S = 13.5\text{ V}$, $T_J = 25^\circ\text{C}$

 Typical resistive loads connected to the outputs for testing (unless otherwise specified): $R_L = 2.1\ \Omega$

Parameter	Symbol	Values			Unit	Note or condition	P-Number
		Min.	Typ.	Max.			
Current consumption							
Supply current consumption in sleep mode with loads at $T_J \leq 85^\circ\text{C}$	$I_{VS(\text{SLEEP})_85}$	–	0.03	0.2	μA	1) $V_S = 20\text{ V}$ $V_{\text{OUT}} = V_{\text{I2t}} = V_{\text{OCT}} = 0\text{ V}$ IN = DEN = "low" $T_J \leq 85^\circ\text{C}$	PRQ-1006
Supply current consumption in sleep mode with loads at $T_J = 150^\circ\text{C}$	$I_{VS(\text{SLEEP})_150}$	–	0.25	5	μA	$V_S = 20\text{ V}$ $V_{\text{OUT}} = V_{\text{I2t}} = V_{\text{OCT}} = 0\text{ V}$ IN = DEN = "low" $T_J = 150^\circ\text{C}$	PRQ-1007
Operating current in inactive with diagnosis mode	$I_{\text{GND}(\text{INACT_D})}$	–	1.5	2.3	mA	$V_S = 20\text{ V}$ IN = "low" DEN = "high"	PRQ-197
Operating current in I2t with diagnosis mode (channel ON)	$I_{\text{GND}(\text{I2t_D})}$	–	5	7.4	mA	$V_S = 20\text{ V}$ IN = DEN = "high"	PRQ-195
Operating current in idle mode (channel ON)	$I_{\text{GND}(\text{IDLE})}$	–	50	60	μA	$V_S = 20\text{ V}$ IN = "high" DEN = "low" $I_L < I_{L(\text{IDLE})}$	PRQ-355
Idle currents							
Load current hysteresis for idle mode entry	$I_{L(\text{IDLE_HYST})}$	–	0.055	–	A	1) See Chapter 6.1.7	PRQ-1461
Load current threshold for idle mode exit	$I_{L(\text{IDLE})}$	0.5	1.3	2.1	A	See Chapter 6.1.7	PRQ-1009

1) Not subject to production test - specified by design.

7 Power stages

The high-side power stage is built using an N-channel vertical power MOSFET with charge pump.

7.1 Output ON-state resistance

The ON-state resistance $R_{DS(ON)}$ depends mainly on junction temperature T_J . Figure 18 shows the variation of $R_{DS(ON)}$ across the whole T_J range. The value “2” on the y-axis corresponds to the maximum $R_{DS(ON)}$ measured at $T_J = 150^\circ\text{C}$.

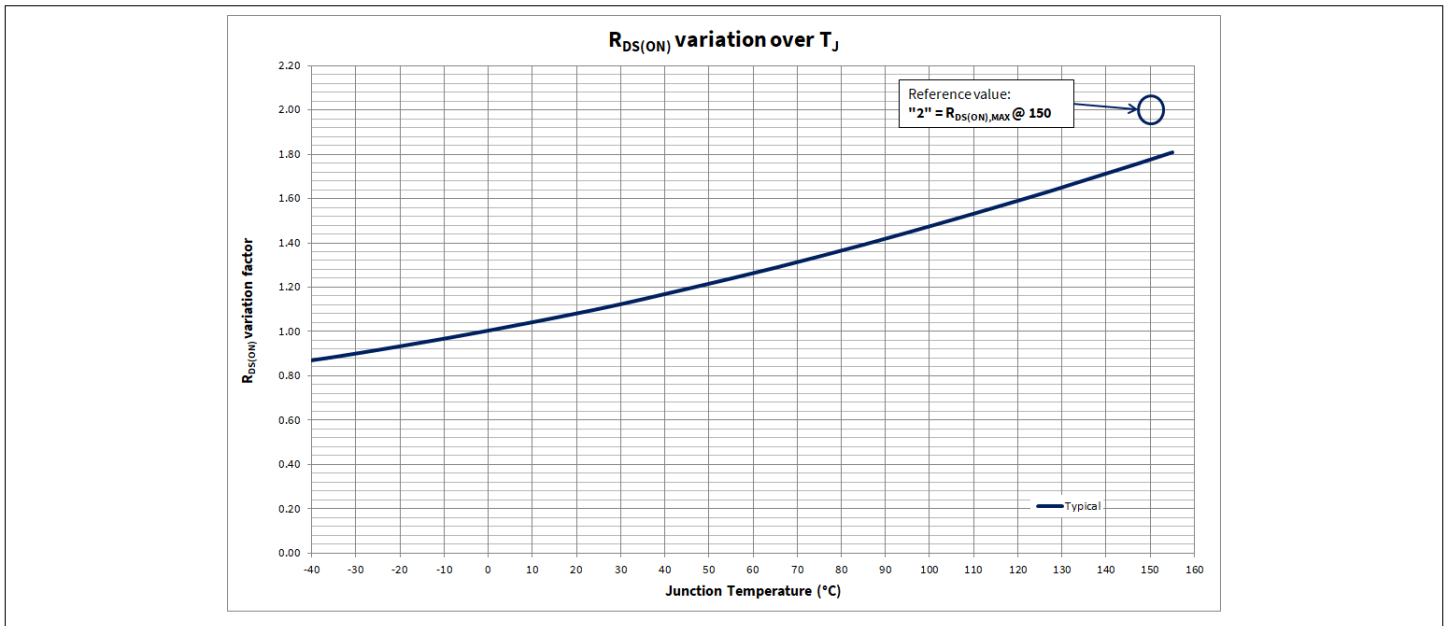

Figure 18 $R_{DS(ON)}$ variation factor

The behavior in reverse polarity is described in [Chapter 8.4.1](#).

7.2 Switching loads

7.2.1 Switching resistive loads

When switching resistive loads, the switching times and slew rates shown in [Figure 19](#) can be considered. The switch energy values E_{ON} and E_{OFF} are proportional to load resistance and times t_{ON} and t_{OFF} .

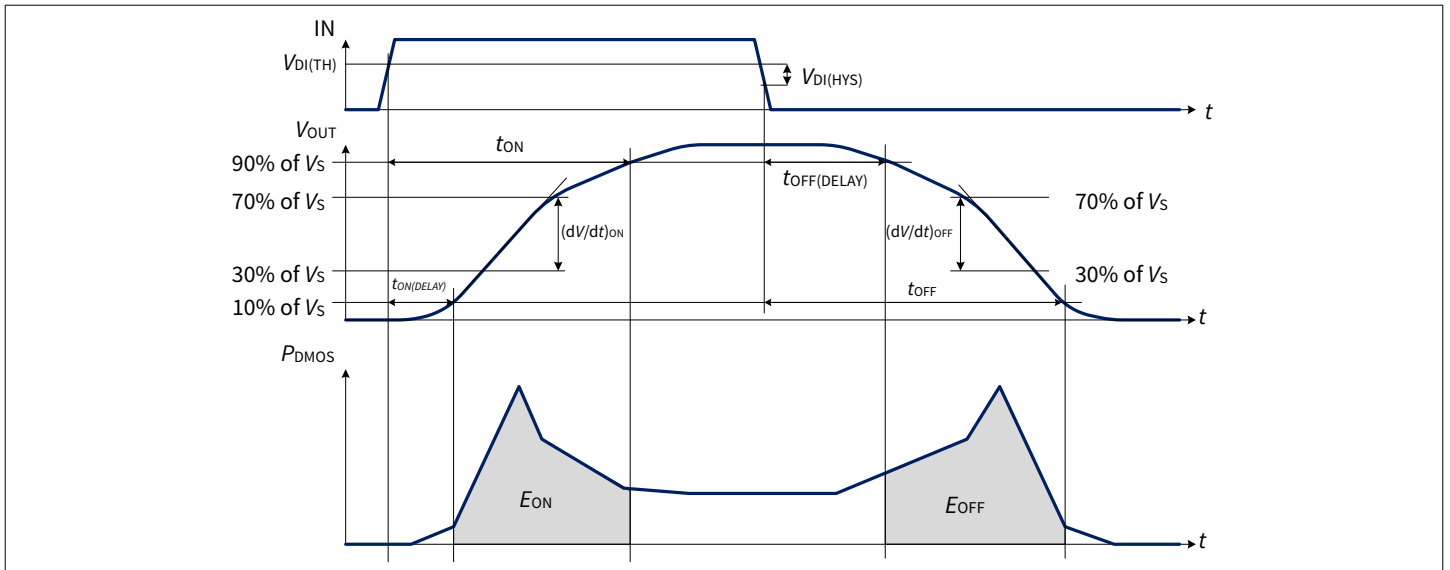

Figure 19 Switching a resistive load

7.2.2 Switching inductive loads

When switching OFF inductive loads with high-side switches, the voltage V_{OUT} drops below ground potential because the inductance intends to continue driving the current. To prevent the destruction of the device due to overvoltage, a voltage clamp mechanism is implemented. The clamping structure limits the negative output voltage so that $V_{DS} = V_{DS(CLAMP)}$. Figure 20 shows a concept drawing of the implementation.

The clamping structure is available in all operation modes listed in Chapter 6.1.

All clamping structures ($V_{IS(CLAMP)}$, $V_{S(CLAMP)}$, $V_{DS(CLAMP)}$) are implemented with respect to V_S supply.

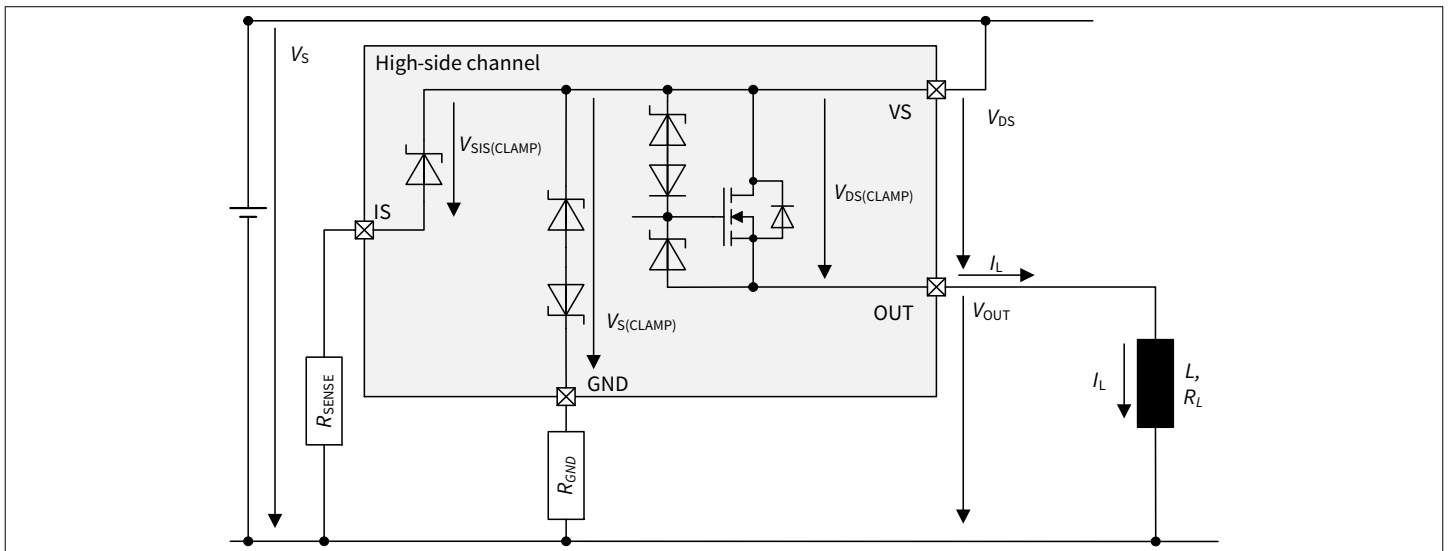

Figure 20 Output clamp concept

During demagnetization of inductive loads, energy has to be dissipated in the device. The energy can be calculated using:

$$E = V_{DS(CLAMP)} \cdot \left[\frac{V_S - V_{DS(CLAMP)}}{R_L} \cdot \ln\left(1 - \frac{R_L \cdot I_L}{V_S - V_{DS(CLAMP)}}\right) + I_L \right] \cdot \frac{L}{R_L} \quad (1)$$

The maximum energy, therefore the maximum inductance for a given current, is limited by the thermal design of the component. Please refer to [Table 3](#) for the maximum allowed values of E_{AS} (single pulse energy) and E_{AR} (repetitive energy).

7.2.3 Capacitive load switching

When switching a resistive load with the capacitive load switching (CLS) mode the switching times as well as the slew rate will change to t_{ON_CLS} , $t_{ON_CLS(DELAY)}$, $(dV/dt)_{ON_CLS}$ as shown in [Figure 21](#). The CLS mode is entered by applying a PWM signal at the IN pin with a frequency of $f_{VIN(CLS)}$ and a duty cycle of $DC_{VIN(CLS)}$.

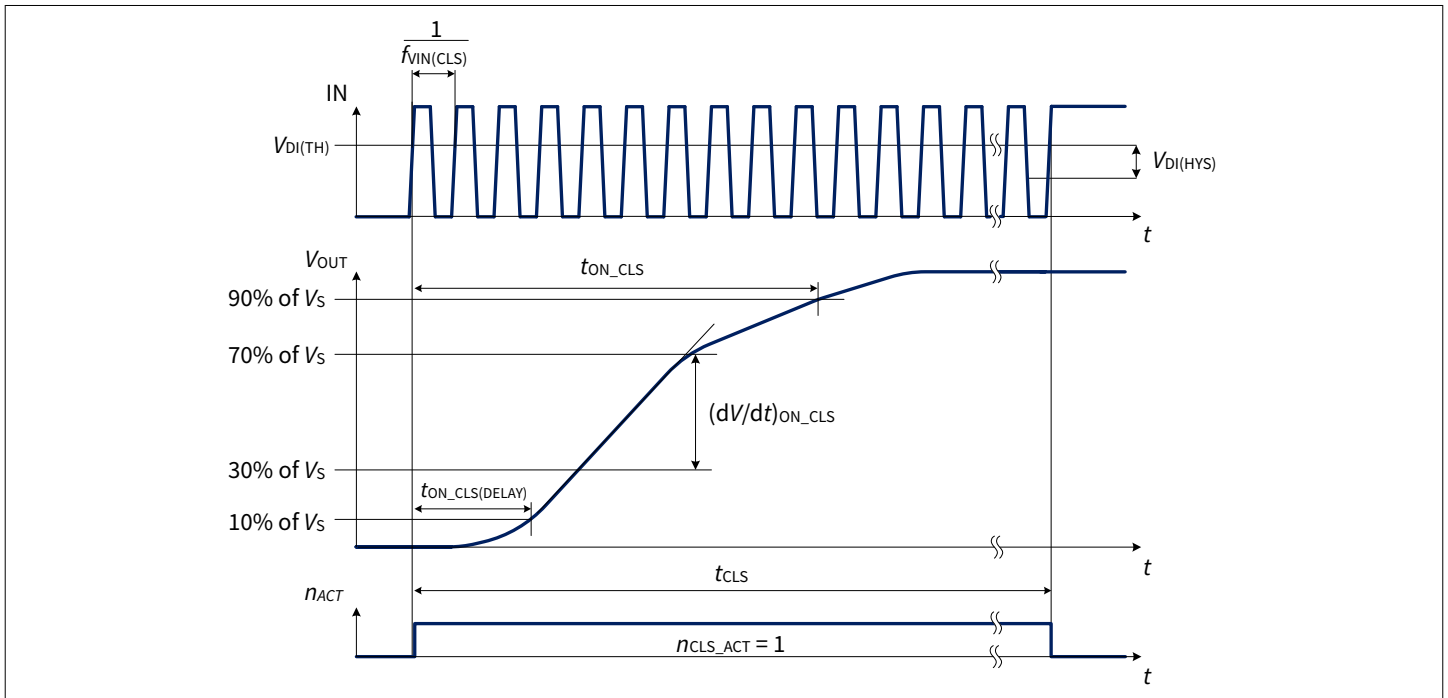

Figure 21 Capacitive load switching timings

During this mode the dynamic thermal shut down temperature is reduced to $T_{J_CLS(DYN)}$ and the device is set to auto-restart.

The CLS mode and CLS with diagnosis mode has to be left after a maximum time of t_{CLS} by setting the input to "high" or "low" state. The highest configurable overcurrent detection threshold $I_{L(HOCT)}$ (for $I_{OCT} = 50 \mu A$) is enabled and the overtemperature protections are active (see [Figure 29](#)).

The device calculates the I2t status S_{I2t} (with $I_L = 0 A$).

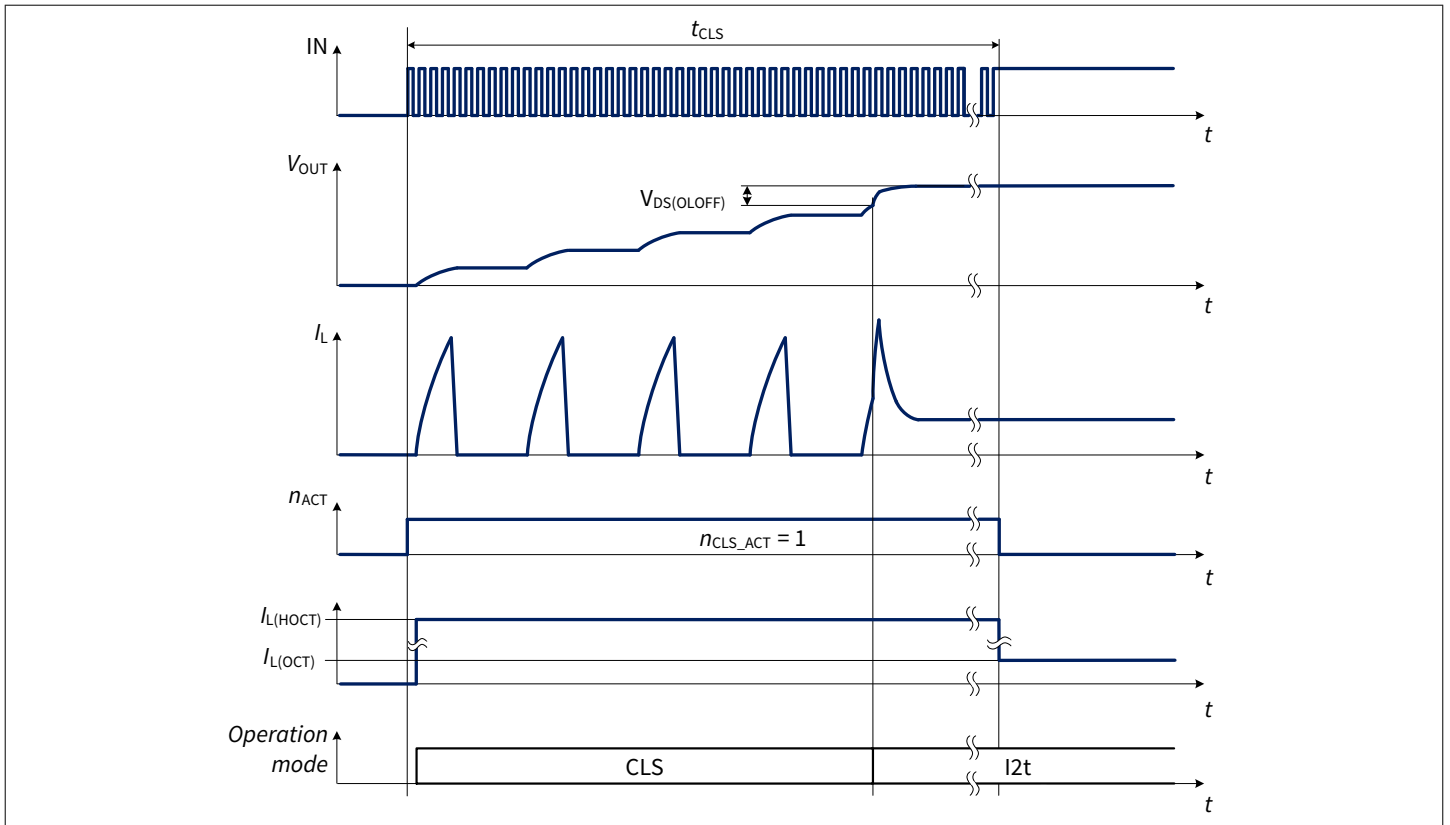

Figure 22 Capacitive load switching activations

A transition from the CLS mode to the ON mode is automatically done when $V_{DS} < V_{DS(OLOFF)}$. Before changing from CLS mode (IN = "pwm") to I2t mode (IN = "high"), it must be ensured that there is no short circuit at the output. To distinguish between short circuit and normal load, a current sense measurement must be performed before leaving CLS mode. If the current measurement delivers an expected value, the transition from CLS mode to normal mode is possible. If the current measurement delivers an open load value (no output current), it has to be assumed that there is either an open load or a short circuit at the output. Additionally, a short circuit condition can be excluded by an external voltage measurement at the output.

7.3 Advanced switching characteristics

7.3.1 Inverse current behavior

If $V_{OUT} > V_S$, a current $I_{L(INV)}$ flows into the power output transistor (see Figure 23). This condition is known as "inverse current".

If the channel is in OFF state, the current flows through the intrinsic body diode generating high power losses. Therefore, the overall device temperature increases. If the channel is in ON state, $R_{DS(INV)}$ can be expected and power dissipation in the output stage is comparable to normal operation in $R_{DS(ON)}$.

During Inverse ON condition, the channel remains in ON or OFF state as long as $|-I_L| < |-I_{L(INV)}|$. It is possible to switch ON the channel during inverse current condition as long as $|-I_L| < |-I_{L(INV)}|$ (see Figure 24).

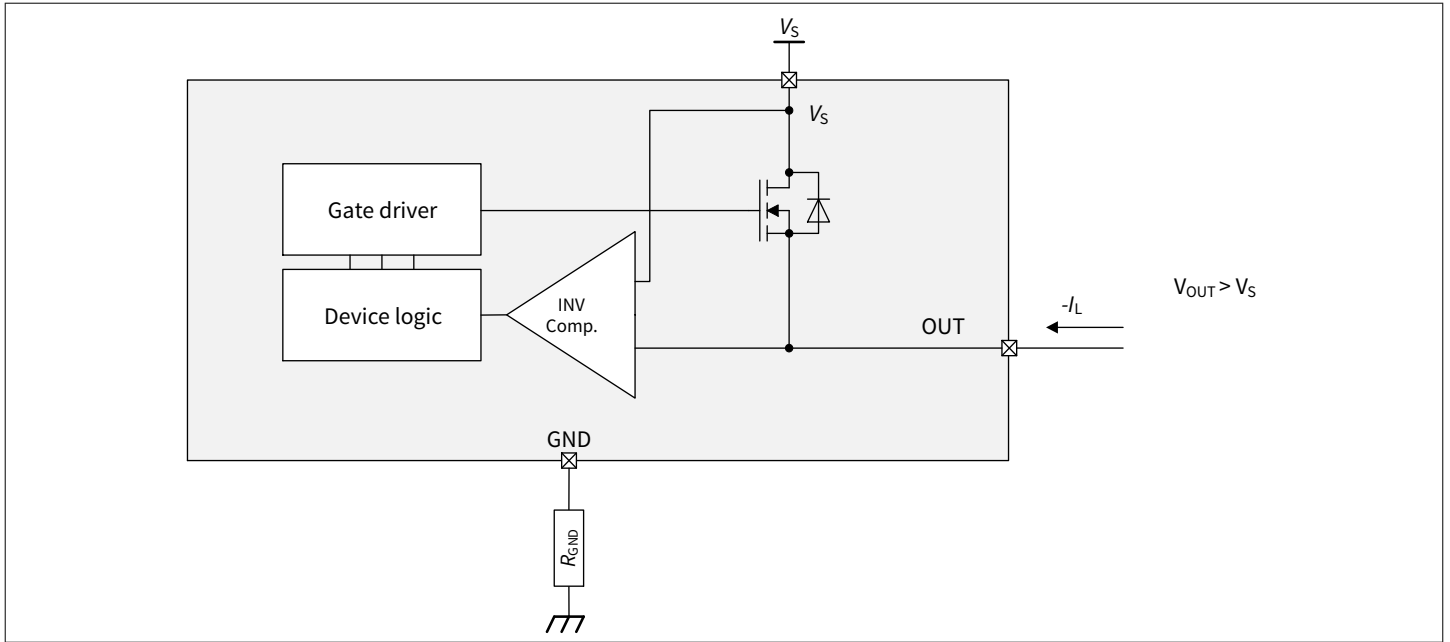

Figure 23 Inverse current circuitry

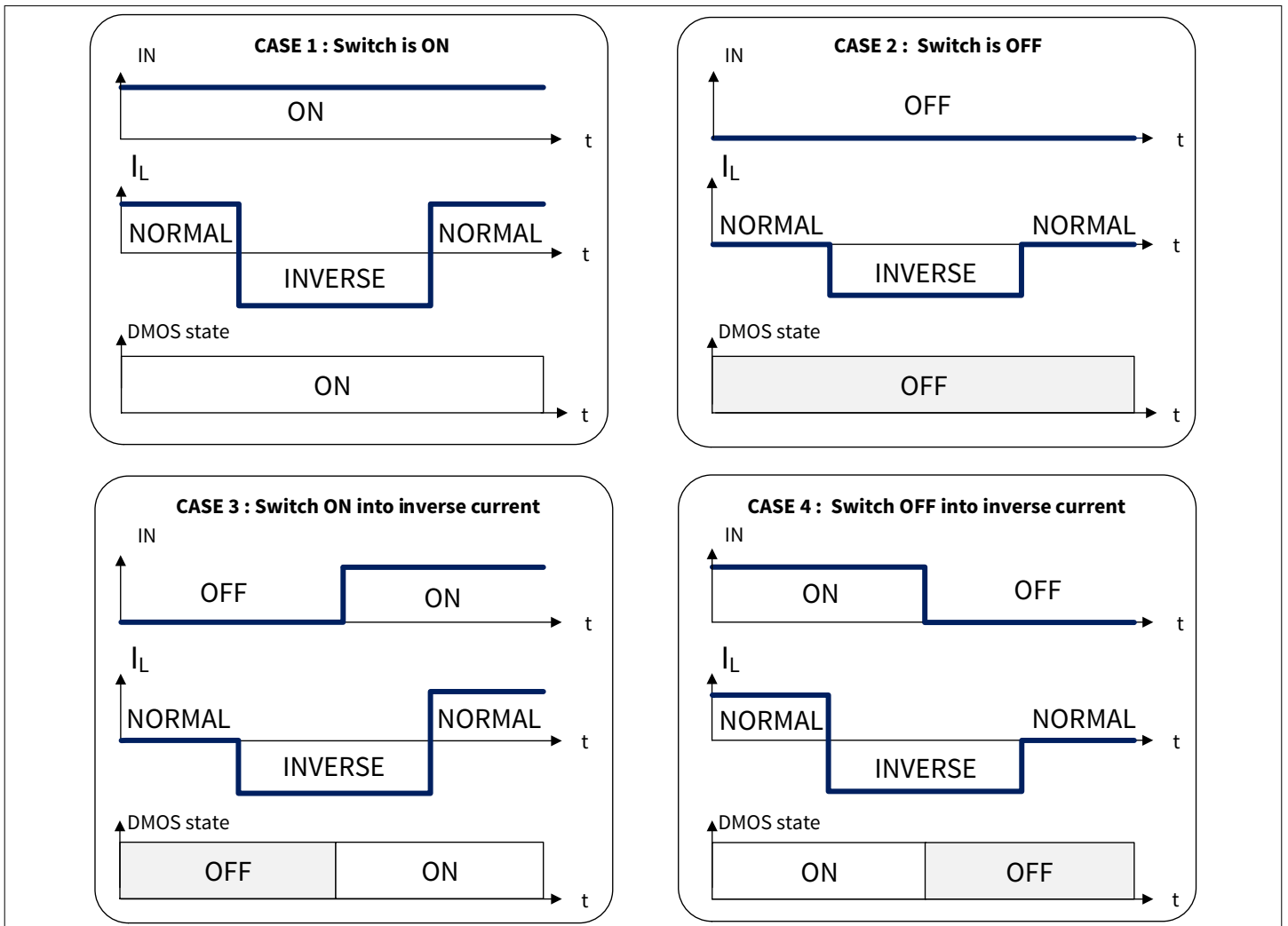

Figure 24 Inverse ON - channel behavior in case of applied inverse current

No protection mechanism like overtemperature or overcurrent protection is active during applied inverse currents.

7.4 Electrical characteristics power stages

Table 10 Electrical characteristics power stages

$V_S = 5\text{ V to }20\text{ V}$, $T_J = -40^\circ\text{C to }+150^\circ\text{C}$

Unless otherwise specified typical values: $V_S = 13.5\text{ V}$, $T_J = 25^\circ\text{C}$

Typical resistive loads connected to the outputs for testing (unless otherwise specified): $R_L = 2.1\ \Omega$

Parameter	Symbol	Values			Unit	Note or condition	P-Number
		Min.	Typ.	Max.			
Voltages							
Drain to source clamping voltage at $T_J = -40^\circ\text{C}$	$V_{DS(\text{CLAMP})_{-40}}$	33	36.5	42	V	$I_L = 5\text{ mA}$ $T_J = -40^\circ\text{C}$ See Figure 20	PRQ-203
Drain to source clamping voltage at $T_J \geq 25^\circ\text{C}$	$V_{DS(\text{CLAMP})_{25}}$	35	38	44	V	1) $I_L = 5\text{ mA}$ $T_J \geq 25^\circ\text{C}$ See Figure 20	PRQ-204
Timings							
Switch-ON delay	$t_{\text{ON}(\text{DELAY})}$	10	50	90	μs	$V_S = 13.5\text{ V}$ $V_{\text{OUT}} = 10\% V_S$ See Figure 19	PRQ-205
Switch-ON delay in CLS	$t_{\text{ON_CLS}(\text{DELAY})}$	150	500	850	μs	$V_S = 13.5\text{ V}$ $V_{\text{OUT}} = 10\% V_S$ See Figure 21	PRQ-591
Switch-OFF delay	$t_{\text{OFF}(\text{DELAY})}$	10	75	140	μs	$V_S = 13.5\text{ V}$ $V_{\text{OUT}} = 90\% V_S$ See Figure 19	PRQ-206
Switch-ON time	t_{ON}	40	100	160	μs	$V_S = 13.5\text{ V}$ $V_{\text{OUT}} = 90\% V_S$ See Figure 19	PRQ-207
Switch-ON time in CLS	$t_{\text{ON_CLS}}$	350	1075	1800	μs	$V_S = 13.5\text{ V}$ $V_{\text{OUT}} = 90\% V_S$ See Figure 21	PRQ-592
Switch-OFF time	t_{OFF}	50	120	190	μs	$V_S = 13.5\text{ V}$ $V_{\text{OUT}} = 10\% V_S$ See Figure 19	PRQ-208
Switch-ON/OFF matching ($t_{\text{ON}} - t_{\text{OFF}}$)	Δt_{SW}	-90	-20	50	μs	$V_S = 13.5\text{ V}$	PRQ-209

(table continues...)

Table 10 (continued) Electrical characteristics power stages

$V_S = 5\text{ V to }20\text{ V}$, $T_J = -40^\circ\text{C to }+150^\circ\text{C}$

Unless otherwise specified typical values: $V_S = 13.5\text{ V}$, $T_J = 25^\circ\text{C}$

Typical resistive loads connected to the outputs for testing (unless otherwise specified): $R_L = 2.1\ \Omega$

Parameter	Symbol	Values			Unit	Note or condition	P-Number
		Min.	Typ.	Max.			
Input frequency for capacitive load switching mode	$f_{VIN(CLS)}$	22	30	38	kHz	²⁾ $DC_{VIN(CLS)} = 50\%$	PRQ-588
Duty cycle for capacitive load switching	$DC_{VIN(CLS)}$	30%	50%	70%	–	²⁾ $f_{VIN(CLS)} = 30\text{ kHz}$	PRQ-589

Voltage slope

Switch-ON slew rate	$(dV/dt)_{ON}$	0.16	0.27	0.39	V/ μ s	$V_S = 13.5\text{ V}$ $V_{OUT} = 30\% V_S \text{ to } 70\% V_S$ See Figure 19	PRQ-210
Switch-ON slew rate in CLS	$(dV/dt)_{ON_CLS}$	0.007	0.018	0.032	V/ μ s	$V_S = 13.5\text{ V}$ $V_{OUT} = 30\% V_S \text{ to } 70\% V_S$ See Figure 21	PRQ-1487
Switch-OFF slew rate	$(dV/dt)_{OFF}$	-0.39	-0.27	-0.16	V/ μ s	$V_S = 13.5\text{ V}$ $V_{OUT} = 70\% V_S \text{ to } 30\% V_S$ See Figure 19	PRQ-211
Slew rate matching (dV/dt) _{ON} - (dV/dt) _{OFF}	$\Delta(dV/dt)_{SW}$	-0.15	0	0.15	V/ μ s	$V_S = 13.5\text{ V}$	PRQ-212

CLS

Maximum time in CLS mode	t_{CLS}	–	–	100	ms	²⁾ See Figure 21	PRQ-872
Maximum number of CLS mode activations	n_{CLS_ACT}	–	–	50	kcycles	²⁾ See Figure 21	PRQ-873
Thermal shut down temperature in CLS (dynamic)	$T_{J_CLS(DYN)}$	–	30	–	K	²⁾	PRQ-1432

Output characteristics

ON-state resistance at $T_J = 25^\circ\text{C}$	$R_{DS(ON)_25}$	–	18.0	–	m Ω	²⁾ $T_J = 25^\circ\text{C}$	PRQ-1010
ON-state resistance at $T_J = 150^\circ\text{C}$	$R_{DS(ON)_150}$	–	–	33.0	m Ω	$T_J = 150^\circ\text{C}$	PRQ-1011
ON-state resistance in cranking	$R_{DS(ON)_CRANK}$	–	–	37.5	m Ω	$T_J = 150^\circ\text{C}$ $V_S = 3.1\text{ V}$	PRQ-1012

(table continues...)

Table 10 (continued) Electrical characteristics power stages
 $V_S = 5\text{ V to }20\text{ V}$, $T_J = -40^\circ\text{C to }+150^\circ\text{C}$

 Unless otherwise specified typical values: $V_S = 13.5\text{ V}$, $T_J = 25^\circ\text{C}$

 Typical resistive loads connected to the outputs for testing (unless otherwise specified): $R_L = 2.1\ \Omega$

Parameter	Symbol	Values			Unit	Note or condition	P-Number
		Min.	Typ.	Max.			
ON-state resistance in idle mode at $T_J = 150^\circ\text{C}$	$R_{DS(ON_IDLE)}$	–	37.5	–	m Ω	$T_J = 150^\circ\text{C}$	PRQ-1013
ON-state resistance in inverse current at $T_J = 25^\circ\text{C}$	$R_{DS(INV_25)}$	–	18.5	–	m Ω	2) $T_J = 25^\circ\text{C}$ $V_S = 13.5\text{ V}$ $I_L = -4\text{ A}$ DEN = "low" See Figure 24	PRQ-1014
ON-state resistance in inverse current at $T_J = 150^\circ\text{C}$	$R_{DS(INV_150)}$	–	–	37.5	m Ω	$T_J = 150^\circ\text{C}$ $V_S = 13.5\text{ V}$ $I_L = -4\text{ A}$ DEN = "low" See Figure 24	PRQ-1015
ON-state resistance in reverse polarity at $T_J = 25^\circ\text{C}$	$R_{DS(REV_25)}$	–	37.5	–	m Ω	2) $T_J = 25^\circ\text{C}$ $V_S = -13.5\text{ V}$ $I_L = -4\text{ A}$ See Figure 34	PRQ-1016
ON-state resistance in reverse polarity at $T_J = 150^\circ\text{C}$	$R_{DS(REV_150)}$	–	–	50.5	m Ω	2) $T_J = 150^\circ\text{C}$ $V_S = -13.5\text{ V}$ $I_L = -4\text{ A}$	PRQ-1017
Nominal load current	$I_{L(NOM)_85}$	–	6.8	–	A	2) $T_A = 85^\circ\text{C}$ $T_J \leq 150^\circ\text{C}$	PRQ-1018
Output leakage current at $T_J \leq 85^\circ\text{C}$	$I_{L(OFF)_85}$	–	0.03	0.2	μA	2) $V_{OUT} = 0\text{ V}$ $V_{IN} = \text{"low"}$ $T_J \leq 85^\circ\text{C}$	PRQ-1019
Output leakage current at $T_J = 150^\circ\text{C}$	$I_{L(OFF)_150}$	–	–	5	μA	$V_{OUT} = 0\text{ V}$ $V_{IN} = \text{"low"}$ $T_J = 150^\circ\text{C}$	PRQ-1020

(table continues...)

Table 10 (continued) Electrical characteristics power stages

$V_S = 5\text{ V to }20\text{ V}$, $T_J = -40^\circ\text{C to }+150^\circ\text{C}$

Unless otherwise specified typical values: $V_S = 13.5\text{ V}$, $T_J = 25^\circ\text{C}$

Typical resistive loads connected to the outputs for testing (unless otherwise specified): $R_L = 2.1\ \Omega$

Parameter	Symbol	Values			Unit	Note or condition	P-Number
		Min.	Typ.	Max.			
Inverse current capability	$I_{L(INV)}$	–	-6.8	–	A	2) $V_S < V_{OUT}$ IN = "high" See Figure 24	PRQ-1021

Voltages

Drain source diode voltage	$ V_{DS(DIODE)} $	–	550	700	mV	$I_L = -190\text{ mA}$ $T_J = 150^\circ\text{C}$	PRQ-224
----------------------------	-------------------	---	-----	-----	----	---	---------

Switching energy

Switch-ON energy	E_{ON}	–	1.5	–	mJ	2) $V_S = 20\text{ V}$ See Figure 19	PRQ-225
Switch-OFF energy	E_{OFF}	–	1.65	–	mJ	2) $V_S = 20\text{ V}$ See Figure 19	PRQ-226

1) Tested at $T_J = 150^\circ\text{C}$.

2) Not subject to production test - specified by design.

8 Device protection

The device is protected against overtemperature, overcurrent, reverse battery (with Reverse ON) and overvoltage. Overtemperature and overcurrent protections are disabled when the device is in sleep mode.

When the device is in idle mode the overtemperature protection is disabled and the overcurrent protection is enabled.

Overtemperature and overcurrent protections are not active during inverse current and in reverse battery condition.

Overvoltage protection works in all operation modes.

Reverse battery protection works when the GND and VS pins are reverse supplied.

8.1 Overtemperature protection

The device incorporates an absolute ($T_{J(ABS)}$) as well as a dynamic ($T_{J(DYN)}$) temperature protection circuitry for the channel.

An increase of junction temperature T_J above either one of the two thresholds ($T_{J(ABS)}$ or $T_{J(DYN)}$) switches OFF the overheated channel to prevent destruction. The channel remains switched OFF until the junction temperature has reached the “reactivation” condition and a reset was applied as described in [Table 11](#). The behavior is shown in [Figure 25](#) and [Figure 26](#). $T_{J(REF)}$ is the reference temperature used for dynamic temperature protection.

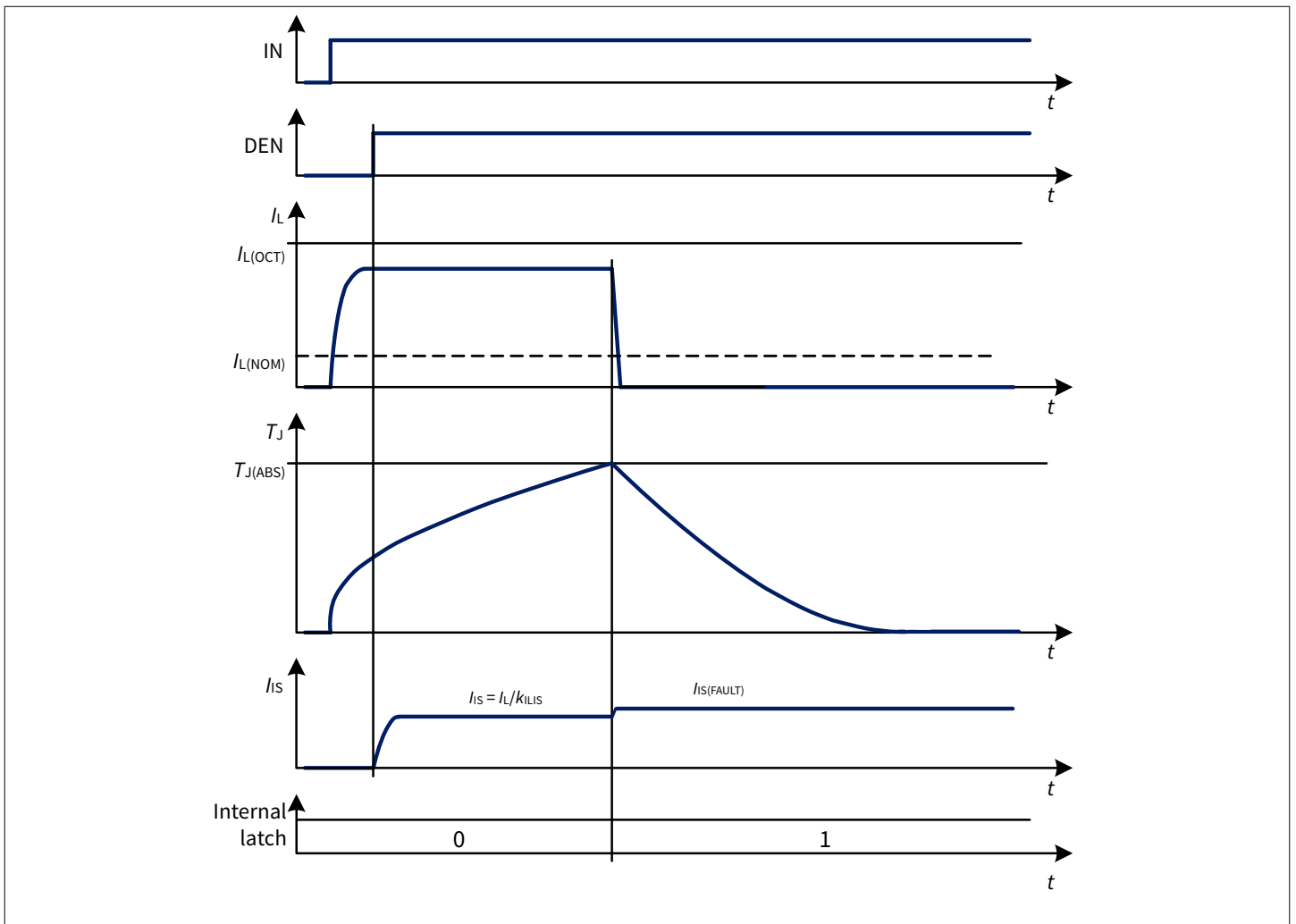

Figure 25 Overtemperature protection (absolute)

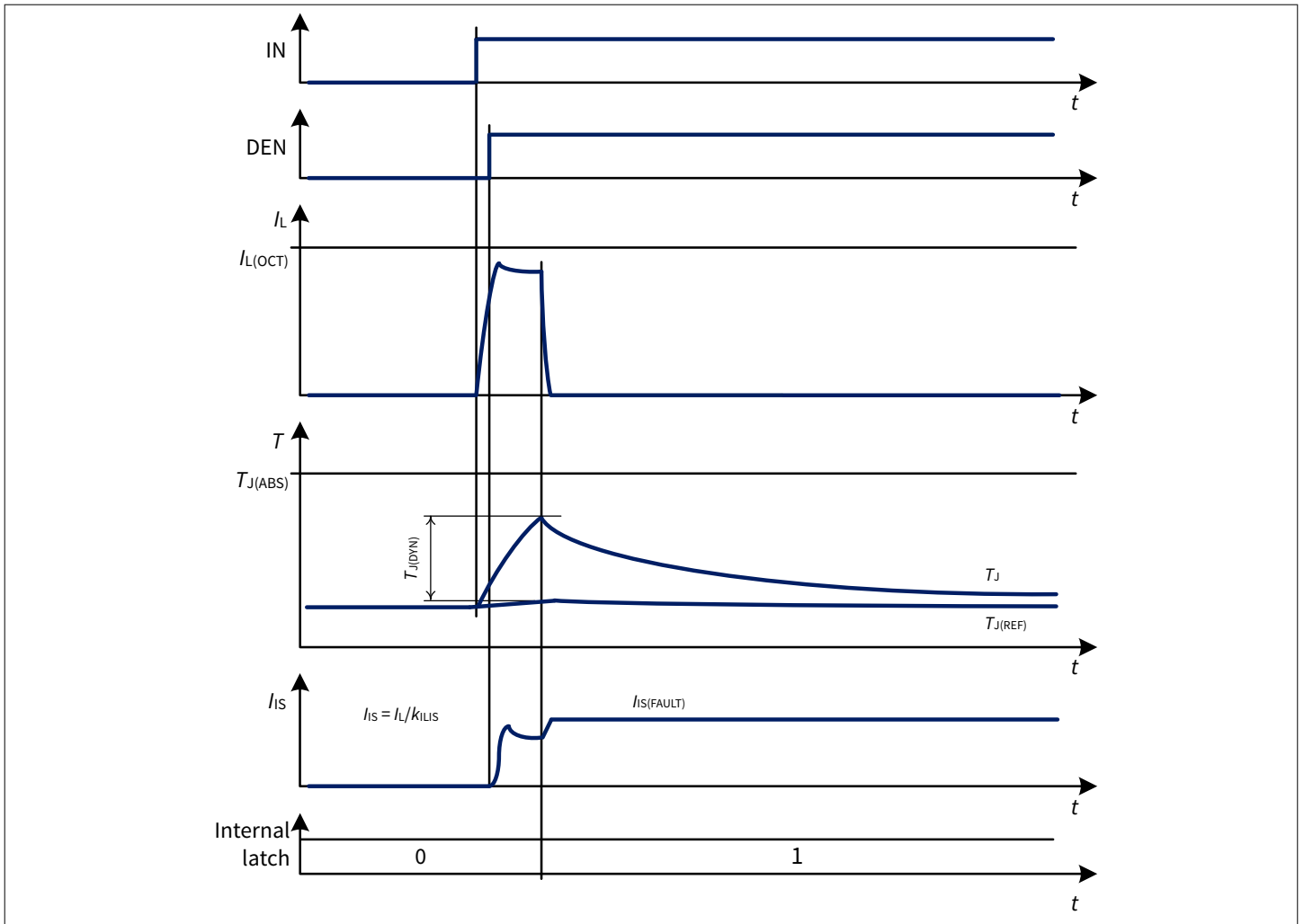

Figure 26 Overtemperature protection (dynamic)

When the overtemperature protection circuitry allows the channel to be switched ON again, the intelligent latch strategy described in [Chapter 8.3](#) is followed.

8.2 Overcurrent threshold protection

The device is protected in case of overload or short circuit to ground by the overcurrent protection $I_{L(OCT)}$.

Furthermore, the overcurrent threshold $I_{L(OCT)}$ can be adjusted from the lowest configurable overcurrent detection threshold $I_{L(LOCT)}$ to the highest configurable overcurrent detection threshold $I_{L(HOCT)}$ by connecting a resistor between the OCT pin and the GND pin of the device. The adjustment of the overcurrent threshold (without considering the V_{DS} reduction) could be done according to formula:

$$I_{L(OCT)_TJ} [A] = [(I_{OCT}[\mu A] - 7.5[\mu A]) \cdot k_{OCT}[A/\mu A] + I_{L(LOCT)_-40}[A]] \cdot [(T_J[^\circ C] + 40[^\circ C]) \cdot k_{TJ} \cdot 10^{-3} + 1]$$

(2)

To select the proper resistor value R_{OCT} connected between the OCT pin and device ground, the following equation can be considered:

$$I_{OCT} = \frac{V_{OCT}}{R_{OCT}} \quad (3)$$

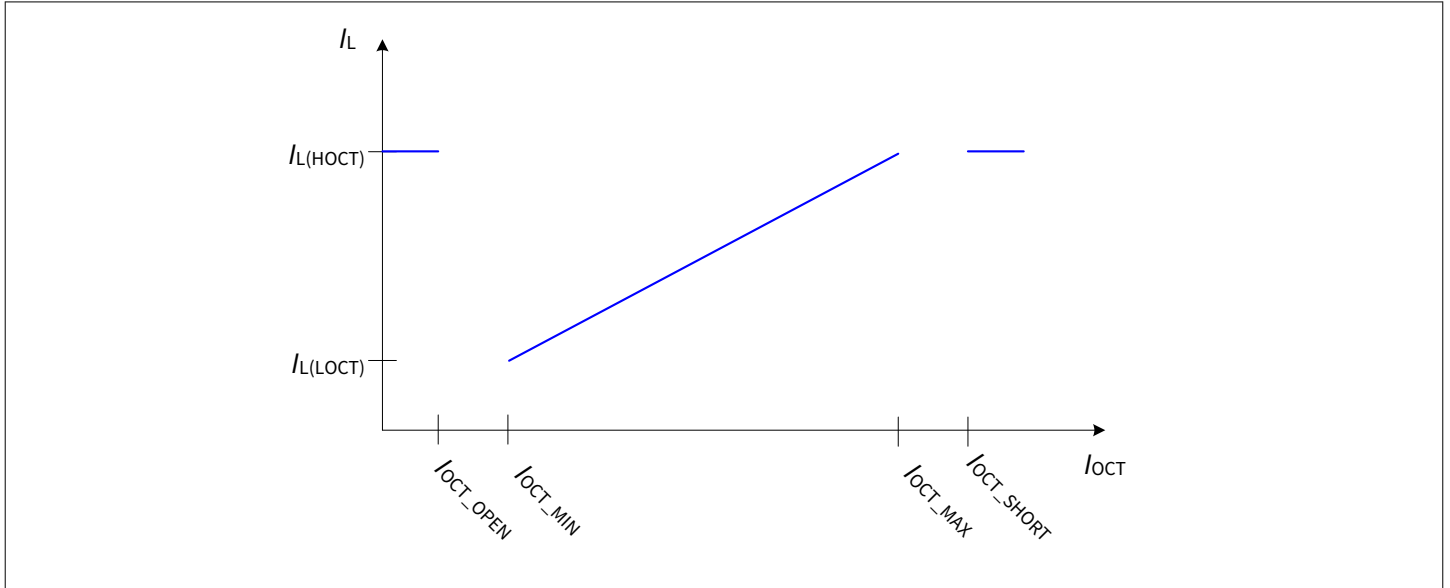

Figure 27 Overcurrent threshold adjustment by I_{OCT}

In case of an open or short detection of the OCT adjustment current I_{OCT} at the pin the device changes to the highest configurable overcurrent detection threshold $I_{L(HOCT)}$.

The overcurrent thresholds are depending on the voltage V_{DS} across the power DMOS.

If an overcurrent threshold adjustment current $I_{OCT} < 30 \mu A$ (Typical value) is selected no reduction of the $I_{L(OCT)}$ over V_{DS} takes place (see Figure 28).

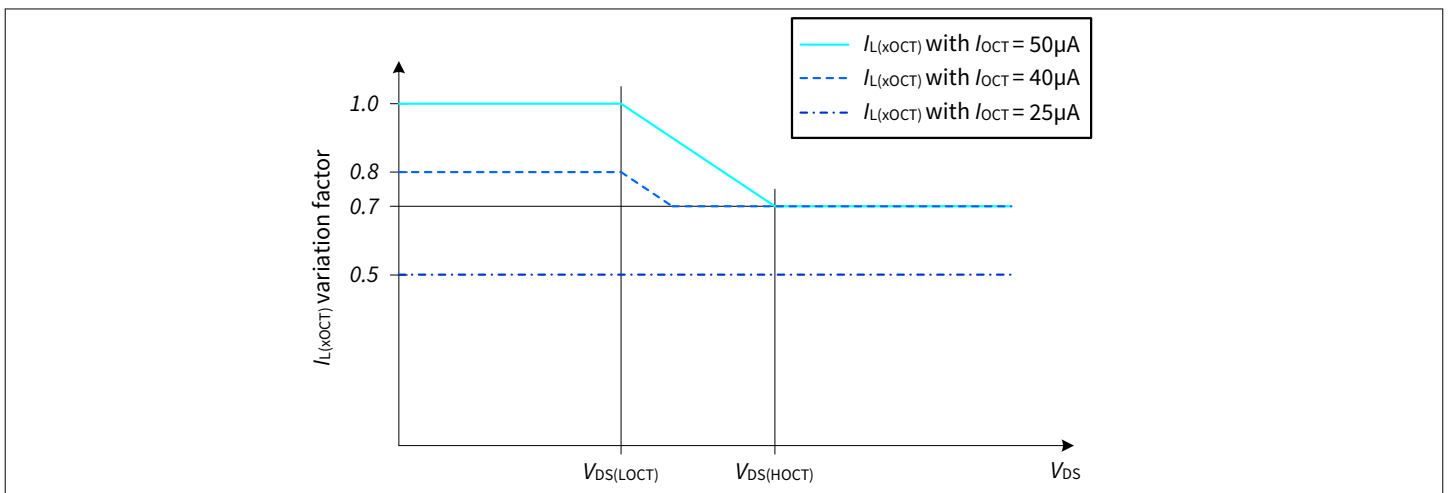

Figure 28 Adjustable overcurrent threshold variation with V_{DS}

In order to allow a higher load inrush current at low ambient temperature, the overcurrent threshold is maximum at low temperature and decreases when T_j increases (see Figure 29).

Overcurrent detection threshold decreases linearly with increasing temperature.

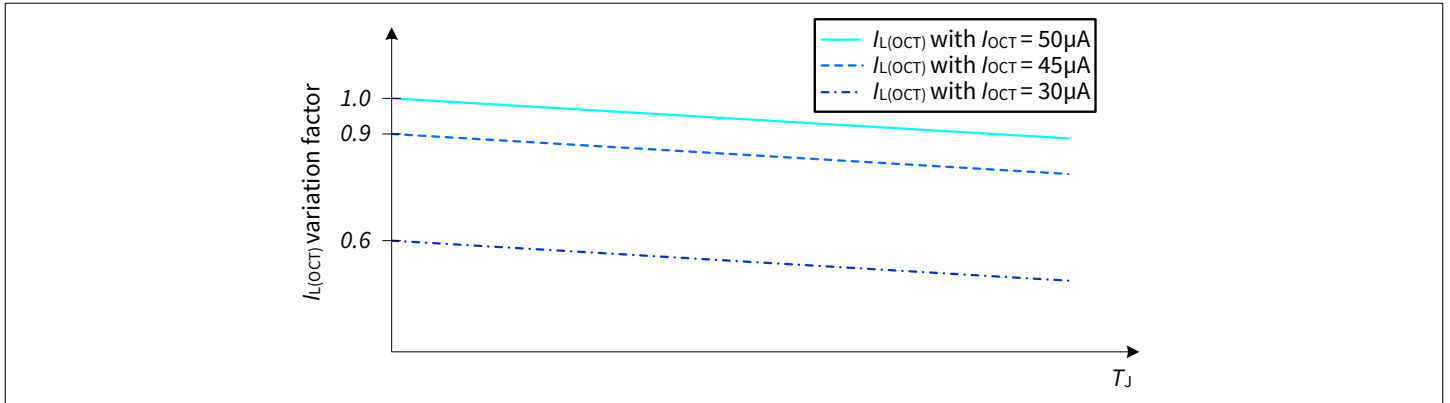

Figure 29 Adjustable overcurrent threshold variation with T_J

Power supply voltage V_S can increase above 18 V for short time, for instance in load dump or in jump start condition. Whenever $V_S \geq V_{S(JS)}$ during switch ON, the overcurrent detection current is set to $I_{L(OCT_JS)}$.

If an overcurrent threshold adjustment current $I_{OCT} < 30 \mu A$ (Typical value) is selected no reduction of the $I_{L(OCT)}$ with V_S takes place (see Figure 30).

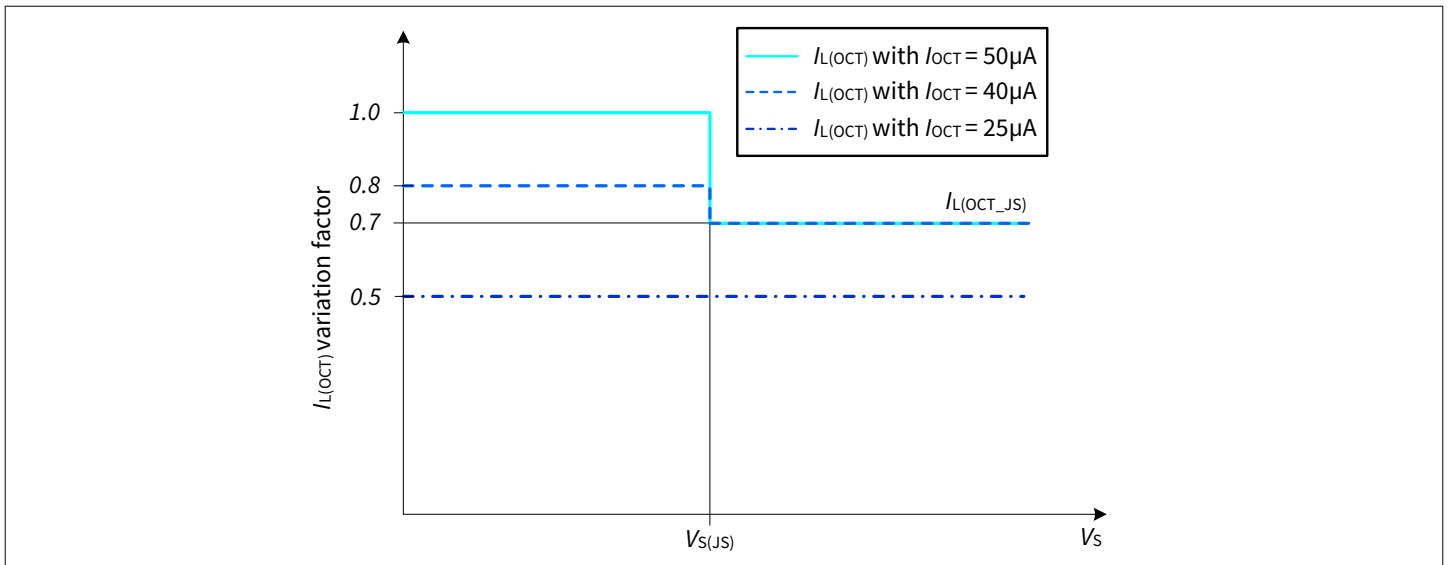

Figure 30 Adjustable overcurrent with V_S voltage

When $I_L \geq I_{L(OCT)}$ the channel is switched OFF. The channel is allowed to be reactivated according to the intelligent latch strategy described in Chapter 8.3.

8.3 Device protection and diagnosis in case of fault

Any fault event (either overtemperature or overcurrent) that triggers a device protection mechanism has two consequences:

- The channel switches OFF and remains latched OFF (internal latch set to "1")
- If the sequential diagnosis is active for the channel, the current $I_{IS(FAULT)}$ is provided in case of IN = "high" (see [Chapter 10.1.1](#)) and for IN = "low" the current $I_{IS(DEVOFF)}$ is provided at address #1 (see [Chapter 10.1.2](#) for further details)

The channel can be switched ON again if all the protection mechanisms fulfill the "reactivation" conditions described in [Table 11](#) and a reset by DEN or IN was applied.

Furthermore, the device has the intelligent latch to protect itself against unwanted repetitive reactivation in fault condition.

Table 11 Protection "reactivation" condition

Fault condition	Switch OFF event	"Reactivation" condition
Overtemperature	$T_J \geq T_{J(ABS)}$ or $(T_J - T_{J(REF)}) \geq T_{J(DYN)}$	$T_J < T_{J(ABS)}$ and $(T_J - T_{J(REF)}) < T_{J(DYN)}$ (including hysteresis)
Overcurrent	$I_L \geq I_{L(OCT)}$	

8.3.1 Intelligent latch reset strategy after device protection triggered

In normal condition, when IN is set to "high", the channel is switched ON. In case the device protection is triggered, the output stage is switched OFF. It remains OFF until the channel is reset. There are two ways to reset the channel:

With IN pin: By setting the input pin to "low" for a time longer than $t_{DELAY(LR)}$ ("latch reset delay" time), the channel is reset if the "reactivation" conditions for the protection mechanisms are fulfilled (see [Table 11](#)). If the input is set to "high" during the "latch reset delay" time the channel remains switched OFF and the timer $t_{DELAY(LR)}$ is reset. The timer $t_{DELAY(LR)}$ restarts as soon as the input pin is set to "low" again.

With DEN pin: It is possible to "force" a reset of the internal latch without waiting for $t_{DELAY(LR)}$ by applying a pulse (rising edge followed by a falling edge) to the DEN pin while IN pin is "low". The pulse applied to DEN pin must have a duration longer than $t_{DEN(LR)}$ to ensure a reset of the internal latch.

Intelligent latch reset strategy after device protection triggered is shown in [Figure 31](#), [Figure 32](#) and [Figure 33](#).

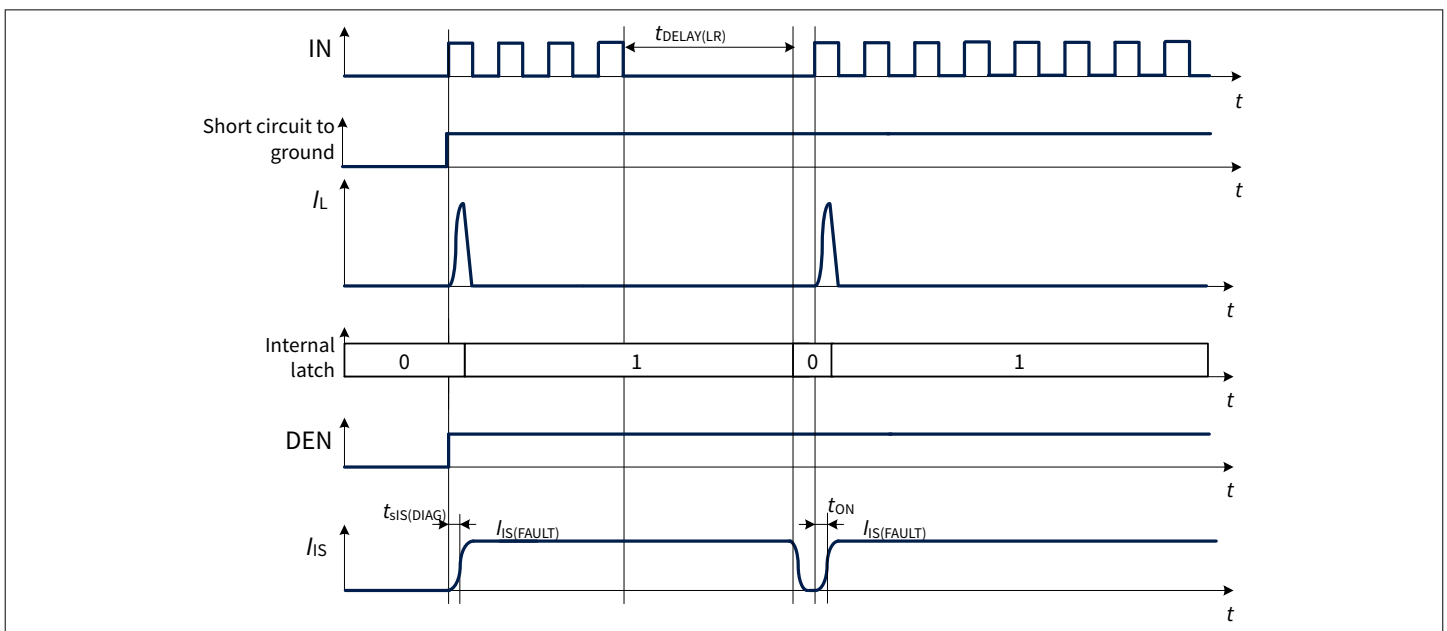

Figure 31 Intelligent latch timing diagram for IN reset in case of triggered device protection

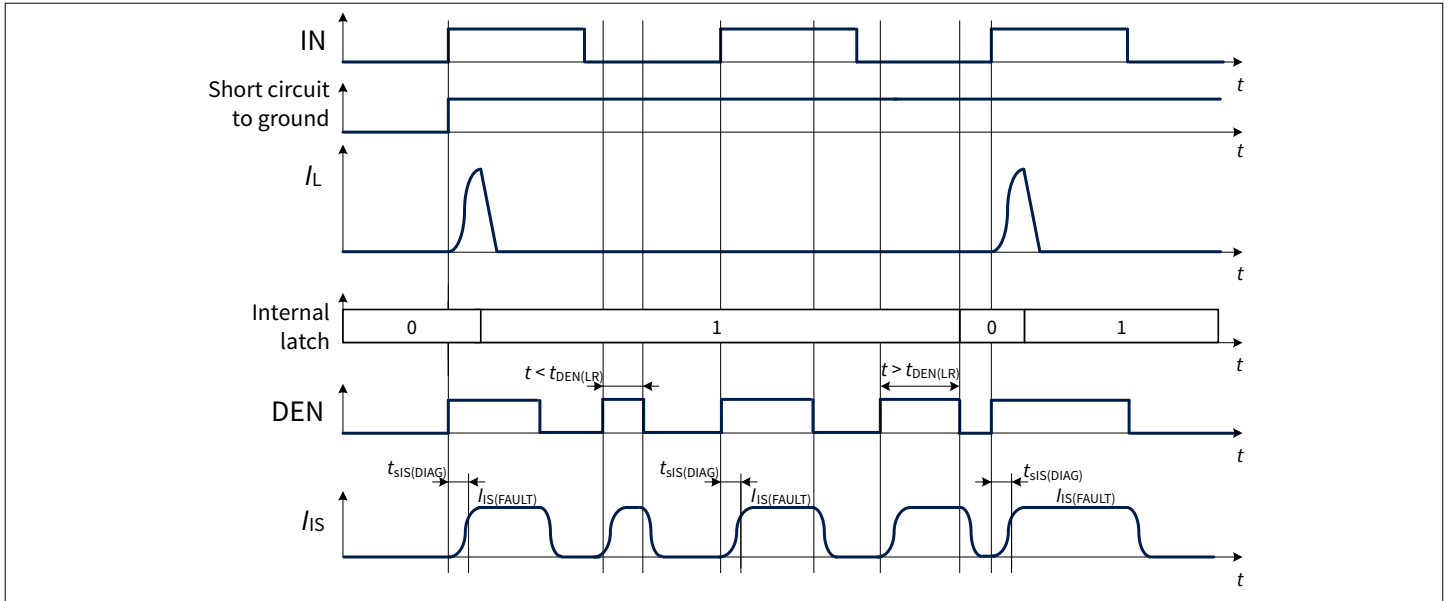

Figure 32 Intelligent latch timing diagram for DEN reset in case of triggered device protection

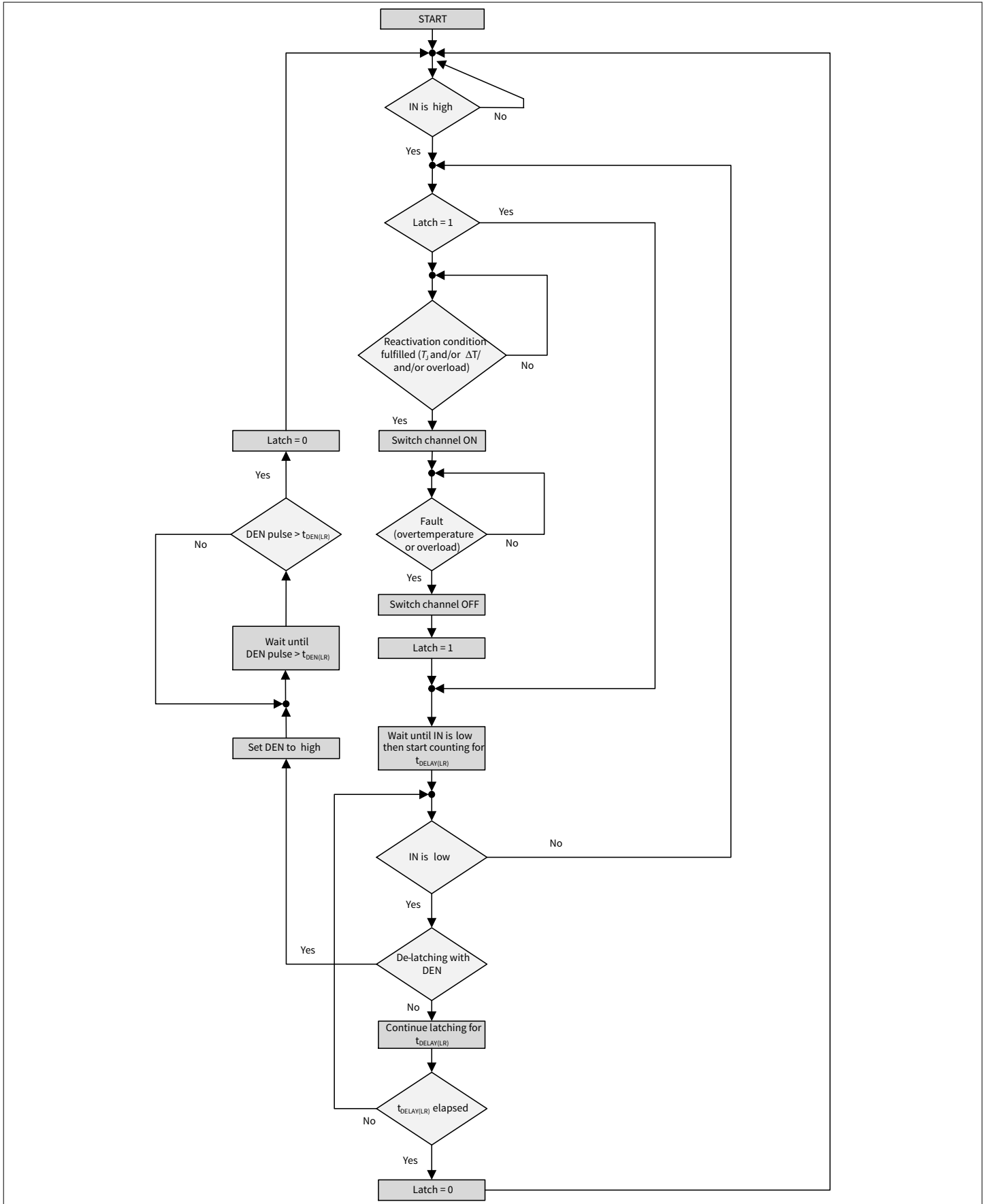

Figure 33 Intelligent latch flowchart in case of triggered device protection

8.4 Additional protections

8.4.1 Reverse polarity protection

In reverse polarity condition (also known as reverse battery), the output stage is switched ON (see parameter $R_{DS(REV)}$) because of the Reverse ON feature, which limits the power dissipation in the output stage. Each ESD diode of the logic contributes to total power dissipation. The reverse current through the output stage must be limited by the connected load. The current through digital input pins has to be limited as well by an external resistor (please refer to the absolute maximum ratings listed in [Table 2](#) and to application information in [Chapter 11](#)). [Figure 34](#) shows a typical application including a device with Reverse ON. A current flowing into GND pin ($-I_{GND}$) during reverse polarity condition is necessary to activate Reverse ON, therefore a resistive path between module ground and device GND pin must be present.

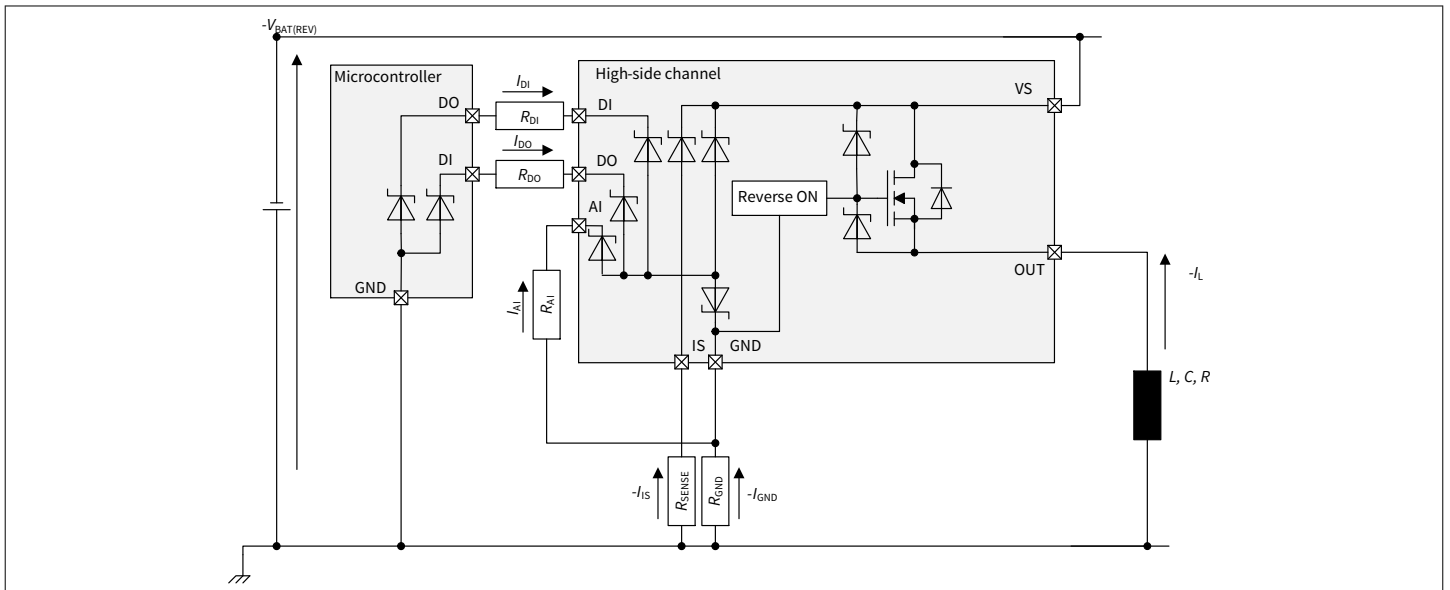

Figure 34 Reverse battery protection (application example)

8.4.2 Overvoltage protection

In case of supply voltages between $V_{S(EXT,UP)}$ and $V_{BAT(LD)}$, the output transistor is still operational and follows the input pin.

In addition to the output clamp for inductive loads as described in [Chapter 7.2.2](#), there is a clamp mechanism available for overvoltage protection for the logic circuit and the output channels, monitoring the voltage between VS and GND pins ($V_{S(CLAMP)}$).

8.5 Protection against loss of connection

8.5.1 Loss of battery and loss of load

The loss of connection to battery or load has no influence on device robustness when load and wire harness are purely resistive. In case of driving an inductive load, the energy stored in the inductance must be handled.

PROFET™ Wire Guard devices handle the inductivity of the wire harness up to 10 μH with $I_{L(NOM)}_{85}$.

In case of applications where currents and / or the aforementioned inductivity are exceeded, an external suppressor diode (like diode D_{Z2} shown in [Chapter 11](#)) is recommended to handle the energy and to provide a well-defined path to the load current.

8.5.2 Loss of ground

In case of loss of device ground, it is recommended to have a resistor connected between any digital input pin and the microcontroller to ensure a channel switch OFF (as described in [Chapter 11](#)).

Note: *In case that any digital input pin is pulled to ground (either by a resistor or active) a parasitic ground path is available, which could keep the device operational during loss of device ground.*

8.6 Electrical characteristics device protection

Table 12 Electrical characteristics device protection

$V_S = 5\text{ V to }20\text{ V}$, $T_J = -40^\circ\text{C to }+150^\circ\text{C}$

Unless otherwise specified typical values: $V_S = 13.5\text{ V}$, $T_J = 25^\circ\text{C}$

Typical resistive loads connected to the outputs for testing (unless otherwise specified): $R_L = 2.1\ \Omega$

Parameter	Symbol	Values			Unit	Note or condition	P-Number
		Min.	Typ.	Max.			
Thermal							
Thermal shutdown temperature (absolute)	$T_{J(ABS)}$	150	175	200	$^\circ\text{C}$	^{1) 2)} See Figure 25	PRQ-246
Thermal shutdown hysteresis (absolute)	$T_{HYS(ABS)}$	–	30	–	K	³⁾	PRQ-247
Thermal shutdown temperature (dynamic)	$T_{J(DYN)}$	–	80	–	K	³⁾ See Figure 26	PRQ-248
Voltages							
Power supply clamping voltage at $T_J = -40^\circ\text{C}$	$V_{S(CLAMP)_{-40}}$	33	36.5	42	V	$I_{VS} = 10\text{ mA}$ $T_J = -40^\circ\text{C}$ See Figure 20	PRQ-251
Power supply clamping voltage at $T_J \geq 25^\circ\text{C}$	$V_{S(CLAMP)_{25}}$	35	38	44	V	²⁾ $I_{VS} = 10\text{ mA}$ $T_J \geq 25^\circ\text{C}$ See Figure 20	PRQ-252
Low level of overcurrent threshold depending on drain source voltage	$V_{DS(LOCT)}$	13.5	15.0	16.5	V	³⁾	PRQ-1248
High level of overcurrent threshold depending on drain source voltage	$V_{DS(HOCT)}$	18	20	22	V	³⁾	PRQ-1249

(table continues...)

Table 12 (continued) Electrical characteristics device protection
 $V_S = 5\text{ V to }20\text{ V}, T_J = -40^\circ\text{C to }+150^\circ\text{C}$

 Unless otherwise specified typical values: $V_S = 13.5\text{ V}, T_J = 25^\circ\text{C}$

 Typical resistive loads connected to the outputs for testing (unless otherwise specified): $R_L = 2.1\ \Omega$

Parameter	Symbol	Values			Unit	Note or condition	P-Number
		Min.	Typ.	Max.			
Power supply voltage threshold for overcurrent threshold reduction in case of short circuit	$V_{S(JS)}$	20.5	22.5	24.5	V	³⁾ Setup acc. to AEC-Q100-012	PRQ-253

Timings

Latch reset delay time after fault condition	$t_{\text{DELAY(LR)}}$	40	70	100	ms	¹⁾ See Figure 31	PRQ-254
Minimum DEN pulse duration for latch reset	$t_{\text{DEN(LR)}}$	50	100	150	μs	³⁾ See Figure 32	PRQ-255

1) Functional test only.

 2) Tested at $T_J = 150^\circ\text{C}$ only.

3) Not subject to production test - specified by design.

Table 13 Electrical characteristics protection - power output stages
 $V_S = 5\text{ V to }20\text{ V}, T_J = -40^\circ\text{C to }+150^\circ\text{C}$

 Unless otherwise specified typical values: $V_S = 13.5\text{ V}, T_J = 25^\circ\text{C}$

 Typical resistive loads connected to the outputs for testing (unless otherwise specified): $R_L = 2.1\ \Omega$

Parameter	Symbol	Values			Unit	Note or condition	P-Number
		Min.	Typ.	Max.			
Highest configurable overcurrent detection threshold at $T_J = -40^\circ\text{C}$	$I_{L(\text{HOCT})_{-40}}$	36	43	50	A	¹⁾ $T_J = -40^\circ\text{C}$ $dI/dt = 0.1\text{ A}/\mu\text{s}$ $I_{\text{OCT}} = 50\ \mu\text{A}$	PRQ-1022
Highest configurable overcurrent detection threshold at $T_J = 25^\circ\text{C}$	$I_{L(\text{HOCT})_{25}}$	35.5	41.0	47.0	A	^{1) 2)} $T_J = 25^\circ\text{C}$ $dI/dt = 0.1\text{ A}/\mu\text{s}$ $I_{\text{OCT}} = 50\ \mu\text{A}$	PRQ-1023
Highest configurable overcurrent detection threshold at $T_J = 150^\circ\text{C}$	$I_{L(\text{HOCT})_{150}}$	30.5	36.0	41.0	A	^{1) 2)} $T_J = 150^\circ\text{C}$ $dI/dt = 0.1\text{ A}/\mu\text{s}$ $I_{\text{OCT}} = 50\ \mu\text{A}$	PRQ-1024

(table continues...)

Table 13 (continued) Electrical characteristics protection - power output stages
 $V_S = 5\text{ V to }20\text{ V}$, $T_J = -40\text{ °C to }+150\text{ °C}$

 Unless otherwise specified typical values: $V_S = 13.5\text{ V}$, $T_J = 25\text{ °C}$

 Typical resistive loads connected to the outputs for testing (unless otherwise specified): $R_L = 2.1\ \Omega$

Parameter	Symbol	Values			Unit	Note or condition	P-Number
		Min.	Typ.	Max.			
Overcurrent detection at high VDS	$I_{L(OCT_VDS)}$	–	25	–	A	1) 2) $I_{OCT} = 50\ \mu\text{A}$ $V_{DS} > V_{DS(HOCT)}$ See Figure 28	PRQ-1025
Overcurrent detection - jump start condition	$I_{L(OCT_JS)}$	–	25	–	A	1) 2) $V_S > V_{S(JS)}$ $I_{OCT} = 50\ \mu\text{A}$ See Figure 30	PRQ-1026
Lowest configurable overcurrent detection threshold	$I_{L(OCT)_-40}$	4	9	12	A	1) $T_J = -40\text{ °C}$ $dI/dt = 0.025\text{ A}/\mu\text{s}$ $I_{OCT} = 7.5\ \mu\text{A}$	PRQ-1028
Overcurrent threshold ratio at $T_J = -40\text{ °C}$	k_{OCT}	–	0.800	–	–	2) $T_J = -40\text{ °C}$	PRQ-1317
OCT current threshold for short detection	I_{OCT_SHORT}	83.3	–	–	μA	–	PRQ-885
OCT adjustment current	I_{OCT}	7.2	–	52.6	μA	–	PRQ-599
OCT current threshold for open detection	I_{OCT_OPEN}	–	–	3.8	μA	–	PRQ-886
Overcurrent threshold temperature coefficient	k_{TJ}	–	-0.857	–	–	2)	PRQ-1498

1) Functional test only.

2) Not subject to production test - specified by design.

9 System protection

9.1 I2t protection

The integrated I2t protection supports the protection of the system including the wire harness and the PCB traces.

The I2t protection function is active in I2t mode and I2t with diagnosis mode. While the I2t status calculation (with $I_L = 0$ A) is as well present in Inactive mode, Inactive with diagnosis mode, CLS mode and CLS with diagnosis mode.

The I2t protection feature calculates an I2t status S_{I2t} , which is based on the load current I_L , the time constant of all I2t protection curves τ_{I2t} and the dedicated IDC of the I2t protection curve $I_{L(I2t_x)}$.

The channel is switched off as soon as the I2t status S_{I2t} calculation reaches 100% (see Figure 35).

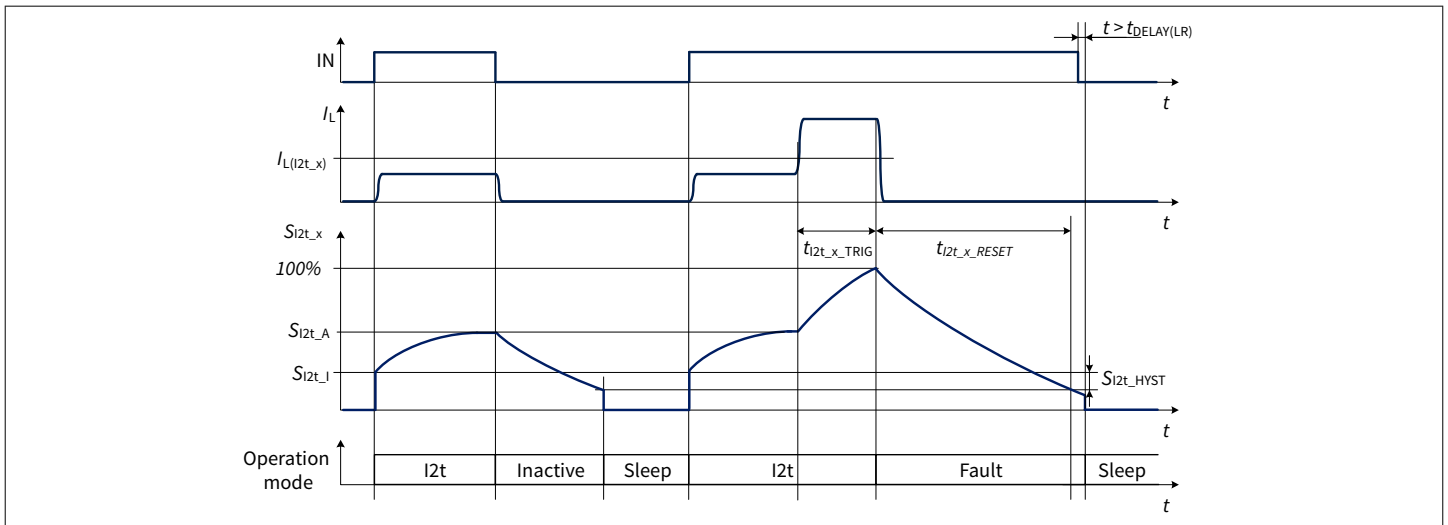

Figure 35 I2t protection timing

When the power stage is switched off due to an I2t protection event, the channel is latched off and the I2t status is further calculated with $I_L = 0$ A.

The dedicated trigger time of the I2t protection curve depends on the actual I2t status S_{I2t_A} and can be calculated for constant load currents by:

$$t_{I2t_x_TRIG} = \begin{cases} \infty & \text{for } I_L \leq I_{L(I2t_x)} \\ \tau_{I2t} \cdot \ln \left(\frac{I_L^2 - I_{L(I2t_x)}^2 \cdot S_{I2t_A}}{I_L^2 - I_{L(I2t_x)}^2} \right) & \text{for constant } I_L > I_{L(I2t_x)} \end{cases} \quad (4)$$

The steady state value of the actual I2t status S_{I2t_A} can be calculated with the actual steady state current I_{L_A} by:

$$S_{I2t_A} = \frac{I_{L_A}^2}{I_{L(I2t_x)}^2} \quad (5)$$

The initial value of the I2t status calculation depends on the mode transition and the actual I2t status S_{I2t_A} . In case the I2t status calculation is resumed from a value lower than the initial status S_{I2t_I} minus the I2t status hysteresis S_{I2t_HYST} (for instance the I2t mode is entered for the first time) the I2t calculation is pre-loaded with the initial status value S_{I2t_I} . In case the I2t status calculation is resumed from a value higher than the initial status S_{I2t_I} minus the I2t status hysteresis S_{I2t_HYST} , the I2t status S_{I2t} calculation will be resumed from the actual I2t status S_{I2t_A} .

The initial status value S_{I2t_I} is preloaded for the following transition conditions slp_i2t, slp_iwd, idle_i2t, idle_ina, awd_i2twd and awd_iwd (see Figure 16). In all other transition conditions, the I2t status calculation is resumed from the actual S_{I2t_A} value.

In case the actual I2t status S_{I2t_A} is preloaded by the initial I2t status S_{I2t_I} it has to be replaced in equation 3 (dedicated trigger time of the I2t protection curve) by the initial I2t status S_{I2t_I} which can be calculated by:

$$S_{I2t_I} = \frac{I_{L(I2t_I)}^2}{I_{L(I2t_x)}^2} \quad (6)$$

To enter sleep mode after the I2t protection feature was triggered the I2t status calculation has to be below the initial status S_{I2t_I} minus the I2t status hysteresis S_{I2t_HYST} (see Figure 35). This transition time $t_{I2t_x_RESET}$ is given by the following formula (assuming $I_L = 0$ A):

$$t_{I2t_x_RESET} = \tau_{I2t} \cdot \ln \left(\frac{I_{L(I2t_x)}^2}{(I_{L(I2t_I)} - I_{L(I2t_HYST)})^2} \right) \quad (7)$$

As the ambient temperature and the PCB layout influences the thermal behavior of the device, the overtemperature protection might be triggered before $t_{I2t_x_TRIG}$ is reached (see Figure 36). Therefore, the maximum time for a given current is potentially limited by the thermal design of the component. For more information, refer to Table 5.

The device has six different I2t protection curves $I_{L(I2t_x)}$ implemented (see Figure 36). The I2t protection curves $I_{L(I2t_x)}$ can be selected by placing the corresponding selection resistor R_{I2t_x} . The resistor must be connected between the I2t pin and the ground pin of the device. See Table 14 for detailed information. In case of an open or short of the selection resistor the device selects the I2t protection curve 1.

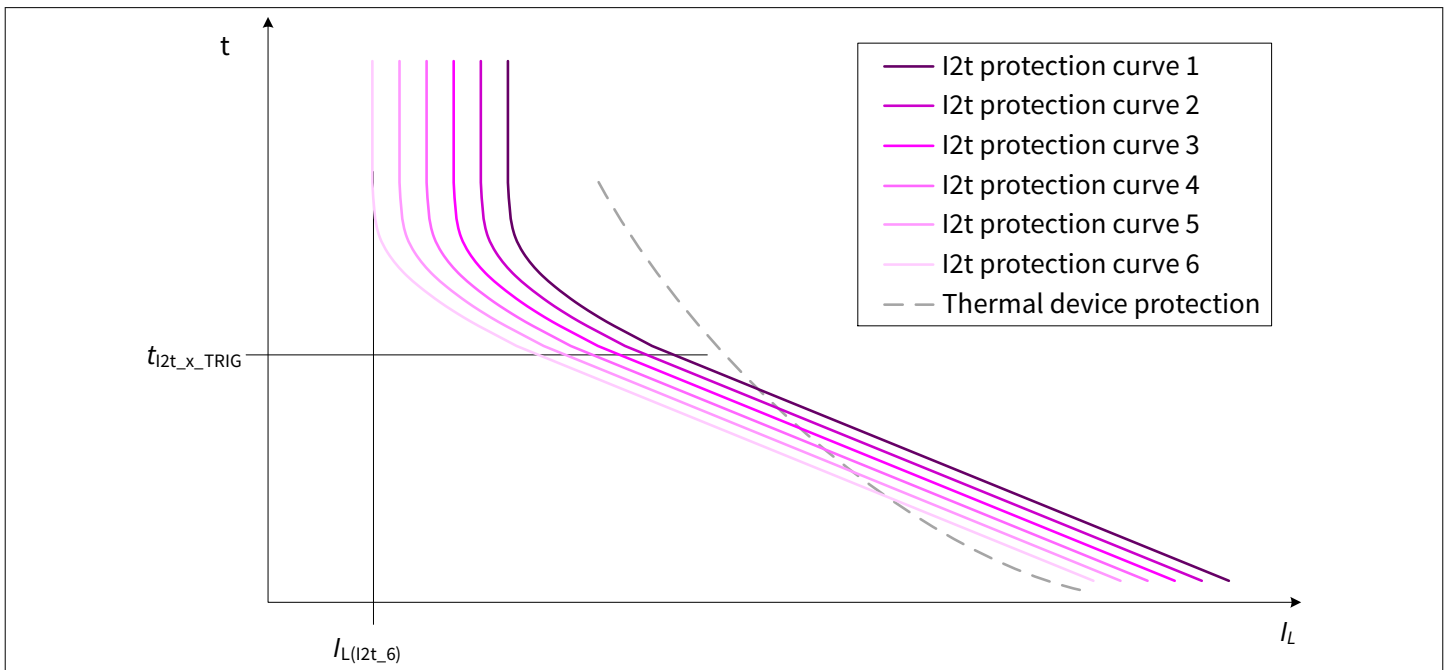

Figure 36 Energy graph of I2t protection curves

Note: This is a very simplified overview of the implemented system protection function. For detailed trigger behavior, refer to Table 14.

The synchronization time $t_{SYNC(RI2t)}$ for I2t programming resistor setting is a time at which the device internally updates the I2t protection curve setting.

During inverse current operation the I2t calculation assumes no load current flowing.

In reverse battery condition the I2t calculation is reset and disabled.

9.1.1 I2t protection and idle mode

In idle mode as well as in active with diagnosis mode, the I2t protection calculation is disabled. To change from I2t mode to idle mode the idle mode entry conditions have to be fulfilled (see [Chapter 6.1.7](#)). The minimum transition time from I2t mode to idle mode for $I_L = 0$ A could be calculated by:

$$t_{T(I2t_IDLE)} = \tau_{I2t} \cdot \ln \left(\frac{I_{L(I2t_I)}^2}{(I_{L(I2t_I)} - I_{L(I2t_HYST)})^2} \right) \quad (8)$$

When the device changes from idle mode into I2t mode, I2t with diagnosis mode (over active with diagnosis mode) and inactive mode, the initial value of the I2t status calculation becomes again pre-loaded with the initial current for I2t protection value $I_{L(I2t_I)}$ (see [Figure 37](#)).

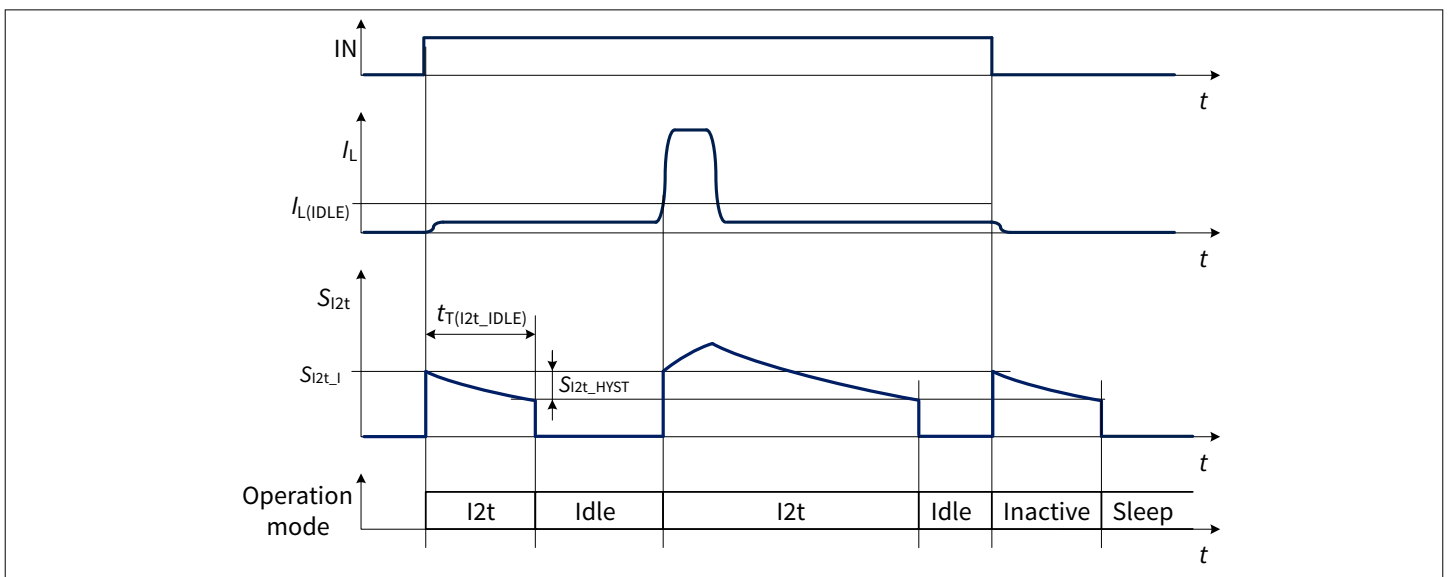

Figure 37 Idle mode timing

9.1.2 Intelligent latch reset strategy after I2t protection triggered

Any fault event that triggers the I2t protection mechanism has the following consequences:

- The channel switches OFF and remains latched OFF (internal latch set to "1")
- The calculation of I2t protection curve will be continued
- If the diagnosis is active for the channel, depending on the sequential diagnosis address and IN status, different I_{IS} currents are provided at the IS pin (for further details see [Figure 44](#))
 - Address #1 & IN = "high" - the $I_{IS(FAULT)}$ current is provided showing that the channel is switched OFF
 - Address #1 & IN = "low" - the $I_{IS(I2tOFF)}$ current is provided showing that the channel is switched OFF due to triggered I2t protection
 - Address #2 - #5 & IN = "low" - the I_{IS} currents are provided as described in [Figure 44](#)

The intelligent latch can be reset by IN or DEN at any time of the I2t status calculation. After the reset the channel can be switched ON again and the I2t status will be further calculated.

With IN pin: By setting the input pin to "low" for a time longer than $t_{DELAY(LR)}$ ("latch reset delay" time) the channel is reset. If the input is set to "high" during the "latch reset delay" time, the channel remains switched OFF and the timer $t_{DELAY(LR)}$ is reset. The timer $t_{DELAY(LR)}$ restarts as soon as the input pin is set to "low" again (see [Figure 38](#)).

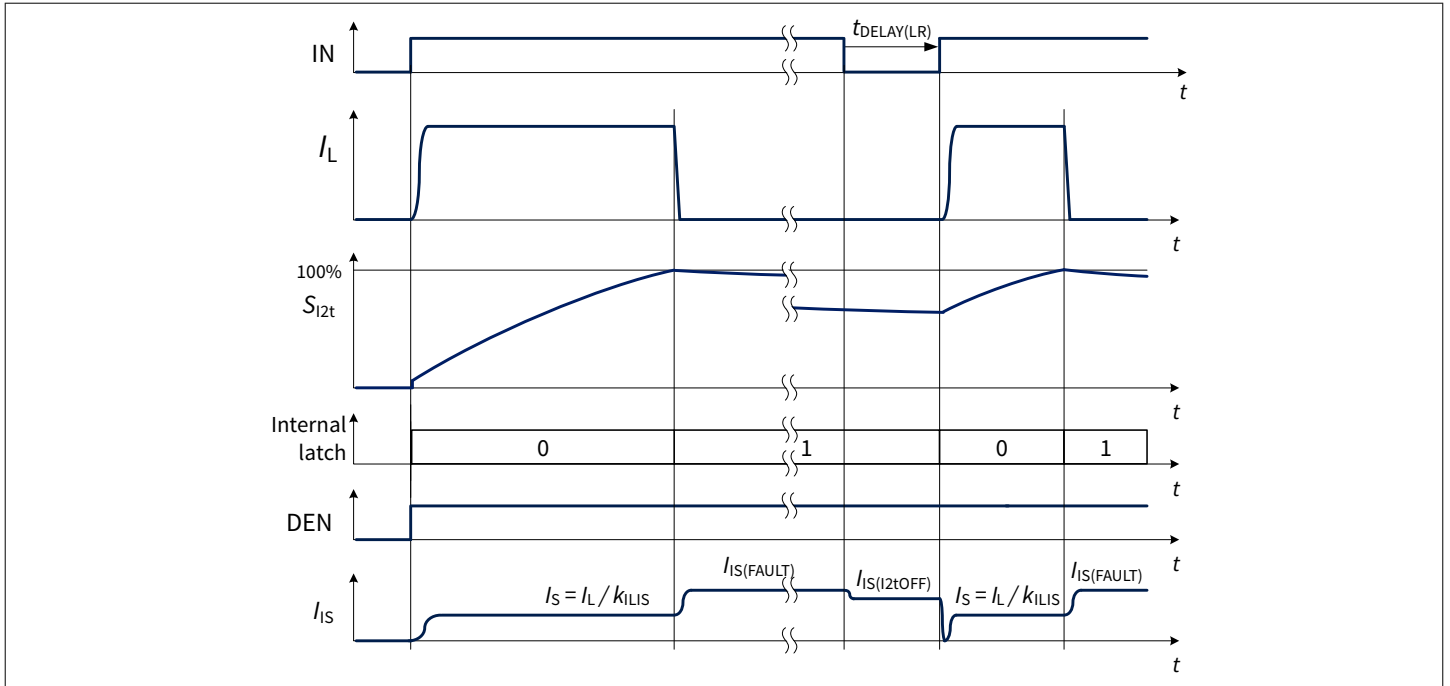

Figure 38 Intelligent latch timing diagram for IN reset in case of triggered I2t protection

With DEN pin: It is possible to “force” a reset of the internal latch without waiting for $t_{\text{DELAY(LR)}}$ by applying a pulse (rising edge followed by a falling edge) to the DEN pin while IN pin is “low”. The pulse applied to DEN pin must have a duration longer than $t_{\text{DEN(LR)}}$ to ensure a reset of the internal latch (see [Figure 39](#)).

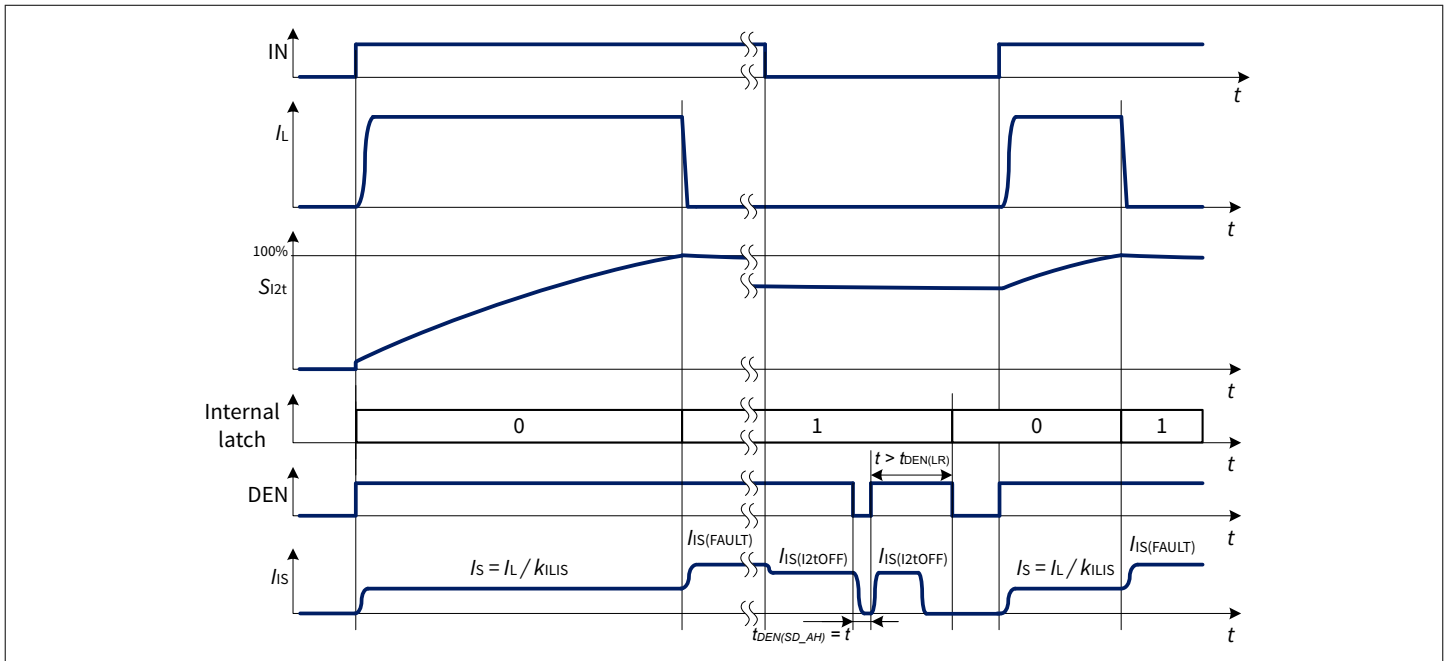

Figure 39 Intelligent latch timing diagram for DEN reset in case of triggered I2t protection

The intelligent latch strategy in case of device protection triggering is shown in [Figure 40](#).

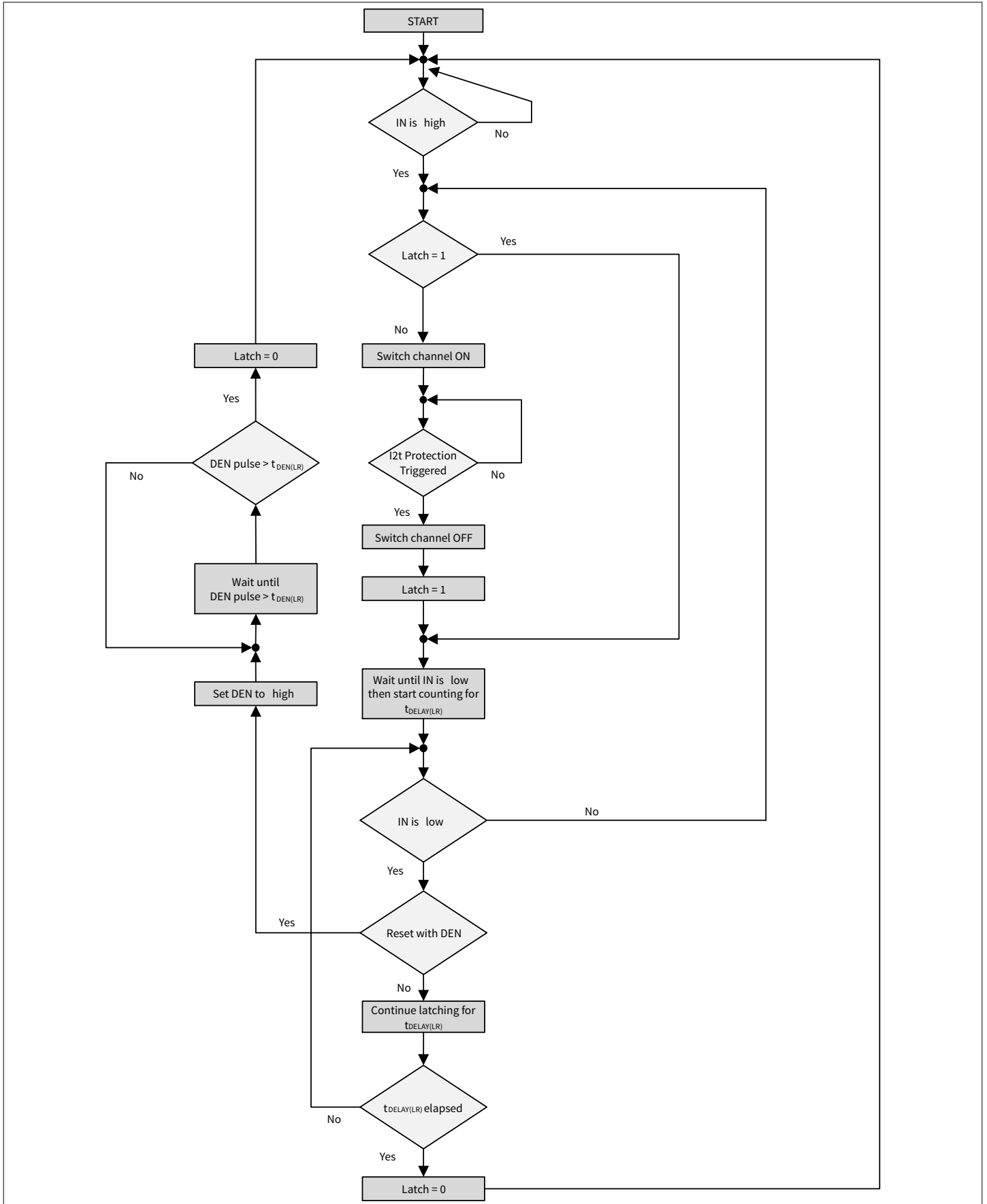

Figure 40 Intelligent latch flowchart in case of triggered I2t protection

9.2 Electrical characteristics protection

Table 14 Electrical characteristics I2t protection
 $V_S = 5\text{ V to }20\text{ V}$, $T_J = -40^\circ\text{C to }+150^\circ\text{C}$

 Unless otherwise specified typical values: $V_S = 13.5\text{ V}$, $T_J = 25^\circ\text{C}$

Parameter	Symbol	Values			Unit	Note or condition	P-Number
		Min.	Typ.	Max.			
I2t resistor threshold for short detection	R_{I2t_SHORT}	–	–	6	k Ω	1)	PRQ-890
Selection resistor for I2t protection curve 1	R_{I2t_1}	9.31	9.76	10.20	k Ω	–	PRQ-573
Selection resistor for I2t protection curve 2	R_{I2t_2}	14.06	14.70	15.30	k Ω	–	PRQ-574
Selection resistor for I2t protection curve 3	R_{I2t_3}	20.74	21.50	22.46	k Ω	–	PRQ-575
Selection resistor for I2t protection curve 4	R_{I2t_4}	30.91	32.40	33.66	k Ω	–	PRQ-576
Selection resistor for I2t protection curve 5	R_{I2t_5}	44.39	46.40	48.09	k Ω	–	PRQ-577
Selection resistor for I2t protection curve 6	R_{I2t_6}	65.38	68.10	70.82	k Ω	–	PRQ-578
I2t resistor threshold for open detection	R_{I2t_OPEN}	130	–	–	k Ω	1)	PRQ-889
Synchronization time of selection resistor for I2t protection curve setting	$t_{SYNC(RI2t)}$	12.8	19.2	25.6	μs	1)	PRQ-944
Time constant of all I2t protection curves	τ_{I2t}	7.0	10.0	13.0	s	1)	PRQ-1029
IDC of I2t protection curve 1	$I_{L(I2t_1)}$	6.8	7.5	8.3	A	1) 2)	PRQ-1030
IDC of I2t protection curve 2	$I_{L(I2t_2)}$	6.1	6.8	7.4	A	1) 2)	PRQ-1031
IDC of I2t protection curve 3	$I_{L(I2t_3)}$	5.5	6.1	6.7	A	1) 2)	PRQ-1032
IDC of I2t protection curve 4	$I_{L(I2t_4)}$	4.9	5.5	6.0	A	1) 2)	PRQ-1033
IDC of I2t protection curve 5	$I_{L(I2t_5)}$	4.4	4.9	5.4	A	1) 2)	PRQ-1034
IDC of I2t protection curve 6	$I_{L(I2t_6)}$	4.0	4.4	4.9	A	1) 2)	PRQ-1035

(table continues...)

Table 14 (continued) Electrical characteristics I2t protection

$V_S = 5\text{ V to }20\text{ V}$, $T_J = -40^\circ\text{C to }+150^\circ\text{C}$

Unless otherwise specified typical values: $V_S = 13.5\text{ V}$, $T_J = 25^\circ\text{C}$

Parameter	Symbol	Values			Unit	Note or condition	P-Number
		Min.	Typ.	Max.			
IDC of I2t Hysteresis Curve	$I_{L(I2t_HYST)}$	0.08	0.1	0.12	A	1) 2)	PRQ-1312
Initial current for I2t protection	$I_{L(I2t_I)}$	1.4	1.7	2.0	A	1) 2)	PRQ-1036

Transition times

Transition time I2t to idle	$t_{T(I2t_IDLE)}$	0.9	1.21	1.5	s	1) $I_L < 10\text{ mA}$	PRQ-1008
-----------------------------	--------------------	-----	------	-----	---	----------------------------	----------

1) Not subject to production test - specified by design.

2) I2t DC trigger level specified for times longer than 200s.

10 Diagnosis

For diagnosis purposes the device provides a sense current signal (I_{IS}) at IS pin. In case of disabled diagnostics (DEN pin set to "low"), IS pin becomes high impedance.

A sense resistor R_{SENSE} must be connected between IS pin and module ground if the diagnosis is used.

R_{SENSE} value has to be higher than 820 Ω (or 400 Ω when a central reverse battery protection is externally present on the battery feed) to limit the power losses in the sense circuitry.

A typical value is $R_{SENSE} = 1.2 \text{ k}\Omega$.

Due to the internal connection between IS pin and V_S supply voltage, it is not recommended to connect the IS pin to the sense current output of other devices if they are supplied by a different battery feed.

See [Figure 41](#) for details as an overview.

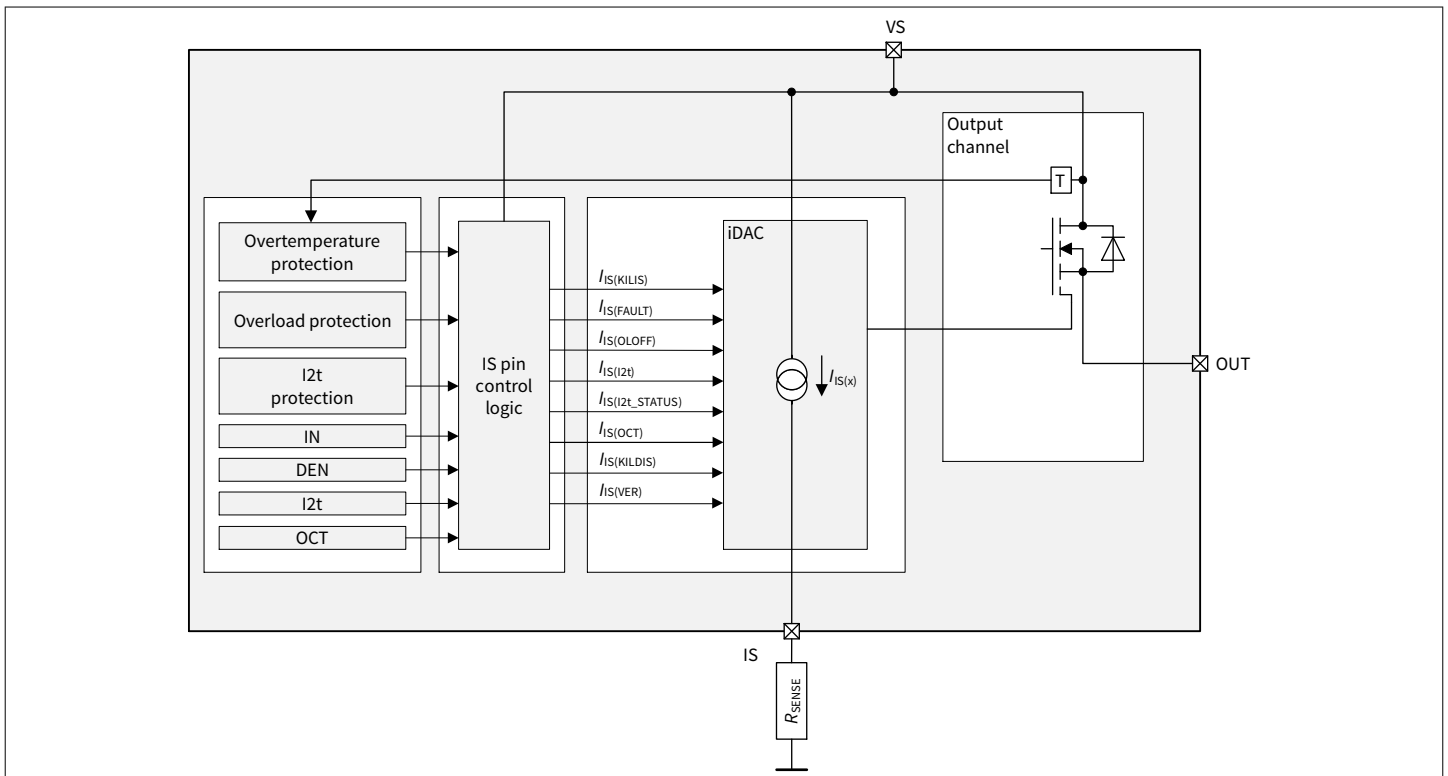

Figure 41 Diagnosis block diagram

[Table 15](#) gives a reference to the state of the IS pin during the operation of the device.

Table 15 SENSE signal, function of application condition

Application condition	Input level	DEN level	V_{OUT}	Diagnostic input
Normal operation and short circuit to GND	"low"	"high"	\sim GND	#1: Z
				$I_{IS(DEV OFF)}$, $I_{IS(I2t OFF)}$ if latch \neq 0
				#2: $I_{IS(I2t)}$
				#3: $I_{IS(STATUS_I2t)}$
				#4: $I_{IS(OCT)}$
Overtemperature	"low"	"high"	Z	#5: $I_{IS(VER)}$
				#1: $I_{IS(DEV OFF)}$

(table continues...)

Table 15 (continued) SENSE signal, function of application condition

Application condition	Input level	DEN level	V_{OUT}	Diagnostic input
				#2: $I_{IS(I2t)}$
				#3: $I_{IS(STATUS_I2t)}$
				#4: $I_{IS(OCT)}$
				#5: $I_{IS(VER)}$
Short circuit to V_S			V_S	#1: $I_{IS(OLOFF)}$
				$I_{IS(DEVOFF)}, I_{IS(I2tOFF)}$ if latch $\neq 0$
				#2: $I_{IS(I2t)}$
				#3: $I_{IS(STATUS_I2t)}$
				#4: $I_{IS(OCT)}$
				#5: $I_{IS(VER)}$
Open load			$< V_S - V_{DS(OLOFF)}^{1)}$	#1: Z
			$> V_S - V_{DS(OLOFF)}^{1)}$	#1: $I_{IS(OLOFF)}$
				(in both cases $I_{IS(DEVOFF)}$)
				$I_{IS(I2tOFF)}$ if latch $\neq 0$
				#2: $I_{IS(I2t)}$
				#3: $I_{IS(STATUS_I2t)}$
				#4: $I_{IS(OCT)}$
				#5: $I_{IS(VER)}$
Inverse current			$\sim V_{INV} = V_{OUT} > V_S$	#1: $I_{IS(OLOFF)}$
				$I_{IS(DEVOFF)}, I_{IS(I2tOFF)}$ if latch $\neq 0$
				#2: $I_{IS(I2t)}$
				#3: $I_{IS(STATUS_I2t)}$
				#4: $I_{IS(OCT)}$
				#5: $I_{IS(VER)}$
Normal operation	"high"		$\sim V_S$	#1: $I_{IS} = I_L / k_{ILIS}$
				#2: $I_{IS(I2t)}$
				#3: $I_{IS(STATUS_I2t)}$
				#4: $I_{IS(OCT)}$
				#5: $I_{IS} = I_L / k_{ILDIS}$
Overload			$< V_S$	#1: $I_{IS(FAULT)}$
Short circuit to GND			$\sim GND$	#1: $I_{IS(FAULT)}$
Overtemperature			Z	#1: $I_{IS(FAULT)}$
Short circuit to V_S			V_S	#1: $I_{IS} < I_L / k_{ILIS}$

(table continues...)

Table 15 (continued) **SENSE signal, function of application condition**

Application condition	Input level	DEN level	V_{OUT}	Diagnostic input
Open load			$\sim V_S^{2)}$	#2: $I_{IS(I2t)}$
				#3: $I_{IS(STATUS_I2t)}$
				#4: $I_{IS(OCT)}$
				#5: $I_{IS} = I_L / k_{ILDIS}$
				#1: $I_{IS} = I_{IS(EN)}$
Inverse current			$\sim V_{INV} = V_{OUT} > V_S$	#1: $I_{IS} = I_{IS(EN)}$
				#2: $I_{IS(I2t)}$
				#3: $I_{IS(STATUS_I2t)}$
				#4: $I_{IS(OCT)}$
				#5: $I_{IS} = I_{IS(EN)}$
CLS mode	"pwm"	"high"	$< V_S - V_{DS(OLOFF)}$	#1: Z
				#2: $I_{IS(I2t)}$
				#3: $I_{IS(STATUS_I2t)}$
				#4: $I_{IS(OCT)}$
				#5: Z
All conditions	n.a.	"low"	n.a.	Z

1) With additional pull-up resistor

2) The output current has to be smaller than $I_{L(OL)}$.

10.1 Sequential diagnosis

In ON and OFF state the device differentiates between the following diagnosis functions:

Address	IN	Function
#1	"high"	Current sense
#1	"low"	Open load in OFF
#2	"x"	I2t setting
#3	"x"	I2t status
#4	"x"	OCT setting
#5	"high"	Digital current sense
#5	"low"	Sense verification current

To sequentially change to the next diagnosis address (for example, "current sense" to "I2t setting") a pulse at the DEN pin (falling edge followed by a rising edge) has to be applied for a time of $t_{DEN(SD_AC)}$ ("DEN pulse duration for sequential diagnosis address change"). If the pulse is shorter than $t_{DEN(SD_AH)}$ ("DEN pulse duration for sequential diagnosis address hold") no address change is performed. The timing and modes are shown in Figure 42. After sweeping through the last diagnosis address the device starts again at the first diagnosis address.

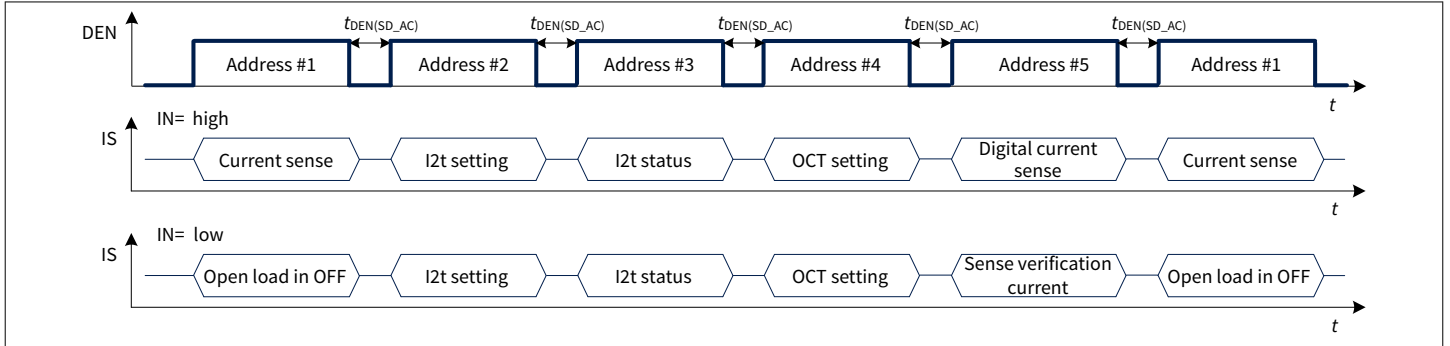

Figure 42 Sequential diagnosis function

If the pulse applied at the DEN pin is "low" for a duration longer than the DEN pulse duration for sequential diagnosis timeout $t_{DEN(SD_TO)}$, the actual diagnosis address is reset (see Figure 43). With the next DEN pin "high" signal the sequential diagnosis starts at the first diagnosis address (depending on the IN pin set to "high" or "low").

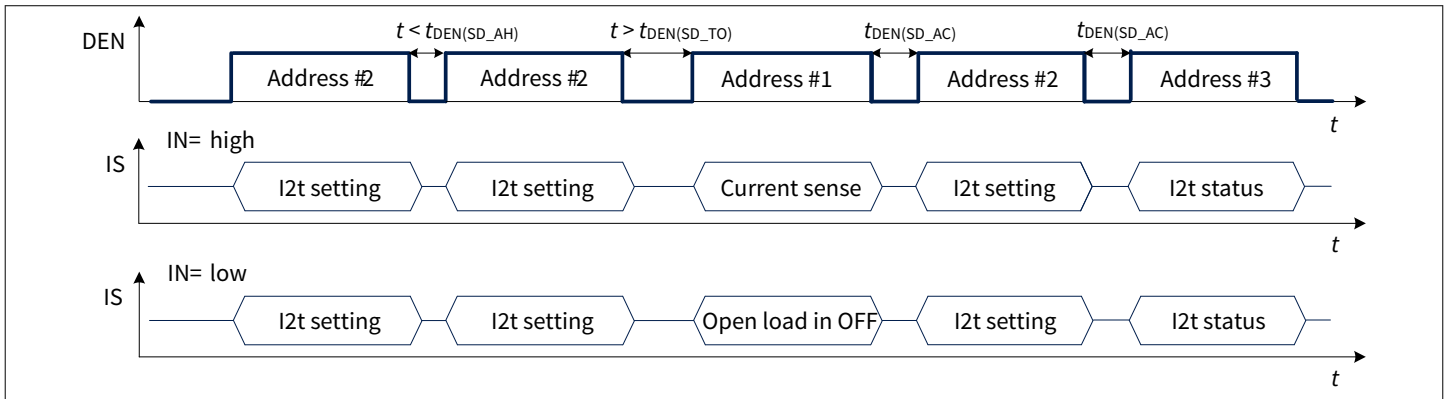

Figure 43 Sequential diagnosis timing

The PWM signal ($f_{VIN(CLS)}$ with $DC_{VIN(CLS)}$) which needs to be applied at the input pin in order to enter the CLS mode will be decoded from the diagnosis as IN equal to "high".

The states as well as the corresponding sense currents of the sequential diagnosis function are depicted in Figure 44.

Table 16 (continued) Transition descriptions

Name	Start state	End state	Transition condition	Duration time
i2tsta_olio	I2t status	Open load in OFF	(DEN = "low" for $t_{DEN(SD_TO)}$) AND IN = "low"	$t_{SIS(ON234)}$
octset_olio	OCT setting	Open load in OFF	(DEN = "low" for $t_{DEN(SD_TO)}$) AND IN = "low"	$t_{SIS(ON234)}$
isver_olio	Sense verification current	Open load in OFF	(DEN = "low" for ($t_{DEN(SD_AC)}$ OR $t_{DEN(SD_TO)}$)) AND IN = "low"	$t_{SIS(ON234)}$
cs_i2tset	Current sense	I2t setting	DEN = "low" for $t_{DEN(SD_AC)}$	$t_{SIS(ON234)}$
olio_i2tset	Open load in OFF	I2t setting	DEN = "low" for $t_{DEN(SD_AC)}$	$t_{SIS(ON234)}$
i2tset_i2tsta	I2t setting	I2t status	DEN = "low" for $t_{DEN(SD_AC)}$	$t_{SIS(ON234)}$
i2tsta_octset	I2t status	OCT setting	DEN = "low" for $t_{DEN(SD_AC)}$	$t_{SIS(ON234)}$
octset_dcs	OCT setting	Digital current sense	(DEN = "low" for $t_{DEN(SD_AC)}$) AND IN = "high" ¹⁾	$t_{SIS(ON15)}$
isver_dcs	Sense verification current	Digital current sense	IN = "high" ¹⁾	$t_{SIS(DIAG)}$
octset_isver	OCT setting	Sense verification current	(DEN = "low" for $t_{DEN(SD_AC)}$) AND IN = "low" ¹⁾	$t_{SIS(ON234)}$
dcs_isver	Digital current sense	Sense verification current	IN = "low"	$t_{SIS(ON234)}$

1) CLS mode with IN = "pwm" are decoded as IN = "high"

10.1.1 Current sense (address #1 - IN=high)

A current proportional to the load current according to

$$k_{ILIS} = \frac{I_L}{I_{IS}} \quad (9)$$

is provided at IS pin when the following conditions are fulfilled:

- Address #1 and IN = "high"
- The diagnosis (current sense) is enabled with $V_{DS} < V_{DS(OLOFF)}$
- No fault (as described in [Chapter 8.3](#)) is present or was latched (see [Figure 46](#) for further details)

A fault current $I_{IS(FAULT)}$ is provided at the IS pin when a fault is present or was latched.

The accuracy of the sense current I_{IS} depends on the load current I_L . The sense current I_{IS} increases linearly with I_L output current until it reaches the saturation current $I_{IS(SAT)}$. In case of open load at the output stage (I_L close to 0 A), the maximum sense current $I_{IS(EN)}$ (no load, diagnosis enabled) is specified. This condition is shown in [Figure 45](#). The blue line represents the ideal k_{ILIS} line, while the red lines show the behavior of a typical product.

An external RC filter between IS pin and microcontroller ADC input pin is recommended to reduce the signal ripple and oscillations (a minimum time constant of 1 μ s for the RC filter is recommended).

The k_{ILIS} factor is specified with limits that take into account effects due to temperature, supply voltage and manufacturing process. Tighter limits are possible (within a defined current window) with calibration:

- A well-defined and precise current ($I_{L(CAL)}$) is applied at the output during end-of-line test at customer side
- The corresponding current at IS pin is measured and the k_{ILIS} is calculated ($k_{ILIS} @ I_{L(CAL)}$)
- Within the current range going to $I_{L(CAL)_L}$ to $I_{L(CAL)_H}$ the k_{ILIS} is equal to $k_{ILIS} @ I_{L(CAL)}$ with limits defined by Δk_{ILIS}

The derating of k_{ILIS} after calibration is specified by Δk_{ILIS} , calculated using the following formulas:

$$\Delta k_{ILIS,MAX} = 100 \cdot \text{MAX} \left(\frac{k_{ILIS} @ I_{L(CAL)_L}}{k_{ILIS} @ I_{L(CAL)}} - 1, \frac{k_{ILIS} @ I_{L(CAL)_H}}{k_{ILIS} @ I_{L(CAL)}} - 1 \right) \quad (10)$$

$$\Delta k_{ILIS,MIN} = 100 \cdot \text{MIN} \left(\frac{k_{ILIS} @ I_{L(CAL)_L}}{k_{ILIS} @ I_{L(CAL)}} - 1, \frac{k_{ILIS} @ I_{L(CAL)_H}}{k_{ILIS} @ I_{L(CAL)}} - 1 \right)$$

The calibration is intended to be performed at $T_{A(CAL)} = 25^\circ\text{C}$. The parameter Δk_{ILIS} includes the drift over temperature as well as the drift over the current range from $I_{L(CAL)_L}$ to $I_{L(CAL)_H}$.

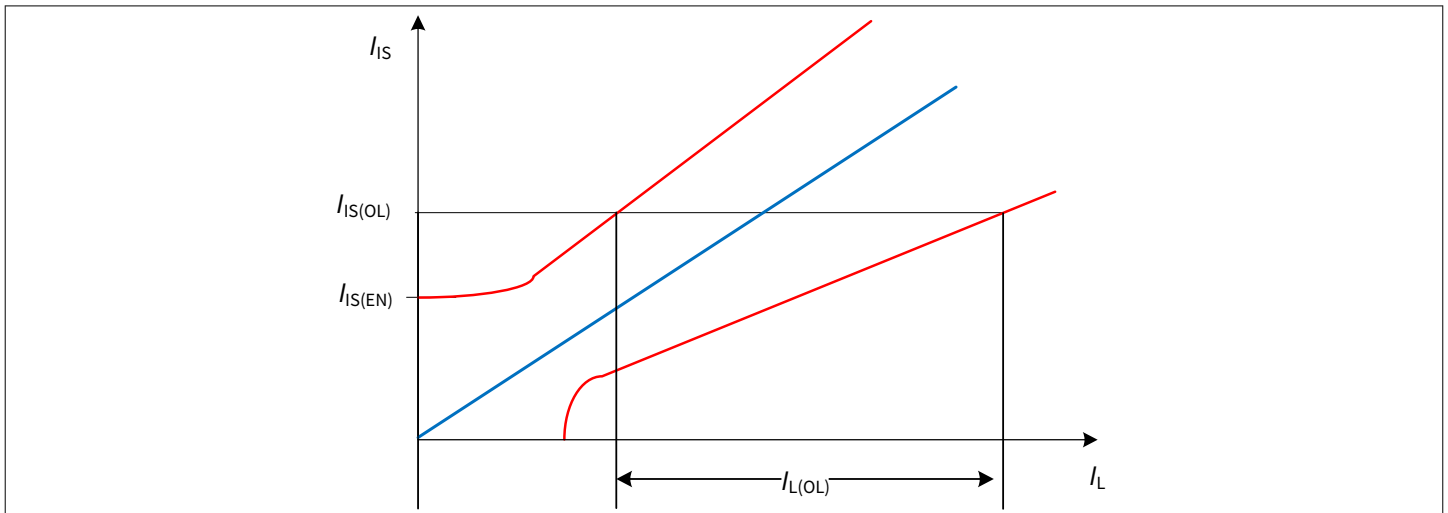

Figure 45 Current sense ratio in open load at ON condition

As soon as a protection event occurs the device is switched OFF and a fault current $I_{IS(FAULT)}$ is provided by the IS pin if DEN is set to high (see [Chapter 8.3](#) for more details). In fault condition the current $I_{IS(FAULT)}$ is provided each time the device diagnosis is activated by DEN = "high".

[Figure 46](#) shows the relation between $I_{IS} = I_L / k_{ILIS}$, $I_{IS(SAT)}$ and $I_{IS(FAULT)}$.

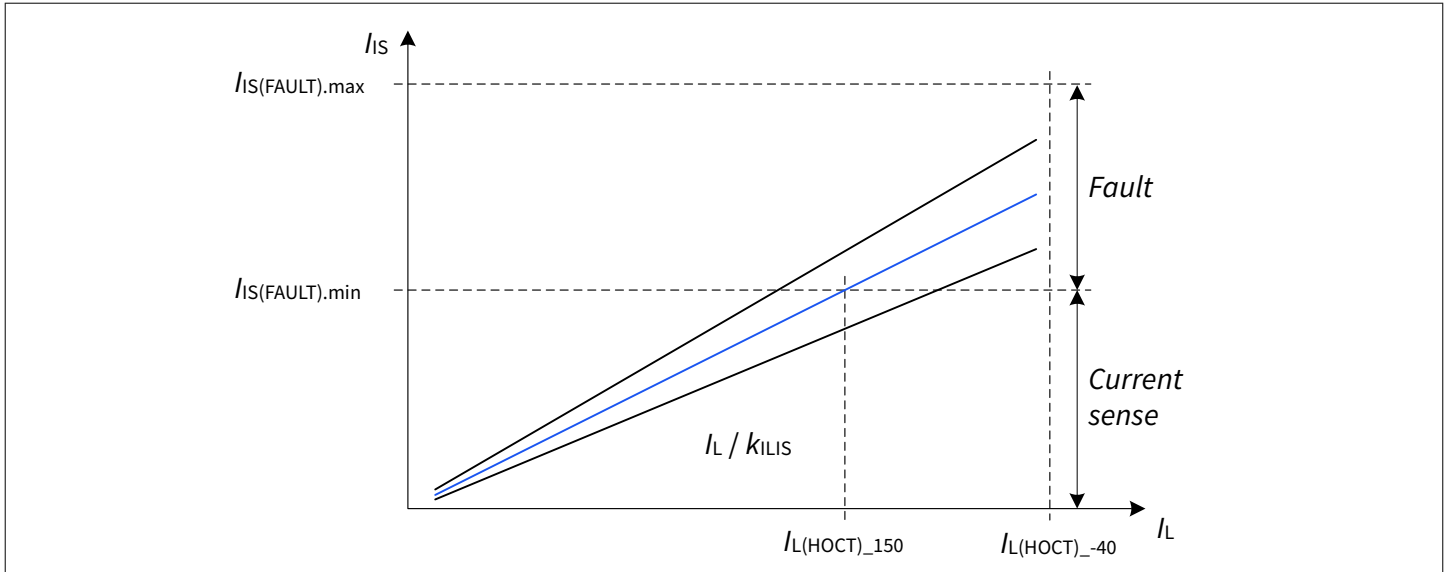

Figure 46 Current sense behavior - overview

10.1.2 Open load in OFF (address #1 - IN = low)

When the input signal is "low" and the address #1 is selected, the device will measure the drain-source voltage and compare it with the open load V_{DS} detection threshold in OFF state $V_{DS(OLOFF)}$. By the use of external components (see Figure 54), it is possible to detect if the load is missing or if there is a short circuit to battery.

If a fault condition was detected by the device either the device protection fault current $I_{IS(DEVOFF)}$ or the I2t protection fault current $I_{IS(I2tOFF)}$ is provided by the IS pin each time the channel diagnosis is checked in OFF state. See Figure 47 for further details.

In OFF state, when DEN pin is set to "high" the V_{DS} voltage is compared with a threshold voltage $V_{DS(OLOFF)}$. If the load is properly connected and there is no short circuit to battery, $V_{DS} \sim V_S$ therefore $V_{DS} > V_{DS(OLOFF)}$. When the diagnosis is active and $V_{DS} \leq V_{DS(OLOFF)}$, a current $I_{IS(OLOFF)}$ is provided by IS pin. Figure 47 shows the relationship between $I_{IS(OLOFF)}$, $I_{IS(DEVOFF)}$ and $I_{IS(I2tOFF)}$ as functions of V_{DS} . By the fact that the three currents do not overlap, it is always possible to differentiate between open load in OFF, I2t protection and device protection triggered. Furthermore, the first and highest prioritization has the I2t protection fault current $I_{IS(I2tOFF)}$, second has the device protection fault current $I_{IS(DEVOFF)}$ and third has the open load in OFF current $I_{IS(OLOFF)}$.

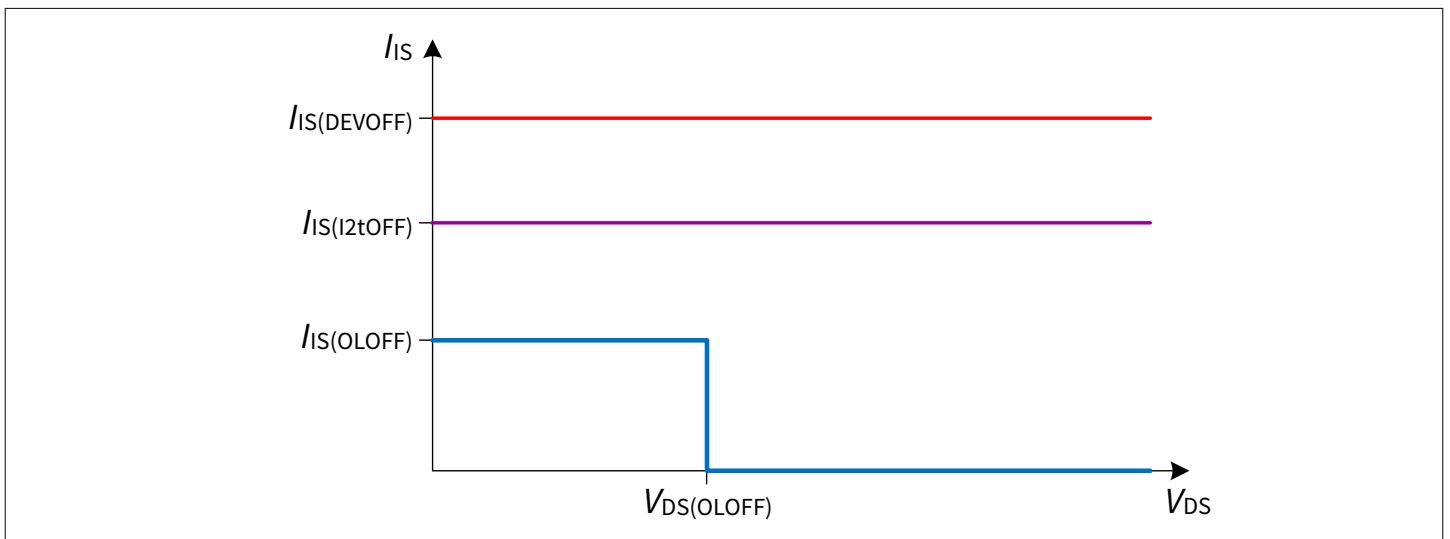

Figure 47 I_{IS} in OFF state

It is necessary to wait a time $t_{IS(OLOFF)_D}$ between the falling edge of the input pin and the sensing at IS pin for open load in OFF diagnosis to allow the internal comparator to settle. In Figure 48 the timings for an open load detection are shown - the load is always disconnected.

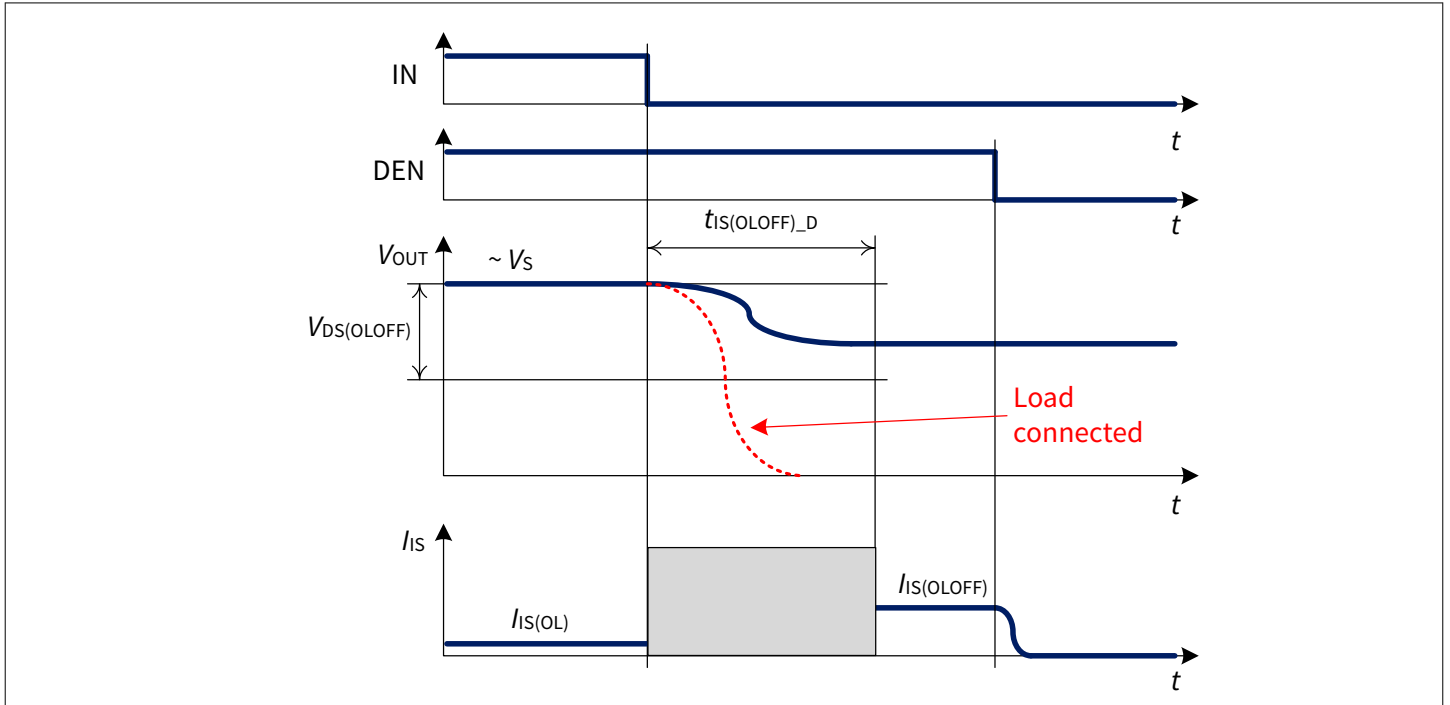

Figure 48 Open load in OFF timings - load disconnected

10.1.3 I2t setting (address #2 - IN = x)

The device provides for each I2t protection curve setting a corresponding sense current $I_{IS(I2t_x)}$ at the IS pin in case of setting the sequential diagnosis mode to address #2. The I2t settings are set by the resistor at the I2t pin (see Figure 49).

The device offers an open and short detection of the I2t pin at the IS pin. In this case a pin short current $I_{IS(I2t_SHORT)}$ or a pin open current $I_{IS(I2t_OPEN)}$ will be distributed during the diagnosis of the I2t setting.

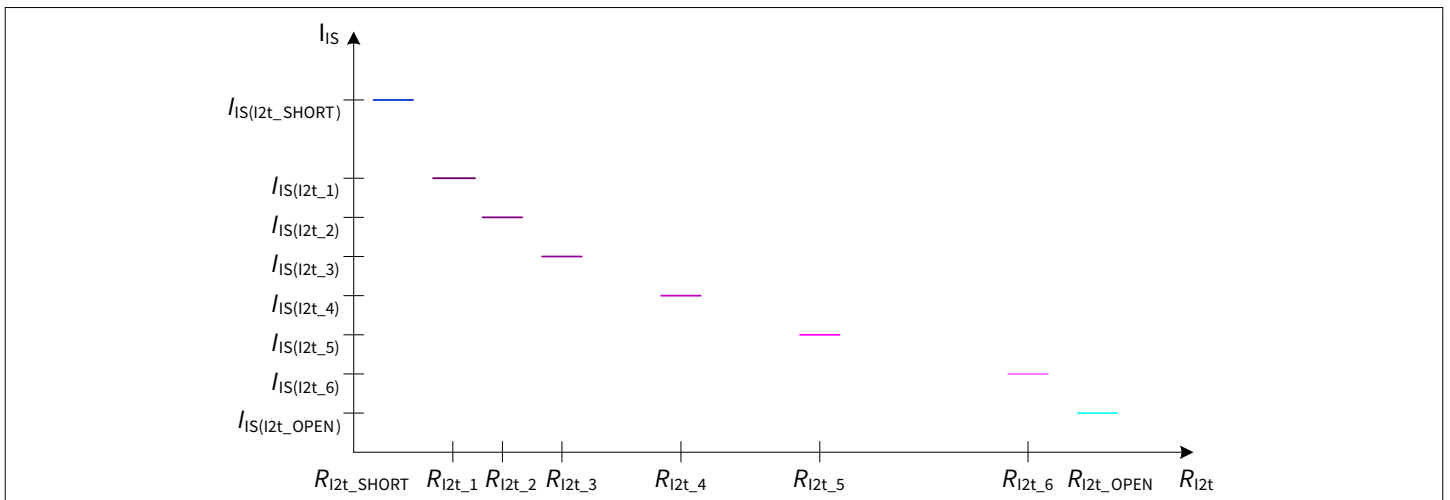

Figure 49 Diagnosis of I2t setting

10.1.4 I2t status (address #3 - IN = x)

A current proportional to the actual I2t status S_{I2t_A} according to

$$I_{IS(\text{STATUS_I2t_x})} = S_{I2t_A} \cdot I_{IS(I2t_x_100\%)} \quad (11)$$

is provided at the IS pin depending on the selected I2t protection curve (see Figure 50). When the I2t protection curve status has reached 100% the $I_{IS(\text{STATUS_I2t_x})}$ is equal to $I_{IS(I2t_x_100\%)}$.

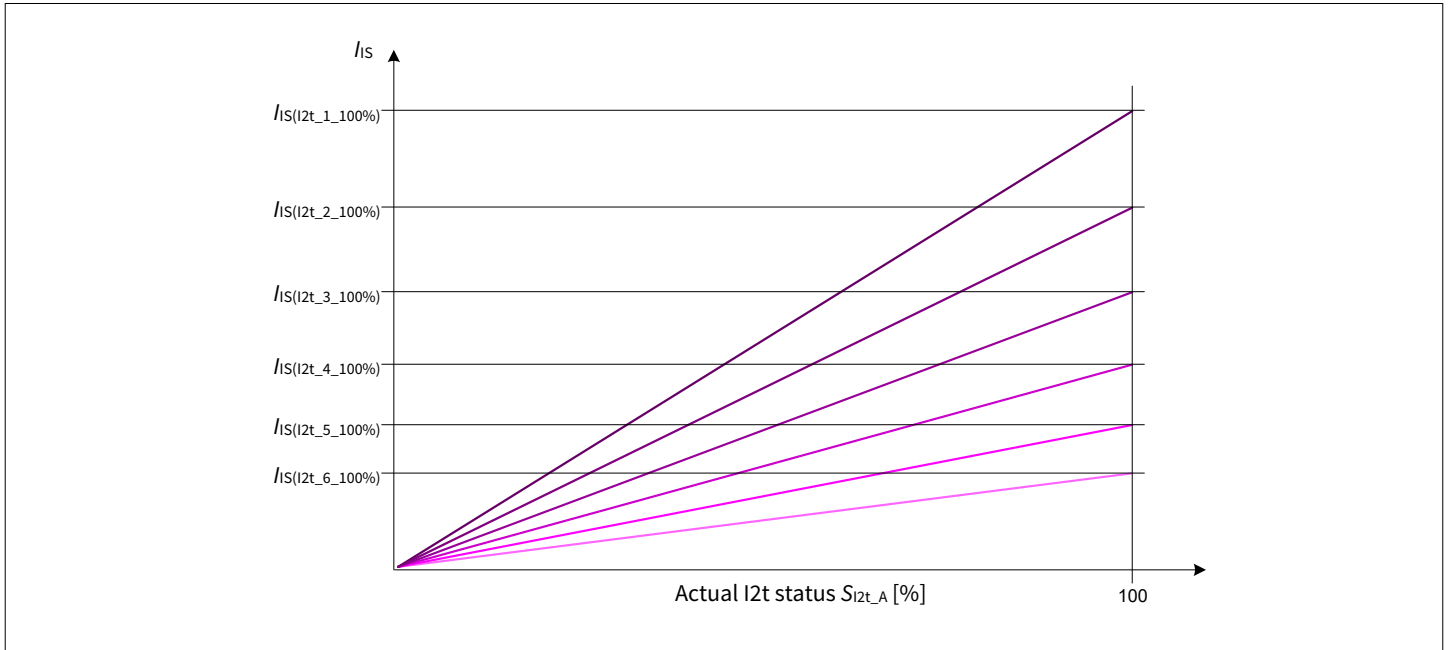

Figure 50 Diagnosis of I2t status calculation

10.1.5 OCT setting (address #4 - IN = x)

A current according to

$$I_{IS(\text{OCT})} [A] = 54.5 \cdot I_{\text{OCT}} [A] \quad (12)$$

is provided at the IS pin depending on the selected OCT setting during readout of sequential diagnosis address #4 (see Figure 51). The I_{OCT} range is limited by $I_{\text{OCT,MAX}}$ and $I_{\text{OCT,MIN}}$ for highest and lowest configurable overcurrent threshold respectively.

The device offers an open and short detection of the OCT pin at the IS pin. In this case a pin short current $I_{IS(\text{OCT_SHORT})}$ or a pin open current $I_{IS(\text{OCT_OPEN})}$ will be distributed during the diagnosis of the OCT setting.

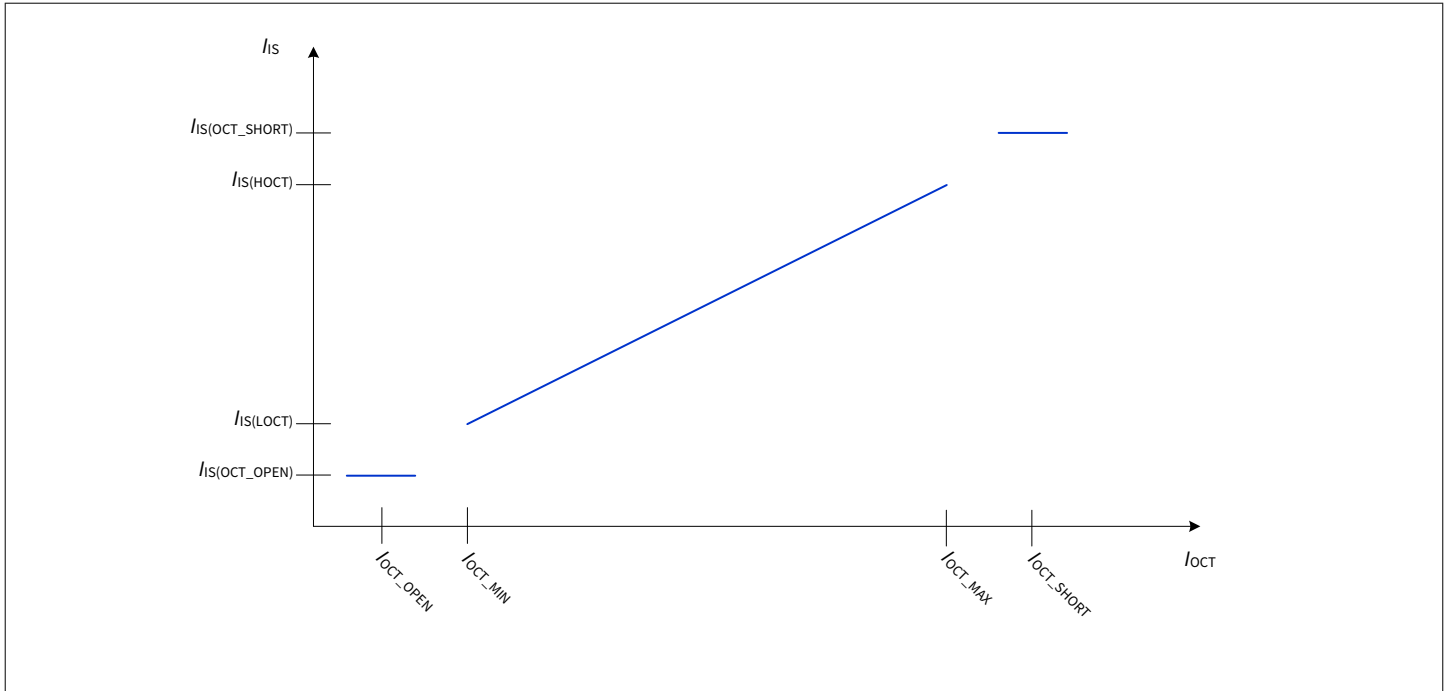

Figure 51 **Diagnosis of overcurrent threshold setting**

10.1.6 **Digital current sense (address #5 - IN = high)**

A current proportional to the load current according to

$$k_{ILDIS} = \frac{I_L}{I_{DIS}} \tag{13}$$

is provided at IS pin when the following conditions are fulfilled:

- Address #5 and IN = "high"
- The diagnosis (current sense) is enabled with $V_{DS} < V_{DS(OLOFF)}$
- No fault (as described in [Chapter 8.3](#)) is present or was latched (see [Figure 46](#) for further details)

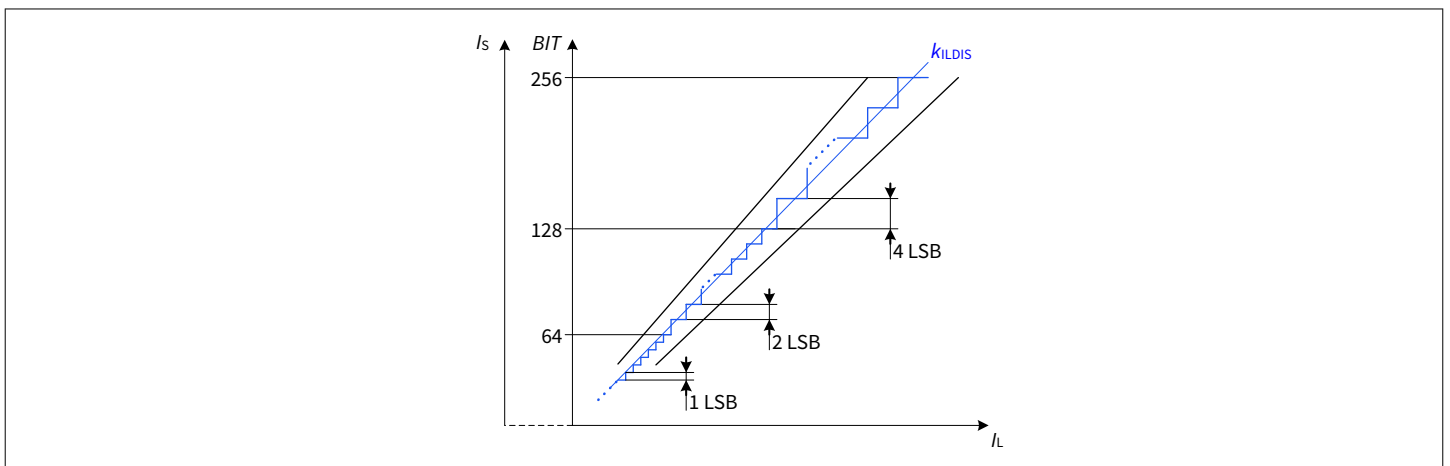

Figure 52 **Digital current sense behavior - overview**

The digital current sense settling time for an infinite fast current ramp is determined by:

$$t_{DIS_SET} = \begin{cases} I_L \leq 64 \cdot LSB, & \frac{I_L}{LSB} \cdot t_{CON} \\ 65 \cdot LSB < I_L \leq 128 \cdot LSB, & \left(64 + \frac{I_L - 64 \cdot LSB}{2LSB}\right) \cdot t_{CON} \\ 129 \cdot LSB < I_L \leq 256 \cdot LSB, & \left(96 + \frac{I_L - 128 \cdot LSB}{4LSB}\right) \cdot t_{CON} \end{cases} \quad (14)$$

10.1.7 Sense verification current (address #5 - IN = low)

To verify the function of the current sensing path in OFF state, the device offers a sense verification address. In this mode a predefined current $I_{S(VER)}$ is provided at the current sense pin independent of the load condition.

10.2 SENSE timings

Figure 53 shows the timing during settling $t_{SIS(ON)}$ and disabling $t_{SIS(OFF)}$ of the SENSE (including the case of load change). As a proper signal cannot be established before the load current is stable (therefore before t_{ON}), the SENSE settling time after start-up is defined by $t_{SIS(DIAG)}$.

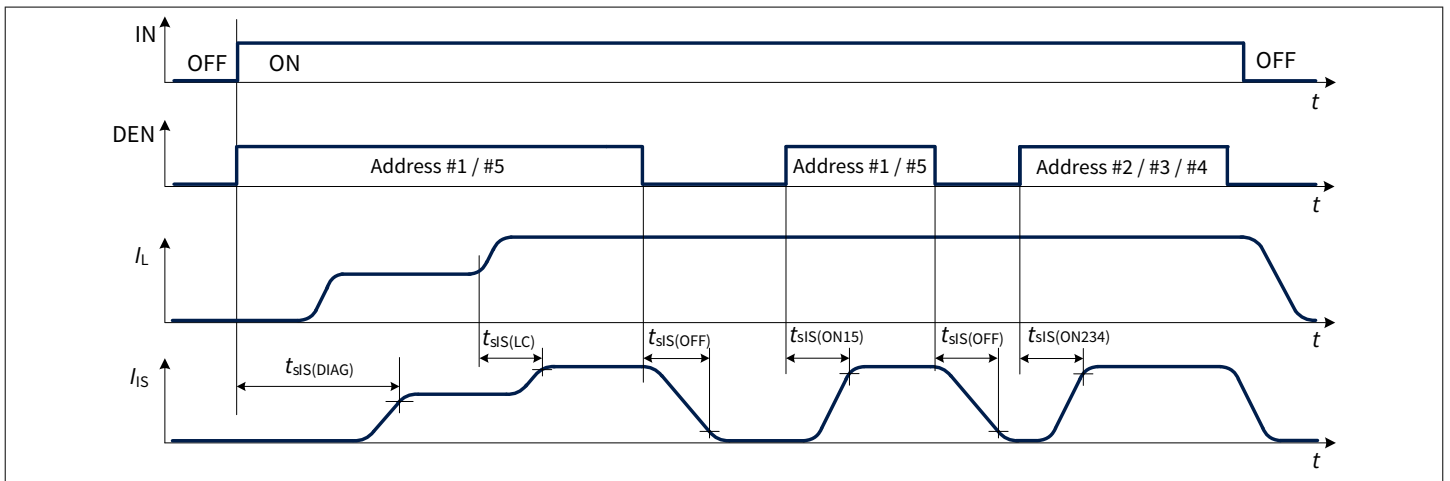

Figure 53 SENSE settling/disabling timing

10.3 Electrical characteristics diagnosis

Table 17 Electrical characteristics diagnosis
 $V_S = 5\text{ V to }20\text{ V}, T_J = -40^\circ\text{C to }+150^\circ\text{C}$

 Unless otherwise specified typical values: $V_S = 13.5\text{ V}, T_J = 25^\circ\text{C}$

 Typical resistive loads connected to the outputs for testing (unless otherwise specified): $R_L = 2.1\ \Omega$

Parameter	Symbol	Values			Unit	Note or condition	P-Number
		Min.	Typ.	Max.			
SENSE fault current	$I_{IS(FAULT)}$	4.4	5.5	10	mA	IN = "high" Device or I2t protection triggered Address #1 $V_S = 6\text{ V}$	PRQ-287
Device protection fault current	$I_{IS(DEVOFF)}$	4.4	6.1	10	mA	IN = "low" Device protection triggered Address #1 $V_S = 6\text{ V}$	PRQ-893
I2t protection fault current	$I_{IS(I2tOFF)}$	2.56	3.20	3.84	mA	¹⁾ IN = "low" I2t protection triggered Address #1	PRQ-631
SENSE open load in OFF current	$I_{IS(OLOFF)}$	0.8	1.15	1.5	mA	IN = "low" Address #1	PRQ-288
Sense verification current	$I_{IS(VER)}$	400	500	600	μA	IN = "low" Address #5	PRQ-1333
SENSE open load in OFF delay time (from ON to OFF)	$t_{IS(OLOFF)_D}$	–	5	20	μs	$V_{DS} < V_{OL(OFF)}$ from IN falling edge to $V_{IS} = R_{SENSE} \cdot 0.9$ $\cdot I_{IS(OLOFF),MIN}$ DEN = "high" Address #1	PRQ-290
Open load VDS detection threshold in OFF state	$V_{DS(OLOFF)}$	1.3	1.8	2.3	V	IN="low" Address #1	PRQ-292
SENSE settling time with nominal load current stable	$t_{sIS(ON15)}$	–	5	40	μs	$I_L = I_{L(NOM)_85}$ DEN from "low" to "high" IN = "high" Address #1, #5	PRQ-293

(table continues...)

Table 17 (continued) Electrical characteristics diagnosis

$V_S = 5\text{ V to }20\text{ V}$, $T_J = -40^\circ\text{C to }+150^\circ\text{C}$

Unless otherwise specified typical values: $V_S = 13.5\text{ V}$, $T_J = 25^\circ\text{C}$

Typical resistive loads connected to the outputs for testing (unless otherwise specified): $R_L = 2.1\ \Omega$

Parameter	Symbol	Values			Unit	Note or condition	P-Number
		Min.	Typ.	Max.			
SENSE settling time with nominal load current stable after startup	$t_{\text{SIS(DIAG)}}$	–	400	750	μs	¹⁾ $I_L = I_{L(\text{NOM})_{85}}$ IN, DEN from “low” to “high” Address #1, #5	PRQ-276
SENSE settling time for sequential diagnosis	$t_{\text{SIS(ON234)}}$	–	5	20	μs	¹⁾ DEN from “low” to “high” IN = “high” Address #2, #3, #4 IN = “low” Address #1, #2, #3, #4, #5	PRQ-1201
SENSE disable time	$t_{\text{SIS(OFF)}}$	–	5	20	μs	¹⁾ From DEN falling edge to $I_{\text{IS}} = I_{\text{IS(OFF)}}$ See Figure 53 IN=“high” Address #1	PRQ-295
SENSE settling time after load change	$t_{\text{SIS(LC)}}$	–	5	20	μs	¹⁾ From 10% $I_{L(\text{NOM})_{85}}$ to $I_{L(\text{NOM})_{85}}$ See Figure 53 IN=“high” Address #1	PRQ-296
Load jump duration in Address 5	$t_{\text{SIS(LC_Address5)}}$	28	37	46	μs	¹⁾ From 10% $I_{L(\text{NOM})_{85}}$ to $I_{L(\text{NOM})_{85} \cdot x}$ for $x=1,2,3,4$. See Figure 53 IN=“high” Address #5	PRQ-1489
Digital SENSE conversion time	t_{CON}	720	800	880	ns	¹⁾	PRQ-1455

(table continues...)

Table 17 (continued) Electrical characteristics diagnosis
 $V_S = 5\text{ V to }20\text{ V}$, $T_J = -40^\circ\text{C to }+150^\circ\text{C}$

 Unless otherwise specified typical values: $V_S = 13.5\text{ V}$, $T_J = 25^\circ\text{C}$

 Typical resistive loads connected to the outputs for testing (unless otherwise specified): $R_L = 2.1\ \Omega$

Parameter	Symbol	Values			Unit	Note or condition	P-Number
		Min.	Typ.	Max.			
DEN pulse duration for sequential diagnosis address change	$t_{\text{DEN(SD_AC)}}$	25	50	75	μs	1)	PRQ-610
DEN pulse duration for sequential diagnosis timeout	$t_{\text{DEN(SD_TO)}}$	150	–	–	μs	1)	PRQ-937
DEN pulse duration for sequential diagnosis address hold	$t_{\text{DEN(SD_AH)}}$	0	5	10	μs	1)	PRQ-1468

1) Not subject to production test - specified by design.

Table 18 Electrical characteristics diagnosis
 $V_S = 5\text{ V to }20\text{ V}$, $T_J = -40^\circ\text{C to }+150^\circ\text{C}$

 Unless otherwise specified typical values: $V_S = 13.5\text{ V}$, $T_J = 25^\circ\text{C}$

 Typical resistive loads connected to the outputs for testing (unless otherwise specified): $R_L = 2.1\ \Omega$

Parameter	Symbol	Values			Unit	Note or condition	P-Number
		Min.	Typ.	Max.			
SENSE saturation current	$I_{\text{IS(SAT)}}$	4.4	–	15	mA	1) $V_{\text{SIS}} = V_S - V_{\text{IS}} \geq 2\text{ V}$ See Figure 46	PRQ-277
SENSE leakage current when disabled	$I_{\text{IS(OFF)}}$	–	0.01	0.5	μA	DEN = "low" $V_{\text{IS}} = 0\text{ V}$	PRQ-279
SENSE leakage current when enabled at $T_J \leq 85^\circ\text{C}$	$I_{\text{IS(EN)_85}}$	–	0.2	1	μA	1) $T_J \leq 85^\circ\text{C}$ DEN = "high" $I_L = 0\text{ A}$ See Figure 45	PRQ-280
SENSE leakage current when enabled at $T_J = 150^\circ\text{C}$	$I_{\text{IS(EN)_150}}$	–	0.2	1	μA	$T_J = 150^\circ\text{C}$ DEN = "high" $I_L = 0\text{ A}$ See Figure 45	PRQ-281

(table continues...)

Table 18 (continued) Electrical characteristics diagnosis
 $V_S = 5\text{ V to }20\text{ V}, T_J = -40^\circ\text{C to }+150^\circ\text{C}$

 Unless otherwise specified typical values: $V_S = 13.5\text{ V}, T_J = 25^\circ\text{C}$

 Typical resistive loads connected to the outputs for testing (unless otherwise specified): $R_L = 2.1\ \Omega$

Parameter	Symbol	Values			Unit	Note or condition	P-Number
		Min.	Typ.	Max.			
Saturation voltage in kLIS operation - (VS - VIS)	V_{SIS_k}	–	0.5	1	V	1) $V_S = 5\text{ V}$ IN = DEN = "high" $I_L \leq 1.2 * I_{L(NOM)_85}$	PRQ-282
Saturation voltage in open load at OFF diagnosis - (VS - VIS)	V_{SIS_OL}	–	0.5	1	V	1) $V_S = 5\text{ V}$ $I_{IS} = I_{IS(OLOFF)_Min}$ IN = "low" DEN = "high"	PRQ-283
Saturation voltage in fault diagnosis - (VS - VIS)	V_{SIS_F}	–	0.5	1	V	1) $V_S = 5\text{ V}$ $I_{IS} = I_{IS(FAULT)_Min}$ IN = "low" DEN = "high" latch $\neq 0$ $-40^\circ\text{C} < T_J \leq 150^\circ\text{C}$	PRQ-284
Saturation voltage in sequential diagnosis - (VS - VIS)	V_{SIS_SD}	–	0.5	1	V	1) $V_S = 5\text{ V}$ IN = DEN = "high" Address #2: $R_{12t} = 10\text{ k}\Omega$ Address #3: $I_{IS(I2t_1_100\%)}$ Address #4: $I_{OCT} = 50\ \mu\text{A}$ Address #5: $I_L \leq 1.2 * I_{L(NOM)_85}$	PRQ-1453
Power supply to IS pin clamping voltage at $T_J = -40^\circ\text{C}$	$V_{SIS(CLAMP)_-40}$	33	36.5	42	V	$I_{IS} = 1\text{ mA}$ $T_J = -40^\circ\text{C}$ See Figure 20	PRQ-285
Power supply to IS pin clamping voltage at $T_J \geq 25^\circ\text{C}$	$V_{SIS(CLAMP)_25}$	35	38	44	V	2) $I_{IS} = 1\text{ mA}$ $T_J \geq 25^\circ\text{C}$ See Figure 20	PRQ-286

1) Not subject to production test - specified by design.

 2) Tested at $T_J = 150^\circ\text{C}$.

10.3.1 Electrical characteristics diagnosis - power output stages

Table 19 Diagnosis power output stage

$V_S = 5\text{ V to }20\text{ V}$, $T_J = -40^\circ\text{C to }150^\circ\text{C}$

Unless otherwise specified typical values: $V_S = 13.5\text{ V}$, $T_J = 25^\circ\text{C}$

Typical resistive loads connected to the outputs for testing (unless otherwise specified): $R_L = 2.1\ \Omega$

Parameter	Symbol	Values			Unit	Note or condition	P-Number
		Min.	Typ.	Max.			
Open load output current							
Open load output current at IIS = 4 μA	$I_{L(OL)_4\mu}$	5	33	61	mA	IN = "high" Address #1 $I_{IS} = I_{IS(OL)} = 4\ \mu\text{A}$	PRQ-1050
Current sense ratio							
Current sense ratio at -IL = IL01	k_{ILIS01}	-85%	8300	+85%	-	$I_{L01} = 30\text{ mA}$ IN = "high" Address #1	PRQ-1051
Current sense ratio at -IL = IL05	k_{ILIS05}	-30%	6900	+30%	-	$I_{L05} = 150\text{ mA}$ IN = "high" Address #1	PRQ-1052
Current sense ratio at -IL = IL07	k_{ILIS07}	-20%	6900	+20%	-	$I_{L07} = 300\text{ mA}$ IN = "high" Address #1	PRQ-1053
Current sense ratio at -IL = IL11	k_{ILIS11}	-15%	6900	+15%	-	$I_{L11} = 1.5\text{ A}$ IN = "high" Address #1	PRQ-1054
Current sense ratio at -IL = IL12	k_{ILIS12}	-8%	6900	+8%	-	$I_{L12} = 3\text{ A}$ IN = "high" Address #1	PRQ-1055
Current sense ratio at -IL = IL13	k_{ILIS13}	-8%	6900	+8%	-	$I_{L13} = 5\text{ A}$ IN = "high" Address #1	PRQ-1056
Current sense ratio at -IL = IL14	k_{ILIS14}	-8%	6900	+8%	-	$I_{L14} = 7.5\text{ A}$ IN = "high" Address #1	PRQ-1057

(table continues...)

Table 19 (continued) Diagnosis power output stage
 $V_S = 5\text{ V to }20\text{ V}$, $T_J = -40^\circ\text{C to }150^\circ\text{C}$

 Unless otherwise specified typical values: $V_S = 13.5\text{ V}$, $T_J = 25^\circ\text{C}$

 Typical resistive loads connected to the outputs for testing (unless otherwise specified): $R_L = 2.1\ \Omega$

Parameter	Symbol	Values			Unit	Note or condition	P-Number
		Min.	Typ.	Max.			
SENSE current derating							
SENSE current derating with nominal current calibration	$\Delta k_{ILIS(NOM)}$	-4	0	4	%	1) $I_{L(CAL)} = I_{L13}$ $I_{L(CAL)_H} = I_{L14}$ $I_{L(CAL)_L} = I_{L12}$ $T_{A(CAL)} = 25^\circ\text{C}$	PRQ-1193
I2t setting							
Diagnosis of I2t pin short	$I_{IS(I2t_SHORT)}$	3.40	3.68	3.97	mA	Address #2 $V_S = 6\text{ V}$ $R_{I2t} = R_{I2t_SHORT}$ See Figure 49	PRQ-613
Diagnosis of I2t_1 setting	$I_{IS(I2t_1)}$	2.57	2.83	3.09	mA	Address #2 $R_{I2t} = R_{I2t_1}$ See Figure 49	PRQ-614
Diagnosis of I2t_2 setting	$I_{IS(I2t_2)}$	1.95	2.14	2.33	mA	Address #2 $R_{I2t} = R_{I2t_2}$ See Figure 49	PRQ-615
Diagnosis of I2t_3 setting	$I_{IS(I2t_3)}$	1.43	1.58	1.74	mA	Address #2 $R_{I2t} = R_{I2t_3}$ See Figure 49	PRQ-616
Diagnosis of I2t_4 setting	$I_{IS(I2t_4)}$	1.01	1.13	1.26	mA	Address #2 $R_{I2t} = R_{I2t_4}$ See Figure 49	PRQ-617
Diagnosis of I2t_5 setting	$I_{IS(I2t_5)}$	0.70	0.78	0.87	mA	Address #2 $R_{I2t} = R_{I2t_5}$ See Figure 49	PRQ-618
Diagnosis of I2t_6 setting	$I_{IS(I2t_6)}$	0.39	0.47	0.55	mA	Address #2 $R_{I2t} = R_{I2t_6}$ See Figure 49	PRQ-619
Diagnosis of I2t pin open	$I_{IS(I2t_OPEN)}$	0.08	0.15	0.21	mA	Address #2 $R_{I2t} = R_{I2t_OPEN}$ See Figure 49	PRQ-620

(table continues...)

Table 19 (continued) Diagnosis power output stage
 $V_S = 5\text{ V to }20\text{ V}$, $T_J = -40^\circ\text{C to }150^\circ\text{C}$

 Unless otherwise specified typical values: $V_S = 13.5\text{ V}$, $T_J = 25^\circ\text{C}$

 Typical resistive loads connected to the outputs for testing (unless otherwise specified): $R_L = 2.1\ \Omega$

Parameter	Symbol	Values			Unit	Note or condition	P-Number
		Min.	Typ.	Max.			
I2t status							
100% Status of I2t_1	$I_{IS(I2t_1_100\%)}$	2.96	3.41	3.85	mA	¹⁾ Address #3 See Figure 50	PRQ-1382
100% Status of I2t_2	$I_{IS(I2t_2_100\%)}$	2.42	2.79	3.16	mA	¹⁾ Address #3 See Figure 50	PRQ-1388
100% Status of I2t_3	$I_{IS(I2t_3_100\%)}$	1.95	2.24	2.54	mA	¹⁾ Address #3 See Figure 50	PRQ-1395
100% Status of I2t_4	$I_{IS(I2t_4_100\%)}$	1.59	1.83	2.07	mA	¹⁾ Address #3 See Figure 50	PRQ-1399
100% Status of I2t_5	$I_{IS(I2t_5_100\%)}$	1.26	1.46	1.65	mA	¹⁾ Address #3 See Figure 50	PRQ-1402
100% Status of I2t_6	$I_{IS(I2t_6_100\%)}$	1.01	1.16	1.32	mA	¹⁾ Address #3 See Figure 50	PRQ-1405

OCT setting

Diagnosis of OCT pin short	$I_{IS(OCT_SHORT)}$	3.33	3.64	3.94	mA	Address #4 $V_S = 6\text{ V}$ $I_{OCT} = 83.3\ \mu\text{A}$ See Figure 51	PRQ-627
Diagnosis of HOCT setting	$I_{IS(HOCT)}$	2.45	2.72	2.99	mA	Address #4 $I_{OCT} = 50\ \mu\text{A}$ See Figure 51	PRQ-628
Diagnosis of LOCT setting	$I_{IS(LOCT)}$	0.33	0.43	0.52	mA	Address #4 $I_{OCT} = 7.5\ \mu\text{A}$ See Figure 51	PRQ-629
Diagnosis of OCT pin open	$I_{IS(OCT_OPEN)}$	0.08	0.15	0.21	mA	Address #4 $I_{OCT} = 3.8\ \mu\text{A}$ See Figure 51	PRQ-630

(table continues...)

Table 19 (continued) Diagnosis power output stage

$V_S = 5\text{ V to }20\text{ V}$, $T_J = -40^\circ\text{C to }150^\circ\text{C}$

Unless otherwise specified typical values: $V_S = 13.5\text{ V}$, $T_J = 25^\circ\text{C}$

Typical resistive loads connected to the outputs for testing (unless otherwise specified): $R_L = 2.1\ \Omega$

Parameter	Symbol	Values			Unit	Note or condition	P-Number
		Min.	Typ.	Max.			
Digital current sense ratio							
LSB for KILDIS conversion	LSB	117	138	159	mA	1)	PRQ-1458
Digital current sense ratio at - IL = IL11	k_{ILDIS11}	-20%	6750	+20%	-	$I_{L11} = 1.5\text{ A}$ IN = "high" Address #5	PRQ-1338
Digital current sense ratio at - IL = IL12	k_{ILDIS12}	-17.5%	6750	+17.5%	-	$I_{L12} = 3\text{ A}$ IN = "high" Address #5	PRQ-1339
Digital current sense ratio at - IL = IL13	k_{ILDIS13}	-15%	6750	+15%	-	$I_{L13} = 5\text{ A}$ IN = "high" Address #5	PRQ-1340
Digital current sense ratio at - IL = IL14	k_{ILDIS14}	-15%	6750	+15%	-	$I_{L14} = 7.5\text{ A}$ IN = "high" Address #5	PRQ-1341

1) Not subject to production test - specified by design.

11 Application information

Reference	Value	Purpose
R_{PD}	47 k Ω	Output polarization (pull-down). Ensures polarization of the device output to distinguish between open load and short to V_S in OFF diagnosis
R_{OL}	1.5 k Ω	Output polarization (pull-up). Ensures polarization of the device output during open load in OFF diagnosis
C_{OUT}	10 nF ¹⁾	Protection of the device output during ESD events and BCI
T_1	BC 807	Switches the battery voltage for open load in OFF diagnosis
C_{VS1}	100 nF	Filtering of voltage spikes on the battery line
C_{VS2}	–	Filtering / buffer capacitor located at V_{BAT} connector
C_{VSGND}	22 nF	Buffer capacitor for fast transients. Recommended in case no battery voltage oscillation filter is present
D_{Z2}	33 V Z-Diode	Suppressor diode. Protection during overvoltage and in case of loss of battery while driving an inductive load
R_{SENSE}	1.2 k Ω	SENSE resistor
R_{IS_PROT}	4.7 k Ω	Protection during overvoltage, reverse polarity, loss of ground. Value to be tuned according to microcontroller specifications
D_{Z1}	7 V Z-Diode	Protection of microcontroller during overvoltage
R_{AD}	4.7 k Ω	Protection of microcontroller ADC input during overvoltage, reverse polarity, loss of ground. Value to be tuned according to microcontroller specifications
C_{SENSE}	220 pF	Sense signal filtering. A time constant $(R_{AD} + R_{IS_PROT}) * C_{SENSE}$ longer than 1 μ s is recommended
R_{GND}	47 Ω	Protection in case of overvoltage and loss of battery while driving inductive loads

1) In case the CLS mode is used, a C_{OUT} of 100 nF is recommended to additionally improve the EMC performance.

11.3 Further application information

- Please contact us for information regarding the pin behavior assessment
- For further information you may contact <http://www.infineon.com/>

12 Package outlines

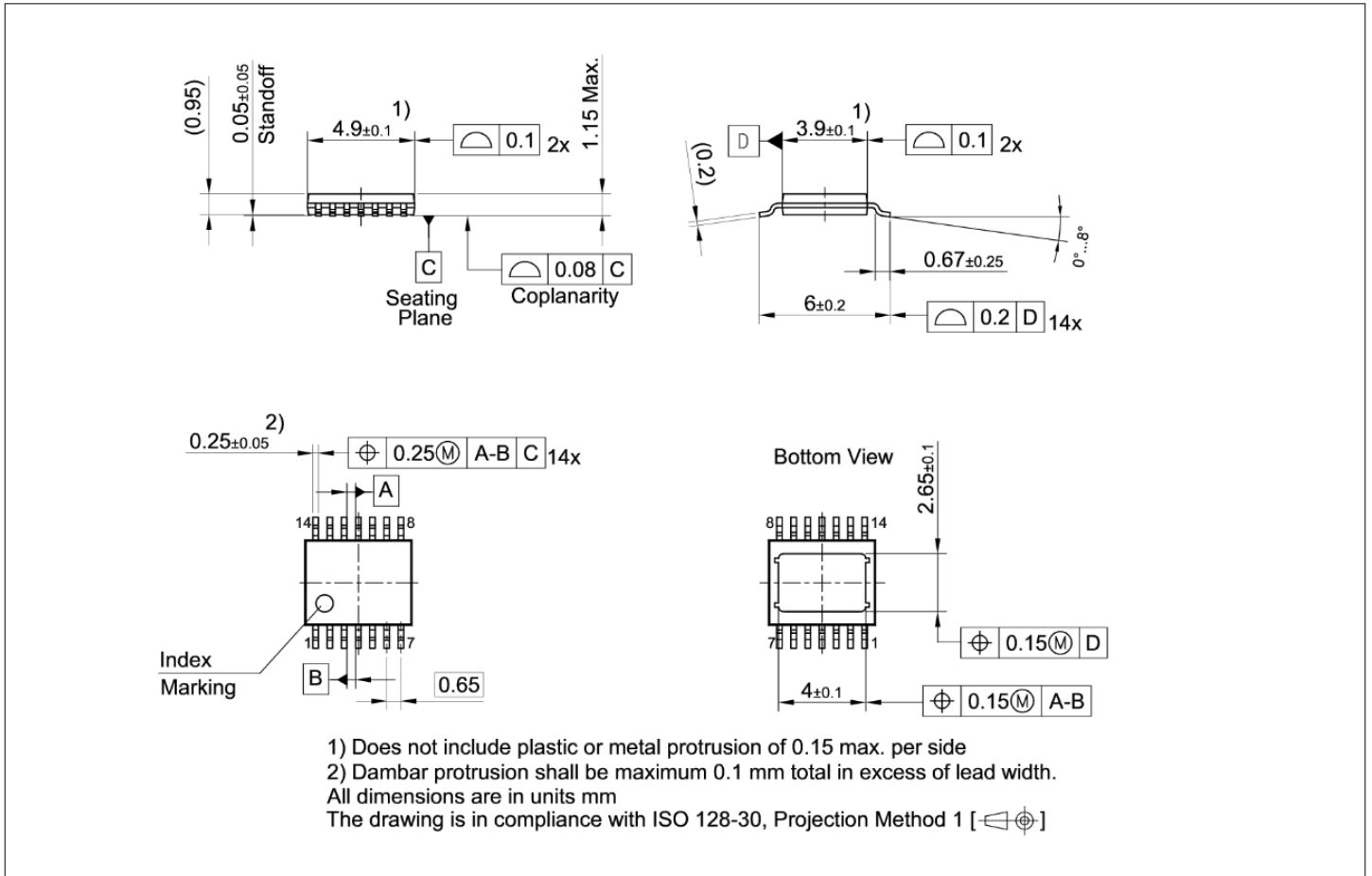

Figure 55 PG-TSDSO-14 (thin (slim) dual small outline 14 pins) package outline

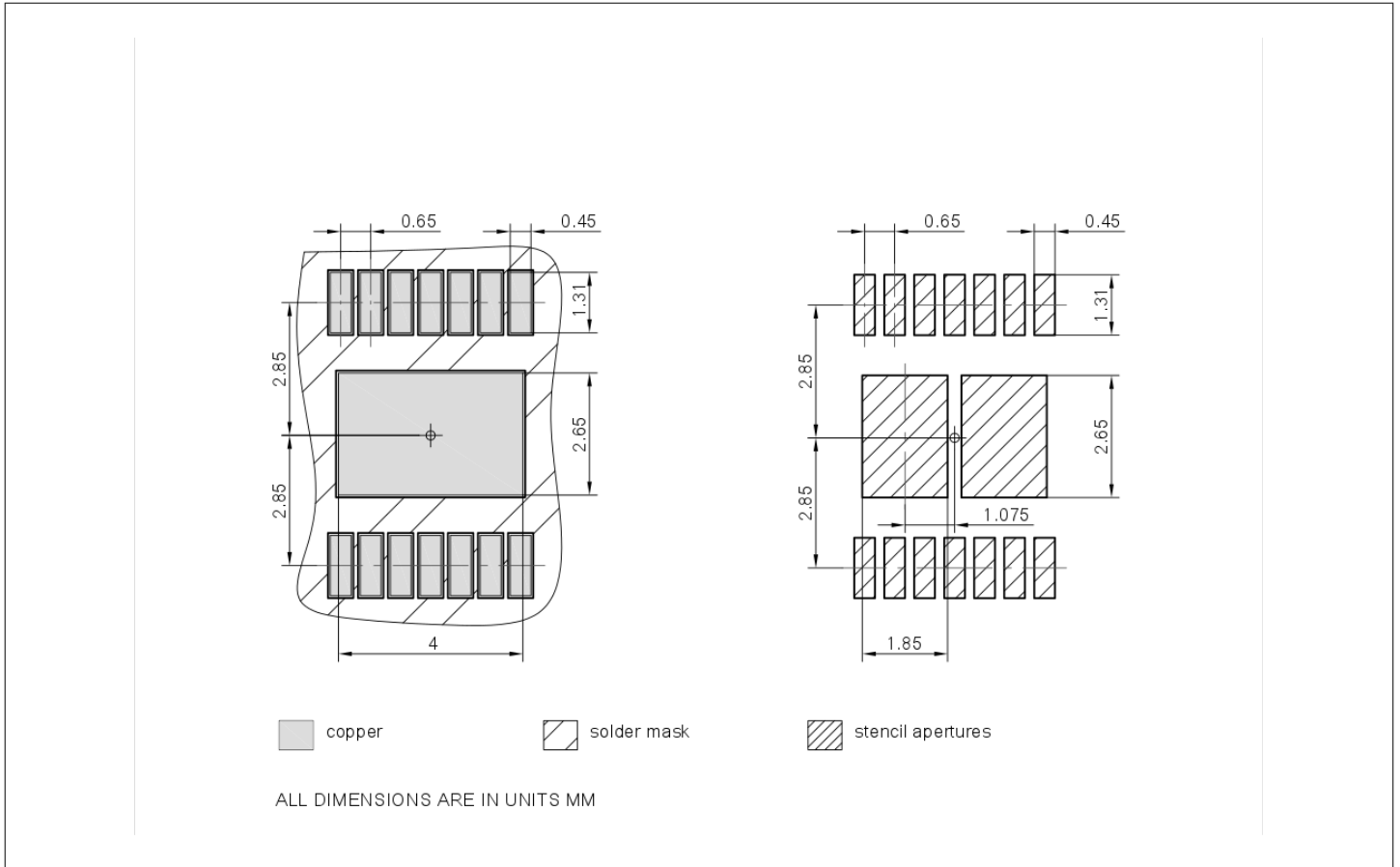

Figure 56 PG-TSDSO-14 (thin (slim) dual small outline 14 pins) package pads and stencil

To meet the world-wide customer requirements for environmentally friendly products and to be compliant with government regulations the device is available as a green product. Green products are RoHS-Compliant (i.e Pb-free finish on leads and suitable for Pb-free soldering according to IPC/JEDEC J-STD-020).

13 Revision history

Document version	Date of release	Description of changes
Rev. 1.00	2023-12-06	Datasheet available

Trademarks

All referenced product or service names and trademarks are the property of their respective owners.

Edition 2023-12-06

Published by

Infineon Technologies AG

81726 Munich, Germany

© 2023 Infineon Technologies AG

All Rights Reserved.

Do you have a question about any aspect of this document?

Email: erratum@infineon.com

Document reference

IFX-tse1615989668687

Important notice

The information given in this document shall in no event be regarded as a guarantee of conditions or characteristics ("Beschaffheitsgarantie").

With respect to any examples, hints or any typical values stated herein and/or any information regarding the application of the product, Infineon Technologies hereby disclaims any and all warranties and liabilities of any kind, including without limitation warranties of non-infringement of intellectual property rights of any third party.

In addition, any information given in this document is subject to customer's compliance with its obligations stated in this document and any applicable legal requirements, norms and standards concerning customer's products and any use of the product of Infineon Technologies in customer's applications.

The data contained in this document is exclusively intended for technically trained staff. It is the responsibility of customer's technical departments to evaluate the suitability of the product for the intended application and the completeness of the product information given in this document with respect to such application.

Warnings

Due to technical requirements products may contain dangerous substances. For information on the types in question please contact your nearest Infineon Technologies office.

Except as otherwise explicitly approved by Infineon Technologies in a written document signed by authorized representatives of Infineon Technologies, Infineon Technologies' products may not be used in any applications where a failure of the product or any consequences of the use thereof can reasonably be expected to result in personal injury.

X-ON Electronics

Largest Supplier of Electrical and Electronic Components

Click to view similar products for [Power Switch ICs - Power Distribution](#) category:

Click to view products by [Infineon](#) manufacturer:

Other Similar products are found below :

[TLE6232GP](#) [VND5E004ATR-E](#) [FPF1018](#) [DS1222](#) [SZNCP3712ASNT3G](#) [NCP45520IMNTWG-H](#) [VND5004ATR-E](#) [AP22811BW5-7](#)
[SZNCP3712ASNT1G](#) [DML1008LDS-7](#) [VND7012AYTR](#) [NCV459MNWTBG](#) [NCP4545IMNTWG-L](#) [NCV8412ASTT1G](#)
[NCV8412ASTT3G](#) [FPF2260ATMX](#) [NCP45780IMN24RTWG](#) [AP2151AMP-13](#) [NCP45540IMNTWG-L](#) [XC8111AA01MR-G](#)
[NCP45650IMNTWG](#) [DK5V100R20S](#) [BTS7020-2EPA](#) [BTT6100-2ERA](#) [BTS71220-4ESA](#) [DK5V100R15M](#) [WS3220C9-9/TR](#) [AW32405CSR](#)
[BTT6030-2ERA](#) [TLE75602-ESH](#) [BTS5200-4EKA](#) [DK5V150R25M](#) [DK5V45R25](#) [DK5V100R25S](#) [AW35206FOR](#) [BTS7120-2EPA](#)
[TLE75008-ESD](#) [BTS7040-1EPA](#) [BTT6030-1ERA](#) [DK5V60R10S](#) [DK5V45R25S](#) [DK5V60R10](#) [DK5V45R15S](#) [DK5V100R15S](#) [DK5V85R15](#)
[WS3241C-12/TR](#) [WS4622C-4/TR](#) [TPS22953QDQCRQ1](#) [TPS22998RYZR](#) [SY7076QMC](#)