

**CONNECTOR  
 DESIGNATORS**

**A-F-H**

**J-L-S**

**ROTATABLE  
 COUPLING**

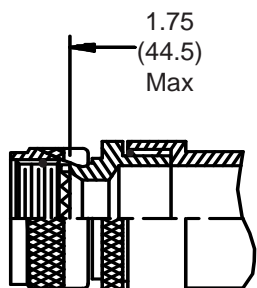
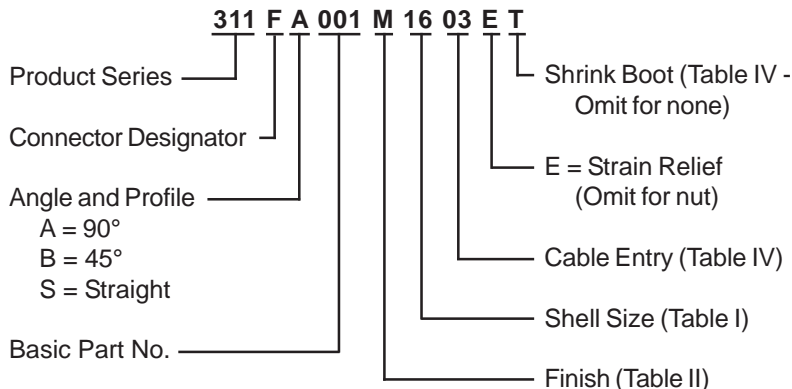

**STYLE 2  
 (STRAIGHT  
 See Note 5)**

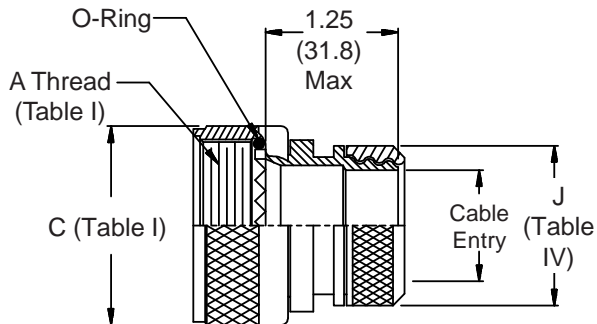

**STYLE E  
 STRAIN RELIEF**

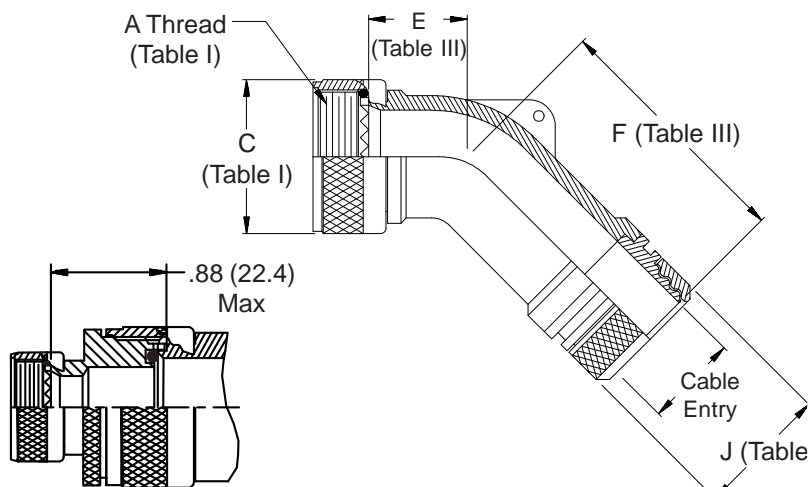
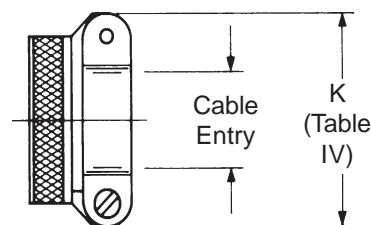

**STYLE 2  
 (45° & 90°  
 See Note 5)**

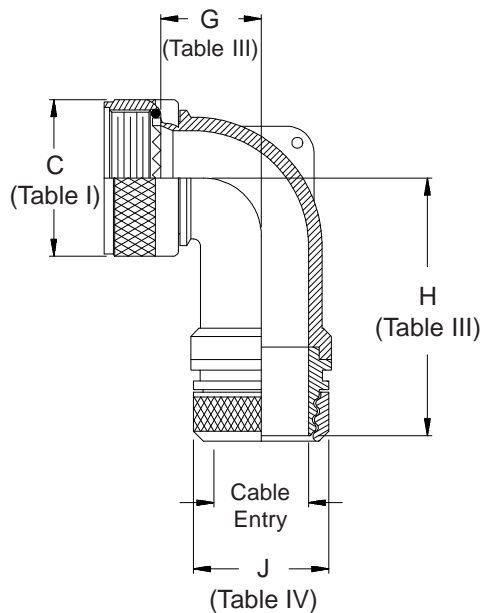

**311-001**  
**Lamp-Base Thread EMI/RFI Shrink Boot Adapter**  
 with Strain Relief and Optional Shrink Boot  
 Rotatable Coupling - Low Profile



See inside back cover fold-out  
 or pages 13 and 14  
 for unabridged Tables I and II.

**TABLE III: DIMENSIONS**

| SHELL SIZE |    | E            | F            | G            | H            |
|------------|----|--------------|--------------|--------------|--------------|
| A-F-J-L-S  | H  | Max          | Max          | Max          | Max          |
| 08         | 09 | .457 (11.6)  | 1.630 (41.4) | .500 (12.7)  | 1.640 (41.7) |
| 10         | 11 | .520 (13.2)  | 1.690 (42.9) | .595 (15.1)  | 1.760 (44.7) |
| 12         | 13 | .582 (14.8)  | 1.750 (44.5) | .610 (15.5)  | 1.780 (45.2) |
| 14         | 15 | .645 (16.4)  | 1.840 (46.7) | .700 (17.8)  | 1.850 (47.0) |
| 16         | 17 | .738 (18.7)  | 1.950 (49.5) | .885 (22.5)  | 1.940 (49.3) |
| 18         | 19 | .926 (23.5)  | 2.140 (54.4) | .975 (24.8)  | 2.110 (53.6) |
| 20         | 21 | .926 (23.5)  | 2.140 (54.4) | .975 (24.8)  | 2.110 (53.6) |
| 22         | 23 | 1.020 (25.9) | 2.290 (58.2) | 1.125 (28.6) | 2.220 (56.4) |
| 24         | 25 | 1.020 (25.9) | 2.290 (58.2) | 1.125 (28.6) | 2.220 (56.4) |
| 28         |    | 1.145 (29.1) | 2.340 (59.4) | 1.225 (31.1) | 2.390 (60.7) |
| 32         |    | 1.207 (30.7) | 2.440 (62.0) | 1.575 (40.0) | 2.640 (67.1) |
| 36         |    | 1.238 (31.4) | 2.530 (64.3) | 1.775 (45.1) | 2.640 (67.1) |

**TABLE IV: CABLE ENTRY AND SHRINK BOOT**

| Dash No. | J Max        | K Max        | Cable Entry Max | Shrink Boot |
|----------|--------------|--------------|-----------------|-------------|
| 01       | .448 (11.4)  | .781 (19.8)  | .125 (3.2)      | n/a         |
| 02       | .515 (13.1)  | .968 (24.6)  | .250 (6.4)      | 770-001S103 |
| 03       | .640 (16.3)  | 1.046 (26.6) | .375 (9.5)      | 770-001S103 |
| 04       | .765 (19.4)  | 1.156 (29.4) | .500 (12.7)     | 770-001S104 |
| 05       | .920 (23.4)  | 1.219 (31.0) | .625 (15.9)     | 770-001S104 |
| 06       | 1.015 (25.8) | 1.343 (34.1) | .750 (19.1)     | 770-001S105 |
| 07       | 1.140 (29.0) | 1.469 (37.3) | .875 (22.2)     | 770-001S106 |
| 08       | 1.265 (32.1) | 1.594 (40.5) | 1.000 (25.4)    | 770-001S106 |
| 09       | 1.432 (36.4) | 1.719 (43.7) | 1.125 (28.6)    | 770-001S107 |
| 10       | 1.515 (38.5) | 1.844 (46.8) | 1.250 (31.8)    | 770-001S107 |
| 11       | 1.640 (41.7) | n/a          | 1.375 (34.9)    | 770-001S108 |
| 12       | 1.765 (44.8) | n/a          | 1.500 (38.1)    | 770-001S108 |
| 13       | 2.015 (51.2) | n/a          | 1.750 (44.5)    | 770-001S108 |

1. Cable Entry is defined as the accomodation range for the wire bundle or cable. Dimensions shown are not intended for inspection criteria.
2. See Shrink Boot Reference Information (page 40).
3. Metric dimensions (mm) are indicated in parentheses.
4. O-Rings not supplied with Connector Designator A.
5. When maximum entry (page 21) is exceeded, Style 2 will be supplied. Dimensions E, F, G & H will not apply. Please consult factory.

**TABLE II - STANDARD FINISHES**

| GLENAIR SYMBOL FINISH |   |
|-----------------------|---|
| B                     | Cadmium Plate, Olive Drab                         |
| M                     | Electroless Nickel                                |
| NF                    | Cadmium Plate, Olive Drab Over Electroless Nickel |

See Inside Back Cover for Complete Finish Information and Additional Finish Options

**TABLE I - BACKSHELL INTERFACE DIMENSIONS**

| CONNECTOR DESIGNATOR |    |    |    |         |        |        |        |         |    |         | A THREAD*        | B            | C            | D            | E            |
|----------------------|----|----|----|---------|--------|--------|--------|---------|----|---------|------------------|--------------|--------------|--------------|--------------|
| A                    | C* | D  | E  | F       | G      | H      | J      | K       | L  | S       | REFERENCE        | DIA MAX      | DIA MAX      | DIA MAX      | DIA MAX      |
|                      |    | 08 | 08 | 08 [9]  |        |        |        | 08      | 08 | 08      | 7/16 - 28 UNEF   | .590 (15.)   | .650 (16.5)  | .770 (19.6)  | .690 (17.5)  |
|                      |    |    |    |         |        | 09 [A] |        |         |    |         | M12 x 1 - 6H     | .650 (16.5)  | .770 (19.6)  |              | .940 (24.8)  |
| 08                   |    |    |    |         |        |        | 08 [A] | 10      |    |         | 1/2 - 20 UNF     | .650 (16.5)  | .650 (16.5)  |              | .690 (17.5)  |
|                      |    |    |    |         |        |        |        |         |    |         | 1/2 - 28 UNEF    | .650 (16.5)  | .770 (19.6)  | .770 (19.6)  |              |
| 03                   |    | 10 | 10 | 10 [11] |        |        |        |         |    |         | 9/16 - 24 UNEF   | .720 (18.3)  | .770 (19.6)  | .890 (22.6)  | .820 (20.8)  |
|                      |    |    |    |         |        | 11 [B] |        |         |    |         | M15 x 1 - 6H     | .770 (19.6)  | .820 (20.8)  |              | 1.060 (26.9) |
|                      |    |    |    |         |        |        |        |         |    |         | 5/8 - 24 UNEF    | .770 (19.6)  | .770 (19.6)  | .890 (22.6)  | .820 (20.8)  |
| 10                   |    |    |    |         |        |        |        | 10 [B]  |    |         | 5/8 - 28 UN      | .770 (19.6)  | .890 (22.6)  |              |              |
|                      |    | 12 |    | 12 [13] |        |        |        |         |    |         | 11/16 - 24 UNEF  | .840 (21.3)  | .890 (22.6)  | 1.020 (25.9) | .940 (23.8)  |
|                      |    |    |    |         |        | 13 [C] |        |         |    |         | M18 x 1 - 6H     | .890 (22.6)  | .940 (23.9)  |              | 1.170 (29.7) |
| 12 [7]               | 12 |    | 12 |         | 11 [A] |        |        | 14 [15] |    |         | 3/4 - 20 UNEF    | .970 (24.6)  | .940 (23.9)  | 1.020 (25.9) | .940 (23.8)  |
|                      |    | 14 | 14 | 14 [15] |        |        |        |         |    |         | 13/16 - 20 UNEF  | .970 (24.6)  | 1.020 (29.2) | 1.150 (29.2) | 1.060 (26.9) |
|                      |    |    |    |         |        | 15 [D] |        |         |    |         | M22 x 1 - 6H     | 1.030 (26.2) | 1.070 (26.2) |              | 1.290 (32.7) |
| 14 [12]              | 14 |    |    |         |        | 13 [B] |        |         |    | 16 [17] | 7/8 - 20 UNEF    | 1.090 (27.7) | 1.020 (25.9) | 1.150 (29.2) | 1.060 (26.9) |
|                      |    |    |    |         |        |        |        | 14 [D]  |    |         | 7/8 - 28 UN      | 1.030 (26.2) | 1.150 (29.2) |              |              |
|                      |    | 16 | 16 | 16 [17] |        |        |        |         |    |         | 15/16 - 20 UNEF  | 1.090 (27.7) | 1.150 (29.2) | 1.260 (32.0) | 1.170 (29.7) |
|                      |    |    |    |         |        | 17 [E] |        |         |    |         | M25 x 1 - 6H     | 1.150 (29.2) | 1.210 (30.7) |              | 1.420 (36.1) |
| 16 [19]              | 16 |    |    |         |        | 15 [C] |        |         |    | 18      | 1 - 20 UNEF      | 1.220 (29.2) | 1.210 (30.7) | 1.230 (31.2) | 1.170 (29.7) |
|                      |    |    |    |         |        |        |        | 16 [E]  |    |         | 1 - 28 UN        | 1.150 (29.2) | 1.360 (34.5) |              |              |
| 18 [27]              |    | 18 | 18 | 18 [19] |        |        |        |         |    | 18      | 1 1/16 - 18 UNEF | 1.220 (31.0) | 1.230 (31.2) | 1.400 (35.6) | 1.290 (32.7) |
|                      |    |    |    |         |        | 19 [F] |        |         |    |         | M28 x 1 - 6H     | 1.280 (32.5) | 1.360 (34.5) |              | 1.540 (39.1) |
|                      | 18 |    |    |         |        | 17 [D] |        |         |    | 20      | 1 1/8 - 18 UNEF  | 1.340 (34.0) | 1.360 (34.5) | 1.360 (34.5) |              |
|                      |    |    |    |         |        |        |        | 18 [F]  |    |         | 1 1/8 - 28 UN    | 1.280 (32.5) | 1.480 (37.6) |              |              |
| 20 [37]              |    | 20 | 20 | 20 [21] |        |        |        |         |    | 20      | 1 3/16 - 18 UNEF | 1.340 (34.0) | 1.360 (34.5) | 1.530 (38.9) | 1.420 (36.0) |
|                      |    |    |    |         |        | 21 [G] |        |         |    |         | M31 x 1 - 6H     | 1.410 (35.8) | 1.480 (37.6) |              | 1.670 (42.4) |
|                      | 20 |    |    |         |        | 19 [E] |        |         |    | 22      | 1 1/4 - 18 UNEF  | 1.470 (37.3) | 1.530 (38.9) | 1.480 (37.6) |              |
|                      |    |    |    |         |        |        |        | 20 [G]  |    |         | 1 1/4 - 28 UN    | 1.410 (35.8) | 1.600 (40.6) |              |              |
| 22                   |    | 22 | 22 | 22 [23] |        |        |        |         |    | 22      | 1 5/16 - 18 UNEF | 1.470 (37.3) | 1.480 (37.6) | 1.600 (40.6) | 1.540 (39.1) |
|                      |    |    |    |         |        | 23 [H] |        |         |    |         | M34 x 1 - 6H     | 1.530 (38.9) | 1.600 (40.6) |              | 2.010 (51.1) |
|                      | 22 |    |    |         |        |        |        |         |    | 24      | 1 3/8 - 18 UNEF  | 1.590 (40.4) |              | 1.600 (40.6) |              |
|                      |    |    |    |         |        |        |        | 22 [H]  |    |         | 1 3/8 - 28 UN    | 1.530 (38.9) | 1.730 (43.9) |              |              |
| 24                   |    | 24 | 24 | 24 [25] | 23 [F] |        |        |         |    | 24      | 1 7/16 - 18 UNEF | 1.590 (40.4) | 1.730 (43.9) | 1.940 (49.3) | 1.660 (42.2) |
|                      |    |    |    |         |        | 25 [J] |        |         |    |         | M37 x 1 - 6H     | 1.660 (42.2) | 1.700 (43.2) |              | 2.120 (53.8) |
| 61                   |    |    |    |         |        |        |        |         |    |         | 1 1/2 - 18 UNEF  | 1.660 (42.2) | 1.670 (42.4) |              |              |
|                      |    |    |    |         |        |        |        | 24 [J]  |    |         | 1 1/2 - 28 UN    | 1.660 (42.2) | 1.940 (49.3) |              |              |
|                      |    |    |    |         | 25 [G] |        |        |         |    |         | 1 9/16 - UNEF    |              | 1.820 (46.2) |              |              |
|                      | 24 |    |    |         |        |        |        |         |    | 28      | 1 5/8 - UNEF     | 1.840 (46.7) |              | 1.940 (49.3) |              |
| 28                   |    |    |    |         |        |        |        |         |    |         | 1 3/4 - 18 UNS   | 1.970 (50.0) | 1.970 (50.0) |              | 2.010 (51.1) |
|                      | 28 |    |    |         |        | 29 [H] |        |         |    | 32      | 1 7/8 - 16 UN    | 2.090 (53.1) | 2.190 (55.6) | 2.190 (55.6) |              |
| 32                   |    |    |    |         |        |        |        |         |    |         | 2 - 18 UNS       | 2.280 (57.9) | 2.220 (56.4) |              | 2.260 (57.4) |
|                      | 32 |    |    |         |        | 33 [J] |        |         |    |         | 2 1/16 - 16 UNS  | 2.340 (59.4) | 2.440 (62.0) | 2.440 (62.0) |              |
|                      |    |    |    |         |        |        |        |         |    | 36      | 2 1/8 - 16 UN    | 2.340 (59.4) |              | 2.440 (62.0) |              |
| 36                   |    |    |    |         |        |        |        |         |    |         | 2 1/4 - 16 UN    | 2.530 (64.3) | 2.47 (62.7)  |              | 2.530 (64.3) |
|                      | 36 |    |    |         |        |        |        |         |    |         | 2 5/16 - 16 UNS  | 2.590 (65.8) |              | 2.690 (68.3) |              |
|                      |    |    |    |         |        |        |        |         |    | 40      | 2 3/8 - 16 UN    | 2.590 (65.8) |              | 2.690 (68.3) |              |
| 40                   |    |    |    |         |        |        |        |         |    |         | 2 1/2 - 16 UN    | 2.780 (70.6) | 2.720 (69.1) |              | 3.040 (77.2) |
|                      | 40 |    |    |         |        |        |        |         |    |         | 2 5/8 - 16 UN    | 2.910 (73.9) |              | 2.930 (74.4) |              |
| 44                   |    |    |    |         |        |        |        |         |    |         | 2 3/4 - 16 UN    | 3.030 (77.0) | 2.970 (75.4) |              |              |
|                      | 44 |    |    |         |        |        |        |         |    |         | 2 7/8 - 16 UN    | 3.160 (80.3) |              |              |              |
| 48                   |    |    |    |         |        |        |        |         |    |         | 3 - 16 UN        | 3.220 (81.8) | 3.220 (81.8) |              |              |
|                      | 48 |    |    |         |        |        |        |         |    |         | 3 1/16 - 16 UN   | 3.410 (86.6) |              |              |              |

\* Code C, MIL-C-22992, Left-Hand Thread. Connector designations depicted thus [ ] are for reference only and are not to be used in part number development.

**BACKSHELL INTERFACE STANDARDS (See pages 15-17 for more information)**

| DESIG. SPEC. | SERIES                | DESIG. SPEC. | SERIES                 | DESIG. SPEC. | SERIES                  | DESIG. SPEC. | SERIES     |
|--------------|-----------------------|--------------|------------------------|--------------|-------------------------|--------------|------------|
| A            | MIL-DTL-5015 MS3400   | A            | PATT 602               | G            | MIL-C-28840             | L            | EN3372     |
|              | MIL-DTL-26482 2       | B            | MIL-DTL-5015 MS3100    | H            | MIL-DTL-38999 III & IV  |              | JN 1003    |
|              | AS81703 3             | C            | MIL-C-22992 MS173XX    |              | EN3645                  |              | LN 29729   |
|              | MIL-DTL-83723 I & III | D            | MIL-DTL-26482 1        | J            | MIL-C-81511 1, 2, 3 & 4 |              | NFC93422   |
|              | 40M39569              | E            | MIL-DTL-26500 Aluminum |              | VG95329                 |              | PAN 6433-2 |
|              | DEF 5326-3            | F            | MIL-DTL-38999 I & II   | K            | MIL-DTL-83723 I         |              | PATT 615   |
|              | EN 2997, 3646         |              | 40M38277               |              |                         |              | VG 96912   |
|              | ESC 10, 11            |              | PAN 6433-1             |              |                         | S            | PATT 105   |
|              | LN 29504              |              | PATT 614               |              |                         |              | PATT 603   |
|              | NFC93422 HE302        |              | PATT 616               |              |                         |              | PATT 608   |
|              | PAN 6432-1, -2        |              | NFC93422 HE308, 9      |              |                         |              |            |



## Reference Information Standard Materials and Finishes

**TABLE II - STANDARD FINISHES**

| GLENAIR SYMBOL | M85049 SYMBOL REFERENCE ONLY | FINISH   | SPECIFICATION(S)  |
|----------------|------------------------------|--|---|
| A              |                              | Cadmium Plate, Bright                                    | AMS-QQ-P-416, Type I, Class 2   |
| B              |                              | Cadmium Plate, Olive Drab                                | AMS-QQ-P-416, Type II, Class 3  |
| C*             | A                            | Anodize, Black   | AMS-A-8625, Type II, Class 2  |
| G*             |                              | Hard Coat, Anodic  | AMS-A-8625, Type III, Class 1   |
| J              |                              | Iridite, Gold Over Cadmium Plate Over Electroless Nickel | MIL-C-5541, Class 3 AMS-QQ-P-416, Type II, Class 3 over AMS-C-26074, Class 4, Grade B |
| LF             |                              | Cadmium Plate, Bright Over Electroless Nickel            | 1000 Hour Corrosion Resistance  |
| M              | N                            | Electroless Nickel                                       | AMS-C-26074, Class 4, Grade B   |
| N              |                              | Cadmium Plate, Olive Drab Over Electroless Nickel        | AMS-QQ-P-416, Type II, Class 3 over Electroless Nickel AMS-C-26074                    |
| NC             |                              | Zinc Cobalt, Dark Olive Drab                             | 96 Hour Corrosion Resistance  |
| NF             | W                            | Cadmium Plate, Olive Drab Over Electroless Nickel        | 1000 Hour Corrosion Resistance  |
| T              |                              | Cadmium Plate, Bright Over Electroless Nickel            | AMS-QQ-P-416, Type I, Class 3<br>ASTMB 733-90, SC2, Type I, Class 5, MIL-C-26074***   |
| U              |                              | Cadmium Plate, Black                                     | AMS-QQ-P-416, Type II, Class 3  |
| ZU**           |                              | Cadmium Plate, Black                                     | AMS-QQ-P-416, Type II, Class 3  |
| ZN             |                              | Zinc-Nickel Alloy, Olive Drab                            | ASTMB 841-91, Over Electroless Nickel 1000 Hour Salt Spray                            |

\* Anodize finish; not suitable for EMI Shielding or grounding applications.  
 \*\* Applicable to corrosion resisting steel backshells and accessories. Consult factory for other available finishes.

The following standard materials are used for the majority of Glenair backshells and connector accessories. However, backshell components are not limited to those items listed, but are representative of

the elements used in Glenair's general accessory products. Contact Glenair for applicable specifications on items not listed below.

### STANDARD MATERIALS - BACKSHELLS AND ACCESSORIES

| COMPONENT  | MATERIAL                     | SPECIFICATION                         |
|--|------------------------------|---------------------------------------|
| Machined components: such as backshell bodies, fabricated elbows, protective covers, rotatable couplers, dummy stowage receptacles, lock nuts, G-spring support rings, EMI ground rings, grommet followers, etc. | Aluminum                     | AMS-QQ-A-200<br>ASTMB221, 209         |
| Die cast components: such as angular backshells, strain relief backshells, strain relief bodies, strain relief saddles, special EMI ground rings, etc.   | Aluminum                     | QQ-A-591<br>ASTMB85, 26               |
| Backshells or strain reliefs: available in optional corrosion resisting steel; and hardware: such as screws, washers, rivets, wire rope, sash chain, band straps, etc.   | Corrosion Resisting Steel    | ASTMA582 (300 Series)<br>AMS-QQ-S-763 |
| Elastomeric seals: such as O-rings, cable jacket seals, grommets, etc.   | Silicone                     | A-A-59588                             |
|  | Fluorosilicone               | MIL-DTL-25988                         |
| Anti-friction and thrust washers   | Fluoropolymer                | TFE                                   |
| Anti-rotation device   | Corrosion Resistant Material | N/A                                   |

#### BODY STRAP

Glenair offers an optional stainless steel body strap for attaching protective covers as illustrated. To specify body strap, add suffix letter C to the end of the part number. For example 360AS001M1610M6C.

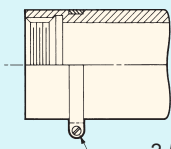

2-56 Screw and Nut

#### NOTES

On all length callouts, tolerance is  $\pm .060$  unless otherwise specified.

Unless otherwise specified, the following other dimensional tolerances will apply:

- .xx =  $\pm .03$  (0.8)
- .xxx =  $\pm .015$  (0.4)
- Lengths =  $\pm .060$  (1.52)
- Angles =  $\pm 5^\circ$

Metric dimensions (mm) are indicated in parentheses

**NOTE: For your convenience these tables have been reproduced inside the back cover fold-out.**

## Glenair Backshell and Accessory Material and Finish Options

Backshell and accessory base materials, plating options, specifications and codes

| Code       | Material        | Finish                     | Finish Specification                                      |
|------------|-----------------|----------------------------|---|
| <b>A</b>   | Aluminum        | Cadmium, No Chromate       | SAE-AMS-QQ-P-416 Type I Class 3                           |
| <b>AB</b>  | Marine Bronze   | Unplated                   |   |
| <b>AL</b>  | Aluminum        | AlumiPlate, Clear Chromate | MIL-DTL-83488, Class 2, Type II over electroless nickel   |
| <b>B</b>   | Aluminum        | Cadmium, Olive Drab        | SAE-AMS-QQ-P-416 Type II Class 3                          |
| <b>C</b>   | Aluminum        | Anodize, Black             | AMS-A-8625 Type II Class 2                                |
| <b>E</b>   | Aluminum        | Chem Film                  | MIL-DTL-5541 Type 1 Class 3                               |
| <b>G</b>   | Aluminum        | Anodize, Hardcoat          | AMS-A-8625 Type III, Class 1, .001" thick                 |
| <b>J</b>   | Aluminum        | Cadmium, Gold              | SAE-AMS-QQ-P-416 Type II, Class 2 over electroless nickel |
| <b>JF</b>  | Aluminum        | Cadmium, Gold              | SAE-AMS-QQ-P-416 Type II, Class 2 over electroless nickel |
| <b>LF</b>  | Aluminum        | Cadmium, Clear             | SAE-AMS-QQ-P-416 Type II Class 2 over electroless nickel  |
| <b>M</b>   | Aluminum        | Electroless Nickel         | AMS-C-26074 Class 4 Grade B; ASTM-B-733, SC 2, Type IV    |
| <b>MT</b>  | Aluminum        | Nickel-PTFE                | AMS2454   |
| <b>N</b>   | Aluminum        | Cadmium, Olive Drab        | SAE-AMS-QQ-P-416 Type II Class 3 over electroless nickel  |
| <b>NC</b>  | Aluminum        | Zinc-Cobalt, Olive Drab    | ASTM B 840 Grade 6 Type D over electroless nickel         |
| <b>NF</b>  | Aluminum        | Cadmium, Olive Drab        | SAE-AMS-QQ-P-416 Type II Class 2 over electroless nickel  |
| <b>P</b>   | Stainless Steel | Electrodeposited Nickel    | SAE-AMS-QQ-N-290 Class 1 Grade F                          |
| <b>T</b>   | Aluminum        | Cadmium, No Chromate       | SAE-AMS-QQ-P-416 Type I Class 3                           |
| <b>TP2</b> | Titanium        | Electrodeposited Nickel    | SAE-AMS-QQ-N-290 Class 1 Grade F                          |
| <b>U</b>   | Aluminum        | Cadmium, Black             | SAE-AMS-QQ-P-416 Type I Class 3                           |
| <b>UC</b>  | Aluminum        | Zinc-Cobalt, Black         | ASTM B 840 Grade 6 Type D over electroless nickel         |
| <b>UCR</b> | Aluminum        | Zinc-Cobalt, Black         | ASTM B 840 Grade 6 Type D over electroless nickel         |
| <b>UF</b>  | Aluminum        | Cadmium, Black             | SAE-AMS-QQ-P-416 Type II Class 2 over electroless nickel  |
| <b>XAL</b> | Composite       | AlumiPlate                 | MIL-DTL-86448, Class 2, Type II over electroless nickel   |
| <b>XB</b>  | Composite       | Unplated Black             |   |
| <b>XM</b>  | Composite       | Electroless Nickel         | AMS-C-26074   |
| <b>XMT</b> | Composite       | Nickel-PTFE                | GMS-002 Class 2 Type II                                   |
| <b>XO</b>  | Composite       | Unplated Light Brown       |   |
| <b>XW</b>  | Composite       | Cadmium, Olive Drab        | SAE-AMS-QQ-P-416 Type II Class 3 over electroless nickel  |
| <b>XZN</b> | Composite       | Zinc-Nickel, Black         | ASTM B841 Grade 5 over electroless nickel                 |
| <b>Z1</b>  | Stainless Steel | Passivate                  | SAE-AMS-SAE-AMS-QQ-P-35 Type VI                           |
| <b>Z2</b>  | Aluminum        | Gold                       | MIL-DTL-45204 Class 1 over electroless nickel             |
| <b>ZC</b>  | Stainless Steel | Zinc-Cobalt, Black         | ASTM-B840, Grade 6  |
| <b>ZCR</b> | Stainless Steel | Zinc-Cobalt, Black         | ASTM-B840, Grade 6  |
| <b>ZL</b>  | Stainless Steel | Electrodeposited Nickel    | SAE-AMS-QQ-N-290 Class 1 Grade F                          |
| <b>ZM</b>  | Stainless Steel | Electroless Nickel         | AMS-C-26074 Class 1 Grade A                               |
| <b>ZMT</b> | Stainless Steel | Nickel-PTFE                | GMF-002 Type II Class 3                                   |
| <b>ZN</b>  | Aluminum        | Zinc-Nickel, Olive Drab    | ASTM B841 Grade 5 over electroless nickel                 |
| <b>ZNU</b> | Aluminum        | Zinc-Nickel, Black         | ASTM B841 Grade 5 over electroless nickel                 |
| <b>ZR</b>  | Aluminum        | Zinc-Nickel, Black         | ASTM B841 Grade 5 over electroless nickel                 |
| <b>ZU</b>  | Stainless Steel | Cadmium, Black             | SAE-AMS-QQ-P-416 Type II Class 3                          |
| <b>ZW</b>  | Stainless Steel | Cadmium, Olive Drab        | SAE-AMS-QQ-P-416 Type II Class 2 over electroless nickel  |

## X-ON Electronics

Largest Supplier of Electrical and Electronic Components

*Click to view similar products for [Circular MIL Spec Strain Reliefs & Adapters](#) category:*

*Click to view products by [Glenair](#) manufacturer:*

Other Similar products are found below :

[896227-000](#) [899170S004](#) [0113-023-000](#) [6000-063-0022](#) [CS6624-000](#) [620AB038Z136](#) [620AS001Z108](#) [620AS038Z112](#) [620AS038Z120](#)  
[620AS038Z132](#) [620FB038NF08](#) [620HA038NF09](#) [620HA038NF11](#) [620HA038NF13](#) [620HA038NF25](#) [620HB049NF17](#) [620HS038NF11](#)  
[620HS038Z121](#) [620HS042XM19](#) [620HS042XM25](#) [620HS048B17](#) [620MS064NF12](#) [620MS065Z107](#) [620MS065ZNU06](#) [627-123NF21-11](#)  
[627-125NF23-6](#) [630J041M06H](#) [630J041M20H](#) [637S010NF0212H](#) [637S010NF0416A](#) [640830-000](#) [659943-000](#) [66241-10A](#) [CW0597-000](#)  
[CW0598-000](#) [CW0948-000](#) [CY0122-000](#) [M85049/41-6A W/B](#) [M85049/42-12DS](#) [M85049/47N8](#) [M85049/51-1-14S](#) [M85049/51S16S](#)  
[M85049/60-1N16](#) [M85049/60-2G12W](#) [M85049/69-11N](#) [CZ3661-000](#) [D02922-000](#) [70.360.1628.0](#) [703797-000](#) [705825-000](#)