

DIO8221

Controller for Adaptive 100/120Hz Current Ripple Removing Circuit

Features

- Controller for adaptive 100/120Hz current ripple remover
- Built-in zener diode for input voltage clamping
- VG output voltage high to 10V
- Programmable amplitude of LED current ripple
- Programmable maximum cathode voltage of LED
- Programmable maximum LED current
- Short protection
- Over temperature protection
- SOT23-6 Package

Applications

- LED lighting

Descriptions

DIO8221 is a controller for driving external NMOSFET to remove the 100/120Hz LED current ripple on AC/DC power by a capacitor between VC and GND.

The adaptive technology of DIO8221 ensures minimum power dissipation on NMOSFET while removing LED current ripple.

DIO8221 clamps the input voltage on VIN pin by 37V. DIO8221 allows user to setup maximum LED current, which keeps NMOSFET damaged when LED short or hot-plug.

By sensing the drain voltage of NMOSFET via a resistor between the drain and V_{LMT} pin, DIO8221 allows user to setup the maximum cathode voltage of LED string, which could help limit the power dissipation on chip.

DIO8221 provides two kinds of protection function: it shuts down NMOSFET when LED is shorted and recovers after 40ms. And it provides over thermal protection.

Block Diagram

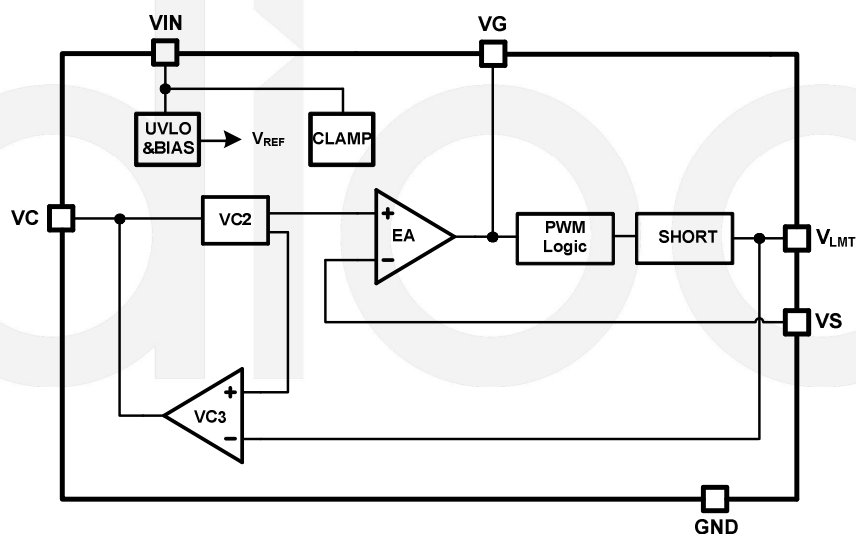

Ordering Information

Order Part Number	Top Marking		T _A	Package	
DIO8221CST6	YW21	Green	-40 to +125°C	SOT23-6	Tape & Reel, 3000

Pin Assignments

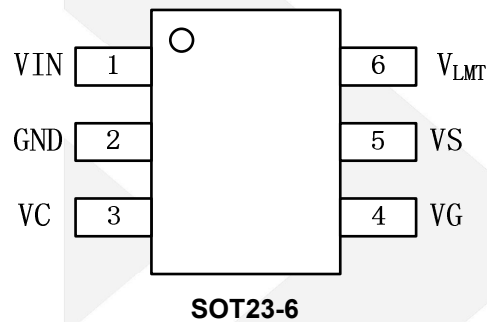

Figure 1 Pin Assignment (Top View)

Pin Definitions

Pin Name	Description
VIN	Power Supply
GND	Power Ground
VC	LED Current Ripple Programming
VG	NMOSFET GATE driving voltage output
VS	LED Current sensing input
V _{LMT}	LED Voltage limit and short protection Programming



DIO8221

Controller for Adaptive 100/120Hz, Current Ripple Removing Circuit

Absolute Maximum Ratings

Stresses beyond those listed under “Absolute Maximum Rating” may cause permanent damage to the device. These are stress ratings only and functional operation of the device at these or any other condition beyond those indicated in the operational sections of the specifications is not implied. Exposure to absolute maximum rating conditions for extended periods may affect device reliability.

Parameter	Rating	Unit
VIN clamp voltage	37	V
VG	20	V
VS, VC, VLMT	-0.3 to 5	V
Junction Temperature	150	°C
Lead Temperature	260	°C
Storage Temperature	-65 to +150	°C
Thermal Resistance / θ_{JA}	170	°C/W

Recommend Operating Conditions

The Recommended Operating Conditions table defines the conditions for actual device operation. Recommended Operating conditions are specified to ensure optimal performance to the datasheet specifications. DIOO does not Recommend exceeding them or designing to Absolute Maximum Ratings.

Parameter	Rating	Unit
Maximum Junction Temperature (T_J)	150	°C





DIO8221

Electrical Characteristics

$T_A = 25^\circ\text{C}$, $V_{IN} = 12\text{V}$, unless otherwise specified.

Symbol	Parameter	Test Conditions	Min	Typ	Max	Unit
V_{IN_CLP}	VIN clamp voltage			37		V
I_{IN}	VIN operation current	$5\text{V} < V_{IN} < 38\text{V}$	0.21	0.24	0.3	mA
V_{THULVO}	VIN startup voltage threshold			16		V
$V_{HYSUVLO}$	VIN startup voltage hysteresis			5		V
V_{VG}	Maximum VG output voltage		6.5	8	9	V
I_{VCST}	VC startup current	VC short to GND when startup	0.9	1.1	1.3	mA
V_{VLMTR}	VLMT reference voltage		1.95	2	2.05	V
V_{D_CLP}	NMOSFET drain voltage limit	Drain voltage of NMOSFET When voltage limit is triggered. $R_{LIMIT}=100\text{K}$.	3.5	4	4.5	V
V_{TH_SHORT}	Short protection threshold	Drain voltage of NMOSFET When short is triggered. $R_{LIMIT}=100\text{K}$.	5.5	6	7	V
T_{SPD}	Short protection delay time			70		μs
T_{SPH}	Short protection hold time			40		ms
V_{VS}	VS voltage limit		0.18	0.2	0.22	V

Specifications subject to change without notice.



Controller for Adaptive 100/120Hz, Current Ripple Removing Circuit

Typical System Characteristics

$V_{IN}=85V\sim 264V_{AC}$, $V_{OUT}=36V$, $I_{OUT}=1A$, $C_{OUT}=470\mu F/50V*4$, $T_A = 25^{\circ}C$

Efficiency Comparison with vs. without DIO8221

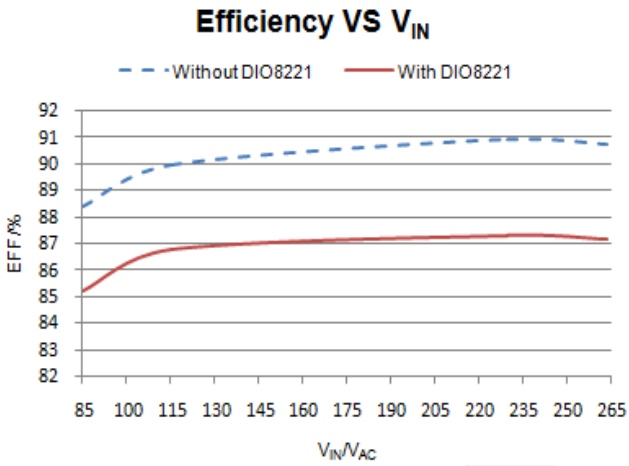

Line Input arcing test

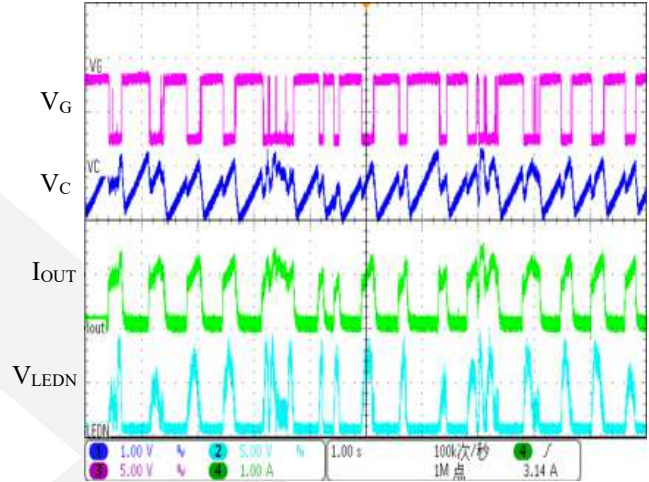

Current Ripple without DIO8221

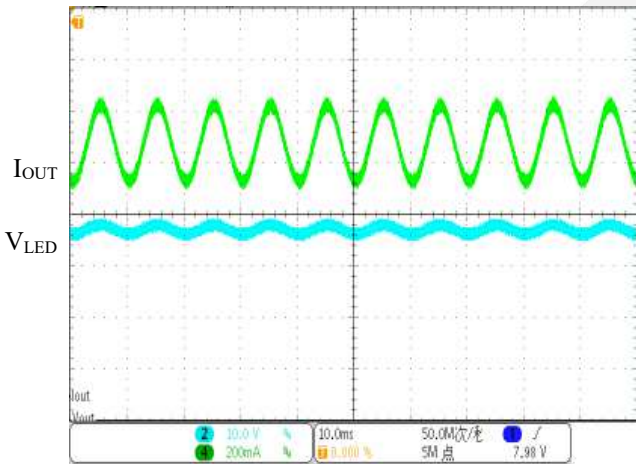

Current Ripple with DIO8221

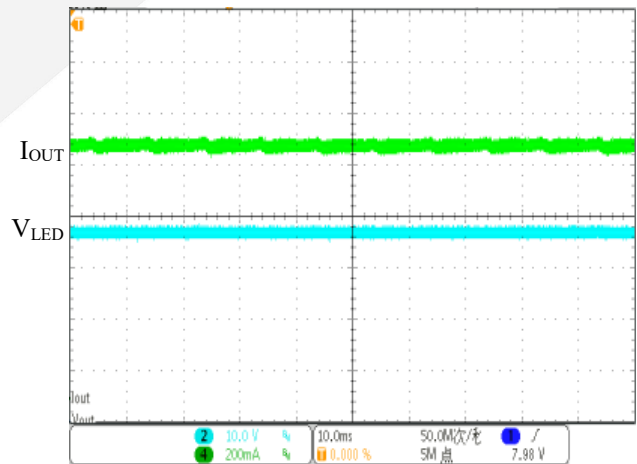

Power ON

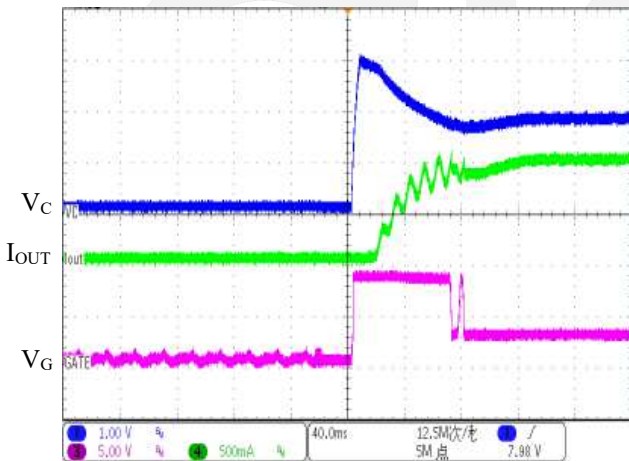

LED Hot plug test

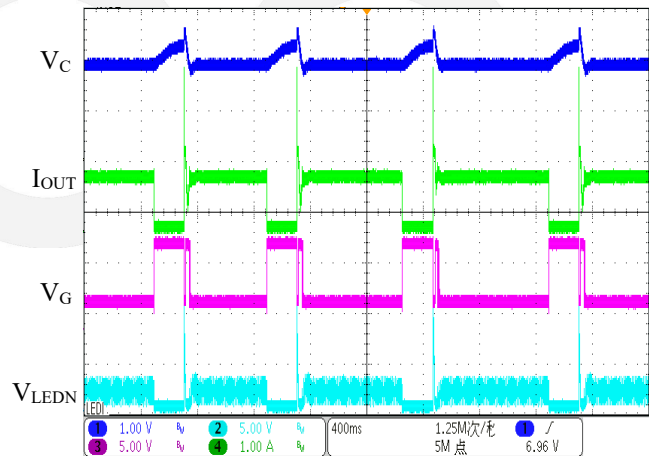

LED Open Protection test

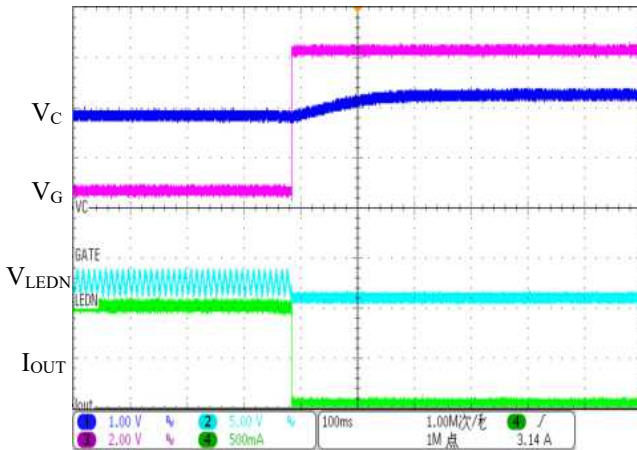

LED Short Protection test

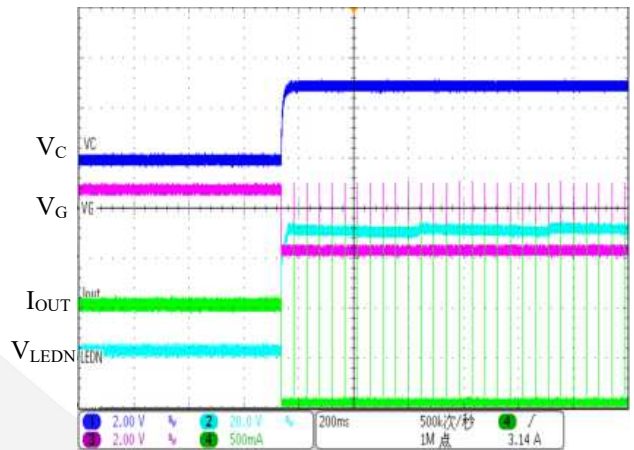

Dimming application test

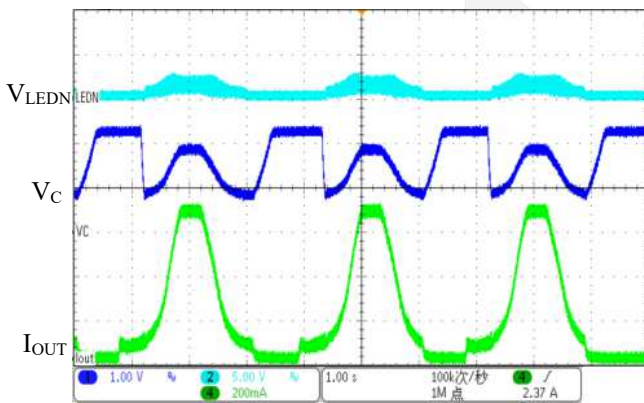

Functional Description

Theory of Operation:

The LED string and DIO8221 are both supplied by an AC/DC current source. The drain of external NMOSFET is connected to the cathode of LED string. A sensing resistor R_{CS} is connected between the source of NMOSFET and GND. The gate is connected to the VG of DIO8221.

DIO8221 drives NMOSFET to transfer the LED current ripple to voltage ripple on NMOSFET, and ensures the constant voltage across LED string and the current flow through LED string. The scalable adaptive function of DIO8221 can regulate the cathode voltage of LED string to minimum to improve the efficiency of the system.

Current Ripple Removing:

The capacitor C_C between V_C and GND is a integration capacitor. DIO8221 transform the voltage on C_C to a reference voltage. The current regulator regulates the voltage on R_{CS} equal to the reference voltage.

The relationship between the voltage on C_C and R_{CS} is shown as following:

$$V_{CS} = I_{LED} * R_{SENSE} = V_{VC} / 10$$

C_C should be large enough in order to remove the current ripple of the LED string. However, too large capacitor may slow down the dynamic response.

Adaptive Regulation:

DIO8221 control the voltage on C_C by monitoring the operation state of external NMOSFET. The efficiency of system is relatively low when NMOSFET is working in the saturation region. DIO8221 detects it and charges C_C to raise the V_{VC} and I_{LED} , then the output voltage of power supply is reduced, and the voltage drop on NMOSFET decreases.

Conversely, when NMOSFET is working in the linear region, LED current regulation loop is open. DIO8221 detects it and discharges C_C to reduce the V_{VC} and I_{LED} , then the output voltage of power supply is raised, and the LED current regulation loop is close.

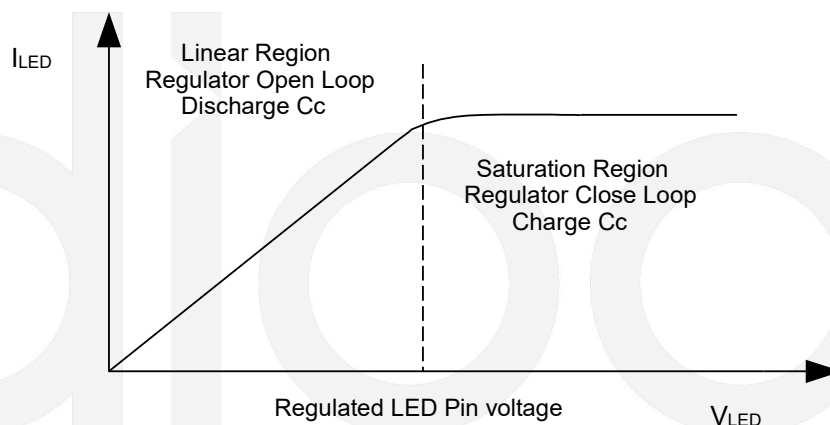

Drain Voltage of NMOSFET Limit:

The voltage ripple on the drain of NMOSFET maybe very large when the current ripple is removed, which would bring large power dissipation on chip. The resistor between the drain of NMOSFET and V_{LMT} pin can setup the limit value of drain voltage of NMOSFET.

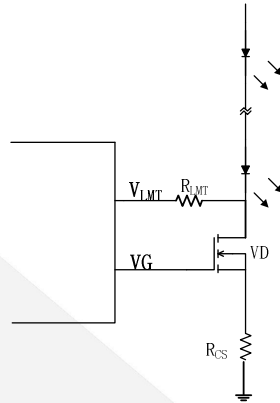

The limit threshold is calculated as below:

$$V_{LMT} = 2V + R_{LMT} * 20\mu A$$

LED Current Limit:

The voltage of VS pin is limited to 0.2V internally. So the current limitation is 0.2V/R_{CS}. Current limit can protect the chip when LED is short connected or HOT-PLUG. The function of current limit is higher priority than drain voltage limit. It means that the voltage on drain of NMOSFET is not limited when LED current exceed current limit threshold.

LED Short Protection:

DIO8221 detect short by R_{LMT}. When the drain voltage of NMOSFET exceeds the short protection threshold and the state holds for more than 70μs, DIO8221 considers the LED string is short connected, and shut down the external MOSFET. The short state is reset after 40ms.

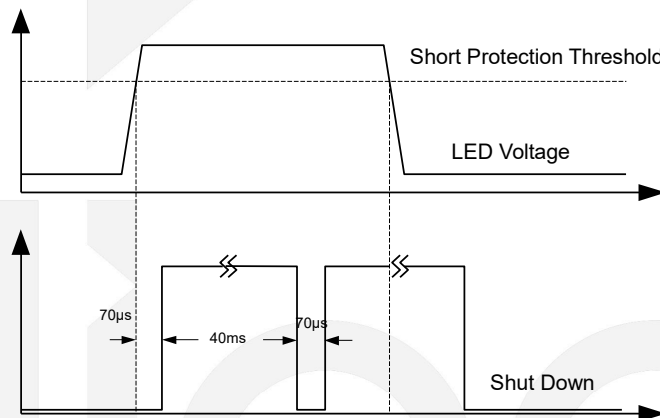

The short protection threshold is calculated as below:

$$V_{THSCP} = 2V + R_{LMT} * 40\mu A$$

Over Thermal Protection:

DIO8221 monitors operation temperature. When the temperature is higher than 135°C, the NMOSFET is shut down until the temperature decrease to 110°C.

PCB Design Guideline:

1. The bypass capacitor of VIN should be placed as close as possible to the VIN pin and GND pin of IC.
2. DIO8221 should be placed far away from the power devices such as MOSFET and SBD.
3. The area of LED current loop should be as small as possible.

Application note

DIO8221 design guide:

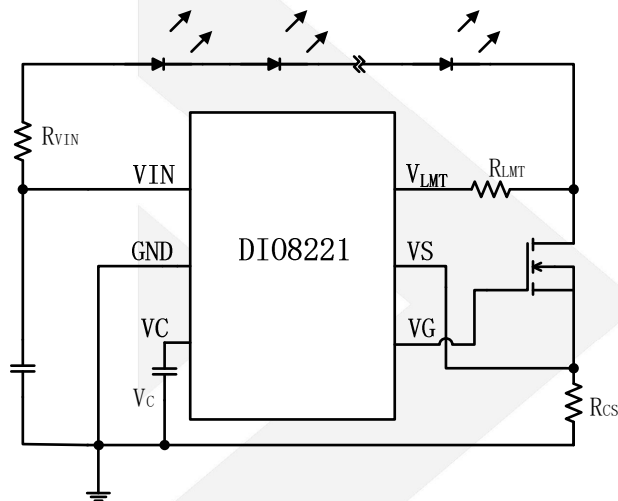

1. Because of the 37V zener integrated and the 16V VIN start threshold, the value of R_{VIN} may satisfy the following conditions:

$$R_{VIN} < \frac{V_F - 16V}{0.5mA}$$

V_F : the voltage of LED.

2. The maximum voltage of VS pin is 2V in order to limit the maximum output current especially in the short circuit condition. The value of R_{CS} can be calculated as below:

$$R_{CS} < \frac{0.2V}{I_{LED}}$$

I_{LED} : the output current of the pre-driver.

Recommend the DIO8221 VS voltage range of 0.08~0.12V typical. In order to ensure nothing will be damaged, the value of VS must be less than 0.15V. Low VS voltage will increase short circuit power consumption. High VS voltage will reduce the system efficiency.

3. When the voltage of LED- reaches V_{SCP} which is set by the R_{LMT} , DIO8221 turns off the MOSFET. In order to ensure nothing will be damaged in the short circuit condition, the value of R_{LMT} must satisfy the following conditions:

$$V_{OVP} - V_F < V_{SCP} < V_F$$

$$V_{SCP} < V_{INSTART} = R_{VIN} * 0.5mA + 16V$$

$$V_{SCP} = 2V + 40\mu A * R_{LMT}$$

V_{OVP} : the output voltage when the pre-driver is open.

V_{SCP} : the threshold of DIO8221 short circuit protection.

$V_{INSTART}$: the output voltage of the pre-driver when the V_{IN} of DIO8221 is 16V.

4. The value of the capacitor between VC and GND can determine the final amplitude of the current ripple. It should be large enough in order to remove the current ripple of the LED string. However, too large capacitor may slow down the dynamic response. In normal condition, 1 μ F or 2.2 μ F is relatively reasonable.
5. To ensure DIO8221 work properly, the R_{DSON} of MOSFET must be less than 3 R_s . The MOSFET will endure a large power shorting the output on the moment, so the appropriate package and R_{DSON} of the MOSFET is necessary.
6. When short the LED, there is an overshoot on the drain of the MOSFET. The breakdown voltage of the MOSFET must be higher than V_{OVP} . A diode connected to LED+&LED- can reduce the overshoot when short.





DIO8221

Controller for Adaptive 100/120Hz, Current Ripple Removing Circuit

CONTACT US

Dioo is a professional design and sales corporation for high-quality and performance analog semiconductors. The company focuses on industry markets, such as, cell phone, handheld products, laptop, and medical equipment and so on. Dioo's product families include analog signal processing and amplifying, LED drivers and charger IC. Go to <http://www.dioo.com> for a complete list of Dioo product families.

For additional product information, or full datasheet, please contact with our Sales Department or Representatives.

dioo

X-ON Electronics

Largest Supplier of Electrical and Electronic Components

Click to view similar products for [LED Lighting Drivers](#) category:

Click to view products by [Dioo](#) manufacturer:

Other Similar products are found below :

[LV5235V-MPB-H](#) [MB39C602PNF-G-JNEFE1](#) [MIC2871YMK-T5](#) [AL1676-10BS7-13](#) [AL1676-20AS7-13](#) [AP5726WUG-7](#) [ICL8201](#)
[IS31BL3228B-UTLS2-TR](#) [IS31BL3506B-TTLS2-TR](#) [AL3157F-7](#) [AP5725FDCG-7](#) [LV52204MTTBG](#) [AP5725WUG-7](#) [STP4CMPQTR](#)
[NCL30086BDR2G](#) [CAT4004BHU2-GT3](#) [LV52207AXA-VH](#) [AP1694AS-13](#) [TLE4242EJ](#) [KTD2027EWE-TR](#) [AS3688](#) [IS31LT3172-GRLS4-TR](#)
[TLD2311EL](#) [KTD2694EDQ-TR](#) [KTZ8864EJAA-TR](#) [IS32LT3174-GRLA3-TR](#) [MP2488DN-LF-Z](#) [NLM0010XTSA1](#) [AL1676-20BS7-13](#)
[ZXLD1370QESTTC](#) [MPQ7220GF-AEC1-P](#) [MPQ4425BGJ-AEC1-P](#) [MPQ7220GF-AEC1-Z](#) [MPQ4425BGJ-AEC1-Z](#) [IS31FL3737B-QFLS4-TR](#)
[IS31FL3239-QFLS4-TR](#) [KTD2058EUAC-TR](#) [KTD2037EWE-TR](#) [DIO5662ST6](#) [KTD2026BEWE-TR](#) [MAX20052CATC/V+](#)
[MAX25606AUP/V+](#) [BD6586MUV-E2](#) [BD9206EFV-E2](#) [LYT4227E](#) [LYT6079C-TL](#) [MP3394SGF-P](#) [MP4689AGN-P](#) [MPQ4425AGQB-AEC1-Z](#) [KTD2060EUAC-TR](#)