

24-bit 192 kHz Stereo ADC

DESCRIPTION

The WM8782 is a high performance, low cost stereo audio ADC designed for recordable media applications.

The device offers stereo line level inputs along with two control input pins (FORMAT, IWL) to allow operation of the audio interface in three industry standard modes. An internal op-amp is integrated on the front end of the chip to accommodate analogue input signals greater than $1V_{rms}$. The device also has a high pass filter to remove residual DC offsets.

WM8782 offers Master or Slave mode clocking schemes. A control input pin M/S is used to allow Slave mode operation or Master mode operation. A stereo 24-bit multi-bit sigma-delta ADC is used with 128x, 64x or 32x oversampling, according to sample rate. Digital audio output word lengths from 16-24 bits and sampling rates from 8kHz to 192kHz are supported.

The device is a hardware controlled device and is supplied in a 20-lead SSOP package.

The device is available over a functional temperature range of -40°C to +85°C.

FEATURES

- SNR 100dB ('A' weighted @ 48kHz)
- THD -93dB (at -1dB)
- Sampling Frequency: 8 – 192kHz
- Master or Slave Clocking Mode
- System Clock (MCLK): 128fs, 192fs, 256fs, 384fs, 512fs, 768fs
 - Audio Data Interface Modes
- 16-24 bit I²S, 16-24 bit Left, 16-24 bit Right Justified
- Supply Voltages
 - Analogue: 2.7V to 5.5V
 - Digital core: 2.7V to 3.6V
- 20-lead SSOP or 20-lead TSSOP package
- Accelerated Lifetime Screened Devices available.

APPLICATIONS

- Recordable DVD Players
- Personal Video Recorders
- STB
- Studio Audio Processing Equipment
- Automotive

BLOCK DIAGRAM

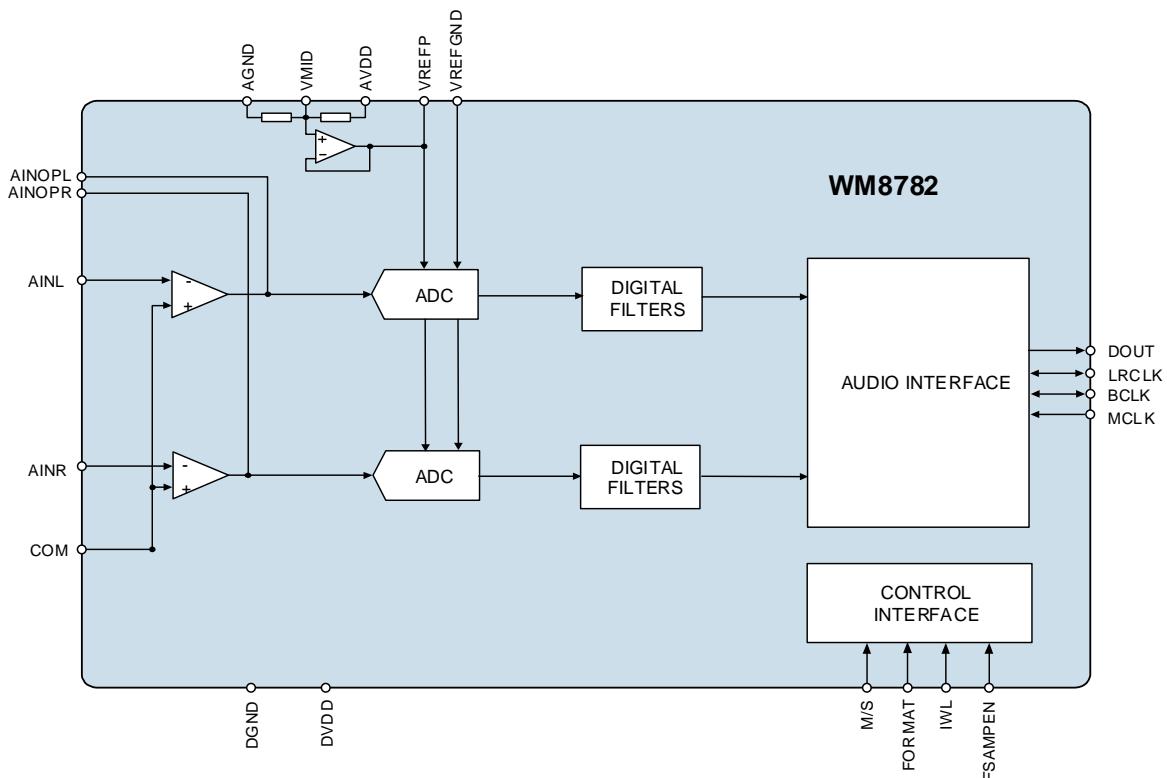
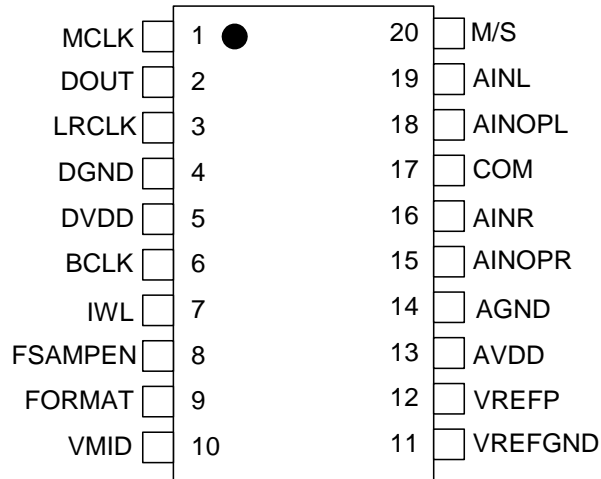

TABLE OF CONTENTS

DESCRIPTION	1
FEATURES	1
APPLICATIONS	1
BLOCK DIAGRAM	1
TABLE OF CONTENTS	2
PIN CONFIGURATION	3
ORDERING INFORMATION	3
PIN DESCRIPTION	4
ABSOLUTE MAXIMUM RATINGS	5
THERMAL PERFORMANCE	5
RECOMMENDED OPERATING CONDITIONS	6
ELECTRICAL CHARACTERISTICS	6
TERMINOLOGY	7
SIGNAL TIMING REQUIRMENTS	8
SYSTEM CLOCK TIMING.....	8
AUDIO INTERFACE TIMING – MASTER MODE	8
AUDIO INTERFACE TIMING – SLAVE MODE	9
SLAVE MODE MCLK / BCLK TIMING	10
DEVICE DESCRIPTION	11
INTRODUCTION	11
ADC	11
ADC DIGITAL FILTER	12
DIGITAL AUDIO INTERFACE.....	12
POWER-ON RESET	16
DIGITAL FILTER CHARACTERISTICS	18
ADC FILTER RESPONSE.....	18
ADC HIGH-PASS FILTER.....	19
APPLICATIONS INFORMATION	20
RECOMMENDED EXTERNAL COMPONENTS.....	20
RECOMMENDED EXTERNAL COMPONENTS VALUES.....	20
PACKAGE DIMENSIONS	21
IMPORTANT NOTICE	22
REVISION HISTORY	23

PIN CONFIGURATION

ORDERING INFORMATION

DEVICE	TEMPERATURE RANGE	PACKAGE	PEAK SOLDERING TEMPERATURE
WM8782SEDS/V	-40°C to +85°C	20-lead SSOP (Pb-free)	260°C
WM8782SEDS/RV	-40°C to +85°C	20-lead SSOP (Pb-free, tape and reel)	260°C

Note:

Reel quantity = 2,000

PIN DESCRIPTION

PIN NO.	NAME	TYPE	DESCRIPTION
1	MCLK	Digital Input	Master Clock
2	DOUT	Digital Output	ADC Digital Audio Data
3	LRCLK	Digital Input / Output	Audio Interface Left / Right Clock
4	DGND	Supply	Digital Negative Supply
5	DVDD	Supply	Digital Positive Supply
6	BCLK	Digital Input / Output	Audio Interface Bit Clock
7	IWL	Digital Tristate Input	Word Length 0 = 16 bit 1 = 20 bit Z = 24 bit
8	FSAMPEN	Digital Tristate Input	Fast Sampling Rate Enable 0 = 48kHz 1 = 96kHz Z = 192kHz
9	FORMAT	Digital Tristate Input	Audio Mode Select 0 = RJ 1 = LJ Z = I2S
10	VMID	Analogue Output	Mid rail Voltage Decoupling Capacitor
11	VREFGND	Supply	Negative Supply and Substrate Connection
12	VREFP	Analogue Output	Positive Reference Voltage Decoupling Pin; 10uF external decoupling
13	AVDD	Supply	Analogue Positive Supply
14	AGND	Supply	Analogue Negative Supply and Substrate Connection
15	AINOPR	Analogue Output	Right Channel Internal Op-Amp Output
16	AINR	Analogue Input	Right Channel Input
17	COM	Analogue Input	Common mode high impedance input should be set to midrail.
18	AINOPL	Analogue Output	Left Channel Internal Op-Amp Output
19	AINL	Analogue Input	Left Channel Input
20	M/S	Digital Input	Interface Mode Select 0 = Slave mode (128fs, 192fs, 256fs, 384fs, 512fs, 768fs) 1 = Master mode (256fs, 128fs) (fs=word clock frequency)

ABSOLUTE MAXIMUM RATINGS

Absolute Maximum Ratings are stress ratings only. Permanent damage to the device may be caused by continuously operating at or beyond these limits. Device functional operating limits and guaranteed performance specifications are given under Electrical Characteristics at the test conditions specified.



ESD Sensitive Device. This device is manufactured on a CMOS process. It is therefore generically susceptible to damage from excessive static voltages. Proper ESD precautions must be taken during handling and storage of this device.

CONDITION	MIN	MAX
Digital supply voltage	-0.3V	+4.5V
Analogue supply voltage	-0.3V	+7V
Voltage range digital inputs	DGND -0.3V	DVDD + 0.3V
Voltage range analogue inputs	AGND -0.3V	AVDD +0.3V
Ambient temperature (supplies applied)	-55°C	+125°C
Storage temperature	-65°C	+150°C
Pb free package body temperature (reflow 10 seconds)		+260°C
Package body temperature (soldering 2 minutes)		+183°C

Notes:

- Analogue and digital grounds must always be within 0.3V of each other.

THERMAL PERFORMANCE

PARAMETER	SYMBOL	TEST CONDITIONS	MIN	TYP	MAX	UNIT
Thermal resistance – junction to ambient	$R_{\theta JA}$			81 See note 1		°C/W

Notes:

- Figure given for package mounted on 4-layer FR4 according to JESD51-7. (No forced air flow is assumed).
- Thermal performance figures are estimated.

RECOMMENDED OPERATING CONDITIONS

PARAMETER	SYMBOL	TEST CONDITIONS	MIN	TYP	MAX	UNIT
Digital supply range	DVDD	WM8782SEDS, WM8782SEDS/R	2.7		3.6	V
Analogue supply range	AVDD	WM8782SEDS, WM8782SEDS/R	2.7		5.5	V
Ground	DGND,AGND			0		V
Operating temperature range	T _A	WM8782SEDS, WM8782SEDS/R	-40		+85	°C

Notes:

- Digital supply DVDD must never be more than 0.3V greater than AVDD.

ELECTRICAL CHARACTERISTICS
Test Conditions

DVDD = 3.3V, AVDD = 5.0V, T_A = +25°C, 1kHz signal, A-weighted, fs = 48kHz, MCLK = 256fs, 24-bit audio data, Slave Mode unless otherwise stated.

PARAMETER	SYMBOL	TEST CONDITIONS	MIN	TYP	MAX	UNIT
ADC Performance – WM8782SEDS, WM8782SEDS/R (+25°C)						
Full Scale Input Signal Level (for ADC 0dB Input)				1.0		V _{rms}
Input resistance, using recommended external resistor network on p22.				10		kΩ
Input capacitance				20		pF
Signal to Noise Ratio (see Terminology note 1,2,4)	SNR	weighted, @ fs = 48kHz	93	100		dB
		Unweighted, @ fs = 48kHz		98		dB
		weighted, @ fs = 48kHz, AVDD = 3.3V		98		dB
Signal to Noise Ratio (see Terminology note 1,2,4)	SNR	weighted, @ fs = 96kHz		98		dB
		Unweighted, @ fs = 96kHz		98		dB
		weighted, @ fs = 96kHz AVDD = 3.3V		98		dB
Total Harmonic Distortion	THD	1kHz, -1dB Full Scale @ fs = 48kHz		-93		dB
		1kHz, -1dB Full Scale @ fs = 96kHz		-93		dB
		1kHz, -1dB Full Scale @ fs = 192kHz		-92		dB
Dynamic Range	DNR	-60dBFS	93	100		dB
Channel Separation (see Terminology note 4)		1kHz Input		90		dB
Channel Level Matching		1kHz signal		0.1		dB
Channel Phase Deviation		1kHz signal		0.0001		Degree
Power Supply Rejection Ratio	PSRR	1kHz 100mVpp, applied to AVDD, DVDD		50		dB

Test Conditions

DVDD = 3.3V, AVDD = 5.0V, T_A = +25°C, 1kHz signal, A-weighted, f_s = 48kHz, MCLK = 256fs, 24-bit audio data, Slave Mode unless otherwise stated.

PARAMETER	SYMBOL	TEST CONDITIONS	MIN	TYP	MAX	UNIT
Digital Logic Levels (TTL Levels)						
Input LOW level	V _{IL}				0.8	V
Input HIGH level	V _{IH}		2.0			V
Input leakage current – digital pad			-1	±0.2	+1	µA
Input leakage current – digital tristate input (Note 3)				85		µA
Input capacitance				5		pF
Output LOW	V _{OL}	I _{OL} =1mA			0.1 x DVDD	V
Output HIGH	V _{OH}	I _{OH} =-1mA	0.9 x DVDD			V
Analogue Reference Levels						
Midrail Reference Voltage	VMID	AVDD to VMID and VMID to VREFN	-4%	AVDD/2	+4%	V
Potential Divider Resistance	R _{VMID}			70		kΩ
Buffered Reference Voltage	VREFP		-4%	AVDD/2	+4%	V
VREF source current	I _{VREF}				5	mA
VREF sink current	I _{VREF}				5	mA
Supply Current						
Analogue supply current		AVDD = 5V		26		mA
Digital supply current		DVDD = 3.3V		5		mA
Power Down				0.5		mA

Notes:

1. All performance measurements are done with a 20kHz low pass filter, and where noted an A-weight filter. Failure to use such a filter will result in higher THD+N and lower SNR and Dynamic Range readings than are found in the Electrical Characteristics. The low pass filter removes out of band noise; although this is not audible, it may affect dynamic specification values.
2. VMID is decoupled with 10µF and 0.1µF capacitors close to the device package. Smaller capacitors may reduce performance.
3. This high leakage current is due to the topology of the instate pads. The pad input is connected to the midpoint of an internal resistor string to pull input to vmid if undriven.

TERMINOLOGY

1. Signal-to-noise ratio (dB) – Ratio of output level with 1kHz full scale input, to the output level with all zeros into the digital input, over a 20Hz to 20kHz bandwidth. (No Auto-zero or Automute function is employed in achieving these results).
2. Dynamic range (dB) – DR is a measure of the difference between the highest and lowest portions of a signal. Normally a THD+N measurement at 60dB below full scale. The measured signal is then corrected by adding the 60dB to it. (e.g. THD+N @ -60dB= -32dB, DR= 92dB).
3. THD+N (dB) – THD+N is a ratio, of the rms values, of (Noise + Distortion)/Signal.
4. Channel Separation (dB) – Also known as Cross-Talk. This is a measure of the amount one channel is isolated from the other. Normally measured by sending a full scale signal down one channel and measuring the other.

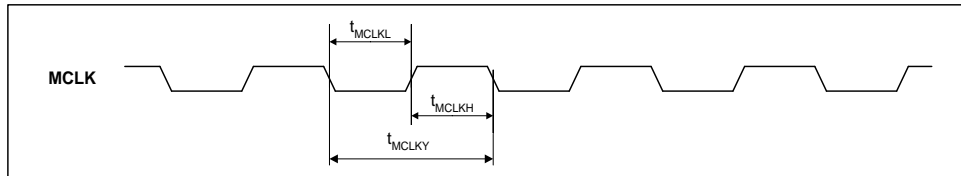
SIGNAL TIMING REQUIREMENTS
SYSTEM CLOCK TIMING

Figure 1 System Clock Timing Requirements
Test Conditions

 DVDD = 3.3V, DGND = 0V, $T_A = +25^\circ\text{C}$, $f_s = 48\text{kHz}$, Slave Mode, MCLK = 256fs, 24-bit data, unless otherwise stated.

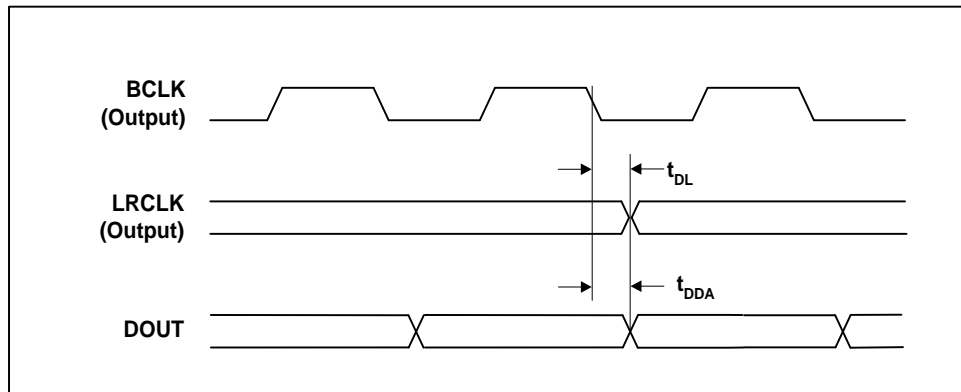
PARAMETER	SYMBOL	MIN	TYP	MAX	UNIT
System Clock Timing Information					
MCLK System clock pulse width high	T_{MCLKL}	11			ns
MCLK System clock pulse width low	T_{MCLKH}	11			ns
MCLK System clock cycle time	T_{MCLKY}	28			ns
MCLK duty cycle	T_{MCLKDS}	40:60		60:40	

Table 1 Master Clock Timing Requirements
AUDIO INTERFACE TIMING – MASTER MODE

Figure 2 Digital Audio Data Timing – Master Mode (see Control Interface)
Test Conditions

 DVDD = 3.3V, DGND = 0V, $T_A = +25^\circ\text{C}$, Master Mode, $f_s = 48\text{kHz}$, MCLK = 256fs, 24-bit data, unless otherwise stated.

PARAMETER	SYMBOL	MIN	TYP	MAX	UNIT
Audio Data Input Timing Information					
LRCLK propagation delay from BCLK falling edge	t_{DL}	0		10	ns
DOUT propagation delay from BCLK falling edge	t_{DDA}	0		10	ns

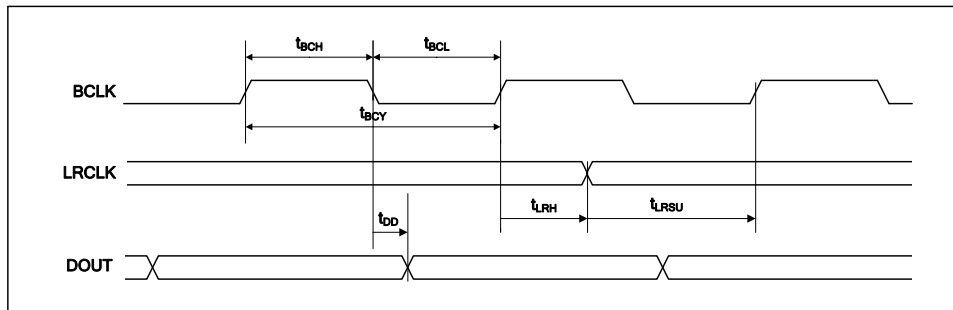
Table 2 Digital Audio Data Timing – Master Mode

AUDIO INTERFACE TIMING – SLAVE MODE

Figure 3 Digital Audio Data Timing – Slave Mode
Test Conditions

 DVDD = 3.3V, DGND = 0V, T_A = +25°C, Slave Mode, fs = 48kHz, MCLK = 256fs, 24-bit data, unless otherwise stated.

PARAMETER	SYMBOL	MIN	TYP	MAX	UNIT
Audio Data Input Timing Information					
BCLK cycle time	t _{BCY}	50			ns
BCLK pulse width high	t _{BCH}	20			ns
BCLK pulse width low	t _{BCL}	20			ns
LRCLK set-up time to BCLK rising edge	t _{LRSU}	10			ns
LRCLK hold time from BCLK rising edge	t _{LRH}	10			ns
DOUT propagation delay from BCLK falling edge	t _{DD}	0		10	ns

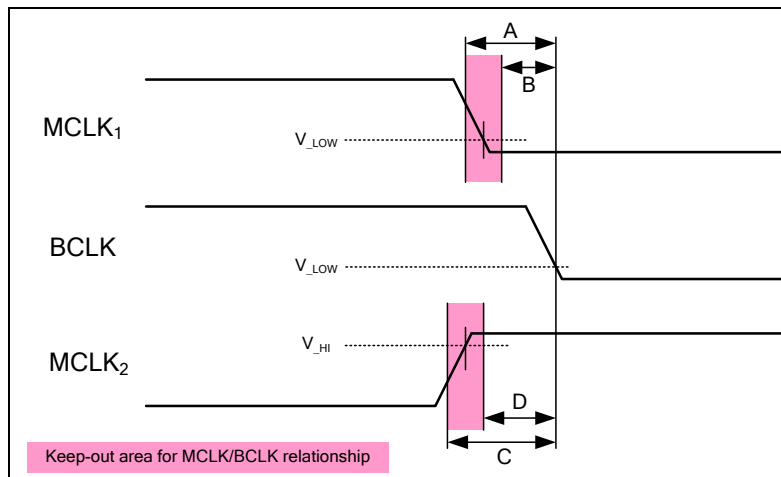
Table 3 Digital Audio Data Timing – Slave Mode
Note: LRCLK should be synchronous with MCLK.

SLAVE MODE MCLK / BCLK TIMING

Figure 4 MCLK / BCLK prohibited timing relationship in slave mode

TIMING	TIME (NS)	DESCRIPTION
A	9	MCLK falling edge to BCLK falling edge keep-out window
B	4	
C	9	MCLK rising edge to BCLK falling edge keep-out window
D	4	

Table 4 Prohibited area timings

In slave mode operation, there are two windows where the BCLK falling edge relative to the MCLK falling/rising edge is not allowed, as defined in Figure 4 and Table 4. Any device with clocks operating in this area may cause incorrect operation of the ADC, as detailed in WTR0444.

This specification is guaranteed by design rather than test, and the timings are related to the switching level of the MCLK and BCLK pads. Simulation has shown the switching level range for both the MCLK and BCLK pads across process, voltage and temperature to be as per the table below.

SWITCHING LEVEL	MIN (V)	MAX (V)
V _{LOW}	1.1	1.4
V _{HI}	1.3	1.6

Table 5 Simulated switching area range

If the above timing constraints cannot be met in slave mode, it is recommended that WM8782A silicon is used in place of WM8782.

DEVICE DESCRIPTION

INTRODUCTION

The WM8782 is a stereo 24-bit ADC designed for demanding recording applications such as DVD recorders, studio mixers, PVRs, and AV amplifiers. The WM8782 consists of stereo line level inputs, followed by a sigma-delta modulator and digital filtering.

The device offers stereo line level inputs along with two control input pins (FORMAT, IWL) to allow operation of the audio interface in three industry standard modes (left justified, right justified or I²S) . An internal op-amp is integrated on the front end of the chip to accommodate analogue input signals greater than 1V_{rms}. The device also has a high pass filter to remove residual DC offsets.

The WM8782 offers Master or Slave mode clocking schemes. A control input pin M/S is used to allow Slave mode or Master mode operation. The WM8782 supports master clock rates from 128fs to 768fs and digital audio output word lengths from 16-24 bits. Sampling rates from 8kHz to 192kHz are supported, delivering high SNR operating with 128x, 64x or 32x over-sampling, according to the sample rate.

The line inputs are biased internally through the operational amplifier to VMID.

ADC

The WM8782 uses a multi-bit over sampled sigma-delta ADC. A single channel of the ADC is illustrated in Figure 5.

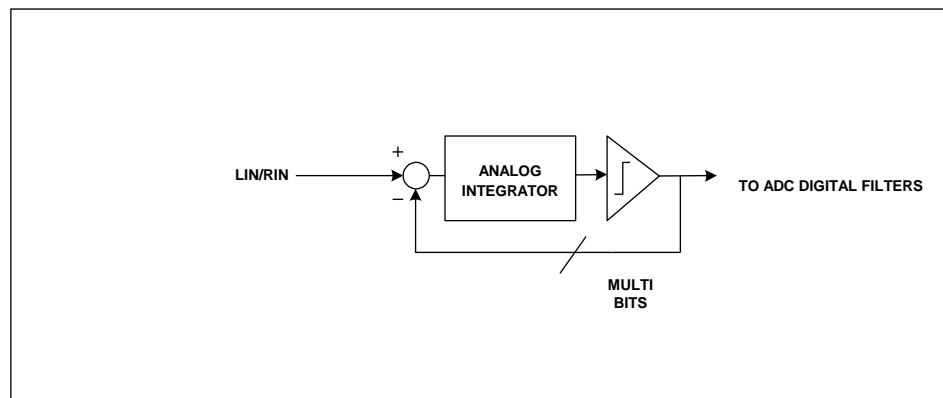

Figure 5 Multi-Bit Oversampling Sigma Delta ADC Schematic

The use of multi-bit feedback and high oversampling rates reduces the effects of jitter and high frequency noise.

The ADC Full Scale input is 1.0V rms at AVDD = 5.0 volts. Any input voltage greater than full scale will possibly overload the ADC and cause distortion. Note that the full scale input has a linear relationship with AVDD. The internal op-amp and appropriate resistors can be used to reduce signals greater than 1Vrms before they reach the ADC.

The ADC filters perform true 24 bit signal processing to convert the raw multi-bit oversampled data from the ADC to the correct sampling frequency to be output on the digital audio interface.

ADC OUTPUT PHASE

In the input to output data-path, the digital output data DOUT, is a phase inverted representation of the analogue input signal.

ADC DIGITAL FILTER

The ADC digital filters contain a digital high pass filter. The high-pass filter response detailed in Digital Filter Characteristics. The operation of the high pass filter removes residual DC offsets that are present on the audio signal.

DIGITAL AUDIO INTERFACE

The digital audio interface uses three pins:

- DOUT: ADC data output
- LRCLK: ADC data alignment clock
- BCLK: Bit clock, for synchronisation

The digital audio interface takes the data from the internal ADC digital filters and places it on DOUT and LRCLK. DOUT is the formatted digital audio data stream output from the ADC digital filters with left and right channels multiplexed together. LRCLK is an alignment clock that controls whether Left or Right channel data is present on the DOUT line. DOUT and LRCLK are synchronous with the BCLK signal with each data bit transition signified by a BCLK high to low transition. DOUT is always an output. BCLK and LRCLK maybe an inputs or outputs depending whether the device is in Master or Slave mode. (see Master and Slave Mode Operation, below).

Three different audio data formats are supported:

- Left justified
- Right justified
- I²S

MASTER AND SLAVE MODE OPERATION

The WM8782 can be configured as either a master or slave mode device. As a master device the WM8782 generates BCLK and LRCLK and thus controls sequencing of the data transfer on DOUT. In slave mode, the WM8782 responds with data to clocks it receives over the digital audio interface. The mode can be selected by setting the MS input pin (see Table 6 Master/Slave selection below). Master and slave modes are illustrated below.

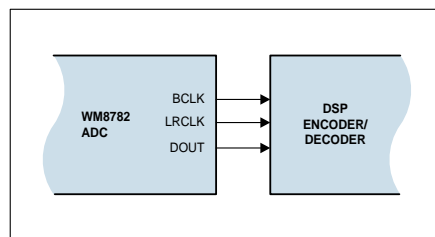

Figure 6 Master Mode

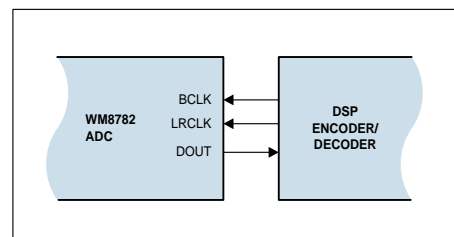

Figure 7 Slave Mode

PIN	DESCRIPTION
M/S	Master/Slave Selection 0 = Slave Mode 1 = Master Mode

Table 6 Master/Slave selection

AUDIO INTERFACE CONTROL

The Input Word Length and Audio Format mode can be selected by using IWL and FORMAT pins.

PIN	DESCRIPTION
IWL	Word Length 0 = 16 bit 1 = 20 bit Z = 24 bit
FORMAT	Audio Mode Select 0 = RJ 1 = LJ Z = I2S

Table 7 Audio Data Format Control

AUDIO DATA FORMATS

In Left Justified mode, the MSB is available on the first rising edge of BCLK following an LRCLK transition. The other bits up to the LSB are then transmitted in order. Depending on word length, BCLK frequency and sample rate, there may be unused BCLK cycles before each LRCLK transition.

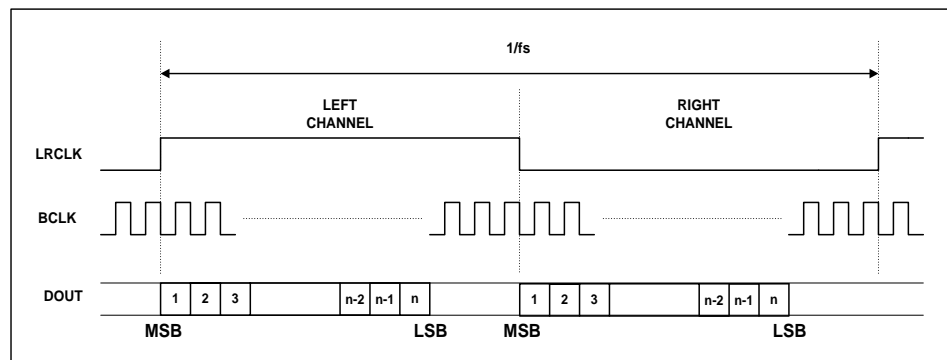
Figure 8 Left Justified Audio Interface (assuming n-bit word length)

In Right Justified mode, the LSB is available on the last rising edge of BCLK before an LRCLK transition. All other bits are transmitted before (MSB first). Depending on word length, BCLK frequency and sample rate, there may be unused BCLK cycles after each LRCLK transition.

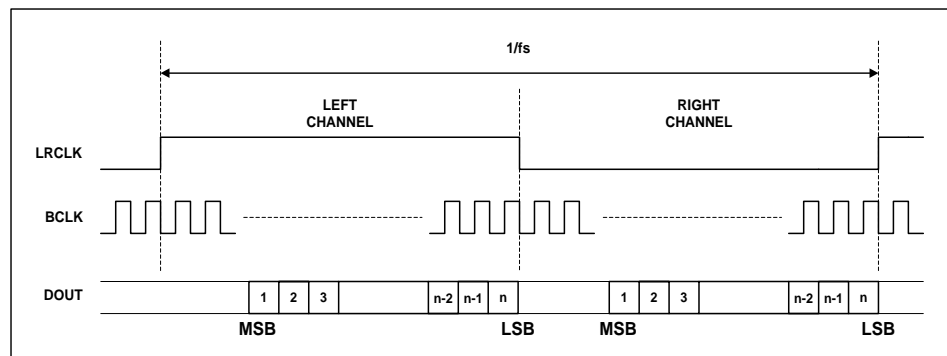
Figure 9 Right Justified Audio Interface (assuming n-bit word length)

In I²S mode, the MSB is available on the second rising edge of BCLK following an LRCLK transition. The other bits up to the LSB are then transmitted in order. Depending on word length, BCLK frequency and sample rate, there may be unused BCLK cycles between the LSB of one sample and the MSB of the next.

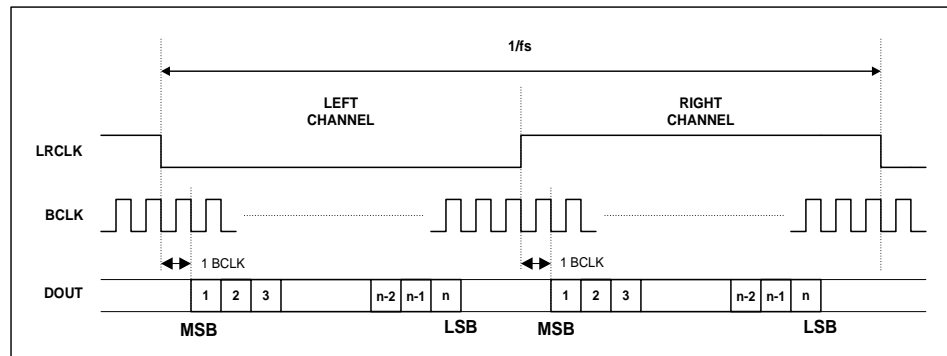

Figure 10 I2S Audio Interface (assuming n-bit word length)

MASTER CLOCK AND AUDIO SAMPLE RATES

In a typical digital audio system there is only one central clock source producing a reference clock to which all audio data processing is synchronised. This clock is often referred to as the audio system's Master Clock (MCLK). The external master system clock can be applied directly through the MCLK input pin. In a system where there are a number of possible sources for the reference clock it is recommended that the clock source with the lowest jitter be used to optimise the performance of the ADC.

The master clock is used to operate the digital filters and the noise shaping circuits. The WM8782 supports master clocks of 128fs, 192fs, 256fs, 384fs, 512fs and 768fs, where fs is the audio sampling frequency (LRCLK). In Slave Mode, the WM8782 automatically detects the audio sample rate. In Master Mode, LRCLK is generated for rate 256fs, unless the user changes this to 128fs using the FSAMPEN pin = z (see Table 9 below). BCLK is also generated in Master Mode. $BCLK = MCLK/4$ for 256fs, and $BCLK = MCLK/2$ for 128fs.

Table 8 shows the common MCLK frequencies for different sample rates.

SAMPLING RATE (LRCLK)	MASTER CLOCK FREQUENCY (MHZ)					
	128fs	192fs	256fs	384fs	512fs	768fs
8kHz	1.024	1.536	2.048	3.072	4.096	6.144
16kHz	2.048	3.072	4.096	6.144	8.192	12.288
32kHz	4.096	6.144	8.192	12.288	16.384	24.576
44.1kHz	5.6448	8.467	11.2896	16.9340	22.5792	33.8688
48kHz	6.144	9.216	12.288	18.432	24.576	36.864
96kHz	12.288	18.432	24.576	36.864	-	-
192kHz	24.576	36.864	-	-	-	-

Table 8 Master Clock Frequency Selection

In Slave mode, the WM8782 has a master detection circuit that automatically determines the relationship between the master clock frequency and the sampling rate (to within +/- 32 system clocks). If there is a greater than 32 clocks error the interface sets itself to the highest rate available (768fs). There must be a fixed number of MCLKS per LRCLK, although the WM8782 is tolerant of phase variations or jitter on these clocks.

FSAMPEN

The FSAMPEN pin controls the over sampling rate of the ADC. The WM8782 can operate at sample rates from 8kHz to 192kHz. The WM8782 uses a sigma-delta modulator that operates at an optimal frequency of 6.144MHz.

By default the WM8782 generates the ADC frequency at 128xOSR. At fs=48kHz, the ADC frequency is $128 \times OSR = 128 \times 48 \text{kHz} = 6.144 \text{MHz}$.

If $f_s=96\text{kHz}$, the FSAMPEN pin must be set to 1. In this case, the ADC frequency is $64 \times \text{OSR} = 64 \times 96\text{kHz} = 6.144\text{MHz}$.

If $f_s=192\text{kHz}$, the FSAMPEN pin must be set to z. In this case, the ADC frequency is $32 \times \text{OSR} = 32 \times 192\text{kHz} = 6.144\text{MHz}$.

It is recommended that the above settings are used for both master and slave mode.

PIN	DESCRIPTION
M/S	Master/Slave Selection 0 = Slave Mode (128fs, 192fs, 256fs, 384fs, 512fs, 768fs) 1 = Master Mode (256fs, 128fs when FSAMPEN=z)
FSAMPEN	Fast sampling rate enable 0 = 48ken (128x OSR) 1 = 96ken (64x OSR) z = 192ken (32x OSR)

Table 9 Master/Slave and Sampling Rate Enable Selection

POWER-DOWN CONTROL

The WM8782 can be powered down by stopping MCLK. Power down mode using MCLK is entered after $65536/f_s$ clocks. On power-up, the WM8782 applies the power-on reset sequence described below.

When MCLK is stopped DOUT is forced to zero.

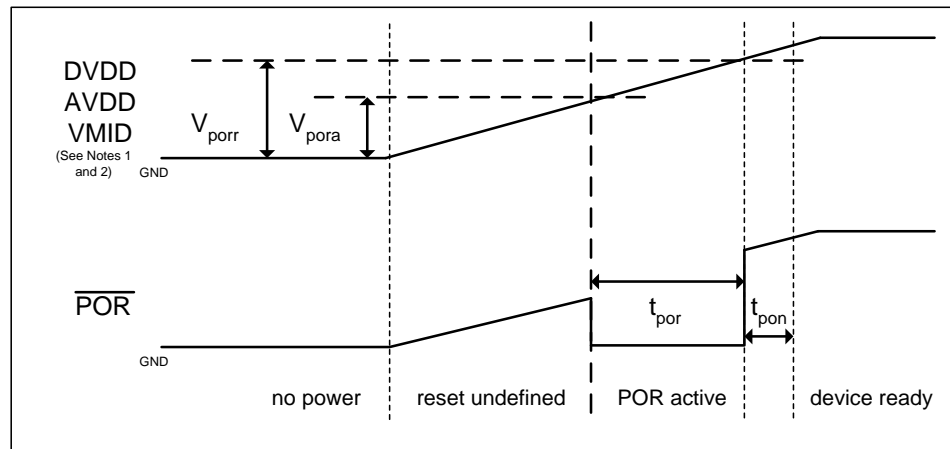
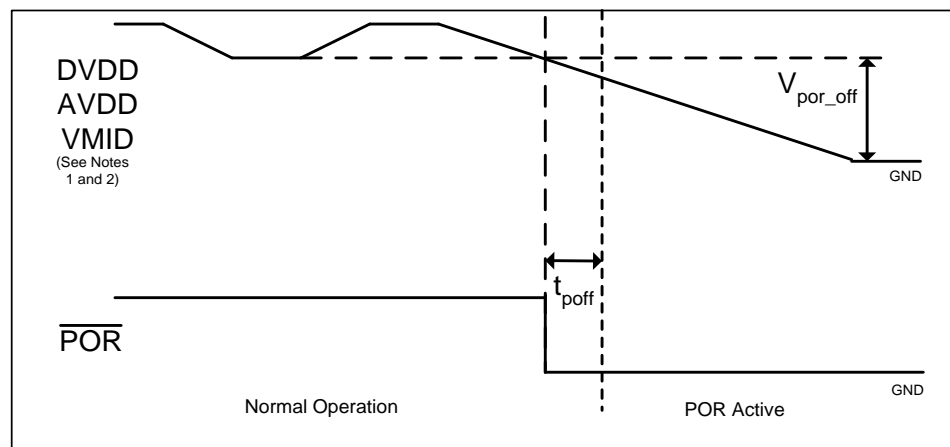
POWER-ON RESET

Figure 11 Power Supply Timing Requirements – Power-on

Figure 12 Power Supply Timing Requirements – Power-down

Test Conditions

 AVDD = 5V, DVDD = 3.3V, AGND = DGND = 0V, T_A = +25°C

PARAMETER	SYMBOL	TEST CONDITIONS	MIN	TYP	MAX	UNIT
Power Supply Input Timing Information						
DVDD level to activate POR – power on	V _{pora}	Measured from DGND		0.7		V
AVDD level to activate POR – power on	V _{pora}	Measured from AGND		0.7		V
VMID level to activate POR – power on	V _{pora}	Measured from AGND		0.7		V
DVDD level to release POR – power on (see notes 1 and 2)	V _{porr}	Measured from DGND		DVDD Min		V
AVDD level to release POR – power on (see notes 1 and 2)	V _{porr}	Measured from AGND		AVDD Min		V
VMID level to release POR – power on (see notes 1 and 2)	V _{porr}	Measured from AGND		1		V
POR active period (see notes 1 and 2)	t _{por}	Measured from POR active to POR release	30 (note 6)	Defined by DVDD/AVDD/ VMID Rise Time		μs
DVDD level to activate POR – power off (see note 5)	V _{por_off}	Measured from DGND		0.8		V
AVDD level to activate POR – power off (see note 5)	V _{por_off}	Measured from AGND		0.8		V
VMID level to activate POR – power off (see note 5)	V _{por_off}	Measured from AGND		0.7		V
Power on – POR propagation delay through device	t _{pon}	Measured from rising EDGE of POR		30		μs
Power down – POR propagation delay through device	t _{poff}	Measured from falling EDGE of POR		30		μs

Notes:

- POR is activated when DVDD or AVDD or VMID reach their stated V_{pora} level (Figure 11)
- POR is only released when DVDD and AVDD and VMID have all reached their stated V_{porr} levels (Figure 11).
- The rate of rise of VMID depends on the rate of rise of AVDD, the internal 50kΩ resistance and the external decoupling capacitor. Typical tolerance of 50K resistor can be taken as +/-20%.
- If AVDD, DVDD or VMID suffer a brown-out (i.e. drop below the minimum recommended operating level but do not go below V_{por_off}), then the chip will not reset and will resume normal operation when the voltage is back to the recommended level again.
- The chip will enter reset at power down when AVDD or DVDD or VMID falls below V_{por_off}. This may be important if the supply is turned on and off frequently by a power management system.
- The minimum t_{por} period is maintained even if DVDD, AVDD and VMID have zero rise time. This specification is guaranteed by design rather than test.

DIGITAL FILTER CHARACTERISTICS

The WM8782 digital filter characteristics scale with sample rate.

PARAMETER	TEST CONDITIONS	MIN	TYP	MAX	UNIT
ADC Sample Rate (Single Rate – 48Hz typically)					
Passband	+/- 0.01dB	0		0.4535fs	
	-6dB		0.4892fs		
Passband Ripple				+/- 0.01	dB
Stopband		0.5465fs			
Stopband Attenuation	f > 0.5465fs	-65			dB
Group Delay			22		fs
ADC Sample Rate (Dual Rate – 96kHz typically)					
Passband	+/- 0.01dB	0		0.4535fs	
	-6dB		0.4892fs		
Passband Ripple				+/- 0.01	dB
Stopband		0.5465fs			
Stopband Attenuation	f > 0.5465fs	-65			dB
Group Delay			22		fs

Table 10 Digital Filter Characteristics

ADC FILTER RESPONSE

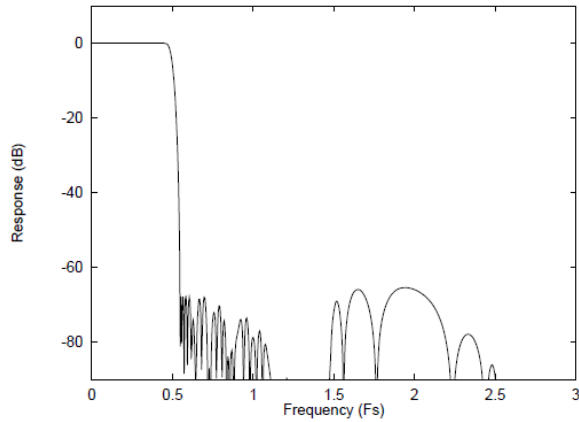

Figure 13 Digital Filter Frequency Response

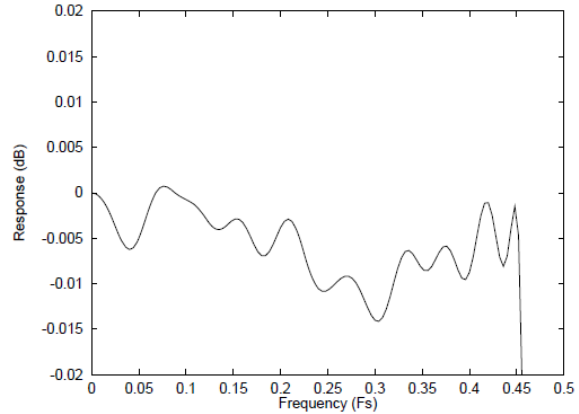

Figure 14 ADC Digital Filter Ripple

ADC HIGH-PASS FILTER

The WM8782 has a digital high-pass filter to remove DC offsets. The filter response is characterised by the following polynomial.

$$H(z) = \frac{1 - z^{-1}}{1 - 0.9995z^{-1}}$$

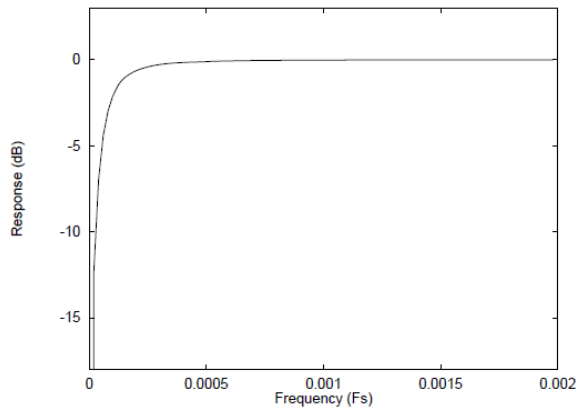
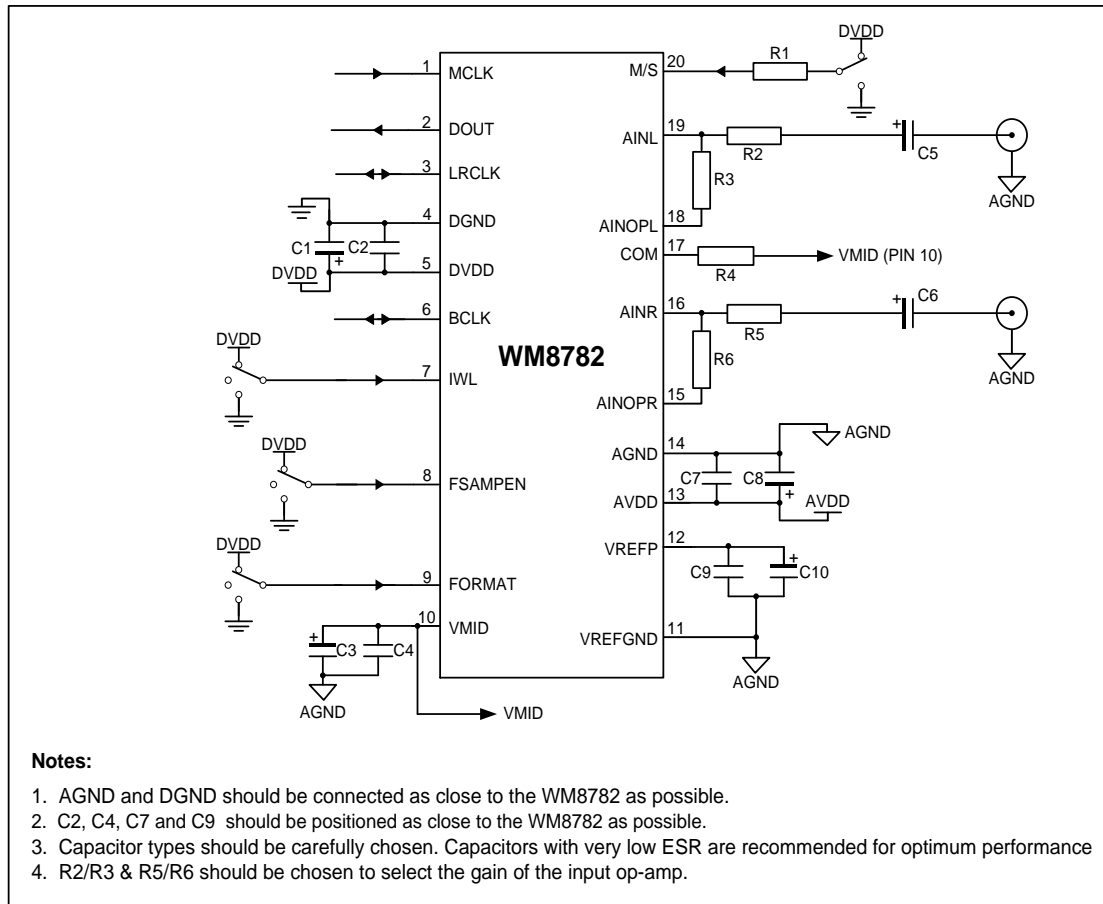

Figure 15 ADC Highpass Filter Response

APPLICATIONS INFORMATION
RECOMMENDED EXTERNAL COMPONENTS

Figure 16 External Components Diagram
RECOMMENDED EXTERNAL COMPONENTS VALUES

COMPONENT REFERENCE	SUGGESTED VALUE	DESCRIPTION
C1 and C8	10 μ F	De-coupling for DVDD and AVDD
C2 and C7	0.1 μ F	De-coupling for DVDD and AVDD
C5 and C6	10 μ F	Analogue input AC coupling caps
R1	10k Ω	Current limiting resistors
R2 and R5	10k Ω	Internal op-amp input resistor
R3 and R6	5k Ω	Internal op-amp feedback resistor
R4	3.3k Ω	Common mode resistor
C4	0.1 μ F	Reference de-coupling capacitors for VMID pin
C3	10 μ F	
C9	0.1 μ F	Reference de-coupling capacitors for VREFP pin
C10	10 μ F	

Table 11 External Components Description

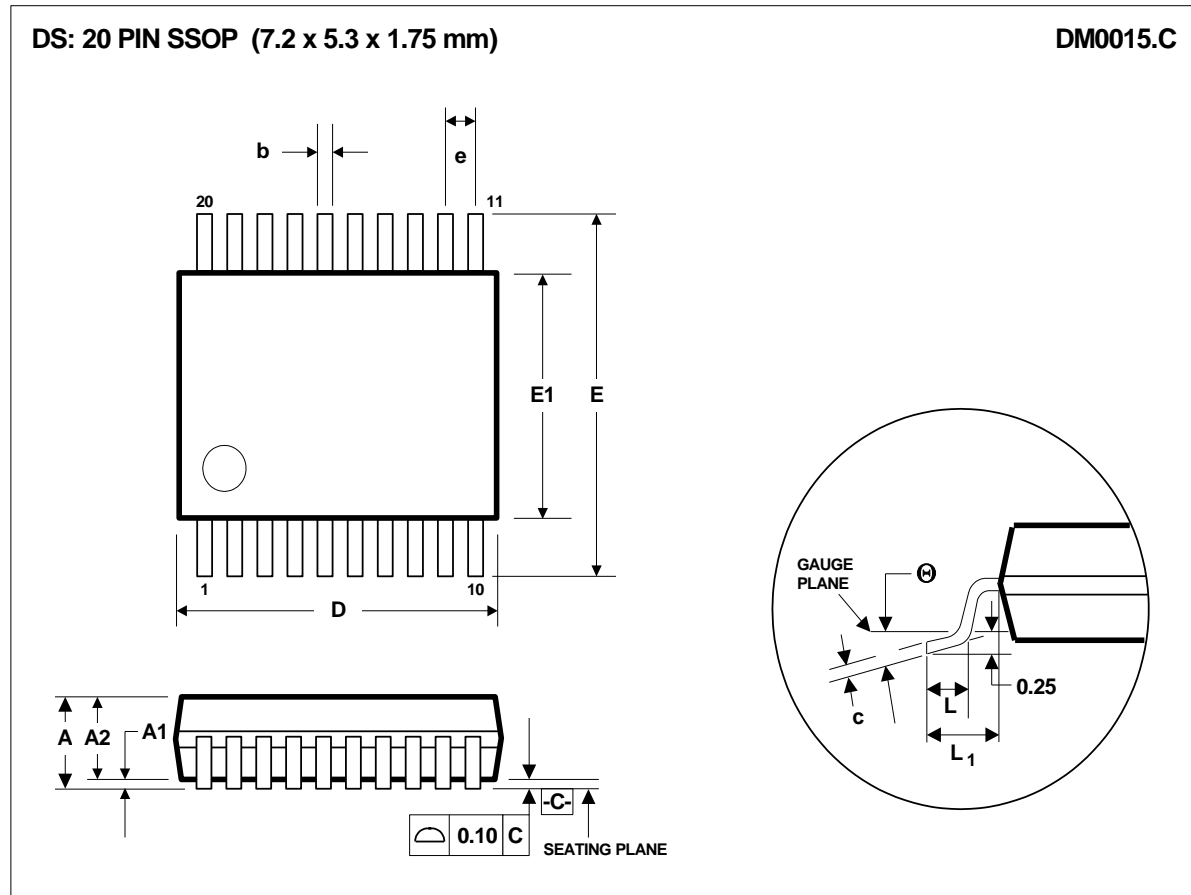
The above Table 11 shows resistor values which will give a gain of 0.5. This assumes an input signal of 2Vrms to C4 and C5.

PACKAGE DIMENSIONS

Symbols	Dimensions (mm)		
	MIN	NOM	MAX
A	-----	-----	2.0
A₁	0.05	-----	-----
A₂	1.65	1.75	1.85
b	0.22	0.30	0.38
c	0.09	-----	0.25
D	6.90	7.20	7.50
e	0.65 BSC		
E	7.40	7.80	8.20
E₁	5.00	5.30	5.60
L	0.55	0.75	0.95
L₁	1.25 REF		
θ	0°	4°	8°
REF:	JEDEC.95, MO-150		

NOTES:

- A. ALL LINEAR DIMENSIONS ARE IN MILLIMETERS.
- B. THIS DRAWING IS SUBJECT TO CHANGE WITHOUT NOTICE.
- C. BODY DIMENSIONS DO NOT INCLUDE MOLD FLASH OR PROTRUSION, NOT TO EXCEED 0.20MM.
- D. MEETS JEDEC.95 MO-150, VARIATION = AE. REFER TO THIS SPECIFICATION FOR FURTHER DETAILS.

IMPORTANT NOTICE

Contacting Cirrus Logic Support

For all product questions and inquiries, contact a Cirrus Logic Sales Representative.
To find one nearest you, go to www.cirrus.com.

For the purposes of our terms and conditions of sale, "Preliminary" or "Advanced" datasheets are non-final datasheets that include but are not limited to datasheets marked as "Target", "Advance", "Product Preview", "Preliminary Technical Data" and/or "Pre-production." Products provided with any such datasheet are therefore subject to relevant terms and conditions associated with "Preliminary" or "Advanced" designations. The products and services of Cirrus Logic International (UK) Limited; Cirrus Logic, Inc.; and other companies in the Cirrus Logic group (collectively either "Cirrus Logic" or "Cirrus") are sold subject to Cirrus Logic's terms and conditions of sale supplied at the time of order acknowledgment, including those pertaining to warranty, indemnification, and limitation of liability. Software is provided pursuant to applicable license terms. Cirrus Logic reserves the right to make changes to its products and specifications or to discontinue any product or service. Customers should therefore obtain the latest version of relevant information from Cirrus Logic to verify that the information is current and complete. Testing and other quality control techniques are utilized to the extent Cirrus Logic deems necessary. Specific testing of all parameters of each device is not necessarily performed. In order to minimize risks associated with customer applications, the customer must use adequate design and operating safeguards to minimize inherent or procedural hazards. Cirrus Logic is not liable for applications assistance or customer product design. The customer is solely responsible for its product design, including the specific manner in which it uses Cirrus Logic components, and certain uses or product designs may require an intellectual property license from a third party. Features and operations described herein are for illustrative purposes only and do not constitute a suggestion or instruction to adopt a particular product design or a particular mode of operation for a Cirrus Logic component.

CERTAIN APPLICATIONS USING SEMICONDUCTOR PRODUCTS MAY INVOLVE POTENTIAL RISKS OF DEATH, PERSONAL INJURY, OR SEVERE PROPERTY OR ENVIRONMENTAL DAMAGE ("CRITICAL APPLICATIONS"). CIRRUS LOGIC PRODUCTS ARE NOT DESIGNED, AUTHORIZED OR WARRANTED FOR USE IN PRODUCTS SURGICALLY IMPLANTED INTO THE BODY, AUTOMOTIVE SAFETY OR SECURITY DEVICES, NUCLEAR SYSTEMS, LIFE SUPPORT PRODUCTS OR OTHER CRITICAL APPLICATIONS. INCLUSION OF CIRRUS LOGIC PRODUCTS IN SUCH APPLICATIONS IS UNDERSTOOD TO BE FULLY AT THE CUSTOMER'S RISK AND CIRRUS LOGIC DISCLAIMS AND MAKES NO WARRANTY, EXPRESS, STATUTORY OR IMPLIED, INCLUDING THE IMPLIED WARRANTIES OF MERCHANTABILITY AND FITNESS FOR PARTICULAR PURPOSE, WITH REGARD TO ANY CIRRUS LOGIC PRODUCT THAT IS USED IN SUCH A MANNER. IF THE CUSTOMER OR CUSTOMER'S CUSTOMER USES OR PERMITS THE USE OF CIRRUS LOGIC PRODUCTS IN CRITICAL APPLICATIONS, CUSTOMER AGREES, BY SUCH USE, TO FULLY INDEMNIFY CIRRUS LOGIC, ITS OFFICERS, DIRECTORS, EMPLOYEES, DISTRIBUTORS AND OTHER AGENTS FROM ANY AND ALL LIABILITY, INCLUDING ATTORNEYS' FEES AND COSTS, THAT MAY RESULT FROM OR ARISE IN CONNECTION WITH THESE USES.

This document is the property of Cirrus Logic, and you may not use this document in connection with any legal analysis concerning Cirrus Logic products described herein. No license to any technology or intellectual property right of Cirrus Logic or any third party is granted herein, including but not limited to any patent right, copyright, mask work right, or other intellectual property rights. Any provision or publication of any third party's products or services does not constitute Cirrus Logic's approval, license, warranty or endorsement thereof. Cirrus Logic gives consent for copies to be made of the information contained herein only for use within your organization with respect to Cirrus Logic integrated circuits or other products of Cirrus Logic, and only if the reproduction is without alteration and is accompanied by all associated copyright, proprietary and other notices and conditions (including this notice). This consent does not extend to other copying such as copying for general distribution, advertising or promotional purposes, or for creating any work for resale. This document and its information is provided "AS IS" without warranty of any kind (express or implied). All statutory warranties and conditions are excluded to the fullest extent possible. No responsibility is assumed by Cirrus Logic for the use of information herein, including use of this information as the basis for manufacture or sale of any items, or for infringement of patents or other rights of third parties. Cirrus Logic, Cirrus, the Cirrus Logic logo design, and SoundClear are among the trademarks of Cirrus Logic. Other brand and product names may be trademarks or service marks of their respective owners.

Copyright © 2003–2020 Cirrus Logic, Inc. All rights reserved.

REVISION HISTORY

DATE	REV	ORIGINATOR	DESCRIPTION OF CHANGES	CHANGED PAGES
08/12/05	4.0	JmacD	Updated to Production Data Electrical Characteristics – midrail ref voltage and buffered ref voltage max/min changed from +/-3% to +/-4%	6
25/7/06	4.1	DM	Added TSSOP references	1,3
			Added TSSOP package diagram	20
			Updated abs max table with digital supply max 4.5V, ambient temperature supplies applied, storage temperature, soldering temperatures per Ian Smith's input	5
			Added thermal performance table	5
			Moved operating temperature range from abs max to recommended operating conditions	5
25/07/06	4.1	JmacD	Updated Important Notice	21
03/08/06	4.2	JmacD	Thermal Performance – Thermal resistance – junction to case removed and notes updated.	5
24/08/07	4.3	IanD	Added 'I' grade data for ADC and DAC	8
			Added 'I' grade part numbers and notes	3
			Added to feature description on front page and added part numbers for SNR and DNR (since they do not apply to 'I' grade devices.+)	FRONT
			Reduced AVDD current to 26mA	9
			Increased Rvmid to 70K	9
			Added description of FSAMEN pin	16
27/08/07	4.3	IanD	Changed SNR to 100dB, THD to -93dB on recommendation from test	Front sheet
			Changed all TYP values to be the same – recommendation from test.	8,9
			Corrected table formatting – it went bananas – in electrical characteristics table	6,7
28/08/07	4.3	IanD	Removed SNR min A-weighted at fs=96KHz. This is not tested at ATE	6
			Removed reference to WM8782SIDS since we are limiting the 'I' grade devices to TSSOP	all
06/09/07	4.4	Ian D	Changed temp range for SED/GED devices back to -25 degrees	Front sheet,P3 and P6
20/03/08	4.5	JMacD	Ordering Info: Removed 'I' Grade references. Changed temp range to -40°C	3
			Recommended Operating Conditions: Removed 'I' Grade references and changed operating temp to -40	6
			Electrical Characteristics – removed 'I' Grade References – to be done	7
28/04/08	4.5	Ian D	Added clarification note on the recommended components page. Removed reference to -25° device on front page	19 1
29/04/08	4.5	Ian D	Removed all reference to i-grade performance data	7
			Added ADC phase inversion comment	10
06/08/08	4.6	JMacD	Order Info: WM8782SEDS and WM8782SEDS/R changed to WM8782SEDS/V and WM8782SEDS/RV MSL updated from MSL1 to MSL2	3
			Pin Description, Pin 8 Description 'ken' corrected to 'kHz'	4

DATE	REV	ORIGINATOR	DESCRIPTION OF CHANGES	CHANGED PAGES
13/04/10	4.7	BT	Added Slave mode MCLK/BCLK timing relationship, detailing keep-out areas for MCLK edge to BCLK falling edge.	10
		BT	Added simulated switching level ranges for MCLK and BCLK pins	10
		BT	Edited FSAMPEN section to clarify FSAMPEN pin operation	13
		BT	Removed WM8782GEDT and WM8782GEDT/R from Order Info, Recommended Operating Conditions and Electrical Characteristics	3,6
		BT	Removed all references to TSSOP	
17/01/20	4.8	PH	Ordering Information and Absolute Maximum Ratings updated – MSL information removed	3, 5

X-ON Electronics

Largest Supplier of Electrical and Electronic Components

Click to view similar products for [Audio A/D Converter ICs](#) category:

Click to view products by [Cirrus Logic](#) manufacturer:

Other Similar products are found below :

[WM8788GEDT](#) [WM8782SEDS/RV](#) [ADAU1977WBCPZ](#) [ADAU7112ACBZR7](#) [ADAU1979WBCPZ-RL](#) [ADAU7118ACPZRL7](#) [CS5340-CZZR](#) [CS5343-CZZ](#) [CS5343-CZZR](#) [CS5381-KSZ](#) [CS5366-CQZ](#) [PCM1800E](#) [PCM1801U](#) [PCM1803ADBDR](#) [PCM1804DBG4](#) [PCM1804DBR](#) [PCM1804S1IDBRQ1](#) [PCM1807PW](#) [PCM1808PWR](#) [PCM1860DBT](#) [PCM1861DBT](#) [PCM1862DBTR](#) [PCM1863DBT](#) [PCM1863DBTR](#) [PCM1864DBT](#) [PCM1864DBTR](#) [PCM1865DBT](#) [PCM1865DBTR](#) [PCM1870AYZFT](#) [PCM1870RHFR](#) [PCM1870RHFT](#) [PCM4201PW](#) [PCM4204PAPT](#) [PCM4220PFB](#) [TLV320ADC3001IYZHR](#) [TLV320ADC3001IYZHT](#) [TLV320ADC3100IRGET](#) [TLV320ADC3101IRGER](#) [PCM4222PFBR](#) [PCM1861QDBTRQ1](#) [CS53L30-CNZ](#) [PCM1808PWRG4](#) [PCM4222PFB](#)