

CA-IS2062 3.75kV_{RMS} Isolated CAN Transceivers

with Integrated DC-DC Converter

1 Features

- **Meets the ISO 11898-2 physical layer standards**
- **Integrated DC-DC converter for cable-side power**
- **Integrated protection increases robustness**
 - 3.75kV_{RMS} withstand isolation voltage for 60s (galvanic isolation)
 - ±150kV/μs typical CMTI
 - ±58V fault-tolerant CANH and CANL
 - ±30V extended common-mode input range (CMR)
 - Transmitter dominant timeout prevents lockup, data rates down to 5.5 kbps
 - Thermal shutdown
 - Wide operating temperature range: -40°C to 125°C
- **Date rate is up to 1Mbps**
- **Operating from a single 5V supply on the logic side**
- **Low loop delay: 150ns (typical), 210ns (maximum)**
- **Ideal passive behavior when unpowered**
- **Wide-body SOIC16-WB(W) package**
- **Safety Regulatory Approvals**
 - VDE 0884-17 reinforced isolation
 - UL according to UL1577
 - TUV certification

2 Applications

- Industrial Controls
- Building Automation
- Security and Protection System
- Transportation
- Medical
- Telecom

3 General Description

The CA-IS2062 is galvanically-isolated CAN transceivers with a built-in isolated DC-DC converter, that eliminates the need for a separate isolated power supply in space constrained isolated designs. It has the logic input and output buffers separated by a silicon oxide (SiO₂) insulation barrier that provides up to 3.75kV_{RMS} (60s) of

galvanic isolation. Isolation improves communication by breaking ground loops and reduces noise where there are large differences in ground potential between ports.

The CA-IS2062 operates from a single 5V supply on the logic side. An integrated DC-DC converter generates the 5V operating voltage for the cable-side. This device does not require any external components other than bypass capacitors to realize an isolated CAN port. The transceivers operate up to 1Mbps data rate and feature integrated protection for robust communication, including current limit, thermal shutdown, and the extended ±58V fault protection on the CAN bus for equipment where overvoltage protection is required. The dominant timeout detection prevents bus lockup caused by controller error or by a fault on the TXD input. These CAN receivers also incorporate an input common-mode range (CMR) of ±30V, exceeding the ISO 11898 specification of -2V to +7V.

The CA-IS2062 is available in wide-body 16 pin SOIC(W) package, operates over -40°C to +125°C temperature range.

Device information

Part Number	Package	Package size (nominal value)
CA-IS2062W CA-IS2062VW	SOIC16-WB(W)	10.30 mm × 7.50 mm

Simplified functional block diagram

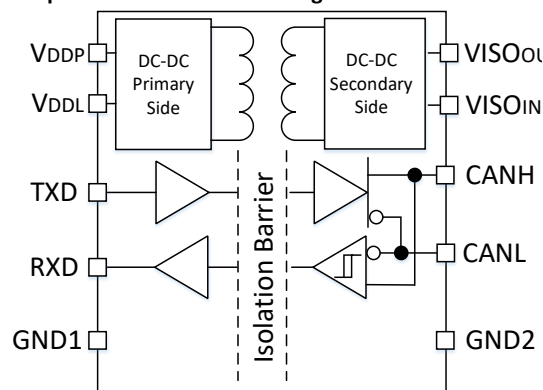

4 Ordering Information**Table 4-1 Ordering Information**

Part #	V _{CC} (V)	Data Rate (Mbps)	Galvanic Isolation (V _{RMS})	V _{CCL}	Package
CA-IS2062W	4.5~5.5	1	3750	No	SOIC16-WB(W)
CA-IS2062VW	4.5~5.5	1	3750	Yes	SOIC16-WB(W)

Contents

1	Features	1	9	Detailed Description	13
2	Applications	1	9.1	Overview	13
3	General Description	1	9.2	CAN Bus Status.....	13
4	Ordering Information	2	9.3	Receiver	13
5	Revision History	3	9.4	Transmitter.....	13
6	Pin Configuration and Functions	4	9.5	Protection Functions.....	14
7	Specifications	5	9.5.1	Signal Isolation	14
7.1	Absolute Maximum Ratings ¹	5	9.5.2	Thermal Shutdown.....	14
7.2	ESD Ratings.....	5	9.5.3	Current-Limit	14
7.3	Recommended Operating Conditions	5	9.5.4	Transmitter-Dominant Timeout	14
7.4	Thermal Information	5	10	Application Information	15
7.5	Insulation Specifications.....	6	11	Package Information	18
7.6	Safety-Related Certifications	7	12	Soldering Temperature (reflow) Profile	19
7.7	Electrical Characteristics	8	13	Tape and Reel Information	20
7.8	Switching Characteristics.....	9	14	Important Statement	21
8	Parameter Measurement Information	10			

5 Revision History

Revision Number	Description	Page Changed
Version 1.00	NA	NA
Version 1.01	Updated POD and UL certification information	7
Version 1.02	Updated typical application circuit and PCB layout information	19,20
Version 1.03	Update VDE,UL,TUV information	6, 7

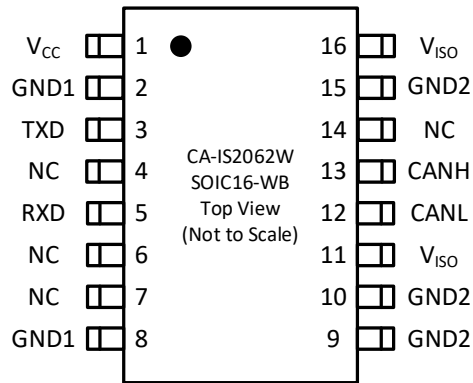
6 Pin Configuration and Functions

Figure 6-1 Pin Configuration
Table 6-1 CA-IS2062 Pin Configuration and Description

Pin name	Pin number	Type	Description
	SOIC16		
V _{CC}	1	Power supply	Power supply input for the logic side. Bypass V _{CC} to GND1 with 0.1μF//10μF capacitor as close to the device as possible.
GND1	2, 8	Ground	Logic side ground.
TXD	3	Digital I/O	Transmitter data input. CANH and CANL are in the dominant state when TXD is low. CANH and CANL are in the recessive state when TXD is high.
NC	4, 6, 7, 14	-	No connection, do not connect these pins and leave them open.
RXD	5	Digital I/O	Receiver output. RXD is high when the bus is in the recessive state. RXD is low when the bus is in the dominant state.
GND2	9, 10, 15	Ground	Bus side ground.
CANL	12	Differential I/O	Low-level CAN differential line.
CANH	13	Differential I/O	High-level CAN differential line.
V _{ISO}	11	Power supply input Pin	The power input pin for internal CAN, place a 1μF ceramic and keep the distance within 2mm. Connect this Pin to Pin16.
V _{ISO}	16	Power supply output Pin	Isolated power supply output, provide power for the cable-side. Bypass V _{ISO} to GND2 with 0.1μF//10μF capacitors as close to the device as possible.

7 Specifications

7.1 Absolute Maximum Ratings¹

Parameters		Minimum value	Maximum value	Unit
V _{CC} or V _{ISO}	Power supply voltage ²	-0.5	6.0	V
TXD or RXD to GND1	Logic side voltage (RXD, TXD)	-0.5	V _{CC} + 0.5 ³	V
CANH or CANL to GND2	Bus side voltage (CANH and CANL)	-40	40	V
I _o	Receiver output current	-15	15	mA
T _J	Junction temperature		150	°C
T _{STG}	Storage temperature range	-65	150	°C

Notes:

- The stresses listed under "Absolute Maximum Ratings" are stress ratings only, not for functional operation condition. Exposure to absolute maximum rating conditions for extended periods may cause permanent damage to the device.
- All voltage values except differential I/O bus voltages are with respect to the local ground (GND1 or GND2) and are peak voltage values.
- Maximum voltage must not be exceed 6 V.

7.2 ESD Ratings

		Numerical value	Unit
V _{ESD} Electrostatic discharge	Human body model (HBM), per ANSI/ESDA/JEDEC JS-001, all pins ¹	±5000	V
	Charged device model (CDM), per JEDEC specification JESD22-C101, all pins ²	±2000	

Notes:

- Per JEDEC document JEP155, 500V HBM allows safe manufacturing of standard ESD control process.
- Per JEDEC document JEP157, 250V CDM allows safe manufacturing of standard ESD control process.

7.3 Recommended Operating Conditions

Parameters		MIN	TYP	MAX	Unit
V _{CC}	Logic side power voltage	4.5	5	5.5	V
V _I or V _{IC}	Voltage at bus pins (separately or common mode)	-12		12	V
V _{IH}	Input high voltage	Driver (TXD)		V _{CC} + 0.3	V
V _{IL}	Input low voltage	Driver (TXD)		0.8	V
I _{OH}	High-level output current	Driver			mA
		Receiver		-2	
I _{OL}	Low-level output current	Driver		70	mA
		Receiver		2.5	
T _A	Ambient temperature	-40	25	125	°C
T _J	Junction temperature	-40		150	°C
P _D	Total power dissipation	V _{CC} = 5.5V, T _A = 125°C, R _L = 60Ω, TXD input is 500 kHz, 50% duty cycle square wave		900	mW
T _{J(shutdown)}	Thermal shutdown temperature ¹		165		°C

Note:

- Extended operation in thermal shutdown may affect device reliability.

7.4 Thermal Information

Heat meter		SOIC16-WB	Unit
R _{θJA}	Junction-to-ambient thermal resistance	86.5	°C/W

7.5 Insulation Specifications

Parameters		Test conditions	Value	Unit
CLR	External clearance ¹	Shortest terminal-to-terminal distance through air	8	mm
CPG	External creepage ¹	Shortest terminal-to-terminal distance across the package surface	8	mm
DTI	Distance through the insulation	Minimum internal gap (internal clearance)	28	μm
CTI	Comparative tracking index	DIN EN 60112 (VDE 0303-11); IEC 60112	>600	V
	Material group	Per IEC 60664-1	I	
	Overvoltage category per IEC 60664-1	Rated mains voltage $\leq 150 V_{RMS}$	I-IV	
		Rated mains voltage $\leq 300 V_{RMS}$	I-IV	
		Rated mains voltage $\leq 600 V_{RMS}$	I-IV	
		Rated mains voltage $\leq 1000 V_{RMS}$	I-III	
DIN V VDE V 0884-17:2021-10²				
V_{IORM}	Maximum repetitive peak isolation voltage	AC voltage (bipolar)	1414	V_{PK}
V_{IOWM}	Maximum operating isolation voltage	AC voltage; time-dependent dielectric breakdown (TDDb) test	1000	V_{RMS}
		DC voltage	1414	V_{DC}
V_{IOTM}	Maximum transient isolation voltage	$V_{TEST} = V_{IOTM}$, $t=60$ s (certified); $V_{TEST} = 1.2 \times V_{IOTM}$, $t=1$ s (100% product test)	5300	V_{PK}
V_{IOSM}	Maximum surge isolation voltage ³	Test method in accordance with IEC 60065, 1.2/50 μs waveform, $V_{TEST} = 1.3 \times V_{IOSM}$ (certified)	5000	V_{PK}
q_{pd}	Apparent charge	Method a, after input/output safety test of the subgroup 2/3, $V_{ini} = V_{IOTM}$, $t_{ini} = 60$ s; $V_{pd(m)} = 1.2 \times V_{IORM}$, $t_m = 10$ s	≤ 5	pC
		Method a, after environmental test of the subgroup 1, $V_{ini} = V_{IOTM}$, $t_{ini} = 60$ s; $V_{pd(m)} = 1.6 \times V_{IORM}$, $t_m = 10$ s	≤ 5	
		Method b, at routine test (100% production test) and preconditioning (type test) $V_{ini} = 1.2 \times V_{IOTM}$, $t_{ini} = 1$ s; $V_{pd(m)} = 1.5 \times V_{IORM}$, $t_m = 1$ s	≤ 5	
C_{IO}	Barrier capacitance, input to output ⁴	$V_{IO} = 0.4 \times \sin(2\pi ft)$, $f = 1$ MHz	~0.5	pF
R_{IO}	Isolation resistance	$V_{IO} = 500$ V, $T_A = 25^\circ\text{C}$	$>10^{12}$	Ω
		$V_{IO} = 500$ V, $100^\circ\text{C} \leq T_A \leq 125^\circ\text{C}$	$>10^{11}$	
		$V_{IO} = 500$ V at $T_S = 150^\circ\text{C}$	$>10^9$	
	Contaminant level		2	
UL²				
V_{ISO}	Maximum withstanding isolation voltage	$V_{TEST} = V_{ISO}$, $t = 60$ s (qualification) $V_{TEST} = 1.2 \times V_{ISO}$, $t = 1$ s (100% production test)	3750	V_{RMS}

Notes:

1. This coupler is suitable for "safe electrical insulation" only within the safety ratings. Compliance with the safety ratings shall be ensured by means of suitable protective circuits.
2. Devices are immersed in oil during surge characterization.
3. The characterization charge is discharging charge (pd) caused by partial discharge.
4. Capacitance and resistance are measured with all pins on field-side and logic-side tied together.

7.6 Safety-Related Certifications

VDE	UL	TUV
Certified according to DIN VDE V 0884-17:2021-10	Certified according to UL 1577 Component Recognition Program	Certified according to EN/IEC 61010-1:2010 (3rd Ed) and EN 60950-1:2006/A2:2013
Maximum transient isolation voltage: 5300V _{pk} Maximum repetitive peak isolation voltage: 1414V _{pk} Maximum surge isolation voltage: 5000V _{pk}	Maximum withstanding isolation voltage: 3750 V _{RMS}	2500 V _{RMS}
Certificate number: 40052786 (basic isolation)	Certificate number: E511334-20210507	Certificate number: CN23RC4J 001

7.7 Electrical Characteristics

 over recommended operating conditions (unless otherwise noted). All typical values are at 25°C with $V_{CC} = 5\text{ V}$.

Parameters		Test conditions	MIN	TYP	MAX	Unit
Power supply current						
I_{CC} Logic side power supply current	$V_I = 0\text{ V}$, $R_L = 60\ \Omega$ dominant timeout protection			90	120	mA
	$V_I = V_{CC}$			10	20	
Isolated Power Supply						
V_{ISO} Output voltage	No-load	$I_{ISO} = 0\text{ mA}$	4.65	5.05	5.47	V
Driver						
$V_{O(D)}$ Bus output voltage (dominant)	CANH	$V_I = 0\text{ V}$, $R_L = 60\ \Omega$; see <i>Figure 8-1</i> and <i>Figure 8-2</i> .	2.9	3.4	4.5	V
	CANL		0.5		2	
$V_{O(R)}$ Bus output voltage (recessive)		$V_I = 2\text{ V}$, $R_L = 60\ \Omega$; see <i>Figure 8-1</i> and <i>Figure 8-2</i> .	2	2.5	3	V
$V_{OD(D)}$ Differential output voltage (dominant)	$V_I = 0\text{ V}$, $R_L = 60\ \Omega$; see <i>Figure 8-1</i> , <i>Figure 8-2</i> and <i>Figure 8-3</i> .		1.5		3	V
	$V_I = 0\text{ V}$, $R_L = 45\ \Omega$; see <i>Figure 8-1</i> , <i>Figure 8-2</i> and <i>Figure 8-3</i> .		1.3		3	V
$V_{OD(R)}$ Differential output voltage (recessive)	$V_I = 3\text{ V}$, $R_L = 60\ \Omega$; see <i>Figure 8-1</i> and <i>Figure 8-2</i> .		-80		80	mV
	$V_I = 3\text{ V}$, no-load.		-0.05		0.05	V
$V_{OC(D)}$ Common mode output voltage (dominant)	See <i>Figure 8-7</i>		2	2.5	3	V
$V_{OC(PP)}$ Peak to peak common mode output voltage					60	
I_{IH} High-level input current, TXD input	$V_I = 2\text{ V}$				20	μA
I_{IL} Low-level input current, TXD input	$V_I = 0.8\text{ V}$		-20			μA
$I_{OS(SS)}$ Short-circuit steady-state output current	$V_{CANH} = -30\text{ V}$, CANL open; see <i>Figure 8-10</i> .		-105	-36		mA
	$V_{CANH} = 30\text{ V}$, CANL open; see <i>Figure 8-10</i> .			0.6	2	
	$V_{CANL} = -30\text{ V}$, CANH open; see <i>Figure 8-10</i> .		-2	-0.6		
	$V_{CANL} = 30\text{ V}$, CANH open; see <i>Figure 8-10</i> .			42	105	
CMTI (Common Mode Transient Immunity)		$V_I = 0\text{ V}$ or V_{CC} ; see <i>Figure 8-11</i> .	100	150		kV/ μs
Receiver						
V_{IT+} Positive-going bus input threshold voltage				0.8	0.9	V
V_{IT-} Negative-going bus input threshold voltage			0.5	0.65		V
V_{HYS} Hysteresis voltage			50	125		mV
V_{OH} High-level output voltage	$I_{OH} = -4\text{ mA}$; see <i>Figure 8-6</i> .		$V_{CC} - 0.8$	4.8		V
	$I_{OH} = -20\ \mu\text{A}$; see <i>Figure 8-6</i> .		$V_{CC} - 0.1$	5		
V_{OL} High-level output voltage	$I_{OL} = 4\text{ mA}$; see <i>Figure 8-6</i> .			0.2	0.4	V
	$I_{OL} = 20\ \mu\text{A}$; see <i>Figure 8-6</i> .			0	0.1	
C_i CANH or CANL input capacitance to ground	$V_{TXD} = 3\text{ V}$, $V_I = 0.4\text{ x sin}(2\pi\text{ft}) + 2.5\text{ V}$, $f = 1\text{ MHz}$			24		pF
C_{ID} Differential input capacitance	$V_{TXD} = 3\text{ V}$, $V_I = 0.4\text{ x sin}(2\pi\text{ft})$, $f = 1\text{ MHz}$			12		pF
R_{IN} CANH and CANL input capacitance	$V_{TXD} = 3\text{ V}$		15		40	k Ω
R_{ID} Differential input resistance	$V_{TXD} = 3\text{ V}$		30		80	k Ω
$R_{I(m)}$ Input resistance matching ($1 - [R_{IN(CANH)} / R_{IN(CANL)}]$) x 100%	$V_{CANH} = V_{CANL}$		-2%	0%	2%	
CMTI Common mode transient immunity		$V_I = 0\text{ V}$ or V_{CC} ; see <i>Figure 8-11</i> .	100	150		kV/ μs

7.8 Switching Characteristics

over recommended operating conditions (unless otherwise noted). All typical values are at 25°C with $V_{CC} = 5\text{ V}$.

Parameters		Test conditions	MIN	TYP	MAX	Unit
Device						
t_{loop1}	Total loop delay, driver input (TXD) to receiver output (RXD), recessive to dominant	see Figure 8-8.	110	150	210	ns
t_{loop2}	Total loop delay, driver input (TXD) to receiver output (RXD), dominant to recessive		110	150	210	ns
Driver						
t_{PLH}	TXD propagation delay (recessive to dominant)	see Figure 8-4.	35	75	130	ns
t_{PHL}	TXD propagation delay (dominant to recessive)		35	55	100	
t_r	Differential driver output rise time			55	100	
t_f	Differential driver output fall time			60	105	
$t_{TXD_DTO}^1$	TXD dominant timeout	$C_L = 100\text{ pF}$; see Figure 8-9.	2	5	8	ms
Receiver						
t_{PLH}	RXD propagation delay (recessive to dominant)	see Figure 8-6.		85	140	ns
t_{PHL}	RXD Propagation delay (dominant to recessive)			60	140	
t_r	RXD Output signal rise time			2.5	6	
t_f	RXD Output signal fall time			2.5	6	
Note:						
1. The TXD dominant time out (t_{TXD_DTO}) disables the driver of the transceiver once the TXD has been dominant longer than (t_{TXD_DTO}) which releases the bus lines to recessive preventing a local failure from locking the bus dominant.						

8 Parameter Measurement Information

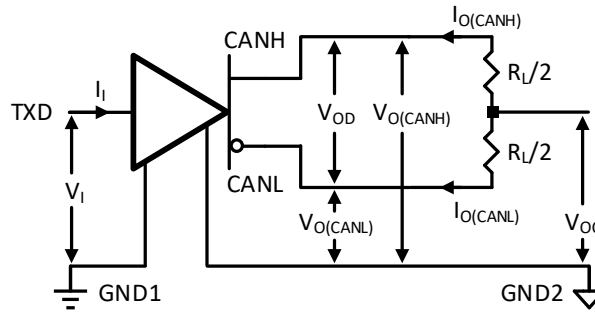

Figure 8-1 Driver Voltage and Current Definition

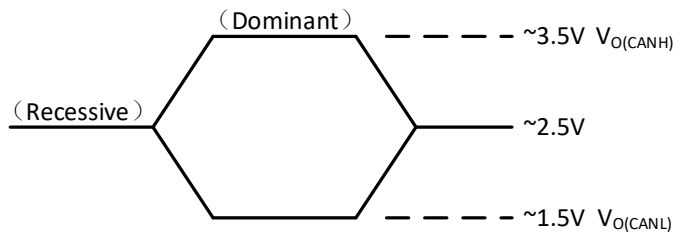

Figure 8-2 Bus Logic State Voltage Definition

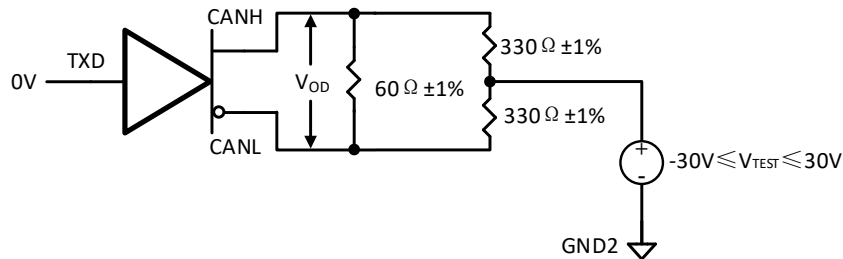
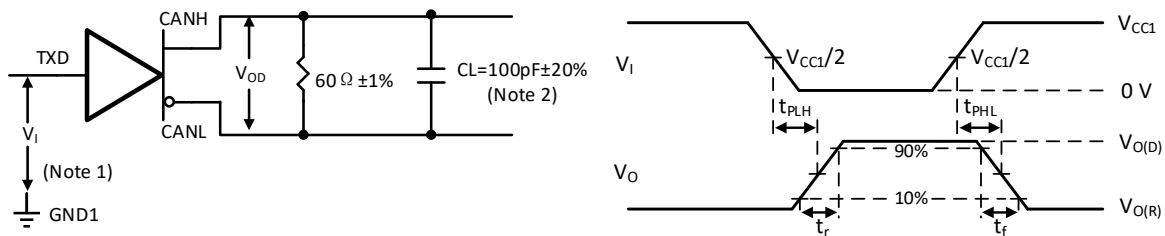

Figure 8-3 Driver V_{OD} with Common Mode Loading Test Circuit



Notes:

1. The input pulse is supplied by a generator with characteristics: PRR ≤ 125 kHz, 50% duty cycle; rise time $t_r \leq 6$ ns, fall time $t_f \leq 6$ ns; $Z_o = 50\Omega$.
2. Load capacitance C_L includes external circuit (instrumentation and fixture etc.) capacitance.

Figure 8-4 Transmitter Test Circuit and Timing Diagram

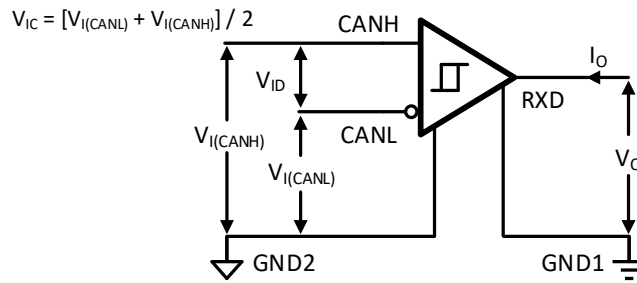
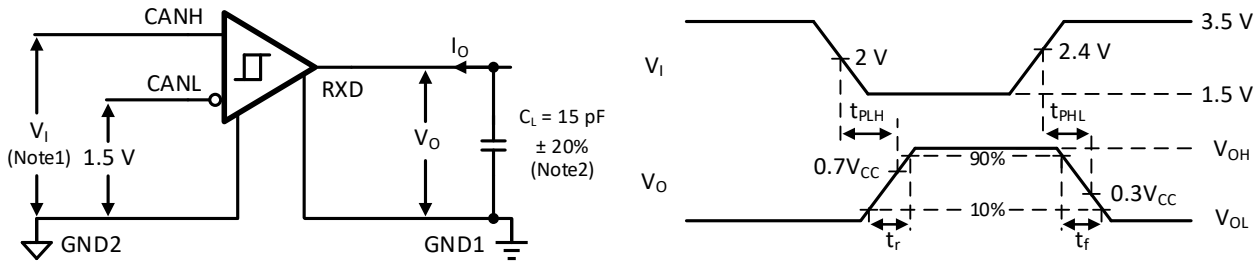

Figure. 8-5 Receiver Voltage and Current Definition



Notes:

1. The input pulse is supplied by a generator with characteristics: PRR ≤ 125 kHz, 50% duty cycle; rise time $t_r \leq 6$ ns, fall time $t_f \leq 6$ ns; $Z_o = 50 \Omega$.
2. Load capacitance C_L includes external circuit (instrumentation and fixture etc.) capacitance.

Figure. 8-6 Receiver Test Circuit and Timing Diagram

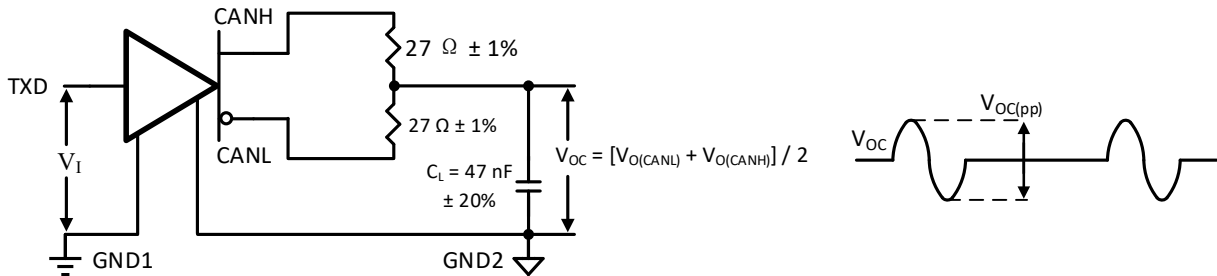

Figure. 8-7 Peak-to-Peak Output Voltage Test Circuit and Waveform

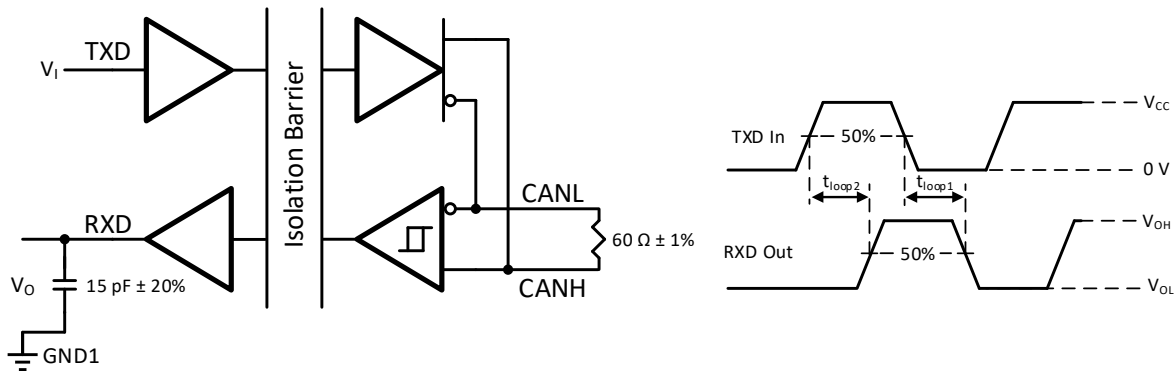
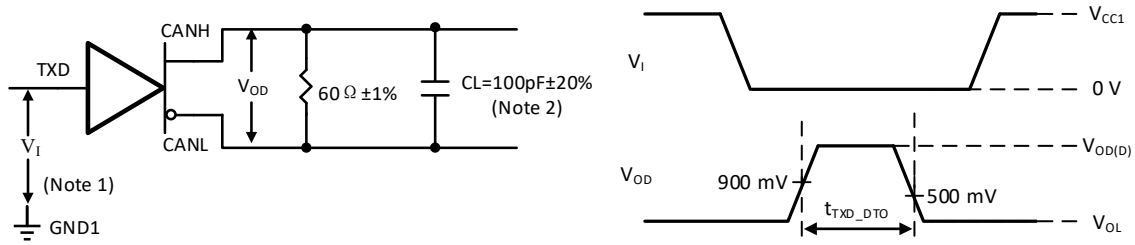

Figure. 8-8 TXD to RXD Loop Delay



Notes:

1. The input pulse is supplied by a generator with characteristics: PRR \leq 125 kHz, 50% duty cycle; rise time $t_r \leq 6$ ns, fall time $t_f \leq 6$ ns; $Z_0 = 50 \Omega$.
2. Load capacitance C_L includes external circuit (instrumentation and fixture etc.) capacitance.

Figure. 8-9 Transmitting Dominant Timeout Timing Diagram

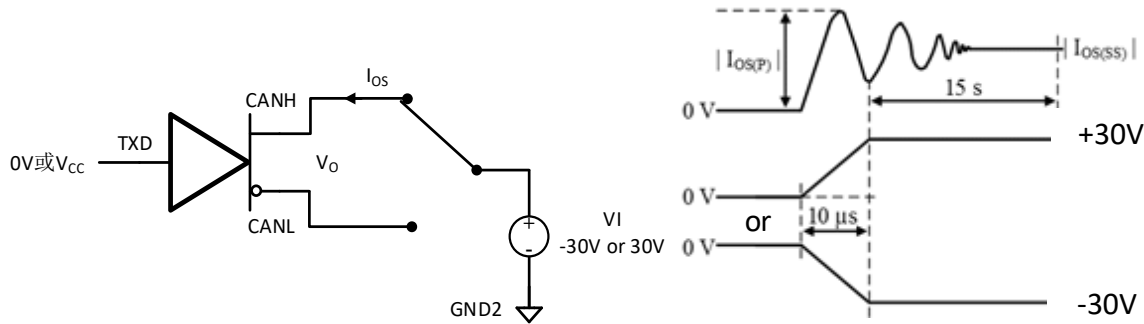

Figure. 8-10 Driver Short Circuit Current Test Circuit and Measurement

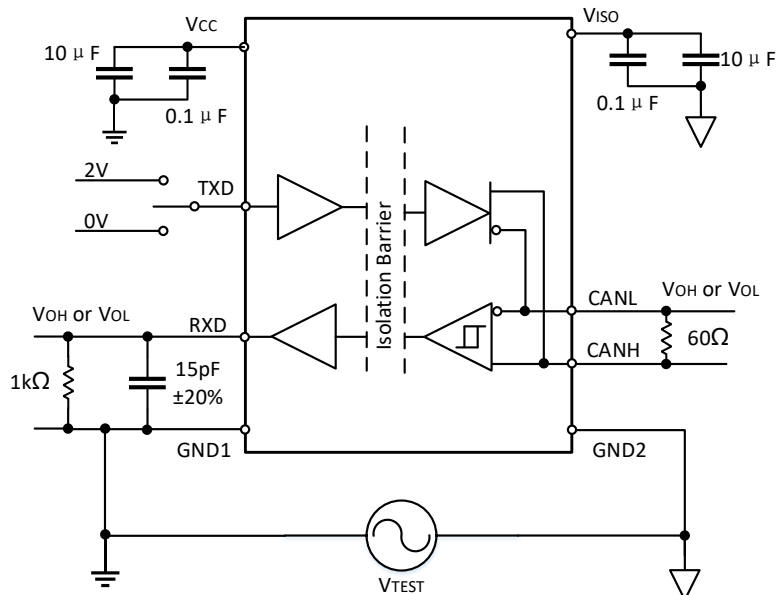

Figure. 8-11 Common-Mode Transient Immunity Test Circuit

9 Detailed Description

9.1 Overview

The CA-IS2062 isolated CAN transceiver provides up to $2500V_{RMS}$ (60s) of galvanic isolation between the CAN cable-side of the transceiver and the logic-side. This integrated transceiver is suitable for applications that have limited board space and require more integration. Only external bypass capacitors are needed to fully realize an isolated CAN port. The device features up to $150\text{ kV}/\mu\text{s}$ common mode transient immunity, allow up to 1Mbps communication across an isolation barrier. Robust isolation coupled with high standoff voltage and increased speeds enables efficient communication in noisy environments, making it ideal for communication with the microcontroller in a wide range of applications such as industrial control, building automation, telecom rectifiers, HVACs etc. industrial applications. The supply voltage range for the logic side is 4.5V to 5.5V (V_{CC}); Power isolation is achieved with an integrated DC-DC convertor to generate a regulated 5V supply for the cable-side. The receiver input common-mode range is $\pm 30\text{V}$, exceeding the ISO 11898 specification of -2V to +7V, and the fault tolerant is up to $\pm 58\text{V}$. Dominant timeout prevents the bus from being blocked by a hung-up microcontroller, and the outputs CANH and CANL are short-circuit current-limited, protected against excessive power dissipation by thermal shutdown circuitry that places the driver outputs in a high-impedance state.

9.2 CAN Bus Status

The CAN bus has two states: dominant and recessive. In the dominant state (a zero bit, used to determine message priority), CANH-CANL are defined to be logic '0' when the voltage across them is between +1.5V and +3V (higher than 0.9V). In the recessive state (a 1-bit and the state of the idle bus), the driver is defined to be logic '1' when differential voltage is between -120mV and +12mV, or when it is near zero (lower than 0.5V), see *Figure 8-2*.

9.3 Receiver

The receiver reads the differential input from the bus line (CANH and CANL) and transfers this data as a single-ended output RXD to the CAN controller. The internal comparator senses the difference voltage $V_{DIFF} = (V_{CANH} - V_{CANL})$, with respect to an internal threshold of 0.7V. If $V_{DIFF} > 0.9\text{V}$, a logic-low is present on RXD; If $V_{DIFF} < 0.5\text{V}$, a logic-high is present. The CANH and CANL common-mode range is $\pm 30\text{V}$ in normal mode. RXD is a logic-high when CANH and CANL are shorted or terminated and un-driven. See *Table 9-1*.

Table 9-1 Receiver Truth Table

$V_{ID} = V_{CANH} - V_{CANL}$	BUS STATE	RXD
$V_{ID} \geq 0.9\text{V}$	Dominant	Low
$0.5\text{V} < V_{ID} < 0.9\text{V}$	Indeterminate	Indeterminate
$V_{ID} \leq 0.5\text{V}$	Recessive	High
Open ($V_{ID} \approx 0\text{V}$)	Open	High

9.4 Transmitter

The transmitter converts a single-ended input signal (TXD) from the local CAN controller to differential outputs for the bus lines CANH and CANL. The truth table for the transmitter is provided in *Table 9-2*. CANH and CANL outputs are short-circuit current limited and are protected against excessive power dissipation by thermal shutdown circuitry that places the driver outputs in a high-impedance state.

Table 9-2 Transmitter Truth Table (When Not Connected to the Bus)

V_{CC}	INPUT	TXD LOW TIME	OUTPUT		BUS STATE
	TXD		CANH	CANL	
Power Up	Low	$< t_{TXD_DTO}$	High	Low	Dominant
	Low	$> t_{TXD_DTO}$	$V_{ISO}/2$	$V_{ISO}/2$	Recessive
	High or Open	X	$V_{ISO}/2$	$V_{ISO}/2$	Recessive
Power Down	X	X	Hi-Z	Hi-Z	Hi-Z

X = Don't care, Hi-Z = high-impedance.

9.5 Protection Functions

9.5.1 Signal Isolation

The CA-IS2062 devices integrated digital galvanic isolators using Chipanalog's capacitive isolation technology based on the ON-OFF keying (OOK) modulation scheme, allow data transmission between the controller side and cable side of the transceiver with different power domains. Also, the power isolation is achieved with an integrated DC-DC convertor to generate a regulated 5V supply for the cable-side.

9.5.2 Thermal Shutdown

If the junction temperature of the CA-IS2062 device exceeds the thermal shutdown threshold $T_{J(\text{shutdown})}$ (165°C, typ.), the device turns off the CAN driver circuits thus blocking the TXD-to-bus transmission path. The CAN bus terminals are biased to the recessive level during a thermal shutdown, and the receiver-to-RXD path remains operational. The shutdown condition is cleared when the junction temperature drops to normal operation temperature range of the device.

9.5.3 Current-Limit

The CA-IS2062 protect the transmitter output stage against a short-circuit to a positive or negative voltage by limiting the driver current. However, this will cause large supply current and dissipation. Thermal shutdown further protects the devices from excessive temperatures that may result from a short circuit. The transmitter returns to normal operation once the short is removed.

9.5.4 Transmitter-Dominant Timeout

The CA-IS2062 devices feature a transmitter-dominant timeout ($t_{\text{TXD_DTO}}$) that prevents erroneous CAN controllers from clamping the bus to a dominant level by maintaining a continuous low TXD signal. When TXD remains in the dominant state (low) for greater than $t_{\text{TXD_DTO}}$, the transmitter is disabled, releasing the bus to a recessive state. After a dominant timeout fault, the transmitter is re-enabled when receiving a rising edge at TXD. The CAN protocol allows a maximum of eleven successive dominant bits (on TXD) for the worst case, where five successive dominant bits are followed immediately by an error frame. So the minimum transmitted data rate can be calculated as: $11 \text{ bits}/t_{\text{TXD_DTO}} = 11 \text{ bits} / 2\text{ms} = 5.5\text{kbps}$. The transmitter-dominant timeout limits the minimum possible data rate of the CA-IS2062 to 5.5kbps.

10 Application Information

CAN interface has been a very popular serial communication standard in the industry and automotive applications due to its excellent prioritization and arbitration capabilities. In systems with different voltage domains, isolation is typically used to protect the low voltage side from the high voltage side in case of any faults. The CA-IS2062x provide complete isolated solution for these kind of applications, see Figure 10-1 the typical application circuit.

The CA-IS2062x devices can operate up to 1Mbps data rate. However, the maximum data rate is limited by the bus loading, number of nodes, cable length etc. factors. For CAN network design, margin must be given for signal loss across the system and cabling, parasitic loadings, timing, network imbalances, ground offsets and signal integrity thus a practical maximum data rate, number of nodes often lower. The ISO11898 Standard specifies a maximum of 30 nodes. However, with careful design, and consider of high input impedance of the CA-IS2062x, designers can have many more nodes (up to 110) on the CAN bus.

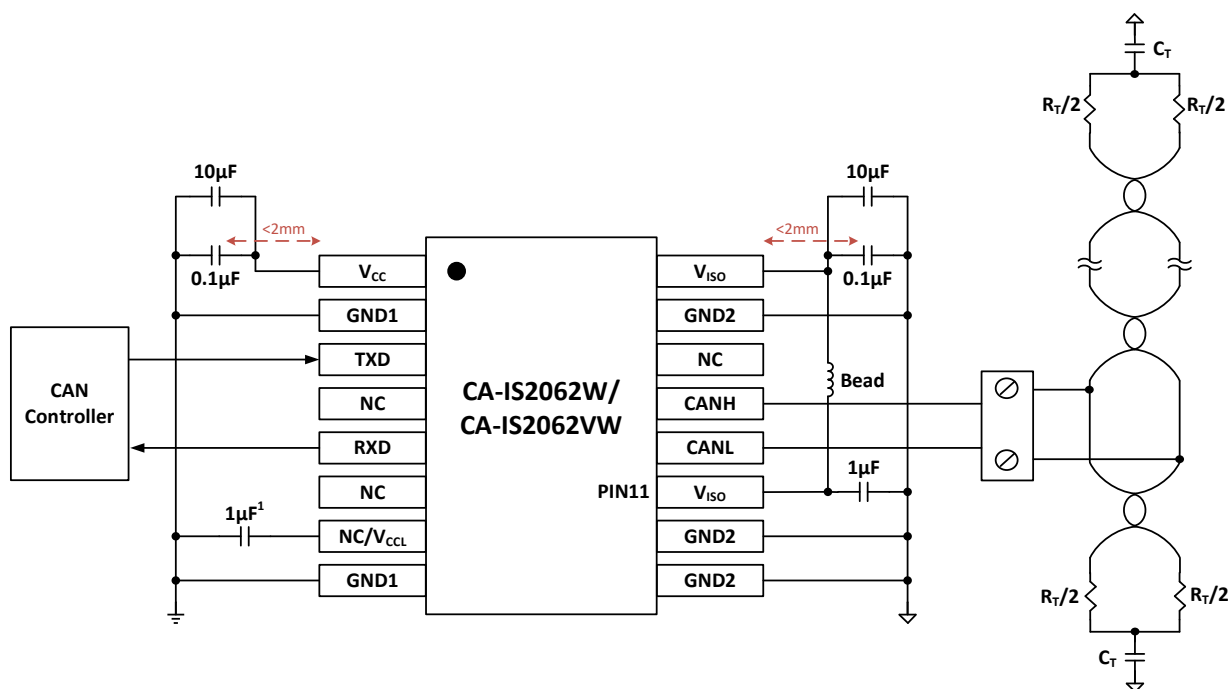
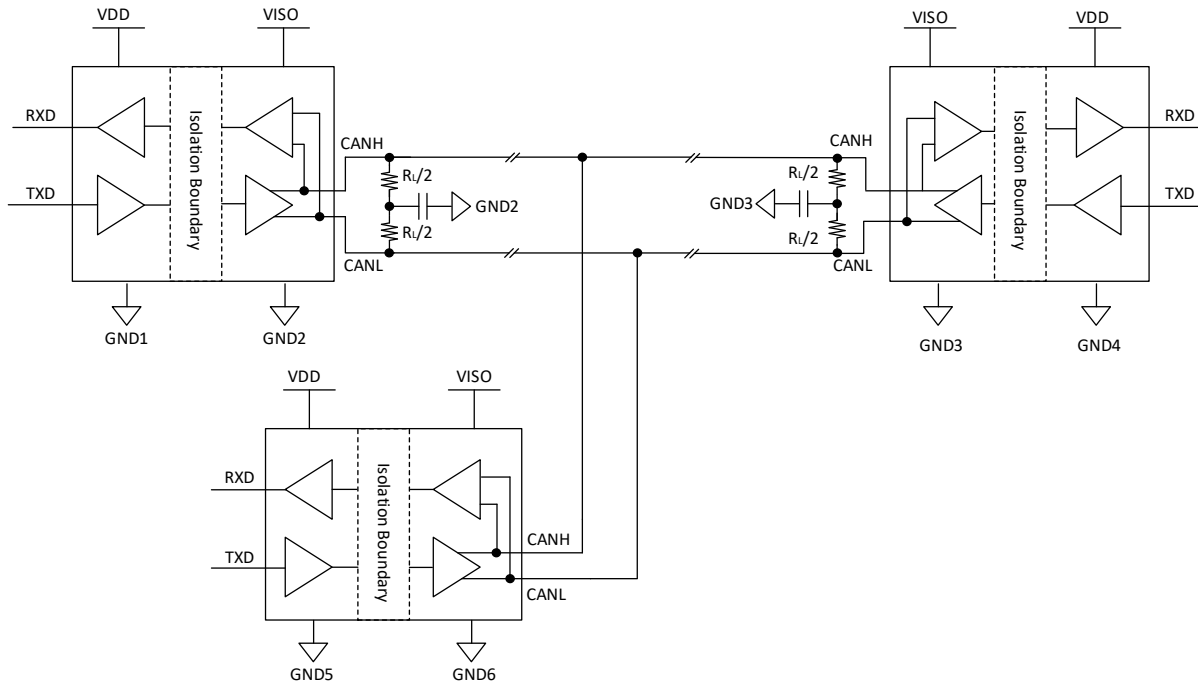

Figure 10- 1 Typical Application Circuit

In multi-drop CAN applications, it is important to maintain a single linear bus of uniform impedance that is properly terminated at each end. A star, ring, or tree configuration should never be used. Any deviation from the end-to-end wiring scheme creates a stub. High-speed data edges on a stub can create reflections back down to the bus. These reflections can cause data errors by eroding the noise margin of the system. Although stubs are unavoidable in a multi-drop system, care should be taken to keep these stubs as short as possible, especially when operating with high data rates. See Figure 10-2, the typical CAN bus operating circuit, termination may be a single 120Ω resistor (R_T) at the end of the bus, either on the cable or in a terminating node; or split termination, the two 60Ω termination resistors in parallel may be used if filtering and stabilization of the common mode voltage of the bus is desired.

Figure 10- 2 Typical CAN Bus Operating Circuit

To ensure reliable operation at all data rates, it is strongly recommended to bypass V_{CC} and V_{ISO} with $0.1\mu\text{F} \parallel 10\mu\text{F}$ low-ESR ceramic capacitors to GND1 and GND2 respectively. Place the bypass capacitors as close to the power supply input/output pins as possible. The PCB designer should follow some critical recommendations in order to get the best performance from the design. For the high-speed operating digital circuit boards, we recommend to use the standard FR-4 PCB material and a minimum of four layers is required to accomplish a low EMI PCB design. Also, keep the input/output traces as short as possible, avoid using vias to make low-inductance paths for the signals. For harsh industrial environments, external protection might be necessary to protect the CAN transceiver during normal operation. If the $10\mu\text{F}$ ceramic capacitor can't be placed for some reason, a $4.7\mu\text{F}$ ceramic capacitor is the minimal value needed. Place the $10\mu\text{F}$ ceramic close to V_{CC} and V_{ISO} pins and keep distance within 2mm. The input/output ceramic capacitor and the IC must be placed on the same PCB layer and connected without any vias to reduce parasite. The recommended PCB layout of CA-IS2062VW is shown in Figure 10-3. For the logic supply input, we recommend to use a $1\mu\text{F}$ ceramic capacitors with X5R or X7R between V_{CC1} pin and GND1. V_{ISO} (PIN11) is power pin for CAN module inside, place a $1\mu\text{F}$ ceramic capacitors as close as possible to this pin.

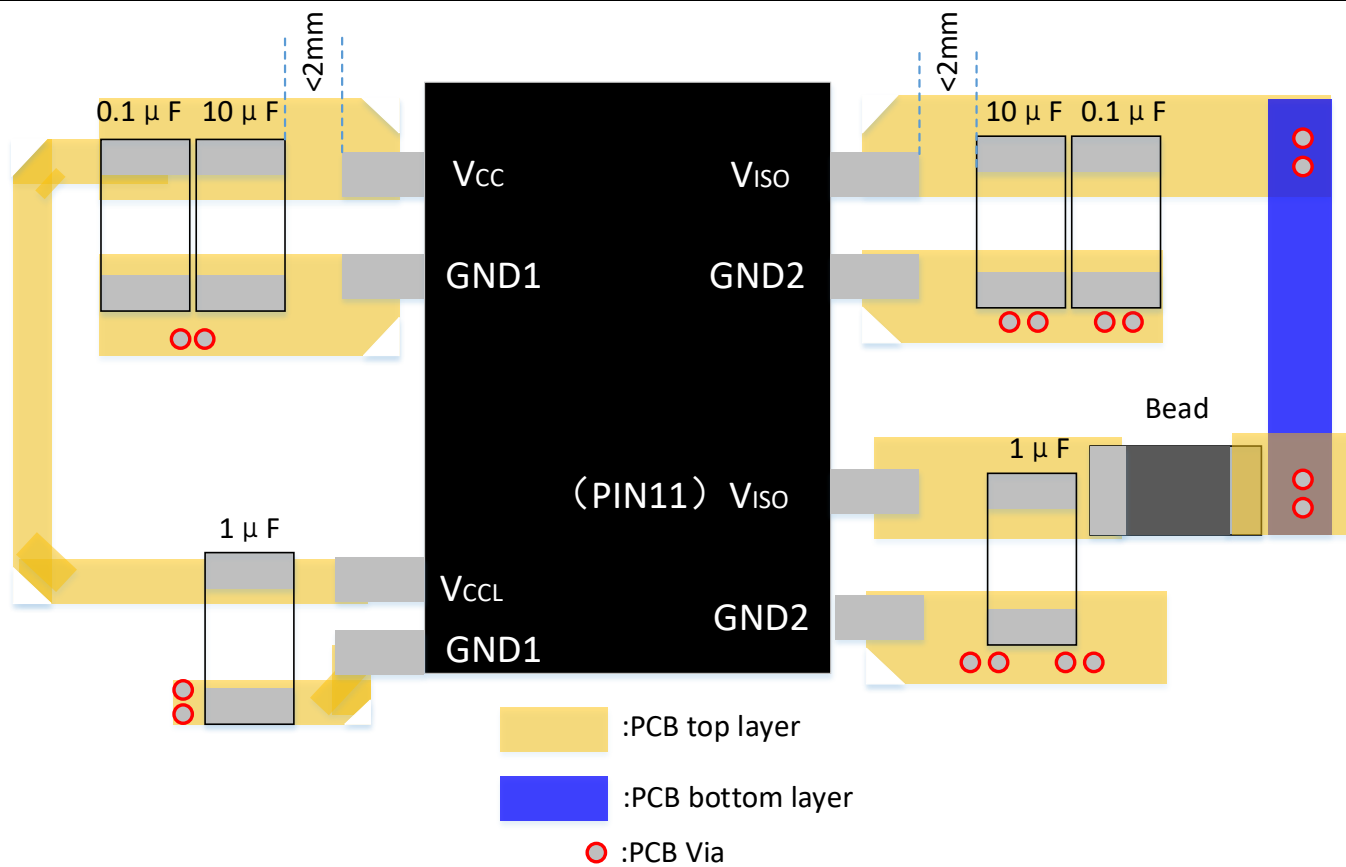
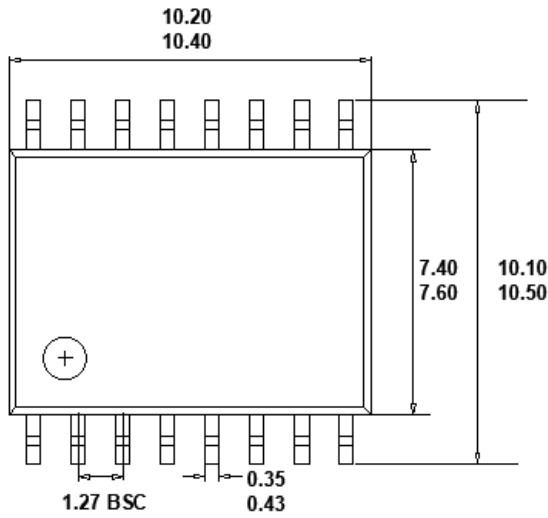

Figure 10- 3 Recommended PCB layout of isolated power

11 Package Information

Wide-body SOIC16 Package Outline



TOP VIEW

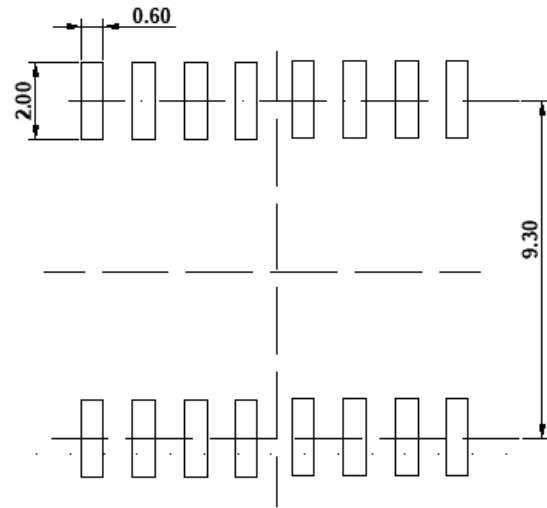

RECOMMENDED LAND PATTERN

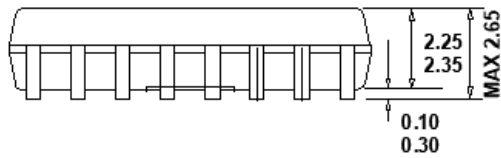

FRONT VIEW

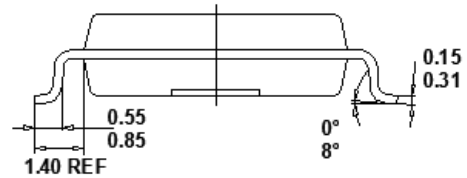

LEFT SIDE VIEW

Note:

1. All dimensions are in millimeters, angles are in degrees.

12 Soldering Temperature (reflow) Profile

Figure. 12-1 Soldering Temperature (reflow) Profile

Tab.12- 1 Soldering Temperature Parameter

Profile Feature	Pb-Free Assembly
Average ramp-up rate(217 °C to Peak)	3°C /second max
Time of Preheat temp(from 150 °C to 200 °C)	60-120 second
Time to be maintained above 217 °C	60-150 second
Peak temperature	260 +5/-0 °C
Time within 5°C of actual peak temp	30 second
Ramp-down rate	6 °C /second max.
Time from 25°C to peak temp	8 minutes max

13 Tape and Reel Information
REEL DIMENSIONS

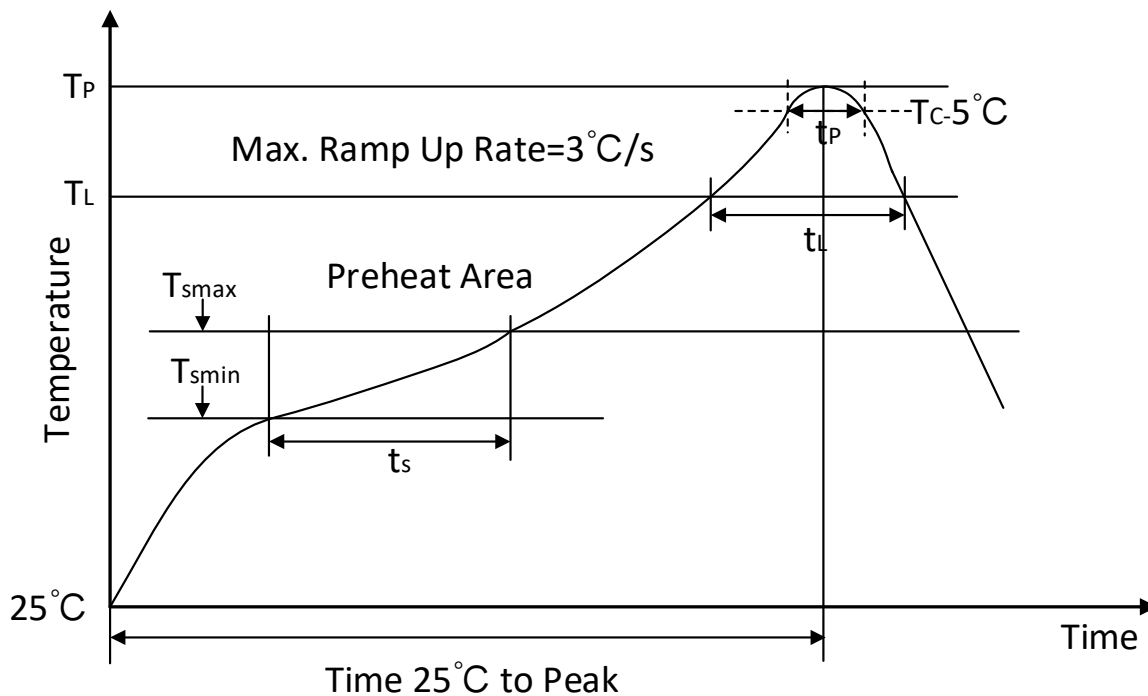
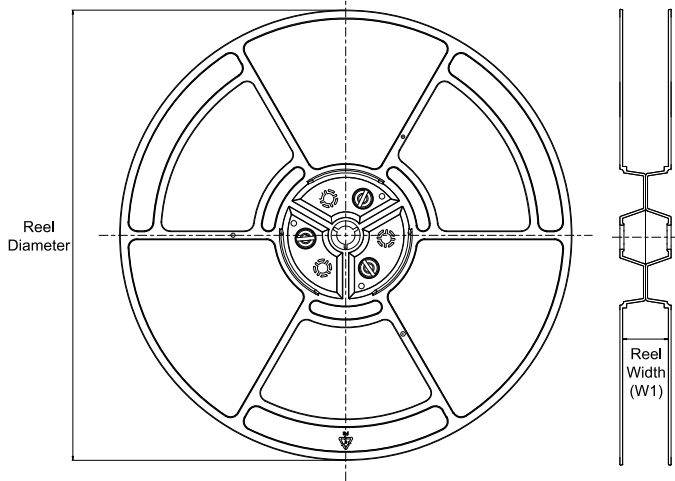
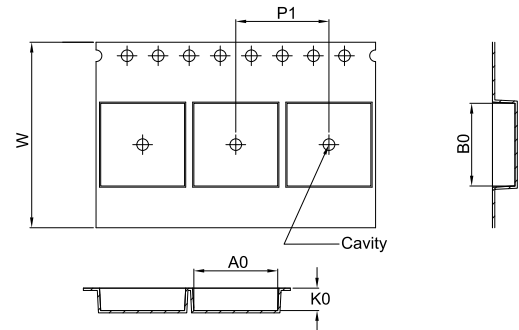
TAPE DIMENSIONS

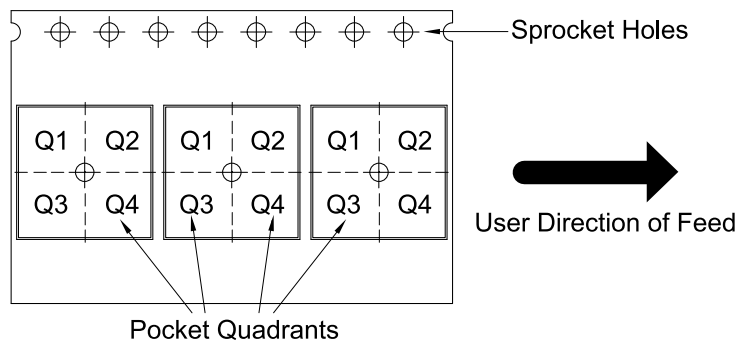
A0	Dimension designed to accommodate the component width
B0	Dimension designed to accommodate the component length
K0	Dimension designed to accommodate the component thickness
W	Overall width of the carrier tape
P1	Pitch between successive cavity centers

QUADRANT ASSIGNMENTS FOR PIN 1 ORIENTATION IN TAPE

*All dimensions are nominal

Device	Package Type	Package Drawing	Pins	SPQ	Reel Diameter (mm)	Reel Width W1 (mm)	A0 (mm)	B0 (mm)	K0 (mm)	P1 (mm)	W (mm)	Pin1 Quadrant
CA-IS2062W	SOIC	W	16	1000	330	16.4	10.9	10.7	3.2	12.0	16.0	Q1
CA-IS2062VW	SOIC	W	16	1000	330	16.4	10.9	10.7	3.2	12.0	16.0	Q1

14 Important Statement

The above information is for reference only and intended to help Chipanalog customers with design, research and development. Chipanalog reserves the rights to change the above information due to technological innovation without advance notice.

All Chipanalog products pass ex-factory test. As for specific practical applications, customers need to be responsible for evaluating and determining whether the products are applicable or not by themselves. Chipanalog's authorization for customers to use the resources are only limited to development of the related applications of the Chipanalog products. In addition to this, the resources cannot be copied or shown, and Chipanalog is not responsible for any claims, compensations, costs, losses, liabilities and the like arising from the use of the resources.

Trademark information

Chipanalog Inc.® and Chipanalog® are registered trademarks of Chipanalog.



<http://www.chipanalog.com>

X-ON Electronics

Largest Supplier of Electrical and Electronic Components

Click to view similar products for [Chipanalog](#) manufacturer:

Other Similar products are found below :

[CA-HP6025S](#) [CA-HP6041S](#) [CA-HP6050S](#) [CA-IF1021D-Q1](#) [CA-IF1021S-Q1](#) [CA-IF10283S-Q1](#) [CA-IF10285S-Q1](#) [CA-IF1042LS-Q1](#) [CA-IF1042LVS-Q1](#) [CA-IF1042S-Q1](#) [CA-IF1043DF-Q1](#) [CA-IF1043NF-Q1](#) [CA-IF1044D-Q1](#) [CA-IF1044S-Q1](#) [CA-IF1044VS-Q1](#) [CA-IF1051HS](#) [CA-IF1051S](#) [CA-IF1051S-Q1](#) [CA-IF1051VS](#) [CA-IF1051VS-Q1](#) [CA-IF4023](#) [CA-IF4220NF](#) [CA-IF4288](#) [CA-IF4420S](#) [CA-IF4805HS](#) [CA-IF4820FD](#) [CA-IF4820FS](#) [CA-IF4820HD](#) [CA-IF4820HM](#) [CA-IF4820HS](#) [CA-IF4850HS](#) [CA-IF4888HS](#) [CA-IS1200G](#) [CA-IS1200U](#) [CA-IS1204W](#) [CA-IS1300B25G](#) [CA-IS1300B25G-Q1](#) [CA-IS1300G25G](#) [CA-IS1305AM25W](#) [CA-IS1305M25W](#) [CA-IS1306AM25W](#) [CA-IS1306M25G](#) [CA-IS1306M25W](#) [CA-IS1311G](#) [CA-IS2062VW](#) [CA-IS2062W](#) [CA-IS2082B](#) [CA-IS2092A](#) [CA-IS2092VW](#) [CA-IS2092W](#)