

Features

- Low forward voltage drop, high efficiency
- Low reverse leakage current
- High peak forward surge current (I_{FSM})
- Reduced EMI
- Maximum operating T_J up to 175 °C
- Epoxy compound is flame retardant to the UL 94V-0 standard
- RoHS compliant*, Pb free and halogen free**

Applications

- Switched-Mode Power Supplies (SMPS)
- Power Factor Correction (PFC)
- PV inverters
- DC-DC converters
- Telecommunications
- Motor drives

BSDD10S65E6 Silicon Carbide Schottky Diode

General Information

Bourns® Model BSDD10S65E6 Silicon Carbide (SiC) Schottky Diode provides excellent current carrying capacity. This advanced, high efficiency power component is suitable for applications such as converters requiring a high peak forward surge capability, a very low forward voltage drop, reduced thermal resistance and low power loss.

Bourns offers Silicon Carbide Schottky Diodes for rectification applications in assorted styles. The Model BSDD10S65E6 is available in a TO252 (DPAK) package, well-suited for high frequency Switched-Mode Power Supplies.

Additional Information

Click these links for more information:



Absolute Maximum Ratings (@ $T_J = 25\text{ °C}$ Unless Otherwise Noted)

Parameter	Symbol	BSDD10S65E6	Unit
Repetitive Peak Reverse Voltage	V_{RRM}	650	V
Average Forward Current (Square Wave Pulse, $D = 0.5$, $T_{mb} \leq 156\text{ °C}$, Fig. Zth(j-mb))	$I_{F(AV)}$	10	A
Repetitive Peak Forward Current (Square Wave Pulse, $D = 0.5$, $T_{mb} \leq 156\text{ °C}$, $t_p = 25\text{ }\mu\text{s}$, Fig. Zth(j-mb))	I_{FRM}	20	A
Non-Repetitive Peak Forward Surge Current (10 ms, Single Sine-Wave Pulse)	I_{FSM}	80	A
Total Power Dissipation	P_{tot}	138.8	W
Operating Junction Temperature Range	T_J	-55 to +175	°C
Storage Temperature	T_{STG}	-55 to +175	°C

Thermal Characteristics

Parameter	Symbol	Condition or Model	Min.	Typ.	Max.	Unit
Thermal Resistance	Junction to Ambient	$R_{\theta(J-A)}$	In ambient air		60	°C/W
	Junction to Mounting Base	$R_{\theta(J-mb)}$	Transient thermal impedance curves		0.83 1.08	

Electrical Characteristics (@ $T_J = 25\text{ °C}$ Unless Otherwise Noted)

Parameter	Symbol	Condition or Model	Min.	Typ.	Max.	Unit
Forward Voltage	V_F	$I_F = 10\text{ A}$, $T_J = 25\text{ °C}$ $I_F = 10\text{ A}$, $T_J = 175\text{ °C}$		1.29 1.5	1.45 1.7	V
Reverse Leakage Current	I_R	$V_R = 650\text{ V}$, $T_J = 25\text{ °C}$ $V_R = 650\text{ V}$, $T_J = 175\text{ °C}$		1 15	50 200	μA
Recovered Charge	Q_r	$di_F/dt = 500\text{ A}/\mu\text{s}$, $V_R = 400\text{ V}$, $I_F = 10\text{ A}$		24		nC
Diode Capacitance	C_d	$V_R = 1\text{ V}$, $f = 1\text{ MHz}$		500		pF
Capacitance Stored Energy	E_c	$V_R = 400\text{ V}$		5.2		μJ



WARNING Cancer and Reproductive Harm - www.P65Warnings.ca.gov

*RoHS Directive 2015/863, Mar 31, 2015 and Annex.

**Bourns considers a product to be "halogen free" if (a) the Bromine (Br) content is 900 ppm or less; (b) the Chlorine (Cl) content is 900 ppm or less; and (c) the total Bromine (Br) and Chlorine (Cl) content is 1500 ppm or less.

Specifications are subject to change without notice.

Users should verify actual device performance in their specific applications.

The products described herein and this document are subject to specific legal disclaimers as set forth on the last page of this document, and at www.bourns.com/docs/legal/disclaimer.pdf.

BSDD10S65E6 Silicon Carbide Schottky Diode



Rating and Characteristic Curves ($T_J = 25\text{ }^\circ\text{C}$ unless otherwise noted)

Typical Forward Characteristics

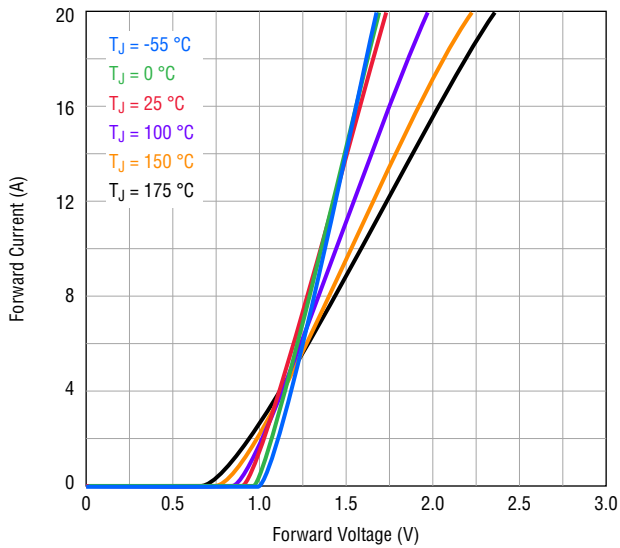

Typical Reverse Characteristics

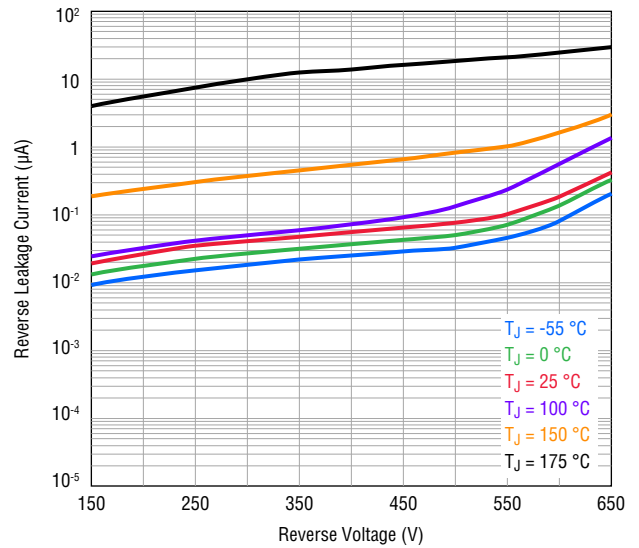

Forward Power Dissipation

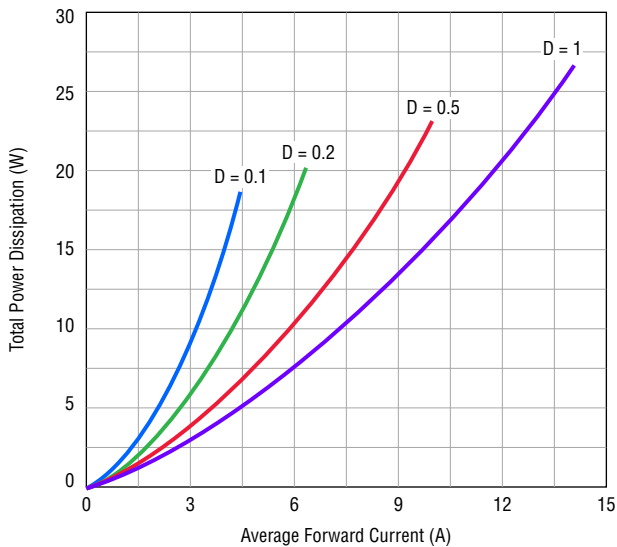

Forward Current Derating

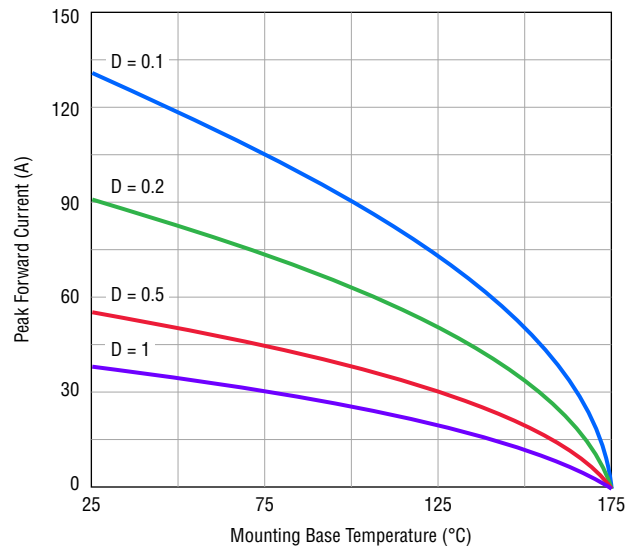

Specifications are subject to change without notice.

Users should verify actual device performance in their specific applications.

The products described herein and this document are subject to specific legal disclaimers as set forth on the last page of this document, and at www.bourns.com/docs/legal/disclaimer.pdf.

BSDD10S65E6 Silicon Carbide Schottky Diode



Rating and Characteristic Curves (Continued)

Power Derating

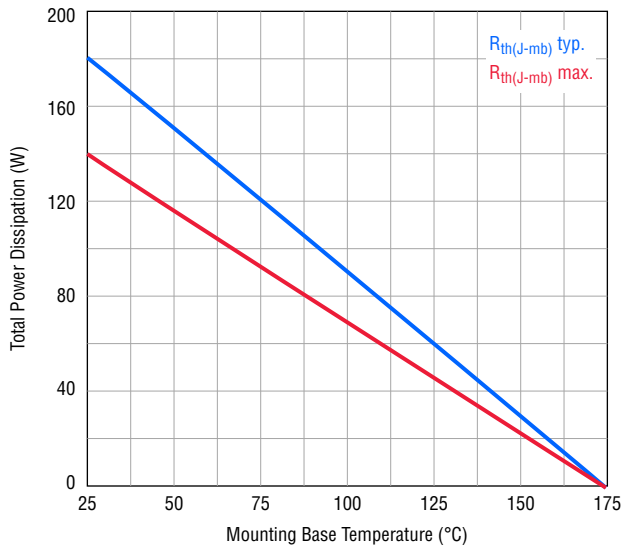

Typical Recovered Charge vs V_R

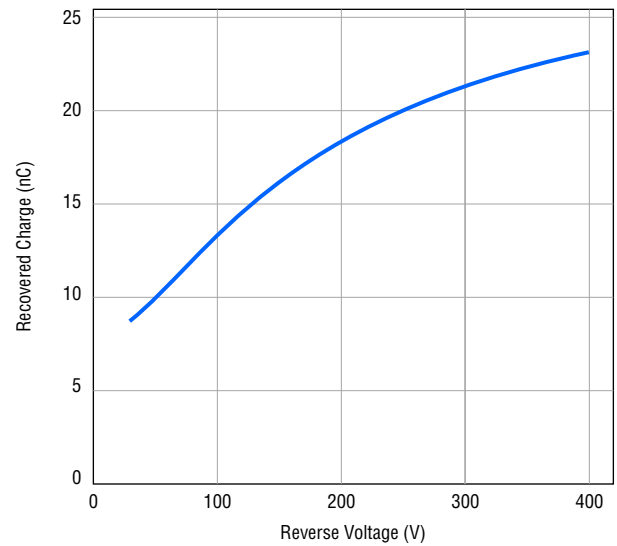

Typical Diode Capacitance vs V_R

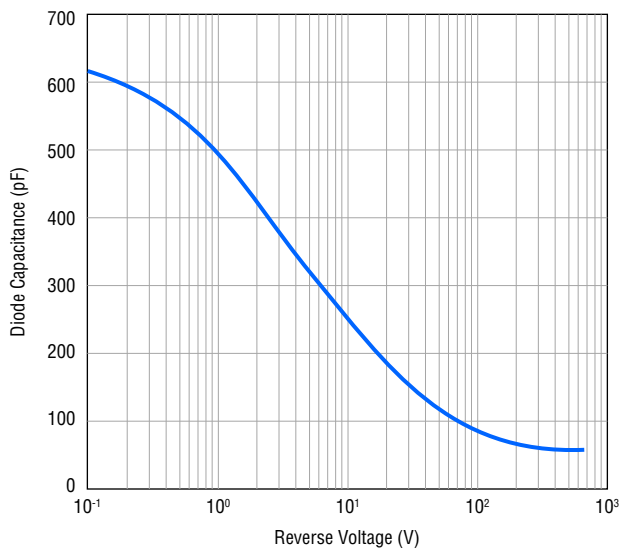

Typical Capacitance Stored Energy vs V_R

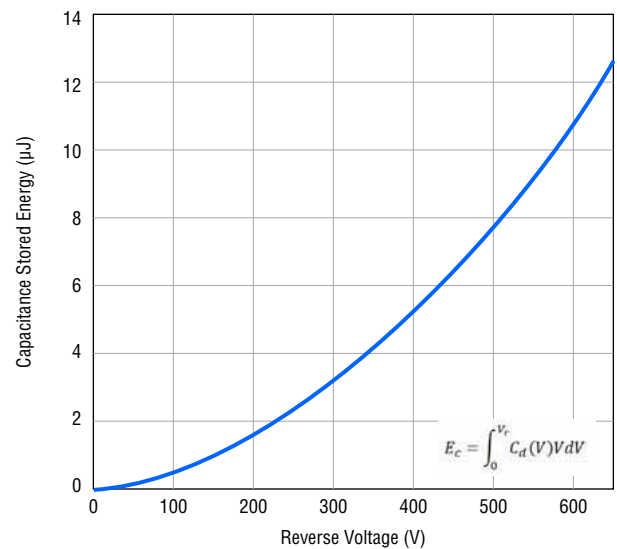

Specifications are subject to change without notice.

Users should verify actual device performance in their specific applications.

The products described herein and this document are subject to specific legal disclaimers as set forth on the last page of this document, and at www.bourns.com/docs/legal/disclaimer.pdf.

BSDD10S65E6 Silicon Carbide Schottky Diode

BOURNS®

Transient Thermal Impedance, $Z_{th(J-mb)}$

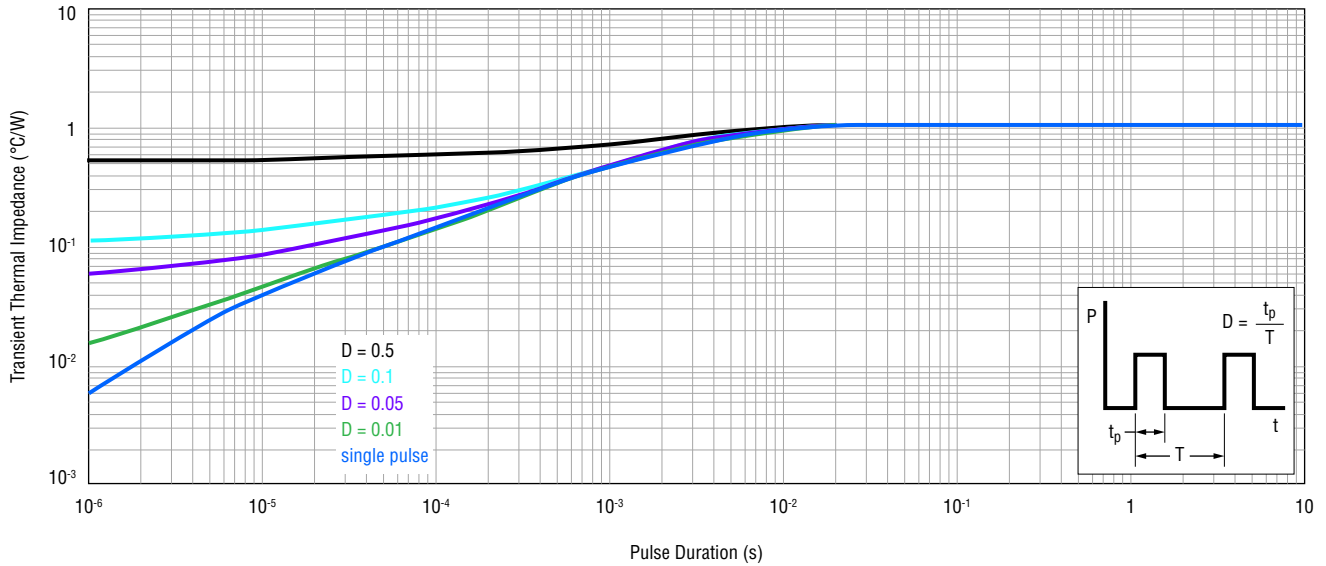

Product Dimensions

Package: TO252 (DPAK)

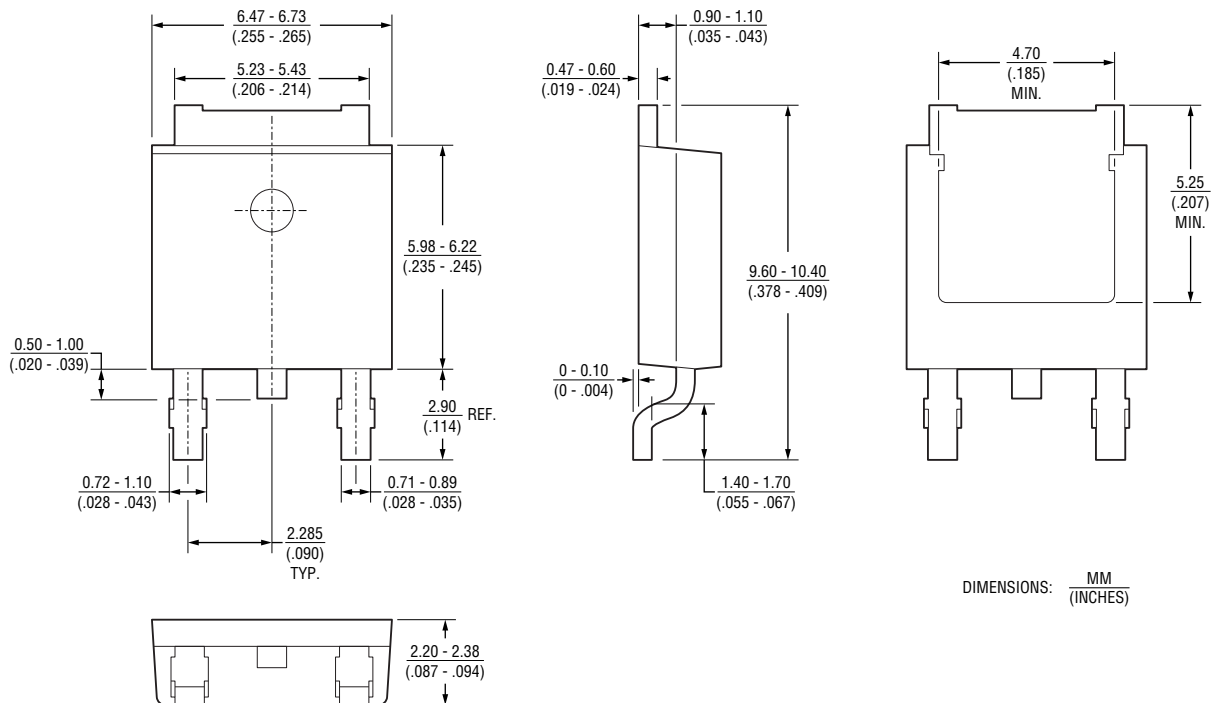

Specifications are subject to change without notice.

Users should verify actual device performance in their specific applications.

The products described herein and this document are subject to specific legal disclaimers as set forth on the last page of this document, and at www.bourns.com/docs/legal/disclaimer.pdf.

BSDD10S65E6 Silicon Carbide Schottky Diode



Typical Part Marking

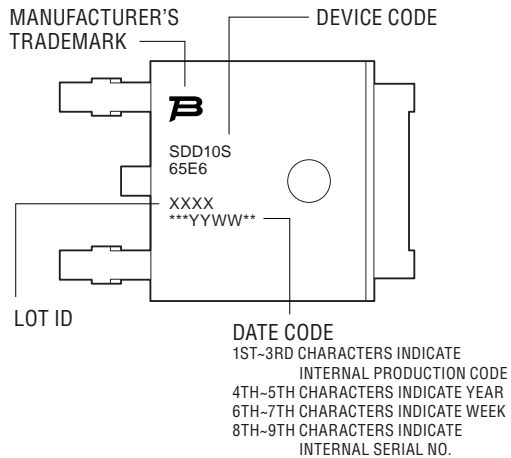

Environmental Specifications

ESD Classification (HBM).....3B

How to Order

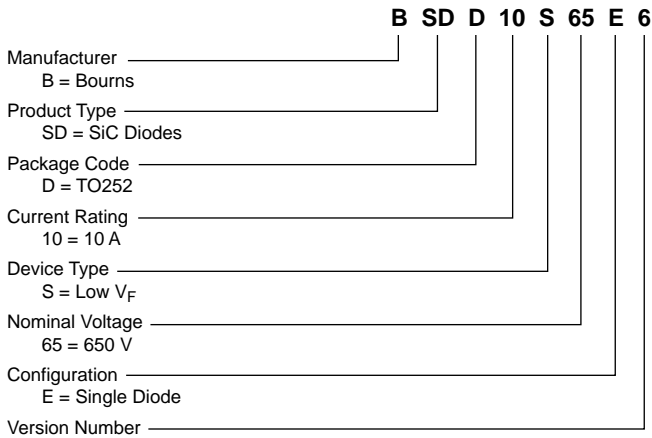

Pin Information

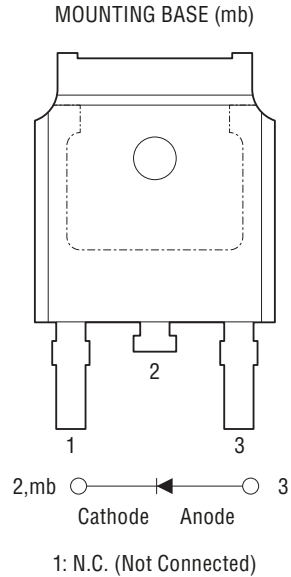

Recommended Footprint

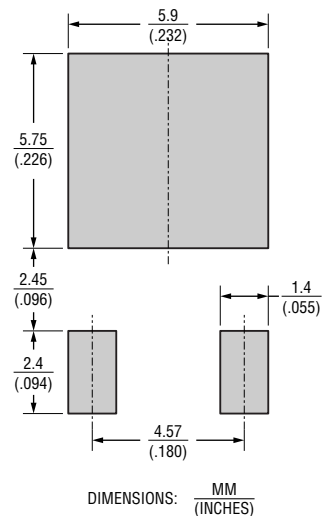

Specifications are subject to change without notice.

Users should verify actual device performance in their specific applications.

The products described herein and this document are subject to specific legal disclaimers as set forth on the last page of this document, and at www.bourns.com/docs/legal/disclaimer.pdf.

BSDD10S65E6 Silicon Carbide Schottky Diode

BOURNS®

Packaging Specifications

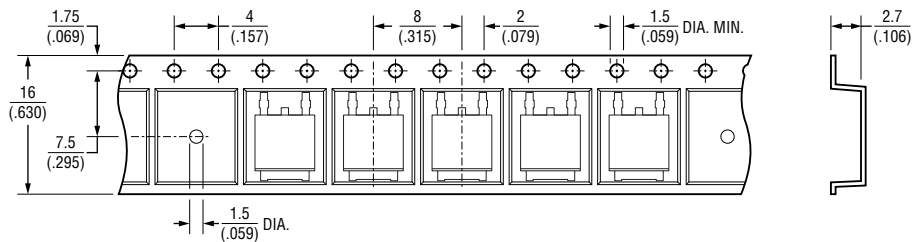
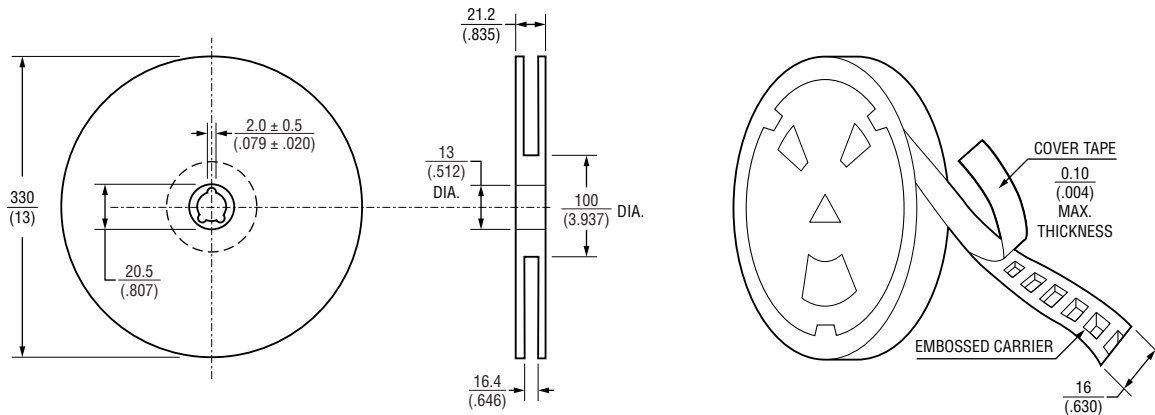

DIMENSIONS: $\frac{\text{MM}}{\text{(INCHES)}}$

USER DIRECTION OF FEED \rightarrow
QTY: 2,500 PCS PER REEL

BOURNS®

Asia-Pacific: Tel: +886-2 2562-4117

Email: asiacus@bourns.com

EMEA: Tel: +36 88 885 877

Email: euocus@bourns.com

The Americas: Tel: +1-951 781-5500

Email: americus@bourns.com

www.bourns.com

REV. 08/23

Specifications are subject to change without notice.

Users should verify actual device performance in their specific applications.

The products described herein and this document are subject to specific legal disclaimers as set forth on the last page of this document, and at www.bourns.com/docs/legal/disclaimer.pdf.

X-ON Electronics

Largest Supplier of Electrical and Electronic Components

Click to view similar products for [SiC Schottky Diodes](#) category:

Click to view products by [Bourns](#) manufacturer:

Other Similar products are found below :

[C3D02060F](#) [C3D04065E](#) [C3D10060G](#) [C4D02120A](#) [C4D20120D](#) [C3D03060A](#) [C3D04060A](#) [C3D08065A](#) [C3D10060A](#) [C3D10065A](#)
[C3D16060D](#) [C4D10120D](#) [C3D08065I](#) [C3D20065D](#) [C4D10120A](#) [C4D15120A](#) [C4D20120A](#) [C4D30120D](#) [C4D40120D](#) [BSDB10S65E6](#)
[BSDD10G65E2](#) [BSDD10S65E6](#) [BSDH06G65E2](#) [BSDH08G65E2](#) [BSDH10S65E6](#) [DSC04A065LP-13](#) [DSC04C065LP-13](#) [DSC06A065LP-13](#)
[DSC08A065LP-13](#) [DSC10A065LP-13](#) [SI20C065D2](#) [SI20C065CD2](#) [SICW20C065](#) [GD60MPS17H](#) [GD25MPS17H](#) [GD30MPS12H](#)
[GD50MPS12H](#) [GD05MPS17H](#) [GD02MPS12E](#) [GD10MPS12A](#) [GD2X75MPS17N](#) [GE04MPS06A](#) [GD10MPS12E](#) [GE04MPS06E-TR](#)
[GE06MPS06E-TR](#) [GE08MPS06E-TR](#) [GE10MPS06E-TR](#) [GE12MPS06A](#) [GE12MPS06E-TR](#) [GE04MPS06Q-TR](#)