

Amphenol® Amphe-Lite™ Subminiature Cylindrical Connectors

12-094-2

Commercial 38999 Series III Type Connectors
with contacts available in signal, power, coax and fiber optics.

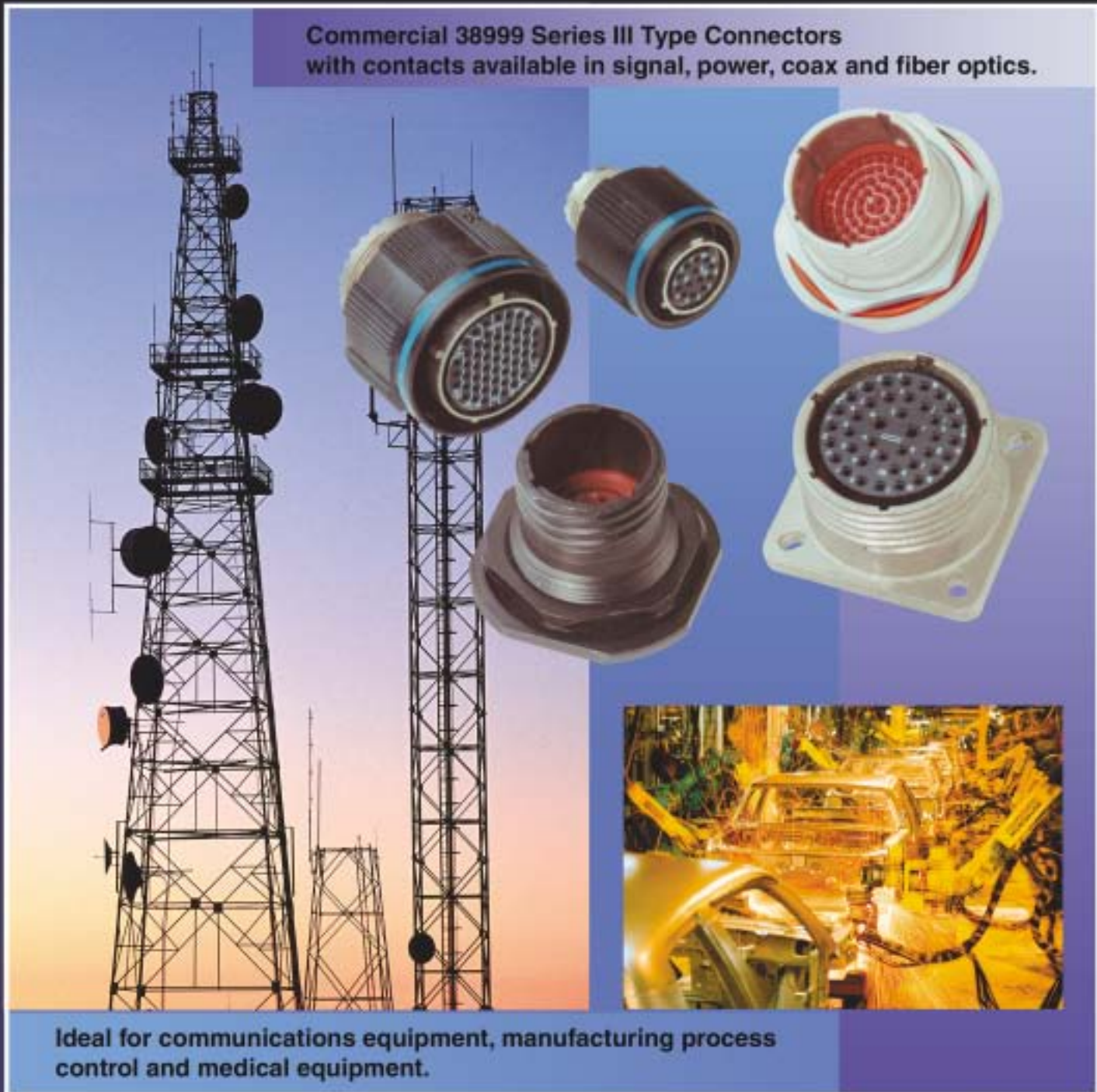

Amphenol

Table of Contents	Page No.
Amphe-Lite* Series - Amphenol's Ultimate Commercial Subminiature Connector	1
Performance Criteria, Specifications	2
Insert Availability and Identification	3
Alternate Positioning	4
Insert Arrangements	5 - 8
Shell Styles	
AL00 Wall Mounting Receptacle	9
AL06 Straight Plug	10
AL07 Jam Nut Receptacle	11
Accessories	
Receptacle Protection Cap	12
Plug Protection Cap	13
Dummy Receptacle	14
Cable Clamps	15
Contacts, Sealing Plugs, Plastic Dust Caps	16
Contacts (Printed Circuit Board, Wire wrap)	17
Fiber Optic Termini	18 - 20
Application Tools	21
How to Order Amphe-Lite Connectors	22
Amphe-Lite Capabilities (Fiber Optics, Filter Contacts, Flex Terminations, Coax Contacts)	23
Amphe-Lite Capabilities (Ground Plane Connectors, Power Contacts, Twinax Contacts).	24
 Sales Office Listing	

Please visit our Website at www.amphenol-industrial.com

Also visit www.amphenol-aerospace.com. Amphenol Industrial Operations and Amphenol Aerospace are both located at Sidney, NY. Together with other Amphenol divisions worldwide, Amphenol offers one of the broadest ranges of interconnect products in the marketplace.

Amphenol Aerospace and Amphenol Industrial Operations are Certified ISO 9001 Manufacturers.

* Amphe-Lite is a registered trademark of Amphenol Corporation.

Amphe-Lite Series

Amphenol's ultimate commercial subminiature connector

Commercial 38999, Series III Type Composite Connectors

The Amphe-Lite Connector Series is designed for communications equipment manufacturers with signal, power, RF or fiber optic interconnect requirements in harsh environments such as communication towers, outdoor and roof-top applications. This commercial 38999, Series III type composite connector series is ideal for communications equipment, manufacturing process control and medical equipment.

The Amphe-Lite offers the highest performance capabilities for severe environment applications, and yet is cost effective enough for general duty and non-environmental applications.

The Amphe-Lite is UL Recognized, file E115497.

Features and Benefits of the Amphe-Lite Series:

- Service Class F Amphe-Lite connectors provide excellent EMI shielding and grounding through electroless nickel plating and spring grounding rings. Environmental sealing is ensured with interfacial seals to prevent contact corrosion. Composite shells are completely immune to corrosion problems.
- Service Class U provides a non-conductive finish when EMI shielding is not a criteria.
- Class F Composite shells resist severe corrosion, and provide plating endurance from salt spray exposure for a minimum of 2000 hours.
- Completely mates in one 360-degree turn of the coupling nut to provide the fastest and easiest equipment assembly and maintenance possible.
- Acme threads provide coupling durability. Thicker wall sections and a greater coupling surface area improve strength and shock resistance. Blunting of the thread on both the coupling nut and receptacle eliminates cross coupling.
- Recessed pins minimize potential contact damage in this 100% scoop-proof connector. In a blind mating application, mating shells cannot "scoop" the pins and cause a shorting or bending of contacts.
- A rigid dielectric insert with excellent electrical characteristics provides durable protection to the contacts. The socket contacts are probe proof, and all contacts are rear insertable and rear removable. Available in sizes 10 power, 12, 16, 20 and 22D contacts are plated in the standard 50 micro inches minimum gold, with 100 micro inches as an option.

Optional Features:

- Conductive and non-conductive finish options are available. See how to order pg. 22.
- Circuit protection with filter contacts or surge arresting devices are available. See pg. 23.
- Fiber optics, extended life and shielded coaxial contacts can be specified in Amphe-Lite connectors. See pg. 23.
- Ground plane versions of the Amphe-Lite can be specified for use with coaxial and triaxial contacts. Twinax and power contacts can also be specified in the Amphe-Lite. See pg. 24.
- Selectively plated contacts are available. See pg. 16.
- High decoupling option is available for high vibration applications. See how to order pg. 22.

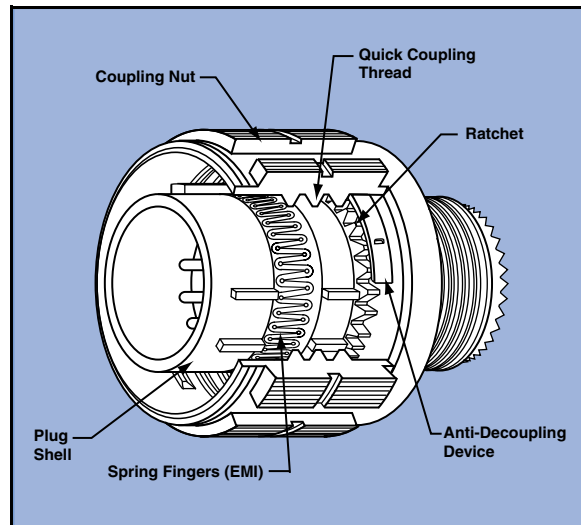

Designed for Performance

Numerous advantages in performance capability are designed into the Amphenol® Amphe-Lite Connector. A positive shoulder to shoulder coupling design, grounding fingers, and electroless nickel plating provide superior EMI shielding capability of 65 dB minimum at 10 GHz.

Amphe-Lite Shell Styles



wall mount receptacle



straight plug



jam nut receptacle

Amphe-Lite Series

performance criteria, specifications

Amphenol® Amphe-Lite connectors provide EMI shielding capability which exceeds MIL-DTL-38999 Series III requirements.

The Amphe-Lite connector with EMI grounding fingers and conductive finishes has proven to be the ultimate in EMI shielding effectiveness. The charts at right illustrate shielding effectiveness data which is typical of connectors tested with the nickel finish over a wide frequency range.

These capabilities along with a 125°C temperature rating and superior moisture sealing protection provide the user with a connector that can withstand the most rigorous application. UL RTI rating is 105°C

CONTACT RATING

Contact Size	Test Current		Maximum Millivolt Drop Crimp*
	Crimp	Hermetic	
22D	5	3	73
20	7.5	5	55
16	13	10	49
12	23	17	42
10 (Power)	33	NA	33

* When using silver plated wire.

Contact Size	Crimp Well Data	
	Well Diameter	Nominal Well Depth
22D	.0345 ±.0010	.141
20	.047 ±.001	.209
16	.067 ±.001	.209
12	.100 ±.002	.209
10 (Power)	.137 ±.002	.355

SERVICE RATING

Service Rating	Suggested Operating Voltage (Sea Level)		Test Voltage (Sea Level)
	AC (RMS)	DC	
M	400	550	1300 VRMS
N	300	450	1000 VRMS
I	600	850	1800 VRMS
II	900	1250	2300 VRMS

** Please note that the establishment of electrical factors is left entirely in the designers hands, since he is in the best position to know what voltage, switching surges, transients, etc. can be expected in a particular circuit.

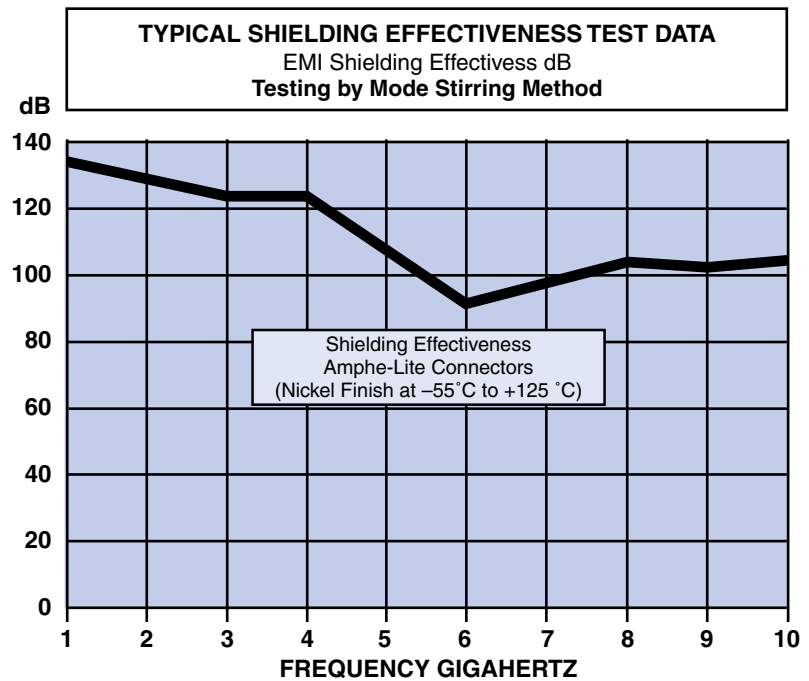
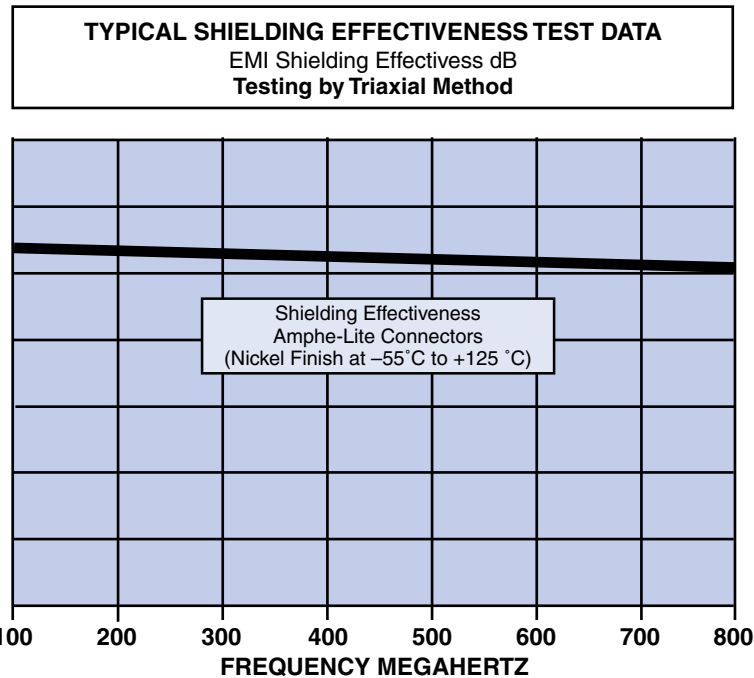

Test data beyond 2GHz is subject to equipment variation.

FINISH DATA

Amphe-lite connectors are available in the following finishes:

- Conductive Electroless Nickel Plated Composite (Service Class F)
- Black Composite, unplated (Service Class U)
- Conductive Black Zinc Composite (Service Class X)

See how to order page 22.

Amphe-Lite Series

insert availability and identification

Shell Size/Arrg.	Service Rating	Total Contacts	Contact Size							
			22D	20	16	12	12 (Coax)	10 (Power)	8 (Coax)	8†† (Twinax)
9-5★	Grounded	1								1
9-35	M	6	6							
9-94	M	2		2						
9-98	I	3		3						
11-2★	I	2			2					
11-5	I	5		5						
11-35	M	13	13							
11-98	I	6		6						
11-99	I	7		7						
13-4★	I	4			4					
13-8	I	8		8						
13-35	M	22	22							
13-98	I	10		10						
15-5★	II	5			5					
15-15	I	15		14	1					
15-18	I	18		18						
15-19	I	19		19						
15-35	M	37	37							
15-97	I	12		8	4					
15-AC	M	26	24		2					
17-2	M	39	38							1
17-6	I	6				6				
17-8★	II	8			8					
17-22★	NA	4					2		2	
17-26	I	26		26						
17-31	M	19	4	11	4					
17-35	M	55	55							
17-99	I	23		21	2					
19-11★	II	11			11					
19-31	M	15	12			1			2	
19-32	I	32		32						
19-35	M	66	66							
21-11★	I	11				11				
21-16★	II	16			16					
21-35	M	79	79							
21-39	I	39		37	2					
21-41	I	41		41						
21-75★	M	4								(See Note)
23-6★	M	6								6
23-21★	II	21			21					
23-35	M	100	100							
23-53	I	53		53						
23-54	M	53	40		9	4				
23-55	I	55		55						
25-4	I	56		48	8					
25-7	NA	99	97							2
25-8★	NA	8								8
25-11	N	11		2				9		
25-17	M	42	36							6
25-19★	I	19				19				
25-20	N	30		10	13*		4			3
25-24★	I	24			12	12				
25-26	I	25		16		5			4	
25-29★	I	29			29					
25-35	M	128	128							
25-37★	I	37			37					
25-43	I	43		23	20					
25-46	I	46		40	4				2†	
25-61	I	61		61						

★ Ground plane proprietary option available. Arrg. 9-5 is exclusively ground plane type. See page 24 for further information of ground plane connectors.

* Two size 16 contacts dedicated to fiber optics. Consult Sidney, NY or catalog 12-352 for fiber optic information.

† For RG180/U and RG195/U cables only. (Contact Sidney, NY for other cable application).

†† Size 8 Coax and Twinax are interchangeable.

Amphe-Lite Series

alternate insert positioning

MASTER KEY/KEYWAY POSITION

Shell Size	Key & keyway arrangement identification letter	AR° or AP° BSC	BR° or BP° BSC	CR° or CP° BSC	DR° or DP° BSC
9	N	105	140	215	265
	A	102	132	248	320
	B	80	118	230	312
	C	35	140	205	275
	D	64	155	234	304
11, 13, and 15	N	95	141	208	236
	A	113	156	182	292
	B	90	145	195	252
	C	53	156	220	255
	D	119	146	176	298
17 and 19	N	80	142	196	293
	A	135	170	200	310
	B	49	169	200	244
	C	66	140	200	257
	D	62	145	180	280
21, 23, and 25	N	80	142	196	293
	A	135	170	200	310
	B	49	169	200	244
	C	66	140	200	257
	D	62	145	180	280
21, 23, and 25	E	79	153	197	272

A plug with a given rotation letter will mate with a receptacle with the same rotation letter. The angles for a given connector are the same whether it contains pins or sockets. Inserts are not rotated in conjunction with the master key/keyway.

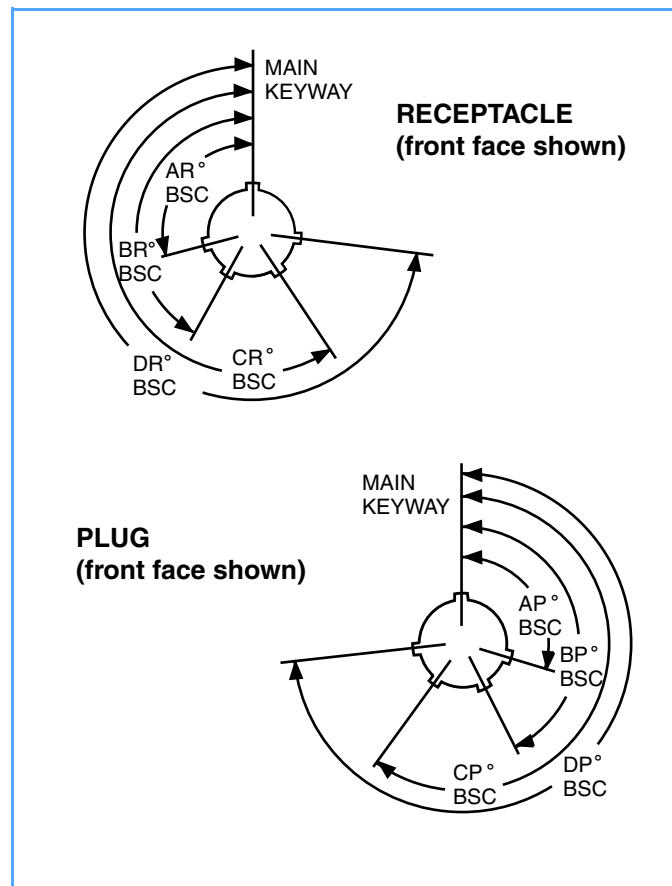

Amphe-Lite Series

insert arrangements

front face of pin inserts illustrated

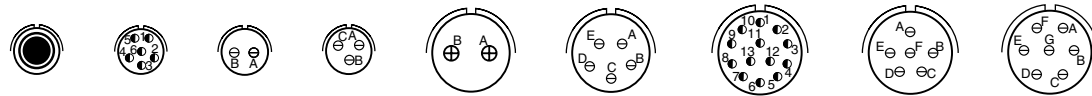

Insert Arrangement	9-5	9-35	9-94	9-98	11-2	11-5	11-35	11-98	11-99
Service Rating	Grounded	M	M	I	I	I	M	I	I
Number of Contact	1	6	2	3	2	5	13	6	7
Contact Size	8 Twinax	22D	20	20	16	20	22D	20	20

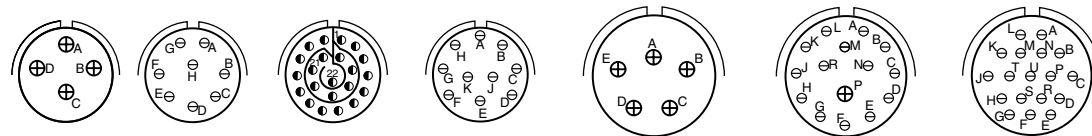

Insert Arrangement	13-4	13-8	13-35	13-98	15-5	15-15	15-18
Service Rating	I	I	I	M	I	II	I
Number of Contacts	4	8	22	10	5	14	1
Contact Size	16	20	22D	20	16	20	16

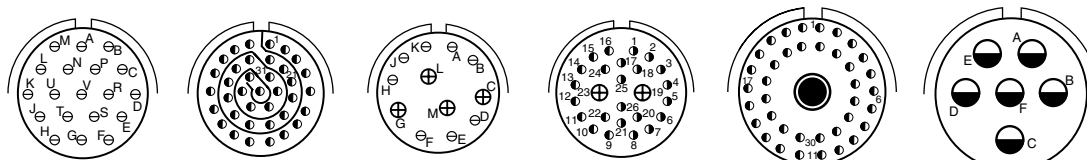

Insert Arrangement	15-19	15-35	15-97	15-AC	17-2	17-6
Service Rating	I	M	I	M	M	I
Number of Contacts	19	37	8	4	24	2
Contact Size	20	22D	20	16	22D	16

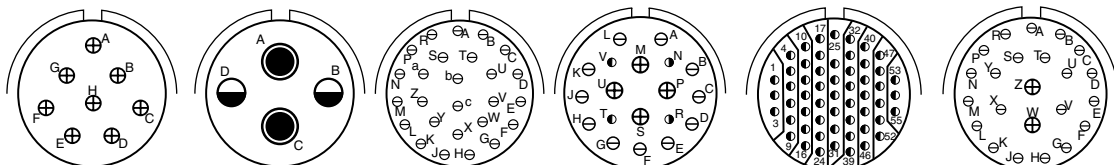

Insert Arrangement	17-8	17-22	17-26	17-31	17-35	17-99
Service Rating	II	Coax	I	M	M	I
Number of Contacts	8	2	2	26	4	11
Contact Size	16	12 Coax	8 Coax	20	22D	20



Amphe-Lite Series

insert arrangements

front face of pin inserts illustrated

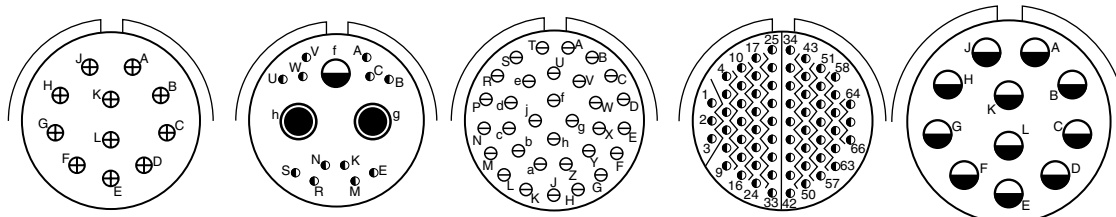

Insert Arrangement	19-11	19-31		19-32		19-35		21-11	
Service Rating	II	M		I		M		I	
Number of Contacts	11	2	1	12	32	66		11	
Contact Size	16	8 Coax	12	22D	20	22D		12	

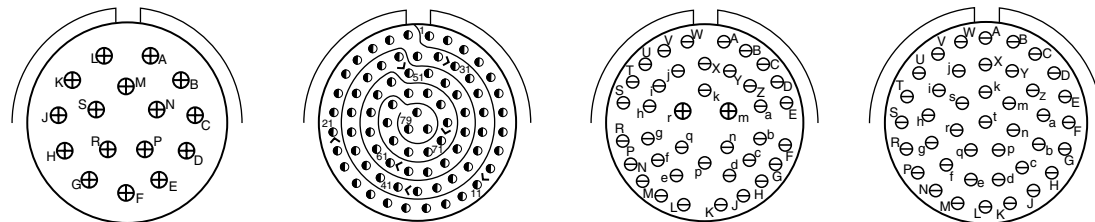

Insert Arrangement	21-16	21-35		21-39		21-41	
Service Rating	II	M		I		I	
Number of Contacts	16	79	37	2	41		
Contact Size	16	22D	20	16	20		

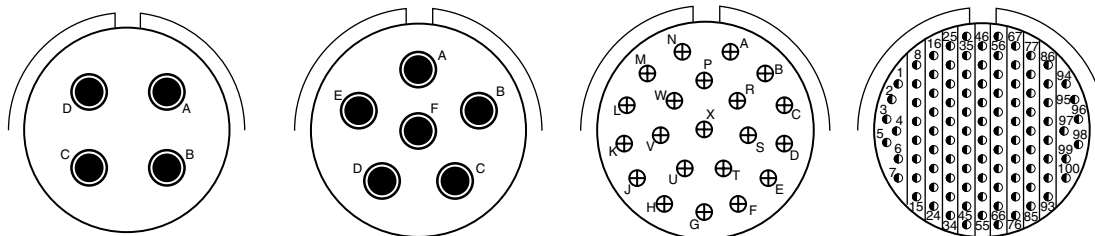

Insert Arrangement	21-75	23-6	23-21	23-35
Service Rating	M	M	II	M
Number of Contacts	4	6	21	100
Contact Size	8 Coax	8 Twinax	16	22D

Note: Size 8 cavities can be supplied with either twinax or coax per customer requirement.



Amphe-Lite Series

insert arrangements

front face of pin inserts illustrated

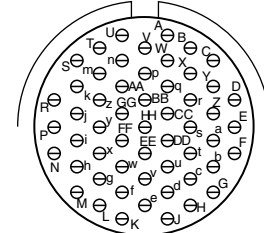
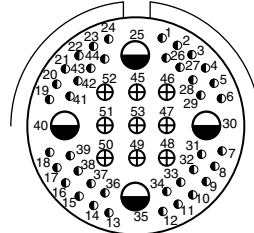
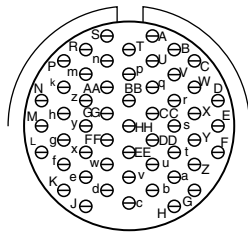

Insert Arrangement
Service Rating
Number of Contacts
Contact Size

23-53
I
53
20

23-54
M
40 9 4
22D 16 12

23-55
I
55
20

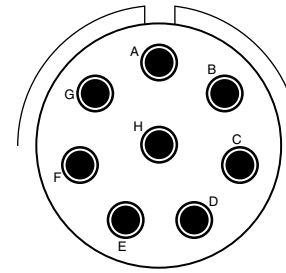
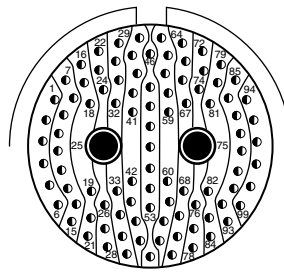
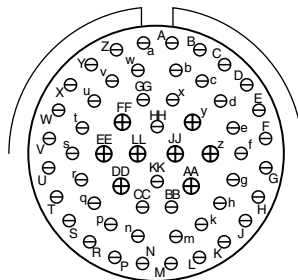

Insert Arrangement
Service Rating
Number of Contacts
Contact Size

25-4
I
48 8
20 16

25-7
NA
97 2
22D 8 Twinax

25-8
NA
8
8 Twinax

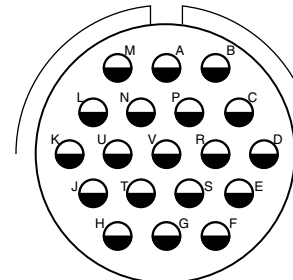
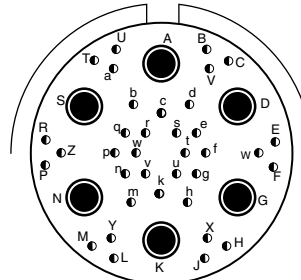
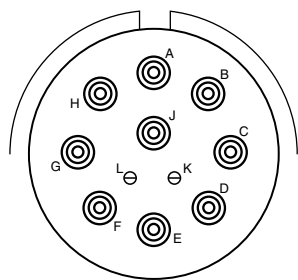

Insert Arrangement
Service Rating
Number of Contacts
Contact Size

25-11
N
2 9
20 10 Power

25-17
M
36 6
22D 8 Twinax

25-19
I
19
12



Amphe-Lite Series

insert arrangements

front face of pin inserts illustrated

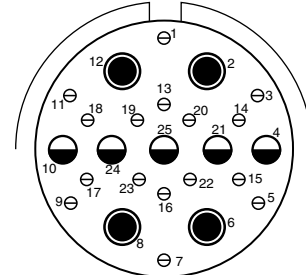
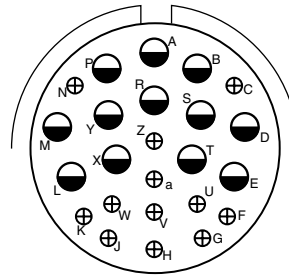
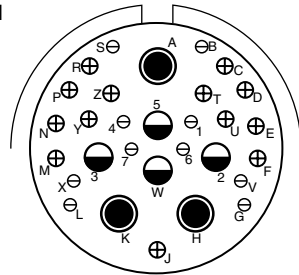

Insert Arrangement	25-20				25-24		25-26		
Service Rating	N				I		I		
Number of Contacts	10	13	3	4	12	12	16	5	4
Contact Size	20	16	8 Twinax	12 Coax	16	12	20	12	8 Coax

(Locations U and Y - Dedicated to Fiber Optics)

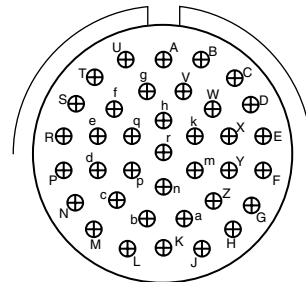
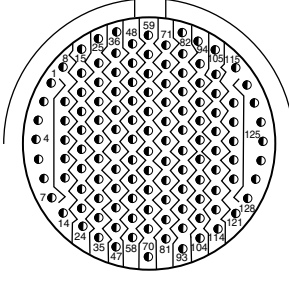
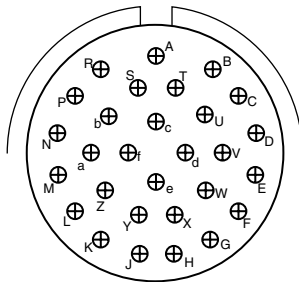

Insert Arrangement	25-29		25-35		25-37	
Service Rating	I		M		I	
Number of Contacts	29		128		37	
Contact Size	16		22D		16	

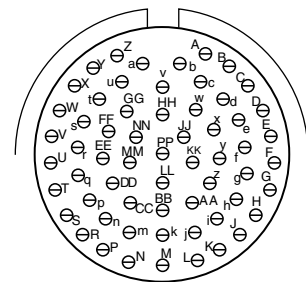
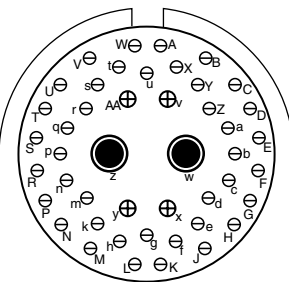
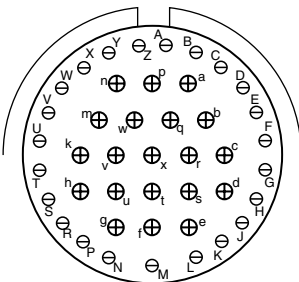

Insert Arrangement	25-43		25-46			25-61	
Service Rating	I		I			I	
Number of Contacts	23	20	40	4	2	61	
Contact Size	20	16	20	16	8 Coax†	20	

† Coax contacts for RG180 or RG195 cable.



Amphe-Lite Series

AL00 wall mounting receptacle, composite

AL00F()*
 AL00U()*
 AL00X()*

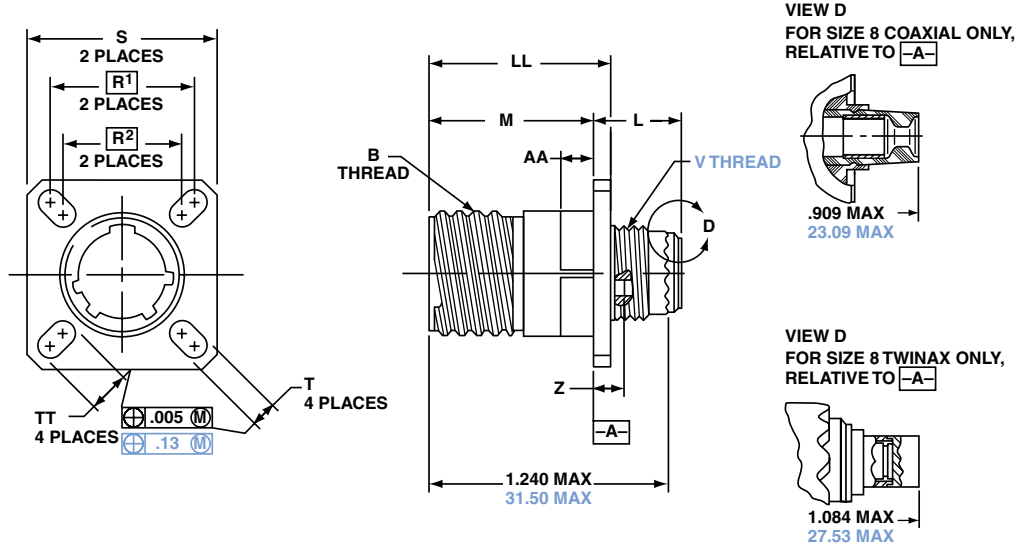

* To complete order number, see page 22.

Inches

Shell Size	B Thread Class 2A 0.1P-0.3L-TS (Plated)	L Max.	M +.000 - .005	R¹	R²	S Max.	T +.008 - .006	Z Max.	AA Max. Panel Thickness	LL ±.005	TT +.008 - .006
9	.6250	.514	.775	.719	.594	.948	.128	.198	.234	.913	.216
11	.7500	.514	.775	.812	.719	1.043	.128	.198	.234	.913	.194
13	.8750	.514	.775	.906	.812	1.137	.128	.198	.234	.913	.194
15	1.0000	.514	.775	.969	.906	1.232	.128	.198	.234	.913	.173
17	1.1875	.514	.775	1.062	.969	1.323	.128	.198	.234	.913	.194
19	1.2500	.514	.775	1.156	1.062	1.449	.128	.198	.234	.913	.194
21	1.3750	.545	.745	1.250	1.156	1.575	.128	.228	.204	.911	.194
23	1.5000	.545	.745	1.375	1.250	1.701	.154	.228	.204	.911	.242
25	1.6250	.545	.745	1.500	1.375	1.823	.154	.228	.204	.911	.242

Millimeters

Shell Size	L Max.	M +.00 - .13	R¹	R²	S Max.	T +.20 - .13	V Thread Metric	Z Max.	AA Max.	LL ±.13	TT +.20 - .13
9	13.06	19.69	18.26	15.09	24.1	3.25	M12X1-6g	5.03	5.94	23.19	5.49
11	13.06	19.69	20.62	18.26	26.5	3.25	M15X1-6g	5.03	5.94	23.19	4.93
13	13.06	19.69	23.01	20.62	28.9	3.25	M18X1-6g	5.03	5.94	23.19	4.93
15	13.06	19.69	24.61	23.01	31.3	3.25	M22X1-6g	5.03	5.94	23.19	4.39
17	13.06	19.69	26.97	24.61	33.7	3.25	M25X1-6g	5.03	5.94	23.19	4.93
19	13.06	19.69	29.36	26.97	36.9	3.25	M28X1-6g	5.03	5.94	23.19	4.93
21	13.84	18.92	31.75	29.36	40.1	3.25	M31X1-6g	5.79	5.18	23.14	4.93
23	13.84	18.92	34.93	31.75	43.3	3.91	M34X1-6g	5.79	5.18	23.14	6.15
25	13.84	18.92	38.10	34.93	46.4	3.91	M37X1-6g	5.79	5.18	23.14	6.15

All dimensions for reference only

 Designates true position dimensioning

Amphe-Lite Series

AL06 straight plug, composite

AL06F()*
 AL06U()*
 AL06X()*

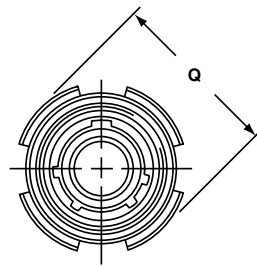
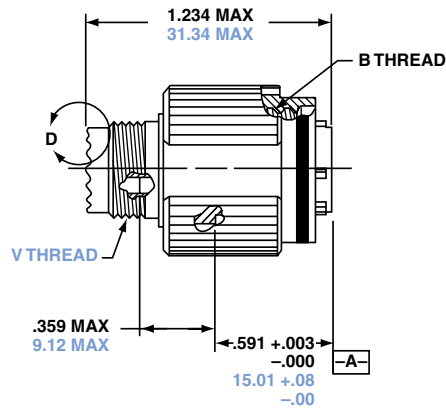

VIEW D
 FOR SIZE 8 COAXIAL ONLY,
 RELATIVE TO **-A-**

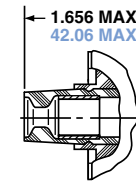

VIEW D
 FOR SIZE 8 TWINAX ONLY,
 RELATIVE TO **-A-**

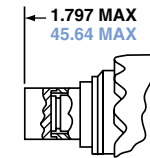

* To complete order number see page 22.

Inches		
Shell Size	B Thread 0.1P-0.3L-TS-2B (Plated)	Q Dia. Max.
9	.6250	.858
11	.7500	.984
13	.8750	1.157
15	1.0000	1.279
17	1.1875	1.405
19	1.2500	1.515
21	1.3750	1.641
23	1.5000	1.767
25	1.6250	1.889

Millimeters		
Shell Size	Q Max.	V Thread Metric
9	21.8	M12X1-6g
11	25.0	M15X1-6g
13	29.4	M18X1-6g
15	32.5	M22X1-6g
17	35.7	M25X1-6g
19	38.5	M28X1-6g
21	41.7	M31X1-6g
23	44.9	M34X1-6g
25	48.0	M37X1-6g

All dimensions for reference only.

Amphe-Lite Series

AL07 jam nut receptacle, composite

AL07F()*
 AL07U()*
 AL07X()*

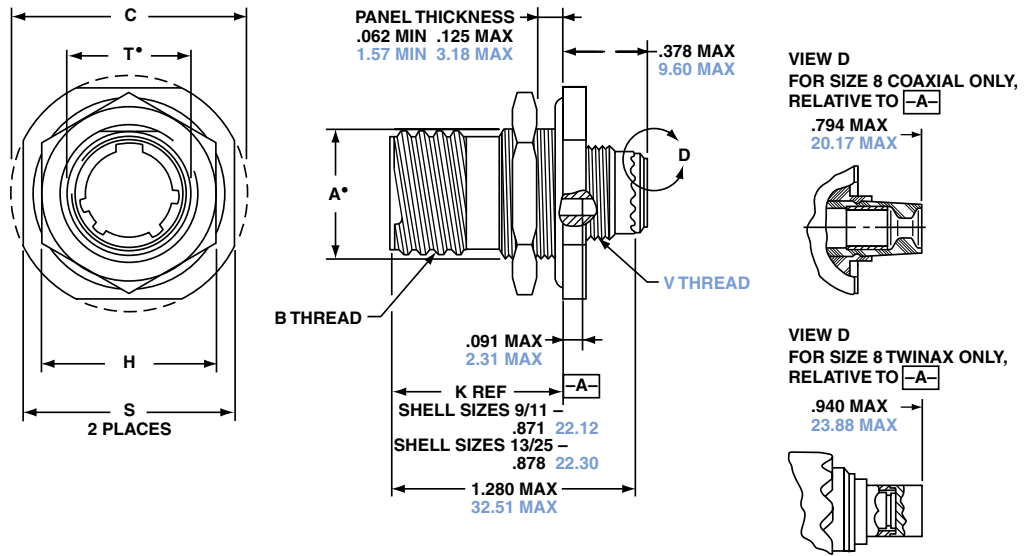

* To complete order number see page 22.

Inches

Shell Size	A* +.000 -.010	B Thread Class 2A 0.1P-0.3L-TS (Plated)	C Max.	H Hex +.017 -.016	S ±.010	T* +.010 -.000
9	.669	.6250	1.199	.875	1.062	.697
11	.769	.7500	1.386	1.062	1.250	.822
13	.955	.8750	1.511	1.250	1.375	1.007
15	1.084	1.0000	1.636	1.375	1.500	1.134
17	1.208	1.1875	1.761	1.438	1.625	1.259
19	1.333	1.2500	1.949	1.562	1.812	1.384
21	1.459	1.3750	2.073	1.688	1.938	1.507
23	1.575	1.5000	2.199	1.812	2.062	1.634
25	1.709	1.6250	2.323	2.000	2.188	1.759

Millimeters

Shell Size	A* +.00 -.25	C Max.	H Hex +.43 -.41	S ±.25	T* +.25 -.00	V Thread Metric
9	16.99	30.45	22.23	26.97	17.70	M12X1-6g
11	19.53	35.20	25.40	31.75	20.88	M15X1-6g
13	24.26	38.38	30.18	34.93	25.58	M18X1-6g
15	27.53	41.55	33.32	38.10	28.80	M22X1-6g
17	30.68	44.73	36.53	41.28	31.98	M25X1-6g
19	33.86	49.50	39.67	46.02	35.15	M28X1-6g
21	37.06	52.65	42.80	49.23	38.28	M31X1-6g
23	40.01	55.85	46.02	52.37	41.50	M34X1-6g
25	43.41	59.00	50.80	55.58	44.68	M37X1-6g

All dimensions for reference only.

- D shaped panel cut-out dimensions to prevent connector from turning

Amphe-Lite – accessories

receptacle protection cap

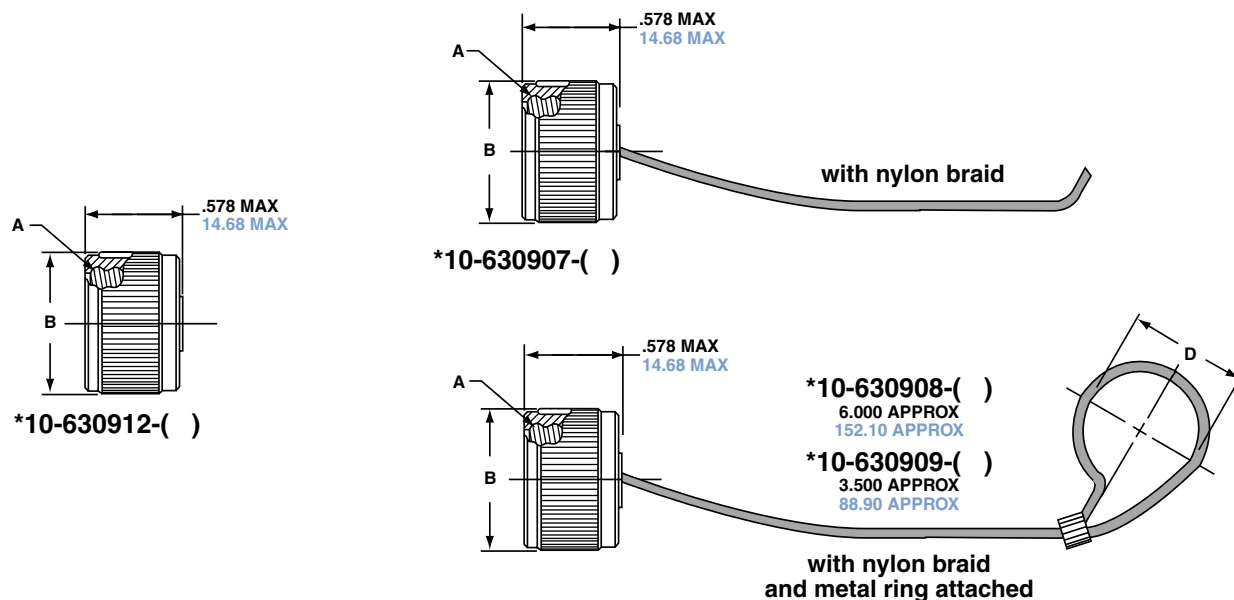

* To complete order number, add shell size and suffix number.
For example, shell size 11 with electroless nickel 10-630912-11F.

Inches

Shell Size	A Thread Class 2B 0.1P-0.3L-TS	B Dia. Max.	D Dia. +.010 -0.000
9	.6250	.875	.703
11	.7500	1.000	.844
13	.8750	1.125	1.016
15	1.0000	1.250	1.141
17	1.1875	1.438	1.266
19	1.2500	1.500	1.391
21	1.3750	1.625	1.516
23	1.5000	1.750	1.641
25	1.6250	1.875	1.766

Millimeters

Finish	10-No Suffix
Electroless nickel	-()F
Black composite, unplated	-()
Black zinc alloy, conductive	-()X

Consult Sidney, NY for availability of stainless steel protection caps.

Shell Size	B Dia. Max.	D Dia +.25 -0.00
9	22.23	17.86
11	25.40	21.44
13	28.58	25.81
15	31.75	28.98
17	36.53	32.16
19	38.10	35.33
21	41.28	38.51
23	44.45	41.68
25	47.63	44.86

All dimensions for reference only.

Amphe-Lite – accessories

plug protection cap

*10-630910-()

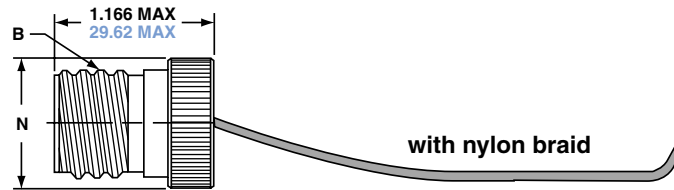

*10-630911-()

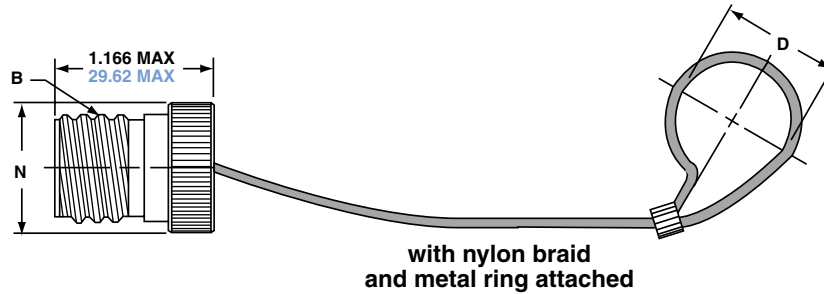

* To complete order number, add shell size and suffix number.
For example, shell size 11 with electroless nickel, 10-630910-11F

Inches

Shell Size	A Thread Class 2A 0.1P-0.3L-TS	D +.030 -.000	N Dia. Max.
9	.6250	.516	.895
11	.7500	.641	1.000
13	.8750	.766	1.171
15	1.0000	.891	1.299
17	1.1875	1.016	1.436
19	1.2500	1.141	1.543
21	1.3750	1.266	1.670
23	1.5000	1.343	1.787
25	1.6250	1.516	1.914

Millimeters

Finish	10-No Suffix
Electroless nickel	-()F
Black composite, unplated	-()
Black zinc alloy, conductive	-()X

Consult Sidney, NY for availability of stainless steel protection caps.

Shell Size	D +.25 -.00	N Dia. Max.
9	13.11	22.73
11	16.28	25.40
13	19.46	29.74
15	22.63	32.99
17	25.81	36.47
19	28.98	39.19
21	32.16	42.42
23	34.11	45.39
25	38.51	48.62

All dimensions for reference only.

Amphe-Lite – accessories

dummy receptacle

*10-630913-()

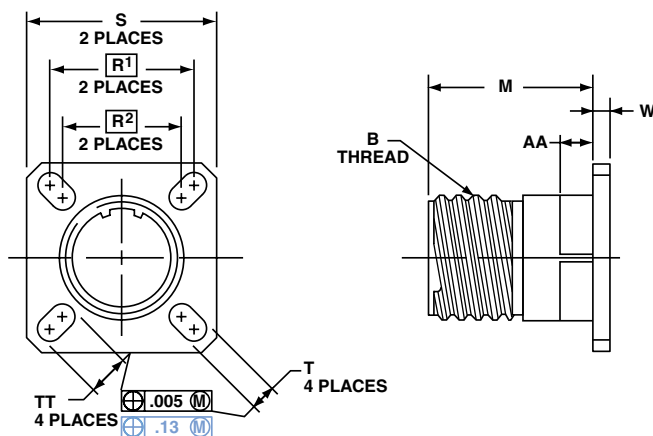

* To complete order number, add shell size and suffix number.
For example, shell size 11 with electroless nickel, 10-630913-11F.

Finish	10-No Suffix
Electroless nickel	-()F
Black composite, unplated	-()
Black zinc alloy, conductive	-()X

Inches

Shell Size	B Thread Class 2A 0.1P-0.3L-TS (Plated)	M +.020 -0.000	R ¹	R ²	S ±.010	T +.008 -0.006	W ±.010	AA Max. Panel Thickness	TT +.008 -0.006
9	.6250	.822	.719	.594	.938	.128	.098	.234	.216
11	.7500	.822	.812	.719	1.031	.128	.098	.234	.194
13	.8750	.822	.906	.812	1.125	.128	.098	.234	.194
15	1.0000	.822	.969	.906	1.219	.128	.098	.234	.173
17	1.1875	.822	1.062	.969	1.312	.128	.098	.234	.194
19	1.2500	.822	1.156	1.062	1.438	.128	.098	.234	.194
21	1.3750	.791	1.250	1.156	1.562	.128	.125	.204	1.94
23	1.5000	.791	1.375	1.250	1.688	.154	.125	.204	.242
25	1.6250	.791	1.500	1.375	1.812	.154	.125	.204	.242

Millimeters

Shell Size	M +.51 -0.00	R ¹	R ²	S ±.25	T +.20 -1.15	W ±.25	AA Max.	TT +.20 -1.15
9	20.88	18.26	15.09	23.83	3.25	2.49	5.94	5.49
11	20.88	20.62	18.26	26.19	3.25	2.49	5.94	4.93
13	20.88	23.01	20.62	28.58	3.25	2.49	5.94	4.93
15	20.88	24.61	23.01	30.96	3.25	2.49	5.94	4.39
17	20.88	26.97	24.61	33.32	3.25	2.49	5.94	4.93
19	20.88	29.36	26.97	36.53	3.25	2.49	5.94	4.93
21	20.09	31.75	29.36	39.67	3.25	3.18	5.18	4.93
23	20.09	34.93	31.75	42.88	3.91	3.18	5.18	6.15
25	20.09	38.10	34.93	46.02	3.91	3.18	5.18	6.15

All dimensions for reference only.

 Designates true position dimensioning

Amphe-Lite – accessories

cable clamps

*10-630934-XXX

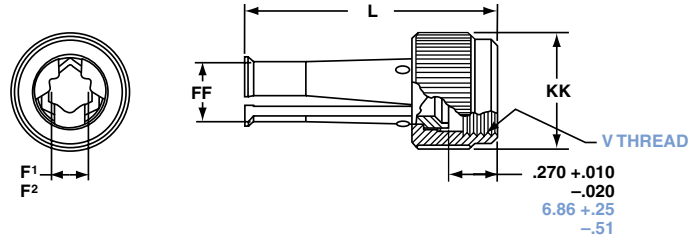

*10-630935-XXX

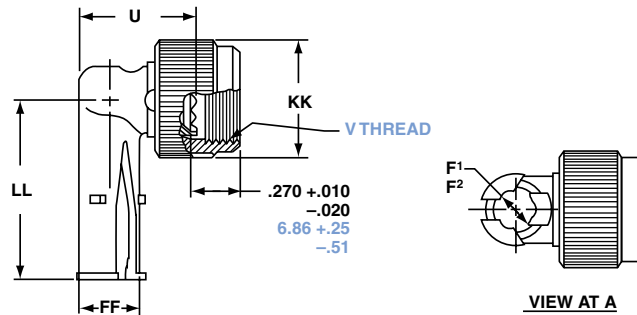

* To complete order number, add shell size and suffix number.
For example, shell size 11 with electroless nickel, 10-630934-11F.

Finish	10-No Suffix
Electroless nickel	-()F

Inches

Shell Size	F ¹ Min. Dia. Cable	F ² Max. Dia. Cable	L Max.	U Max.	FF Dia. Max.	KK Dia. Max.	LL Max.
9	.094	.203	1.431	.656	.347	.629	1.015
11	.141	.250	1.431	.688	.394	.756	1.062
13	.172	.323	1.431	.750	.467	.883	1.125
15	.203	.422	1.431	.859	.566	1.011	1.328
17	.234	.500	1.431	.937	.644	1.138	1.392
19	.265	.562	1.431	1.000	.706	1.265	1.453
21	.297	.625	1.492	1.062	.769	1.393	1.609
23	.328	.703	1.492	1.141	.847	1.488	1.656
25	.359	.765	1.492	1.203	.909	1.616	1.719

Millimeters

Shell Size	F ¹ Min. Dia. Cable	F ² Max. Dia. Cable	L Max.	U Max.	FF Dia. Max.	KK Dia. Max.	LL Max.
9	2.39	5.16	36.35	16.66	8.81	15.98	25.78
11	3.58	6.35	36.35	17.48	10.01	19.20	26.97
13	4.37	8.20	36.35	19.05	11.86	22.43	28.58
15	5.16	10.72	36.35	21.82	14.38	25.68	33.73
17	5.94	12.70	36.35	23.80	16.36	28.91	35.36
19	6.73	14.27	36.35	25.40	17.93	32.13	36.91
21	7.54	15.88	37.90	26.97	19.53	35.38	40.87
23	8.33	17.86	37.90	28.98	21.51	37.80	42.06
25	9.12	19.43	37.90	30.56	23.09	41.05	43.66

All dimensions for reference only.

Amphe-Lite Series

contacts, sealing plugs, plastic dust caps

STANDARD CONTACTS FOR AMPHE-LITE SERIES

Contact Size	Pin Part Number	Socket Part Number
8 (Coax)	21-33102-21	21-33101-21
8 (Twinax)	21-33190-529	21-33191-530
10 (Power)	10-251415-105	10-407035-105
12	10-251415-12H	10-597261-121
16	10-251415-165	10-407035-165
20	LP-251415-205	10-597261-201
22D	LP-251415-725 or 10-597434-725	10-597261-721 or 10-597825-451

Above part numbers include standard 500 cycle finish designation - gold plating over suitable underplate in accordance with MIL-C-39029.

For other contact options available for use in Amphe-Lite connectors, (thermo-couple) consult Sidney, NY.

PLASTIC DUST CAPS

Shell Size	Plug	Receptacle
9	10-70506-14	10-70500-10
11	10-70506-16	10-70500-12
13	10-70500-18	10-70500-14
15	10-70500-20	10-70500-16
17	10-70500-22	10-70500-19
19	10-70500-24	10-70500-20
21	10-70524-1	10-70500-22
23	10-70506-28	10-70500-24
25	10-70500-28	10-70524-1

For metal protection caps see pages 12 and 13.

SEALING PLUGS

Contact Size	Proprietary No.
8 (Coax)	10-482099-8
8 (Twinax)	T3-4008-59P
10 (Power)	10-576225
12	10-405996-121
16	10-405996-161
20	10-405996-201
22D	10-405996-221

Amphe-Lite Series

contacts – printed circuit board, wire wrap

SOCKETS

PCB Socket Contacts	Size	Tail Dia	Contact Stickout Max/Min (See Illustration below)		
			AL00	AL06	AL07
10-497623-15	22D	.019	.291	.316	.242
			.226	.251	.182
10-497623-25	22D	.019	.868	.893	.819
			.803	.828	.759
10-497623-35	22D	.019	.348	.373	.299
			.283	.308	.239
10-497623-45	22D	.019	.208	.233	.159
			.143	.168	.099
10-497623-75	22D	.019	.146	.171	.097
			.081	.106	.037
10-497623-105	22D	.019	.028	.053	.021
			NS	.000	NS
10-497623-145	22D	.019	.609	.634	.560
			.539	.564	.495
10-497623-155	22D	.019	.423	.448	.374
			.358	.383	.314
10-497643-15	20	.019	.348	.373	.299
			.294	.319	.250
10-497643-25	20	.019	.213	.238	.164
			.159	.184	.115
10-497643-35	20	.019	.555	.580	.506
			.501	.526	.457
10-497643-45	20	.019	.138	.163	.089
			.084	.109	.040
10-497650-15	16	.040	.255	.280	.206
			.201	.226	.157
Wire Wrap Contacts		Tail Square			
10-497577-15	22D	.025	.155	.180	.106
			.090	.115	.046
10-497577-25	22D	.025	.002	.027	NS
			NS	NS	NS
10-497577-35	22D	.025	.201	.226	.152
			.136	.161	.092
10-497577-55	22D	.025	.566	.591	.517
			.501	.526	.457
10-497621-15	20	.025	.151	.176	.102
			.101	.126	.057
10-497621-25	20	.025	.605	.630	.556
			.555	.580	.511
10-497621-35	20	.025	.308	.333	.259
			.258	.283	.214

All dimensions for reference only.
Consult Sidney, NY for specific contact contour stickout data.
NS designates No Stickout.

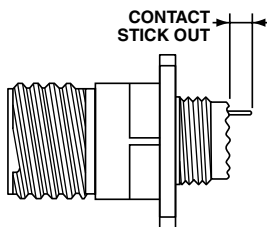

See also catalog 12-170, Amphenol Cylindrical Connectors for PCB Applications. This catalog provides the most commonly used insert pattern pin-out drawings which have been tooled for the purpose of attaching cylindrical connectors to printed circuit boards.

PINS

PCB Pin Contacts	Size	Tail Dia	Contact Stickout Max/Min (See Illustration below)		
			AL00	AL06	AL07
10-407552-15	22M	.019	.335	.360	.286
			.280	.305	.236
10-407552-55	22M	.019	.224	.249	.175
			.169	.194	.125
10-407552-85	22M	.019	.060	.085	.011
			.010	.035	NS
10-407552-95	22M	.019	NS	NS	NS
10-407552-115	22M	.019	.002	.023	NS
			NS	NS	
10-497640-15	20	.019	.348	.373	.299
			.298	.323	.254
10-497640-25	20	.019	.213	.238	.164
			.163	.188	.119
10-497640-45	20	.019	NS	NS	NS
10-497640-65	20	.019	.138	.163	.089
			.088	.113	.044
10-497596-15	20	.025	.058	.083	.009
			.012	.037	NS
10-497596-25	20	.025	.148	.173	.099
			.102	.127	.058
10-497596-35	20	.025	.229	.254	.180
			.183	.208	.139
10-497596-55	20	.025	.346	.371	.297
			.300	.325	.256
10-497695-15	16	.040	.255	.280	.206
			.205	.230	.161
10-497630-25	16	.062	.348	.373	.299
			.298	.323	.254
10-497630-35	16	.062	.060	.085	.011
			.010	.035	NS
10-497630-45	16	.062	.108	.133	.059
			.062	.087	.018
10-597502-15	12	.081	.228	.252	.179
			.178	.203	.134
Wire Wrap Contacts		Tail Square			
10-407572-15	22D	.025	.014	.498	NS
			NS	.007	NS
10-407572-35	22D	.025	.155	.180	.106
			.105	.130	.061
10-407572-45	22D	.025	.255	.280	.206
			.205	.230	.161
10-407572-75	22D	.025	.521	.546	.472
			.475	.500	.431
10-407584-25	20	.025	.605	.630	.556
			.559	.584	.515
10-407584-35	20	.025	.308	.333	.259
			.262	.287	.218

PCB socket and pin numbers include finish designation - gold plating over suitable underplate in accordance with MIL-C-39029. For other finish variations, consult Sidney, NY.

Note: 22M and 22D contacts are interchangeable.

For other contact options available for use in Amphe-Lite connectors (thermocouple, fiber optic), consult Sidney, NY.

Amphe-Lite Series

fiber optic termini – multi-mode, size 16

Amphenol® Multi-mode, Size 16 Termini Features and Performance Levels:

- Ceramic alignment ferrule which precisely positions the fiber within the termini
- Phosphor bronze alignment sleeve, assembled on the socket after polishing insures accurate fiber to fiber alignment (a ceramic alignment sleeve is also available).
- Typical insertion loss for 100/140 fiber with .2 NA at 820 nm is .5 to .7 dB using Air Gap (AG) polish technique
Use of the ceramic ferrule and sleeve maximizes the ability to hold extremely tight dimensional tolerances while maintaining accurate concentricity, thus providing superior and consistent optical loss performance.
- Termination accomplished using the industry proven epoxy/polish method. Can be polished Air Gap (AG) or Physical contact (PC).
- Socket cleaning optional. Consult Amphenol, Sidney, NY for termini cleaning tool. For application tools consult Sidney, NY.

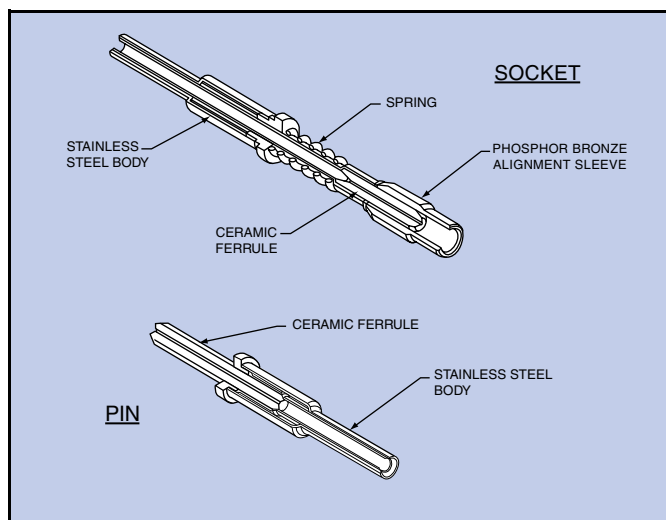

Multi-mode Size 16 Fiber Optic Termini

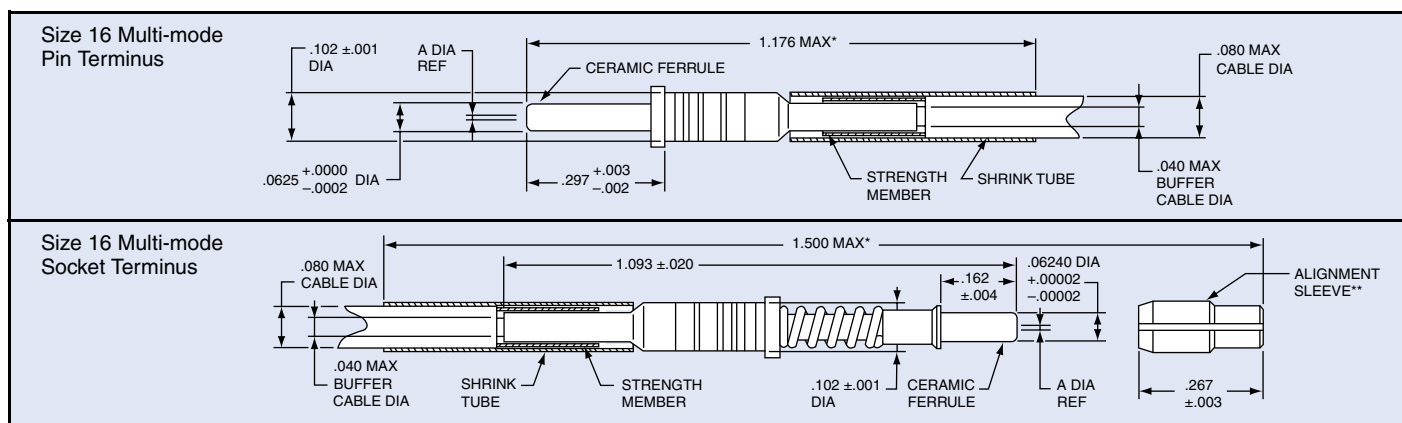

Amphenol® Multi-Channel fiber optic connectors are supplied less contacts. Order multi-mode termini by Amphenol part number designation as shown in the chart below. Consult Amphenol, Sidney, NY for further availability.

* Indicated dimension when fully assembled.
** Alignment sleeve shipped unassembled.

Ordering Information Multi-mode Termini (Size 16) for Amphe-Lite Connectors

Fiber Size† Core/Cladding Dia (Microns)	Size 16 Socket	Size 16 Pin	A Dia Ref	
			Inches	Microns
50/125	CF-198035-010	CF-198036-010	.0050	127
62.5/125				
100/140	CF-198035-017	CF-198036-017	.0057	145
100/140/172	CF-198035-029	CF-198036-029	.0069	175
100/140/172	CF-198035-29A	CF-198036-29A	.0068	173.5
200/230	CF-198035-053	CF-198036-053	.0093	236
200/240	CF-198035-057	CF-198036-057	.0097	245
200/280	CF-198035-074	CF-198036-074	.0114	290
200/300	CF-198035-080	CF-198036-080	.0120	305

† Additional sizes available upon request: consult Amphenol, Sidney, NY for availability.

Power contacts can be purchased separately, contact Amphenol, Sidney, NY.

Amphe-Lite Series

fiber optic termini – multi-mode, size 20

Amphenol® Multi-mode, Size 20 Termini Features and Performance Levels:

- Designed for use in size 20 cavities of Amphe-Lite connectors
- Designed with similar high performance components as the proven size 16 termini
- Comparable performance and reliability to the size 16 termini can be expected
- Offers increased termini density in Amphenol Amphe-Lite connectors
- Maintains fiber optic/electrical hybrid capabilities
- Allows for multiple fiber accommodations
- Termination accomplished using the industry proven epoxy/polish method. Can be polished Air Gap (AG) or Physical contact (PC).
- Socket cleaning optional. Consult Amphenol, Sidney, NY for termini cleaning tool. For application tools consult Sidney, NY.

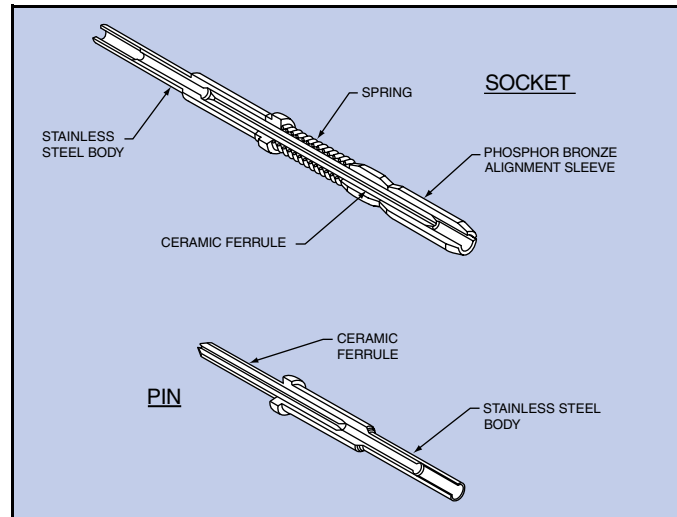

Multi-mode Size 20 Fiber Optic Termini

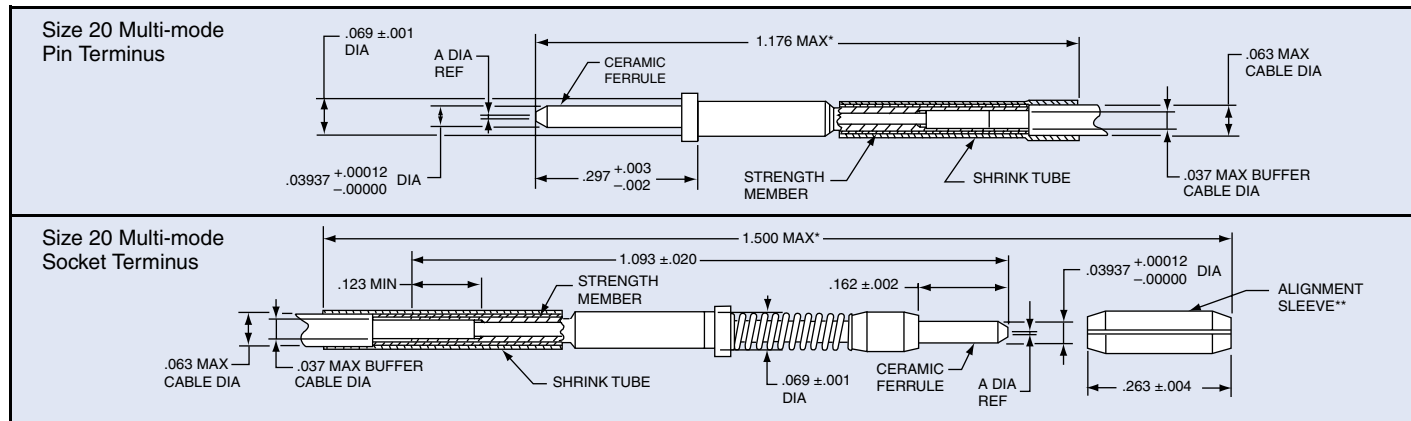

Amphenol® Multi-Channel fiber optic connectors are supplied less contacts. Order multi-mode termini by Amphenol part number designation as shown in the chart below. Consult Amphenol, Sidney, NY for further availability.

* Indicated dimension when fully assembled.
** Alignment sleeve shipped unassembled.

Ordering Information Multi-mode Termini (Size 16) for Amphe-Lite Connectors

Fiber Size† Core/Cladding Dia (Microns)	Size 20 Socket	Size 20 Pin	A Dia Ref	
			Inches	Microns
50/125	CF-198080-010	CF-198081-010	0.0050	127
62.5/125				
100/140	CF-198080-017	CF-198081-017	0.0057	145

† Additional sizes available upon request: consult Sidney, NY for availability.
Power contacts can be purchased separately, contact Sidney, NY.

Amphe-Lite Series

fiber optic termini – 90° multi-mode, size 16

Amphenol provides 90°, size 16 fiber optic termini that can be used with multi-channel cylindrical connectors.

90° Socket Termini (Size 16)

Ordering Information for 90° Multi-mode Socket Termini

Fiber Size† Core/Cladding Dia (Microns)	Socket, Size 16 Amphenol Part Number For use in Cylindrical Connectors	A Dia Ref	
		Inches	Microns
50/125	CF-198111-010	.0050	127
62.5/125			
100/140	CF-198111-017	.0057	145
100/140/172	CF-198111-29	OR	.0069
	CF-198111-29A		.0068

† Additional sizes available upon request: consult Amphenol, Sidney, NY for availability.
* Consult Amphenol, Sidney, NY for ordering information.
** Indicated dimension when fully assembled.
*** Shrink tubing and alignment sleeve are shipped unassembled.

90° Pin Termini (Size 16)

Ordering Information for 90° Multi-mode Pin Termini

Fiber Size† Core/Cladding Dia (Microns)	Pin, Size 16 Amphenol Part Number For use in Cylindrical Connectors	A Dia Ref		B Max (Inches)	C Ref (Inches)
		Inches	Microns		
50/125	CF-198110-010	.0050	127	1.121	1.100
62.5/125					
100/140	CF-198110-017	.0057	145	1.121	1.100
100/140/172	CF-198110-029	OR	.0069	1.121	1.100
	CF-198110-29A		.0068		
50/125	CF-198112-010	.0050	127	1.003	.900
62.5/125					
100/140	CF-198112-017	.0057	145	1.003	.900
100/140/172	CF-198112-029	OR	.0069	1.003	.900
	CF-198112-29A		.0068		

† Additional sizes available upon request: consult Amphenol, Sidney, NY for availability.
* Consult Amphenol, Sidney, NY for ordering information.

Amphe-Lite Series

application tools

The following data includes information pertaining to the application tools which have been established for crimping, inserting, and removing contacts incorporated in the Amphe-Lite Series connectors. For additional information on coaxial contact tools see catalog 12-130.

All crimping tools included are the “full cycling” type.

There is a possibility of additional crimping tools other than those included being available at present or in the future for this specific application.

RECOMMENDED CRIMPING TOOLS

Contact Size/Type	Crimping Tool	Turret Die or Positioner
12 Pin and Socket	M22520/1-01	M22520/1-04
16 Pin and Socket	M22520/1-01 M22520/7-01	M22520/1-04 M22520/7-04
20 Pin and Socket	M22520/1-01 M22520/2-01 M22520/7-01	M22520/1-04 M22520/2-10 M22520/7-08
22D Pin	M22520/2-01 M22520/7-01	M22520/2-09 M22520/7-07
22D Socket	M22520/2-01 M22520/7-01	M22520/2-07 M22520/7-05
8 Twinax Center Pin and Socket	M22520/2-01	M22520/2-37
8 Twinax Intermediate Outer Pin & Socket	M22520/5-01	M22520/5-200

Contact Size/Type	Crimping Tool	Turret Die or Positioner
8 Coaxial Inner Pin and Socket	M22520/2-01	M22520/2-31
8 Coaxial Outer Pin and Socket	M22520/5-01	M22520/5-05 Die Closure B
	M22520/5-01	M22520/5-41 Die Closure B
	M22520/10-01	M22520/10-07 Die Closure B
16 Coaxial Inner Pin and Socket	M22520/2-01	M22520/2-35
16 Coaxial Outer Pin and Socket	M22520/4-01	M22520/4-02
12 Coaxial Inner Pin and Socket	M22520/2-01	M22520/2-34
12 Coaxial Outer Pin and Socket	M22520/31-01	M22520/31-02
10 (Power)	TP201423	1716P-1

Where 2 or 3 tools are listed for a contact size, only one tool and its die or positioner are required to crimp the contact.

The above crimping tools and positioners are available from the approved tool manufacturer.

INSERTION TOOLS

Use with Contact Size	Plastic Tools		Metal Tools			
	MS Part Number	Color	Angle Type		Straight Type Proprietary Part Number	Color
			MS Part Number	Proprietary Part Number		
10 (Power)	M81969/14-05*	Gray / (White)	M81969/8-11	†	†	Green
12	M81969/14-04*	Yellow / (White)	M81969/8-09	11-8674-12	11-8794-12	Yellow
16	M81969/14-03*	Blue / (White)	M81969/8-07	11-8674-16	11-8794-16	Blue
20	M81969/14-10*	Red / (Orange)	M81969/8-05	11-8674-20	11-8794-20	Red
22D	M81969/14-01*	Green / (White)	M81969/8-01	11-8674-24	11-8794-24	Black
8 Coaxial	None Required					
8 Twinax	None		M81969/46-06**	None		Red

REMOVAL TOOLS

Use with Contact Size	Plastic Tools		Metal Tools				
	MS Part Number	Color	For Unwired Contacts Proprietary Part Number	Angle Type		Straight Type Proprietary Part Number	Color
				MS Part Number	Proprietary Part Number		
10 (Power)	M81969/14-05*	(Gray) / White	†	M81969/8-12	†	†	Green / White
12	M81969/14-04*	(Yellow) / White	11-10050-11	M81969/8-10	11-8675-12	11-8795-12	Yellow / White
16	M81969/14-03*	(Blue) / White	11-10050-10	M81969/8-08	11-8675-16	11-8795-16	Blue / White
20	M81969/14-10*	(Orange) / Red	11-10050-9	M81969/8-06	11-8675-20	11-8795-20	Red / White
22D	M81969/14-01*	(Green) / White	11-10050-7	M81969/8-02	11-8675-24	11-8795-24	Green / White
8 Coaxial	M81969/14-12	Green	None	None	11-9170	DRK264-8††	N/A
8 Twinax	M81969/14-12	Green	None	M81969/46-12**	11-9170	N/A	N/A

The M81969/8, 11-8674, 11-8675, and 11-8794 metal contact insertion and removal tools will accommodate wires having the maximum outside diameter as follows: Contact size 12–.155, 16–.109, 20–.077, 22D–.050. When wire diameters exceed those specified, the plastic tools must be used.

* Double end insertion/removal tool.

† To be determined.

** Twinax insertion tools are available only in a straight type, metal version..

†† Contact Daniels Manufacturing Co. for availability.

Amphe-Lite Series

how to order

Amphenol® Amphe-Lite Composite Connectors can be ordered by coded part number. Ordering procedure is illustrated by part number AL00F9-35PB as shown below:

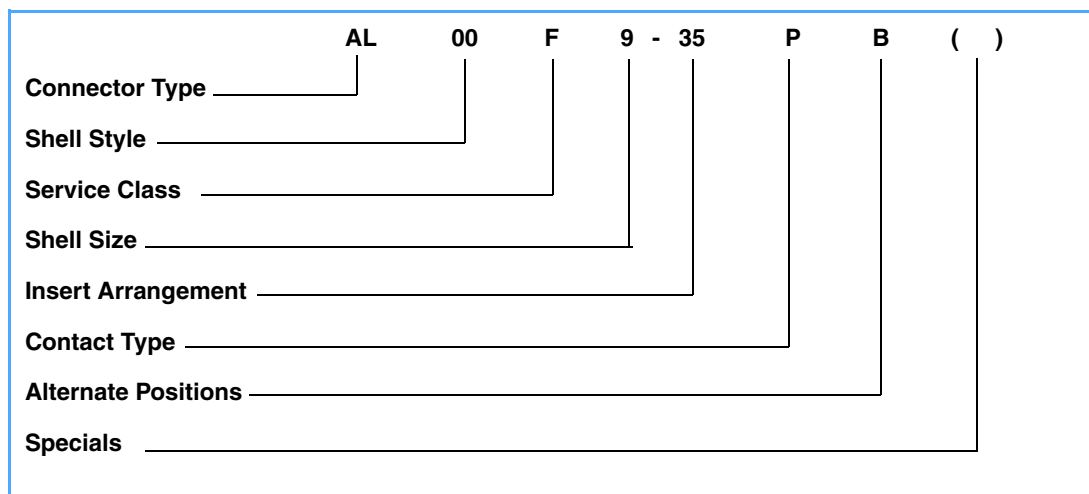

Connector Type

AL designates Amphe-Lite Connector Series

Shell Style

00 designates wall mount receptacle
06 designates straight plug
07 designates jam nut receptacle

Service Class

F electroless nickel plated composite
U black composite, unplated
X black zinc alloy, conductive, composite

Shell Size

9 thru 25 available

Insert Arrangement

See insert arrangement chart, page 3. See insert configurations illustrated on pages 5-8.

Contact Type

P designates standard 500 cycle pin contacts
S designates standard 500 cycle socket contacts

Alternate Positions

Locksmith keying - rotation of minor keys. "N" not required for normal position, see page 4.

Specials

Specials include optional contact styles and contact platings. Also includes a high decoupling style of Amphe-Lite. Consult Amphenol, Sidney, NY for part numbering suffix for specials.

Standard Packaging

The Amphe-Lite Series is shipped with connectors and contacts packaged in bulk. Consult Amphenol, Sidney NY for special packaging requirements

Amphe-Lite – capabilities

fiber optics, filter contacts, flex termination, coax contacts

FIBER OPTIC

Fiber optic terminators offer a precision optic interconnect system within the Amphe-Lite connector. The Amphe-Lite connector provides protection from damage in severe environmental and physical conditions. Optical performance is optimized utilizing the ceramic alignment features employed by the terminators. Insertion losses are typically .8dB and can range from .5 to 1.5 dB, depending on test conditions.

See pages 18-20 for fiber optic terminator features and how to order. Ask for publication 12-352 or contact Sidney, NY for more information on Amphenol Fiber Optic Connectors.

Also available with MT and LC termination within an Amphe-Lite shell kit. Contact Amphenol, Sidney for more information.



Fiber Optics

FILTER CONTACTS FOR EMI PROTECTION

EMI shielding protection devices can be integrated into the Amphe-Lite connector to provide a cost effective alternative to discrete devices mounted inside the box. These unique, high performance designs provide weight and space savings necessary for modern electronic systems.

Ask for publication 12-120 or contact Amphenol, Sidney, NY for complete information on Amphenol Filter/Transient Protection Connectors.



Filter Contacts



Flex Termination Assemblies

FLEX TERMINATION ASSEMBLIES FOR PRINTED CIRCUIT BOARD APPLICATIONS

Amphenol provides flex termination assemblies for printed circuit board attachment. Flex circuits are available for Amphe-Lite connectors in flat or sculptured styles. Sculptured® Flexible Circuits with built-in terminations eliminate the failures associated with crimped or solder-on contacts, and they are designed to geometrically fit the tight space requirements within a unit. They plug into a printed circuit board and create a self-locking terminal pad which eliminates the need for an additional interconnect to the PCB.

Ask for catalog 12-170, Amphenol Cylindrical Connectors for PCB Applications.

CONNECTORS WITH COAX CONTACTS

For shielded wire applications, coaxial contacts can be incorporated into Amphe-Lite connectors. Designed-in crimp or solder types are available to fit various RG and special cables. High performance coaxial contacts eliminate discontinuities or impedance variations due to movement of parts under axial load.

For further information on coax contacts ask for catalog 12-130.

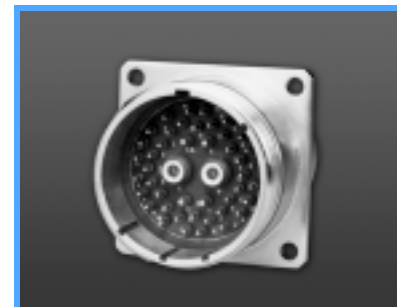

Coax Contacts

Amphe-Lite Series – capabilities

ground plane connectors, twinax contacts, power contacts

GROUND PLANE CONNECTORS

Amphenol offers Amphe-Lite connectors for data bus, LAN and coax/triax/twinax transmission lines with conductive inserts that ground the outer conductor of the coax, triax or twinax contact to the shell. These connectors are sold “less contacts”. They will accommodate size 8 coax, triax or twinax contacts or size 12 and 16 coax contacts.

The insert availability chart on page 3 indicates the patterns that are available in a ground plane version, (see those designated with a star symbol), and consult Amphenol, Sidney NY for ordering procedures.

CONNECTORS WITH CONCENTRIC TWINAX CONTACTS

The size 8 concentric twinax contact was developed for use in MIL-STD-1553 Airborne multiplex data bus applications which require high performance interconnect characteristics in multi-pin connectors. The Amphe-Lite Series with concentric twinax contacts are ideal for communication data bus applications. The concentric twinax contact is crimp terminable to twisted-shielded cable.

For further information on concentric twinax contacts ask for Amphenol Catalog 12-130.

CONNECTORS WITH REDUCED COMPONENT TWINAX (RCT) CONTACTS

The RCT (Reduced Component Twinax) contact meets MIL-C-39029/90 and /91 requirements for interchangeability and performance while reducing the number of user-assembled components from seven to three. The inner conductors and outer barrel of the RCT are each terminated to the cable by a crimp joint, so no costly assembly soldering operations are required. Features include:

- Three user assembled components
- Available in size 8 and size 10 contacts
- MIL-C-17/176-00002 cable termination
- For installation in Amphe-Lite connectors
- Termination completed in only two crimping operations
- Inner conductors stripped to common length, eliminating multiple measurements

For further information on RCT contacts ask for Amphenol Catalog 12-130.

CONNECTORS WITH POWER CONTACTS

Size 10 power, size 12 and size 16 contacts are available in many standard insert arrangements. These contacts provide a wide range of power transmission capabilities. Standard contacts are gold plated to maintain a superior conductive surface. For further information on insert patterns that contain power contacts refer to the insert availability chart on page 3.

CONNECTORS FOR RJ AND USB INTERFACE

Amphe-Lite connector kits are also available with RJ and USB connector interfaces within the ruggedized Amphe-Lite connector shell. Contact Amphenol, Sidney, NY for more information.



Ground Plane Connector with Metallic Insert and Concentric Twinax Contacts



Concentric Twinax Contacts Qualified to M39029/90 and /91

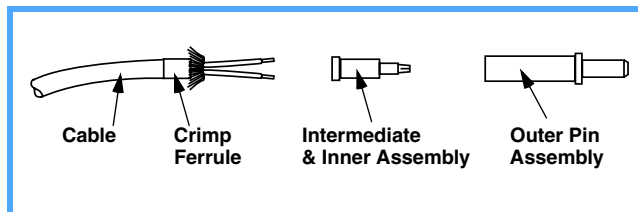

RCT (Reduced Component Twinax) Contact



Connectors for RJ Interface

X-ON Electronics

Largest Supplier of Electrical and Electronic Components

Click to view similar products for [Circular MIL Spec Connector](#) category:

Click to view products by [Amphenol](#) manufacturer:

Other Similar products are found below :

[89075GULPR](#) [0025-262-542](#) [0025-264-3014](#) [58-570121-04S](#) [0134-213-1208](#) [0134-213-2209](#) [0025-258-000](#) [60-042022-07P](#) [60-042022-19P](#)
[60-042022-23P](#) [60-042217-10P](#) [0114-201-1278](#) [012-0467-000](#) [602GB06EG24-61SN](#) [0134-201-1207](#) [0134-213-1006](#) [6104-207-2302](#) [6104-](#)
[208-1902](#) [61-168211-04P](#) [61-168617-10P](#) [6131-202-19149P](#) [6131-204-21149P](#) [6131-208-13149P](#) [6131-209-17149P](#) [6131-210-11149P](#) [6131-](#)
[211-19149P](#) [6131-216-19149P](#) [6131-259-21149P](#) [6131-259-23149P](#) [6131-265-17149P](#) [6131-265-19149P](#) [CS3100A18-1P-472](#) [CS3100A-36-](#)
[77P](#) [CS3101A-16-55P](#) [CS3102A-10SL-55P](#) [CS3102A-14S-58P](#) [CS3102A-32-17P](#) [CS3102A32-25S](#) [CS3102C18-4P-472](#)
[CS3106A10SL3S004](#) [CS3106A-18-73S](#) [CS3108A-14S-52S](#) [CS3108A-28-51S](#) [6162-233-1277](#) [6162-324-1231](#) [M243082296Z](#)
[M2884010AC1S1](#) [CT0-24-10SC](#) [CT0M20-7PCAU](#) [M28840/17AC1G3](#)