

Product Data Sheet

Amphenol® Pre-Earth/FMLB Connectors

No. 187

Amphenol® Pre-Earth/First Mate Last Break Connectors are designed for applications where a protective circuit from the ground contact to the shell is a safety requirement. These connectors provide a path for any stray voltage to be shunted to a safe ground avoiding harm to the operator and the voltage sensitive equipment.

Pre-Earth (ground) contact mates first and provides safety from voltage outputs - protects operators and sensitive circuits.

Amphenol's DL Series Pre-Earth/FMLB connectors are certified to European safety standards for use in the factory automation, machine tool and process control applications. This series is certified to be CE compliant and is tested in accordance with DIN VDE 0627 by the TUV Product Service GMBH.

DL Series connectors employ shells and inserts to MIL-C-5015 styles and arrangements. They utilize solder cup contacts and aluminum shells. When mated, these connectors meet Class IP67 protection against water and dust.

The FMLB function of these connectors is achieved during the mating cycle of plug and receptacle, when the longer socket contact in the plug makes electrical engagement prior to the mating of the balance of the contacts. Potential harm to electronic circuits is circumvented.

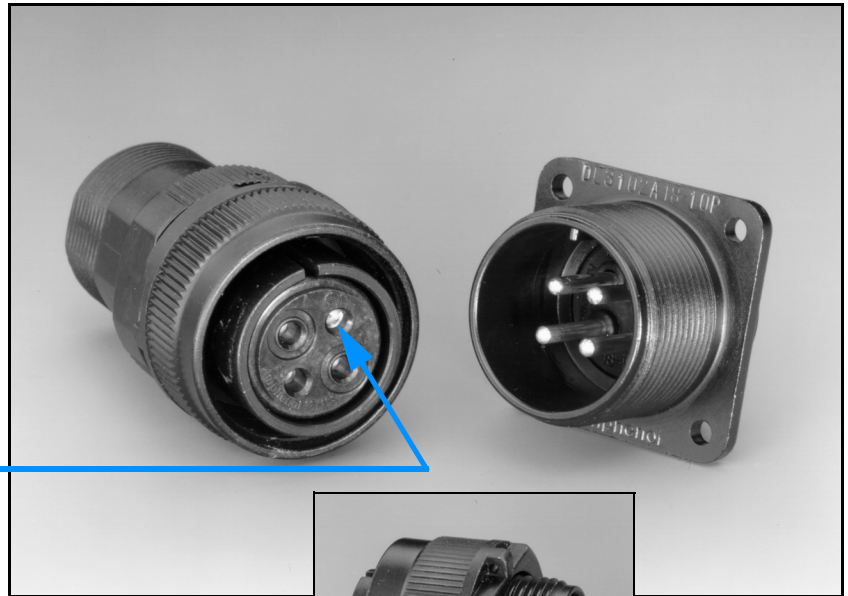

Contact is grounded to the shell.

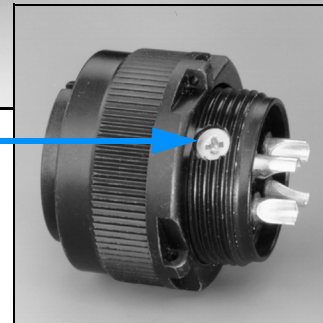

Features of Amphenol® DL Series Connectors:

- MIL-C-5015 dimensions and performance where applicable.
- Conformity with European safety standards (DIN VDE 0627 and certified through TUV Product Service GMBH) in the approved insert arrangement. (See current available arrangements on next page)
- Offered in shell styles: 3102A box mount, 3106A straight plug, 3108A 90 degree plug.
- Intermateable with MS 5015 and 97 Series styles.
- Class IP67 protection in the mated condition.
- Main joint gasket between plug and receptacle shells provides superior moisture sealing.
- Pre-earth (ground contact) design.
- First mate, last break capability.
- Standard plating is black zinc alloy. Green zinc plating is an available option.

Notice: Specifications are subject to change without notice. Contact your nearest Amphenol Corporation Sales Office for the latest specifications. All statements, information and data given herein are believed to be accurate and reliable but are presented without guarantee, warranty, or responsibility of any kind, expressed or implied. Statements or suggestions concerning possible use of our products are made without representation or warranty that any such use is free of patent infringement and are not recommendations to infringe any patent. The user should assume that all safety measures are indicated or that other measures may not be required. Specifications are typical and may not apply to all connectors.

AMPHENOL is a registered trademark of Amphenol Corporation.

©2001 Amphenol Corporation

Amphenol

Printed in U.S.A. QG 1/2001

Pre-Earth/FMLB Connectors

The following chart shows the currently available insert arrangements in the new Pre-Earth DL Series.

Shell and Insert Arrangement No.	10SL-3	18-10	18-12	20-15	22-22	24-10 (G)	24-10
Arrangement (Front View of Pin Insert)							
Contact Size	#16	#12	#16	#12	#8	#8	#8
No. of Contacts	3	4	6	7	4	7	7
Pre-Earth Contact Position	C	D	D	D	D	G (Pre-Earth contact in Plug only)	D
Voltage Rating	DC (V)	300	350	350	350	350	350
	AC (V)	200	250	250	250	250	250
D.W.V. (AC Vrms)	2000						
Insulation Resistance	$\geq 5000M\Omega$ (DC500V)						

Wire Size and Current Rating

Contact Size	Wire Size	Current Rating (\leq)
#16	AWG #16 to #22	13A
#12	AWG #12 to #14	23A
#8	AWG #8 to #10	46A
#4	AWG #4 to #6	80A

HOW TO ORDER DL CONNECTORS

$\frac{DL}{1}$ $\frac{3102}{2}$ $\frac{A}{3}$ $\frac{18-12}{4}$ $\frac{P}{5}$

1. Connector Type
DL designates Amphenol® Pre-Earth/FMLB Connector
2. Shell Style
3102 designates box mount receptacle
3106 designates straight plug
3108 designates 90 degree plug
3. Service Class or special contact termination
"A" designates general duty
4. Shell Size and Insert Arrangement Number
See chart above for currently available arrangements
5. Contact Type (P designates pin, S designates socket)

The pre-earth connector uses standard MIL-C-5015 type accessories. For accessories such as clamps, protection caps and adapters, consult Amphenol catalog for 97 series (MIL-C-5015 type) connectors (Publication No. 12-022).

For further information and assistance on ordering Amphenol® Pre-Earth/FMLB Connectors, contact your local Amphenol sales office or:

Amphenol Corporation
Amphenol Industrial Operations
40 – 60 Delaware Avenue
Sidney, New York 13838-1395
Phone: 607-563-5011
Fax: 607-563-5351
www.amphenol-aerospace.com