

**DUAL LOW NOISE OPERATIONAL AMPLIFIERS****AZ4580****General Description**

The AZ4580 is a monolithic dual low noise operational amplifier. It is specifically designed for audio systems to improve tone control; it can also be used in pre-amplifier, industrial measurement tools and applications where gain and phase matched channels are mandatory.

The IC features internal frequency compensation, low noise, low distortion, high gain and high bandwidth. The AZ4580 can operate under dual power supply voltage up to  $\pm 18\text{V}$  or single power supply up to  $36\text{V}$ .

The AZ4580 is available in DIP-8, SOIC-8 and TSSOP-8 packages.

**Features**

- Large Signal Voltage Gain: 110dB Typical
- Low Input Noise Voltage:  $0.7\mu\text{V}_{\text{RMS}}$  (RIAA) Typical
- Wide Gain Bandwidth Product: 15MHz at 10KHz Typical
- Low Distortion: 0.0005% Typical
- Slew Rate:  $7\text{V}/\mu\text{s}$  Typical

**Applications**

- Audio AC-3 Decoder System
- Audio Amplifier

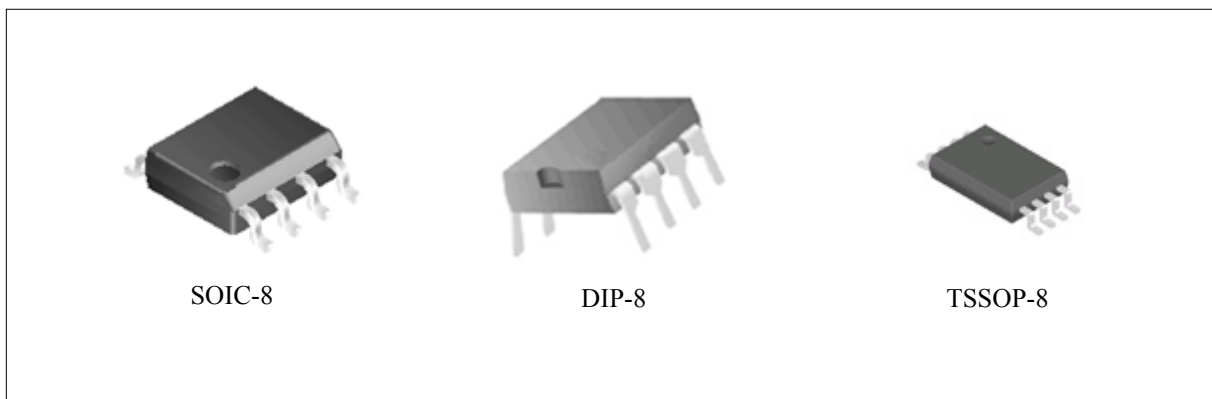

Figure 1. Package Types of AZ4580

**Pin Configuration**

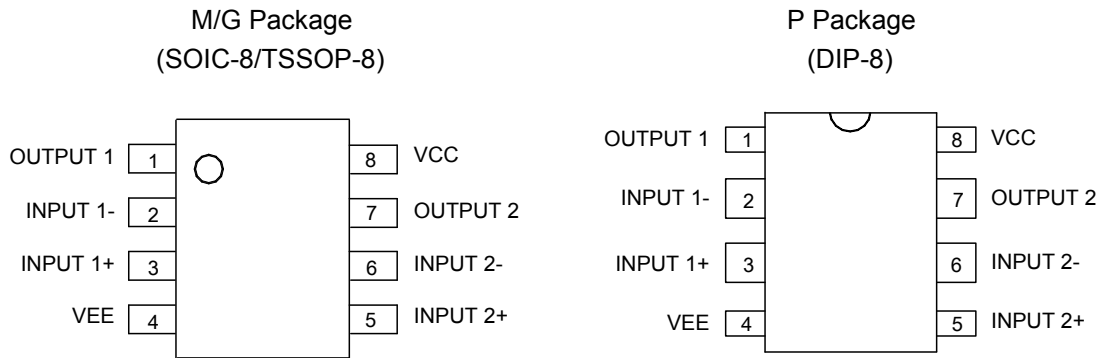

Figure 2. Pin Configuration of AZ4580

**Pin Description**

Pin No.	Function	Pin No.	Function	Pin No.	Function	Pin No.	Function
1	OUTPUT 1	2	INPUT 1-	3	INPUT 1+	4	VEE
5	INPUT 2+	6	INPUT 2-	7	OUTPUT 2	8	VCC

**Functional Block Diagram**

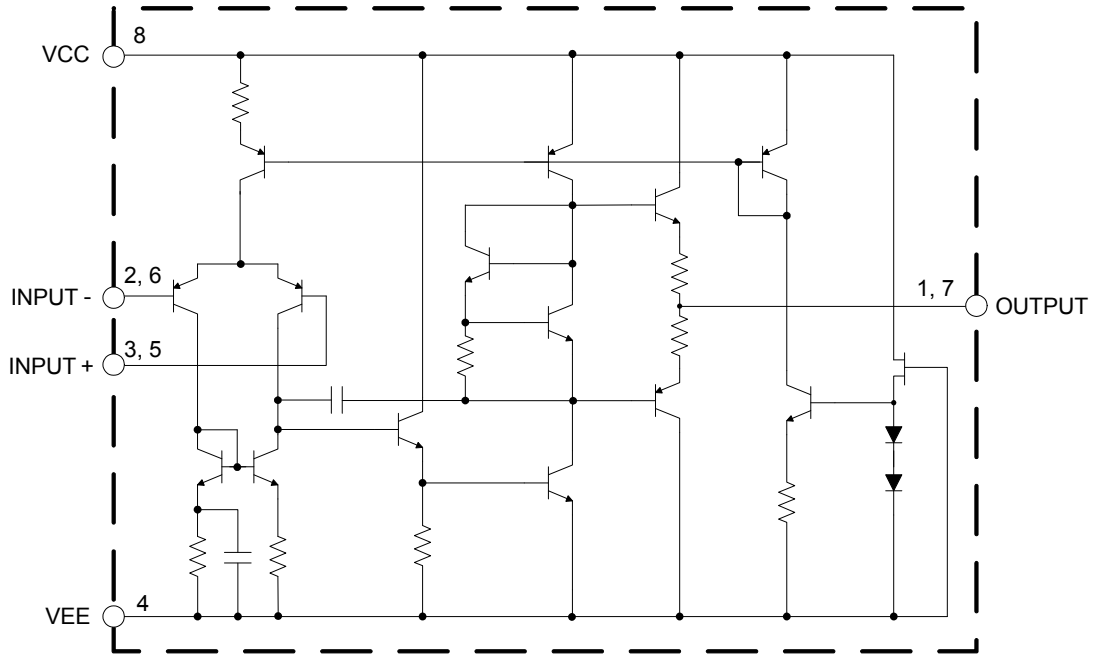
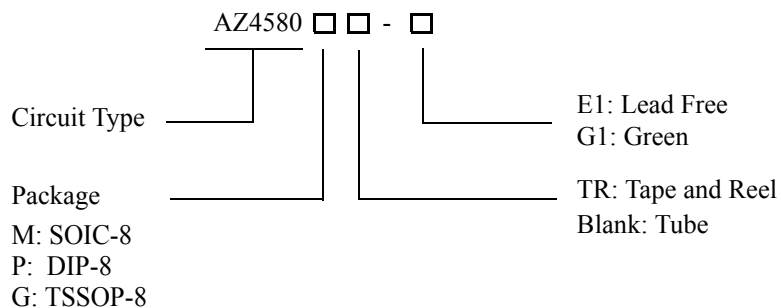

Figure 3. Representative Schematic Diagram of AZ4580 (Each Amplifier)



**DUAL LOW NOISE OPERATIONAL AMPLIFIERS** **AZ4580**

**Ordering Information**



Package	Temperature Range	Part Number		Marking ID		Packing Type
		Lead Free	Green	Lead Free	Green	
SOIC-8	-40 to 85°C	AZ4580M-E1	AZ4580M-G1	4580M-E1	4580M-G1	Tube
		AZ4580MTR-E1	AZ4580MTR-G1	4580M-E1	4580M-G1	Tape & Reel
DIP-8	-40 to 85°C	AZ4580P-E1	AZ4580P-G1	AZ4580P-E1	AZ4580P-G1	Tube
TSSOP-8	-40 to 85°C	AZ4580GTR-E1	AZ4580GTR-G1	EG80	GG80	Tape & Reel

BCD Semiconductor's Pb-free products, as designated with "E1" suffix in the part number, are RoHS compliant. Products with "G1" suffix are available in green packages.

**DUAL LOW NOISE OPERATIONAL AMPLIFIERS****AZ4580****Absolute Maximum Ratings (Note 1)**

Parameter	Smbol	Value	Unit	
Power Supply Voltage	$V_{CC}$	+ 20	V	
	$V_{EE}$	- 20		
Input Voltage	$V_I$	$\pm 15$	V	
Differential Input Voltage	$V_{ID}$	$\pm 30$	V	
Operating Junction Temperature	$T_J$	150	$^{\circ}C$	
Storage Temperature Range	$T_{STG}$	-65 to 150	$^{\circ}C$	
Lead Temperature (Soldering 10s)	$T_L$	260	$^{\circ}C$	
Power Dissipation ( $T_A=25^{\circ}C$ )	$P_D$	TSSOP-8	400	mW
		SOIC-8	500	
		DIP-8	800	

Note 1: Stresses greater than those listed under "Absolute Maximum Ratings" may cause permanent damage to the device. These are stress ratings only, and functional operation of the device at these or any other conditions beyond those indicated under "Recommended Operating Conditions" is not implied. Exposure to "Absolute Maximum Ratings" for extended periods may affect device reliability.

**Recommended Operating Conditions**

Parameter	Min	Max	Unit
Supply Voltage	$\pm 2$	$\pm 18$	V
Operating Temperature Range	-40	85	$^{\circ}C$

**DUAL LOW NOISE OPERATIONAL AMPLIFIERS****AZ4580****Electrical Characteristics**Operating Conditions:  $V_{CC}=+15V$ ,  $V_{EE}=-15V$ ,  $T_A=25^{\circ}C$  unless otherwise specified.

Parameter	Conditions	Min	Typ	Max	Unit
Supply Current	no load		4	7	mA
Input Offset Voltage	$R_S \leq 10K\Omega$		0.5	3	mV
Input Offset Current	$V_{CM}=0V$		5	100	nA
Input Bias Current	$V_{CM}=0V$		150	500	nA
Input Common Mode Voltage Range		$\pm 12$	$\pm 13.5$		V
Common Mode Rejection Ratio	$V_{CM}=0V$ to $V_{CC}-1.5V$ , $R_S \leq 10K\Omega$	80	110		dB
Large Signal Voltage Gain	$R_L=2K\Omega$ , $V_O=\pm 10V$	90	110		dB
Power Supply Rejection Ratio	$R_S \leq 10K\Omega$	80	110		dB
Output Sink Current	$V-=1V$ , $V+=0V$ , $V_O=2V$		80		mA
Output Source Current	$V+=1V$ , $V-=0V$ , $V_O=2V$		45		mA
Slew Rate	$R_L \geq 2K\Omega$		7		V/ $\mu$ S
Gain Bandwidth Product	$R_L=2K\Omega$ , $f=10KHz$		15		MHz
Total Harmonic Distortion	$A_V=20dB$ , $V_O=5V$ $R_L=2K\Omega$ , $f=1KHz$		0.0005		%
Equivalent Input Noise Voltage	RIAA $R_S=50\Omega$ , 30KHz LPF		0.7		$\mu V_{RMS}$
Thermal Resistance (Junction to Case)	DIP-8		43		$^{\circ}C/W$
	SOIC-8		63		



Typical Performance Characteristics

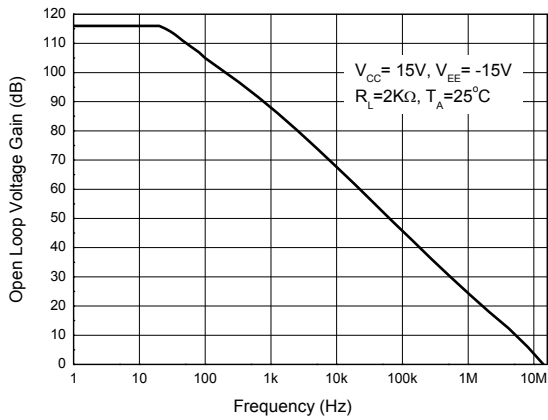

Figure 4. Open Loop Voltage Gain vs. Frequency

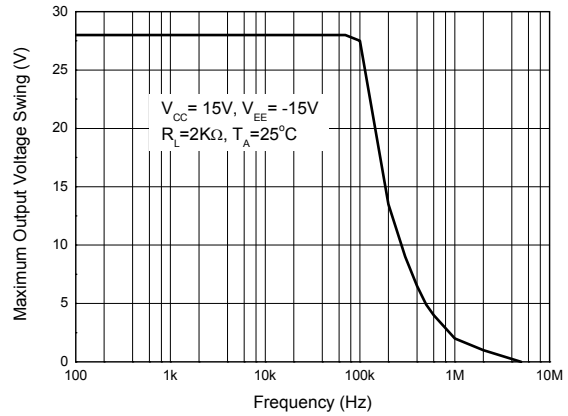

Figure 5. Maximum Output Voltage Swing vs. Frequency

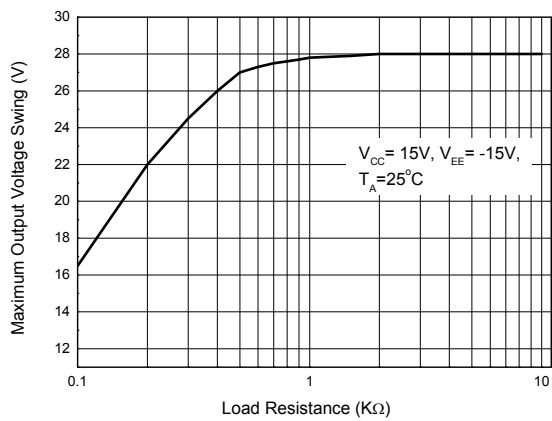

Figure 6. Maximum Output Voltage Swing vs. Load Resistance

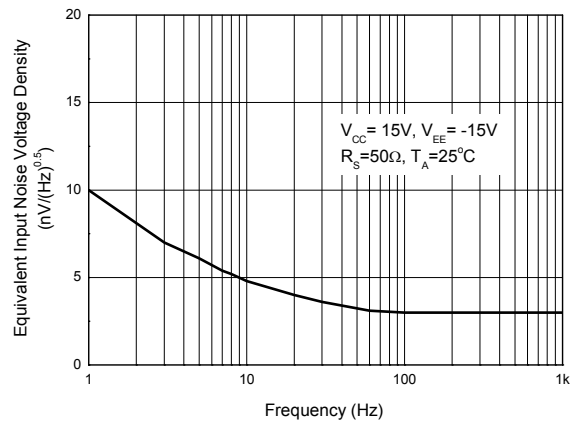

Figure 7. Equivalent Input Noise Voltage Density vs. Frequency

**Typical Performance Characteristics (Continued)**

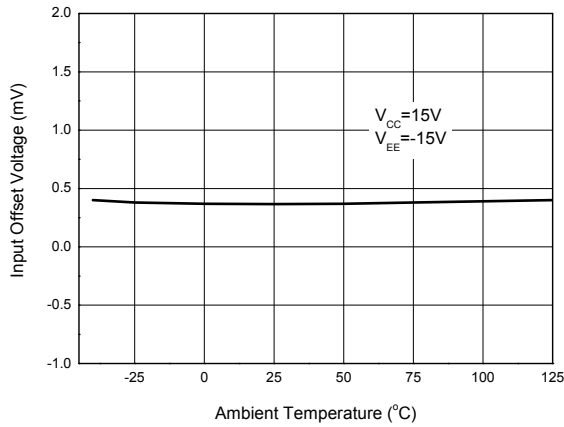

Figure 8. Input Offset Voltage vs. Temperature

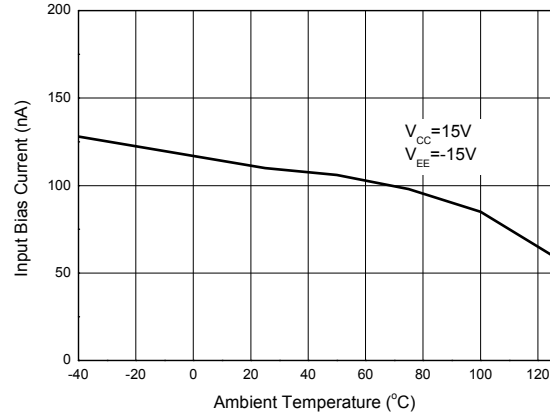

Figure 9. Input Bias Current vs. Temperature

**Typical Applications**

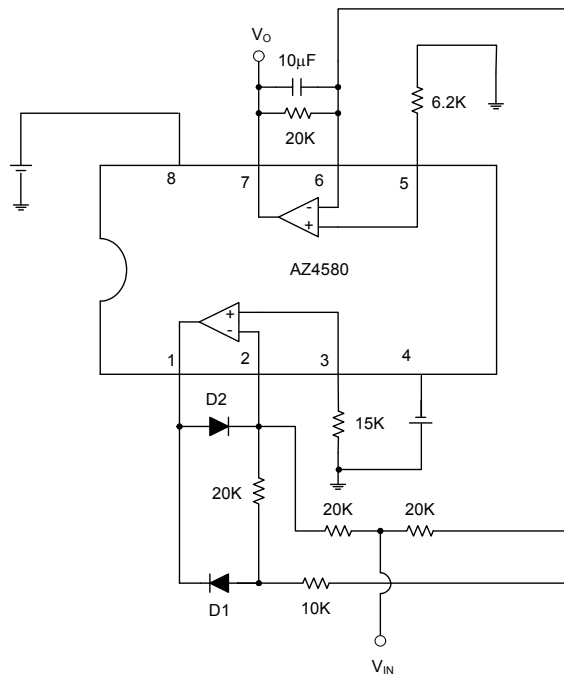

Figure 10. Application of AZ4580 in an AC/DC Converter

**Typical Applications (Continued)**

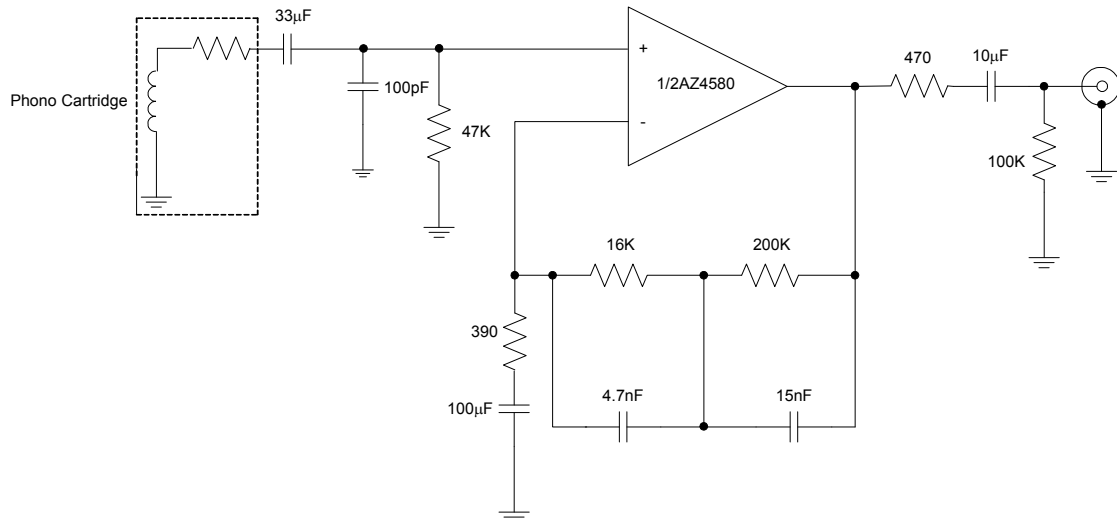

Figure 11. Application of AZ4580 in a RIAA Preamp

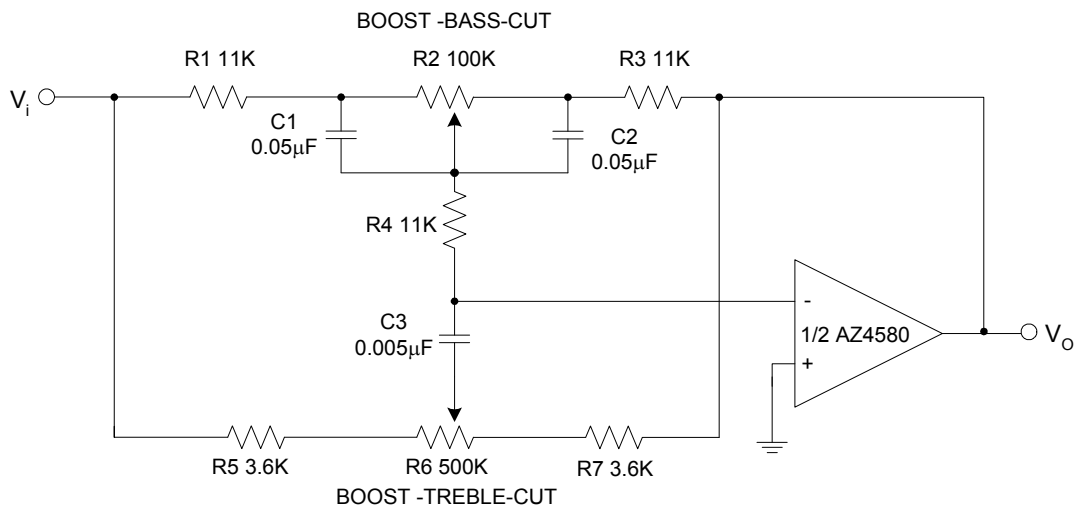

Figure 12. Application of AZ4580 in Tone Control



Mechanical Dimensions

DIP-8

Unit: mm(inch)

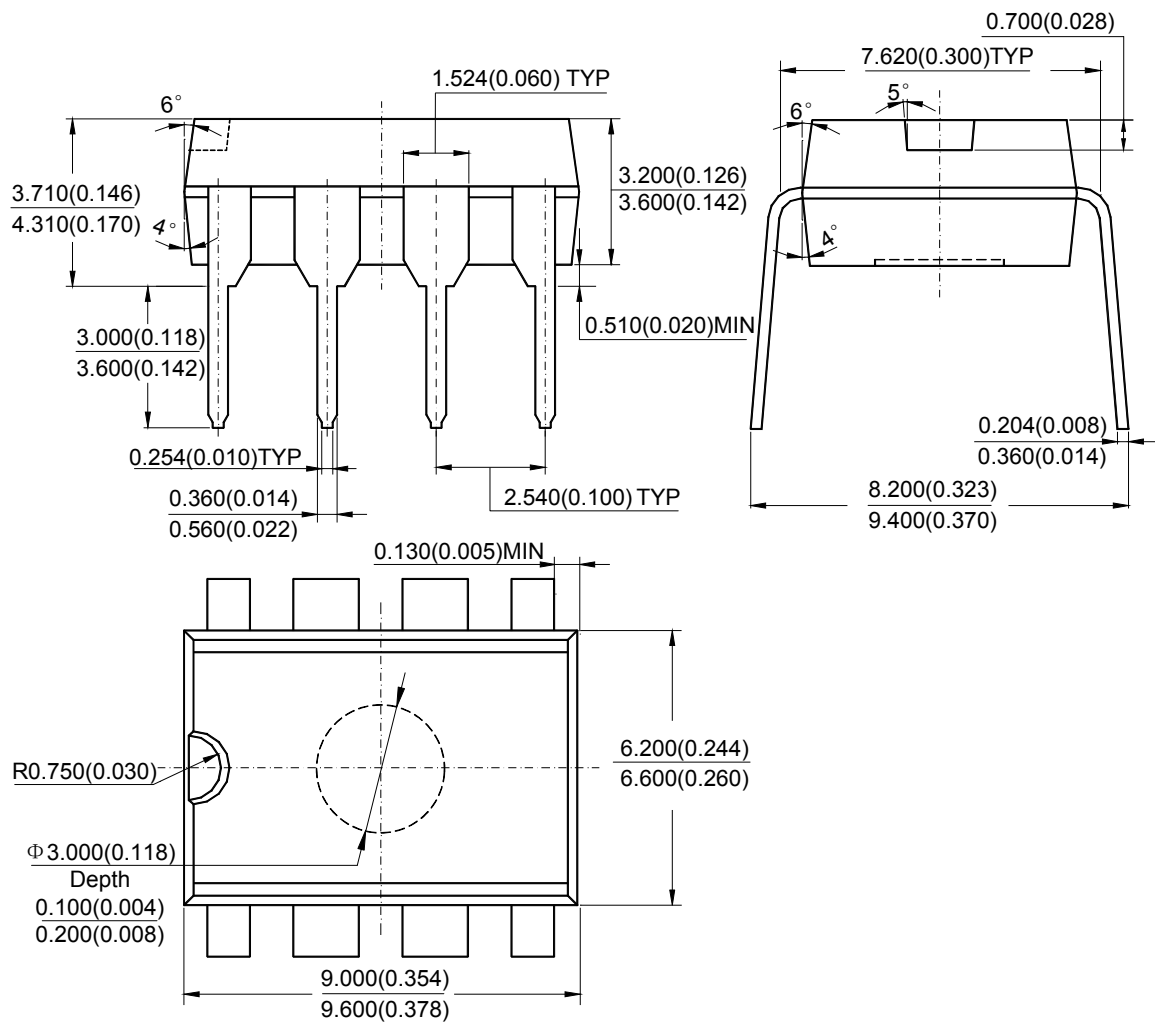

Note: Eject hole, oriented hole and mold mark is optional.



Mechanical Dimensions (Continued)

SOIC-8

Unit: mm(inch)

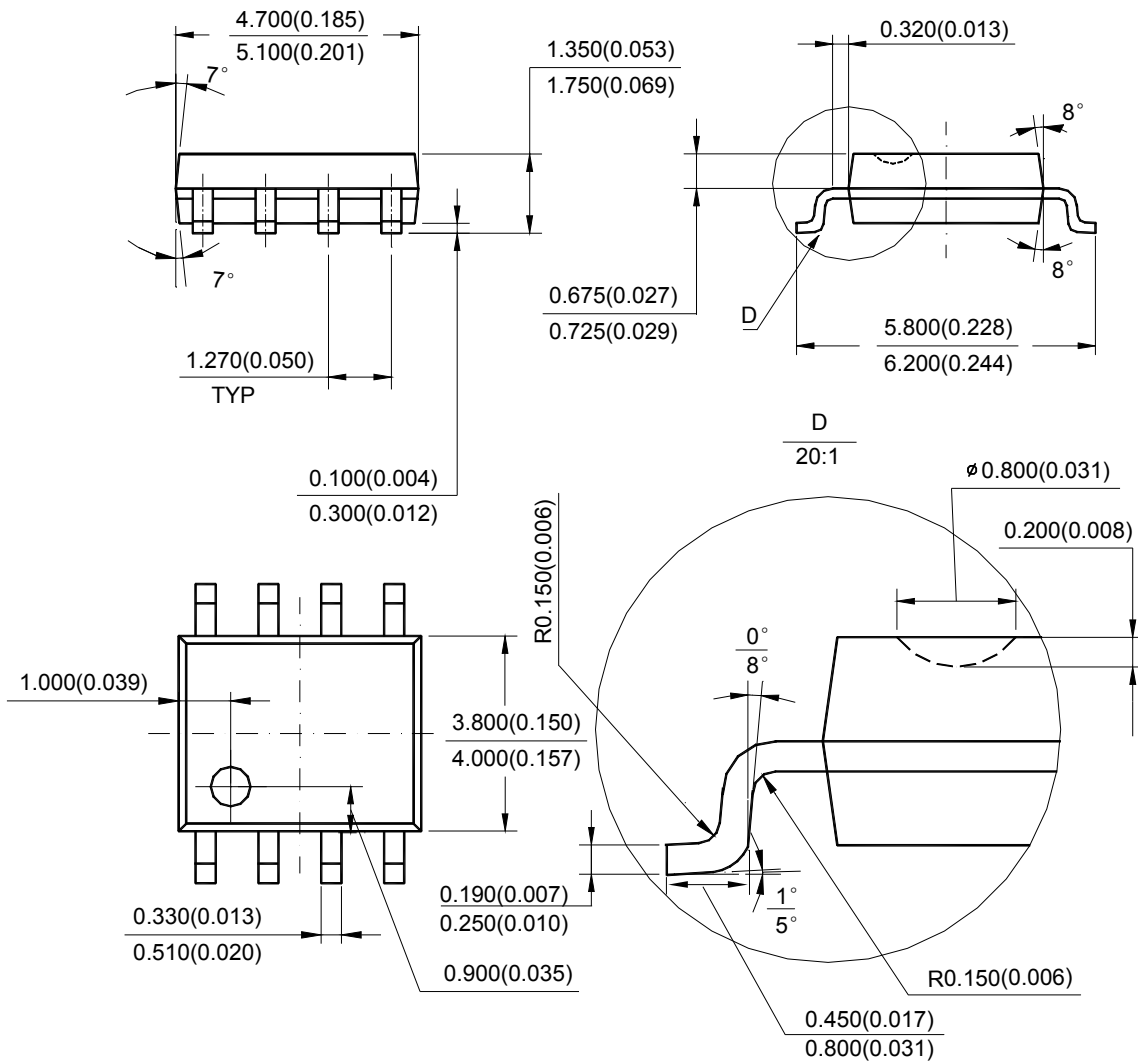

Note: Eject hole, oriented hole and mold mark is optional.



Mechanical Dimensions (Continued)

TSSOP-8

Unit: mm(inch)

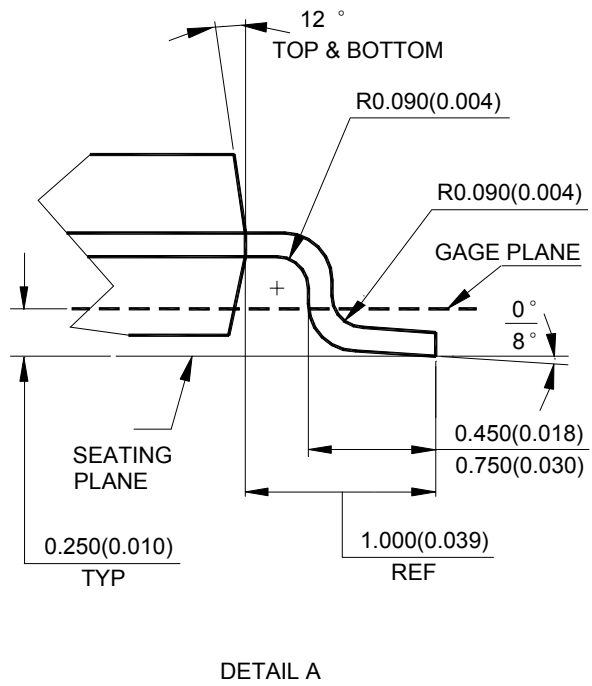
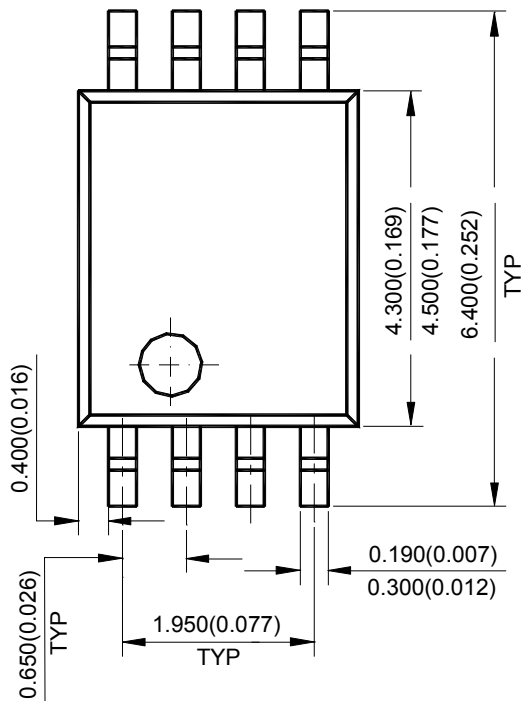
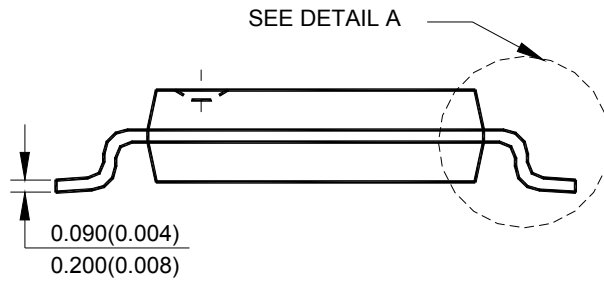
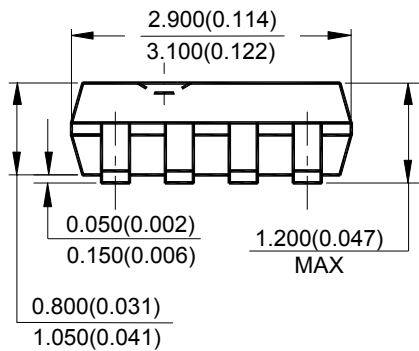

Note: Eject hole, oriented hole and mold mark is optional.



## **BCD Semiconductor Manufacturing Limited**

<http://www.bcdsemi.com>

### **IMPORTANT NOTICE**

BCD Semiconductor Manufacturing Limited reserves the right to make changes without further notice to any products or specifications herein. BCD Semiconductor Manufacturing Limited does not assume any responsibility for use of any its products for any particular purpose, nor does BCD Semiconductor Manufacturing Limited assume any liability arising out of the application or use of any its products or circuits. BCD Semiconductor Manufacturing Limited does not convey any license under its patent rights or other rights nor the rights of others.

---

#### **MAIN SITE**

##### **- Headquarters**

##### **BCD Semiconductor Manufacturing Limited**

No. 1600, Zi Xing Road, Shanghai Zizhu Science-based Industrial Park, 200241, China  
Tel: +86-21-24162266, Fax: +86-21-24162277

##### **- Wafer Fab**

##### **Shanghai SIM-BCD Semiconductor Manufacturing Co., Ltd.**

800 Yi Shan Road, Shanghai 200233, China  
Tel: +86-21-6485 1491, Fax: +86-21-5450 0008

#### **REGIONAL SALES OFFICE**

##### **Shenzhen Office**

##### **Shanghai SIM-BCD Semiconductor Manufacturing Co., Ltd., Shenzhen Office**

Unit A Room 1203, Skyworth Bldg., Gaoxin Ave. 1.S., Nanshan District, Shenzhen, China  
Tel: +86-755-8826 7951  
Fax: +86-755-8826 7865

##### **Taiwan Office**

##### **BCD Semiconductor (Taiwan) Company Limited**

4F, 298-1, Rui Guang Road, Nei-Hu District, Taipei, Taiwan  
Tel: +886-2-2656 2808  
Fax: +886-2-2656 2806

##### **USA Office**

##### **BCD Semiconductor Corp.**

30920 Huntwood Ave. Hayward, CA 94544, USA  
Tel : +1-510-324-2988  
Fax: +1-510-324-2788

## X-ON Electronics

Largest Supplier of Electrical and Electronic Components

*Click to view similar products for [Operational Amplifiers - Op Amps](#) category:*

*Click to view products by [Diodes Incorporated](#) manufacturer:*

Other Similar products are found below :

[OPA2991IDSGR](#) [OPA607IDCKT](#) [007614D](#) [633773R](#) [635798C](#) [635801A](#) [702115D](#) [709228FB](#) [741528D](#) [NCV33072ADR2G](#)  
[SC2903VDR2G](#) [LM258AYDT](#) [LM358SNG](#) [430227FB](#) [430228DB](#) [460932C](#) [AZV831KTR-G1](#) [409256CB](#) [430232AB](#) [LM2904DR2GH](#)  
[LM358YDT](#) [LT1678IS8](#) [042225DB](#) [058184EB](#) [070530X](#) [714228XB](#) [714846BB](#) [873836HB](#) [MIC918YC5-TR](#) [TS912BIYDT](#)  
[NCS2004MUTAG](#) [NCV33202DMR2G](#) [M38510/13101BPA](#) [NTE925](#) [SC2904DR2G](#) [SC358DR2G](#) [LM358EDR2G](#) [AZV358MTR-G1](#)  
[AP4310AUMTR-AG1](#) [HA1630D02MMEL-E](#) [NJM358CG-TE2](#) [HA1630S01LPEL-E](#) [LM324AWPT](#) [HA1630Q06TELL-E](#) [NJM4558CG-TE2](#)  
[AZV358MMTR-G1](#) [SCY33178DR2G](#) [NCS4325DR2G](#) [LM7301SN1T1G](#) [NJU77806F3-TE1](#)