

CoolSET™-F3

ICE3A(B)0365/0565/1065/1565

ICE3A(B)2065/2565

ICE3A0565Z/2065Z

ICE3A(B)2065I/3065I/3565I

ICE3A(B)5065I/5565I

ICE3A(B)2065P/3065P/3565P

ICE3A(B)5065P/5565P

Off-Line SMPS Current Mode
Controller with integrated 650V
Startup Cell/Depletion CoolMOS™

Power Management & Supply



Never stop thinking.

Previous Version: V2.2

| Page | Subjects (major changes since last revision) |
|------|--|
| 29 | revised outline dimension for PG-DIP-8 |
| | |
| | |
| | |
| | |
| | |

For questions on technology, delivery and prices please contact the Infineon Technologies Offices in Germany or the Infineon Technologies Companies and Representatives worldwide: see our webpage at <http://www.infineon.com>

CoolMOS™, CoolSET™ are trademarks of Infineon Technologies AG.

Edition 2013-04-02

Published by
Infineon Technologies AG,
81726 Munich, Germany,
© 2012 Infineon Technologies AG.
All Rights Reserved.

Legal disclaimer

The information given in this document shall in no event be regarded as a guarantee of conditions or characteristics. With respect to any examples or hints given herein, any typical values stated herein and/or any information regarding the application of the device, Infineon Technologies hereby disclaims any and all warranties and liabilities of any kind, including without limitation, warranties of non-infringement of intellectual property rights of any third party.

Information

For further information on technology, delivery terms and conditions and prices, please contact your nearest Infineon Technologies Office (www.infineon.com).

Warnings

Due to technical requirements, components may contain dangerous substances. For information on the types in question, please contact your nearest Infineon Technologies Office.

Infineon Technologies Components may be used in life-support devices or systems only with the express written approval of Infineon Technologies, if a failure of such components can reasonably be expected to cause the failure of that life-support device or system or to affect the safety or effectiveness of that device or system. Life support devices or systems are intended to be implanted in the human body or to support and/or maintain and sustain and/or protect human life. If they fail, it is reasonable to assume that the health of the user or other persons may be endangered.

Off-Line SMPS Current Mode Controller with integrated 650V Startup Cell/ Depletion CoolMOS™

Product Highlights

- Best in class in DIP7, DIP8, TO220/I2Pak packages
- Active Burst Mode to reach the lowest Standby Power Requirements < 100mW
- Protection features (Auto Restart Mode) to increase robustness and safety of the system
- Adjustable Blanking Window for high load jumps to increase system reliability
- Isolated drain package for TO220/I2Pak
- Wide creepage distance for DIP7/TO220/I2Pak
- Wide power class of products for various applications
- Pb-free lead plating for all packages; RoHS compliant

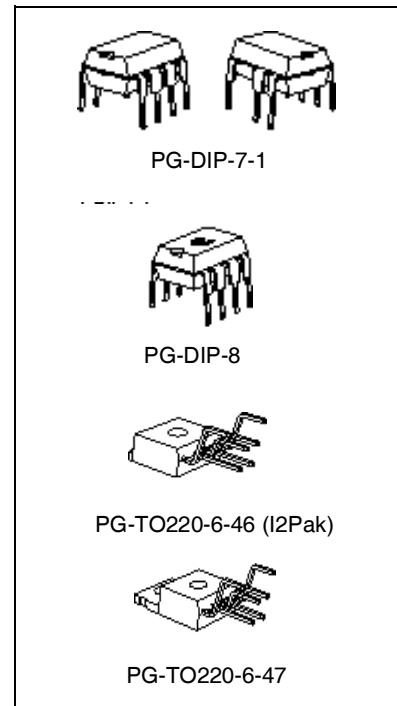

Features

- 650V avalanche rugged CoolMOS™ with built in switchable Startup Cell
- Active Burst Mode for lowest Standby Power @ light load controlled by Feedback signal
- Fast load jump response in Active Burst Mode
- 67/100 kHz fixed switching frequency
- Auto Restart Mode for Overtemperature Detection
- Auto Restart Mode for Overvoltage Detection
- Auto Restart Mode for Overload and Open Loop
- Auto Restart Mode for VCC Undervoltage
- Blanking Window for short duration high current
- User defined Soft Start
- Minimum of external components required
- Max Duty Cycle 72%
- Overall tolerance of Current Limiting < ±5%
- Internal PWM Leading Edge Blanking
- Soft driving for low EMI

Description

The new generation CoolSET™-F3 provides Active Burst Mode to reach the lowest Standby Power Requirements <100mW at no load. As the controller is always active during Active Burst Mode, there is an immediate response on load jumps without any black out in the SMPS. In Active Burst Mode the ripple of the output voltage can be reduced <1%. Furthermore, to increase the robustness and safety of the system, the device enters into Auto Restart Mode in the cases of Overtemperature, VCC Overvoltage, Output Open Loop or Overload and VCC Undervoltage. By means of the internal precise peak current limitation, the dimension of the transformer and the secondary diode can be lowered which leads to more cost efficiency. An adjustable blanking window prevents the IC from entering Auto Restart or Active Burst Mode unintentionally during high load jumps. The CoolSET™-F3 family consists a wide power class range of products for various applications.

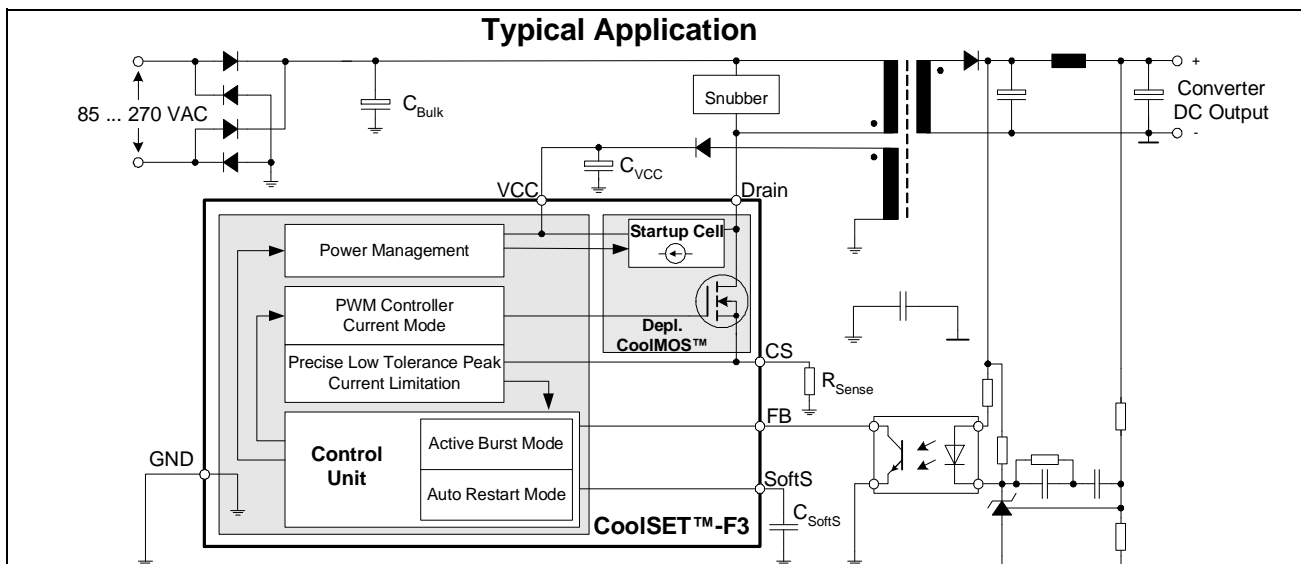

Overview

| Type | Package | V _{DS} | F _{osc} | R _{DSon} ¹⁾ | 230VAC ±15% ²⁾ | 85-265 VAC ²⁾ |
|-----------|----------|-----------------|------------------|---------------------------------|---------------------------|--------------------------|
| ICE3A0365 | PG-DIP-8 | 650V | 100kHz | 6.45 | 22W | 10W |
| ICE3A0565 | PG-DIP-8 | 650V | 100kHz | 4.70 | 25W | 12W |
| ICE3A1065 | PG-DIP-8 | 650V | 100kHz | 2.95 | 32W | 16W |
| ICE3A1565 | PG-DIP-8 | 650V | 100kHz | 1.70 | 42W | 20W |
| ICE3A2065 | PG-DIP-8 | 650V | 100kHz | 0.92 | 57W | 28W |
| ICE3A2565 | PG-DIP-8 | 650V | 100kHz | 0.65 | 68W | 33W |
| ICE3B0365 | PG-DIP-8 | 650V | 67kHz | 6.45 | 22W | 10W |
| ICE3B0565 | PG-DIP-8 | 650V | 67kHz | 4.70 | 25W | 12W |
| ICE3B1065 | PG-DIP-8 | 650V | 67kHz | 2.95 | 32W | 16W |
| ICE3B1565 | PG-DIP-8 | 650V | 67kHz | 1.70 | 42W | 20W |
| ICE3B2065 | PG-DIP-8 | 650V | 67kHz | 0.92 | 57W | 28W |
| ICE3B2565 | PG-DIP-8 | 650V | 67kHz | 0.65 | 68W | 33W |

¹⁾ typ @ T=25°C

²⁾ Calculated maximum input power rating at T_a=75°C, T_f=125°C and without copper area as heat sink.

| Type | Package | V _{DS} | F _{osc} | R _{DSon} ¹⁾ | 230VAC ±15% ²⁾ | 85-265 VAC ²⁾ |
|------------|------------|-----------------|------------------|---------------------------------|---------------------------|--------------------------|
| ICE3A0565Z | PG-DIP-7-1 | 650V | 100kHz | 4.70 | 25W | 12W |
| ICE3A2065Z | PG-DIP-7-1 | 650V | 100kHz | 0.92 | 57W | 28W |

¹⁾ typ @ T=25°C

²⁾ Calculated maximum input power rating at T_a=75°C, T_f=125°C and without copper area as heat sink.

| Type | Package | V _{DS} | F _{osc} | R _{DSon} ¹⁾ | 230VAC ±15% ²⁾ | 85-265 VAC ²⁾ |
|------------|----------------|-----------------|------------------|---------------------------------|------------------------------|--------------------------|
| ICE3A2065I | PG-TO-220-6-46 | 650V | 100kHz | 3.00 | 102W | 50W |
| ICE3A3065I | PG-TO-220-6-46 | 650V | 100kHz | 2.10 | 128W | 62W |
| ICE3A3565I | PG-TO-220-6-46 | 650V | 100kHz | 1.55 | 170W | 83W |
| ICE3A5065I | PG-TO-220-6-46 | 650V | 100kHz | 0.95 | 220W | 105W |
| ICE3A5565I | PG-TO-220-6-46 | 650V | 100kHz | 0.79 | 240W | 120W |
| ICE3B2065I | PG-TO-220-6-46 | 650V | 67kHz | 3.00 | 102W | 50W |
| ICE3B3065I | PG-TO-220-6-46 | 650V | 67kHz | 2.10 | 128W | 62W |
| ICE3B3565I | PG-TO-220-6-46 | 650V | 67kHz | 1.55 | 170W | 83W |
| ICE3B5065I | PG-TO-220-6-46 | 650V | 67kHz | 0.95 | 220W | 105W |
| ICE3B5565I | PG-TO-220-6-46 | 650V | 67kHz | 0.79 | 240W | 120W |
| ICE3A2065P | PG-TO-220-6-47 | 650V | 100kHz | 3.00 | 102W | 50W |
| ICE3A3065P | PG-TO-220-6-47 | 650V | 100kHz | 2.10 | 128W | 62W |
| ICE3A3565P | PG-TO-220-6-47 | 650V | 100kHz | 1.55 | 170W | 83W |
| ICE3A5065P | PG-TO-220-6-47 | 650V | 100kHz | 0.95 | 220W | 105W |
| ICE3A5565P | PG-TO-220-6-47 | 650V | 100kHz | 0.79 | 240W | 120W |
| ICE3B2065P | PG-TO-220-6-47 | 650V | 67kHz | 3.00 | 102W | 50W |
| ICE3B3065P | PG-TO-220-6-47 | 650V | 67kHz | 2.10 | 128W | 62W |
| ICE3B3565P | PG-TO-220-6-47 | 650V | 67kHz | 1.55 | 170W | 83W |
| ICE3B5065P | PG-TO-220-6-47 | 650V | 67kHz | 0.95 | 220W | 105W |
| ICE3B5565P | PG-TO-220-6-47 | 650V | 67kHz | 0.79 | 240W | 120W |

¹⁾ typ @ T=25°C

²⁾ Calculated maximum continuous input power in an open frame design at T_a=50°C, T_J=125°C and R_{thCA}(external heatsink)=2.7K/W

| Table of Contents | | Page |
|--------------------------|--|-------------|
| 1 | Pin Configuration and Functionality | 7 |
| 1.1 | Pin Configuration with PG-DIP-8 | 7 |
| 1.2 | Pin Configuration with PG-DIP-7-1 | 7 |
| 1.3 | Pin Configuration with PG-TO220-6-46 | 8 |
| 1.4 | Pin Configuration with PG-TO220-6-47 | 8 |
| 1.5 | Pin Functionality | 9 |
| 2 | Representative Blockdiagram | 10 |
| 3 | Functional Description | 11 |
| 3.1 | Introduction | 11 |
| 3.2 | Power Management | 11 |
| 3.3 | Startup Phase | 12 |
| 3.4 | PWM Section | 13 |
| 3.4.1 | Oscillator | 13 |
| 3.4.2 | PWM-Latch FF1 | 13 |
| 3.4.3 | Gate Driver | 13 |
| 3.5 | Current Limiting | 14 |
| 3.5.1 | Leading Edge Blanking | 14 |
| 3.5.2 | Propagation Delay Compensation | 14 |
| 3.6 | Control Unit | 15 |
| 3.6.1 | Adjustable Blanking Window | 15 |
| 3.6.2 | Active Burst Mode | 16 |
| 3.6.2.1 | Entering Active Burst Mode | 16 |
| 3.6.2.2 | Working in Active Burst Mode | 16 |
| 3.6.2.3 | Leaving Active Burst Mode | 16 |
| 3.6.3 | Protection Mode (Auto Restart Mode) | 17 |
| 4 | Electrical Characteristics | 19 |
| 4.1 | Absolute Maximum Ratings | 19 |
| 4.2 | Operating Range | 22 |
| 4.3 | Characteristics | 22 |
| 4.3.1 | Supply Section 1 | 22 |
| 4.3.2 | Supply Section 2 | 23 |
| 4.3.3 | Internal Voltage Reference | 24 |
| 4.3.4 | PWM Section | 24 |
| 4.3.5 | Control Unit | 25 |
| 4.3.6 | Current Limiting | 25 |
| 4.3.7 | CoolMOS™ Section | 26 |
| 5 | Outline Dimension | 28 |

Pin Configuration and Functionality

1 Pin Configuration and Functionality

1.1 Pin Configuration with PG-DIP-8

| Pin | Symbol | Function |
|-----|--------|--|
| 1 | SoftS | Soft-Start |
| 2 | FB | Feedback |
| 3 | CS | Current Sense/ 650V ¹⁾ Depl. CoolMOS™ Source |
| 4 | Drain | 650V ¹⁾ Depl. CoolMOS™ Drain |
| 5 | Drain | 650V ¹⁾ Depl. CoolMOS™ Drain |
| 6 | n.c. | Not Connected |
| 7 | VCC | Controller Supply Voltage |
| 8 | GND | Controller Ground |

¹⁾ at $T_j = 110^\circ\text{C}$

1.2 Pin Configuration with PG-DIP-7-1

| Pin | Symbol | Function |
|-----|--------|--|
| 1 | SoftS | Soft-Start |
| 2 | FB | Feedback |
| 3 | CS | Current Sense/ 650V ¹⁾ Depl. CoolMOS™ Source |
| 4 | n.c. | Not connected |
| 5 | Drain | 650V ¹⁾ Depl. CoolMOS™ Drain |
| - | - | - |
| 7 | VCC | Controller Supply Voltage |
| 8 | GND | Controller Ground |

¹⁾ at $T_j = 110^\circ\text{C}$

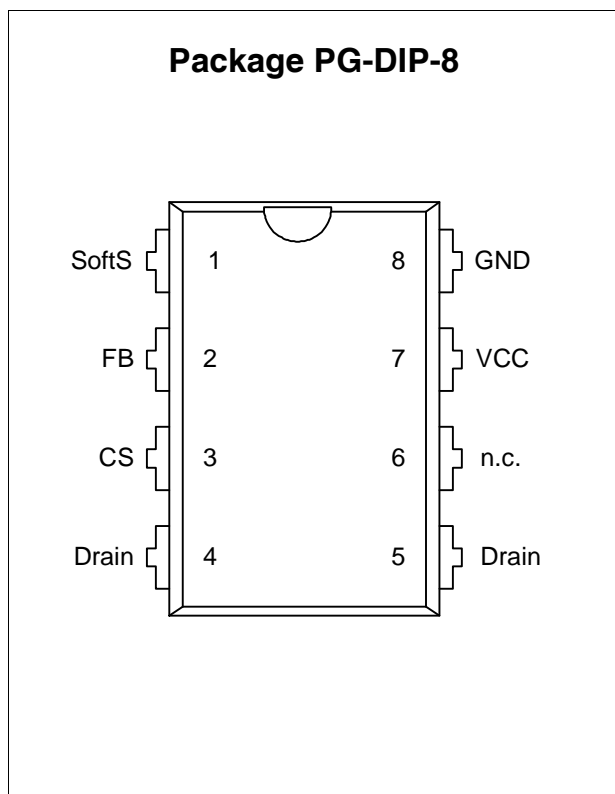

Figure 1 Pin Configuration PG-DIP-8(top view)

Note: Pin 4 and 5 are shorted within the DIP 8 package.

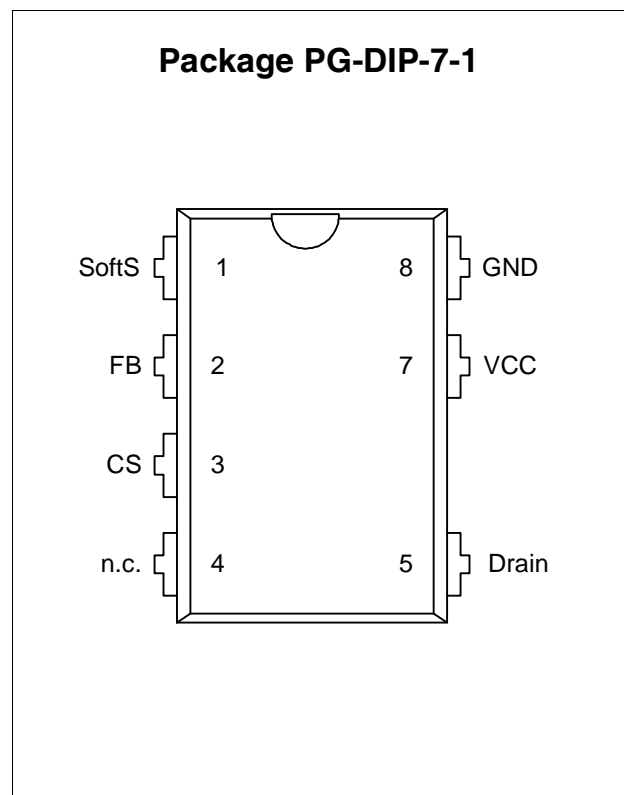

Figure 2 Pin Configuration PG-DIP-7-1(top view)

Pin Configuration and Functionality
1.3 Pin Configuration with PG-TO220-6-46

| Pin | Symbol | Function |
|-----|--------|--|
| 1 | Drain | 650V ¹⁾ Depl. CoolMOS™ Drain |
| 3 | CS | Current Sense/ 650V ¹⁾ Depl. CoolMOS™ Source |
| 4 | GND | Controller Ground |
| 5 | VCC | Controller Supply Voltage |
| 6 | SoftS | Soft-Start |
| 7 | FB | Feedback |

¹⁾ at $T_j = 110^\circ\text{C}$

1.4 Pin Configuration with PG-TO220-6-47

| Pin | Symbol | Function |
|-----|--------|--|
| 1 | Drain | 650V ¹⁾ Depl. CoolMOS™ Drain |
| 3 | CS | Current Sense/ 650V ¹⁾ Depl. CoolMOS™ Source |
| 4 | GND | Controller Ground |
| 5 | VCC | Controller Supply Voltage |
| 6 | SoftS | Soft-Start |
| 7 | FB | Feedback |

¹⁾ at $T_j = 110^\circ\text{C}$

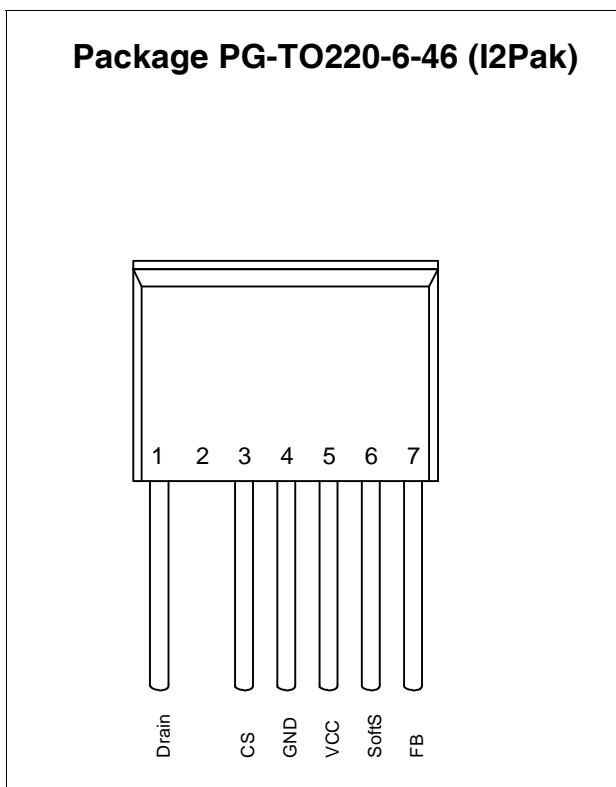

Figure 3 Pin Configuration PG-TO220-6-46 I2Pak (front view)

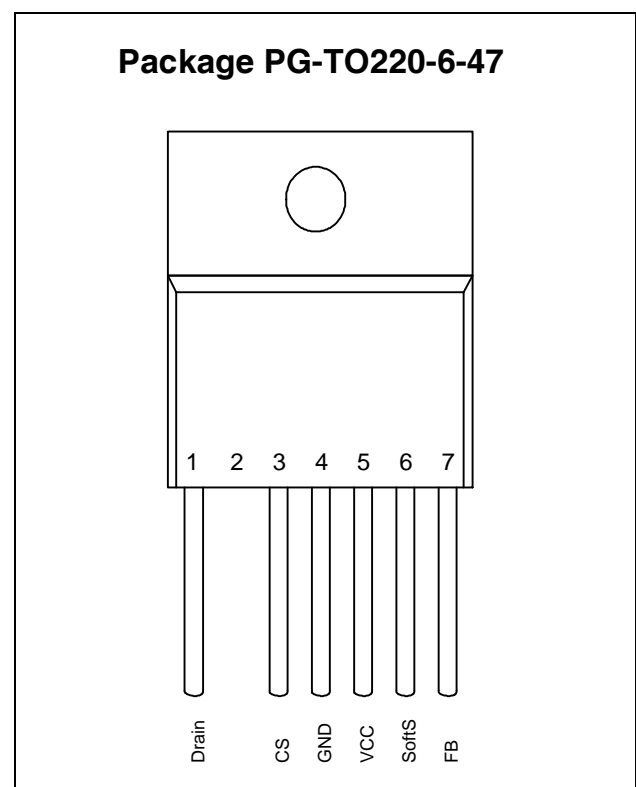

Figure 4 Pin Configuration PG-TO220-6-47 (front view)

1.5 Pin Functionality

SoftS (Soft Start & Auto Restart Control)

The SoftS pin combines the functions of Soft Start during Start Up and error detection for Auto Restart Mode. These functions are implemented and can be adjusted by means of an external capacitor at SoftS to ground. This capacitor also provides an adjustable blanking window for high load jumps, before the IC enters into Auto Restart Mode.

FB (Feedback)

The information about the regulation is provided by the FB Pin to the internal Protection Unit and to the internal PWM-Comparator to control the duty cycle. The FB-Signal controls in case of light load the Active Burst Mode of the controller.

CS (Current Sense)

The Current Sense pin senses the voltage developed on the series resistor inserted in the source of the integrated Depl. CoolMOS™. If CS reaches the internal threshold of the Current Limit Comparator, the Driver output is immediately switched off. Furthermore the current information is provided for the PWM-Comparator to realize the Current Mode.

Drain (Drain of integrated Depl. CoolMOS™)

Pin Drain is the connection to the Drain of the internal Depl. CoolMOS™.

VCC (Power supply)

The VCC pin is the positive supply of the IC. The operating range is between 8.5V and 21V.

GND (Ground)

The GND pin is the ground of the controller.

3 Functional Description

All values which are used in the functional description are typical values. For calculating the worst cases the min/max values which can be found in section 4 Electrical Characteristics have to be considered.

3.1 Introduction

CoolSET™-F3 is the further development of the CoolSET™-F2 to meet the requirements for the lowest Standby Power at minimum load and no load conditions. A new fully integrated Standby Power concept is implemented into the IC in order to keep the application design easy. Compared to CoolSET™-F2 no further external parts are needed to achieve the lowest Standby Power. An intelligent Active Burst Mode is used for this Standby Mode. After entering this mode there is still a full control of the power conversion by the secondary side via the same optocoupler that is used for the normal PWM control. The response on load jumps is optimized. The voltage ripple on V_{out} is minimized. V_{out} is further on well controlled in this mode.

The usually external connected RC-filter in the feedback line after the optocoupler is integrated in the IC to reduce the external part count.

Furthermore a high voltage Startup Cell is integrated into the IC which is switched off once the Undervoltage Lockout on-threshold of 15V is exceeded. This Startup Cell is part of the integrated Depl. CoolMOS™. The external startup resistor is no longer necessary as this Startup Cell is connected to the Drain. Power losses are therefore reduced. This increases the efficiency under light load conditions drastically.

The Soft-Start capacitor is also used for providing an adjustable blanking window for high load jumps. During this time window the overload detection is disabled. With this concept no further external components are necessary to adjust the blanking window.

An Auto Restart Mode is implemented in the IC to reduce the average power conversion in the event of malfunction or unsafe operating condition in the SMPS system. This feature increases the system's robustness and safety which would otherwise lead to a destruction of the SMPS. Once the malfunction is removed, normal operation is automatically initiated after the next Start Up Phase.

The internal precise peak current limitation reduces the costs for the transformer and the secondary diode. The influence of the change in the input voltage on the power limitation can be avoided together with the integrated Propagation Delay Compensation. Therefore the maximum power is nearly independent on the input voltage which is required for wide range SMPS. There is no need for an extra over-sizing of the SMPS, e.g. the transformer or the secondary diode.

3.2 Power Management

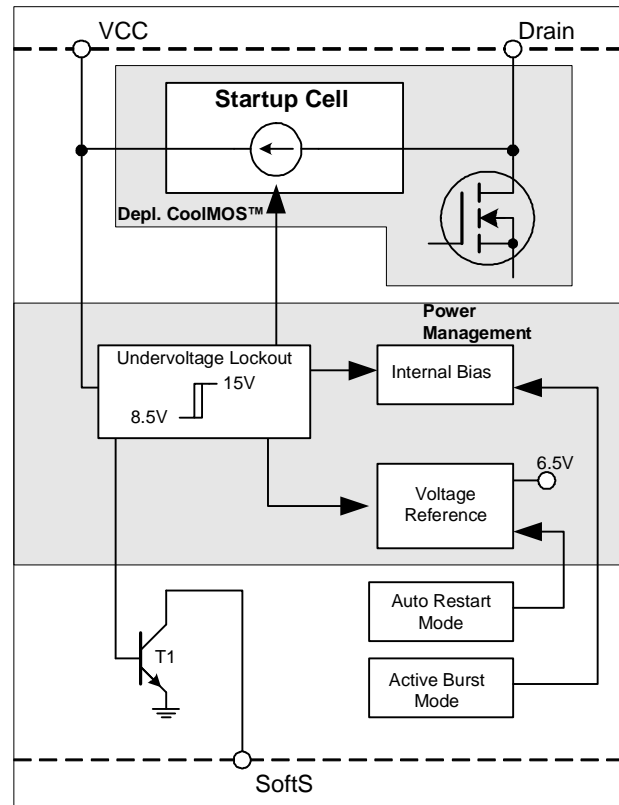

Figure 6 Power Management

The Undervoltage Lockout monitors the external supply voltage V_{VCC} . When the SMPS is plugged to the main line the internal Startup Cell is biased and starts to charge the external capacitor C_{VCC} which is connected to the VCC pin. This VCC charge current which is provided by the Startup Cell from the Drain pin is 1.05mA. When V_{VCC} exceeds the on-threshold $V_{CCon}=15V$ the internal voltage reference and bias circuit are switched on. Then the Startup Cell is switched off by the Undervoltage Lockout and therefore no power losses present due to the connection of the Startup Cell to the Drain voltage. To avoid uncontrolled ringing at switch-on a hysteresis is implemented. The switch-off of the controller can only take place after Active Mode was entered and V_{VCC} falls below 8.5V.

The maximum current consumption before the controller is activated is about 160 μ A.

When V_{VCC} falls below the off-threshold $V_{CCoff}=8.5V$ the internal reference is switched off and the Power Down reset let T1 discharging the soft-start capacitor C_{SoftS} at pin SoftS. Thus it is ensured that at every startup cycle the voltage ramp at pin SoftS starts at zero.

Functional Description

The internal Voltage Reference is switched off if Auto Restart Mode is entered. The current consumption is then reduced to 300µA.

Once the malfunction condition is removed, this block will then turn back on. The recovery from Auto Restart Mode does not require disconnecting the SMPS from the AC line.

When Active Burst Mode is entered, the internal Bias is switched off in order to reduce the current consumption to below 1.05mA while keeping the Voltage Reference active as this is necessary in this mode.

DC_{max} which is controlled by comparator C7 since comparator C2 blocks the gate G7 (see Figure 7). This maximum charge current in the very first stage when V_{SoftS} is below 1V, is limited to 1.32mA.

3.3 Startup Phase

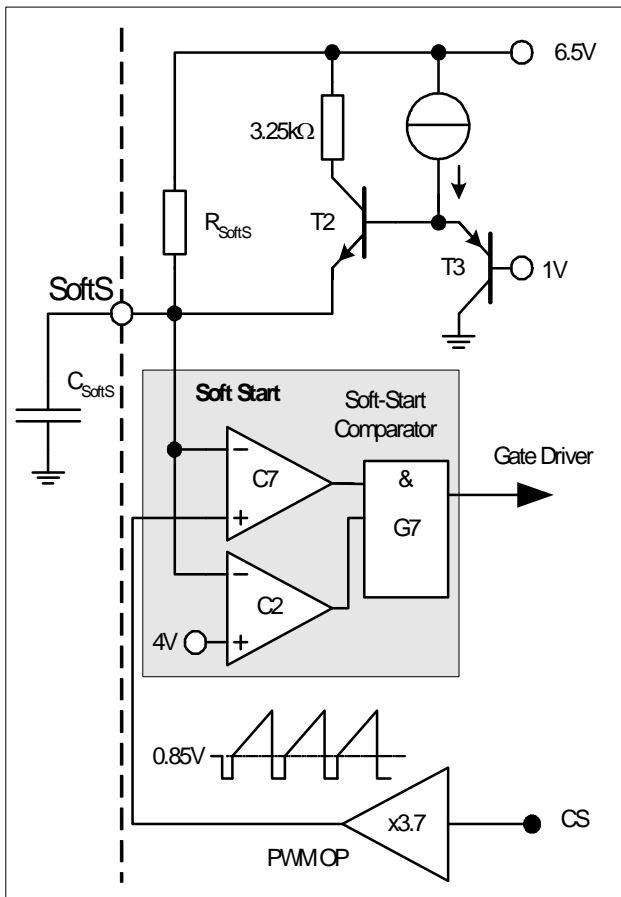

Figure 7 Soft Start

At the beginning of the Startup Phase, the IC provides a Soft Start duration whereby it controls the maximum primary current by means of a duty cycle limitation. A signal V_{SoftS} which is generated by the external capacitor C_{SoftS} in combination with the internal pull up resistor R_{SoftS} , determines the duty cycle until V_{SoftS} exceeds 4V.

When the Soft Start begins, C_{SoftS} is immediately charged up to approx. 1V by T2. Therefore the Soft Start Phase takes place between 1V and 4V. Above $V_{SoftS} = 4V$ there is no longer duty cycle limitation

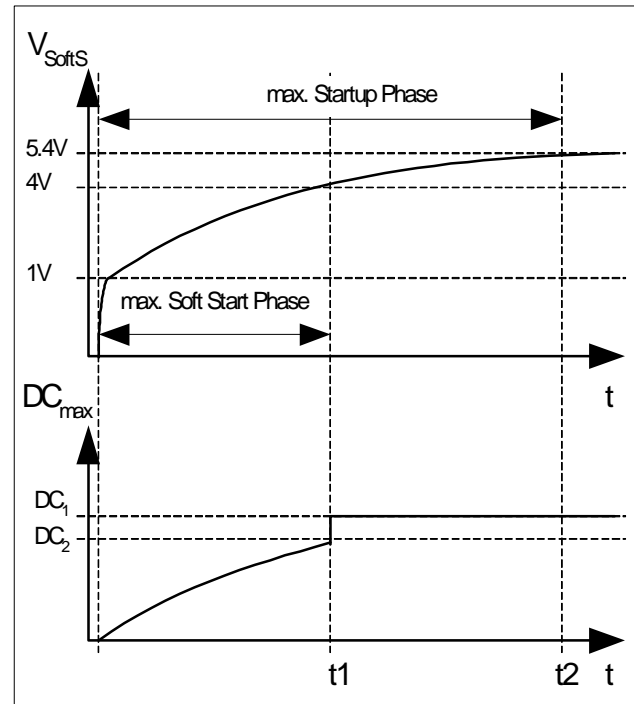

Figure 8 Startup Phase

By means of this extra charge stage, there is no delay in the beginning of the Startup Phase when there is still no switching. Furthermore Soft Start is finished at 4V to have faster the maximum power capability. The duty cycles DC_1 and DC_2 are depending on the mains and the primary inductance of the transformer. The limitation of the primary current by DC_2 is related to $V_{SoftS} = 4V$. But DC_1 is related to a maximum primary current which is limited by the internal Current Limiting with $CS = 1V$. Therefore the maximum Startup Phase is divided into a Soft Start Phase until $t1$ and a phase from $t1$ until $t2$ where maximum power is provided if demanded by the FB signal.

Functional Description
3.4 PWM Section

Figure 9 PWM Section

3.4.1 Oscillator

The oscillator generates a fixed frequency. The switching frequency of ICE3Axx65x is $f_{OSC} = 100\text{kHz}$ and for ICE3Bxx65x $f_{OSC} = 67\text{kHz}$. A resistor, a capacitor and a current source and current sink which determine the frequency are integrated. The charging and discharging current of the implemented oscillator capacitor are internally trimmed, in order to achieve a very accurate switching frequency. The ratio of controlled charge to discharge current is adjusted to reach a maximum duty cycle limitation of $D_{max}=0.72$.

3.4.2 PWM-Latch FF1

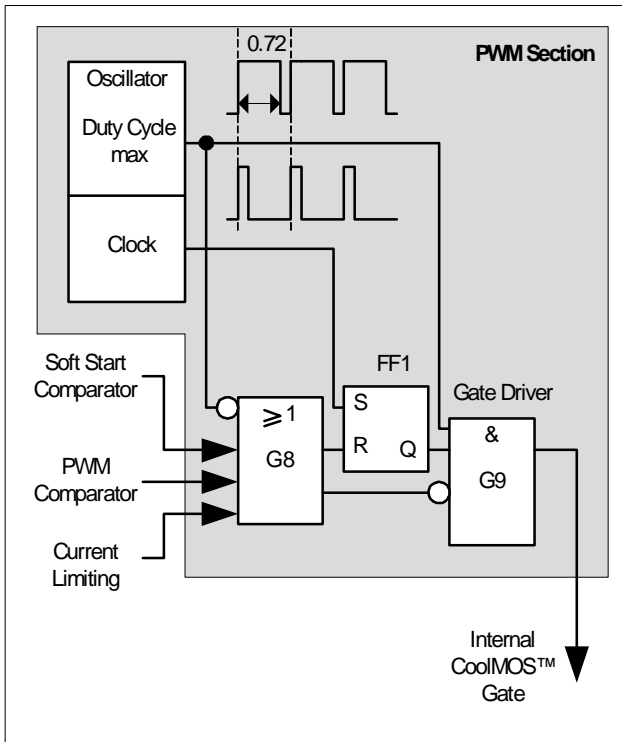
The oscillator clock output provides a set pulse to the PWM-Latch when initiating the internal CoolMOS™ conduction. After setting the PWM-Latch can be reset by the PWM comparator, the Soft Start comparator or the Current-Limit comparator. In case of resetting, the driver is shut down immediately.

3.4.3 Gate Driver

Figure 10 Gate Driver

The driver-stage is optimized to minimize EMI and to provide high circuit efficiency. This is done by reducing the switch on slope when exceeding the internal CoolMOS™ threshold. This is achieved by a slope control of the rising edge at the driver's output (see Figure 11).

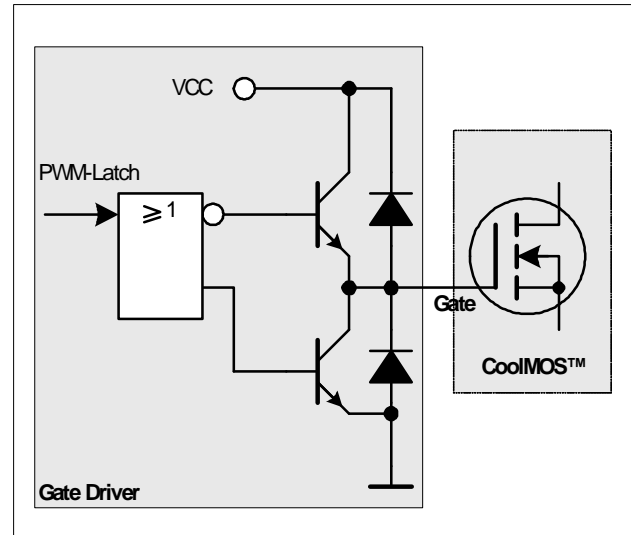
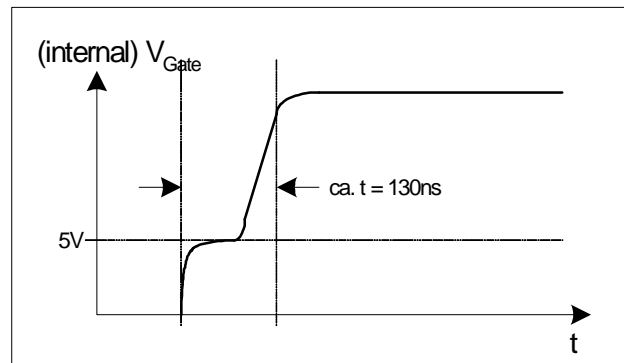

Figure 11 Gate Rising Slope

Thus the leading switch on spike is minimized. When the integrated CoolMOS™ is switched off, the falling shape of the driver is slowed down when reaching 2V to prevent an overshoot below ground. Furthermore the driver circuit is designed to eliminate cross conduction of the output stage.

During powerup when VCC is below the undervoltage lockout threshold V_{VCCoff} , the output of the Gate Driver is low to disable power transfer to the seconding side.

3.5 Current Limiting

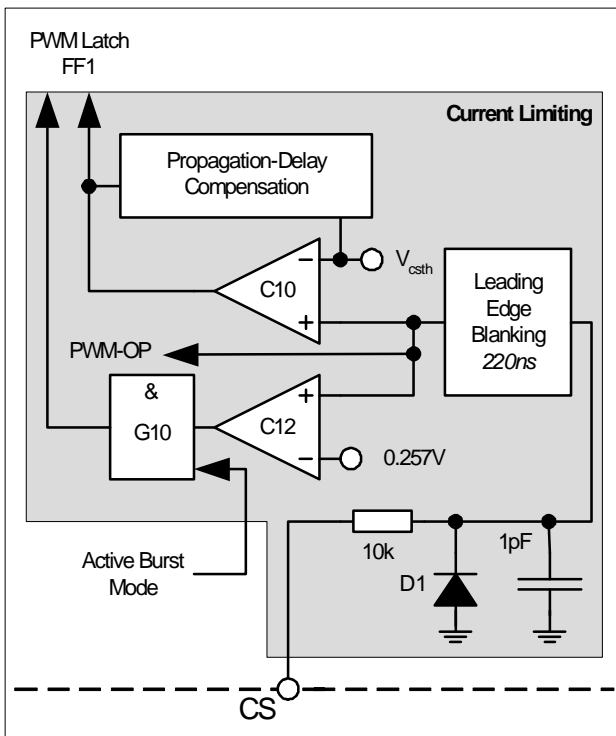

Figure 12 Current Limiting Block

There is a cycle by cycle Current Limiting realized by the Current-Limit comparator C10 to provide an overcurrent detection. The source current of the internal CoolMOS™ is sensed via an external sense resistor R_{Sense} . By means of R_{Sense} the source current is transformed to a sense voltage V_{Sense} which is fed into the pin CS. If the voltage V_{Sense} exceeds the internal threshold voltage V_{csth} the comparator C10 immediately turns off the gate drive by resetting the PWM Latch FF1. A Propagation Delay Compensation is added to support the immediate shut down without delay of the internal CoolMOS™ in case of Current Limiting. The influence of the AC input voltage on the maximum output power can thereby be avoided.

To prevent the Current Limiting from distortions caused by leading edge spikes a Leading Edge Blanking is integrated in the current sense path for the comparators C10, C12 and the PWM-OP.

The output of comparator C12 is activated by the Gate G10 if Active Burst Mode is entered. Once activated the current limiting is thereby reduced to 0.257V. This voltage level determines the power level when the Active Burst Mode is left if there is a higher power demand.

3.5.1 Leading Edge Blanking

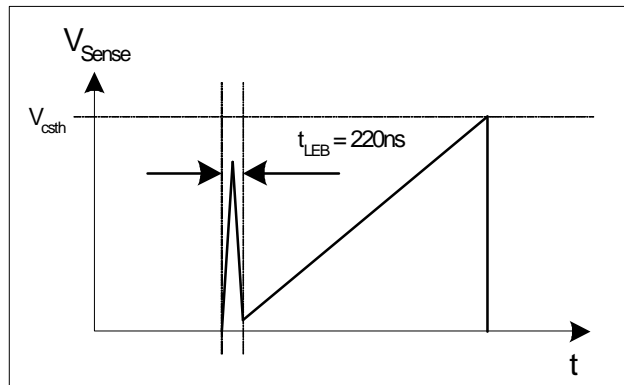

Figure 13 Leading Edge Blanking

Each time when the internal CoolMOS™ is switched on, a leading edge spike is generated due to the primary-side capacitances and secondary-side rectifier reverse recovery time. This spike can cause the gate drive to switch off unintentionally. To avoid a premature termination of the switching pulse, this spike is blanked out with a time constant of $t_{LEB} = 220\text{ns}$. During this time, the gate drive will not be switched off.

3.5.2 Propagation Delay Compensation

In case of overcurrent detection, the switch-off of the internal CoolMOS™ is delayed due to the propagation delay of the circuit. This delay causes an overshoot of the peak current I_{peak} which depends on the ratio of dI/dt of the peak current (see Figure 14).

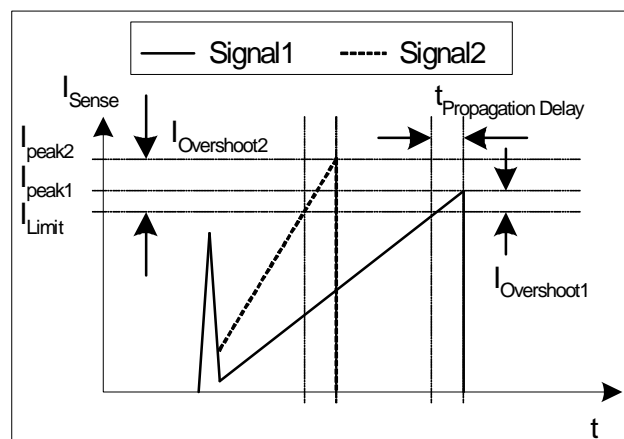

Figure 14 Current Limiting

The overshoot of Signal2 is bigger than of Signal1 due to the steeper rising waveform. This change in the slope is depending on the AC input voltage. Propagation Delay Compensation is integrated to limit the overshoot dependency on dI/dt of the rising primary current. That means the propagation delay time between exceeding the current sense threshold V_{csth} and the switch off of the internal CoolMOS™ is compensated over temperature within a wide range.

Functional Description

Current Limiting is now possible in a very accurate way. E.g. $I_{peak} = 0.5A$ with $R_{Sense} = 2$. Without Propagation Delay Compensation the current sense threshold is set to a static voltage level $V_{csth} = 1V$. A current ramp of $dI/dt = 0.4A/\mu s$, that means $dV_{Sense}/dt = 0.8V/\mu s$, and a propagation delay time of i.e. $t_{Propagation\ Delay} = 180ns$ leads then to an I_{peak} overshoot of 14.4%. By means of propagation delay compensation the overshoot is only about 2% (see Figure 15).

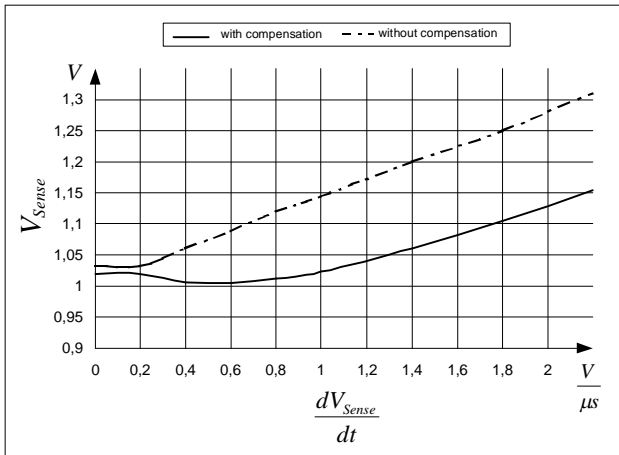

Figure 15 Overcurrent Shutdown

The Propagation Delay Compensation is realized by means of a dynamic threshold voltage V_{csth} (see Figure 16). In case of a steeper slope the switch off of the driver is earlier to compensate the delay.

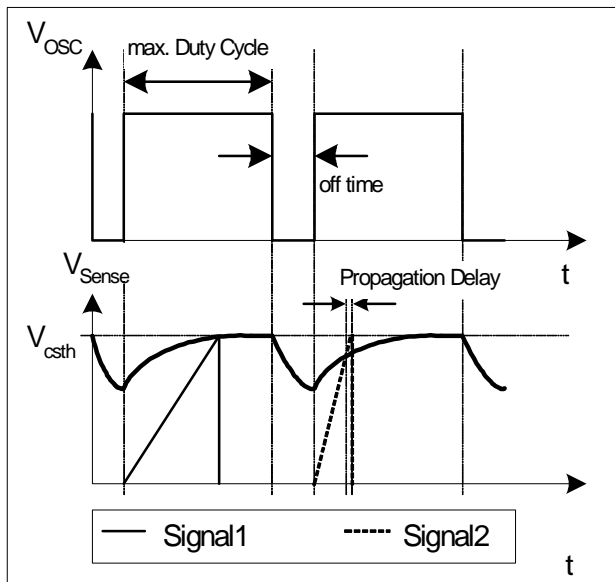

Figure 16 Dynamic Voltage Threshold V_{csth}

3.6 Control Unit

The Control Unit contains the functions for Active Burst Mode and Auto Restart Mode. The Active Burst Mode and the Auto Restart Mode are combined with an Adjustable Blanking Window which is depending on the external Soft Start capacitor. By means of this Adjustable Blanking Window, the IC avoids entering into these two modes accidentally. Furthermore it also provides a certain time whereby the overload detection is delayed. This delay is useful for applications which normally works with a low current and occasionally require a short duration of high current.

3.6.1 Adjustable Blanking Window

Figure 17 Adjustable Blanking Window

V_{SoftS} is clamped at 4.4V by the closed switch S1 after the SMPS is settled. If overload occurs V_{FB} is exceeding 4.8V. Auto Restart Mode can't be entered as the gate G5 is still blocked by the comparator C3. But after V_{FB} has exceeded 4.8V the switch S1 is opened

Functional Description

via the gate G2. The external Soft Start capacitor can now be charged further by the integrated pull up resistor R_{SoftS} . The comparator C3 releases the gates G5 and G6 once V_{SoftS} has exceeded 5.4V. Therefore there is no entering of Auto Restart Mode possible during this charging time of the external capacitor C_{SoftS} . The same procedure happens to the external Soft Start capacitor if a low load condition is detected by comparator C5 when V_{FB} is falling below 1.32V. Only after V_{SoftS} has exceeded 5.4V and V_{FB} is still below 1.32V Active Burst Mode is entered.

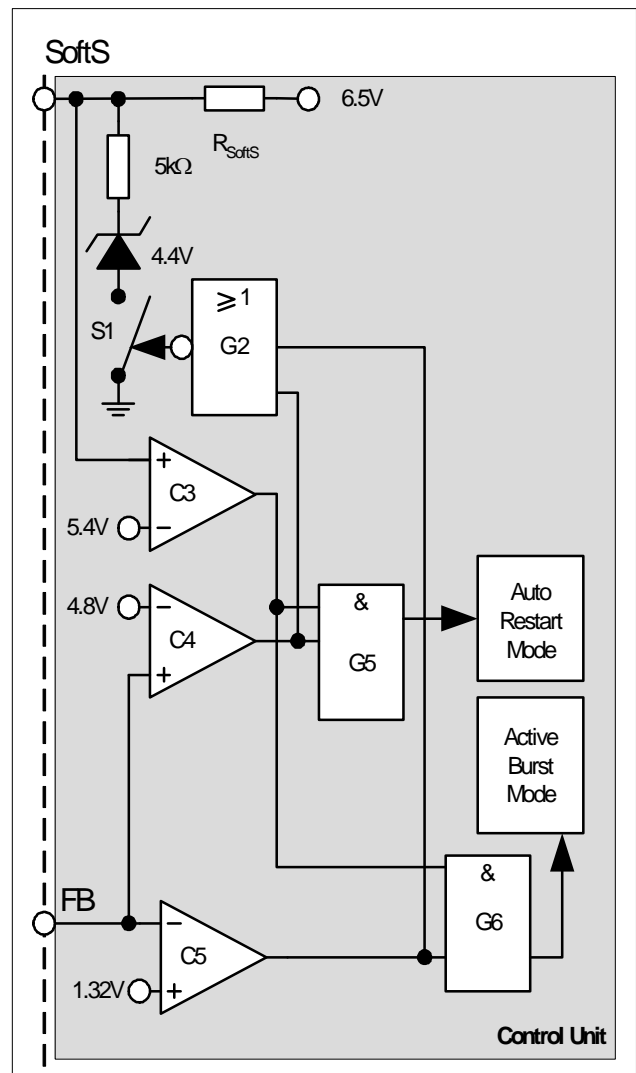
3.6.2 Active Burst Mode

The controller provides Active Burst Mode for low load conditions at V_{OUT} . Active Burst Mode increases significantly the efficiency at light load conditions while supporting a low ripple on V_{OUT} and fast response on load jumps. During Active Burst Mode which is controlled only by the FB signal the IC is always active and can therefore immediately response on fast changes at the FB signal. The Startup Cell is kept switched off to avoid increased power losses for the self supply.

The Active Burst Mode is located in the Control Unit. Figure 18 shows the related components.

3.6.2.1 Entering Active Burst Mode

The FB signal is always observed by the comparator C5 if the voltage level falls below 1.32V. In that case the switch S1 is released which allows the capacitor C_{SoftS} to be charged starting from the clamped voltage level at 4.4V in normal operating mode. If V_{SoftS} exceeds 5.4V the comparator C3 releases the gate G6 to enter the Active Burst Mode. The time window that is generated by combining the FB and SoftS signals with gate G6 avoids a sudden entering of the Active Burst Mode due to large load jumps. This time window can be adjusted by the external capacitor C_{SoftS} .

After entering Active Burst Mode a burst flag is set and the internal bias is switched off in order to reduce the current consumption of the IC down to approx. 1.05mA. In this Off State Phase the IC is no longer self supplied so that therefore C_{VCC} has to provide the VCC current (see Figure 19). Furthermore gate G11 is then released to start the next burst cycle once V_{FB} has 3.4V exceeded.

It has to be ensured by the application that the VCC remains above the Undervoltage Lockout Level of 8.5V to avoid that the Startup Cell is accidentally switched on. Otherwise power losses are significantly increased. The minimum VCC level during Active Burst Mode is depending on the load conditions and the application. The lowest VCC level is reached at no load conditions at V_{OUT} .

3.6.2.2 Working in Active Burst Mode

After entering the Active Burst Mode the FB voltage rises as V_{OUT} starts to decrease due to the inactive PWM section. Comparator C6a observes the FB signal if the voltage level 4V is exceeded. In that case the internal circuit is again activated by the internal Bias to start with switching. As now in Active Burst Mode the gate G10 is released the current limit is only 0.257V to reduce the conduction losses and to avoid audible noise. If the load at V_{OUT} is still below the starting level for the Active Burst Mode the FB signal decreases down to 3.4V. At this level C6b deactivates again the internal circuit by switching off the internal Bias. The gate G11 is released as after entering Active Burst Mode the burst flag is set. If working in Active Burst Mode the FB voltage is changing like a saw tooth between 3.4V and 4V (see Figure 19).

3.6.2.3 Leaving Active Burst Mode

The FB voltage immediately increases if there is a high load jump. This is observed by comparator C4. As the current limit is ca. 26% during Active Burst Mode a certain load jump is needed that FB can exceed 4.8V. At this time C4 resets the Active Burst Mode which also

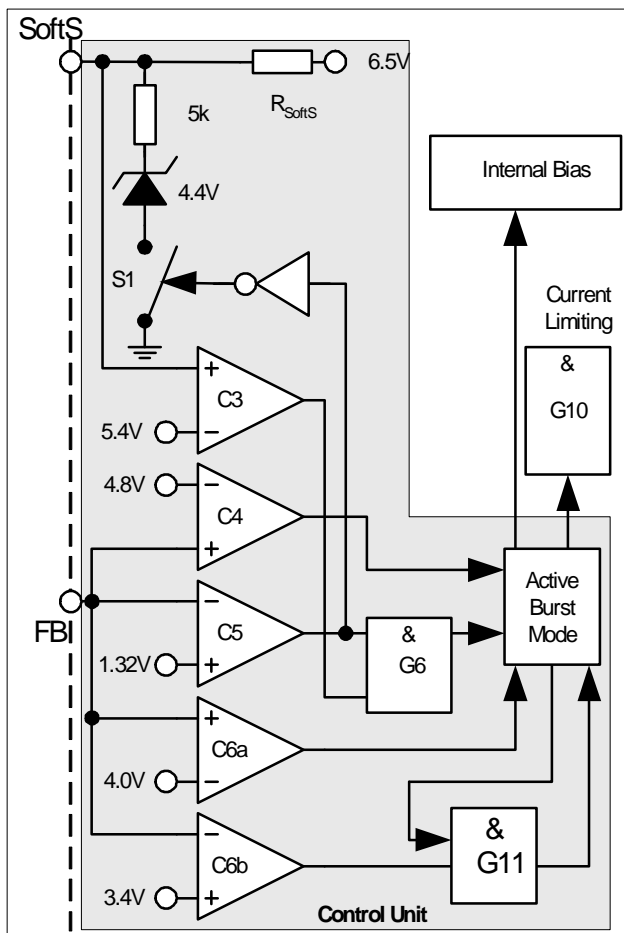

Figure 18 Active Burst Mode

Functional Description

blocks C12 by the gate G10. Maximum current can now be provided to stabilize V_{OUT} .

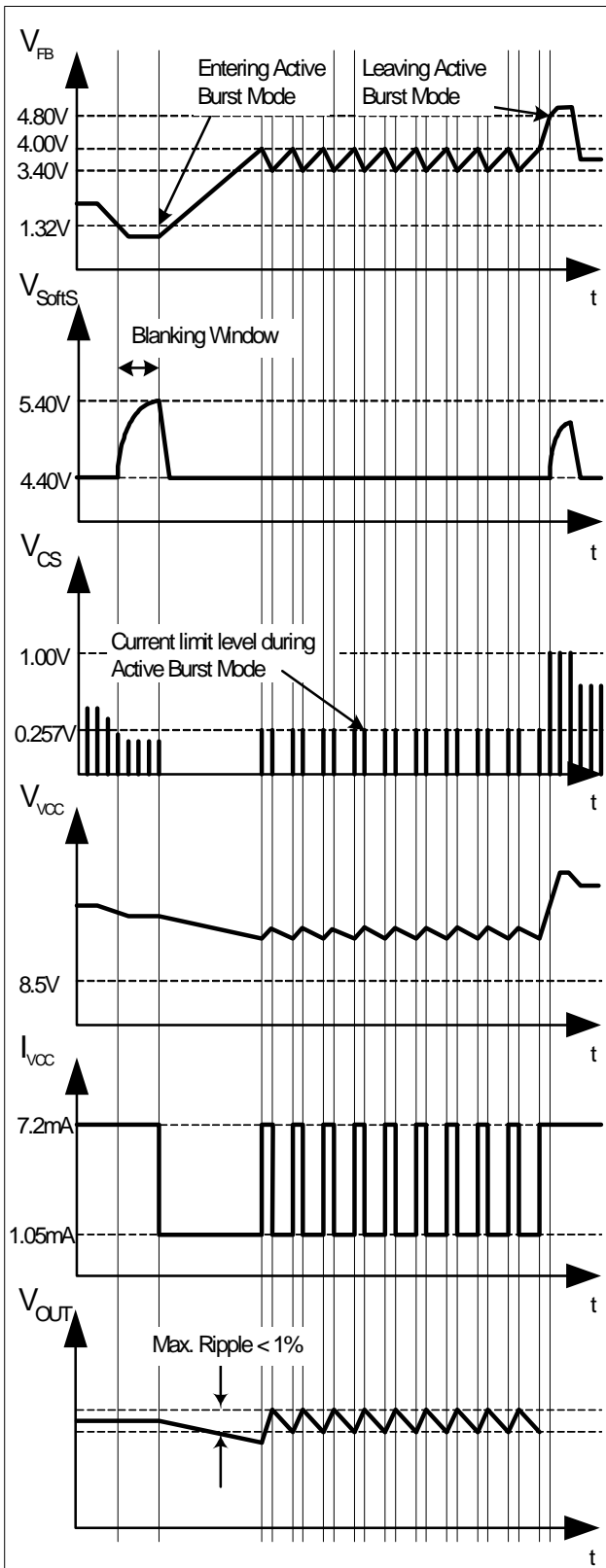

Figure 19 Signals in Active Burst Mode

3.6.3 Protection Mode (Auto Restart Mode)

In order to increase the SMPS system's robustness and safety, the IC provides the Auto Restart Mode as a protection feature. The Auto Restart Mode is entered upon detection of the following faults in the system:

- VCC Overvoltage
- Overtemperature
- Overload
- Open Loop
- VCC Undervoltage
- Short Optocoupler

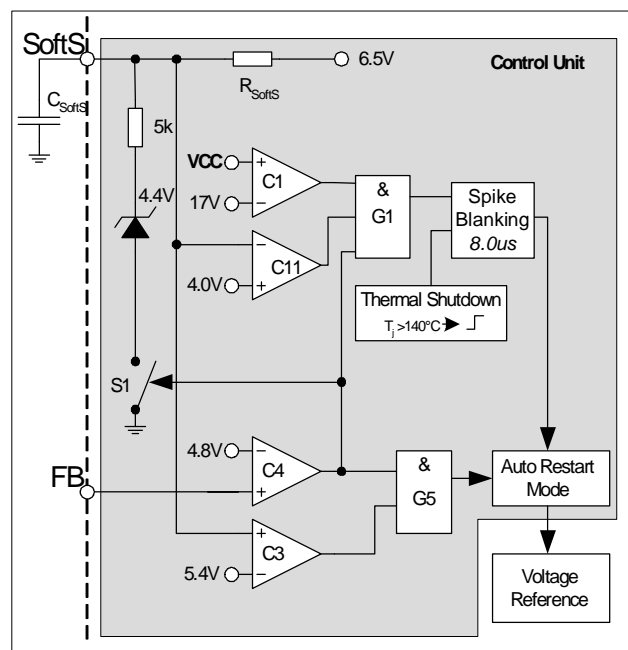

Figure 20 Auto Restart Mode

The VCC voltage is observed by comparator C1 if 17V is exceeded. The output of C1 is combined with both the output of C11 which checks for $SoftSt < 4.0V$, and the output of C4 which checks for $FB > 4.8V$. Therefore the overvoltage detection is can only active during Soft Start Phase ($SoftSt < 4.0V$) and when FB signal is outside the operating range $> 4.8V$. This means any small voltage overshoots of V_{VCC} during normal operating cannot trigger the Auto Restart Mode.

In order to ensure system reliability and prevent any false activation, a blanking time is implemented before the IC can enter into the Auto Restart Mode. The output of the VCC overvoltage detection is fed into a spike blanking with a time constant of $8.0\mu s$.

The other fault detection which can result in the Auto Restart Mode and has this $8.0\mu s$ blanking time is the Overtemperature detection. This block checks for a junction temperature of higher than $140^\circ C$ for malfunction operation.

Functional Description

Once the Auto Restart Mode is entered, the internal Voltage Reference is switched off in order to reduce the current consumption of the IC as much as possible. In this mode, the average current consumption is only 300µA as the only working block is the Undervoltage Lockout(UVLO) which controls the Startup Cell by switching on/off at V_{VCCOn}/V_{VCCOff} .

As there is no longer a self supply by the auxiliary winding, VCC starts to drop. The UVLO switches on the integrated Startup Cell when VCC falls below 8.5V. It will continue to charge VCC up to 15V whereby it is switched off again and the IC enters into the Start Up Phase.

As long as all fault conditions have been removed, the IC will automatically power up as usual with switching cycle at the GATE output after Soft Start duration. Thus the name Auto Restart Mode.

Other fault detections which are active in normal operation is the sensing for Overload, Open Loop and VCC undervoltage conditions. In the first 2 cases, FB will rise above 4.8V which will be observed by C4. At this time, S1 is released such that V_{SoftS} can rise from its earlier clamp voltage of 4.4V. If V_{SoftS} exceeds 5.4V which is observed by C3, Auto Restart Mode is entered as both inputs of the gate G5 are high.

This charging of the Soft Start capacitor from 4.4V to 5.4V defines a blanking window which prevents the system from entering into Auto Restart Mode unintentionally during large load jumps. In this event, FB will rise close to 6.5V for a short duration before the loop regulates with FB less than 4.8V. This is the same blanking time window as for the Active Burst Mode and can therefore be adjusted by the external C_{SoftS} .

In the case of VCC undervoltage, ie. VCC falls below 8.5V, the IC will be turn off with the Startup Cell charging VCC as described earlier in this section. Once VCC is charged above 15V, the IC will start a new startup cycle. The same procedure applies when the system is under Short Optocoupler fault condition, as it will lead to VCC undervoltage.

Electrical Characteristics

4 Electrical Characteristics

Note: All voltages are measured with respect to ground (Pin 8). The voltage levels are valid if other ratings are not violated.

4.1 Absolute Maximum Ratings

Note: Absolute maximum ratings are defined as ratings, which when being exceeded may lead to destruction of the integrated circuit. For the same reason make sure, that any capacitor that will be connected to pin 7 (VCC) is discharged before assembling the application circuit.

| Parameter | Symbol | Limit Values | | Unit | Remarks |
|--|--------------------------|-----------------|------|------|---------------------------|
| | | min. | max. | | |
| Drain Source Voltage ICE3Axx65/xx65I/xx65P ICE3Bxx65/xx65I/xx65P | V_{DS} | - | 650 | V | $T_j=110^{\circ}\text{C}$ |
| Pulse drain current, I_{Dp} limited by max. $T_j=150^{\circ}\text{C}$ | ICE3x0365 | I_{D_Puls1} | - | 1.6 | A |
| | ICE3x0565 ICE3A0565Z | I_{D_Puls2} | - | 2.3 | A |
| | ICE3x1065 | I_{D_Puls3} | - | 3.4 | A |
| | ICE3x1565 | I_{D_Puls4} | - | 6.1 | A |
| | ICE3x2065 ICE3A2065Z | I_{D_Puls5} | - | 10.3 | A |
| | ICE3x2565 | I_{D_Puls6} | - | 15.7 | A |
| | ICE3x2065I ICE3x2065P | I_{D_Puls7} | - | 3.4 | A |
| | ICE3x3065I ICE3x3065P | I_{D_Puls8} | - | 4.3 | A |
| | ICE3x3565I ICE3x3565P | I_{D_Puls9} | - | 6.5 | A |
| | ICE3x5065I ICE3x5065P | I_{D_Puls10} | - | 9.4 | A |
| | ICE3x5565I ICE3x5565P | I_{D_Puls11} | - | 10.7 | A |

Electrical Characteristics

| Parameter | Symbol | Limit Values | | Unit | Remarks |
|--|--------------------------|--------------|------|-------|---------|
| | | min. | max. | | |
| Avalanche energy, repetitive t_{AR} limited by max. $T_j=150^{\circ}\text{C}^1)$ | ICE3x0365 | E_{AR1} | - | 0.005 | mJ |
| | ICE3x0565 ICE3A0565Z | E_{AR2} | - | 0.01 | mJ |
| | ICE3x1065 | E_{AR3} | - | 0.07 | mJ |
| | ICE3x1565 | E_{AR4} | - | 0.15 | mJ |
| | ICE3x2065 ICE3A2065Z | E_{AR5} | - | 0.40 | mJ |
| | ICE3x2565 | E_{AR6} | - | 0.47 | mJ |
| | ICE3x2065I ICE3x2065P | E_{AR7} | - | 0.07 | mJ |
| | ICE3x3065I ICE3x3065P | E_{AR8} | - | 0.11 | mJ |
| | ICE3x3565I ICE3x3565P | E_{AR9} | - | 0.17 | mJ |
| | ICE3x5065I ICE3x5065P | E_{AR10} | - | 0.40 | mJ |
| | ICE3x5565I ICE3x5565P | E_{AR11} | - | 0.44 | mJ |

Electrical Characteristics

| Parameter | Symbol | Limit Values | | Unit | Remarks | |
|--|--------------------------|--------------|------|------|---------|--|
| | | min. | max. | | | |
| Avalanche current, repetitive t_{AR} limited by max. $T_j=150^\circ\text{C}$ | ICE3x0365 | I_{AR1} | - | 0.3 | A | |
| | ICE3x0565 ICE3A0565Z | I_{AR2} | - | 0.5 | A | |
| | ICE3x1065 | I_{AR3} | - | 1.0 | A | |
| | ICE3x1565 | I_{AR4} | - | 1.5 | A | |
| | ICE3x2065 ICE3A2065Z | I_{AR5} | - | 2.0 | A | |
| | ICE3x2565 | I_{AR6} | - | 2.5 | A | |
| | ICE3x2065I ICE3x2065P | I_{AR7} | - | 2.0 | A | |
| | ICE3x3065I ICE3x3065P | I_{AR8} | - | 3.0 | A | |
| | ICE3x3565I ICE3x3565P | I_{AR9} | - | 3.5 | A | |
| | ICE3x5065I ICE3x5065P | I_{AR10} | - | 5.0 | A | |
| | ICE3x5565I ICE3x5565P | I_{AR11} | - | 5.5 | A | |

1) Repetitive avalanche causes additional power losses that can be calculated as $P_{AV}=E_{AR} \cdot f$

Electrical Characteristics

| Parameter | Symbol | Limit Values | | Unit | Remarks | |
|-------------------------------------|--|--------------|------|------|--------------------------------|---|
| | | min. | max. | | | |
| Thermal Resistance Junction-Ambient | ICE3x0365 ICE3x0565 ICE3x1065 ICE3x1565 ICE3x2065 ICE3x2565 | R_{thJA1} | | 90 | K/W | PG-DIP-8 |
| | ICE3A0565Z ICE3x2065Z | R_{thJA2} | | 96 | K/W | PG-DIP-7-1 |
| | ICE3x2065I ICE3x3065I ICE3x3565I ICE3x5065I ICE3x5565I | R_{thJA3} | | 103 | K/W | PG-TO220-6-46 Free standing without heatsink |
| | ICE3x2065P ICE3x3065P ICE3x3565P ICE3x5065P ICE3x5565P | R_{thJA4} | | 82 | K/W | PG-TO220-6-47 Free standing without heatsink |
| Thermal Resistance Junction-Case | ICE3x2065I ICE3x2065P | R_{thJC1} | | 3.30 | K/W | PG-TO220-6-46 PG-TO220-6-47 |
| | ICE3x3065I ICE3x3065P | R_{thJC2} | | 3.08 | K/W | PG-TO220-6-46 PG-TO220-6-47 |
| | ICE3x3565I ICE3x3565P | R_{thJC3} | | 2.94 | K/W | PG-TO220-6-46 PG-TO220-6-47 |
| | ICE3x5065I ICE3x5065P | R_{thJC4} | | 2.79 | K/W | PG-TO220-6-46 PG-TO220-6-47 |
| | ICE3x5565I ICE3x5565P | R_{thJC5} | | 2.75 | K/W | PG-TO220-6-46 PG-TO220-6-47 |
| VCC Supply Voltage | V_{VCC} | -0.3 | 22 | V | | |
| FB Voltage | V_{FB} | -0.3 | 6.5 | V | | |
| SoftS Voltage | V_{SoftS} | -0.3 | 6.5 | V | | |
| CS Voltage | V_{CS} | -0.3 | 6.5 | V | | |
| Junction Temperature | T_j | -40 | 150 | °C | Controller & CoolMOS™ | |
| Storage Temperature | T_s | -55 | 150 | °C | | |
| ESD Capability(incl. Drain Pin) | V_{ESD} | - | 3 | kV | Human body model ¹⁾ | |

¹⁾ According to EIA/JESD22-A114-B (discharging a 100pF capacitor through a 1.5kΩ series resistor)

Electrical Characteristics

4.2 Operating Range

Note: Within the operating range the IC operates as described in the functional description.

| Parameter | Symbol | Limit Values | | Unit | Remarks |
|------------------------------------|----------------|--------------|------|------|--|
| | | min. | max. | | |
| VCC Supply Voltage | V_{VCC} | V_{VCCoff} | 21 | V | |
| Junction Temperature of Controller | T_{JCon} | -25 | 130 | °C | Max value limited due to thermal shut down of controller |
| Junction Temperature of CoolMOS™ | $T_{JCoolMOS}$ | -25 | 150 | °C | |

4.3 Characteristics

4.3.1 Supply Section 1

Note: The electrical characteristics involve the spread of values within the specified supply voltage and junction temperature range T_J from -25 °C to 130 °C . Typical values represent the median values, which are related to 25 °C . If not otherwise stated, a supply voltage of $V_{CC} = 15\text{ V}$ is assumed.

| Parameter | Symbol | Limit Values | | | Unit | Test Condition |
|--|------------------|--------------|------|------|------|--|
| | | min. | typ. | max. | | |
| Start Up Current | $I_{VCCstart}$ | - | 160 | 220 | μA | $V_{VCC} = 14\text{ V}$ |
| VCC Charge Current | $I_{VCCcharge1}$ | 0.55 | 1.05 | 1.60 | mA | $V_{VCC} = 0\text{ V}$ |
| | $I_{VCCcharge2}$ | - | 0.88 | - | mA | $V_{VCC} = 14\text{ V}$ |
| Leakage Current of Start Up Cell and CoolMOS™ | $I_{StartLeak}$ | - | 0.2 | 50 | μA | $V_{VCC} = 16\text{ V}$, $V_{Drain} = 450\text{ V}$ at $T_J = 100\text{ °C}$ |
| Supply Current with Inactive Gate | $I_{VCCsup1}$ | - | 5.5 | 7.0 | mA | |
| Supply Current in Auto Restart Mode with Inactive Gate | $I_{VCCrestart}$ | - | 300 | - | μA | $I_{FB} = 0$ $I_{Softs} = 0$ |
| Supply Current in Active Burst Mode with Inactive Gate | $I_{VCCburst1}$ | - | 1.05 | 1.25 | mA | $V_{VCC} = 15\text{ V}$ $V_{FB} = 3.7\text{ V}$, $V_{SoftS} = 4.4\text{ V}$ |
| | $I_{VCCburst2}$ | - | 0.95 | 1.15 | mA | $V_{VCC} = 9.5\text{ V}$ $V_{FB} = 3.7\text{ V}$, $V_{SoftS} = 4.4\text{ V}$ |
| VCC Turn-On Threshold | V_{VCCon} | 14.2 | 15.0 | 15.8 | V | |
| VCC Turn-Off Threshold | V_{VCCoff} | 8.0 | 8.5 | 9.0 | V | |
| VCC Turn-On/Off Hysteresis | V_{VCChys} | - | 6.5 | - | V | |

Electrical Characteristics
4.3.2 Supply Section 2

| Parameter | Symbol | Limit Values | | | Unit | Test Condition | |
|---------------------------------|---------------------------------|--------------------------|---------------|------|------|----------------|------------------------------------|
| | | min. | typ. | max. | | | |
| Supply Current with Active Gate | ICE3A0365 | $I_{VCCsup2}$ | - | 5.6 | 7.1 | mA | $V_{SoftS} = 4.4V$ $I_{FB} = 0$ |
| | ICE3B0365 | $I_{VCCsup2}$ | - | 5.5 | 7.0 | mA | |
| | ICE3A0565 ICE3A0565Z | $I_{VCCsup2}$ | - | 5.7 | 7.2 | mA | |
| | ICE3B0565 | $I_{VCCsup2}$ | - | 5.6 | 7.1 | mA | |
| | ICE3A1065 | $I_{VCCsup2}$ | - | 5.9 | 7.5 | mA | |
| | ICE3B1065 | $I_{VCCsup2}$ | - | 5.7 | 7.2 | mA | |
| | ICE3A1565 | $I_{VCCsup2}$ | - | 6.3 | 8.0 | mA | |
| | ICE3B1565 | $I_{VCCsup2}$ | - | 6.0 | 7.6 | mA | |
| | ICE3A2065 ICE3A2065Z | $I_{VCCsup2}$ | - | 7.1 | 8.9 | mA | |
| | ICE3B2065 | $I_{VCCsup2}$ | - | 6.5 | 8.2 | mA | |
| | ICE3A2565 | $I_{VCCsup2}$ | - | 8.1 | 10.2 | mA | |
| | ICE3B2565 | $I_{VCCsup2}$ | - | 7.2 | 9.0 | mA | |
| | Supply Current with Active Gate | ICE3A2065I ICE3A2065P | $I_{VCCsup2}$ | - | 5.9 | 7.5 | |
| ICE3B2065I ICE3B2065P | | $I_{VCCsup2}$ | - | 5.7 | 7.2 | mA | |
| ICE3A3065I ICE3A3065P | | $I_{VCCsup2}$ | - | 6.1 | 7.7 | mA | |
| ICE3B3065I ICE3B3065P | | $I_{VCCsup2}$ | - | 5.9 | 7.4 | mA | |
| ICE3A3565I ICE3A3565P | | $I_{VCCsup2}$ | - | 6.4 | 8.0 | mA | |
| ICE3B3565I ICE3B3565P | | $I_{VCCsup2}$ | - | 6.0 | 7.6 | mA | |
| ICE3A5065I ICE3A5065P | | $I_{VCCsup2}$ | - | 7.2 | 9.0 | mA | |
| ICE3B5065I ICE3B5065P | | $I_{VCCsup2}$ | - | 6.6 | 8.3 | mA | |
| ICE3A5565I ICE3A5565P | | $I_{VCCsup2}$ | - | 7.6 | 9.5 | mA | |
| ICE3B5565I ICE3B5565P | | $I_{VCCsup2}$ | - | 6.8 | 8.5 | mA | |

Electrical Characteristics
4.3.3 Internal Voltage Reference

| Parameter | Symbol | Limit Values | | | Unit | Test Condition |
|---------------------------|-----------|--------------|------|------|------|------------------------------------|
| | | min. | typ. | max. | | |
| Trimmed Reference Voltage | V_{REF} | 6.37 | 6.50 | 6.63 | V | measured at pin FB $I_{FB} = 0$ |

4.3.4 PWM Section

| Parameter | | Symbol | Limit Values | | | Unit | Test Condition |
|------------------------------------|---|----------------|--------------|------|------|------------|---|
| | | | min. | typ. | max. | | |
| Fixed Oscillator Frequency | ICE3Axx65 ICE3Axx65Z ICE3Axx65I ICE3Axx65P | f_{OSC1} | 92 | 100 | 108 | kHz | $T_j = 25^\circ\text{C}$ |
| | | f_{OSC2} | 94 | 100 | 106 | | |
| Fixed Oscillator Frequency | ICE3Bxx65 ICE3Bxx65I ICE3Bxx65P | f_{OSC1} | 61 | 67 | 73 | kHz | $T_j = 25^\circ\text{C}$ |
| | | f_{OSC2} | 63 | 67 | 71 | | |
| Max. Duty Cycle | | D_{max} | 0.67 | 0.72 | 0.77 | | |
| Min. Duty Cycle | | D_{min} | 0 | - | - | | $V_{FB} < 0.3\text{V}$ |
| PWM-OP Gain | | A_v | 3.5 | 3.7 | 3.9 | | |
| Voltage Ramp Max Level | | $V_{Max-Ramp}$ | - | 0.85 | - | V | |
| V_{FB} Operating Range Min Level | | V_{FBmin} | 0.3 | 0.7 | - | V | |
| V_{FB} Operating Range Max level | | V_{FBmax} | - | - | 4.75 | V | CS=1V, limited by Comparator C4 ¹⁾ |
| FB Pull-Up Resistor | | R_{FB} | 16 | 20 | 27 | k Ω | |
| SoftS Pull-Up Resistor | | R_{SoftS} | 39 | 50 | 62 | k Ω | |

¹⁾ The parameter is not subjected to production test - verified by design/characterization

Electrical Characteristics
4.3.5 Control Unit

| Parameter | Symbol | Limit Values | | | Unit | Test Condition |
|--|------------------|--------------|------|------|------|-------------------------------------|
| | | min. | typ. | max. | | |
| Deactivation Level for SoftS Comparator C7 by C2 | $V_{SoftSC2}$ | 3.85 | 4.00 | 4.15 | V | $V_{FB} > 5V$ |
| Clamped V_{SoftS} Voltage during Normal Operating Mode | $V_{SoftSclmp}$ | 4.23 | 4.40 | 4.57 | V | $V_{FB} = 4V$ |
| Activation Limit of Comparator C3 | $V_{SoftSC3}$ | 5.20 | 5.40 | 5.60 | V | $V_{FB} > 5V$ |
| SoftS Startup Current | $I_{SoftSstart}$ | - | 1.3 | - | mA | $V_{SoftS} = 0V$ |
| Over Load & Open Loop Detection Limit for Comparator C4 | V_{FBC4} | 4.62 | 4.80 | 4.98 | V | $V_{SoftS} > 5.6V$ |
| Active Burst Mode Level for Comparator C5 | V_{FBC5} | 1.23 | 1.30 | 1.37 | V | $V_{SoftS} > 5.6V$ |
| Active Burst Mode Level for Comparator C6a | V_{FBC6a} | 3.85 | 4.00 | 4.15 | V | After Active Burst Mode is entered |
| Active Burst Mode Level for Comparator C6b | V_{FBC6b} | 3.25 | 3.40 | 3.55 | V | After Active Burst Mode is entered |
| Overvoltage Detection Limit | V_{VCCOVP} | 16.1 | 17.1 | 18.1 | V | $V_{FB} > 5V$ $V_{SoftS} < 4.0V$ |
| Thermal Shutdown ¹⁾ | T_{jSD} | 130 | 140 | 150 | °C | |
| Spike Blanking | t_{Spike} | - | 8.0 | - | μs | |

¹⁾ The parameter is not subjected to production test - verified by design/characterization

Note: The trend of all the voltage levels in the Control Unit is the same regarding the deviation except V_{VCCOVP} and V_{VCCPD}

4.3.6 Current Limiting

| Parameter | Symbol | Limit Values | | | Unit | Test Condition |
|---|--------------|--------------|-------|-------|------|---|
| | | min. | typ. | max. | | |
| Peak Current Limitation (incl. Propagation Delay) | V_{csth} | 0.97 | 1.02 | 1.07 | V | $dV_{sense}/dt = 0.6V/\mu s$ (see Figure 16) |
| Peak Current Limitation during Active Burst Mode | V_{CS2} | 0.232 | 0.257 | 0.282 | V | |
| Leading Edge Blanking | t_{LEB} | - | 220 | - | ns | $V_{SoftS} = 4.4V$ |
| CS Input Bias Current | I_{CSbias} | -1.0 | -0.2 | 0 | μA | $V_{CS} = 0V$ |

Electrical Characteristics
4.3.7 CoolMOS™ Section

| Parameter | | Symbol | Limit Values | | | Unit | Test Condition |
|--|--|---------------|--------------|--------------|--------------|----------------------|---|
| | | | min. | typ. | max. | | |
| Drain Source Breakdown Voltage ICE3Axx65/xx65I/xx65P ICE3Bxx65/xx65I/xx65P | | $V_{(BR)DSS}$ | 600 650 | - - | - - | V V | $T_j = 25^\circ\text{C}$ $T_j = 110^\circ\text{C}$ |
| Drain Source On-Resistance | ICE3A0365 ICE3B0365 | R_{DSon1} | - - | 6.45 13.7 | 7.50 17.0 | Ω Ω | $T_j = 25^\circ\text{C}$ $T_j = 125^\circ\text{C}^{(1)}$ at $I_D = 0.3\text{A}$ |
| | ICE3A0565 ICE3A0565Z ICE3B0565 | R_{DSon2} | - - | 4.70 10.0 | 5.44 12.5 | Ω Ω | $T_j = 25^\circ\text{C}$ $T_j = 125^\circ\text{C}^{(1)}$ at $I_D = 0.5\text{A}$ |
| | ICE3A1065 ICE3B1065 | R_{DSon3} | - - | 2.95 6.6 | 3.42 7.56 | Ω Ω | $T_j = 25^\circ\text{C}$ $T_j = 125^\circ\text{C}^{(1)}$ at $I_D = 1.0\text{A}$ |
| | ICE3A1565 ICE3B1565 | R_{DSon4} | - - | 1.70 3.57 | 1.96 4.12 | Ω Ω | $T_j = 25^\circ\text{C}$ $T_j = 125^\circ\text{C}^{(1)}$ at $I_D = 1.5\text{A}$ |
| | ICE3A2065 ICE3A2065Z ICE3B2065 | R_{DSon5} | - - | 0.92 1.93 | 1.05 2.22 | Ω Ω | $T_j = 25^\circ\text{C}$ $T_j = 125^\circ\text{C}^{(1)}$ at $I_D = 2.0\text{A}$ |
| | ICE3A2565 ICE3B2565 | R_{DSon6} | - - | 0.65 1.37 | 0.75 1.58 | Ω Ω | $T_j = 25^\circ\text{C}$ $T_j = 125^\circ\text{C}^{(1)}$ at $I_D = 2.5\text{A}$ |
| Drain Source On-Resistance | ICE3A2065I ICE3A2065P ICE3B2065I ICE3B2065P | R_{DSon7} | - - | 3.00 6.6 | 3.47 7.63 | Ω Ω | $T_j = 25^\circ\text{C}$ $T_j = 125^\circ\text{C}^{(1)}$ at $I_D = 1.0\text{A}$ |
| | ICE3A3065I ICE3A3065P ICE3B3065I ICE3B3065P | R_{DSon8} | - - | 2.10 4.41 | 2.43 5.10 | Ω Ω | $T_j = 25^\circ\text{C}$ $T_j = 125^\circ\text{C}^{(1)}$ at $I_D = 1.5\text{A}$ |
| | ICE3A3565I ICE3A3565P ICE3B3565I ICE3B3565P | R_{DSon9} | - - | 1.55 3.26 | 1.80 3.78 | Ω Ω | $T_j = 25^\circ\text{C}$ $T_j = 125^\circ\text{C}^{(1)}$ at $I_D = 1.8\text{A}$ |
| | ICE3A5065I ICE3A5065P ICE3B5065I ICE3B5065P | R_{DSon10} | - - | 0.95 2.00 | 1.10 2.31 | Ω Ω | $T_j = 25^\circ\text{C}$ $T_j = 125^\circ\text{C}^{(1)}$ at $I_D = 2.5\text{A}$ |
| | ICE3A5565I ICE3A5565P ICE3B5565I ICE3B5565P | R_{DSon11} | - - | 0.79 1.68 | 0.91 1.92 | Ω Ω | $T_j = 25^\circ\text{C}$ $T_j = 125^\circ\text{C}^{(1)}$ at $I_D = 2.8\text{A}$ |

Electrical Characteristics

| Parameter | Symbol | Limit Values | | | Unit | Test Condition | |
|--|--|---------------|------------------|-------|------|----------------|-----------------------|
| | | min. | typ. | max. | | | |
| Effective output capacitance, energy related | ICE3A0365 ICE3B0365 | $C_{o(er)1}$ | - | 3.65 | - | pF | $V_{DS} = 0V$ to 480V |
| | ICE3A0565 ICE3A0565Z ICE3B0565 | $C_{o(er)2}$ | - | 4.75 | - | pF | |
| | ICE3A1065 ICE3B1065 | $C_{o(er)3}$ | - | 7.0 | - | pF | |
| | ICE3A1565 ICE3B1565 | $C_{o(er)4}$ | - | 11.63 | - | pF | |
| | ICE3A2065 ICE3A2065Z ICE3B2065 | $C_{o(er)5}$ | - | 21 | - | pF | |
| | ICE3A2565 ICE3B2565 | $C_{o(er)6}$ | - | 26.0 | - | pF | |
| Effective output capacitance, energy related | ICE3A2065I ICE3A2065P ICE3B2065I ICE3B2065P | $C_{o(er)7}$ | - | 7.0 | - | pF | $V_{DS} = 0V$ to 480V |
| | ICE3A3065I ICE3A3065P ICE3B3065I ICE3B3065P | $C_{o(er)8}$ | - | 10.0 | - | pF | |
| | ICE3A3565I ICE3A3565P ICE3B3565I ICE3B3565P | $C_{o(er)9}$ | - | 14.0 | - | pF | |
| | ICE3A5065I ICE3A5065P ICE3B5065I ICE3B5065P | $C_{o(er)10}$ | - | 20.5 | - | pF | |
| | ICE3A5565I ICE3A5565P ICE3B5565I ICE3B5565P | $C_{o(er)11}$ | - | 23.0 | - | pF | |
| Rise Time | t_{rise} | - | 30 ²⁾ | - | ns | | |
| Fall Time | t_{fall} | - | 30 ²⁾ | - | ns | | |

1) The parameter is not subjected to production test - verified by design/characterization

2) Measured in a Typical Flyback Converter Application

5 Outline Dimension

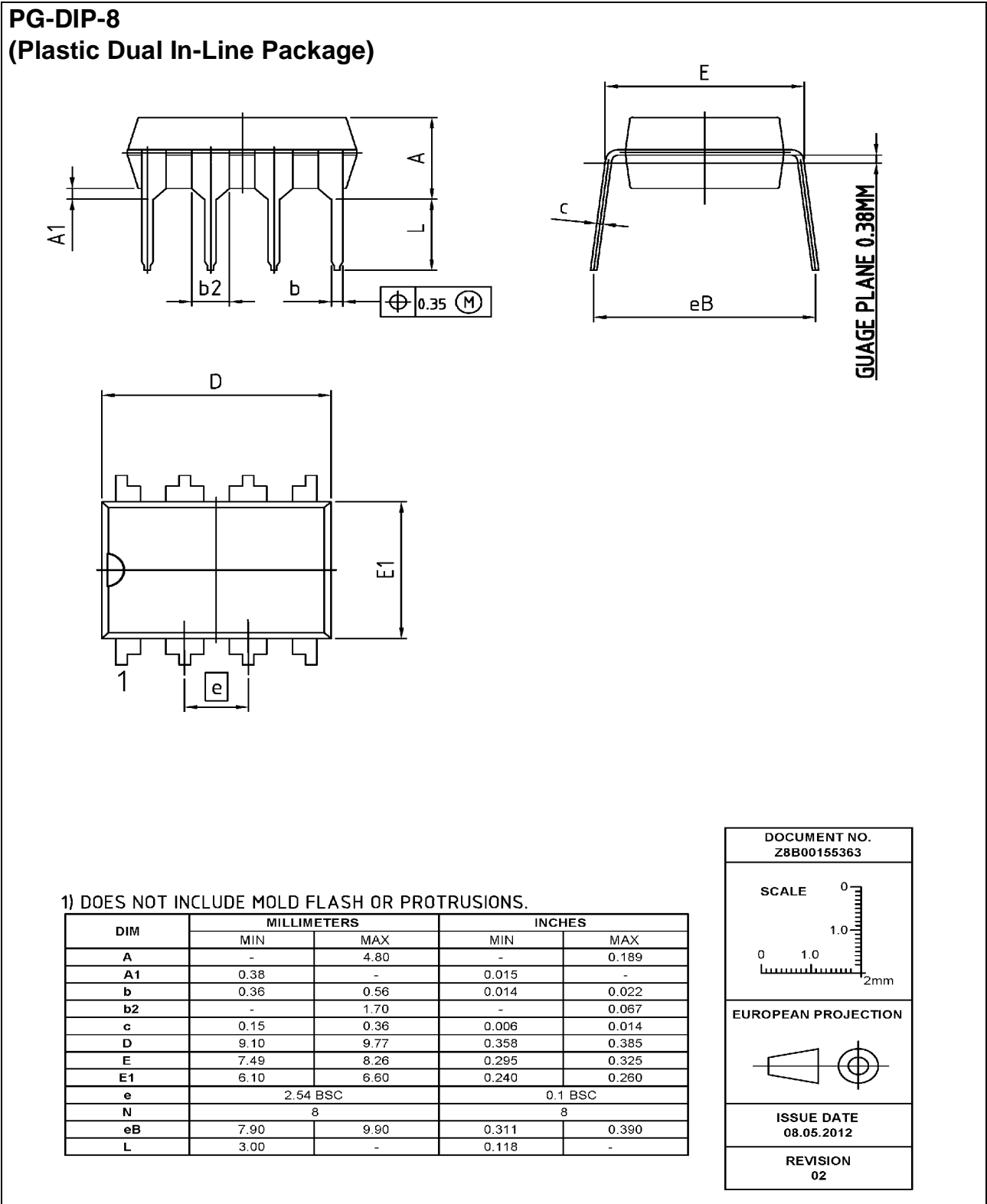
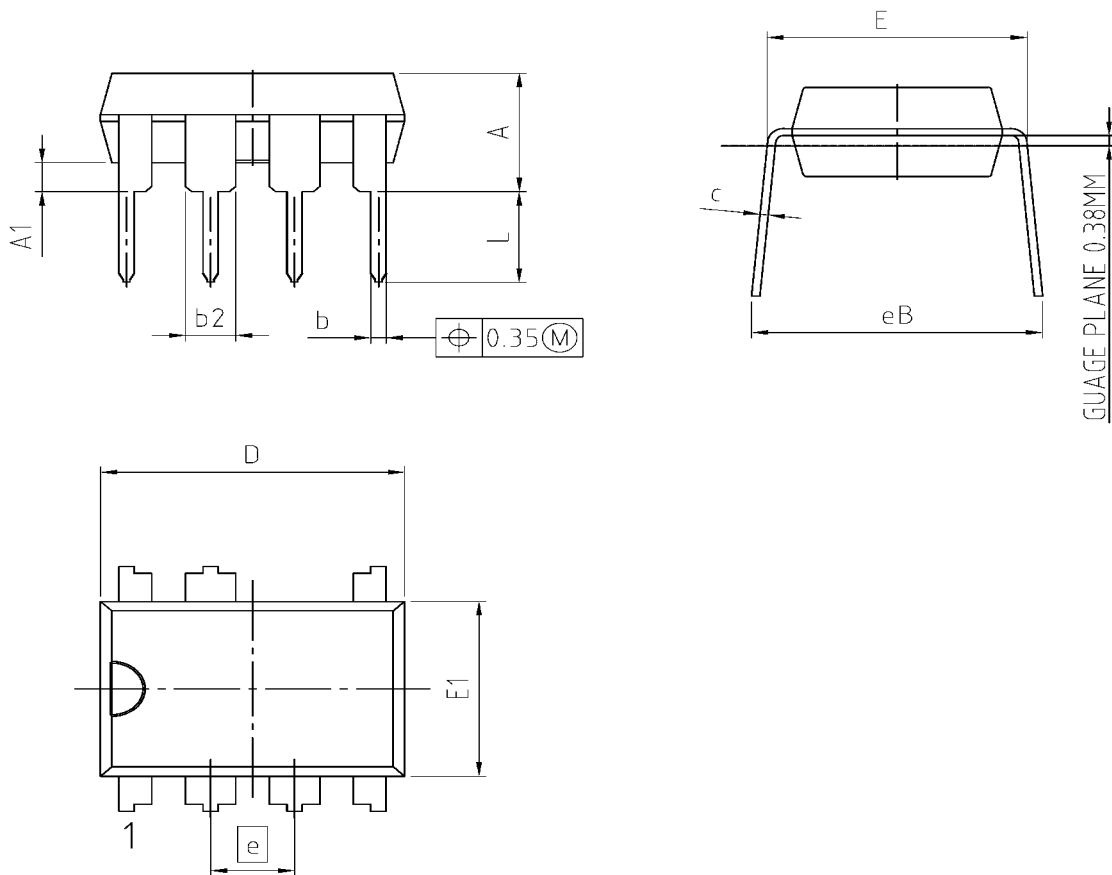

Figure 21 PG-DIP-8 (Pb-free lead plating Plastic Dual In-Line Outline)

Outline Dimension
**PG-DIP-7-1
(Plastic Dual In-Line package)**

1) DOES NOT INCLUDE MOLD FLASH OR PROTRUSIONS.

| DIM | MILLIMETERS | | INCHES | |
|-----|-------------|-------|---------|-------|
| | MIN | MAX | MIN | MAX |
| A | - | 4.57 | - | 0.180 |
| A1 | 0.38 | - | 0.015 | - |
| b | 0.36 | 0.56 | 0.014 | 0.022 |
| b2 | - | 1.70 | - | 0.067 |
| c | 0.20 | 0.36 | 0.008 | 0.014 |
| D | 9.10 | 9.77 | 0.358 | 0.385 |
| E | 7.49 | 8.26 | 0.295 | 0.325 |
| E1 | 6.10 | 6.60 | 0.240 | 0.260 |
| e | 2.54 BSC | | 0.1 BSC | |
| N | 7 | | 7 | |
| eB | 7.90 | 10.90 | 0.311 | 0.429 |
| L | 2.92 | - | 0.115 | - |

DOCUMENT NO.
Z8B00155542

SCALE

EUROPEAN PROJECTION

ISSUE DATE
22.07.2011

REVISION
02

Figure 22 PG-DIP-7-1 (Pb-free lead plating Plastic Dual In-Line Outline)

Outline Dimension

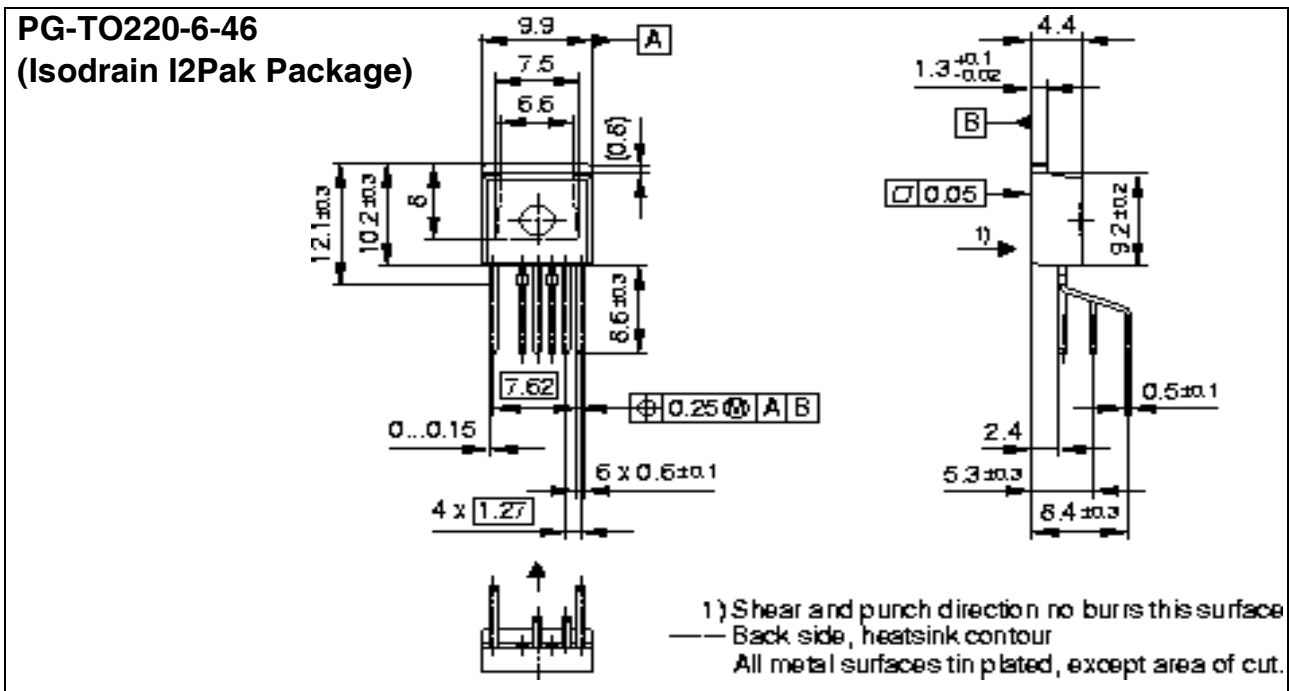

Figure 23 PG-TO220-6-46 (Pb-free lead plating Isodrain I2Pak Package)

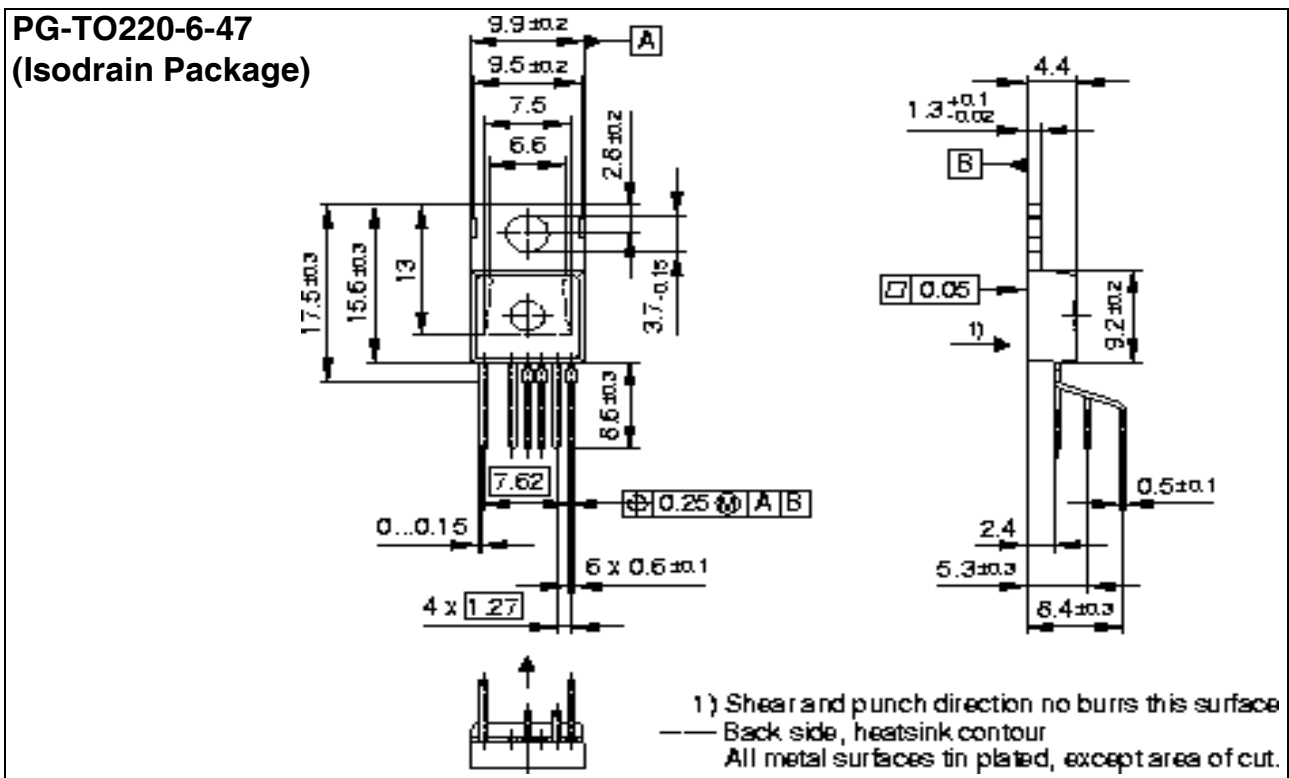

Figure 24 PG-TO220-6-47 (Pb-free lead plating Isodrain Package)

Dimensions in mm

Total Quality Management

Qualität hat für uns eine umfassende Bedeutung. Wir wollen allen Ihren Ansprüchen in der bestmöglichen Weise gerecht werden. Es geht uns also nicht nur um die Produktqualität – unsere Anstrengungen gelten gleichermaßen der Lieferqualität und Logistik, dem Service und Support sowie allen sonstigen Beratungs- und Betreuungsleistungen.

Dazu gehört eine bestimmte Geisteshaltung unserer Mitarbeiter. Total Quality im Denken und Handeln gegenüber Kollegen, Lieferanten und Ihnen, unserem Kunden. Unsere Leitlinie ist jede Aufgabe mit „Null Fehlern“ zu lösen – in offener Sichtweise auch über den eigenen Arbeitsplatz hinaus – und uns ständig zu verbessern.

Unternehmensweit orientieren wir uns dabei auch an „top“ (Time Optimized Processes), um Ihnen durch größere Schnelligkeit den entscheidenden Wettbewerbsvorsprung zu verschaffen.

Geben Sie uns die Chance, hohe Leistung durch umfassende Qualität zu beweisen.

Wir werden Sie überzeugen.

Quality takes on an all-encompassing significance at Semiconductor Group. For us it means living up to each and every one of your demands in the best possible way. So we are not only concerned with product quality. We direct our efforts equally at quality of supply and logistics, service and support, as well as all the other ways in which we advise and attend to you.

Part of this is the very special attitude of our staff. Total Quality in thought and deed, towards co-workers, suppliers and you, our customer. Our guideline is “do everything with zero defects”, in an open manner that is demonstrated beyond your immediate workplace, and to constantly improve.

Throughout the corporation we also think in terms of Time Optimized Processes (top), greater speed on our part to give you that decisive competitive edge.

Give us the chance to prove the best of performance through the best of quality – you will be convinced.

<http://www.infineon.com>

X-ON Electronics

Largest Supplier of Electrical and Electronic Components

Click to view similar products for [AC/DC Converters](#) category:

Click to view products by [Infineon](#) manufacturer:

Other Similar products are found below :

[FSFR2100US](#) [AP3776MTR-G1](#) [BP5037B15](#) [BP5722A12](#) [NCP1070STCT3G](#) [NCP1076STBT3G](#) [NCP1910B100DWR2G](#) [ICE3AR0680VJZ](#)
[ICE3AR1080VJZ](#) [ICE3AR1580VJZ](#) [ICE3AR2280CJZ](#) [ICE3BR2280JZ](#) [ICE3RBR4765JZ](#) [SEA01](#) [FAN7621SSJX](#) [MP172GJ-Z](#) [MP174GJ-P](#)
[BP5011](#) [BP5055-12](#) [BP5710-1](#) [BP5718A12](#) [ICE2QR4780Z](#) [ICE3AR4780VJZ](#) [NCP1077P130G](#) [NCP1077STBT3G](#) [VIPER0PLD](#)
[FSL206MRLX](#) [NCP1060BD100R2G](#) [NCP1124BP100G](#) [AP3983EP7-G1](#) [TEA19363T/1J](#) [AP3171MPTR-G1](#) [ICE3B0365J](#) [NCP1070P100G](#)
[AP3125CMKTR-G1](#) [NCP1076P100G](#) [MP174GS-Z](#) [MP171GJ-Z](#) [MP150GS](#) [SC1076P065G](#) [NCP1071STBT3G](#) [NCP1071P100G](#)
[NCP1070P130G](#) [VI-RUR22-EWXX](#) [AME15-512TCJZ](#) [47132](#) [47165](#) [47220](#) [47223](#) [47224](#)