

# FEATURES SELECTION GUIDE

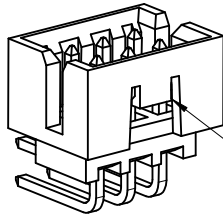

② CENTER LOCK

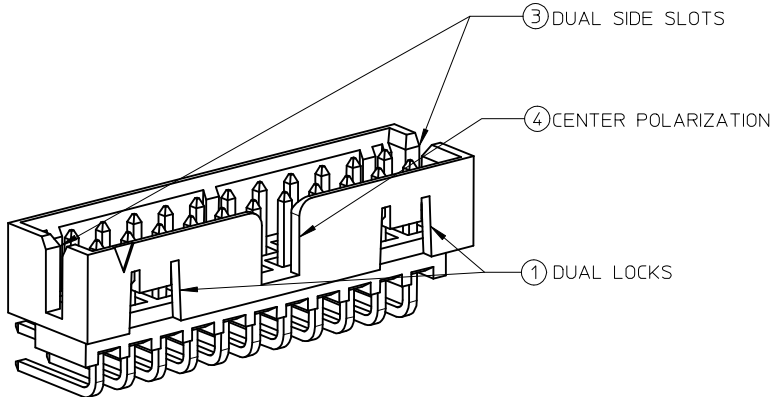

③ DUAL SIDE SLOTS

④ CENTER POLARIZATION

① DUAL LOCKS

CIRCUIT SIZE	FEATURES				SHEET NO
	FRICTION LOCKS		③ DUAL SIDE SLOTS	④ CENTER POLARIZATION	
	① DUAL	② CENTER			
4 - 6	N.A	N.A	YES	N.A	2 - 3
	N.A	YES	YES	N.A	
8 TO 12	N.A	N.A	YES	YES	4 - 5
	N.A	YES	YES	N.A	
14 TO 50	YES	N.A	YES	YES	6 - 9
	N.A	N.A	YES	YES	

SEE SHEET 2,4,6,7 EC NO: S2016-0454 DRWG:GMENARLY 2015/11/05 CHK'D:CGOH 2015/11/17 APPR:KHL JM 2015/11/18	QUALITY SYMBOLS	GENERAL TOLERANCES (UNLESS SPECIFIED)		DIMENSION STYLE	SCALE	DESIGN UNITS	THIRD ANGLE PROJECTION	
	$F_{\Delta} = 0$	mm	INCH	MM ONLY	NTS	METRIC		
	$F_{\square} = 0$	4 PLACES ± --- ± ---	3 PLACES ± --- ± ---	DRAWN BY	DATE	TITLE		
	$F_{\nabla} = 0$	2 PLACES ± 0.20 ± ---	1 PLACE ± --- ± ---	CHECKED BY	DATE	MILLIGRID 2MM PITCH, SMT R/A SHROUDED HEADER <b>molex</b>		
	$F_{\circ} = 0$	0 PLACE ± --- ± ---	0 PLACE ± --- ± ---	APPROVED BY	DATE			
	ANGULAR ± 3 °	DRAFT WHERE APPLICABLE MUST REMAIN WITHIN DIMENSIONS		SEE TABLE	SD-87833-0001		1 OF 9	
A1	REV			SIZE	THIS DRAWING CONTAINS INFORMATION THAT IS PROPRIETARY TO MOLEX INCORPORATED AND SHOULD NOT BE USED WITHOUT WRITTEN PERMISSION			

4 TO 6 CIRCUITS

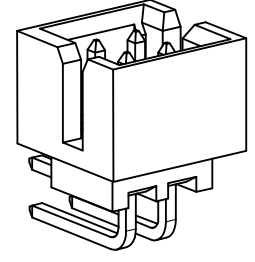
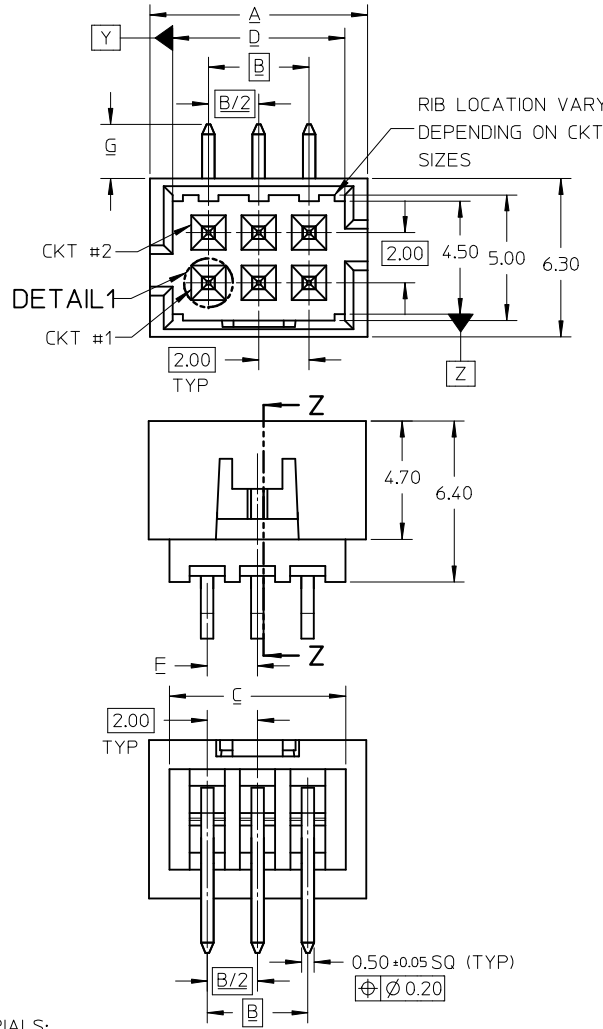

ISO VIEW OF HEADER DUAL SIDE SLOTS

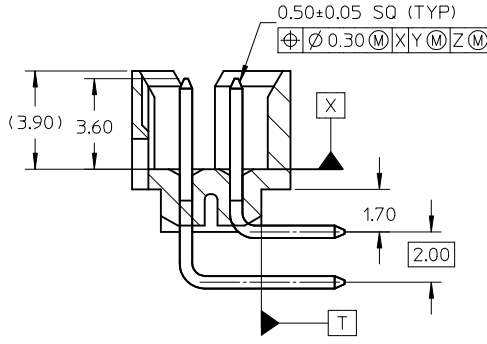

SECTION Z-Z

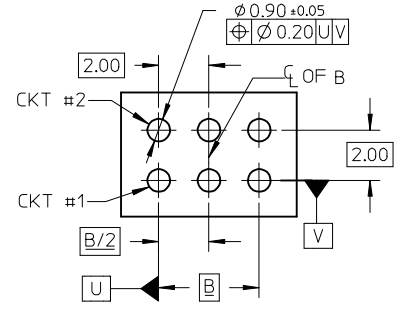
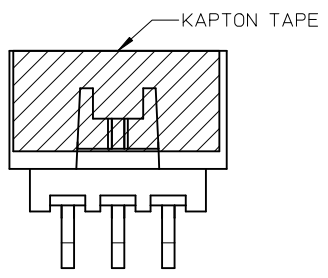

RECOMMENDED PCB LAYOUT

- NOTES:
- MATERIALS:  
HOUSING: 30% GF, NYLON, UL94V-0. COLOR: BLACK  
PIN: 0.50MM SQ PHOSPHOR BRONZE
  - FINISHES: REFER TO PLATING OPTIONS
  - PRODUCT SPECIFICATION: PS-87831-027
  - PACKAGING SPECIFICATION:  
TUBE: PK-87831-001, TAPE AND REEL: PK-87831-300
  - MATES WITH: A. MOLEX CRIMP RECEPTACLE HOUSING: 51110 SERIES AND CRIMP TERMINAL: 50394 SERIES  
B. MOLEX 2MM MILLIGRID DUAL ROW IDT: 87568 SERIES  
C. MOLEX 2MM MILLIGRID DUAL ROW RECEPTACLE: 79107 (GOLD PLATED), 78787 (TIN PLATED)
  - FOR ILLUSTRATION PURPOSE, 6 CIRCUITS HEADER IS SHOWN

<b>ADD NOTE 6</b> IEC NO: S2016-0454 DRWNG: GMENARLY 2015/11/05 CHK'D: CGOH 2015/11/17 APPR: KHL IM 2015/11/18	QUALITY SYMBOLS $\nabla_F = 0$ $\nabla_E = 0$ $\nabla_D = 0$	GENERAL TOLERANCES (UNLESS SPECIFIED)		DIMENSION STYLE <b>MM ONLY</b>		SCALE NTS	DESIGN UNITS METRIC	THIRD ANGLE PROJECTION	
		4 PLACES ± --- ± --- 3 PLACES ± --- ± --- 2 PLACES ± 0.20 ± --- 1 PLACE ± --- ± --- 0 PLACE ± --- ± ---	mm INCH	DRAWN BY GMENARLY	DATE 2015/09/29	TITLE MILLIGRID 2MM PITCH, SMT R/A SHROUDED HEADER			
		ANGULAR ± 3°		CHECKED BY CGOH	DATE 2015/10/30	DOCUMENT NO. SD-87833-0001			
		DRAFT WHERE APPLICABLE MUST REMAIN WITHIN DIMENSIONS		APPROVED BY KHL IM	DATE 2015/11/03	SHEET NO. 2 OF 9			
A1	REV	SIZE A3		THIS DRAWING CONTAINS INFORMATION THAT IS PROPRIETARY TO MOLEX INCORPORATED AND SHOULD NOT BE USED WITHOUT WRITTEN PERMISSION					

4 TO 6 CIRCUITS

CKT SIZE	ASSY P/N WITHOUT KAPTON IN TUBE	ASSY P/N WITH KAPTON IN TUBE	ASSY P/N WITH KAPTON IN T&R	PLATING OPTIONS	FRICTION LOCKS		DUAL SIDE SLOTS	CENTER POLARIZATION	DIMENSION							
					DUAL	CENTER			A	B	C	D	E	F	G (SOLDER TAIL)	
4	87833-0419	N.A	N.A	1	N.A	N.A	YES	N.A	6.65	2.00	5.00	4.85	N.A	N.A	2.16	
	87833-0420	N.A	N.A	2												
	87833-0421	N.A	N.A	3	N.A	N.A	YES	N.A						N.A	1.00	2.16
	87833-5920	N.A	N.A	2												
	87833-0431	87833-0441	87833-0451	2	N.A	YES	YES	N.A						1.00	3.18	
	87833-0432	N.A	N.A	3												
87833-0461	N.A	N.A	2	N.A	YES	YES	N.A	1.00	3.18							
6	87833-0619	N.A	N.A	1	N.A	N.A	YES	N.A	8.65	4.00	7.00	6.85	N.A	N.A	2.16	
	87833-0620	N.A	N.A	2												
	87833-0621	N.A	N.A	3	N.A	N.A	YES	N.A						N.A	3.18	
	87833-6420	N.A	N.A	2												
	87833-0631	87833-0641	87833-0651	2	N.A	YES	YES	N.A						2.00	2.16	
	87833-0632	N.A	N.A	3												
	87833-0661	N.A	N.A	2	N.A	YES	YES	N.A						2.00	3.18	
	87833-0624	N.A	N.A	2												
87833-0625	N.A	N.A	3	N.A	N.A	YES	N.A	N.A	2.92							

PLATING OPTIONS:

- 1 - 0.05-0.13um/2-5uin GOLD IN CONTACT AREA AND 1.88um/75uin MIN. MATTE TIN IN SOLDER TAIL AREA OVER 1.27um/50uin MIN. NICKEL OVERALL.
- 2 - 0.38um/15uin MIN. GOLD IN CONTACT AREA AND 1.88um/75uin MIN. MATTE TIN IN SOLDER TAIL AREA OVER 1.27um/50uin MIN. NICKEL OVERALL.
- 3 - 0.76um/30uin MIN. GOLD IN CONTACT AREA AND 1.88um/75uin MIN. MATTE TIN IN SOLDER TAIL AREA OVER 1.27um/50uin MIN. NICKEL OVERALL.

SEE SHEET 2,4,6,7 EC NO: S2016-0454 DRWN:GMENARLY 2015/11/05 CHKD:CGOH 2015/11/17 APPR:KHL IM 2015/11/18	QUALITY SYMBOLS	GENERAL TOLERANCES (UNLESS SPECIFIED)	DIMENSION STYLE	SCALE	DESIGN UNITS	THIRD ANGLE PROJECTION
	$\nabla_A = 0$ $\nabla_C = 0$ $\nabla_P = 0$	mm    INCH 4 PLACES ± --- ± --- 3 PLACES ± --- ± --- 2 PLACES ± 0.20 ± --- 1 PLACE ± --- ± --- 0 PLACE ± --- ± ---	MM ONLY	NTS	METRIC	
	DRAWN BY: GMENARLY    DATE: 2015/09/29 CHECKED BY: CGOH    DATE: 2015/10/30 APPROVED BY: KHL IM    DATE: 2015/11/03	MATERIAL NO.    DOCUMENT NO.    SHEET NO. SEE TABLE    SD-87833-0001    3 OF 9	MILLIGRID 2MM PITCH, SMT R/A SHROUDED HEADER 			
	DRAFT WHERE APPLICABLE MUST REMAIN WITHIN DIMENSIONS	ANGULAR ± 3 ° THIS DRAWING CONTAINS INFORMATION THAT IS PROPRIETARY TO MOLEX INCORPORATED AND SHOULD NOT BE USED WITHOUT WRITTEN PERMISSION	SIZE: A3			

8 TO 12 CIRCUITS

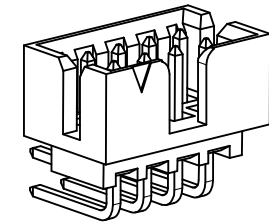
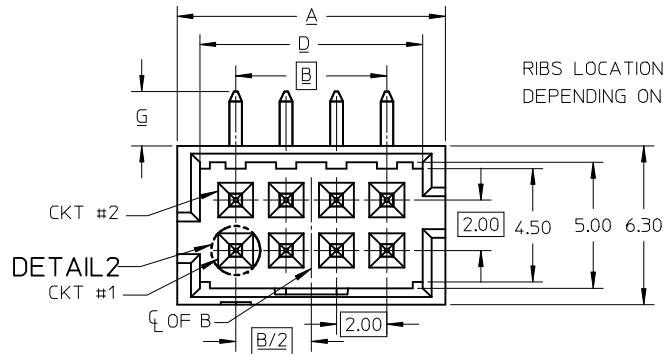

ISO VIEW OF HEADER WITH CENTER POLARIZATION AND DUAL SIDE SLOTS

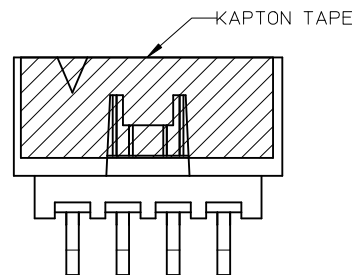
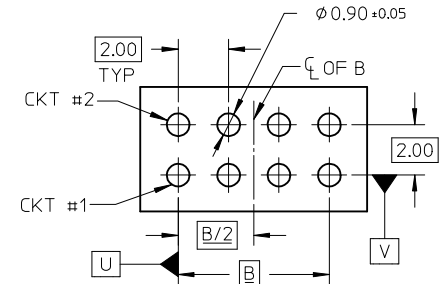
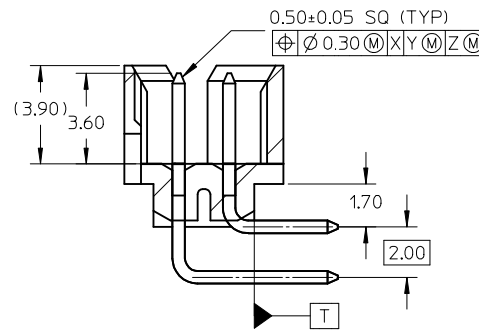
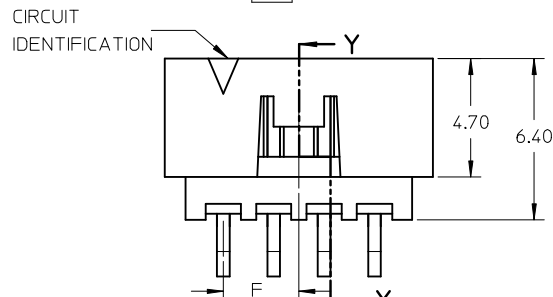

NOTES:

1. MATERIALS:  
HOUSING: 30% GF, NYLON, UL94V-0, COLOR: BLACK  
PIN: 0.50MM SQ PHOSPHOR BRONZE
2. FINISHES: REFER TO PLATING OPTIONS
3. PRODUCT SPECIFICATION: PS-87831-027
4. PACKAGING SPECIFICATION:  
TUBE: PK-87831-001, TAPE AND REEL: PK-87831-300
5. MATES WITH: A. MOLEX CRIMP RECEPTACLE HOUSING: 51110 SERIES AND CRIMP TERMINAL: 50394 SERIES  
B. MOLEX 2MM MILLIGRID DUAL ROW IDT: 87568 SERIES  
C. MOLEX 2MM MILLIGRID DUAL ROW RECEPTACLE: 79107 (GOLD PLATED), 78787 (TIN PLATED)
6. FOR ILLUSTRATION PURPOSE, 8 CIRCUIT HEADER IS SHOWN

<b>ADD NOTE 6</b> EC NO: S2016-0454 DRWN:GMENARLY 2015/11/05 CHKD:CGOH 2015/11/17 APPR:KHLIM 2015/11/18	QUALITY SYMBOLS $\nabla_A = 0$ $\nabla_E = 0$ $\nabla_F = 0$	GENERAL TOLERANCES (UNLESS SPECIFIED)		DIMENSION STYLE <b>MM ONLY</b>		SCALE NTS	DESIGN UNITS METRIC	THIRD ANGLE PROJECTION		
		mm	INCH	DRAWN BY	DATE	TITLE				
		4 PLACES $\pm$ ---	$\pm$ ---	GMENARLY	2015/09/29	MILLIGRID 2MM PITCH, SMT R/A SHROUDED HEADER <b>molex</b>				
		3 PLACES $\pm$ ---	$\pm$ ---	CHECKED BY	DATE					
2 PLACES $\pm 0.20$	$\pm$ ---	CGOH	2015/10/30	DOCUMENT NO. SD-87833-0001 SHEET NO. 4 OF 9						
1 PLACE $\pm$ ---	$\pm$ ---	APPROVED BY	DATE							
0 PLACE $\pm$ ---	$\pm$ ---	KHLIM	2015/11/03	THIS DRAWING CONTAINS INFORMATION THAT IS PROPRIETARY TO MOLEX INCORPORATED AND SHOULD NOT BE USED WITHOUT WRITTEN PERMISSION						
ANGULAR $\pm 3^\circ$		MATERIAL NO.							SEE TABLE	
DRAFT WHERE APPLICABLE MUST REMAIN WITHIN DIMENSIONS		SIZE		A3						

8 TO 12 CIRCUITS

CKT SIZE	ASSY P/N WITHOUT KAPTON IN TUBE	ASSY P/N WITH KAPTON IN TUBE	ASSY P/N WITH KAPTON IN T&R	PLATING OPTIONS	FRICTION LOCKS		DUAL SIDE SLOTS	CENTER POLARIZATION	DIMENSION							
					DUAL	CENTER			A	B	C	D	E	F	G (SOLDER TAIL)	
8	87833-0819	N.A	N.A	1	N.A	N.A	YES	YES	10.65	6.00	9.00	8.85	N.A	N.A	2.16	
	87833-0820	N.A	N.A	2												
	87833-0821	N.A	N.A	3	N.A	N.A	YES	YES						N.A	3.00	2.16
	87833-6320	N.A	N.A	2												
	87833-6321	N.A	N.A	3	N.A	YES	YES	N.A						3.00	3.18	
	87833-0831	87833-0841	87833-0851	2												
	87833-0832	N.A	N.A	3	N.A	YES	YES	N.A						N.A	2.92	
	87833-0861	N.A	N.A	2												
87833-0824	N.A	N.A	2	N.A	N.A	YES	YES	N.A	2.92							
87833-0825	N.A	N.A	3													
10	87832-1019	N.A	N.A	1	N.A	N.A	YES	YES	12.65	8.00	11.00	10.85	N.A	N.A	2.16	
	87833-1020	N.A	N.A	2												
	87833-1021	N.A	N.A	3	N.A	YES	YES	N.A						4.00	2.16	
	87833-1031	N.A	N.A	2												
	87833-1032	N.A	N.A	3	N.A	YES	YES	N.A						4.00	1.70	
	N.A	87833-1041	87833-1051	2												
87833-1024	N.A	N.A	2	N.A	N.A	YES	YES	N.A	2.92							
87833-1025	N.A	N.A	3													
12	87833-1219	N.A	N.A	1	N.A	N.A	YES	YES	14.65	10.00	13.00	12.85	N.A	N.A	2.16	
	87833-1220	N.A	N.A	2												
	87833-1221	N.A	N.A	3	N.A	N.A	YES	YES						N.A	3.18	
	87833-6020	N.A	N.A	2												
	87833-1231	N.A	N.A	2	N.A	YES	YES	N.A						5.00	2.16	
	87833-1232	N.A	N.A	3												
	87833-1224	N.A	N.A	2	N.A	N.A	YES	YES						N.A	2.92	
87833-1225	N.A	N.A	3													

PLATING OPTIONS:

- 1 - 0.05-0.13um/2-5uin GOLD IN CONTACT AREA AND 1.88um/75uin MIN. MATTE TIN IN SOLDER TAIL AREA OVER 1.27um/50uin MIN. NICKEL OVERALL.
- 2 - 0.38um/15uin MIN. GOLD IN CONTACT AREA AND 1.88um/75uin MIN. MATTE TIN IN SOLDER TAIL AREA OVER 1.27um/50uin MIN. NICKEL OVERALL.
- 3 - 0.76um/30uin MIN. GOLD IN CONTACT AREA AND 1.88um/75uin MIN. MATTE TIN IN SOLDER TAIL AREA OVER 1.27um/50uin MIN. NICKEL OVERALL.

SEE SHEET 2,4,6,7 EC NO: S2016-0454 DRWNG: GEMEARLY 2015/11/05 CHK'D: CGOH 2015/11/17 APPR: KHL IM 2015/11/18	REV A1	DESCRIPTION	QUALITY SYMBOLS	GENERAL TOLERANCES (UNLESS SPECIFIED)	DIMENSION STYLE	SCALE	DESIGN UNITS	THIRD ANGLE PROJECTION			
			$\nabla_A = 0$ $\nabla_C = 0$ $\nabla_P = 0$	mm    INCH 4 PLACES ± --- ± --- 3 PLACES ± --- ± --- 2 PLACES ± 0.20 ± --- 1 PLACE ± --- ± --- 0 PLACE ± --- ± ---	MM ONLY	NTS	METRIC	DRAWN BY: GMENARLY    DATE: 2015/09/29 CHECKED BY: CGOH    DATE: 2015/10/30 APPROVED BY: KHL IM    DATE: 2015/11/03	MILLIGRID 2MM PITCH, SMT R/A SHROUDED HEADER <b>molex</b>		
			ANGULAR ± 3 °	DRAFT WHERE APPLICABLE MUST REMAIN WITHIN DIMENSIONS	SEE TABLE	DOCUMENT NO. SD-87833-0001	SHEET NO. 5 OF 9	THIS DRAWING CONTAINS INFORMATION THAT IS PROPRIETARY TO MOLEX INCORPORATED AND SHOULD NOT BE USED WITHOUT WRITTEN PERMISSION			

14 TO 50 CIRCUITS

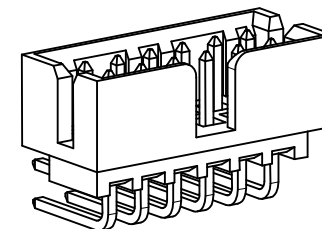
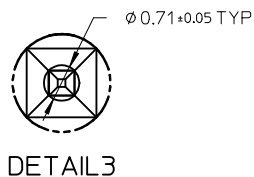
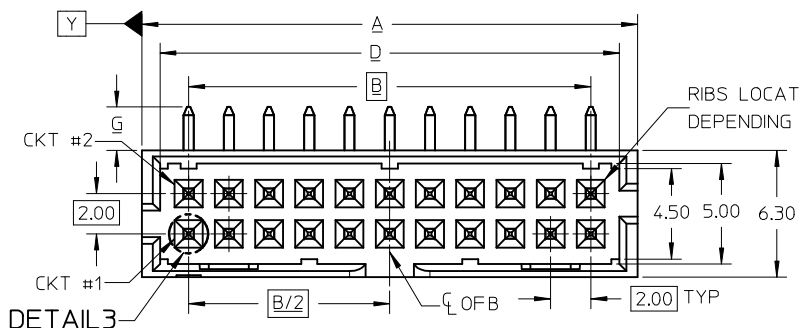

ISO VIEW OF HEADER WITH CENTER POLARIZATION AND DUAL SIDE SLOTS

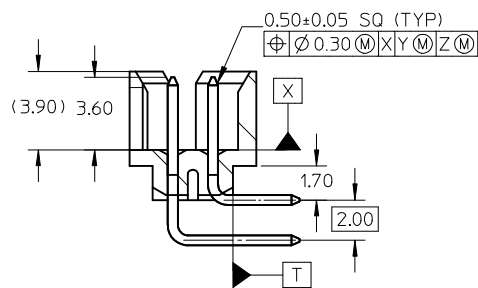
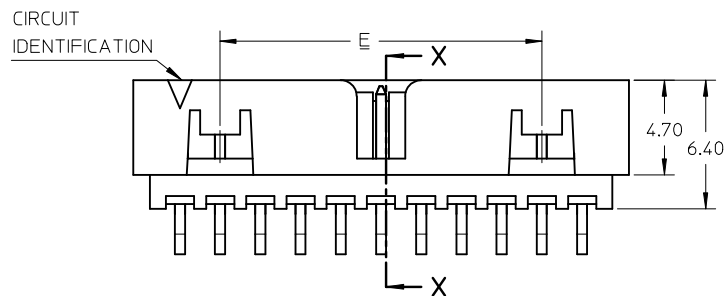

SECTION X-X

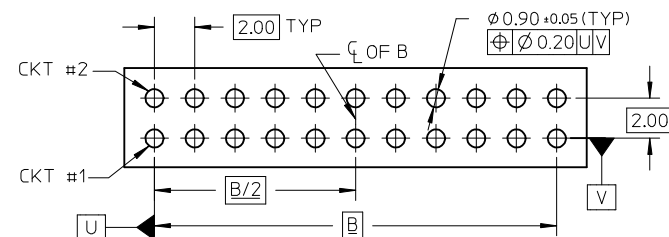
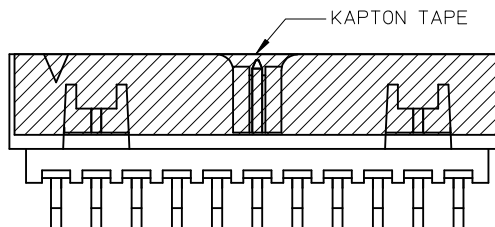
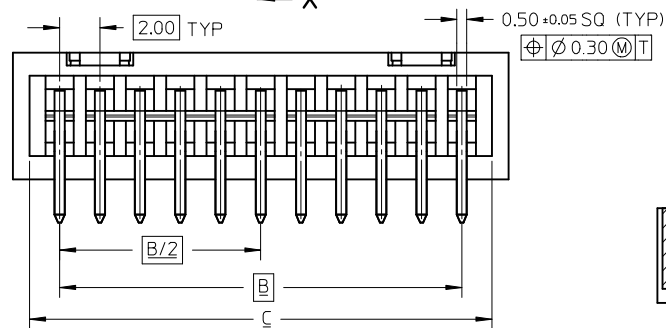

NOTES:

1. MATERIALS:  
HOUSING: 30% GF, NYLON, UL94V-0, COLOR: BLACK  
PIN: 0.50MM SQ PHOSPHOR BRONZE
2. FINISHES: REFER TO PLATING OPTIONS
3. PRODUCT SPECIFICATION: PS-87831-027
4. PACKAGING SPECIFICATION:  
TUBE: PK-87831-001, TAPE AND REEL: PK-87831-300
5. MATES WITH: A. MOLEX CRIMP RECEPTACLE HOUSING: 51110 SERIES AND CRIMP TERMINAL: 50394 SERIES  
B. MOLEX 2MM MILLIGRID DUAL ROW IDT: 87568 SERIES  
C. MOLEX 2MM MILLIGRID DUAL ROW RECEPTACLE: 79107 (GOLD PLATED), 78787 (TIN PLATED)
6. FOR ILLUSTRATION PURPOSE, 22 CIRCUITS HEADER IS SHOWN

ADD NOTE 6 EC NO: S2016-0454 DRWN:GMENARLY 2015/11/05 CHKD:CGOH 2015/11/17 APPR:KHL IM 2015/11/18	DESCRIPTION QUALITY SYMBOLS $F_A=0$ $F_C=0$ $F_P=0$	GENERAL TOLERANCES (UNLESS SPECIFIED)		DIMENSION STYLE		SCALE	DESIGN UNITS	THIRD ANGLE PROJECTION			
				MM ONLY		NTS	METRIC				
				mm	INCH	DRAWN BY	DATE	TITLE			
						GMENARLY	2015/09/29	MILLIGRID 2MM PITCH, SMT R/A SHROUDED HEADER <b>molex</b>			
				CHECKED BY	DATE	DOCUMENT NO.					
				CGOH	2015/10/30	SD-87833-0001		6 OF 9			
				APPROVED BY	DATE	THIS DRAWING CONTAINS INFORMATION THAT IS PROPRIETARY TO MOLEX INCORPORATED AND SHOULD NOT BE USED WITHOUT WRITTEN PERMISSION					
				KHL IM	2015/11/03						
				MATERIAL NO.							
				SEE TABLE							
				ANGULAR ± 3°							
				DRAFT WHERE APPLICABLE MUST REMAIN WITHIN DIMENSIONS							
				SIZE							
				A3							

14 TO 24 CIRCUITS

CKT SIZE	ASSY P/N WITHOUT KAPTON IN TUBE	ASSY P/N WITH KAPTON IN TUBE	ASSY P/N WITH KAPTON IN T&R	PLATING OPTIONS	FRICTION LOCKS		DUAL SIDE SLOTS	CENTER POLARIZATION	DIMENSION						
					DUAL	CENTER			A	B	C	D	E	F	G (SOLDER TAIL)
14	87833-1419	N.A	N.A	1					16.65	12.00	15.00	14.85	8.00	N.A	2.16
	87833-1420	N.A	N.A	2	YES	N.A	YES	YES							
	87833-1421	N.A	N.A	3											
	87833-5320	N.A	N.A	2	YES	N.A	YES	YES							
	87833-5321	N.A	N.A	3											
	87833-1436	N.A	N.A	3	YES	N.A	YES	YES							3.50
16	87833-1619	N.A	N.A	1					18.65	14.00	17.00	16.85	10.00	N.A	2.16
	87833-1620	N.A	N.A	2	YES	N.A	YES	YES							
	87833-1621	N.A	N.A	3											
	87833-6120	N.A	87833-7120	2	YES	N.A	YES	YES							
18	87833-1819	N.A	N.A	1					20.65	16.00	19.00	18.85	12.00	N.A	2.16
	87833-1820	N.A	N.A	2	YES	N.A	YES	YES							
	87833-1821	N.A	N.A	3											
	87833-6220	N.A	N.A	2	YES	N.A	YES	YES							
20	87833-2019	N.A	N.A	1					22.65	18.00	21.00	20.85	14.00	N.A	2.16
	87833-2020	N.A	87833-7220	2	YES	N.A	YES	YES							
	87833-2021	N.A	N.A	3											
	87833-6520	N.A	N.A	2	YES	N.A	YES	YES							
	87833-6521	N.A	N.A	3											
	87833-2036	N.A	N.A	3	YES	N.A	YES	YES							
22	87833-2219	N.A	N.A	1					24.65	20.00	23.00	22.85	16.00	N.A	2.16
	87833-2220	N.A	N.A	2	YES	N.A	YES	YES							
	87833-2221	N.A	N.A	3											
24	87833-2419	N.A	N.A	1					26.65	22.00	25.00	24.85	18.00	N.A	2.16
	87833-2420	N.A	(A1) 87833-7020	2	YES	N.A	YES	YES							
	87833-2421	N.A	N.A	3											
	87833-2436	N.A	N.A	3	YES	N.A	YES	YES							
	87833-6920	N.A	N.A	2	YES	N.A	YES	YES							

PLATING OPTIONS:

- 1 - 0.05-0.13um/2-5uin GOLD IN CONTACT AREA AND 1.88um/75uin MIN. MATTE TIN IN SOLDER TAIL AREA OVER 1.27um/50uin MIN. NICKEL OVERALL.
- 2 - 0.38um/15uin MIN. GOLD IN CONTACT AREA AND 1.88um/75uin MIN. MATTE TIN IN SOLDER TAIL AREA OVER 1.27um/50uin MIN. NICKEL OVERALL.
- 3 - 0.76um/30uin MIN. GOLD IN CONTACT AREA AND 1.88um/75uin MIN. MATTE TIN IN SOLDER TAIL AREA OVER 1.27um/50uin MIN. NICKEL OVERALL.

ADD P/N 87833-7020 EC NO: S2016-0454 DRWN:GMENARLY 2015/11/05 CHKD:CGOH 2015/11/17 APPR:KHL IM 2015/11/18	QUALITY SYMBOLS F <sub>A</sub> =0 F <sub>G</sub> =0 F <sub>P</sub> =0	GENERAL TOLERANCES (UNLESS SPECIFIED)		DIMENSION STYLE MM ONLY		SCALE NTS	DESIGN UNITS METRIC	THIRD ANGLE PROJECTION		
		mm	INCH	DRAWN BY GMENARLY	DATE 2015/09/29	TITLE MILLIGRID 2MM PITCH, SMT R/A SHROUDED HEADER				
		4 PLACES ± --- ± ---	3 PLACES ± --- ± ---	CHECKED BY CGOH	DATE 2015/10/30	APPROVED BY KHL IM				
		2 PLACES ± 0.20 ± ---	1 PLACE ± --- ± ---	DATE 2015/11/03	MATERIAL NO. DOCUMENT NO. SHEET NO.					
DRAFT WHERE APPLICABLE MUST REMAIN WITHIN DIMENSIONS		ANGULAR ± 3 °		SEE TABLE		SD-87833-0001		7 OF 9		
THIS DRAWING CONTAINS INFORMATION THAT IS PROPRIETARY TO MOLEX INCORPORATED AND SHOULD NOT BE USED WITHOUT WRITTEN PERMISSION										

26 TO 38 CIRCUITS

F	CKT SIZE	ASSY P/N WITHOUT KAPTON IN TUBE	ASSY P/N WITH KAPTON IN TUBE	ASSY P/N WITH KAPTON IN T&R	PLATING OPTIONS	FRICTION LOCKS		DUAL SIDE SLOTS	CENTER POLARIZATION	DIMENSION							
						DUAL	CENTER			A	B	C	D	E	F	G (SOLDER TAIL)	
F	26	87833-2619	N.A	N.A	1												
		87833-2620	N.A	N.A	2												
		87833-2621	N.A	N.A	3	YES	N.A	YES	YES	28.65	24.00	27.00	26.85	20.00	N.A	2.16	
		87833-2636	N.A	N.A	3	YES	N.A	YES	YES							3.50	
E	28	87833-2819	N.A	N.A	1												
		87833-2820	N.A	N.A	2												
		87833-2821	N.A	N.A	3	YES	N.A	YES	YES	30.65	26.00	29.00	28.85	22.00	N.A	2.16	
		87833-6620	N.A	N.A	2	YES	N.A	YES	YES							3.18	
D	30	87832-3019	N.A	N.A	1												
		87833-3020	N.A	N.A	2												
		87833-3021	N.A	N.A	3	YES	N.A	YES	YES	32.65	28.00	31.00	30.85	24.00	N.A	2.16	
		87833-6720	N.A	N.A	2												
		87833-6721	N.A	N.A	3	YES	N.A	YES	YES							3.18	
		87833-3036	N.A	N.A	3	YES	N.A	YES	YES							3.50	
D	32	87833-3219	N.A	N.A	1												
		87833-3220	N.A	N.A	2	YES	N.A	YES	YES	34.65	30.00	33.00	32.85	26.00	N.A	2.16	
		87833-3221	N.A	N.A	3												
C	34	87833-3419	N.A	N.A	1												
		87833-3420	N.A	N.A	2	YES	N.A	YES	YES	36.65	32.00	35.00	34.85	28.00	N.A	2.16	
		87833-3421	N.A	N.A	3												
		87833-5420	N.A	N.A	2	YES	N.A	YES	YES							3.18	
		87833-3424	N.A	N.A	2	N.A	N.A	YES	YES							2.92	
C	36	87833-3619	N.A	N.A	1												
		87833-3620	N.A	N.A	2	YES	N.A	YES	YES	38.65	34.00	37.00	36.85	30.00	N.A	2.16	
		87833-3621	N.A	N.A	3												
A	38	87833-3819	N.A	N.A	1												
		87833-3820	N.A	N.A	2	YES	N.A	YES	YES	40.65	36.00	39.00	38.85	32.00	N.A	2.16	
		87833-3821	N.A	N.A	3												

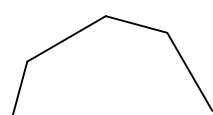

PLATING OPTIONS:

- 1 - 0.05-0.13um/2-5uin GOLD IN CONTACT AREA AND 1.88um/75uin MIN. MATTE TIN IN SOLDER TAIL AREA OVER 1.27um/50uin MIN. NICKEL OVERALL.
- 2 - 0.38um/15uin MIN. GOLD IN CONTACT AREA AND 1.88um/75uin MIN. MATTE TIN IN SOLDER TAIL AREA OVER 1.27um/50uin MIN. NICKEL OVERALL.
- 3 - 0.76um/30uin MIN. GOLD IN CONTACT AREA AND 1.88um/75uin MIN. MATTE TIN IN SOLDER TAIL AREA OVER 1.27um/50uin MIN. NICKEL OVERALL.

SEE SHEET 24.6.7 IEC NO: S2016-0454 DRWN:GMENARLY 2015/11/05 CH'KD:CGOH 2015/11/17 APPR:KHL IM 2015/11/18	QUALITY SYMBOLS	GENERAL TOLERANCES (UNLESS SPECIFIED)		DIMENSION STYLE	SCALE	DESIGN UNITS	THIRD ANGLE PROJECTION
	$F_A=0$ $F_C=0$ $F_B=0$	mm	INCH	MM ONLY	NTS	METRIC	
		4 PLACES ± --- ± ---		DRAWN BY	DATE	TITLE	
		3 PLACES ± --- ± ---		GMENARLY	2015/09/29	MILLIGRID 2MM PITCH, SMT R/A SHROUDED HEADER	
	2 PLACES ± 0.20 ± ---		CHECKED BY	DATE			
	1 PLACE ± --- ± ---		CGOH	2015/10/30			
	0 PLACE ± --- ± ---		APPROVED BY	DATE			
			KHL IM	2015/11/03			
			MATERIAL NO.	DOCUMENT NO.			
				SEE TABLE	SD-87833-0001		
			ANGULAR ± 3 °				
			DRAFT WHERE APPLICABLE MUST REMAIN WITHIN DIMENSIONS				
			SIZE	THIS DRAWING CONTAINS INFORMATION THAT IS PROPRIETARY TO MOLEX INCORPORATED AND SHOULD NOT BE USED WITHOUT WRITTEN PERMISSION			
			A3				
					SHEET NO. 8 OF 9		

40 TO 50 CIRCUITS

CKT SIZE	ASSY P/N WITHOUT KAPTON IN TUBE	ASSY P/N WITH KAPTON IN TUBE	ASSY P/N WITH KAPTON IN T&R	PLATING OPTIONS	FRICTION LOCKS		DUAL SIDE SLOTS	CENTER POLARIZATION	DIMENSION							
					DUAL	CENTER			A	B	C	D	E	F	G (SOLDER TAIL)	
40	87833-4019	N.A	N.A	1												
	87833-4020	N.A	N.A	2	YES	N.A	YES	YES	42.65	38.00	41.00	40.85	34.00	N.A	2.16	
	87833-4021	N.A	N.A	3												
42	87833-4219	N.A	N.A	1												
	87833-4220	N.A	N.A	2	YES	N.A	YES	YES	44.65	40.00	43.00	42.85	36.00	N.A	2.16	
	87833-4221	N.A	N.A	3												
44	87833-4419	N.A	N.A	1												
	87833-4420	N.A	N.A	2	YES	N.A	YES	YES	46.65	42.00	45.00	44.85	38.00	N.A	2.16	
	87833-4421	N.A	N.A	3												
	87833-4424	N.A	N.A	2	N.A	N.A	YES	YES								
	87832-4425	N.A	N.A	3												2.92
46	87833-4619	N.A	N.A	1												
	87833-4620	N.A	N.A	2	YES	N.A	YES	YES	48.65	44.00	47.00	46.85	40.00	N.A	2.16	
	87833-4621	N.A	N.A	3												
48	87833-4819	N.A	N.A	1												
	87833-4820	N.A	N.A	2	YES	N.A	YES	YES	50.65	46.00	49.00	48.85	42.00	N.A	2.16	
	87833-4821	N.A	N.A	3												
50	87833-5019	N.A	N.A	1												
	87833-5020	N.A	N.A	2	YES	N.A	YES	YES	52.65	48.00	51.00	50.85	44.00	N.A	0.15	
	87833-5021	N.A	N.A	3												

PLATING OPTIONS:

- 1 - 0.05-0.13um/2-5uin GOLD IN CONTACT AREA AND 1.88um/75uin MIN. MATTE TIN IN SOLDER TAIL AREA OVER 1.27um/50uin MIN. NICKEL OVERALL.
- 2 - 0.38um/15uin MIN. GOLD IN CONTACT AREA AND 1.88um/75uin MIN. MATTE TIN IN SOLDER TAIL AREA OVER 1.27um/50uin MIN. NICKEL OVERALL.
- 3 - 0.76um/30uin MIN. GOLD IN CONTACT AREA AND 1.88um/75uin MIN. MATTE TIN IN SOLDER TAIL AREA OVER 1.27um/50uin MIN. NICKEL OVERALL.

SEE SHEET 24.6.7 EC NO: S2016-0454 DRWN:GMENARLY 2015/11/05 CHKD:CGOH 2015/11/17 APPR:KHL IM 2015/11/18	DESCRIPTION QUALITY SYMBOLS $\nabla_A=0$ $\nabla_C=0$ $\nabla_P=0$	GENERAL TOLERANCES (UNLESS SPECIFIED)		DIMENSION STYLE MM ONLY		SCALE NTS	DESIGN UNITS METRIC	THIRD ANGLE PROJECTION		
			mm	INCH	DRAWN BY GMENARLY	DATE 2015/09/29	TITLE MILLIGRID 2MM PITCH, SMT R/A SHROUDED HEADER			
			4 PLACES ± --- ± ---	3 PLACES ± --- ± ---	CHECKED BY CGOH	DATE 2015/10/30	 DOCUMENT NO. SD-87833-0001 SHEET NO. 9 OF 9			
			2 PLACES ± 0.20 ± ---	1 PLACE ± --- ± ---	APPROVED BY KHL IM	DATE 2015/11/03				
A1	REV	DRAFT WHERE APPLICABLE MUST REMAIN WITHIN DIMENSIONS		ANGULAR ± 3 °	SEE TABLE	THIS DRAWING CONTAINS INFORMATION THAT IS PROPRIETARY TO MOLEX INCORPORATED AND SHOULD NOT BE USED WITHOUT WRITTEN PERMISSION				

## X-ON Electronics

Largest Supplier of Electrical and Electronic Components

*Click to view similar products for [Headers & Wire Housings](#) category:*

*Click to view products by [Molex](#) manufacturer:*

Other Similar products are found below :

[95000-104TRLF](#) [10135584-644402LF](#) [DF62W-EP2022PCA](#) [95000-106TRLF](#) [DF62W-2022SCA](#) [DF62W-EP2022PC](#) [2203348](#) [DF62W-2022SC](#) [1084018](#) [1029039](#) [1084017](#) [802-10-012-10-002000](#) [1112640](#) [1112639](#) [891-007-9SS-BST1T](#) [000-34000](#) [0008550134](#) [0009482033](#) [0009507031](#) [57102-F02-18ULF](#) [57102-S06-03LF](#) [57202-S52-04LF](#) [PCN6-15S-2.5E](#) [0039019024](#) [58102-G61-06LF](#) [582553-1](#) [0009485154](#) [0009508121](#) [0022285053](#) [0050291907](#) [018731A](#) [LY20-4P-DT1-P1E-BR](#) [02.125.8002.8](#) [60101931](#) [60598-1 \(Cut Strip\)](#) [M1625-3R/100](#) [61062-3](#) [61082-181009](#) [CSU011177004](#) [636-1427](#) [638009-1](#) [641938-9](#) [641991-4](#) [644168-1](#) [644827-2](#) [647662-1](#) [65039-019ELF](#) [65692-001LF](#) [65781-018](#) [65781-047](#)